

General Description

POWER ASSISTED SYSTEM (POWER STEERING)

1. General Description

A: SPECIFICATION

Model		Except for XV model	XV model
Whole system	Minimum turning radius	m (ft)	
	Steering angle	Inner wheel	38.3°±1.5°
		Outer wheel	33.7°±1.5°
	Steering wheel diameter	mm (in)	
Lock-to-lock revolution number	3.2	3.1	
Gearbox	Type	Rack & pinion type	
	Backlash	0 (Automatic adjusting)	
Motor (Temperature 20°C (68°F))	Rated voltage	V	
	Rated torque	N-m (kgf-m, ft-lb)	
	Rated revolution speed	rpm	
	Rated current	A	
	Rated output	W	

Model		Except for XV model	XV model	
Steering wheel	Free play	mm (in)		
Steering shaft	Clearance between the steering wheel and column cover	mm (in)		
Steering gearbox (Power steering system)	Sliding resistance	N (kgf, lbf)		
	Rack shaft play in the radial direction	Right-turn steering	mm (in)	
		Left-turn steering	mm (in)	
	Input shaft play	In radial direction	mm (in)	
		In axial direction	mm (in)	
	Rotational resistance	N (kgf, lbf)		
Steering wheel effort (Power steering system)	At standstill with engine idling on paved road	N (kgf, lbf)		
	At standstill with engine stalled on paved road	N (kgf, lbf)		

General Description

POWER ASSISTED SYSTEM (POWER STEERING)

B: COMPONENT

1. STEERING WHEEL AND COLUMN

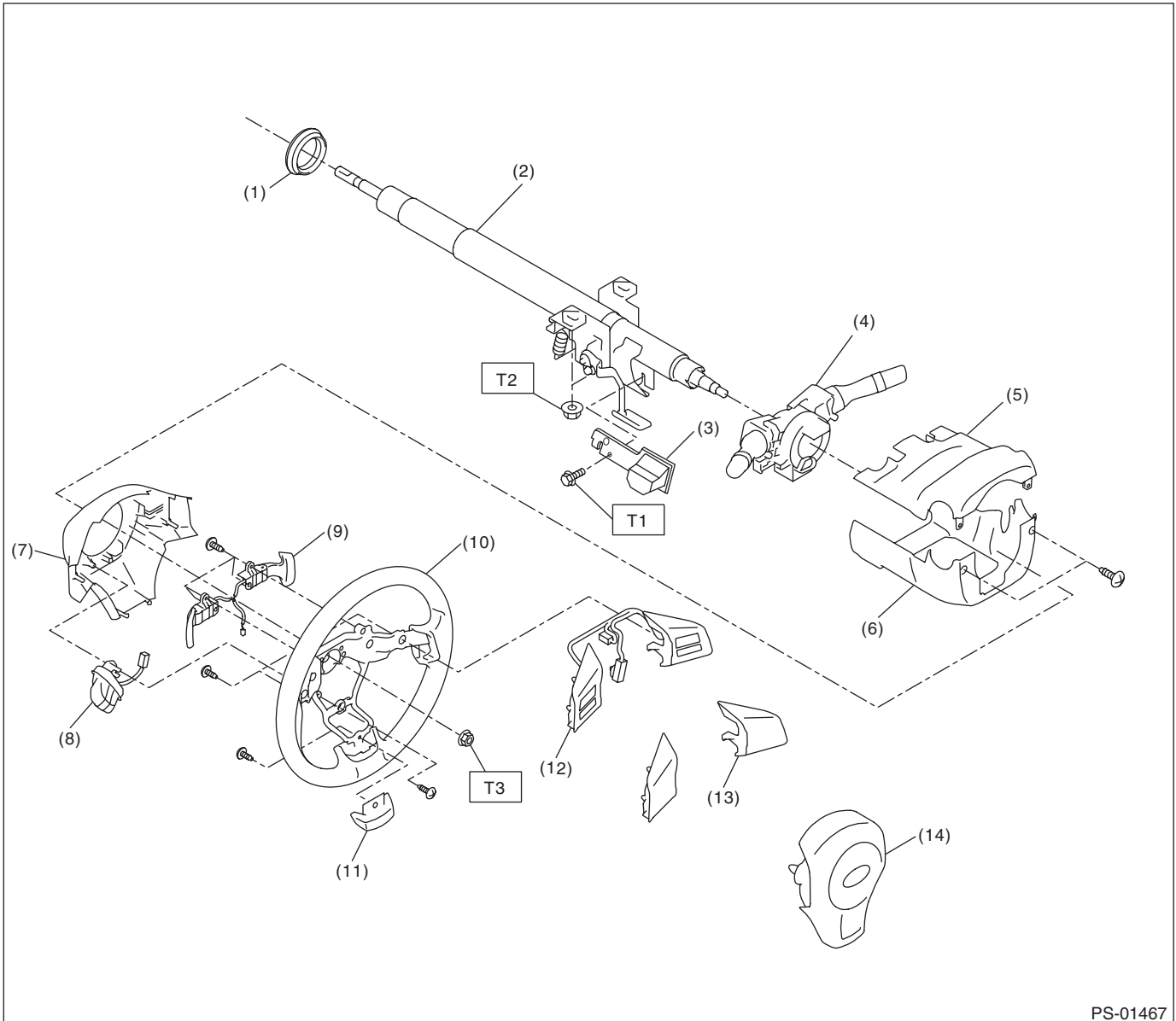

PS-01467

- | | |
|--------------------------------|----------------------|
| (1) Bushing | (8) Satellite switch |
| (2) Column ASSY - steering | (9) Paddle shift |
| (3) Dynamic damper | (10) Steering wheel |
| (4) Switch ASSY - combination | (11) Cover - spoke |
| (5) Cover ASSY - column UPR | (12) Switch |
| (6) Cover ASSY - column LWR | (13) Cover - switch |
| (7) Cover - steering wheel LWR | (14) Airbag module |

Tightening torque: N-m (kgf-m, ft-lb)

T1: 7.5 (0.76, 5.5)

T2: 20 (2.04, 14.8)

T3: 39 (3.98, 28.8)

General Description

POWER ASSISTED SYSTEM (POWER STEERING)

2. STEERING GEARBOX

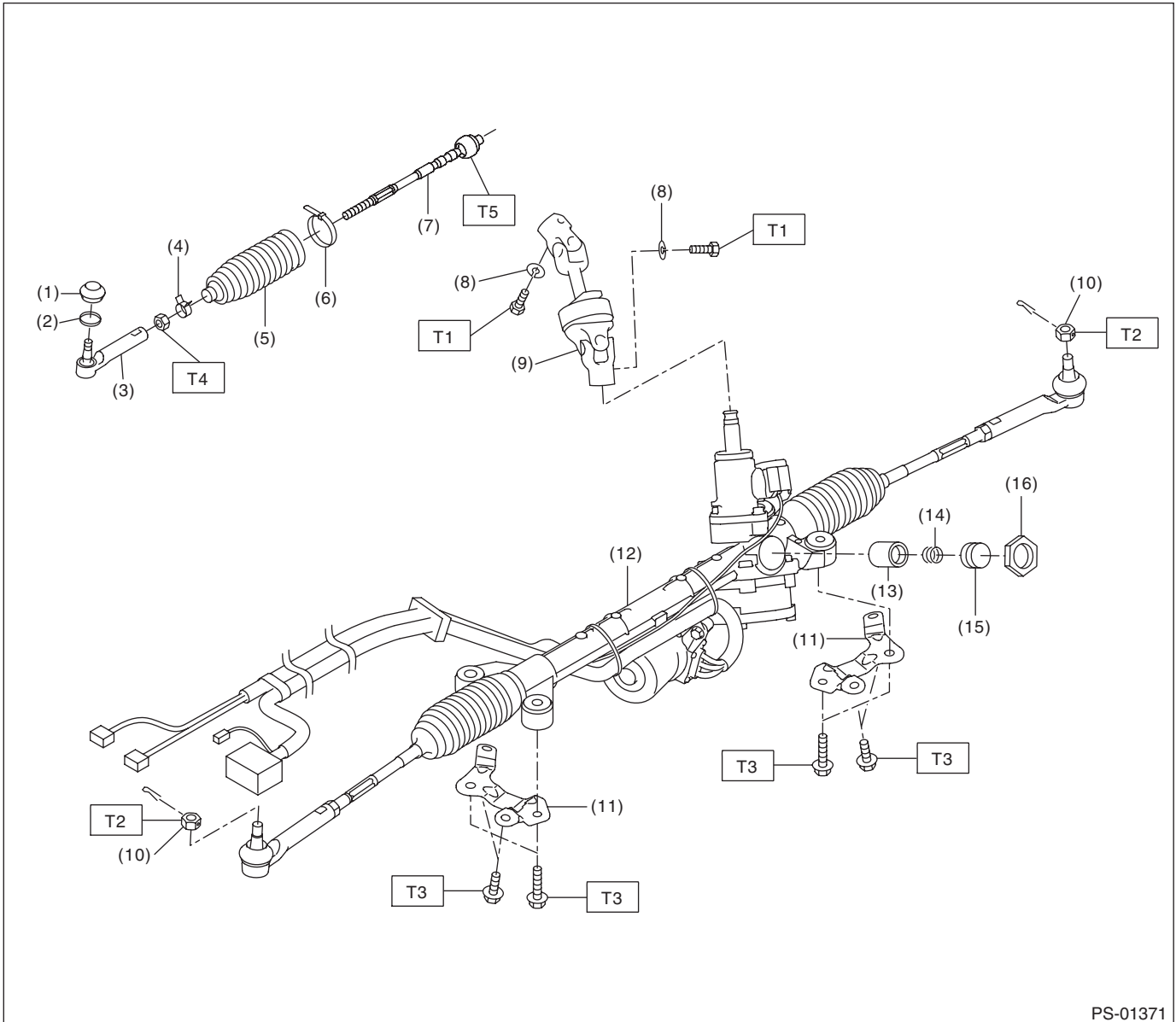

PS-01371

- | | |
|-------------------------------|-------------------------------------|
| (1) Dust seal | (9) Universal joint ASSY - steering |
| (2) Clip - boot tie-rod end B | (10) Castle nut |
| (3) Tie-rod end | (11) Stiffener |
| (4) Clip - boot tie-rod end A | (12) Steering gearbox ASSY |
| (5) Boot - steering gearbox | (13) Pad - pressure |
| (6) Band - boot | (14) Spring - gearbox |
| (7) Tie-rod | (15) Adjusting screw |
| (8) Spring washer | (16) Lock nut |

Tightening torque: N·m (kgf·m, ft·lb)

T1: 24 (2.45, 17.7)

T2: 27 (2.75, 19.9)

T3: 60 (6.12, 44.3)

T4: 85 (8.67, 62.7)

T5: 90 (9.18, 66.4)

General Description

POWER ASSISTED SYSTEM (POWER STEERING)

3. ELECTRIC POWER STEERING CONTROL MODULE

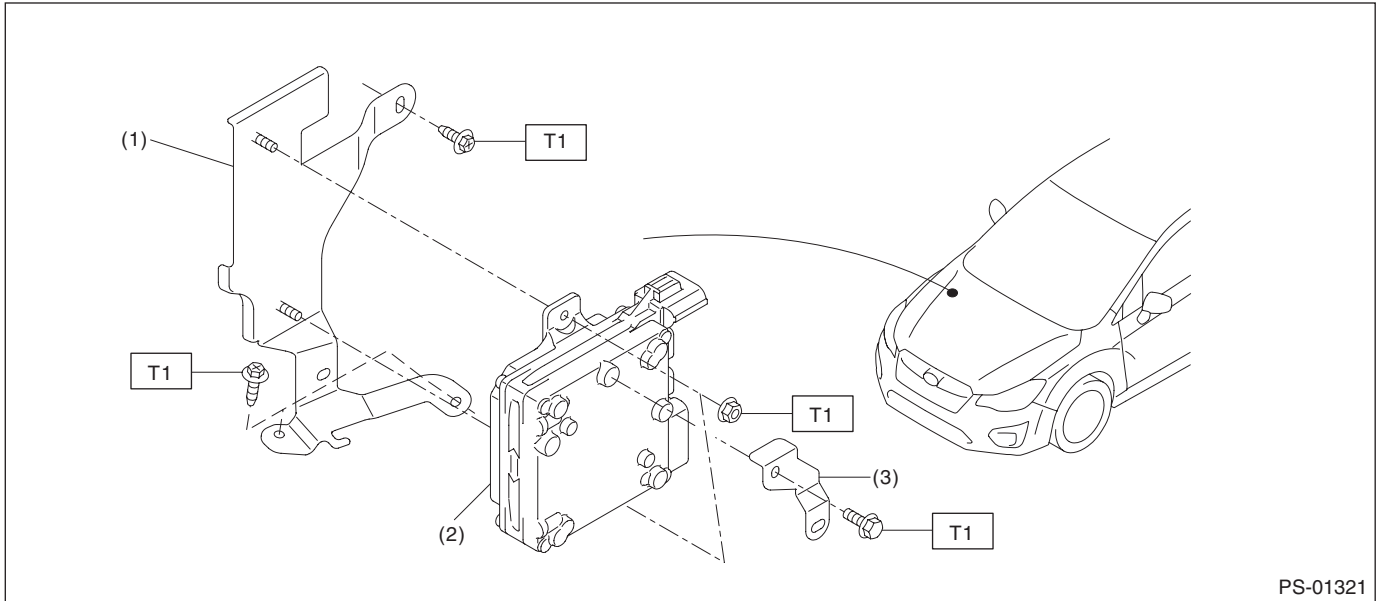

- (1) Bracket - control module
- (2) Power steering control module
- (3) Harness bracket

Tightening torque: N·m (kgf·m, ft·lb)
T: 7.5 (0.76, 5.5)

General Description

POWER ASSISTED SYSTEM (POWER STEERING)

C: CAUTION

- Wear appropriate work clothing, including a helmet, protective goggles and protective shoes when performing any work.
- Before removal, installation or disassembly, be sure to clarify the failure. Avoid unnecessary removal, installation, disassembly and replacement.
- Vehicle components are extremely hot after driving. Be wary of receiving burns from heated parts.
- Use grease and oil of Subaru genuine or the equivalent products. Do not mix them of different grades or manufacturers.
- Be sure to tighten fasteners including bolts and nuts to the specified torque.
- Place shop jacks or rigid racks at the specified points.
- Before securing a part on a vise, place cushioning material such as wooden blocks, aluminum plate or cloth between the part and the vise.

D: PREPARATION TOOL

1. SPECIAL TOOL

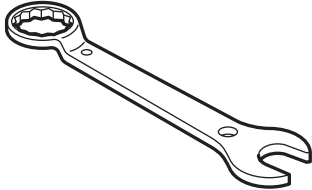
ILLUSTRATION	TOOL NUMBER	DESCRIPTION	REMARKS
 ST34099PA100	34099PA100	SPANNER	Used when measuring the rotating resistance of gearbox assembly.

2. GENERAL TOOL

TOOL NAME	REMARKS
Steering wheel puller	Used for removing the steering wheel.