

High-mounted Stop Light

LIGHTING SYSTEM

30.High-mounted Stop Light

A: REMOVAL

1. 4 DOOR MODEL

- 1) Disconnect the ground cable from battery.
- 2) Remove the light assembly - high-mounted.
 - (1) Disconnect the connector.

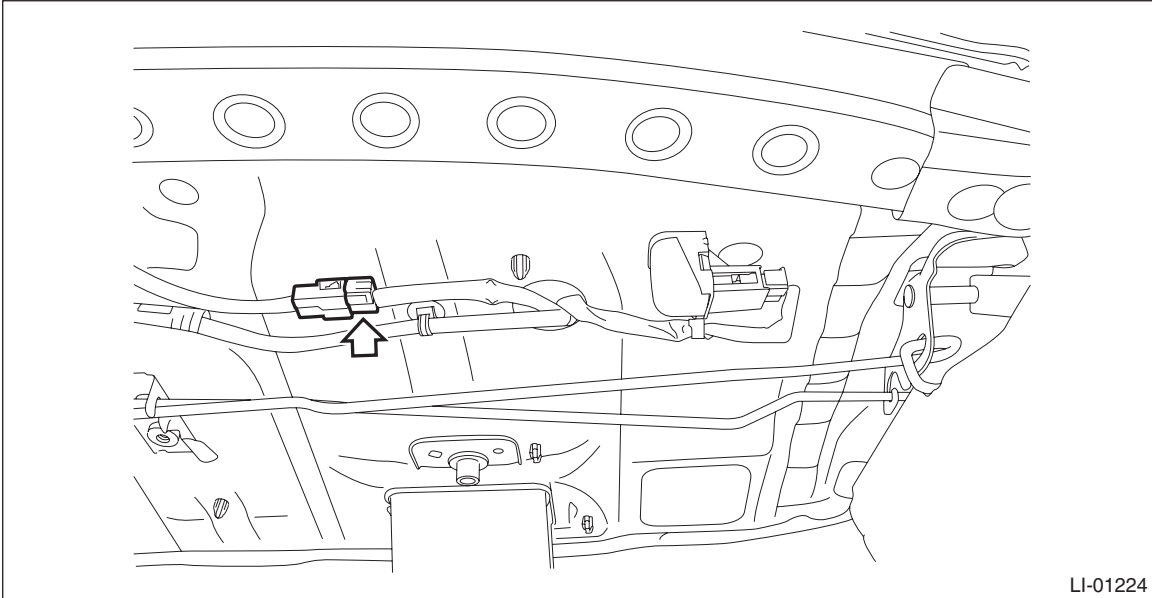

LI-01224

- (2) Release the claws, and remove the light assembly - high-mounted.

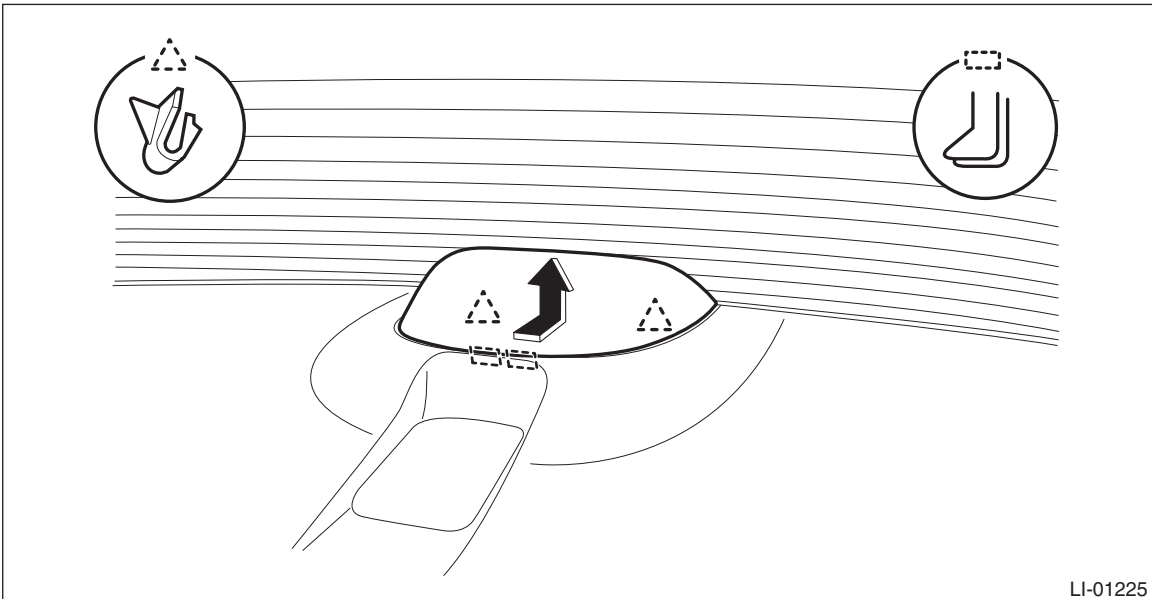

LI-01225

- (3) Release the claws and remove the reflector assembly from the light - case.

(4) Remove the lens and remove the bulb.

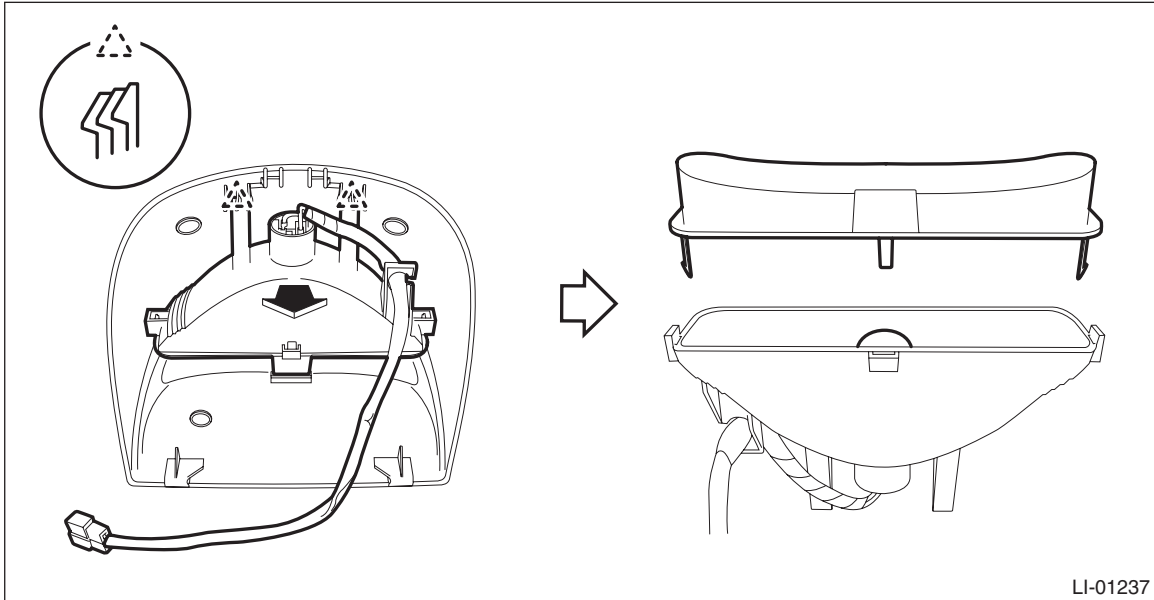

2. 5 DOOR MODEL/XV MODEL

- 1) Disconnect the ground cable from battery.
- 2) Remove the trim panel - rear gate UPR.
 - (1) Remove the claws on the trim edge.
 - (2) Release the claws in the center of trim, and remove the trim panel - rear gate UPR.

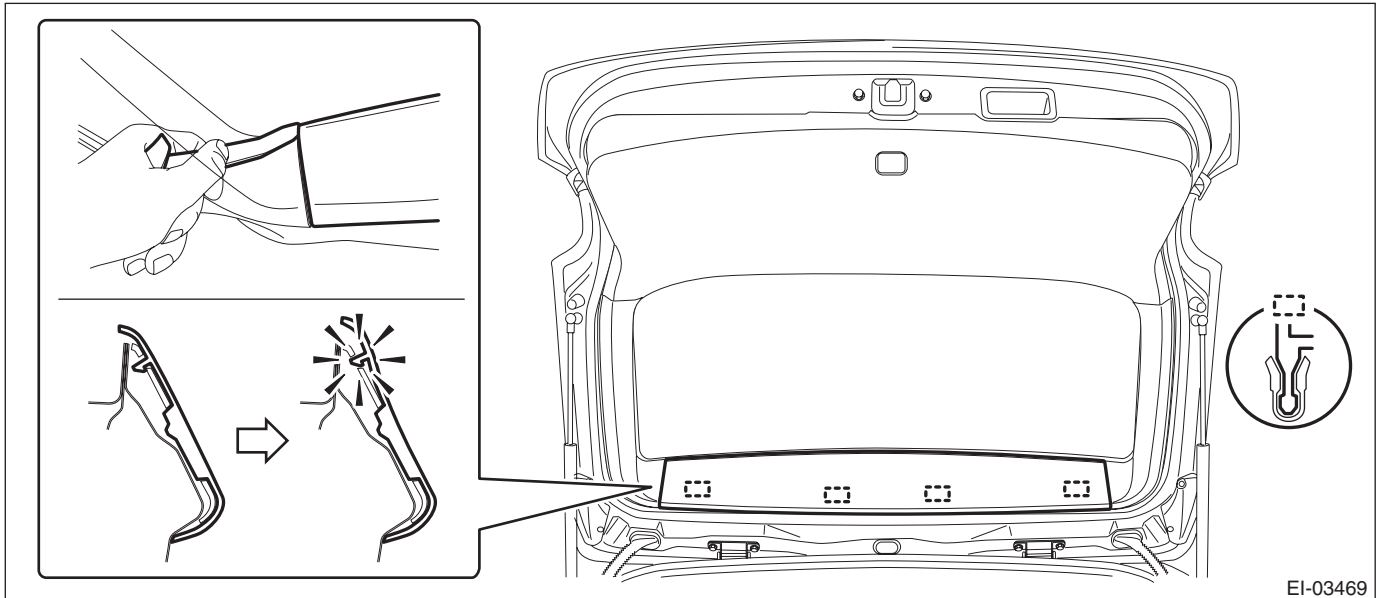

High-mounted Stop Light

LIGHTING SYSTEM

- 3) Remove the light assembly - high-mounted.
 - (1) Remove the nut.

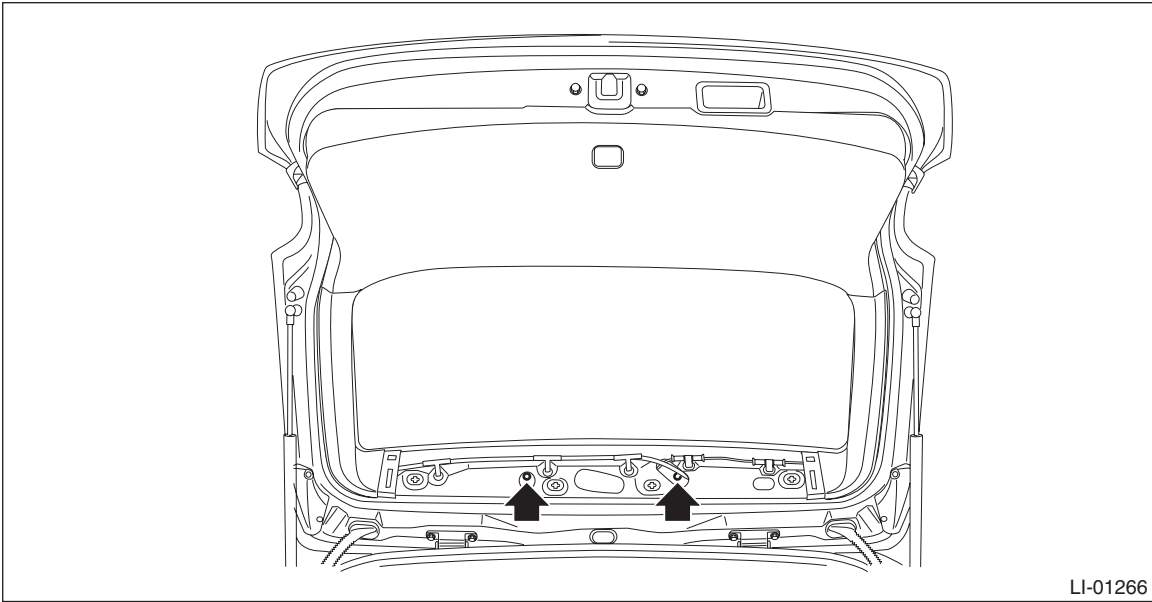

LI-01266

- (2) From the inside of the rear gate, push the claws on both side of the light assembly - high-mounted to take it out toward vehicle rear.
 - (3) Disconnect the connector and remove the light assembly - high-mounted.

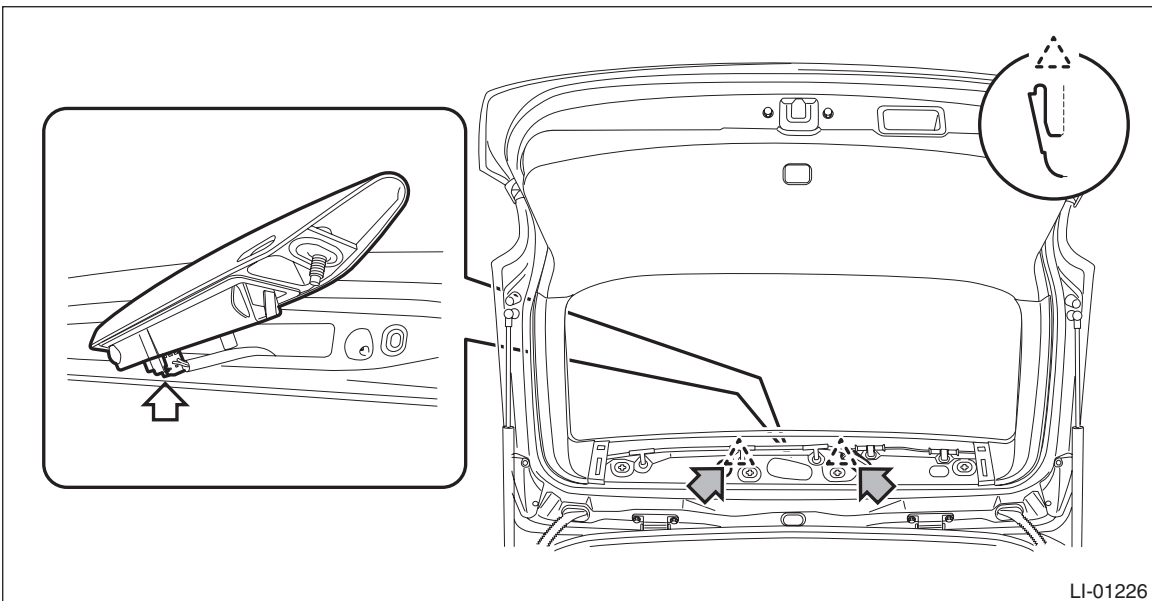

LI-01226

B: INSTALLATION

Install each part in the reverse order of removal.

Tightening torque:

Light assembly - high-mounted (5 door model/XV model): 4.5 N·m (0.46 kgf-m, 3.3 ft-lb)

C: INSPECTION

1. 4 DOOR MODEL

- 1) Visually check the bulb for blow out.
- 2) Check the bulb specification. <Ref. to LI-2, SPECIFICATION, General Description.>
- 3) Replace the bulb if it is found defective.

2. 5 DOOR MODEL/XV MODEL

- 1) Install the light to test if it illuminates normally.
- 2) If it fails to illuminate normally, replace the light assembly - high-mounted with a new part.

NOTE:

Since LED (Light Emitting Diode) is used for the light, replace the light assembly - high-mounted if the LED burns out.