

FOREWORD

FW

1. Foreword

FOREWORD

These manuals are used when performing maintenance, repair or diagnosis of SUBARU WRX and SUBARU WRX STI.

Applicable model: 2021 MY VAG**** and VAF****

The manuals contain the latest information at the time of publication. Changes in the specifications, methods, etc. may be made without notice.

HOW TO USE THIS MANUAL

HU

1. How to Use This Manual

HOW TO USE THIS MANUAL

1. STRUCTURE

Each section consists of SCT that are broken down into SC that are divided into sections for each component. The specification, maintenance and other information for the components are included, and the diagnostic information has also been added where necessary.

2. CONTENTS

The first page has an index with tabs.

3. COMPONENT

Illustrations are provided for each component. The information necessary for repair work (tightening torque, grease up points, etc.) is described on these illustrations. Information is described using symbol. To order parts, refer to parts catalogue.

Example:

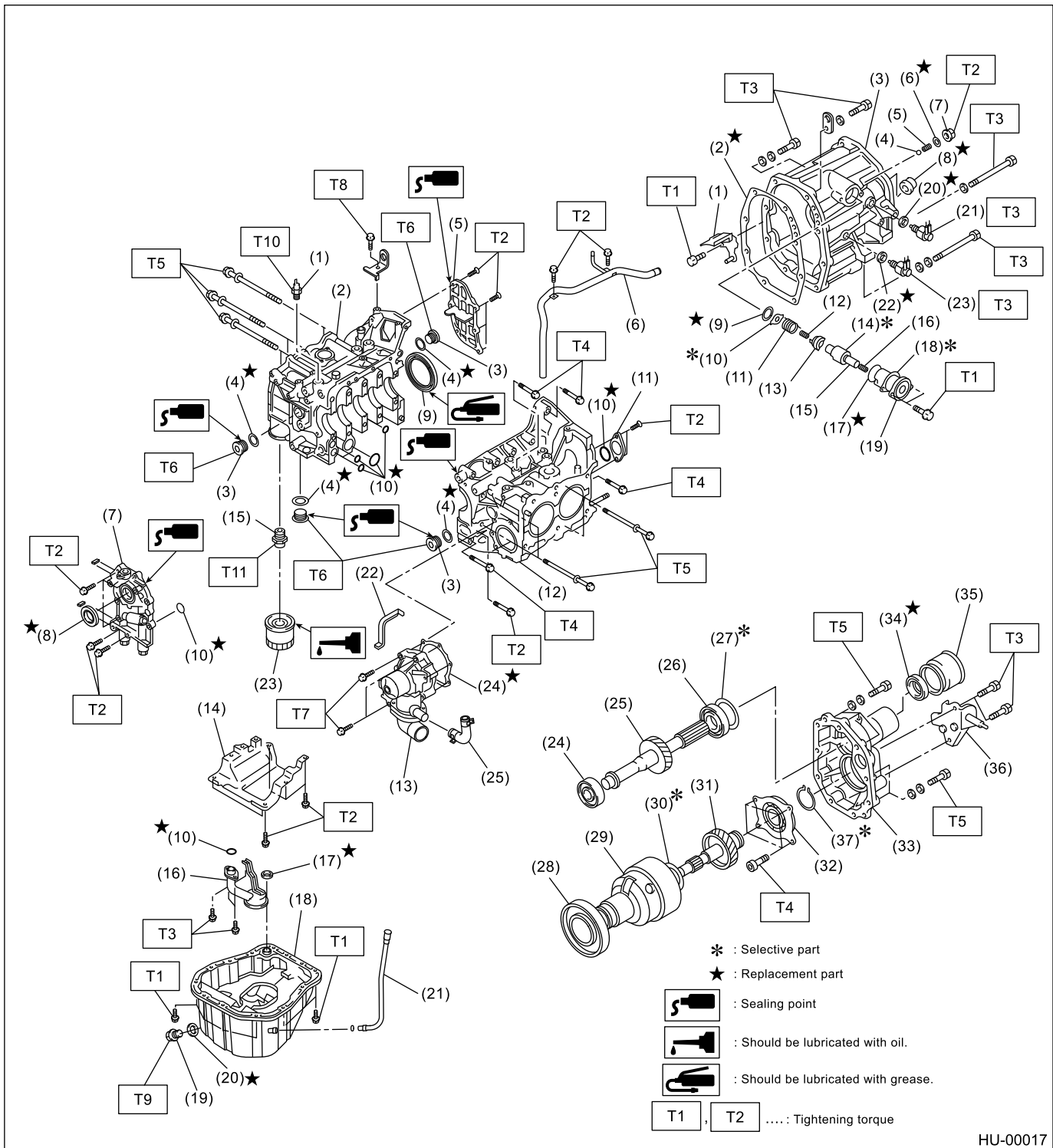

HU-00017

4. DEFINITIONS OF "NOTE", "CAUTION" AND "WARNING"

- **NOTE:**
Describes additional information to make works easier.
- **CAUTION:**
Describes prohibited matters to prevent vehicle or parts damage, or matters that requires special attention during work.
- **WARNING:**

Describes matters that may cause serious damage to the operator or other person, or that may cause damage or accident.

5. SPECIFICATIONS

If necessary, specifications are also included.

6. INSPECTION

Inspections to be carried out before and after maintenance are included.

7. MAINTENANCE

- Maintenance instructions for serviceable parts describe work area and detailed step with illustration. It also describes the use of special tool, tightening torque, caution for each procedure.
- If many serviceable parts are included in one service procedure, appropriate reference is provided for each part.

Example:

15.Main Shaft ← (A)

A: REMOVAL ← (B)

1) Remove the manual transmission assembly from vehicle. <Ref. to MT-33, REMOVAL, Manual Transmission Assembly.>

← (C)

11) Tighten the lock nuts to the specified torque using ST1 and ST2.

NOTE: ← (D)

Secure the lock nuts in two places after tightening.

ST1 498937000 TRANSMISSION HOLDER

ST2 499987003 (E) SOCKET WRENCH (35) (F)

Tightening torque:

118 N·m (12.0 kgf-m, 86.8 ft-lb) ← (G)

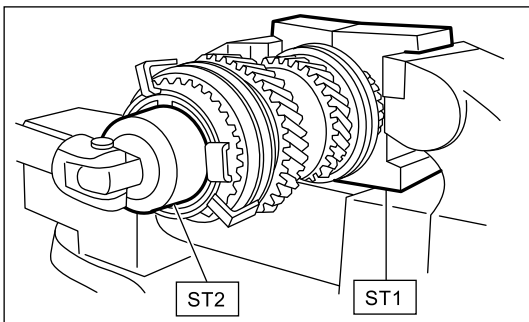

← (H)

- (A) Component (D) Cautions (G) Tightening torque
 (B) Process (E) Tool number of special tool (H) Illustration
 (C) Reference (F) Name of special tool

8. DIAGNOSIS

Step-by-step process is employed for easier diagnosis.

9. SI UNITS

Measurements in these manuals are according to the SI units. Metric and yard/pound measurements are also included.

Example:

Tightening torque:

44 N·m (4.5 kgf-m, 33 ft-lb)

List of SI unit

Item	SI units	Conventional unit	Remarks
Force	N (Newton)	kgf	1 kgf = 9.807 N
Mass (weight)	kg, g	kg, g	
Capacity	L, mL or cm ³	L or cc	1 cc = 1 cm ³ = 1 mL
Torque	N·m	kgf-m, kgf-cm	1 kgf-m = 9.807 N·m
Rotating speed	r/min	rpm	
Pressure	kPa (Kilopascal)	kgf/cm ²	1 kgf/cm ² = 98.07 kPa
		mmHg	1 mmHg = 0.1333 kPa
Power	W	PS	1 PS = 0.7355 kW
Calorie	W·h	cal	1 kcal = 1.163 W·h
Fuel consumption rate	g/kW·h	g/PS·h	1 g/PS·h = 1.3596 g/kW·h

The figure used in these manuals are described in the SI units and conventional units are described in ().

10. EXPLANATION OF TERMINOLOGY

List

2ndr	Secondary
AAI	Air Assist Injection
AAR	Angular Adjusted Roller
A/B	Airbag
ABS	Anti-lock Brake System
A/C	Air Conditioner
AC	Angular Contact
ACC	Accessory
A/F	Air Fuel Ratio
ALT	Generator

API	American Petroleum Institute
APS	Accessory Power Supply Socket
ASSY	Assembly
AT	Automatic Transmission
ATF	Automatic Transmission Fluid
AUX	Auxiliary Storage Unit (External storage)
AVCS	Active Valve Control System
AVH	Auto Vehicle Hold
AWD	All Wheel Drive
BATT	Battery
BCM	Brake Control Module
BECM	Battery Energy Control Module
BJ	Bell Joint
BRKT	Bracket
BSD/RCTA	Blind Spot Detection / Rear Cross Traffic Alert
CAN	Controller Area Network
CCA	Cold Cranking Ampere
CD	Compact Disc
CD-R/RW	CD Recordable/Rewritable
COMPL	Complete
CPC	Canister Purge Control Solenoid Valve
CPU	Central Processing Unit
CTR	Center
CM	Control Module
CVT	Continuously Variable Transmission
CVTF	Continuously Variable Transmission Fluid
CWP	Cold Weather Package
DCCD	Driver's Control Center Differential
DMCM	Drive Motor Control Module
DOHC	Double Overhead Camshaft
DOJ	Double Offset Joint
D/R	Dual-range
DTC	Diagnosis Trouble Code
DU	Drive Unit
DVD	Digital Versatile Disc or Digital Video Disc
EBD	Electronic Brake Distribution
EBJ	High-Efficiency Compact Ball Fixed Joint
ECM	Engine Control Module
ECV	Exhaust Pressure Control Valve
EDJ	High-Efficiency Compact Double Offset Joint

E/G	Engine
EGI	Electronic Gasoline Injection
EGR	Exhaust Gas Recirculation
ELR	Emergency Locking Retractor
EPB	Electronic Parking Brake
ETC	Electronic Throttle Control
EX	Exhaust
F/B	Fuse & Joint Box
FL	Fusible Link
Ft	Front
FWD	Front Wheel Drive
GPS	Global Positioning System
HBA	High Beam Assist
HI	High
HID	High-Intensity Discharge
H/K	Harman/Kardon Audio
HPCM	Hybrid Powertrain Control Module
H/L	Headlight
H/U	Hydraulic Unit
HVAC	Heater, Ventilator and Air Conditioner
I/F	Interface
IG	Ignition
ILSAC	International Lubricants Standardization and Approval Committee
IN	Intake
INT	Intermittent
I/O	Input/Output
IR	Infrared Ray
ISC	Idle Speed Control
ISG	Integrated Starter Generator
K/A	Keyless Access
LAN	Local Area Network
LCD	Liquid Crystal Display
LED	Light Emitting Diode
LH	LH (Left Hand)
LHD	Left Hand Drive
Lo	Low
LSD	Limited Slip Differential
LWR	Lower
M/B	Main Fuse & Relay Box
MD	Mini Disc

MID	Multi Information Display
MFI	Multi-Point Fuel Injection
MP-T	Multi-Plate Transfer
M/R	Moon Roof
MT	Manual Transmission
NA	Natural Aspiration
NC	Normal Close (Relay)
NO	Normal Open (Relay)
OBD	On-Board Diagnosis
OP	Option Parts
PC	Personal Computer
PCD	Pitch Circle Diameter
PCV	Positive Crankcase Ventilation
PID	Parameter Identification
Pr	Primary
PRG	Power Rear Gate
P/S	Power Steering
PTJ	Pillow Tripod Joint
P/W	Power Window
RAB	Reverse Automatic Braking
RAM	Random Access Memory
RH	RH (Right Hand)
RHD	Right Hand Drive
ROM	Read Only Memory
Rr	Rear
SDI	Subaru Diagnostic Interface
SI	Subaru Intelligent
SOHC	Single Overhead Camshaft
SRH	Steering Responsive Headlight
SRS	Supplemental Restraint System
SSM	Subaru Select Monitor
ST	Special Tool
STD	Standard
SW	Switch
T/B	Turbocharger
TCS	Traction Control System
TCM	Transmission Control Module
TGV	Tumble Generator Valve
T/M	Transmission
TPMS	Tire Pressure Monitoring System

UJ	Universal Joint
UPR	Upper
UV	Ultraviolet
VDC	Vehicle Dynamics Control
V.I.N.	Vehicle Identification Number
ViS-C	Viscous Coupling
VSV	Vacuum Switching Valve
VTD	Variable Torque Distribution
W/H	Wiring Harness

SPECIFICATIONS

SPC

-
1. WRX
 2. WRX STI

SPECIFICATIONS > WRX

DIMENSION

Model		2.0 L DOHC turbo	
Overall length	mm (in)	4,595 (180.9)	
Overall width	mm (in)	1,795 (70.7)	
Overall height	mm (in)	1,475 (58.1)	
Compartment	Length	mm (in)	2,005 (78.9)
	Width	mm (in)	1,490 (58.7)
	Height	mm (in)	1,205 (47.4), 1,180 (46.5)*
Wheelbase		mm (in)	2,650 (104.3)
Tread	Front	mm (in)	1,530 (60.2)
	Rear	mm (in)	1,540 (60.6)
Minimum road clearance		mm (in)	125 (4.9)

*: With sunroof

SPECIFICATIONS > WRX

ENGINE

Model		2.0 L DOHC turbo	
Engine type		Horizontally opposed, liquid cooled, 4-cylinder, 4-stroke gasoline engine	
Valve arrangement		DOHC	
Bore × stroke	mm (in)	86.0 × 86.0 (3.39 × 3.39)	
Displacement	cm ³ (cu in)	1,998 (122)	
Compression ratio		10.6	
Ignition order		1 – 3 – 2 – 4	
Idle speed at parking or neutral position	r/min	700±100	
Maximum output	kW (HP)/(r/min)	200 (268)/5,600	

Maximum torque	N·m (kgf-m, ft-lb)/(r/min)	350 (35.7, 258)/2,000 – 5,200
----------------	----------------------------	-------------------------------

SPECIFICATIONS > WRX

ELECTRICAL

Model		2.0 L DOHC turbo	
		CVT	6MT
Ignition timing (at idling)	BTDC	8°±10°	6°±10°
Spark plug	Type and manufacturer	NGK: ILKAR8H6	
Generator		12 V – 130 A	
Battery	Type	75D23L	
	Nominal capacity	5 HR: 53 Ah [25°C (77°F)]	
	Nominal voltage	12 V	
	CCA	470 A	
	BCI group number*	35	

*: This is a reference information for battery size, and is not guaranteed by SUBARU CORPORATION.

SPECIFICATIONS > WRX

TRANSMISSION

1. MT

Model		2.0 L DOHC turbo	
Transmission type		6MT	
Clutch type		DSPD	
Gear ratio	1st	3.455	
	2nd	1.947	
	3rd	1.296	
	4th	0.972	
	5th	0.780	
	6th	0.667	
	Rev.	3.636	
Reduction gear (front)	Type of gear	Hypoid	
	Gear ratio	4.111	
Transfer reduction	Type of gear	Helical	
	Gear ratio	1.000	
Reduction gear (rear)	Type of gear	Hypoid	

	Gear ratio	4.111
--	------------	-------

6MT: 6-forward speeds and 1-reverse with synchromesh

DSPD: Dry Single Plate Diaphragm

2. CVT

Model		2.0 L DOHC turbo
Transmission type		CVT
Clutch type		TCC
Gear ratio (including transfer reduction ratio)	Forward	3.508 — 0.545
	Rev.	2.350
Reduction gear (front)	Type of gear	Hypoid
	Gear ratio	3.900
Transfer reduction ratio		1.000
Reduction gear (rear)	Type of gear	Hypoid
	Gear ratio	3.900

CVT: Forward continuously variable speed change, 1-reverse

TCC: Torque Converter Clutch

SPECIFICATIONS > WRX

STEERING

Model		2.0 L DOHC turbo	
Type		Rack and pinion	
		Electric power steering	
Turns, lock to lock		2.8* ¹	2.7* ²
Minimum turning radius	m (ft)	5.4 (17.72)* ¹	5.5 (18.05)* ²

*1: When 235/45R17 are attached

*2: When 245/40R18 are attached

SPECIFICATIONS > WRX

SUSPENSION

Model		2.0 L DOHC turbo
Front		Macpherson strut type suspension
Rear		Double-wishbone type suspension

SPECIFICATIONS > WRX

BRAKE

Model	2.0 L DOHC turbo
-------	------------------

Service brake system	Dual circuit hydraulic with vacuum suspended power unit	
Front	Ventilated disc brake	
Rear	Solid disc brake	Ventilated disc brake
Parking brake	Mechanical on rear brakes	Electrical on rear brakes

SPECIFICATIONS > WRX

TIRE

Model	2.0 L DOHC turbo	
Wheel size	17 × 8 J	18 × 8 1/2 J
Tire size	235/45R17 94W	245/40R18 97W
Type	Tubeless, steel belted radial	

SPECIFICATIONS > WRX

CAPACITY

Model		2.0 L DOHC turbo		
		CVT	6MT	
Fuel tank	L (US gal, Imp gal)	60 (15.9, 13.2)		
Engine oil	Total capacity (at overhaul)		6.0 (6.3, 5.3)	
	L (US qt, Imp qt)			
	Filling amount of engine oil	When replacing engine oil and oil filter	5.1 (5.4, 4.5)	
	L (US qt, Imp qt)	When replacing engine oil only	4.9 (5.2, 4.3)	
Transmission gear oil	L (US qt, Imp qt)	—	3.3 (3.5, 2.9)	
CVTF	L (US qt, Imp qt)	12.11 — 12.61 (12.8 — 13.3, 10.7 — 11.1)	—	
CVT front differential gear oil	L (US qt, Imp qt)	1.3 — 1.5 (1.4 — 1.6, 1.1 — 1.3)	—	
Rear differential gear oil	L (US qt, Imp qt)	0.8 (0.8, 0.7)		
Engine coolant	L (US qt, Imp qt)	8.3 (8.8, 7.3)	8.1 (8.6, 7.2)	

SPECIFICATIONS > WRX

WEIGHT

Model		Sedan							
		2.0 L DOHC turbo							
		WRX base	WRX base+L		WRX Pre+L				
		6MT	6MT	CVT	6MT			CVT	
OP code		C0	U4	U4	U4	U4	C0	U4	
		KC	XC	XC	KG	WK	LD	KG	
Curb weight (C.W.)	Total	k g (l b)	1,49 5 (3,29 6)	1,49 4 (3,29 4)	1,55 3 (3,42 4)	1,52 0 (3,35 1)	1,51 5 (3,34 0)	1,51 9 (3,34 9)	1,579 (3,48 2)
	Front	k g (l b)	895 (1,97 3)	893 (1,96 9)	945 (2,08 3)	904 (1,99 3)	903 (1,99 1)	905 (1,99 5)	956 (2,10 8)
	Rear	k g (l b)	600 (1,32 3)	601 (1,32 5)	608 (1,34 1)	616 (1,36 0)	612 (1,34 9)	614 (1,35 4)	623 (1,37 4)
Gross vehicle weight (G.V.W.)		k g (l b)	2,00 0 (4,40 9)	2,00 0 (4,40 9)	2,00 0 (4,40 9)	2,00 0 (4,40 9)	2,00 0 (4,40 9)	2,00 0 (4,40 9)	2,000 (4,40 9)
Maximum permissible axle weight (G.A.W.)	Front	k g (l b)	1,07 5 (2,37 0)	1,07 5 (2,37 0)	1,07 5 (2,37 0)	1,07 5 (2,37 0)	1,07 5 (2,37 0)	1,07 5 (2,37 0)	1,075 (2,37 0)
	Rear	k g (l b)	1,04 0 (2,29 3)	1,04 0 (2,29 3)	1,04 0 (2,29 3)	1,04 0 (2,29 3)	1,04 0 (2,29 3)	1,04 0 (2,29 3)	1,040 (2,29 3)
Option	Genuine leather seat		—	—	—	—	—	—	—
	RECARO seat		—	—	—	—	○	—	—
	Cold weather package		○	—	—	○	○	○	○
	Safety view package		—	—	—	—	—	—	—

Advanced package	—	—	—	—	—	○	—
Performance damper	—	—	—	—	○	—	—
BASE AUDIO	○	○	○	—	—	○	—
HIGH AUDIO	—	—	—	○	○	—	○
NAVI	—	—	—	—	—	—	—
Harman/Kardon speaker system	—	—	—	—	—	—	—
Sunroof	—	—	—	○	—	○	○
High performance brake package	—	—	—	—	—	—	—

Model		Sedan						
		2.0 L DOHC turbo						
		WRX Ltd+L						
		6MT						
OP code		U4	U4	U4	U4	C0	C4	
		UG	ME	NF	MF	NJ	OF	
Curb weight (C.W.)	Total	k g (l b)	1,52 9 (3,37 1)	1,54 6 (3,40 9)	1,54 3 (3,40 2)	1,54 6 (3,40 9)	1,54 4 (3,40 5)	1,550 (3,41 7)
	Front	k g (l b)	910 (2,00 6)	915 (2,01 8)	914 (2,01 5)	915 (2,01 8)	911 (2,00 9)	912 (2,01 1)
	Rear	k g (l b)	619 (1,36 5)	631 (1,39 1)	629 (1,38 7)	631 (1,39 1)	633 (1,39 6)	638 (1,40 6)
Gross vehicle weight (G.V.W.)		k g (l b)	2,00 (4,40 9)	2,00 (4,40 9)	2,00 (4,40 9)	2,00 (4,40 9)	2,00 (4,40 9)	2,000 (4,40 9)
Maximum permissible axle weight (G.A.W.)	Front	k g (l b)	1,07 5 (2,37 0)	1,07 5 (2,37 0)	1,07 5 (2,37 0)	1,07 5 (2,37 0)	1,07 5 (2,37 0)	1,075 (2,37 0)
	Rear	k g (l b)	1,04 0 (2,29 3)	1,04 0 (2,29 3)	1,04 0 (2,29 3)	1,04 0 (2,29 3)	1,04 0 (2,29 3)	1,040 (2,29 3)
Option	Genuine leather seat		○	—	○	—	○	○
	RECARO seat		—	○	—	○	—	—
	Cold weather package		○	○	○	○	○	—
	Safety view package		—	—	—	—	—	○
	Advanced package		—	○	○	○	○	○
	Performance damper		—	—	—	—	—	—

BASE AUDIO	—	—	—	—	—	—
HIGH AUDIO	○	○	—	—	—	—
NAVI	—	—	○	○	○	○
Harman/Kardon speaker system	—	○	○	○	○	○
Sunroof	○	○	○	○	○	○
High performance brake package	—	—	—	—	○	—

Model		Sedan				
		2.0 L DOHC turbo				
		WRX Ltd+L		WRX ES Pre+L		
		CVT				
OP code		U4	C4	U4	C0	
		NE	OF	KG	LD	
Curb weight (C.W.)	Total	k g (l b)	1602 9 (3,53 2)	1,60 9 (3,54 7)	1,58 4 (3,49 2)	1,58 4 (3,49 2)
	Front	k g (l b)	966 (2,13 0)	964 (2,12 5)	959 (2,11 4)	961 (2,11 9)
	Rear	k g (l b)	636 (1,40 2)	645 (1,42 2)	625 (1,37 8)	623 (1,37 3)
Gross vehicle weight (G.V.W.)		k g (l b)	2,00 0 (4,40 9)	2,00 0 (4,40 9)	2,00 0 (4,40 9)	2,00 0 (4,40 9)
Maximum permissible axle weight (G.A.W.)	Front	k g (l b)	1,07 5 (2,37 0)	1,07 5 (2,37 0)	1,07 5 (2,37 0)	1,07 5 (2,37 0)
	Rear	k g (l b)	1,04 0 (2,29 3)	1,04 0 (2,29 3)	1,04 0 (2,29 3)	1,04 0 (2,29 3)
Option	Genuine leather seat		○	○	—	—
	RECARO seat		—	—	—	—
	Cold weather package		○	—	○	○
	Safety view package		—	○	—	—
	Advanced package		○	○	—	○

Performanc e damper	—	—	—	—
BASE AUDIO	—	—	—	○
HIGH AUDIO	○	—	○	—
NAVI	—	○	—	—
Harman/Kar don speaker system	○	○	—	—
Sunroof	○	○	○	○
High performanc e brake package	—	—	—	—

Model		Sedan				
		2.0 L DOHC turbo				
		WRX ES Ltd+L				
		CVT				
OP code		U4	U4	C0	C4	
		UG	NF	NF	OF	
Curb weight (C.W.)	Total	k g (l b)	1,59 3 (3,51 2)	1,60 8 (3,54 5)	1,60 8 (3,54 5)	1,61 4 (3,55 8)
	Front	k g (l b)	965 (2,12 7)	969 (2,13 6)	969 (2,13 6)	967 (2,13 2)
	Rear	k g (l b)	628 (1,38 5)	639 (1,40 9)	639 (1,40 9)	647 (1,42 6)
Gross vehicle weight (G.V.W.)		k g (l b)	2,00 0 (4,40 9)	2,00 0 (4,40 9)	2,00 0 (4,40 9)	2,00 0 (4,40 9)
Maximum permissible axle weight (G.A.W.)	Front	k g (l b)	1,07 5 (2,37 0)	1,07 5 (2,37 0)	1,07 5 (2,37 0)	1,07 5 (2,37 0)
	Rear	k g (l b)	1,04 0 (2,29 3)	1,04 0 (2,29 3)	1,04 0 (2,29 3)	1,04 0 (2,29 3)
Option	Genuine leather seat		○	○	○	○
	RECARO seat		—	—	—	—
	Cold weather package		○	○	○	—
	Safety view package		—	—	—	○
	Advanced package		—	○	○	○
	Performance damper		—	—	—	—

BASE AUDIO	—	—	—	—
HIGH AUDIO	○	—	—	—
NAVI	—	○	○	○
Harman/Kardon speaker system	—	○	○	○
Sunroof	○	○	○	○
High performance brake package	—	—	—	—

SPECIFICATIONS > WRX STI

DIMENSION

Model		2.5 L DOHC high power turbo	
Overall length	mm (in)	4,595 (180.9)	
Overall width	mm (in)	1,795 (70.7)	
Overall height	mm (in)	1,475 (58.1)	
Compartment	Length	mm (in)	2,005 (78.9)
	Width	mm (in)	1,490 (58.7)
	Height	mm (in)	1,205 (47.4), 1,180 (46.5)*
Wheelbase	mm (in)	2,650 (104.3)	
Tread	Front	mm (in)	1,530 (60.2)
	Rear	mm (in)	1,540 (60.6)
Minimum road clearance	mm (in)	125 (4.9)	

*: With sunroof

SPECIFICATIONS > WRX STI

ENGINE

Model		2.5 L DOHC high power turbo	
Engine type		Horizontally opposed, liquid cooled, 4-cylinder, 4-stroke gasoline engine	
Valve arrangement		DOHC	
Bore × stroke	mm (in)	99.5 × 79.0 (3.92 × 3.11)	
Displacement	cm ³ (cu in)	2,457 (150)	
Compression ratio		8.2	
Ignition order		1 – 3 – 2 – 4	
Idle speed at parking or neutral position	r/min	700±100	
Maximum output	kW (HP)/(r/min)	231 (310)/6,000	

Maximum torque	N·m (kgf-m, ft-lb)/(r/min)	393 (40.2, 290)/4,000 — 5,200
----------------	----------------------------	-------------------------------

SPECIFICATIONS > WRX STI

ELECTRICAL

Model		2.5 L DOHC high power turbo
Ignition timing (at idling)	BTDC	15°±10°
Spark plug	Type and manufacturer	NGK: ILFR7H
Generator		12 V — 110 A
Battery	Type	75D23L
	Nominal capacity	5 HR: 53 Ah [25°C (77°F)]
	Nominal voltage	12 V
	CCA	470 A
	BCI group number*	35

*: This is a reference information for battery size, and is not guaranteed by SUBARU CORPORATION.

SPECIFICATIONS > WRX STI

TRANSMISSION

1. MT

Model		2.5 L DOHC high power turbo
Transmission type		6MT
Clutch type		DSPD
Gear ratio	1st	3.636
	2nd	2.235
	3rd	1,591
	4th	1.138
	5th	0.971
	6th	0.756
	Rev.	3.545
Reduction gear (front)	Type of gear	Hypoid
	Gear ratio	3.900
Transfer reduction	Type of gear	Helical
	Gear ratio	1.103
Reduction gear (rear)	Type of gear	Hypoid
	Gear ratio	3.545

6MT: 6-forward speeds and 1-reverse with synchromesh

DSPD: Dry Single Plate Diaphragm

SPECIFICATIONS > WRX STI

STEERING

Model	2.5 L DOHC high power turbo	
Type	Rack and pinion	
	Hydraulic power steering	
Turns, lock to lock	2.5	
Minimum turning radius	m (ft)	5.5 (18.05)

SPECIFICATIONS > WRX STI

SUSPENSION

Model	2.5 L DOHC high power turbo	
Front	Macpherson strut type suspension	
Rear	Double-wishbone type suspension	

SPECIFICATIONS > WRX STI

BRAKE

Model	2.5 L DOHC high power turbo	
Service brake system	Dual circuit hydraulic with vacuum suspended power unit	
Front	Ventilated disc brake	
Rear	Ventilated disc brake	
Parking brake	Mechanical on rear brakes	

SPECIFICATIONS > WRX STI

TIRE

Model	2.5 L DOHC high power turbo	
Wheel size	18 × 8 1/2J	19 × 8 1/2J
Tire size	245/40R18 97W	245/35R19 89W
Type	Tubeless, steel belted radial	

SPECIFICATIONS > WRX STI

CAPACITY

Model	2.5 L DOHC high power turbo	
Fuel tank	L (US gal, Imp gal)	60 (15.9, 13.2)

Engine oil	Total capacity (at overhaul)		5.0 (5.3, 4.4)
	L (US qt, Imp qt)		
	Filling amount of engine oil	When replacing engine oil and oil filter	4.3 (4.5, 3.8)
	L (US qt, Imp qt)	When replacing engine oil only	4.0 (4.2, 3.5)
Transmission gear oil	L (US qt, Imp qt)		4.1 (4.3, 3.6)
Rear differential gear oil	L (US qt, Imp qt)		1.0 (1.1, 0.9)
Power steering fluid	L (US qt, Imp qt)		0.7 (0.7, 0.6)
Engine coolant	L (US qt, Imp qt)		7.7 (8.2, 6.8)

SPECIFICATIONS > WRX STI

WEIGHT

Model		Sedan				
		2.5 L DOHC high power turbo				
		STI base	STI base +W	STI Pfm+W		
		6MT				
OP code		C0	U4	U4	U4	
		KC	KK	YK	WK	
Curb weight (C.W.)	Total	k g (l b)	1,55 1 (3,41 9)	1,56 5 (3,45 0)	1,57 1 (3,46 3)	1,57 1 (3,46 3)
	Front	k g (l b)	920 (2,02 8)	921 (2,03 0)	924 (2,03 7)	924 (2,03 7)
	Rear	k g (l b)	631 (1,39 1)	644 (1,42 0)	647 (1,42 6)	647 (1,42 6)
Gross vehicle weight (G.V.W.)		k g (l b)	2,00 0 (4,40 9)	2,00 0 (4,40 9)	2,00 0 (4,40 9)	2,00 0 (4,40 9)
Maximum permissible axle weight (G.A.W.)	Front	k g (l b)	1,07 5 (2,37 0)	1,07 5 (2,37 0)	1,07 5 (2,37 0)	1,07 5 (2,37 0)
	Rear	k g (l b)	1,04 0 (2,29 3)	1,04 0 (2,29 3)	1,04 0 (2,29 3)	1,04 0 (2,29 3)
Option	Genuine leather seat		—	—	—	—
	RECARO seat		—	—	○	○
	Cold weather package		○	○	○	○

Safety view package	—	—	—	—
Advanced package	—	—	—	—
Performance damper	—	—	—	○
BASE AUDIO	○	—	—	—
HIGH AUDIO	—	○	○	○
NAVI	—	—	—	—
Harman/Kardon speaker system	—	—	—	—
Sunroof	—	—	—	—
High performance brake package	—	—	—	—

Model		Sedan									
		2.5 L DOHC high power turbo									
		STI Ltd+L			STI Ltd+W						
		6MT									
OP code		U4	C0	C0	U4	U4	C0	C0	C0	C4	
		MF	MF	HF	ME	MF	LD	MF	HF	TF	
Curb weight (C.W.)	Total	k g (l b)	1,59 4 (3,51 4)	1,59 4 (3,51 4)	1,59 4 (3,51 4)	1,60 0 (3,52 7)	1,60 0 (3,52 7)	1,58 3 (3,49 0)	1,60 0 (3,52 7)	1,60 0 (3,52 7)	1,605 (3,53 8)
	Front	k g (l b)	934 (2,05 9)	934 (2,05 9)	934 (2,05 9)	932 (2,05 5)	932 (2,05 5)	927 (2,04 4)	932 (2,05 5)	932 (2,05 5)	932 (2,05 5)
	Rear	k g (l b)	660 (1,45 5)	660 (1,45 5)	660 (1,45 5)	668 (1,47 2)	668 (1,47 2)	656 (1,44 6)	668 (1,47 2)	668 (1,47 2)	673 (1,48 3)
Gross vehicle weight (G.V.W.)		k g (l b)	2,00 (4,40 9)	2,00 (4,40 9)	2,00 (4,40 9)	2,00 (4,40 9)	2,00 (4,40 9)	2,00 (4,40 9)	2,00 (4,40 9)	2,00 (4,40 9)	2,000 (4,40 9)
Maximum permissible axle weight (G.A.W.)	Front	k g (l b)	1,07 5 (2,37 0)	1,07 5 (2,37 0)	1,07 5 (2,37 0)	1,07 5 (2,37 0)	1,07 5 (2,37 0)	1,07 5 (2,37 0)	1,07 5 (2,37 0)	1,07 5 (2,37 0)	1,075 (2,37 0)
	Rear	k g (l b)	1,04 0 (2,29 3)	1,04 0 (2,29 3)	1,04 0 (2,29 3)	1,04 0 (2,29 3)	1,04 0 (2,29 3)	1,04 0 (2,29 3)	1,04 0 (2,29 3)	1,04 0 (2,29 3)	1,040 (2,29 3)
Option	Genuine leather seat		—	—	—	—	—	—	—	—	—
	RECARO seat		○	○	○	○	○	—	○	○	○
	Cold weather package		○	○	○	○	○	○	○	○	○
	Safety view package		—	—	—	—	—	—	—	—	○
	Advanced package		○	○	○	○	○	○	○	○	○
	Performance damper		—	—	○	—	—	—	—	○	—

PRECAUTION

PC

1. Precaution

CAUTION

Please clearly understand and adhere to the following general precautions. They must be strictly followed to avoid minor or serious injury to the person doing the work or people in the area.

1. VEHICLE DYNAMICS CONTROL (VDC)

Handle the VDC as a total system. Do not disassemble or attempt to repair parts which are not instructed in this manual. Follow the directions in this manual when performing maintenance on the VDCCM&H/U. When parts other than those specified are disassembled, it could prevent the VDC system from operating when needed or cause it to operate incorrectly and result in injury.

2. ELECTRONIC PARKING BRAKE

Handle the electronic parking brake as a total system. Do not disassemble or attempt to repair individual parts. When parts are disassembled, it is possible that the electronic parking brake will not operate when needed or cause it to operate incorrectly and result in injury.

3. BRAKE FLUID

If brake fluid gets in your eyes or on your skin, do the following:

- Wash eyes and seek immediate medical attention.
- Wash your skin with soap and then rinse thoroughly with water.

4. RADIATOR FAN

The radiator fan may rotate without warning, even when the engine is not ON. Do not place your hand, cloth, tools or other items near the fan at any time.

5. ROAD TEST

Always conduct road tests in accordance with traffic rules and regulations to avoid bodily injury and interrupting traffic.

6. AIRBAG

To prevent bodily injury from unexpected deployment of airbags and unnecessary maintenance, follow the instructions in this manual when performing maintenance on the airbag components and nearby, around front of the vehicle (radiator panel, front wheel apron, front side frame, front bumper, front hood panel, front fender panel), around side of the vehicle (front door panel, rear door panel, center pillar, rear fender panel, side sill, rear wheel apron), around rear of the vehicle (the rear seat cushion, rear floor pan, rear sub frame assembly) and the airbag wiring harnesses and nearby.

To prevent unexpected deployment, turn the ignition switch to OFF and disconnect the ground cable from battery, then wait at least 60 seconds to discharge electricity before starting work. Removing or installing the components or the connectors with the ignition switch ON will electrically impair them.

7. AIRBAG AND SEAT BELT PRETENSIONER DISPOSAL

To prevent bodily injury from unexpected airbag deployment, do not dispose the airbag modules or seat belt pretensioner in the same way as other waste. Follow the special instructions for disposal in this manual. Follow all government regulations concerning disposal of refuse.

8. AIRBAG MODULE

Adhere to the following when handling and storing the airbag module to prevent bodily injury from unexpected deployment:

- Do not hold the harnesses or connectors to carry the module.
- Do not face the bag in the direction that it opens towards yourself or other people.
- Do not face the bag in the direction that it opens towards the floor or walls.

9. AIRBAG SPECIAL TOOL

To prevent unexpected deployment, always use special tools for the area where the operation with special tools are required.

10. WINDOW

Always wear protective goggles when working around any glass to prevent glass fragments from damaging your eyes.

11. WINDOW ADHESIVE

Always use the recommended or equivalent adhesive when attaching glass to prevent it from coming off and being removed, resulting in accidents and injury.

12. OIL

When handling oil, adhere to the following to prevent unexpected accident.

- Prepare a container and cloth to prevent scattering of oil when performing work where oil can be spilled. If the oil spills, wipe it off immediately to prevent from penetrating into floor or flowing out for environmental protection.
- Follow all government and local regulations concerning disposal of refuse when disposing.

13. FUEL

When handling and storing fuel, adhere to the following to prevent from unexpected accident.

- The fuel is flammable. Do not put it close to a fire or spark.
- Prepare a container and cloth to prevent scattering of fuels when performing work where fuels can be spilled. If the oil spills, wipe it off immediately to prevent from penetrating into floor or flowing out for environmental protection.
- Follow all government and local regulations concerning disposal of refuse when disposing.

14. ENGINE COOLANT

When handling engine coolant, adhere to the following to prevent from unexpected accident.

- Never remove the radiator cap since engine coolant may blow out when it is hot.
- Prepare a container and cloth to prevent scattering of engine coolant when performing work where engine coolant can be spilled. If the oil spills, wipe it off immediately to prevent from penetrating into floor or flowing out for environmental protection.
- Follow all government and local regulations concerning disposal of refuse when disposing.

15. AIR CONDITIONER REFRIGERANT

In order to prevent from global warming, avoid releasing air conditioner refrigerant into the atmosphere. Using a refrigerant recovery system, discharge and recycle it.

16. REMOVAL AND INSTALLATION OPERATION OF HOSES, ETC.

1. Before the removal and installation operation of hoses, etc.

- If you keep using the damaged or deformed hose, it results bleeds or leakage of the fat adheres or disconnection of the hose. Be careful not to spill fat adheres on exhaust pipes, etc. during maintenance to prevent emitting smoke or causing fires.
- Perform the operation with the hose removed. If the operation is performed without removing the hose, it may damage inner surface of the hose.

2. Removal and installation operation of hoses, etc. during the inspection

• Follow the instructions below when removing hose.

- When removing the hose, do not use a pointed hose remover (hose plucker). Inner portion of the hose can be damaged.

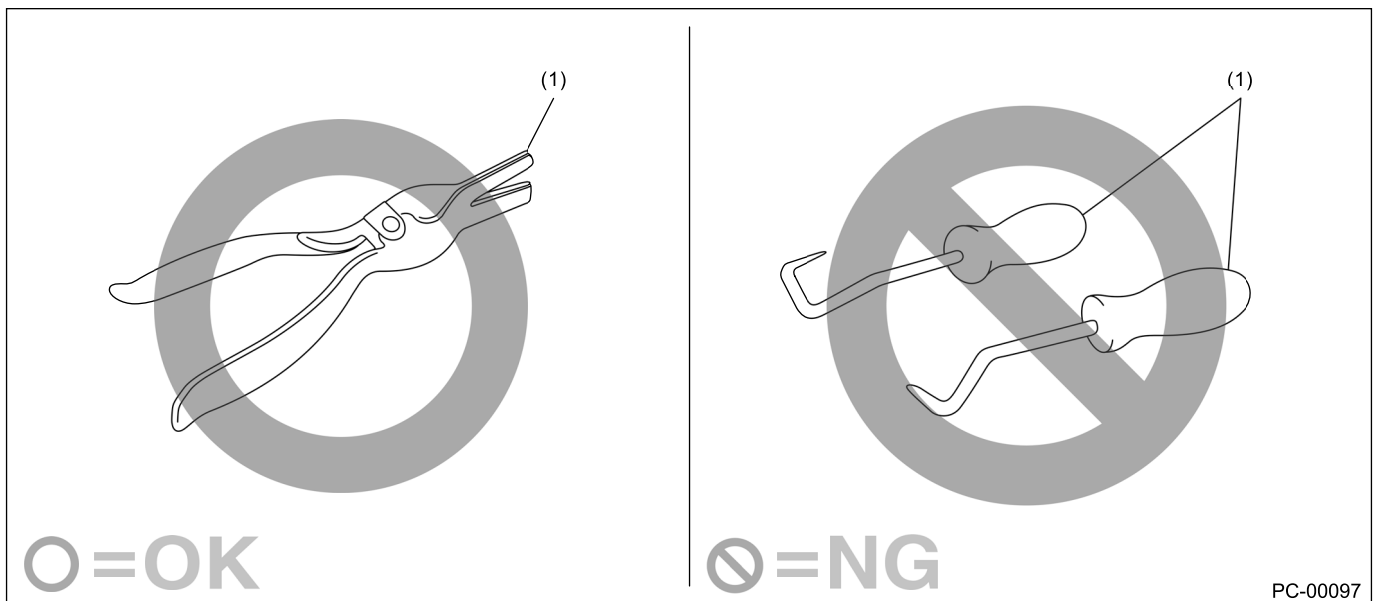

(1) Hose remover

- When removing the hose using pliers, be sure to cover the hose with cloth and rotate the hose slightly to extract straight.
- **If you keep using the hose, perform the inspection below and replace the hose with a new part if faulty.**
 - Replace the hose with a new part if it rides over the stay or the top of spool.

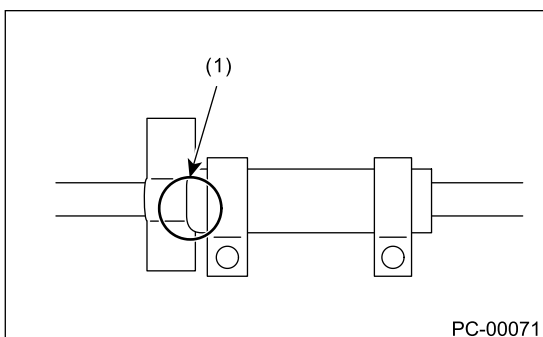

(1) Hose rides over the stay

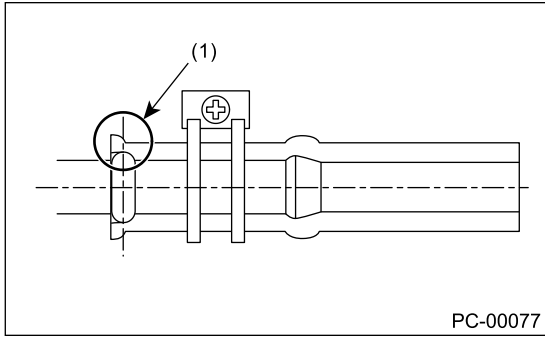

(1) Hose rides over the top of spool

- Check if the surface and the inner surface of the hose are damaged, cracked, bend, hardened, softened, swelled, peeled or deformed due to the adherence or the entry of the foreign matter by bending the hose. Replace with the new part if faulty.
- **Follow the instructions below during installation.**
 - Check carefully for assembling position.
 - Never use lubricants.
 - Insert the hose to the specified position (stopper or spool) securely. (The hose should stop at the position between the spool top and root.)

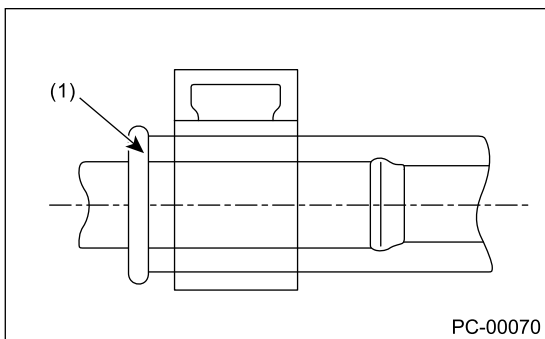
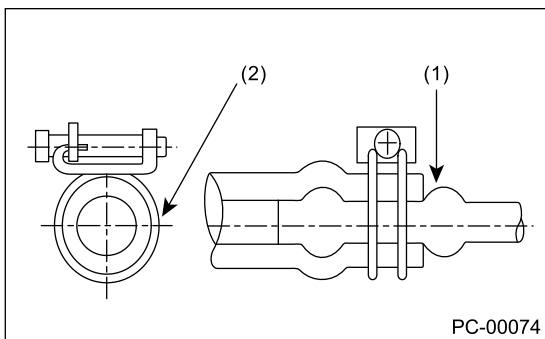

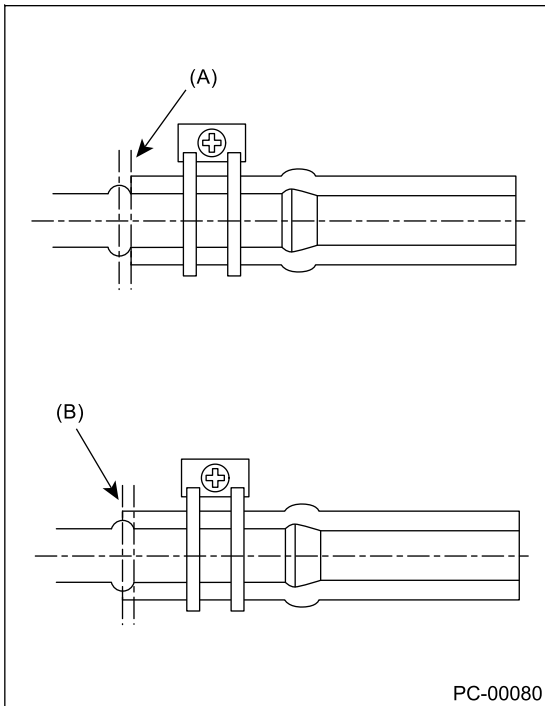

(1) Push against the spool. (Insert the hose and prevent it from becoming wrinkled.)

(2) Fully tighten the hose clamp.

(A) OK position (bottom of spool)

(B) OK position (top of spool)

- Check if the position, direction and hose layout of the hose clamp are correct. (Check if the position, direction, length and the gap around are correct, or if it is different from the condition before the work)
- After the installation, check that the hose is installed securely and there is no leakage. (Check if it is fixed securely with the clamp)
- **For hose clips and hose clamps, perform the inspection below and replace them with a new part if faulty.**
 - Check for deformation, rust, damage or foreign matters.
 - For hose clip, check if it works and has clamping force.
 - For hose clamp, check if it can tighten screw, not ovalized or the screw is not damaged.
- **For hose pipes, perform the inspection below and replace with a new part if faulty.**

Check if the pipe is not damaged, rusted, peeled (peeled plates included), covered with foreign matter, bent, compressed or cracked.
- **For the parts below, replaces with a new part when the hose is removed or the installation position is changed.**

CVTF oil cooler hose, oil hose, power steering suction hose, power steering return hose, fuel hose (delivery/return) (except for those with quick connector)

17. HANDLING PRECAUTIONS FOR SILICON-CONTAINING SPRAY

When a silicon-containing lubricant is used, rust inhibitor or glazing agent adheres to the electrical contact of the relay or switch, which may produce silica dioxide (SiO_2). This may cause poor connection.

- Never spray directly to the electrical equipment.

- When using the spray close to the electrical equipment, always put the cover on it. Special care must be exercised especially when using the spray to the locations shown in the figure below and their surrounding areas.

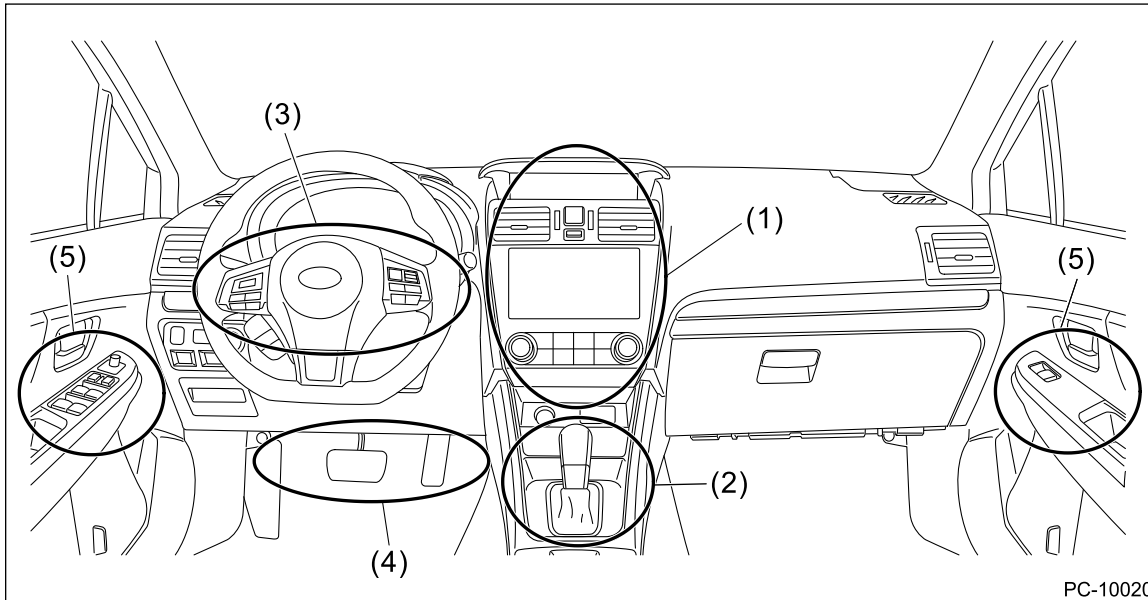

- | | | |
|--|---|-------------------------|
| (1) Audio, heater control switch | (3) Combination switch, steering
switch, paddle shift switch | (5) Power window switch |
| (2) Shift/select lever switch,
parking switch | (4) Stop light switch, brake light
switch, clutch switch, clutch
start switch | |

- If the residual silicon remains in the vicinity of the electrical equipment after the spray has been used, the vaporized silicon stands around the electrical equipment and it may adhere to electrical contact. After using the spray, be sure to wipe the silicon off with a cloth.
- Even when using the spray to the place away from the electrical equipment, the droplet of the spray may be splashed to the periphery. Use as small amount of spray as possible, and take care not to splash the silicon to the periphery.

Note:

The "silicon" used in this section refers to "silicone", that is, silicon polymer.

18. CHECK WINDSHIELD GLASS INCLUDING PROHIBITED AREA FOR MODEL WITH HBA AND EyeSight

1. Prohibited area for sticker attachment and inspection

Do not attach stickers in the prohibited area on the windshield as follows. In addition, there must be no oil film, dirt or scratch in the prohibited area that obstructs the visibility of the stereo camera. Clean the windshield glass if oil film, dirt or fogging is found on the glass, and repair or replace if the windshield is scratched. The vehicle inspection label that is required to be attached on the windshield should be attached on the specified position. If stickers or windshield-related issues adversely affect the visibility of the camera, the functions of HBA and EyeSight may not work properly.

Note:

- **Clean the windshield glass if dirt or fogging is found on the glass. Repair or replace the glass if damage is found.**
- **Be careful not to leave scratch or anything else on the lens.**
- **Do not attach any foreign matter such as oil and fluid.**
- **When cleaning the inner side of the windshield glass, be careful not to touch the lens of the stereo camera. Take care so that the glass cleaner is not applied to the lens. Before starting the operation, cover the camera cover opening with dust-free paper such as copy paper to avoid interference with the camera lens, and attach the paper using tape while being careful not to let the adhesive surface contact the glass surface. Be sure to remove the paper after the procedure. If the lens is touched, replace the stereo camera.**
- **When replacing the windshield glass, be sure to replace the part for the EyeSight.**
- **If the glass is removed or replaced, always perform the stereo camera adjustment and inspection.**

Prohibited area for model with EyeSight (including with HBA)

The illustration below shows from the passenger compartment.

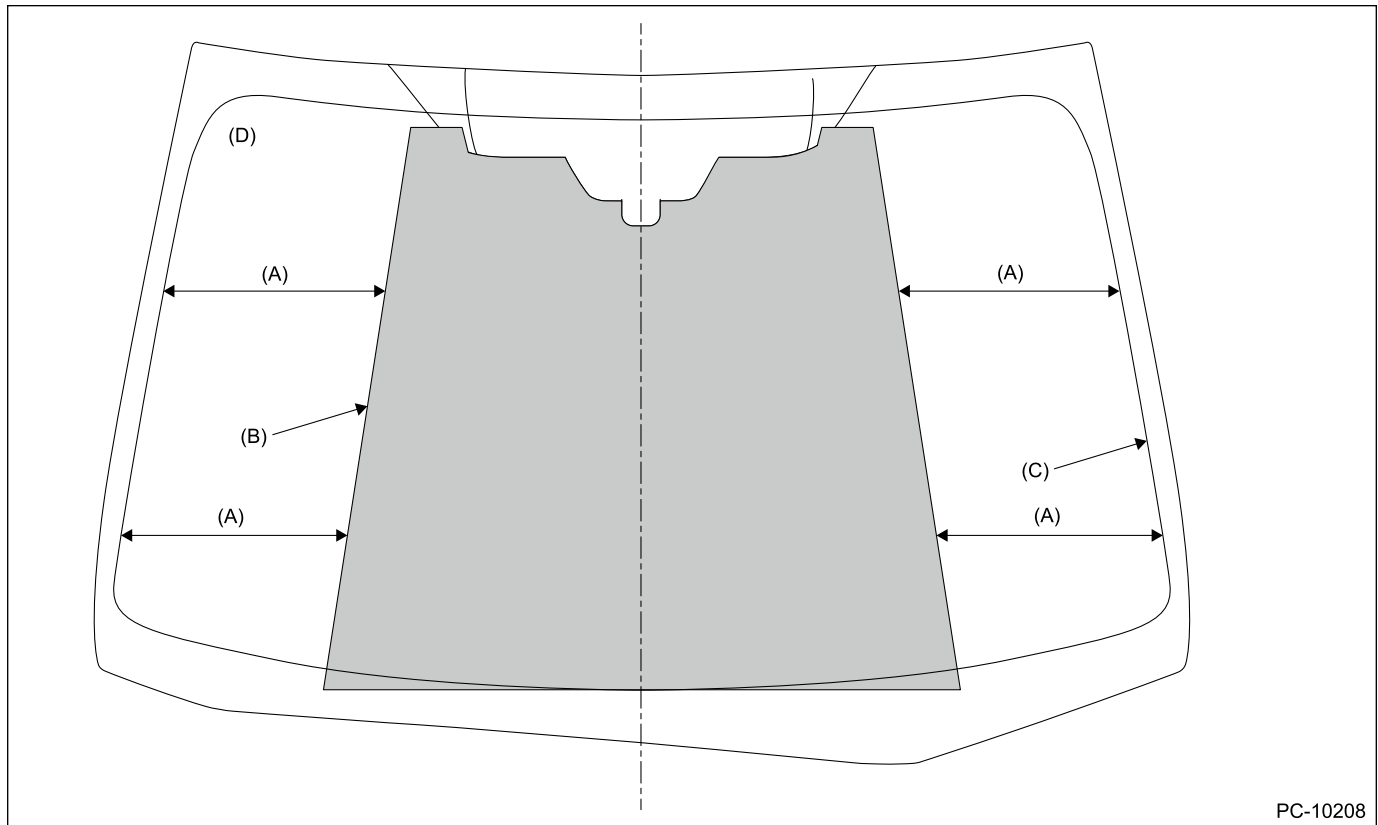

PC-10208

(A) 360 mm (14.2 in)

(C) Ceramic line

(D) Vehicle inspection label

(B) Prohibited area

2. Prohibited area of dashboard and inspection

There must be no oil film, dirt, scratch or fogging that obstructs the forward visibility of the stereo camera. Do not stick or attach the aftermarket parts on the prohibited area (E) shown as follows. If abnormality of the function occurs due to light reflection or glass reflection, even though placed outside the prohibited area, change the attachment position or installation position. Attaching a sticker or antenna or installing a wide type mirror will affect the visibility of the stereo camera, causing the

function not to operate correctly. In addition, placing a navigation system, ETC device or an object on the dashboard will cause reflection on the windshield glass, affecting the recognition of the stereo camera, thus causing the function not to operate correctly.

- Front view

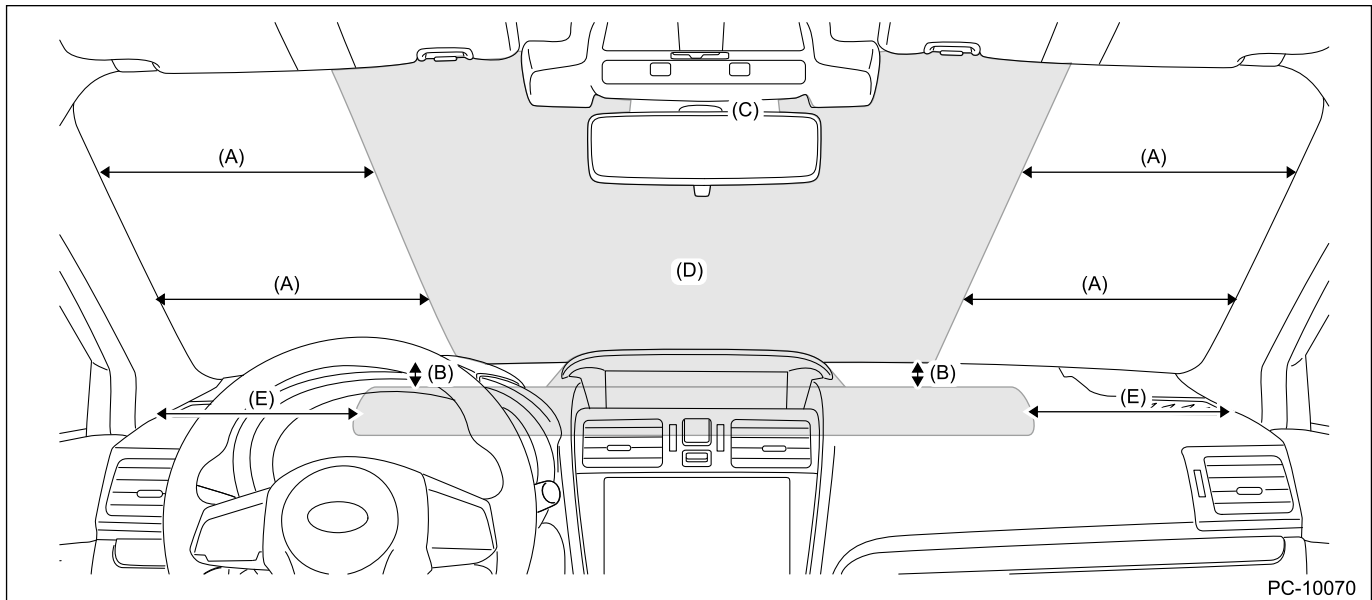

- (A) 360 mm (14.2 in)
- (B) 70 mm (2.8 in)
- (C) Ceramic area
- (D) Prohibited area of windshield
- (E) 230 mm (9.1 in)

- Side view

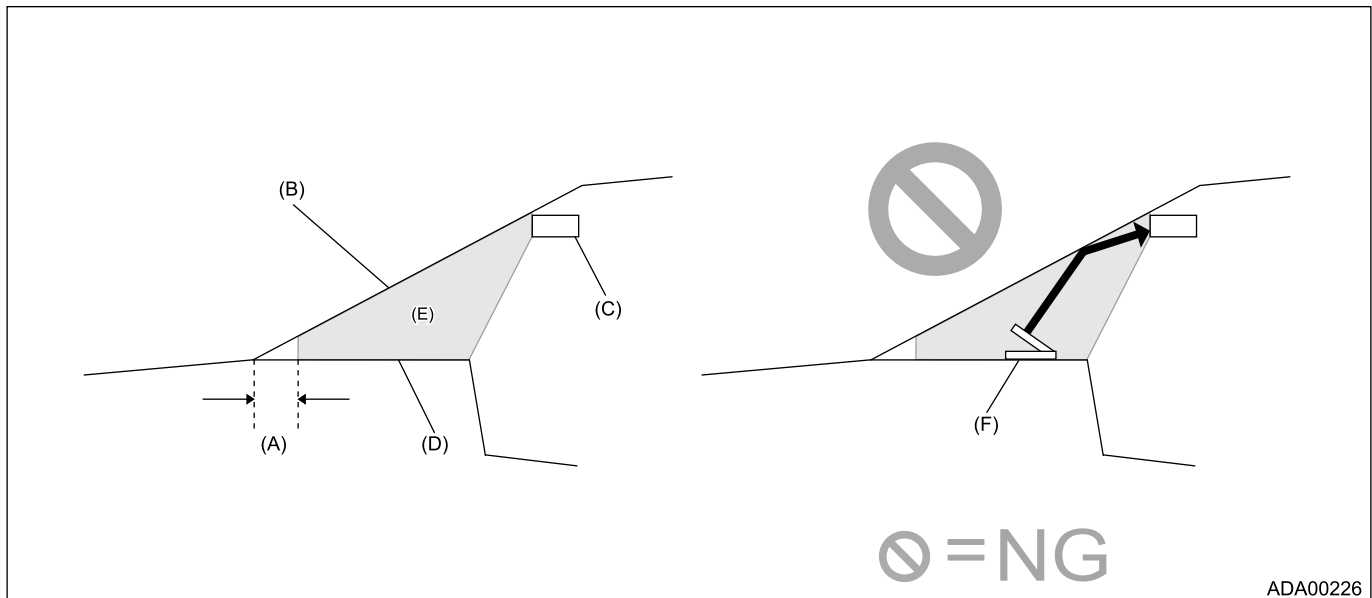

- (A) 70 mm (2.8 in)
- (B) Windshield glass
- (C) Stereo camera cover
- (D) Dashboard
- (E) Prohibited area
- (F) External monitor etc.

3. Prohibited area for repair and inspection

The illustration below shows from the passenger compartment.

If the damage is found in the glass repair prohibited area, always replace the glass. Damage in the prohibited area can affect the recognition of the stereo camera even if it is repaired, and thereby

EyeSight function may not operate properly.

Note:

The center of the glass should be aligned the line connecting "a" and "b" in the figure (the center positions of upper/lower end dotted lines on the black ceramics area).

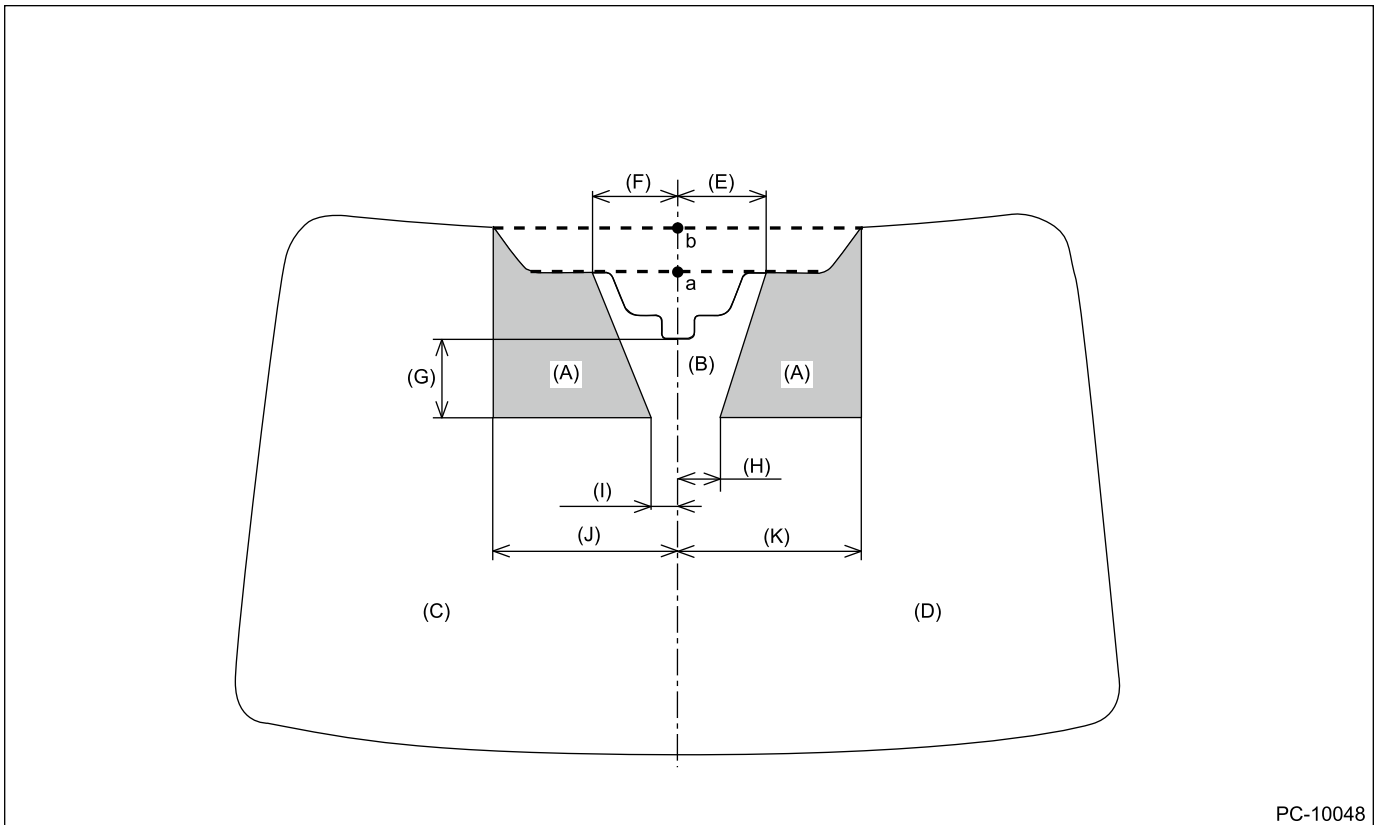

PC-10048

- | | | |
|--|----------------------|----------------------|
| (A) Glass repair prohibited area | (E) 135 mm (5.3 in) | (I) 40 mm (1.6 in) |
| (B) Glass repairable area | (F) 130 mm (5.1 in) | (J) 280 mm (11.0 in) |
| (C) Glass repairable area
(LH side) | (G) 93.6 mm (3.7 in) | (K) 280 mm (11.0 in) |
| (D) Glass repairable area
(RH side) | (H) 65 mm (2.6 in) | |

NOTE

NT

1. Note

NOTE

BASIC REPAIR HINT

This section describes basic points that the service operator must understand before performing the service operation.

1. APPEARANCE

- Always wear clean work clothing.
- Wear a cap and protective shoes.

2. PROTECTION OF VEHICLE UNDER MAINTENANCE AND PREPARATION OF TOOLS/EQUIPMENT

- Before work, cover the vehicle body. (Ex. grille cover, fender cover, seat cover and floor mat cover)
- Before performing the service operation, prepare tools, equipment, container box, grease and cloth etc.

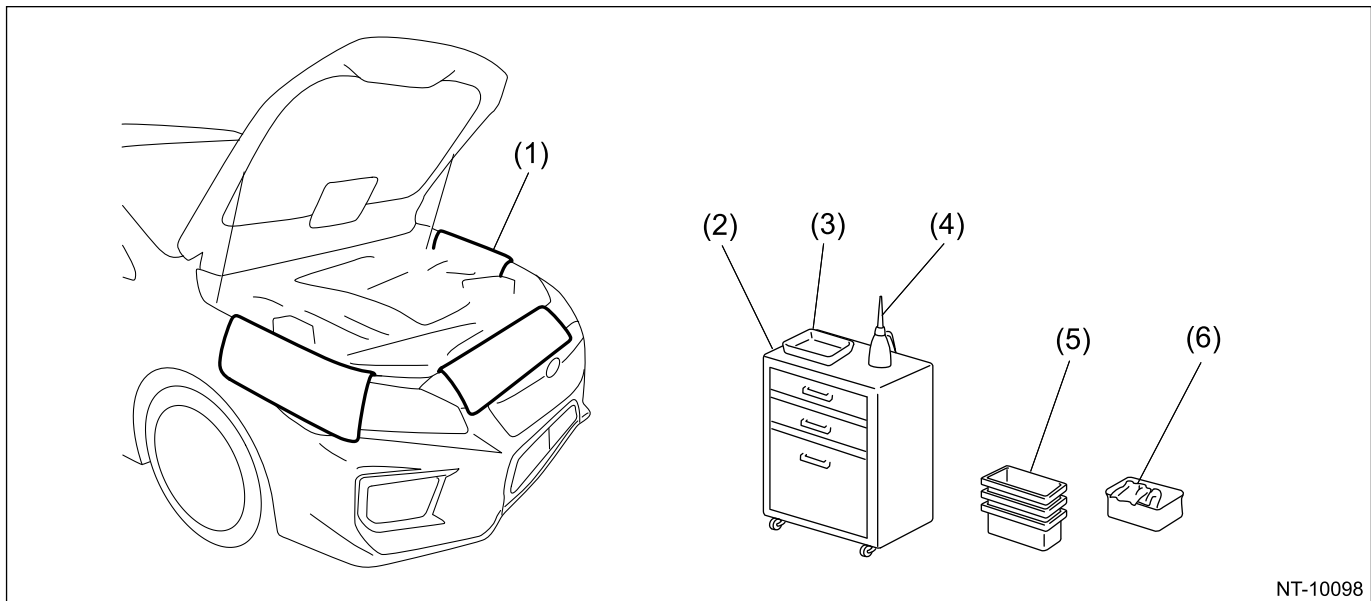

NT-10098

(1) Fender cover

(2) Tools/equipment case

(3) Tray

(4) Oil

(5) Container box

(6) Cloth

3. SAFETY

- Before work, set the wheel stoppers to secure the vehicle.
- When performing work by multiple workers, call to each other to make sure that service operation is performed safely.
- Ventilate the room when starting the engine.
- When performing the service operation of high-temperature parts like muffler, or rotating parts like fan and other movable parts, be careful not to get burned or injured.
- For the jack-up and lift up, set the tool to the proper location to support the vehicle correctly. And use the safety device properly when lifting up.

4. SERVICE OPERATION

- By identifying the vehicle problems thoroughly before service operation, diagnostics work will be performed effectively.
- Before removing parts, confirm the installation condition or the damage of the parts.
- To reinstall parts properly, leave a note of the condition before work as necessary.
- For a part which needs positioning, take appropriate action such as putting alignment marks.
- For a removed part, clean it as necessary and check for damage and defect before installation. If a part is damaged or does not work properly, replace it with a new part.
- Reconnect the harness connectors for each control module one or more minutes after disconnecting them.
- For installation of the bolt, nut, and screws, use tools suitable for each dimension, and use them vertically and securely.
- Removing or installing the components or the connectors with the ignition switch ON will electrically impair them.

5. REMOVED PART

- A removed part must be organized to avoid mixing up with similar parts. When same parts are used in multiple locations, such as pistons in engine, manage the parts by using labels with cylinder No. so that the parts are not installed to the wrong location.
- Always replace nonreusable parts such as gasket and O-ring with new parts.
- After work, have a customer confirm the replaced part.

6. WHEN REMOVING BATTERY

When removing battery, power supply is cut off and the information stored in the computer memory is volatilized. Therefore, setting information of some devices is initialized to the factory default. The device and functions initialized by removing battery are as follows.

No.	Item	Job contents when connecting battery
1	MFD	Set to the date checked before disconnecting the battery.
2	Audio (settings that the customer set)	Set to the contents checked before disconnecting the battery.
3	Navigation system (settings that the customer set)	<ul style="list-style-type: none"> • Time setting is not necessary because the time information is received via GPS. • Set the sound and other settings (items that were set in the selection) to the contents checked before disconnecting the battery.
4	Temperature setting of fully automatic air conditioner (settings that the customer set)	Set to the contents checked before disconnecting the battery.
5	Power window system	Initialize automatic full open/close of driver's and passenger's windows (power window system). For the initialization procedure, refer to "GW" section.  Ref. to GLASS/WINDOWS/MIRRORS>Power Window System>OPERATION.
6	Steering lock system (model with keyless access with push button start)	If the engine does not start, initialize the steering lock system. For the initialization

No.	Item	Job contents when connecting battery
		procedure, refer to "KPS" section.  Ref. to KEYLESS ACCESS WITH PUSH BUTTON START SYSTEM (DIAGNOSTICS)>Diagnostics with Phenomenon>INSPECTION > ENGINE DOES NOT START.
7	EyeSight (model with EyeSight)	Set to the contents checked before disconnecting the battery.
8	Electronic throttle system	Turn the ignition switch to ON, wait for 10 seconds or more, and start the engine.
9	Engine control system	Let the engine run at idle until it fully warms up (the radiator fan turns 2 times or more) under no electrical load condition.
10	Past trouble history (memory code)	—

7. OTHER ADJUSTMENT OPERATIONS BEFORE DELIVERING THE VEHICLE TO CUSTOMER

Due to service and parts replacement convenience, perform the following operations before delivering the vehicle to the customer.

No.	Item	Check operation	Adjustment operation	Additional adjustment operations when replacing parts
1	Positions of devices <ul style="list-style-type: none"> Steering Room mirror Door mirror Seat Air conditioner vent grille 	Is the device set to the same position when the vehicle was received from the customer?	Adjust the device to the similar position when the vehicle was received from the customer.	When removing/installing each device <ul style="list-style-type: none"> Meter, instrument panel, steering column, etc. Room mirror, roof trim, sunroof assembly, etc. Door mirror, door panel, etc. Seat, floor carpet, parking brake lever, etc. Vent grille, instrument panel, console box, etc.
2	Positions of switches <ul style="list-style-type: none"> SI-DRIVE Wiper, light (AUTO or OFF) Headlight beam leveler Illumination control Room light Seat heater, etc. 	Is the switch set to the same position when the vehicle was received from the customer?	Set the switch to the same position when the vehicle was received from the customer.	When removing/installing each switch

NOTE

NOTE

This information will improve the efficiency of maintenance and assure the sound work.

1. CLEANING

- Perform the operation in a clean location and use extra caution in dust proofing.
- Clean the items (except for assembly components) with steam, etc. before disassembly. During steam cleaning, wrap the air breather, oil level gauge, connectors, etc. with vinyl tape to prevent steam from entering inside the parts.
- Use an appropriate cleaning solvent.
- Do not clean rubber parts such as O-ring, gasket and oil seal with cleaning solution.

2. FASTENERS NOTICE

Fasteners must be tightened to the specified torque.

Do not apply paint, lubricant, rust retardant or other substance to the surface around bolts, nuts, etc. in order to avoid loosening.

3. ABOUT SCREWS

Use an appropriate sized tool. Insert a screw vertically into the hole. Check for any loose screws after installation.

If improper tools are used or screws are inserted obliquely to the hole, the screws cannot be installed correctly, which may result in insufficient tightening force or damage on the hole.

4. STATIC ELECTRICITY DAMAGE

Do not touch the control modules, connectors, logic boards and other such parts when there is a risk of static electricity. Always use a static electricity prevention cord or touch grounded metal for the elimination of static electricity before conducting work.

5. TROUBLESHOOTING OF ELECTRICAL SYSTEM

1. Always refer to "CAUTION" of "General Description" in the same models service manual before starting the diagnostics and repair.
2. Always refer to the cautions of each section when diagnosing and repairing each system and component.
3. The battery cable must be disconnected from the negative terminal after the ignition switch is set to the OFF position, unless otherwise required by the diagnostics.
4. When disconnecting a connector, do not pull the harness, but pull while holding the connector housing.

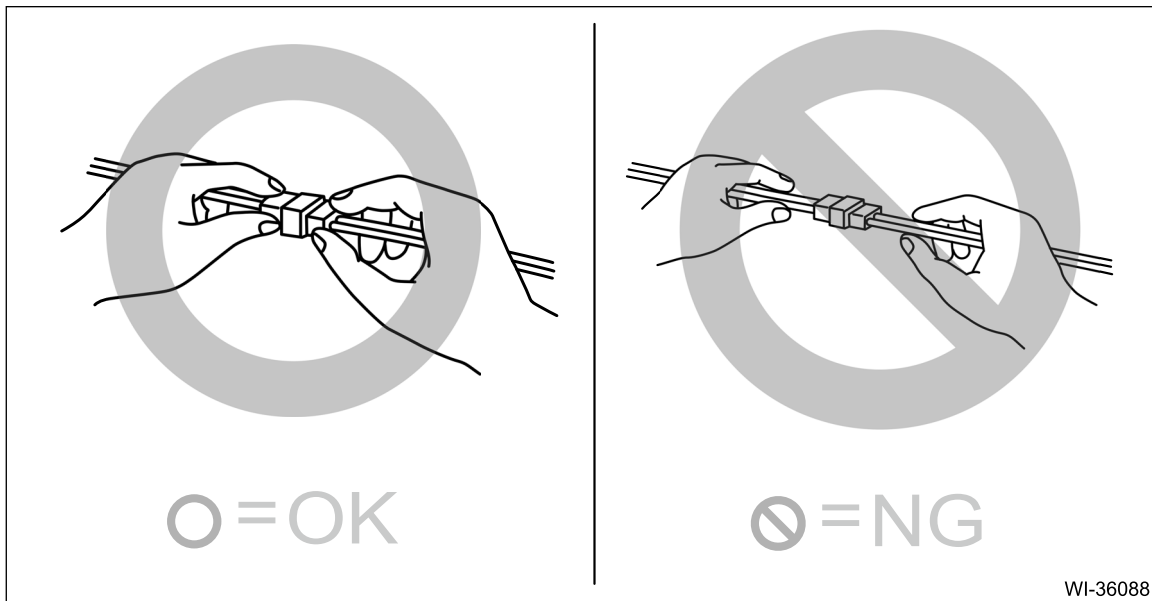

5. Confirm the locking shape completely before disconnecting a connector. In addition, firmly push in the connector until a click sounds when connecting a connector.
6. Be sure to prevent water or oil from contacting the connector terminal of non-fluid connector.
7. When checking continuity between connector terminals, or measuring voltage across the terminal and ground, always touch tester probe(s) to terminals from the harness side.
When measuring the waterproof type connector terminal voltage, or the resistance between the terminals, use the check board.
If the probe is too thick to gain access to the terminal, do not push it in forcibly but use a mini test lead.
8. When measuring the voltage or resistance of individual sensor or all electrical control modules, use a tapered pin with a diameter of 0.6 mm (0.024 in) or less and touch it to the tip of terminal. Never insert the tapered pin into the terminal at this time. Doing so may cause internal deformation and a malfunction can occur.
Caution:
If a taper pin or the like has been inserted into the connector terminal, replace the connector.
9. To check water-proof connectors (which are not measurable from the harness side), touch tester probes on the terminal side and be very careful not to bend or damage the terminals.

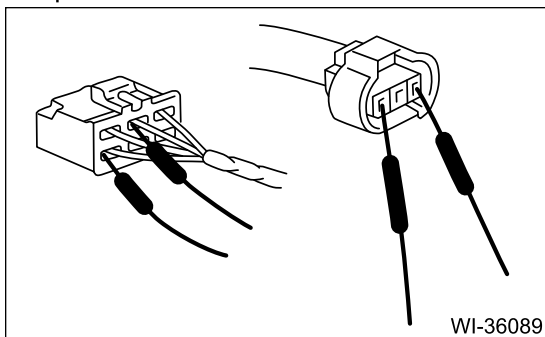

10. Securely fasten the harness with clamps and clips so that the harness does not interfere with the body end parts, edges, bolts or screws.
11. When installing a harness and a component, be careful not to catch them on the harness.

12. Sensors, relays, units, etc., are sensitive to strong impacts. Handle them with extra care so that they are not dropped or mishandled.

13. When inspecting the airbag system, in order to avoid malfunction, always refer to "CAUTION" of "General Description" of the airbag system in the same model's service manual.

6. BATTERY

When removing the battery terminal, always be sure to turn the ignition switch to OFF and disconnect the battery ground terminal first.

• Ground terminal removal or installation (model without battery sensor)

- 1.** Disconnect the ground cable from battery.

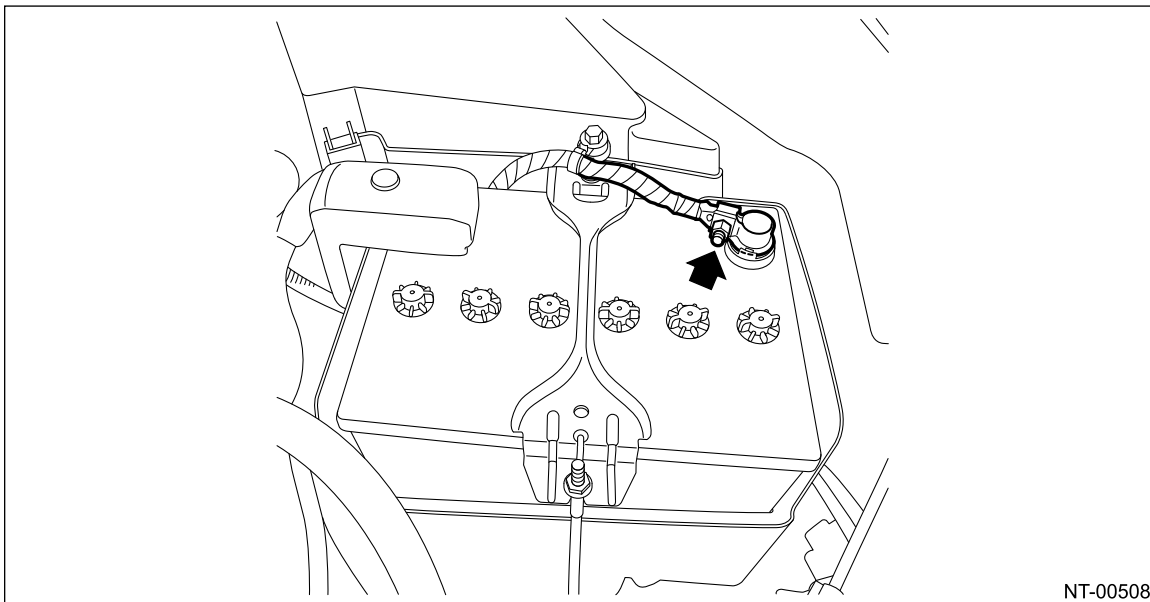

Note:

If necessary, open the trunk before disconnecting the negative terminal of the battery.

- 2.** Connect the battery ground terminal.

Note:

- Clean the battery cable terminals and apply grease to retard the formation of corrosion.
- Connect the positive (+) terminal, and then connect the negative (-) terminal of the battery.
- Since DTCs may be detected, after the battery ground terminal is connected, wait for 10 seconds or more to turn the ignition switch to ON.
- After the battery is installed, initial diagnosis of the electronic throttle control is performed. Wait for 10 seconds or more after turning the ignition switch to ON, and then start the engine.
- For battery replacement procedures, refer to the "SC" section.  [Ref. to STARTING/CHARGING SYSTEMS\(STI\)>Battery>REMOVAL.](#)

Tightening torque:

6.0 N·m (0.6 kgf-m, 4.4 ft-lb)

• Ground terminal removal or installation (model with battery sensor)

- 1.** Disconnect the ground terminal from battery sensor.

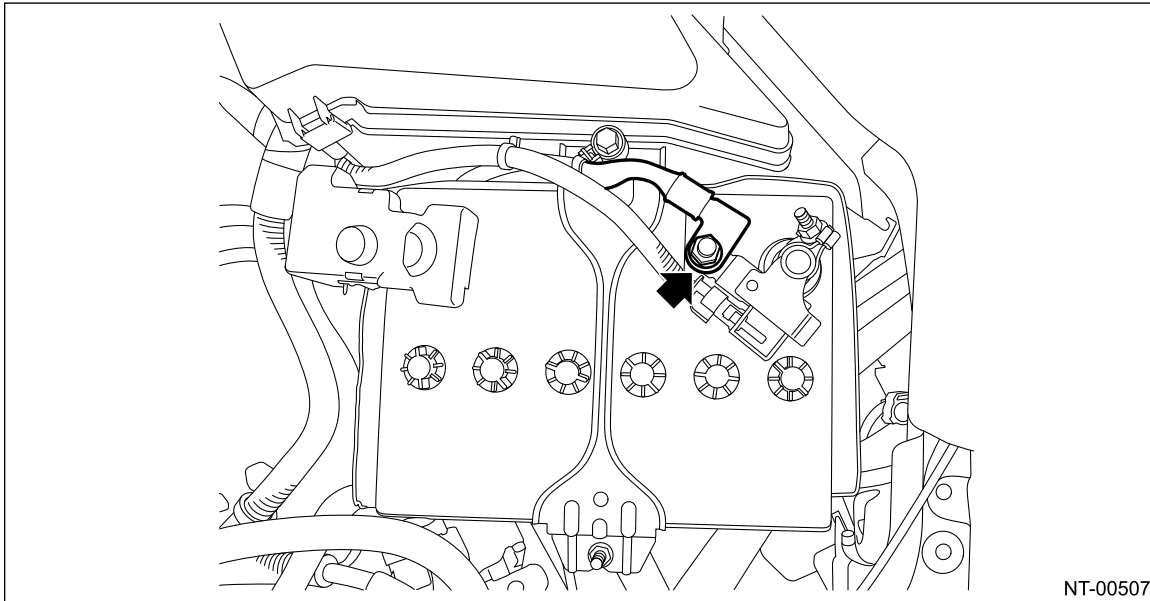

NT-00507

Note:

If necessary, open the trunk before disconnecting the negative terminal or ground terminal of the battery.

2. Install the ground terminal to the battery sensor.

Note:

- **Install the battery sensor while holding it by hand to prevent rotating.**
- **Clean the battery cable terminals and apply grease to retard the formation of corrosion.**
- **Connect the positive (+) terminal, and then connect the negative (-) terminal of the battery.**
- **Since DTCs may be detected, after the battery ground terminal is connected, wait for 10 seconds or more to turn the ignition switch to ON.**
- **After the battery is installed, initial diagnosis of the electronic throttle control is performed. Wait for 10 seconds or more after turning the ignition switch to ON, and then start the engine.**
- **For battery replacement procedures, refer to the "SC" section.  [Ref. to STARTING/CHARGING SYSTEMS\(w/o STI\)>Battery>REMOVAL.](#)**

Tightening torque:

7.5 N·m (0.8 kgf-m, 5.5 ft-lb)

7. BACKUP/POWER SUPPLY FUSE

Backup fuse (20A) remains removed to prevent the battery consumption when vehicles are delivered. Install the backup fuse by following the illustration.

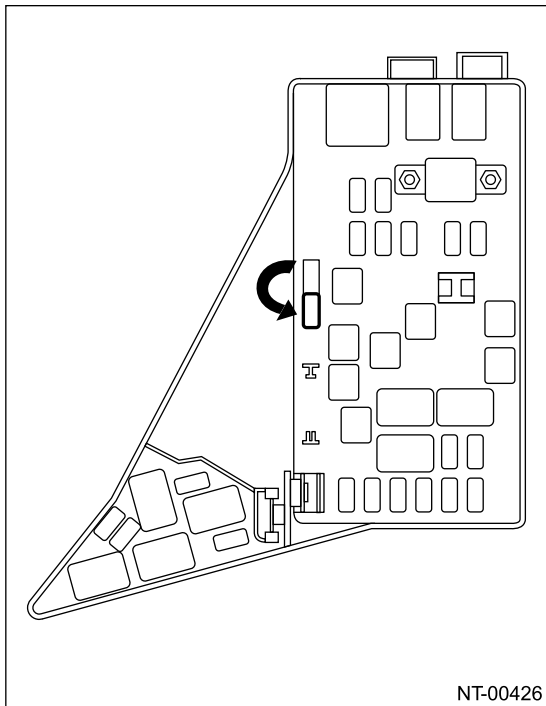

8. IMMOBILIZER RELATED PART

- Do not replace the immobilizer related parts with the parts from other vehicle.
- Registration of the immobilizer is necessary when a immobilizer-related control module has been replaced. For detailed operation procedure, refer to the "REGISTRATION MANUAL FOR IMMOBILIZER" provided as a separate volume.

9. SERVICE PARTS

Use genuine parts for maximum performance and maintenance when conducting repairs. Subaru will not be responsible for poor performance resulting from the use of parts except for genuine parts.

10. PROTECTING VEHICLE UNDER MAINTENANCE

Make sure to attach the fender cover, seat covers, etc. before work.

11. ENSURING SECURITY DURING WORK

When working in a group of two or more, perform the work with calling each other to ensure mutual safety.

12. LIFT AND JACK

When using a lift or shop jack to raise a vehicle or using rigid rack to support a vehicle, always follow instructions concerning jack-up points and weight limits to prevent the vehicle from falling, which could result in injury. Be especially careful that the vehicle is balanced before raising it. Be sure to set the wheel stoppers when jacking-up only the front or rear side of the vehicle.

Caution:

Select the lift attachment so that the spoiler assembly side does not contact the lift arm.

Note:

- When using a lift, follow its operation manual.
- When the spoiler assembly side contacts the lift arm, use a lift attachment.
- Do not work or leave unattended while the vehicle is supported with jack, support it with rigid racks.
- Be sure to use the rigid racks with rubber attached to cradle to support the vehicle.
- When using a lift, use an attachment or something similar.
- When using a plate lift, use a rubber attachment. Place the attachment to the specified position of the vehicle, by adjusting front/rear and left/right sides accordingly.

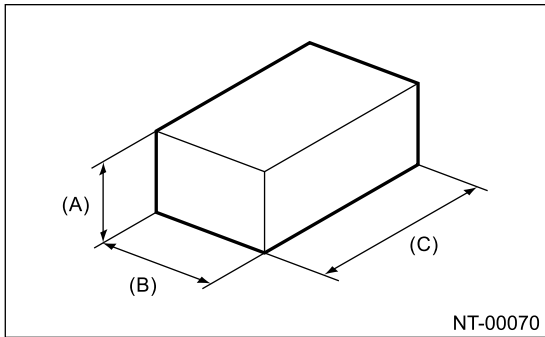

- (A) 80 mm (3.1 in) or more
- (B) 80 – 100 mm (3.15 – 3.94 in)
- (C) 120 – 200 mm (4.72 – 7.87 in)

- Align the cushion rubber center part of plate lift with the center part of rubber attachment.
- Do not use the plate lift whose attachment does not reach the supporting locations.

• **Support locations**

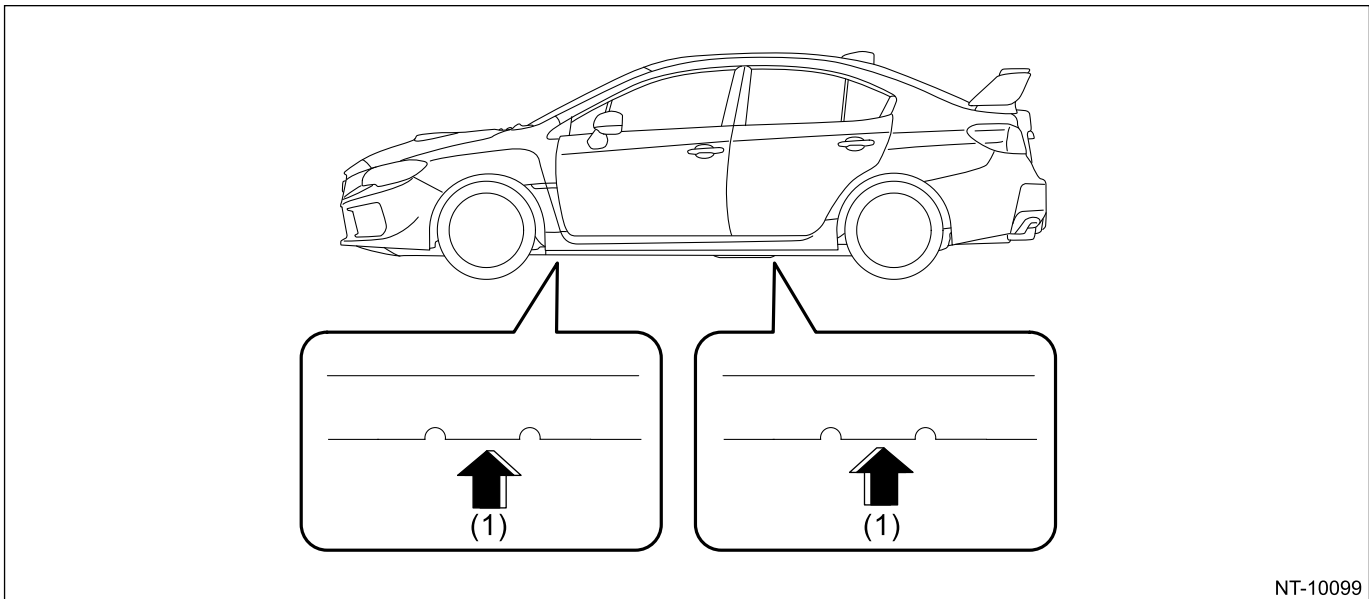

(1) Jack-up point

• **Pantograph jack**

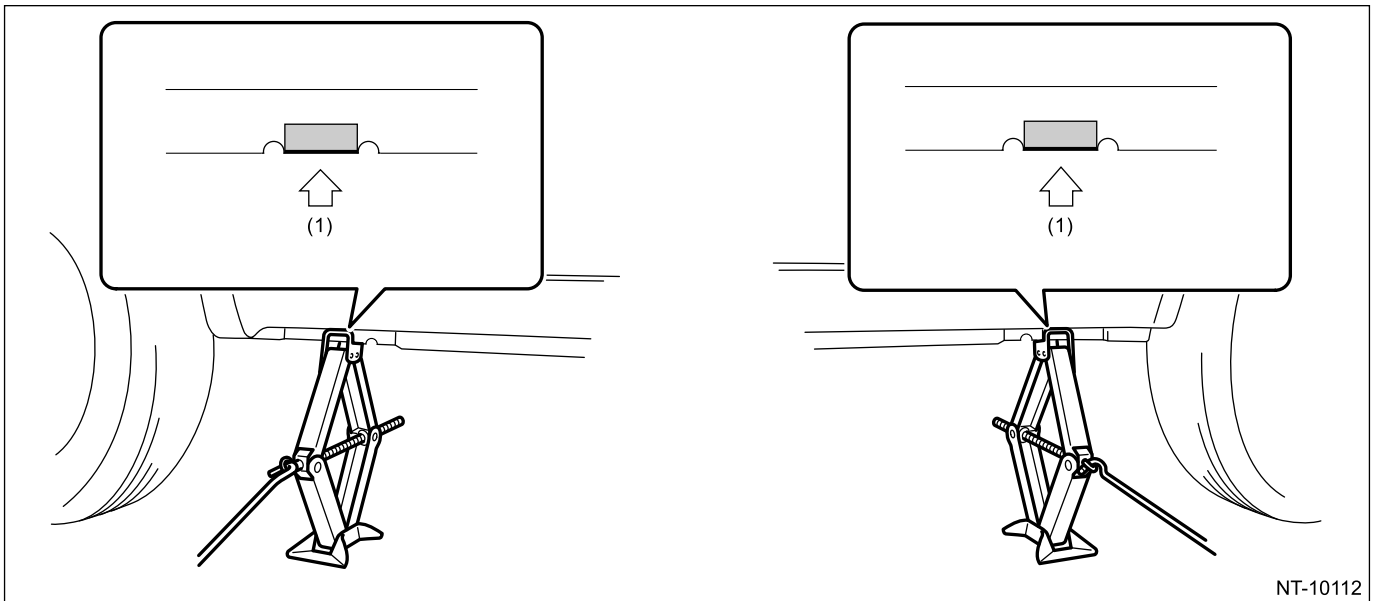

NT-10112

(1) Jack-up point

• **Lift**

Caution:

- Depending on the type of the two-post lift, the spoiler assembly side may contact the arm. In such a case, use the attachment of the regular option for the two-post lift.
- Adjust the rear jack-up point so that the attachment should not contact the chipping guard on the spoiler assembly side.

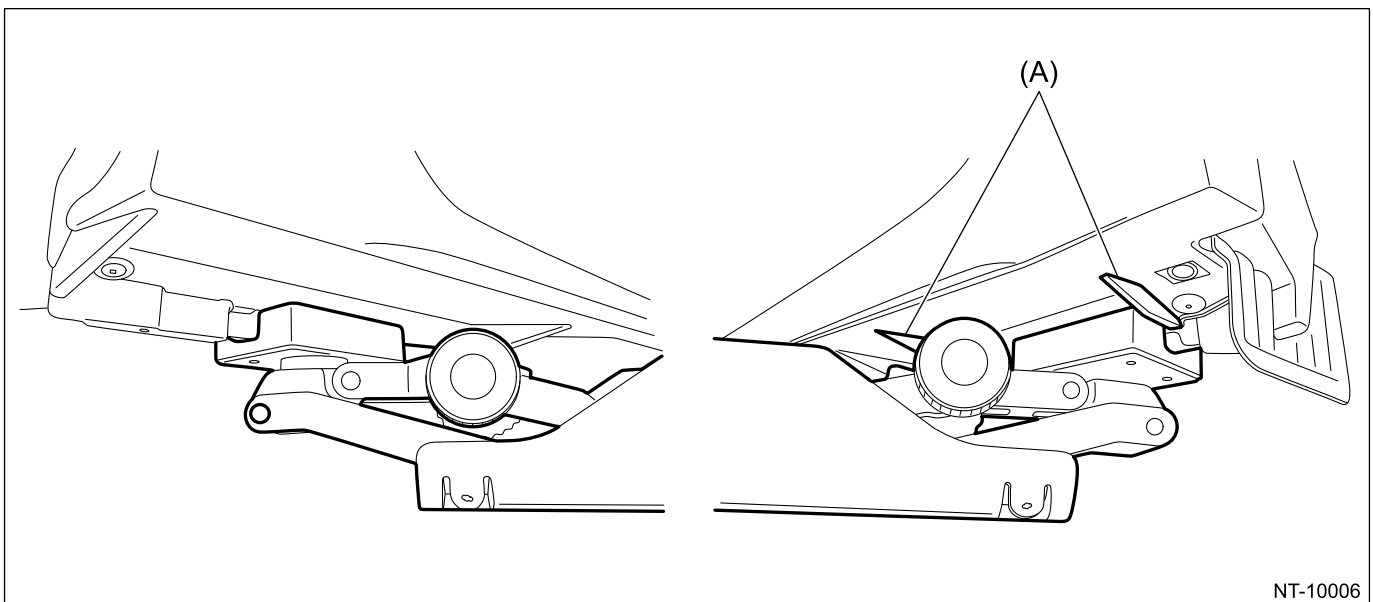

NT-10006

(A) Chipping guard

• **Rigid rack**

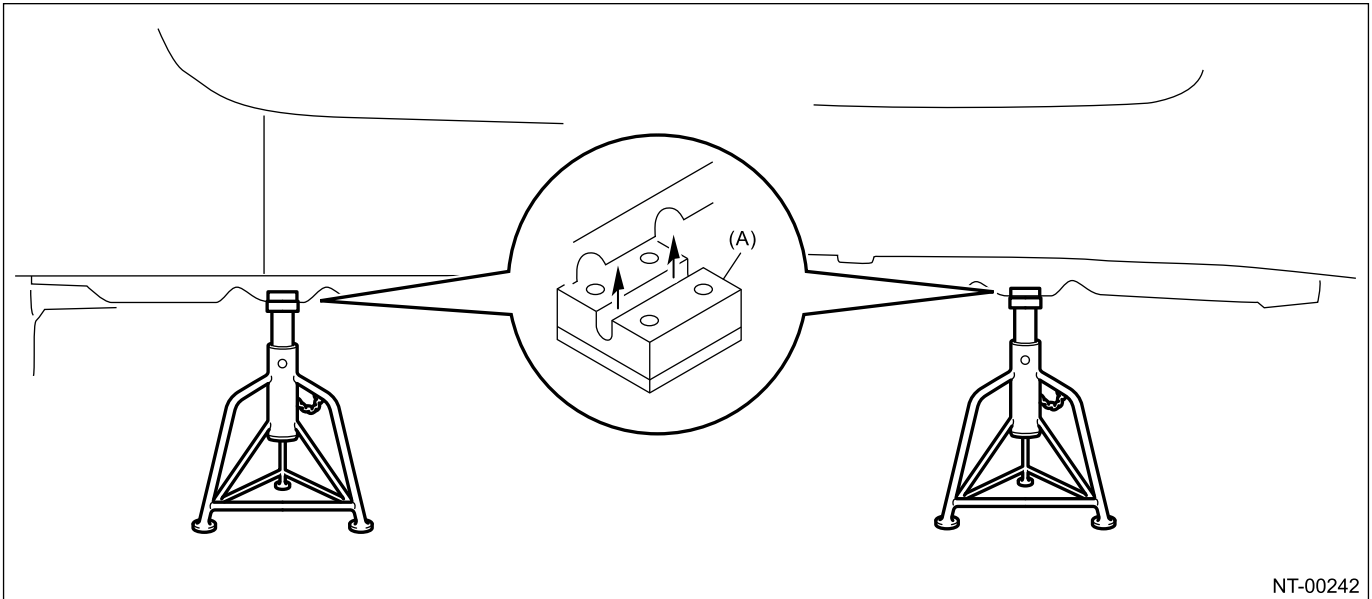

(A) Attachment

• **Plate lift**

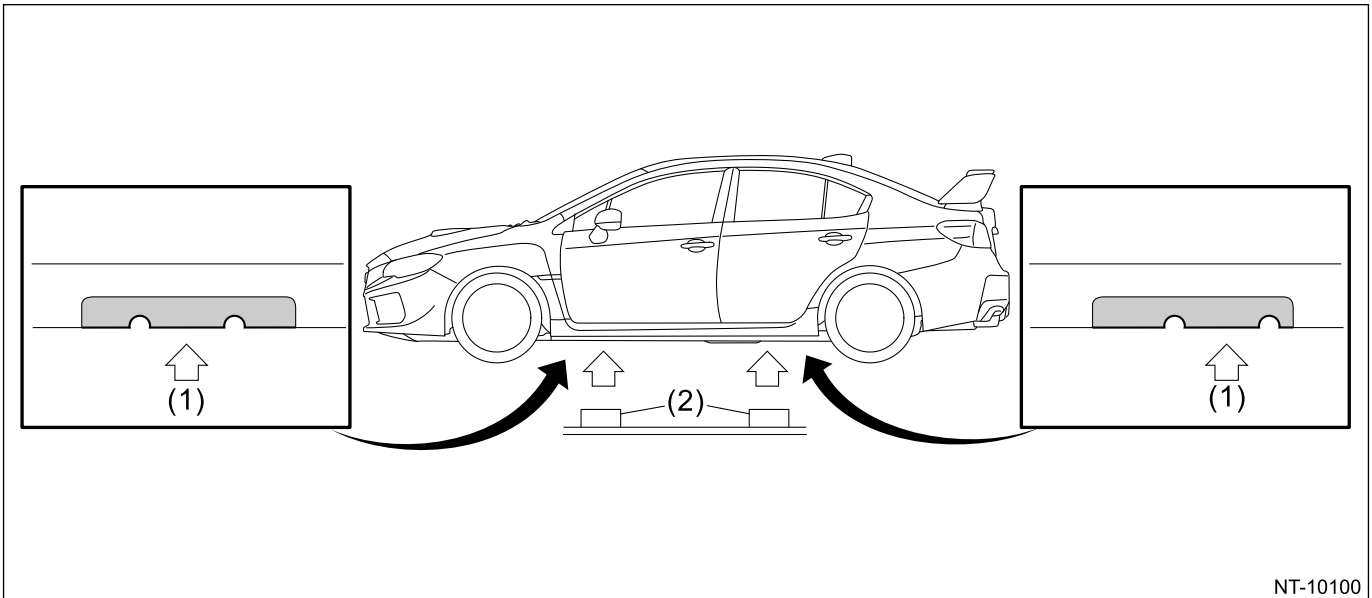

(1) Jack-up point

(2) Attachment

• **Jack-up point (when using a garage jack)**

Caution:

If jacking up the front side of the vehicle, make sure that the jack is attached at the center of the jack-up plate not at the sides.

STI model

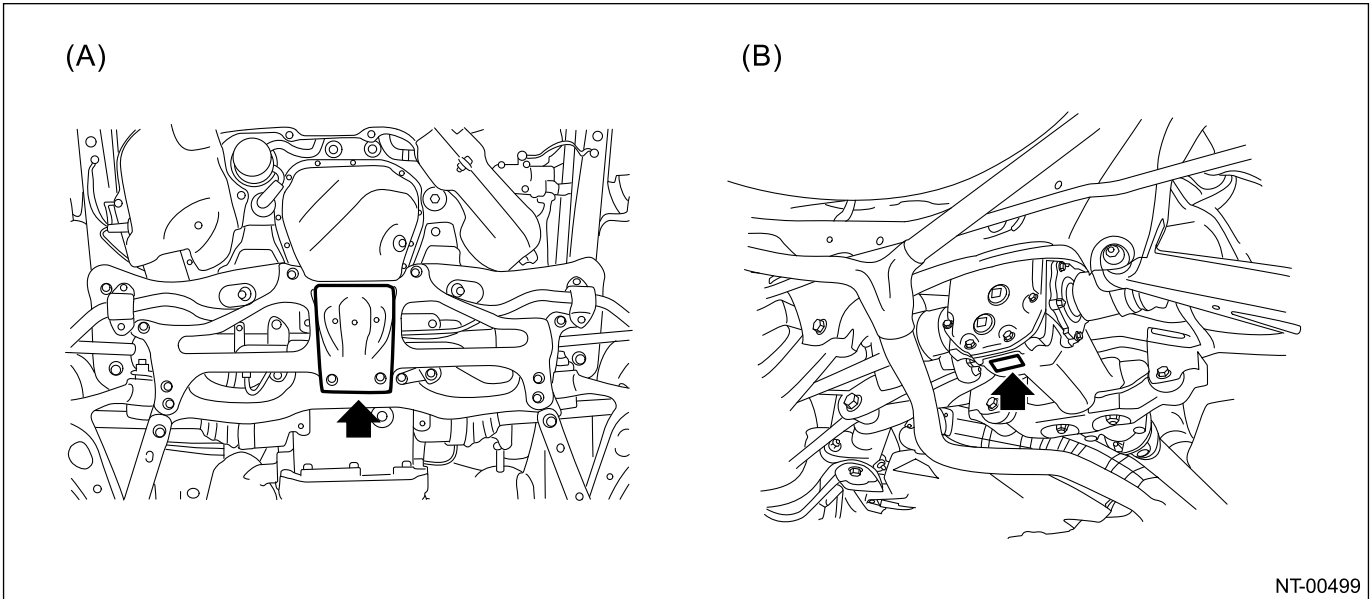

(A) Front (B) Rear
Except for STI model

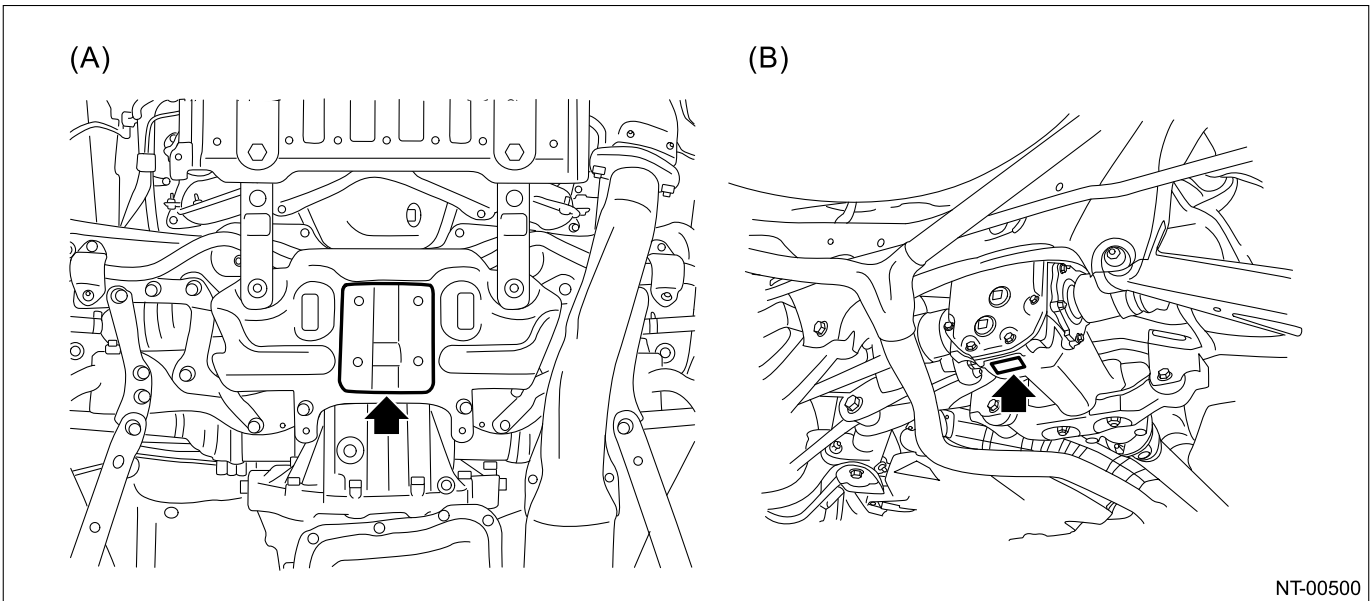

(A) Front (B) Rear

13. TIE-DOWNS

Tie-downs are used when transporting vehicles. Remove the grommet of the tie-down hole and install the tie-down only to the specified locations on the vehicle.

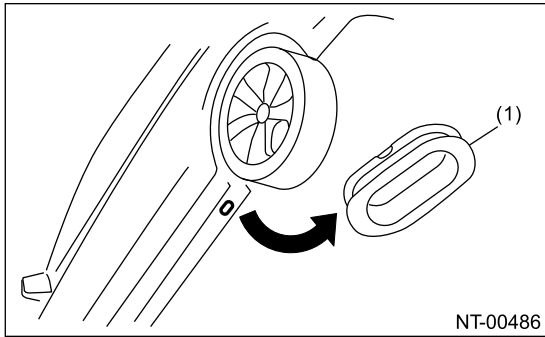

(1) Grommet

● **Tie-down location**

Caution:

Make sure that the rear tie-down hole is firmly plugged with the grommet after the rear tie-down hole is used. Otherwise, dust, smell, etc. may come into the passenger compartment indirectly from the rear quarter, via the side sill from the rear tie-down hole.

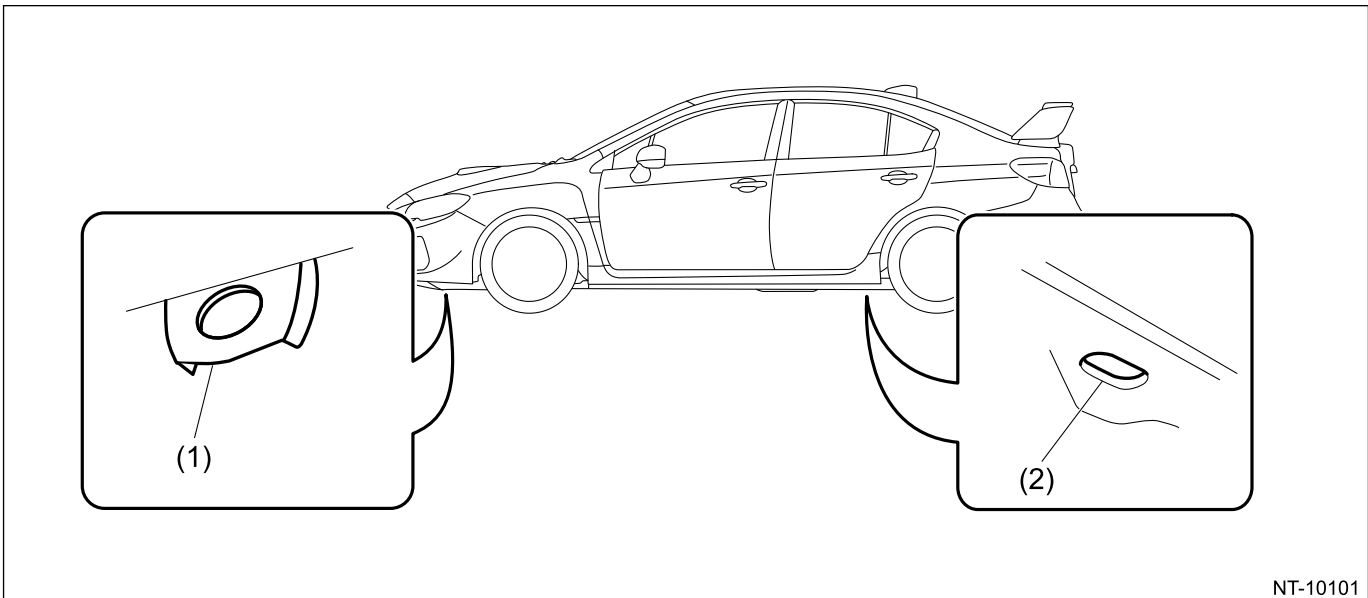

(1) Hook for tie-down

(2) Tie-down hole

● **Chain direction at tie-down condition**

Caution:

- **Pull the front and rear of the vehicle in the opposite direction, and pull the left and right of the vehicle in the same direction.**
- **Patterns except for the followings (recommended) are not allowed.**

Recommended

Tie-down direction

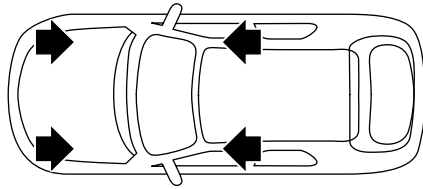
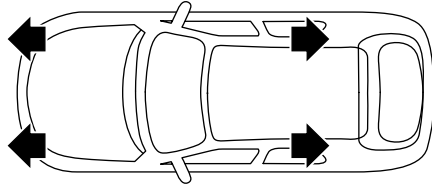

NT-00214

● **Tie-down range**

For ground transportation

Caution:

When the vehicle is tied down from vehicle inside, hook the hooks of tie-down chain on the rear tie-down holes from vehicle inside. When the vehicle is tied down from vehicle outside, hook the hooks of tie-down chain on the rear tie-down hooks from vehicle outside.

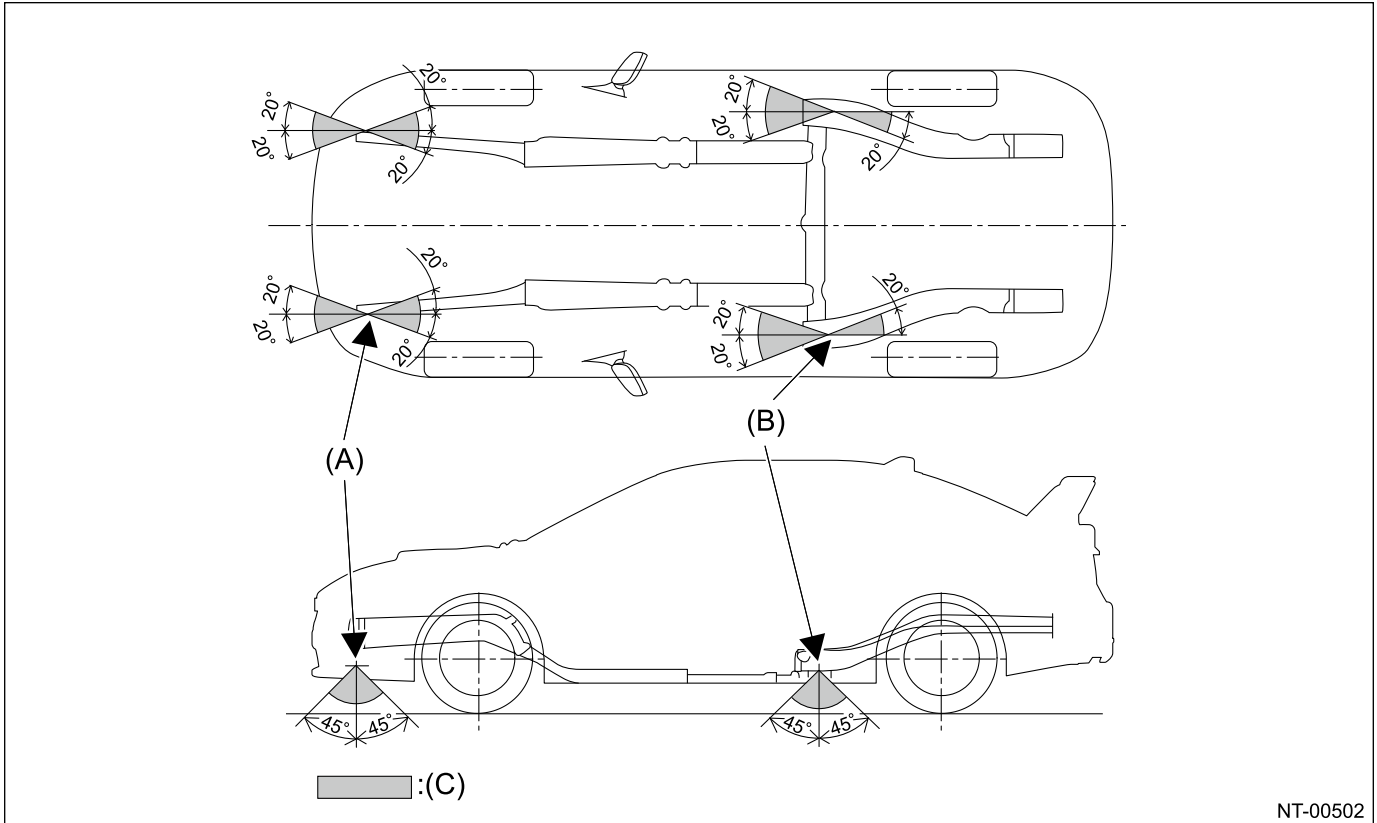

NT-00502

(A) Front tie-down hook

(B) Rear tie-down hole

(C) Chain pulling range at tie-down condition

For sea transportation

Caution:

The eyebolts are exclusively used for towing and sea transportation tie-down, and do not use them for ground and freight transportation.

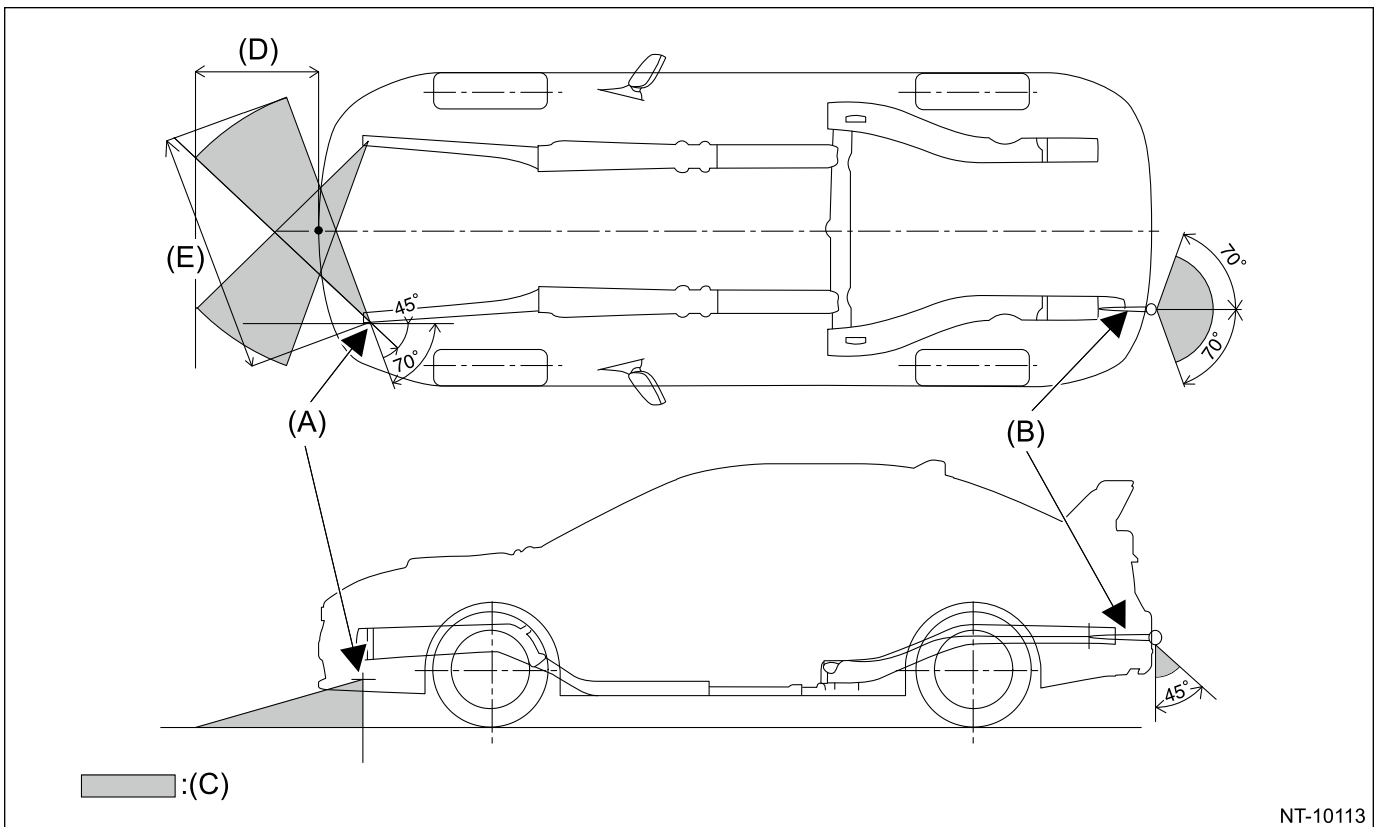

(A) Front tie-down hook

(C) Chain pulling range at tie-down condition

(E) 1,320 mm (52.0 in)

(B) Eyebolt

(D) 400 mm (15.7 in)

- **Vehicle sinking volume at tie-down condition**

Caution:

The vehicle sinking volume at tie-down condition should be less than 50 mm (2 in) and make sure to fix the vehicle securely.

Check to see if the tensions of chains or belts at tie-down condition are appropriate in the following procedures.

1. Before tie-down, measure the distance between the highest tire point and highest arch point at the center of wheel.
2. After tie-down, measure the distance between the highest tire point and highest arch point at the center of wheel.
3. If the distance (A) between the measured value of 1) and 2) above, is less than 50 mm (2 in), it is judged as OK. If the distance is 50 mm (2 in) or more, it is judged as NG because the tension is too high.

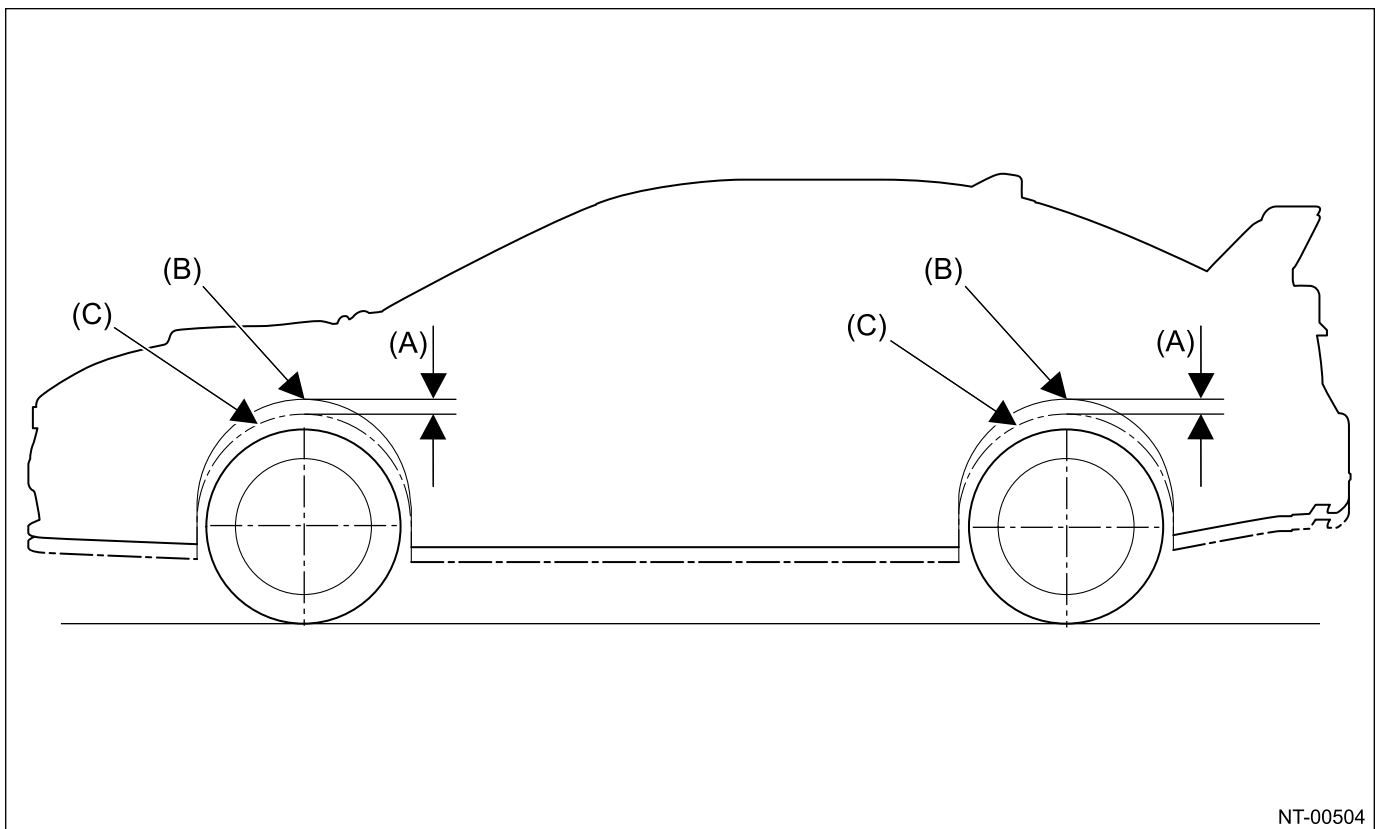

(B) Arch position before tie-down (C) Arch position after tie-down

- **Notes for the use of tie-down hook**

When the vehicle is tied down from vehicle inside, hook the hooks of tie-down chain from vehicle inside, and when the vehicle is tied down from vehicle outside, hook the hooks of tie-down chain from vehicle outside.

For front tie-down hook, use S hook and J hook, and for rear tie-down hole, use S hook, J hook and T hook. T hook can be used only for rear tie-down hole.

14. TOWING

Avoid towing vehicles except when the vehicle cannot be driven. Use a loader instead of towing. When towing other vehicles, pay attention to the following to prevent hook or vehicle damage resulting from excessive weight.

- Do not tow other vehicles with a front tie-down hook.
- Make sure the vehicle towing is heavier than the vehicle being towed.
- When towing the vehicle equipped with Subaru EyeSight, be sure to hold down the pre-collision brake OFF switch to turn OFF the pre-collision brake function. (Check that the pre-collision brake OFF indicator light in the meter lights up.)
- Front
Remove the hook cover, and install the towing hook (eyebolt).

Caution:

Make sure to detach the towing hook (eyebolt) after towing. If the hook remains attached, airbag may not operate properly when receiving a shock from front side. And it may also affect the crash performance of the vehicle.

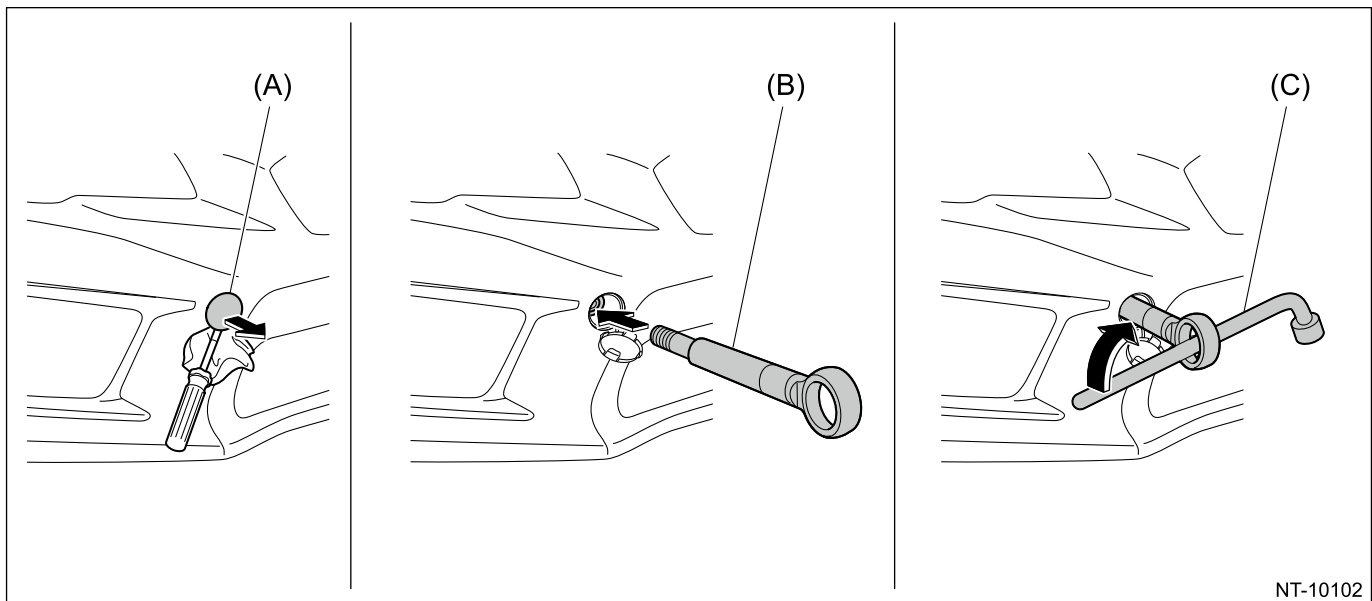

NT-10102

(A) Hook cover

(B) Towing hook (eyebolt)

(C) Wheel nut wrench

- Rear
Remove the hook cover, and install the towing hook (eyebolt).

Caution:

Make sure to detach the towing hook (eyebolt) after towing. If the hook remains attached, the fuel leakage control function of the fuel pump may not operate properly when receiving a shock from rear side. And it may also affect the crash performance of the vehicle.

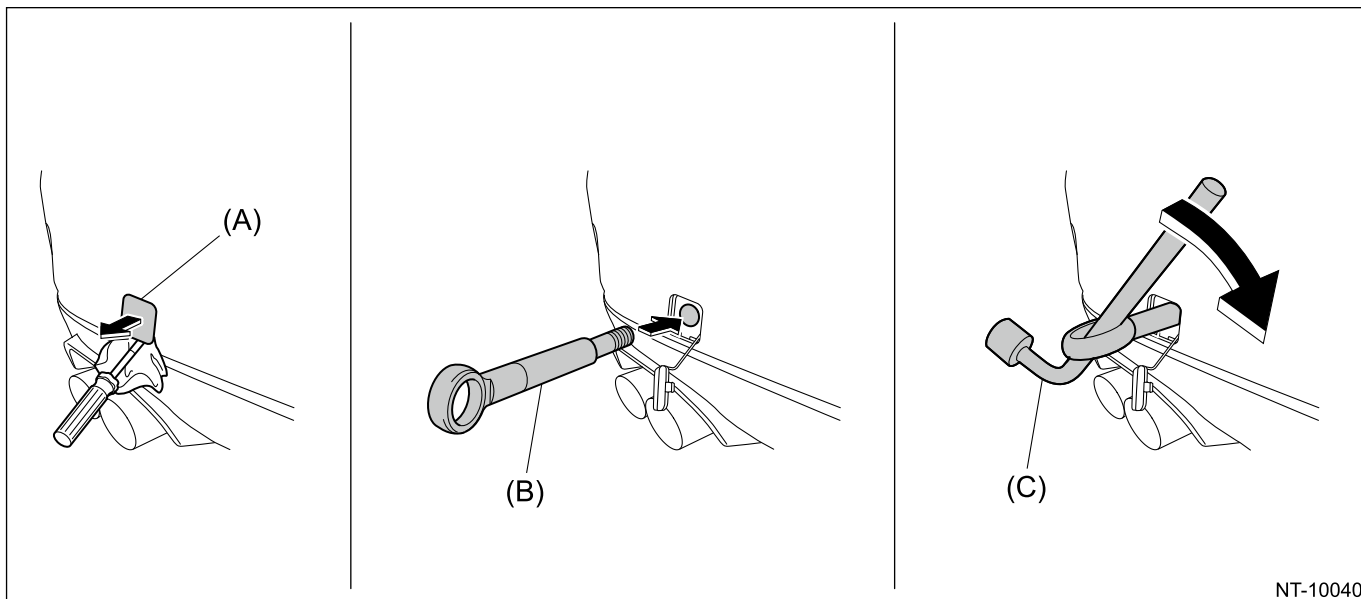



NT-10040

(A) Hook cover rear

(B) Towing hook (eyebolt)

(C) Wheel nut wrench

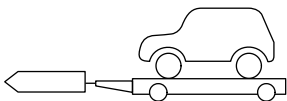
• Precautions

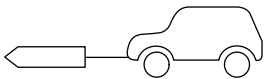
Towing	Precautions	AWD	
		MT	CVT
Lifting up four wheels (on a trailer)  NT-00023	Towing the vehicle after lifting up all four wheels is a basic rule for AWD model. Caution: When loading on a carrier transport, make sure to follow the procedures for "LOADING ONTO CAR CARRIER TRUCK".  Ref. to NOTE>NOTE > LOADING ONTO CAR CARRIER TRUCK.	○	○
Rope  NT-00024	<ul style="list-style-type: none"> • Check if both front and rear wheels are rotated normally. • CVT model driving conditions: Driving speed of 32 km/h (20 MPH) or less Allow driving distance 50 km (31 miles) or less 	○	▲
Raising the front wheels	Prohibited for full-time AWD model.	×	×

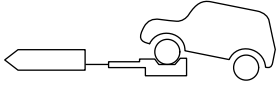
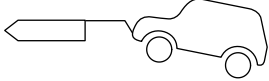
Towing	Precautions	AWD	
		MT	CVT
 <p style="text-align: right;">NT-00025</p>			
<p>Lifting up the front wheels</p>  <p style="text-align: right;">NT-00026</p>	<ul style="list-style-type: none"> • Prohibited, due to damage on bumper, front grille, etc. • Do not raise the vehicle with bumper. 	×	×

Marked ○: OK, Marked ×: Prohibited, Marked ▲: Conditionally OK

Caution:

- Place the shift lever in "N" position during towing.
- Do not lift up the rear wheels to avoid unsteady rotation.
- Turn the ignition key to "ACC", then check the steering wheel moves freely. (Models without the keyless access with push button start)
- Turn the ignition switch to "ACC" or "ON" position, and check that the steering wheel moves freely. (Model with keyless access with push button start)
- Release the parking brake to avoid tire dragging.
- Since the power steering does not work, be careful for the heavy steering effort. (When engine is stopped)
- Since the servo brake does not work, be careful that the brake is not applied effectively. (When engine is stopped)
- In case of the malfunction of internal transmission or drive system, lift up four wheels (on a trailer) for towing.
- Do not use towing hook (eyebolt) except when towing.
- While being towed with all four wheels on the ground, turn the engine switch to ON but do not start the engine.

15. LOADING ONTO CAR CARRIER TRUCK

When carrying the vehicle onto a car carrier truck, observe the following precautions.

Caution:

- When carrying the vehicle onto a car carrier truck, perform the operation being careful with the gap between the height of the carrier's floor and the vehicle lower side because of little clearance under the front bumper.

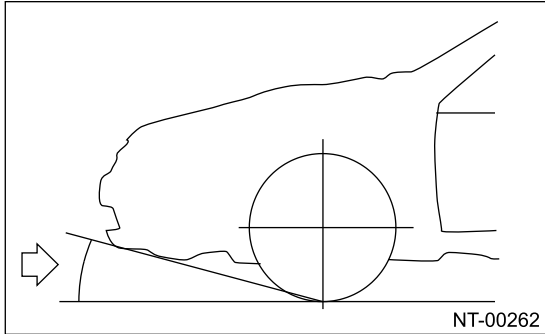

- Use a supporting board (rubber) where the clearance is too small.
- Perform the operation being careful with the position shown in the figure below.

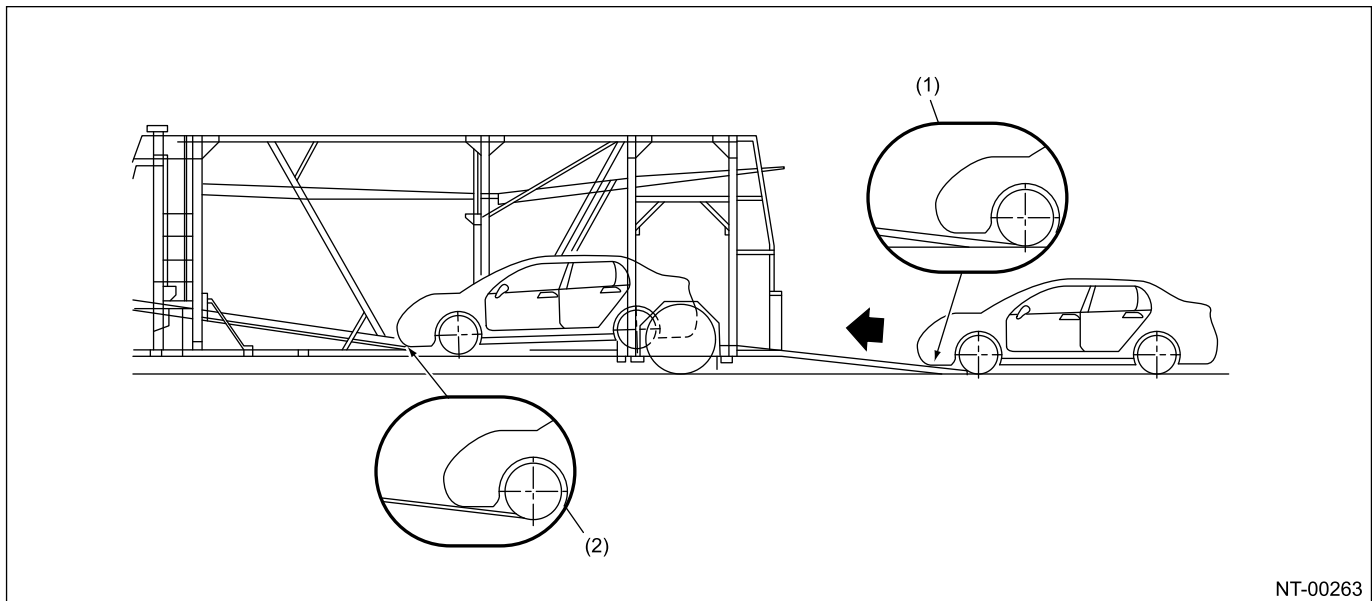

(1) Use a supporting board (rubber) to ensure clearance from the ramp.

(2) Before carrying the vehicle completely, lower the lower center floor until it is level to make clearance.

Before lowering the vehicle from the carrier car, perform the following operations.

Caution:

Always perform the following operations before lowering the vehicle from the carrier car. Otherwise, the power unit will rotate reversely, which may cause the damage to the engine, vacuum pump, and transmission.

1. Start the engine.

2. Set the transmission shift position into driving direction of the vehicle. (When the vehicle drives forward, do not shift the transmission in R range. When the vehicle drives rearward, do not shift the transmission in 1st through 6th gear or D range.)

Caution:

Be sure to perform 2) mentioned above even if the engine cannot be started in some reasons.

16. FRONT HOOD GAS STAY

1. Always perform works such as inspections and maintenance with both gas stays attached.

Caution:

At the inspection and general maintenance, do not detach the gas stays.

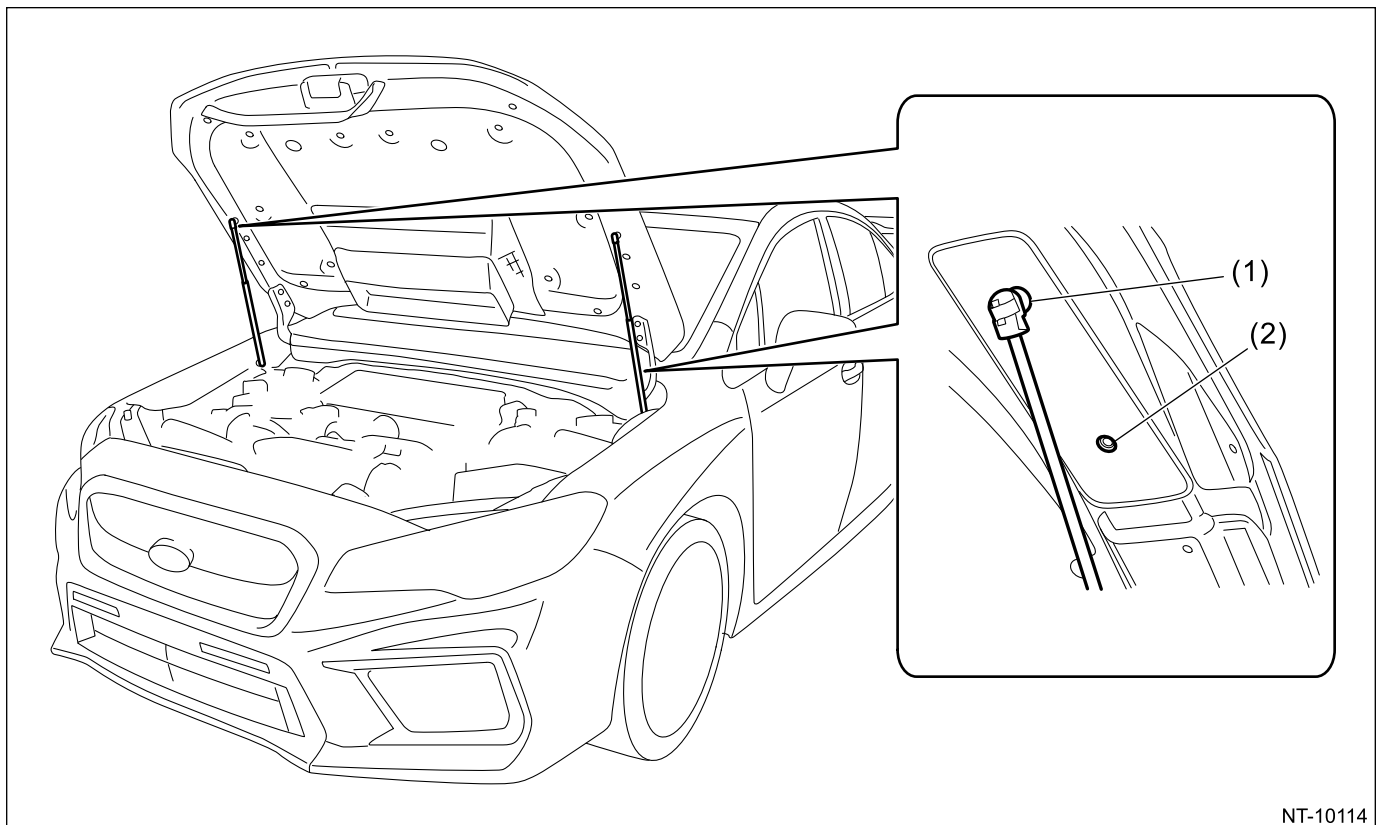

NT-10114

- (1) Normal attached position (2) Installation position at full open

2. When wider hood opening is necessary, set the gas stay below as shown in the figure.

Tightening torque:

 Ref. to [EXTERIOR BODY PANELS>General Description>COMPONENT > FRONT HOOD.](#)

Caution:

- The hood cannot be closed with the hood damper on the full open side. When it is necessary to close, tie the hood striker and the radiator panel with a string etc. to fix them.
- After work, set the gas stays back to the normal position and tighten the bolts to the specified torque.

17. GENERAL SCAN TOOL

Using general scan tools will greatly improve the efficiency of repairing engine electronic controls. Subaru Select Monitor can be used to diagnose the engine, VDC, air conditioner and other electrically controlled parts.

18. AWD CIRCUIT MEASURES

1. Full time AWD 6MT (STI model)
Since the driver's control center differential (DCCD) is used in the center differential, cut-off of AWD circuit cannot be carried out.
2. Full time AWD 6MT (except for STI model)
Since viscous coupling (limited slip differential) is used in the center differential, cut-off of AWD circuit cannot be carried out.
3. Full-time AWD CVT model
Since VTD type is used in the center differential, cut-off of AWD circuit cannot be carried out.

19. SPEEDOMETER TEST

1. Rear wheel free roller system
 - (1) Set the free roller on the floor of rear wheel side securely according to the wheel base and rear tread of the vehicle.
 - (2) Let the vehicle ride on the tester and free roller gently.

Caution:

- **Hold the vehicle using a pulling metal (chain or wire).**
- **Do not operate the accelerator pedal, brake pedal and steering wheel abruptly.**
- **Perform the measurement while driving the vehicle at 50 km/h (31 MPH) or less and complete within one minute.**

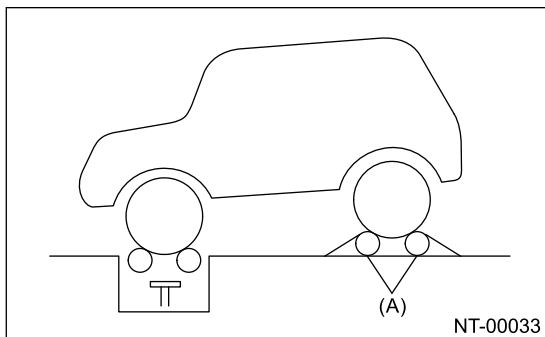

(A) Free roller

- (3) Set the speedometer tester.
 - (4) Conduct the speedometer test work.
2. Rear wheel jack-up system
 - (1) Set the vehicle on speedometer tester.

Caution:

 - **Hold the vehicle using a pulling metal (chain or wire).**
 - **Do not operate the accelerator pedal, brake pedal and steering wheel abruptly.**
 - **Perform the measurement while driving the vehicle at 50 km/h (31 MPH) or less and complete within one minute.**
 - (2) Jack up the rear wheels and set the rigid racks to the specified locations of side sill.

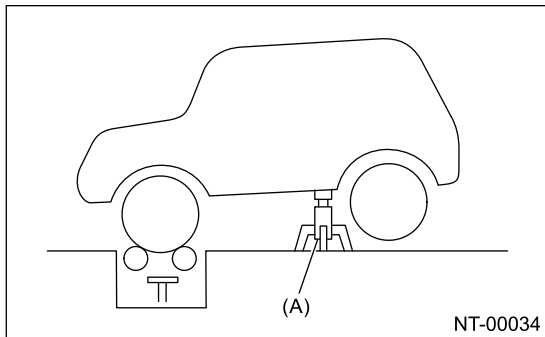

(A) Rigid rack

(3) Conduct the speedometer test work.

20. BRAKE TEST

1. Full time AWD 6MT (except for STI model)

- (1) Perform this test after driving the vehicle 2 to 3 km (1.24 to 1.86 miles) on road in order to stabilize the viscous torque of viscous coupling.
- (2) Keep the front or rear wheels on the ground for this test.

Note:

Effect of the viscous torque on braking force will be added approx. 25 kg compared with FWD model.

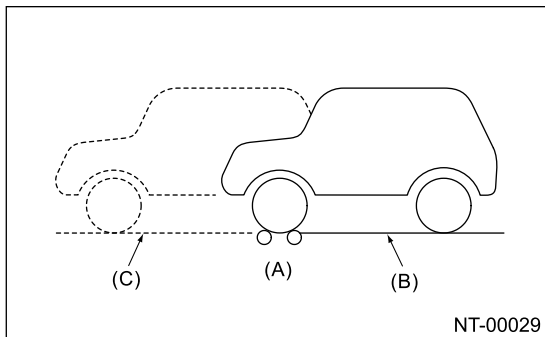

(A) Brake tester

(B) Position for measuring front wheel

(C) Position for measuring rear wheel

(3) When the brake dragging force is large.

- Check the dragging of brake pad or brake shoe.
- Since it may be affected by the viscosity of viscous coupling, jack up either of the front or rear two wheels to check the each wheel rotation condition with the viscous coupling affection removed.

2. Full time AWD 6MT (STI model) and CVT model

- (1) Keep the front or rear wheels on the ground during measurement.

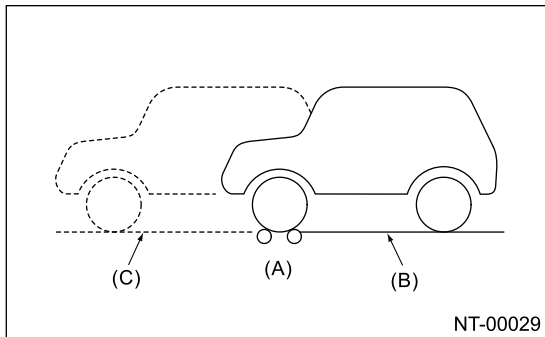

- (A) Brake tester
- (B) Position for measuring front wheel
- (C) Position for measuring rear wheel

(2) When the brake dragging force is large.

- Check the dragging of brake pad or brake shoe.

Specifications:

	Braking force
Rear wheel total	10% or more of load on front or rear wheels
Difference between right and left wheels	8% or less of load on front or rear wheels
Grand total	50% or more of vehicle weight at the time of test

- When measurement is difficult to carry out because both of front wheels are locked, brake force measurement in this condition conforms to standard grand total.

21. ON THE CAR WHEEL BALANCING

Caution:

- Carry out the procedures after measuring the balance of each single tire.
- Set the vehicle so that the front and rear wheels are the same height.
- Make sure that the VDC is deactivated.
- Release the parking brake during measurement.
- Rotate each wheel by hands, and make sure it rotates without dragging.
- Do not operate the clutch quickly and do not accelerate or decelerate suddenly during work.
- When an error is indicated during engine drive, do not use the motor drive together.

1. Set the rigid rack to the specified locations of side sill, jack up the front or rear two wheels of non-measuring side and set the pickup stands to two wheels of measuring side.

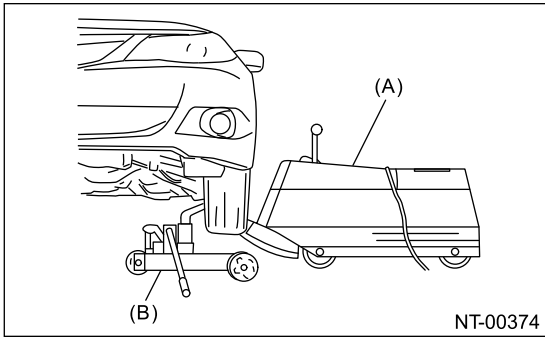

(A) Balancer body

(B) Pickup stand (left and right)

- 2.** For drive wheel, drive the tires with engine for measurement.
- 3.** For non-drive wheel, drive the tires from the on the car wheel balancer for measurement.

IDENTIFICATION

ID

1. Identification

IDENTIFICATION

1. IDENTIFICATION NUMBER & LABEL LOCATIONS

The V.I.N. (Vehicle Identification Numbers) is used to classify the vehicle.

- **Positioning of the plate label for identification**

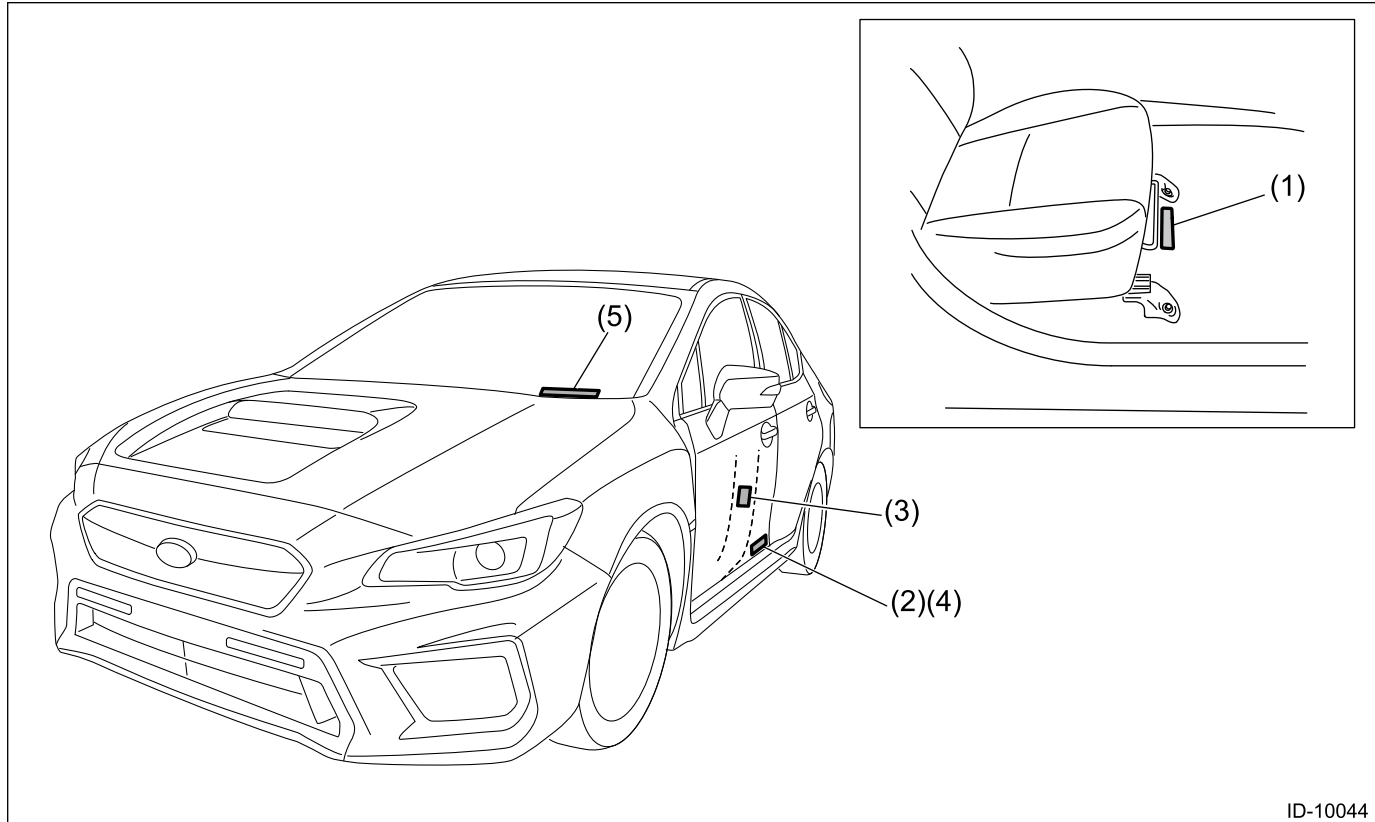

ID-10044

(1) VIN (Vehicle Identification Number) (below right front floor carpet)

(2) FMVSS and CMVSS label (attached to left side of vehicle)

(3) Tire inflation pressure label (driver's side)

(4) Model number label (attached to right side of vehicle)

(5) VIN plate

- **Engine**

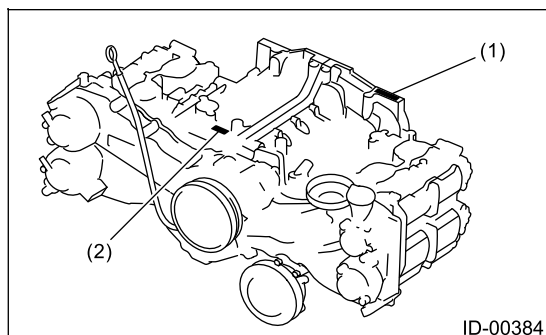

ID-00384

(1) Engine serial number (punch mark)

(2) Engine type (casting) crankcase upper side

• **Automatic transmission**
CVT

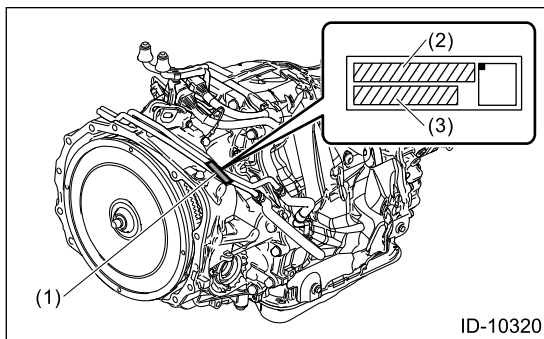

- (1) Label
- (2) CVT type
- (3) Transmission serial No.

• **Manual transmission**
Except for STI model

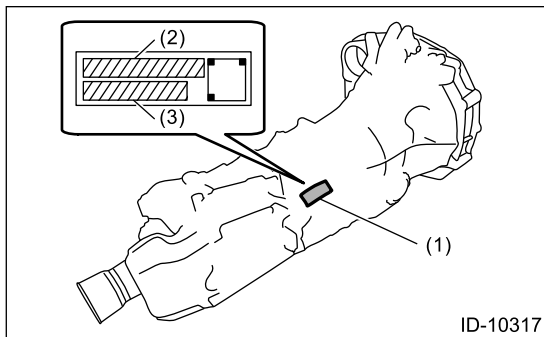

- (1) Label
- (2) MT type
- (3) Transmission serial No.

STI model

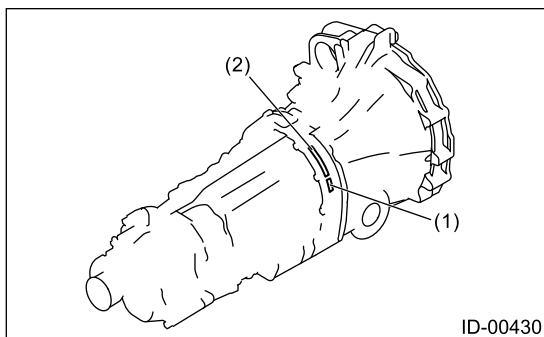

- (1) Transmission serial No. label
- (2) MT type label

- **Rear differential**

T-type

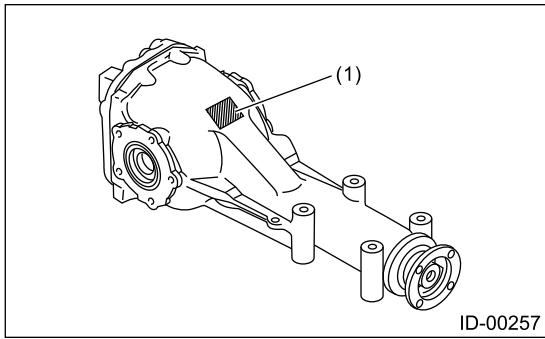

(1) Identification (white paint)

- **VB-type**

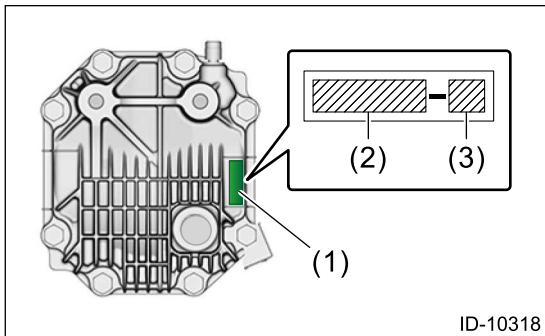

- (1) Label
- (2) Rear differential serial No.
- (3) Rear differential ID

- **FMVSS label**

For U4

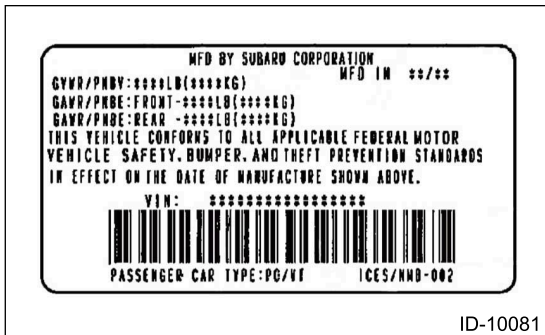

- **CMVSS label**

For C0

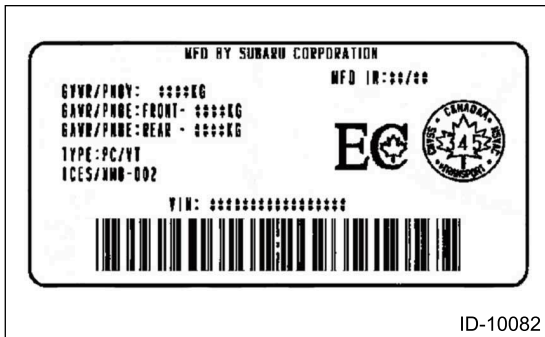

• **Model number label**

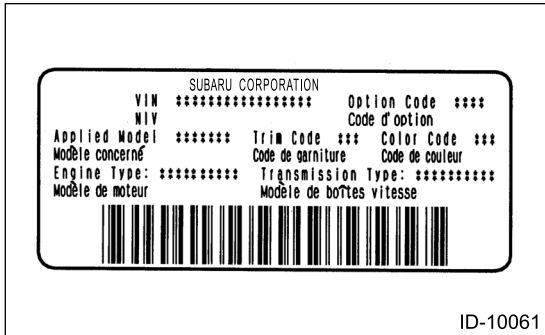

2. MEANING OF V.I.N.

The meaning of the V.I.N. is as follows:

JF1VA1A6XM8800001[

The starting and ending brackets () [] are stop marks.

Digits	Code	Meaning	Details
1 – 3	JF1	Manufacturer body area	JF1: Passenger car, SUBARU CORPORATION made
4	V	Car line	V: WRX
5	A	Body type	A: Sedan
6	1	Displacement class	1: 2.0 L AWD DI turbo 4-CYLINDERS GASOLINE 268HP 2: 2.5 L AWD high power turbo 4-CYLINDERS GASOLINE 310HP
7	A	Grade	A: WRX base, WRX base + L B: WRX premium + L + keyless Access + RECARO + BILSTEIN C: WRX premium + L + keyless Access + Moon Roof D: WRX premium + L + keyless Access + Blind Spot Detection + Moon Roof E: STI base + W + Keyless Access F: WRX premium + L + EyeSight + keyless Access + Moon Roof G: WRX premium + L + EyeSight + keyless Access + Blind Spot Detection + Moon Roof H: WRX limited + L + keyless Access + Moon Roof J: WRX limited + L + keyless Access + Blind Spot Detection + Harman/Kardon & Navi + Moon Roof K: WRX limited + L + keyless Access + Blind Spot Detection + Harman/Kardon + Moon Roof L: WRX limited + L + keyless Access + RECARO + Blind Spot Detection + Harman/Kardon + Moon Roof M: WRX limited + L + keyless Access + RECARO + Blind Spot Detection + Harman/Kardon & Navi + Moon Roof N: WRX limited + L + EyeSight + keyless Access + Moon Roof P: WRX limited + L + EyeSight + keyless Access + Blind Spot Detection + Harman/Kardon&Navi + Moon Roof R: STI base

Digits	Code	Meaning	Details
			<p>S: STI base performance + W + keyless Access + RECARO + BILSTEIN, STI base performance + W + keyless Access + RECARO</p> <p>T: STI limited + L + keyless Access + RECARO + Blind Spot Detection + Harman/Kardon&Navi + Moon Roof + BILSTEIN, STI limited + L + keyless Access + RECARO + Blind Spot Detection + Harman/Kardon&Navi+ Moon Roof</p> <p>U: STI limited + W+ keyless Access + Blind Spot Detection + Moon Roof</p> <p>V: STI limited + W + keyless Access + RECARO + Blind Spot Detection + Harman/Kardon + Moon Roof</p> <p>W: STI limited + W + keyless Access + RECARO + Blind Spot Detection + Harman/Kardon&Navi + Moon Roof + BILSTEIN, STI limited + W + keyless Access + RECARO + Blind Spot Detection + Harman/Kardon&Navi + Moon Roof</p> <p>Z: WRX limited + L + keyless Access + Blind Spot Detection + Harman/Kardon&Navi + Moon Roof + BREMBO</p>
8	6	Restraint	6: Manual belts, dual airbag, side airbag for seat back, curtain airbag for roof and driver's knee airbag
9	X	Check digit	X or 0 — 9
10	M	Model year	M: 2021MY
11	8	Transmission type & production site	8: Full-time AWD CVT (main plant, Gunma) 9: Full-time AWD 6 speed MT (main plant, Gunma)
12 — 17	800001	Serial number	800001 — 999999

3. MODEL NUMBER LABEL

The model number label indicates: the applied model, the option code, the trim code, the engine type, the transmission type, and the exterior color code. This information is helpful when placing orders for parts.

VAGGYA6

Digits	Code	Meaning	Details
1	V	Series	V: WRX
2	A	Body type	A: Sedan
3	G	Total engine displacement / drive system	F: 2.5 L AWD high power turbo G: 2.0 L AWD DI turbo
4	G	Model year	G: 2021MY

Digits	Code	Meaning	Details
5	Y	Destination	Y: U.S., Canada
6	A	Grade	A: WRX base B: WRX base + L C: WRX Pre+L D: WRX Ltd+L E: STI base F: STI base + W G: STI Pfm+W H: STI Ltd+W L: WRX ES Ltd+L N: STI Ltd+L S: WRX ES Pre+L
7	6	Fuel feed system / transmission	6: DI turbo 6 speed MT AWD 8: DI turbo high torque CVT AWD H: MFI High power turbo 6 speed MT AWD

The engine and transmission type are as follows.

• **Engine**

EJ257XG3LB

Digits	Code	Meaning	Details
1 and 2	EJ	Engine type symbol	EJ: 4 cylinders
3 and 4	25	Displacement	25: 2.5 L
5	7	Fuel feed device	7: MFI - single scroll high power turbo
6	X	Exhaust regulations	X: North America (Tier 3/LEV III)
7	G	Mounted transmission	G: 6MT
8 – 10	3LB	Detailed specifications	Used when ordering parts. For details, refer to the parts catalog.

FA20FXZB3A

Digits	Code	Meaning	Details
1 and 2	FA	Engine type symbol	FA: 4 cylinders
3 and 4	20	Displacement	20: 2.0 L
5	F	Valve train/fuel supply system/steering	F: DOHC DIT (LH)
6	X	Exhaust regulations	X: North America (Tier 3/LEV III)
7	Z	Intake and exhaust system	Z: Intake AVCS, exhaust AVCS, TGV, EGR
8	B	Mounted transmission	B: 6MT H: CVT
9 and 10	3A	Detailed specifications	Used when ordering parts. For details, refer to the parts catalog.

• **Transmission**

1. **MT**

TY751VB6CA

Digits	Code	Meaning	Details
1	T	Transmission	T: Transmission
2	Y	Transmission system	Y: Full-time AWD MT center differential
3 and 4	75	Distance between gear center	75: Distance between main shaft and drive pinion is 75 mm (2.95 in)
5	1	Classification	1: 6MT

Digits	Code	Meaning	Details
6	V	Transmission specifications	V: Full-time AWD single range 6MT with viscous coupling center differential (without Auto Start Stop)
7	B	Mounted engine	B: 2.0 L DOHC turbo
8 – 10	6CA	Detailed specifications	Used when ordering parts. For details, refer to the parts catalog.

TY856UW6AB

Digits	Code	Meaning	Details
1	T	Transmission	T: Transmission
2	Y	Transmission system	Y: Full-time AWD MT center differential
3 and 4	85	Distance between gear center	85: Distance between main shaft and drive pinion is 85 mm (3.35 in)
5	6	Classification	6: 6MT
6	U	Transmission specifications	U: Full-time AWD single range 6MT with driver's control center differential
7	W	Mounted engine	W: 2.5 L DOHC turbo
8 – 10	6AB	Detailed specifications	Used when ordering parts. For details, refer to the parts catalog.

2. CVT

TR690GB6BA

Digits	Code	Meaning	Details
1	T	Transmission	T: Transmission
2	R	Transmission system	R: Full-time AWD CVT
3 and 4	69	Distance between pulley centers	69: Distance between pulley centers is 169 mm (6.65 in)
5	0	Classification	0: CVT
6	G	Transmission specifications	G: Without Auto Start Stop, with CVTF cooler (with warmer feature), without CVTF cooler (air cooler)
7	B	Mounted engine	B: 2.0 L DOHC turbo
8 – 10	6BA	Detailed specifications	Used when ordering parts. For details, refer to the parts catalog.

• Rear differential

Identification	Reduction gear ratio	LSD
E2	4.111	None
E3	3.900	None
H5	3.545	Torsen

- **Option code**

HC

- 1-digit number

OP code	H	K	L	M	N	O	T	U	W	Y
Genuine leather seat	—	—	—	—	○	○	—	○	—	—
RECARO seat	○	—	—	○	—	—	○	—	○	○
Cold weather package	○	○	○	○	○	—	○	○	○	○
Safety view package	—	—	—	—	—	○	○	—	—	—
Advanced package	○	—	○	○	○	○	○	—	—	—
Performance damper	○	—	—	—	—	—	—	—	○	—

OP code 6 is a code for special edition.

- 2-digit number

OP code	C	D	E	F	G	J	K
Base audio	○	○	—	—	—	—	—
High audio	—	—	○	—	○	—	○
NAVI	—	—	—	○	—	○	—
Harman/Kardon speaker system	—	—	○	○	—	○	—
Sunroof	—	○	○	○	○	○	—
Performance brake package	—	—	—	—	—	○	—

OP code 5, 6 and 7 are codes for special edition.

4. IMMOBILIZER REGISTRATION TYPE

- **Model without keyless access with push button start**

Refer to "Type B" described in "REGISTRATION MANUAL FOR IMMOBILIZER".

- **Model with keyless access with push button start**

Refer to "Type D" described in "REGISTRATION MANUAL FOR IMMOBILIZER".

RECOMMENDED MATERIALS

RM

1. Recommended Materials

RECOMMENDED MATERIALS

1. GENERAL



To insure the best performance, always use the specified oil, gasoline, adhesive, sealant, etc. or a substitute of equivalent quality.

2. FUEL

- Use unleaded gasoline because using leaded gasoline may cause a malfunction.
- Do not use the low quality gasoline, or improper fuel such as diesel fuel, fuel alcohol, or gasoline additive because they will adversely affect on engine components and fuel system components.
- Always use gasoline that is equivalent to that prescribed in the owner’s manual or that of high octane value. There is the possibility of damaging or improper operation of the engine and fuel injection system if the specifications are not observed. Use the prescribed gasoline type to maintain proper vehicle performance.

3. LUBRICANT

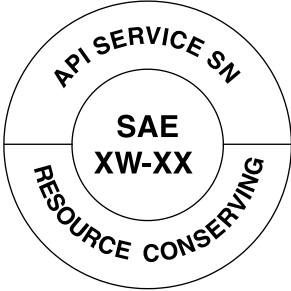
Use the lubricants shown in the table below, or equivalent. See the table below to choose the correct SAE viscosity.

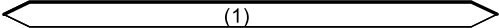
Item	Recommended materials																	
	Engine oil standard																	
Engine oil Choose oil suitable for the standard from the right.	 <p style="text-align: center;">RM-00081</p> <p style="text-align: center;">Those with SN or SN PLUS “Resource Conserving” logo in case of API standard.</p>	<p style="text-align: center;">or</p>  <p style="text-align: center;">RM-00002</p> <p style="text-align: center;">Those with GF-5 “starburst mark” displayed on top of the container in case of ILSAC standard.</p>																
SAE viscosity No. and applicable temperature																		
<table style="margin-left: auto; margin-right: auto;"> <tr> <td style="border-top: 1px solid black; border-bottom: 1px solid black;">(°C)</td> <td style="border-top: 1px solid black; border-bottom: 1px solid black;">-30</td> <td style="border-top: 1px solid black; border-bottom: 1px solid black;">-20</td> <td style="border-top: 1px solid black; border-bottom: 1px solid black;">-15</td> <td style="border-top: 1px solid black; border-bottom: 1px solid black;">0</td> <td style="border-top: 1px solid black; border-bottom: 1px solid black;">15</td> <td style="border-top: 1px solid black; border-bottom: 1px solid black;">30</td> <td style="border-top: 1px solid black; border-bottom: 1px solid black;">40</td> </tr> <tr> <td style="border-top: 1px solid black; border-bottom: 1px solid black;">(°F)</td> <td style="border-top: 1px solid black; border-bottom: 1px solid black;">-22</td> <td style="border-top: 1px solid black; border-bottom: 1px solid black;">-4</td> <td style="border-top: 1px solid black; border-bottom: 1px solid black;">5</td> <td style="border-top: 1px solid black; border-bottom: 1px solid black;">32</td> <td style="border-top: 1px solid black; border-bottom: 1px solid black;">59</td> <td style="border-top: 1px solid black; border-bottom: 1px solid black;">86</td> <td style="border-top: 1px solid black; border-bottom: 1px solid black;">104</td> </tr> </table> <div style="text-align: center; margin-top: 20px;">  </div> <p style="text-align: right; margin-top: 20px;">RM-00082</p> <p style="text-align: center; margin-top: 20px;">(1) 5W-30 (synthetic oil) Specified</p>			(°C)	-30	-20	-15	0	15	30	40	(°F)	-22	-4	5	32	59	86	104
(°C)	-30	-20	-15	0	15	30	40											
(°F)	-22	-4	5	32	59	86	104											

Item	Recommended materials														
	API standard														
Manual transmission gear oil (TY85)* ¹ and rear differential gear oil* ²	GL-5														
SAE viscosity No. and applicable temperature															
<table border="1"> <tr> <td>(°C)</td> <td>-30</td> <td>-15</td> <td>0</td> <td>15</td> <td>30</td> <td>40</td> </tr> <tr> <td>(°F)</td> <td>-22</td> <td>5</td> <td>32</td> <td>59</td> <td>86</td> <td>104</td> </tr> </table> <p style="text-align: right;">RM-00084</p> <p>(1) 75W-90 (recommended) (2) 90</p>		(°C)	-30	-15	0	15	30	40	(°F)	-22	5	32	59	86	104
(°C)	-30	-15	0	15	30	40									
(°F)	-22	5	32	59	86	104									

*1

Caution:

Applicable to TY85 only.

*2

Caution:

Do not mix two different kinds or makes of gear oil.

Caution:

If an alternative transmission gear oil (TY75) is used, expected functionality and performance may not be obtained.

Item	Recommended materials	Item number	Alternative
Transmission gear oil (TY75)	SUBARU GEAR OIL EXTRA MT	—	GL-5 (75W-90)
CVT front differential gear oil	SUBARU GEAR OIL EXTRA MT	—	GL-5 (75W-90)

4. FLUID

Use the fluids specified in the table below. Do not mix two different kinds or makes of fluid.

Caution:

Be sure to use the recommended CVTF. Using material except recommended one would cause trouble.

Item	Recommended materials	Item number	Alternative
Transmission fluid	Subaru High Torque CVT Fluid	K0421Y0700	—
Power steering fluid	SUBARU ATF	K0410Y0700	DEXRON III

Item	Recommended materials	Item number	Alternative
Brake fluid and clutch fluid	FMVSS No. 116 DOT3, or DOT4	—	—

5. ENGINE COOLANT

Use genuine engine coolant to protect the engine.

Item	Recommended materials	Item number	Alternative
Engine coolant	SUBARU SUPER COOLANT (Concentrated type)	—	—
	SUBARU SUPER COOLANT (Diluted type)	K0670Y0001	—
Water for dilution	Distilled water	—	Soft water or tap water
Cooling system protective agent	Cooling system conditioner	SOA345001	—

6. REFRIGERANT

The standard air conditioner installed on this vehicle uses HFO-1234yf refrigerant. Do not mix it with other refrigerants. Also, do not use any air compressor oil except for VC200YF.

Item	Recommended materials	Item number	Alternative
Refrigerant	HFO-1234yf	—	—
Compressor oil	VC200YF	—	—

7. GREASE

Use grease and supplementary lubricants shown in the table below.

Item	Application point	Application point	Recommended materials (Item number)	Alternative
Supplementary lubricants	Exhaust	Oxygen sensor	Spray type lubricant (004301003)	—
Grease	MT	MT main shaft (spline parts)	NICHIMOLY N-130	—
		MT main shaft (oil seal lip)		
		Transfer driven gear (front roller bearing, rear roller bearing) (TY75)		
		Clutch operating cylinder		
		Release bearing (inner circumference)		

Item	Application point	Application point	Recommended materials (Item number)	Alternative		
		Release bearing (contact surface of release bearing guide) (STI model)				
		Release lever shaft (STI model)				
		Clutch release lever (contact surface of release bearing, contact surface of operating cylinder) (STI model)				
		Clutch release lever (contact surface of release bearing, contact surface (dented portion) of pivot, contact surface (dented portion) of operating cylinder, contact surface of transmission case) (except for STI model)				
		Clutch master cylinder push rod			SILICONE GREASE G-40M	—
		Gear shift lever (cable type)			Multemp HL-D	—
		Gear shift lever (rod type)			NIGTIGHT LTS No. 2 grease	—
Clutch pedal						
Brake	Brake pedal					
CVT	Select lever		Multemp D No. 2	—		
Door	Door latch		SILICONE GREASE G-30M	—		
	Door striker		(004404002)			
Steering	Steering gearbox (hydraulic power steering)		One-Luber SG	—		
	Steering gearbox (electric power steering) (rack and pinion)		Molywhite LS-G	—		
	Steering gearbox (electric power steering) (boot and tie-rod installation parts)		One-Luber 2128	—		
Brake	Disc brake (lock pin, guide pin, piston boot)		NIGLUBE RX-2 (000041000)	—		
	Between brake pad and shim		Molykote AS-880N (K0777YA010)	—		
	Brake pad clip		Molykote M7439	—		
	Parking brake		Molykote 44MA	—		
Drive shaft	Front drive shaft (except for STI model)		NKG302	—		
	Rear drive shaft		NKG814	—		
	Front drive shaft (STI model)		One-Luber GKN-C	—		
Seat frame	Seat belt inner - front installation area		APOLLOIL AUTOLEX A	Lithium soap grease (not		

Item	Application point	Application point	Recommended materials (Item number)	Alternative
				containing silicone) Base oil: Not specified Consistency: NLGI No. 2

8. ADHESIVE

Use the adhesives shown in the table below, or equivalent.

Item	Application point	Application point	Recommended materials	Alternative
Adhesive	Glass and body	Windshield glass, rear window glass, and body	<ul style="list-style-type: none"> Dow Automotive's adhesive: ESSEX U-400HV or the equivalent Glass primer: U-401 and U-402 Painted surface primer: U-413 	—

9. SEAL MATERIAL

Use the seal material shown in the table below, or an alternative.

Item	Application point	Application point	Recommended materials (Item number)	Alternative (Item number)	
Seal material	Engine	FA/EJ	Engine oil pressure switch	THREE BOND 1324 (004403042)	—
			PCV valve		
		FA/EJ	Engine oil pan	THREE BOND 1217G (K0877Y0100) THREE BOND 1217H	—
			Separator cover		
			Cylinder block		
			Rocker cover		
			Cylinder head		
			FA		
		Oil pan upper			
		Camshaft carrier			

Item	Application point		Application point	Recommended materials (Item number)	Alternative (Item number)	
			Cylinder head gasket			
			Scavenge pump			
			Front camshaft cap			
			Rear camshaft cap			
			High-pressure fuel pump case			
			Main gallery plug	THREE BOND 1105 (004403010)	—	
	EJ		Camshaft cap	THREE BOND 1217G (K0877Y0100)	—	
			Oil pump	THREE BOND 1217H		
			Oil return cover bolt (when reusing bolts)	THREE BOND 1324 (004403042)	—	
			Engine oil separator cover mounting bolt (when reusing bolts)			
			Engine oil pump mounting bolt (when reusing bolts)			
			Timing belt guide cam sprocket side mounting bolt (when reusing bolts)			
			Service hole plug			
				Intake manifold nipple	THREE BOND 1105 (004403010)	—
		MT	TY75/TY85	MT transmission case	THREE BOND 1215B	THREE BOND 1215 (004403007)
MT transfer case						
TY75	Transmission cover					
TY85	Transmission oil pan					
	Clutch housing					
CVT		CVT transmission case	THREE BOND 1217B (K0877YA020)	—		
		Converter case				
		CVT converter case cover				
		CVT oil pump chain cover				
		CVT drive pinion retainer				
		Transmission oil pan				
Steering	Hydraulic	Steering adjusting screw	THREE BOND 1102	—		

Item	Application point		Application point	Recommended materials (Item number)	Alternative (Item number)
				(004403006)	
		Electric		SEAL END No. 22	—
	Door	Front	Sealing cover	3M Butyl Tape 8626	—
		Rear			
Seal material	Rear differential	T-type/V B3-type	Drive pinion shaft and self-locking nut (seating face)	THREE BOND 1324 (004403042)	—
		T-type	Hypoid driven gear bolt		
			Filler plug, drain plug	THREE BOND 1105 (004403010)	—
			Side retainer bolt	THREE BOND 1110F	THREE BOND 1110B

PRE-DELIVERY INSPECTION

PI

1. Pre-delivery Inspection

PRE-DELIVERY INSPECTION

GENERAL DESCRIPTION

The purposes of the pre-delivery inspection (PDI) are as follows.

- Remove the vehicle protective parts for transportation.
- Check that the vehicle or parts before delivery are not damaged during transportation or storage.
- Check that the vehicle after repair is normal.
- Make sure to provide a complete vehicle to customer.

For above reasons, all SOA service center must carry out the PDIs before delivery of vehicle.

Besides, all SOA service center and PDI center check the condition of all vehicles to make sure to take responsibility.

PRE-DELIVERY INSPECTION

PRE-DELIVERY INSPECTION (PDI) PROCEDURE

Static checks just after vehicle receipt

Item	Check point
1. Appearance	<ol style="list-style-type: none">1. If the vehicle is covered with protective film, visually check the vehicle body for damage and dents. If the protective film has been removed, visually check the painted body surfaces in detail for damage or rust.2. Visually check the glass and light lenses for any damage, cracks or excessive gaps between body panels.3. Visually check the plated parts for any damage.4. Check the instrument panel, console and trim for stains or dirt.
2. Tire	<ol style="list-style-type: none">1. Check the tires for damage, defective, and dents on wheels.2. Check the tire air pressure.
3. Fuses	If the vehicle is about to be delivered to customer, attach a back-up fuse.
4. Lock/unlock and open/close operation of doors	<ol style="list-style-type: none">1. Using the key, check the door can be locked or unlocked normally.2. Open and close all doors to check that there are no defective.3. Operate the power door lock switch to check that all doors lock and unlock normally.
5. Child safety lock	Check the child safety lock system operates normally.
6. Trunk lid open/close operations	<ol style="list-style-type: none">1. Operate the trunk opener button to check that the trunk lid opens normally.2. Open and close the trunk lid to see that there are no abnormal conditions.
7. Operation check of trunk lid release lever	Operate the trunk lid release lever to check that the trunk lock is unlocked normally.

Item	Check point
8. Fuel lid opener lever	Operate the fuel lid opener to check that the fuel lid is unlocked normally.
9. Towing hook (eyebolt)	At factory shipment, the towing hook (eyebolt) is installed to the rear bumper. Remove the towing hook (eyebolt), store it in the holder.
10. Accessory	<p>Check that the following accessories are provided.</p> <ul style="list-style-type: none"> • Owner's manual • Warranty booklet • Maintenance note • Spare key • Key number plate • Jack • Jack handle • Tool set • Spare tire • Towing hook (eyebolt)
11. Front hood lock release system	Operate the front hood lock release lever to check that the front hood opens normally.
12. Battery	Check the battery for any abnormal conditions such as rust or traces of battery fluid leaks.
13. Brake fluid	Check the brake fluid amount.
14. Engine oil	Check the engine oil amount.
15. CVTF	Check for leakage of CVTF.
16. Transmission gear oil	<ul style="list-style-type: none"> • Check that the transmission gear oil level is normal. (Except for STI model) • Check for leakage of the transmission gear oil. (STI model)
17. CVT front differential gear oil	Check for no leakage of CVT front differential gear oil.
18. Rear differential gear oil	Check for leakage of gear oil from the rear differential.
19. Engine coolant	Check the engine coolant level.
20. Clutch fluid	Check the clutch fluid amount.
21. Window washer fluid	Check the window washer fluid amount.
22. Front hood latch	Check that the front hood is closed normally and locked securely.
23. Keyless entry system	Check that the keyless entry system operates normally.
24. Keyless access system	Check that the keyless access system operates normally.
25. Alarm system	Check that the alarm system operates normally.
26. Seat	<ol style="list-style-type: none"> 1. Check the seat surfaces for stains or dirt. 2. Check the seat installation conditions and functionality.
27. Seat belt	<ol style="list-style-type: none"> 1. Check the seat belt installation conditions and functionality. 2. Check the seat belt warning system operates normally.

Item	Check point
28. TPMS (U.S. model)	If the display of TPMS warning light does not operate normally, perform the diagnosis by referring to TPMS (Diagnosis).
29. Grommet installation	Install the grommet provided in the rear seat to the tie-down hole.

Checks with the engine running

Item	Check point
30. Delivery (test) mode	Turn the ignition switch to ON and check that the malfunction indicator light starts blinking.
31. Immobilizer system	<ol style="list-style-type: none"> 1. Check that the engine starts with all keys that are equipped on vehicle. 2. Check that the security indicator light operates normally.
32. Push button start	Using the push button start function of the access key equipped with the vehicle, check that the engine starts and stops.
33. Starting condition	Start the engine and check that the engine starts smoothly.
34. Exhaust system	Check that the exhaust noise is normal and no leaks are found.
35. Indicator and warning lights	Check that all indicator lights and warning lights are operating correctly.
36. Heater & ventilation	Check that the heater & ventilation system operates normally.
37. Air conditioner	Check that the air conditioner operates normally.
38. Multi-function display (MFD)	Check that the Multi-Function Display (MFD) function operates normally.
39. Audio	Check that all audio functions operate normally.
40. Navigation system	<ol style="list-style-type: none"> 1. Check all display functions for normal operation. 2. Check that the navigation, audio and AUX systems operate normally. 3. Check that the rearview camera operates normally.
41. Telematics system	Check that the indicator light on the overhead console or on the stereo camera cover assembly goes off.
42. Accessory power supply socket	Check that the accessory power supply socket operates normally.
43. Lighting system	Check that the lighting system operates normally.
44. Wiper deicer	Check that the wiper deicer operates normally.
45. Illumination control	Check that the illumination control operates normally.
46. Window washer system	Check that the window washer system operates normally.
47. Wiper system	Check that the wiper system operates normally.
48. Power window	Check that the power window operates normally.
49. Sunroof	Check that the sunroof operates normally.

Item	Check point
50. Rear defogger system	Check that the rear defogger system operates normally.
51. Door mirror	Check that the mirror heater and remote control mirror operate normally.
52. Parking brake	Check that the parking brake operates normally.
53. Blind Spot Detection / Rear Cross Traffic Alert (BSD/RCTA)	<ol style="list-style-type: none"> 1. Press the BSD/RCTA OFF switch several times to check that the system is activated and deactivated correctly. 2. Check the rear bumper around the sensor for dirt, scratch, affixed stickers and poor paint coating.
54. Reverse Automatic Braking (RAB)	<ol style="list-style-type: none"> 1. Check that the RAB system is activated and deactivated correctly. 2. Check the sonar sensor installed on the rear bumper for parts missing, dirt, scratch, foreign objects, etc.
55. Diagnostic trouble code (DTC) check	Check that the diagnostic trouble code (DTC) is not detected.
56. EyeSight assist monitor	Check that the EyeSight assist monitor operates normally.
57. Auto vehicle hold (AVH) system	Check that the AVH system is activated and deactivated correctly.
58. Front view monitor	Check that the front view monitor operates normally.

Dynamic test with the vehicle running

Item	Check point
59. Brake test	Check the foot brake for normal operations.
60. Shift control	Check that the MT, CVT shifts normally.
61. Cruise control	Check that the cruise control system operates normally.
62. Subaru EyeSight	Check that the Subaru EyeSight operates normally.

Checks after dynamic test

Item	Check point
63. Power steering fluid (hydraulic power steering model)	Check that the power steering fluid level is normal.
64. Power steering system (electric power steering model)	Check the steering warning light operation.
65. Fluid leakage	Check for fluid/oil leaks.
66. Water leakage	Spray the vehicle with water and check for water leaks.
67. Appearance 2	<ol style="list-style-type: none"> 1. Remove the protective film. (If attached) 2. Check the body paints for damage and stain. 3. Check the plated parts for damage and rust.

1. APPEARANCE

- If the vehicle is covered with protective film, visually check the vehicle body for damage and dents.
- If the protective film has been removed, visually check the body painted area for damage or rust in detail and repair as necessary.

- Visually check the windshield glass, door glasses and light lenses for any damage, cracks or excessive gaps to the body panel and replace as necessary.
- Visually check the plated parts, such as the grilles and door knobs, for damage or loss of gloss and replace the parts as necessary.
- Check the instrument panel, console and trim for stains or dirt.
- Check the keyless key or access key for dirt, and wipe off if necessary.

2. TIRE

- Check the tires for damage, defective, and dents on wheels.
- Check and correct the tire size, spare tire and tire air pressure described on the tire air pressure label (driver's side).

3. FUSE

Fuses for the back-up circuit on initially delivered vehicles are removed to prevent battery discharge. Attach the 20 A fuse as shown in the figure.

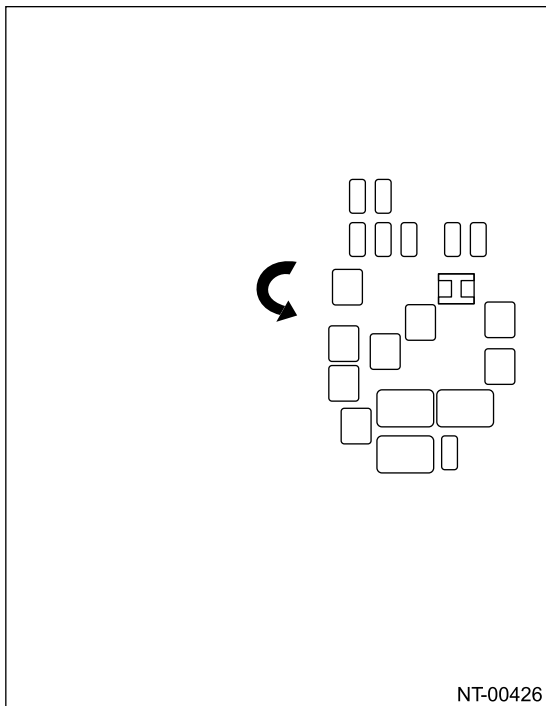

4. LOCK/UNLOCK AND OPEN/CLOSE OPERATION OF DOORS

1. Using the key, lock and unlock the door several times to check for normal operation. Open and close the door several times for smooth movement.

- 2.** Completely close the driver's door, and then check the smooth movement with operating door lock knob from lock to unlock several times. Set the door lock knob (A) to lock position. Then pull the inner remote (B) to ensure that doors will not open. For other doors, place the door lock knob (A) to lock position and then pull the inner remote (B) to ensure that doors will not open.

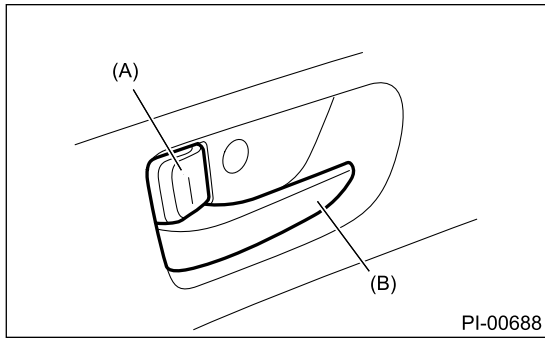

- (A) Door lock knob
(B) Inner remote

- 3.** Close all the doors, and then press the lock on power door lock switch at driver's side. Check that all doors lock.
- 4.** Press the driver's side power door lock switch to unlock side. Check that all doors are unlocked.

5. Check that the passenger's power door lock switch locks and unlocks normally in the same manner.

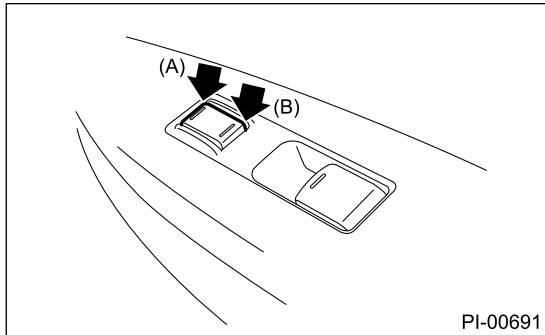

- (A) Lock
(B) Unlock

6. With ACC ON or IGN ON, open the driver's door. Press lock on power door lock. Check that the door is not locked.

5. CHILD SAFETY LOCK SYSTEM

1. Set the child safety lock on both rear doors to the lock position.
2. Close the rear doors completely.
3. Check that the lock levers of the rear doors are in the unlock position. Then, pull inner remote of rear doors to ensure that the doors will not open.

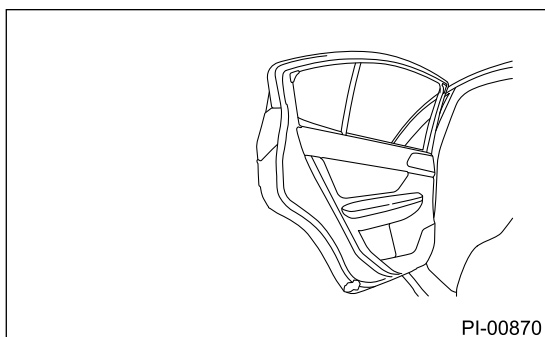

- (A) Unlock
(B) Lock

4. Pull the outer handles of rear doors to ensure that the doors will open.

6. TRUNK LID OPEN/CLOSE OPERATIONS

1. Operate the trunk opener button to check that the trunk lid opens.
2. Open and close the trunk lid several times for smooth movement.

7. OPERATION CHECK OF TRUNK LID RELEASE HANDLE

Caution:

Do not check the trunk lid release handle when in the trunk. If the trunk lid release handle is defective, you may be trapped in.

1. Use a flat tip screwdriver. Slide the screwdriver blade from the slit aperture of the lock assembly fully to the end until you hear a click. This places the latch in the locked position.

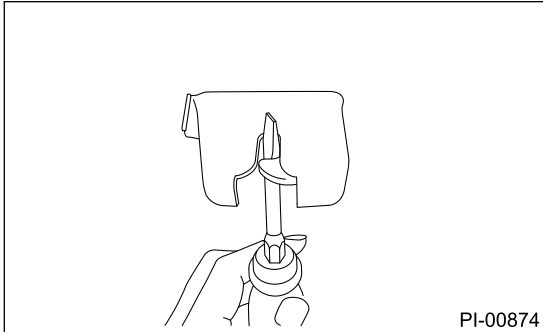

2. Make sure the latch is released by pulling the yellow trunk lid release handle in the direction of arrow.

8. FUEL LID OPENER LEVER

Operate the fuel lid opener to check that the fuel lid is unlocked normally. Check that the filler cap is securely closed.

9. TOWING HOOK (EYEBOLT)

Note:

At factory shipment, the towing hook (eyebolt) is installed to the rear bumper for securing the vehicle during transportation. Follow the procedure below to store the towing hook (eyebolt) to the holder in the spare tire.

1. Remove the towing hook (eyebolt) from the rear bumper.

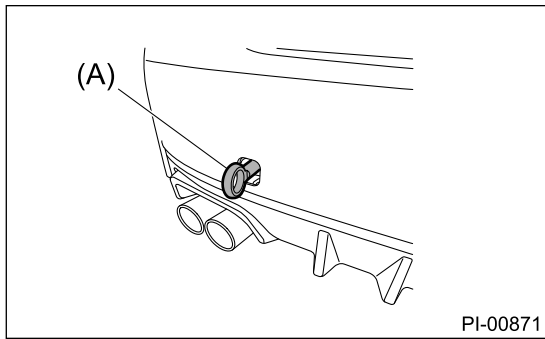

(A) Towing hook (eyebolt)

2. Store the towing hook (eyebolt) to the holder in the spare tire.

(A) Towing hook (eyebolt)

3. Install the supplied hook cover rear to the rear bumper.

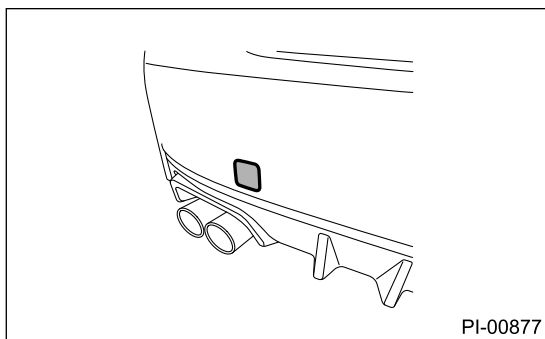

10. ACCESSORY

Check that the following accessories are provided.

- Owner's manual
- Warranty booklet
- Maintenance note
- Spare key
- Key number plate
- Jack
- Jack handle
- Tool set
- Spare tire
- Towing hook (eyebolt)

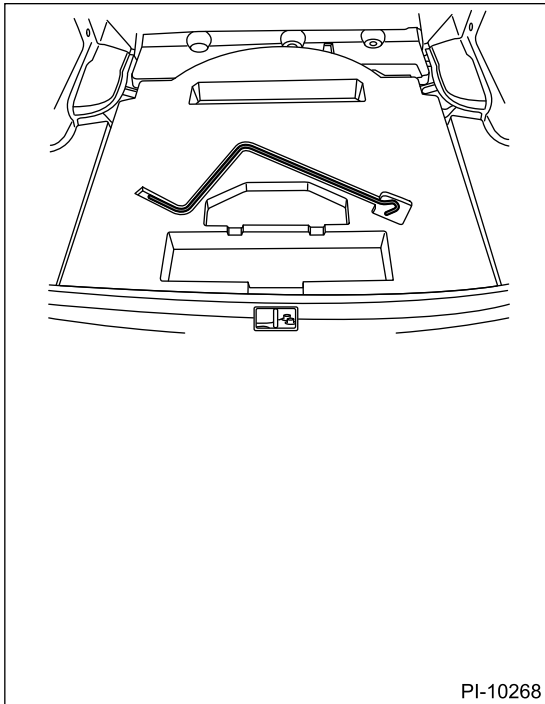

- (A) Jack handle
- (B) Spare tire
- (C) Jack
- (D) Towing hook (eyebolt)
- (E) Screwdriver
- (F) Wheel nut wrench

11. FRONT HOOD LOCK RELEASE SYSTEM

Operate the front hood lock release lever to check that the front hood is unlocked normally.

Operate the lever (A) and check that the front hood is opened normally. Check that the front hood can be supported by damper stay.

12. BATTERY

Check the battery terminals to make sure that there are no rust or corrosion due to fluid leaks. Check that the battery caps are securely tightened.

- (A) Cap
- (B) Upper level
- (C) Lower level

13. BRAKE FLUID

Caution:

- **If the brake fluid is spilt over exhaust pipe, wipe it off with cloth to avoid emitting smoke or causing a fire.**
- **Always check the level using the specified direction because there is a partition in the reservoir tank.**

Check that the brake fluid level is normal from a straight view or within 90° to the right and left forward. If the amount is insufficient, carry out a brake line test to identify brake fluid leaks and check the brake operation. After that, refill the brake fluid tank with the specified type of fluid.

- (A) MIN. level

(B) MAX. level

(C) Brake fluid

14. ENGINE OIL

Caution:

If the engine oil is spilt over exhaust pipe or the under cover, wipe it off with cloth to avoid emission of smoke or causing a fire.

1. Park the vehicle on a level surface.
2. Remove the oil level gauge and wipe away the oil.
3. Reinsert the oil level gauge all the way. Be sure that the oil level gauge is correctly inserted and properly orientated.
4. Pull out the oil level gauge again, and check both sides of the oil level gauge. Use a lower side to determine the engine oil level. If the engine oil level is below "L" line, add oil to bring the level up to "F" line.
5. Start the engine, and spread the oil in engine room.
6. After turning off the engine, wait for five minutes or more for the oil to return to the oil pan before checking the oil level.

Note:

To prevent overfilling of engine oil, do not add oil above "F" line when the engine is cold.

- Except for STI model

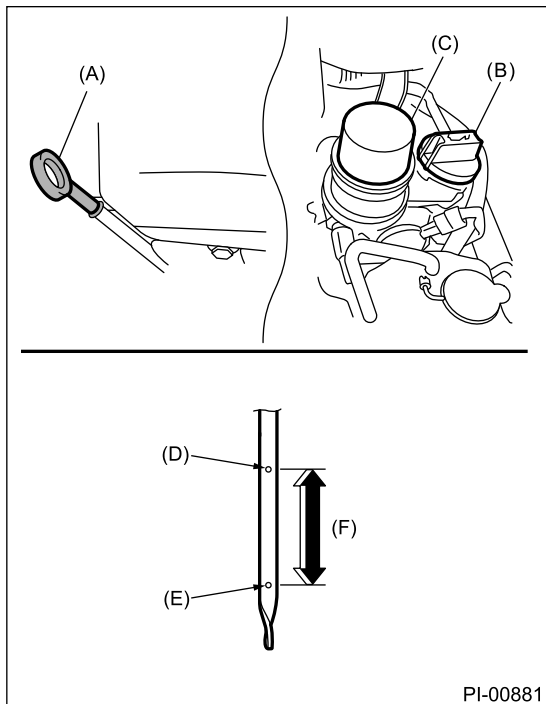

(A) Engine oil level gauge

(B) Engine oil filler cap

(C) Engine oil filter

(D) "F" line

(E) "L" line

(F) Approx. 1.0 L (1.1 US qt, 0.9 Imp qt)

- STI model

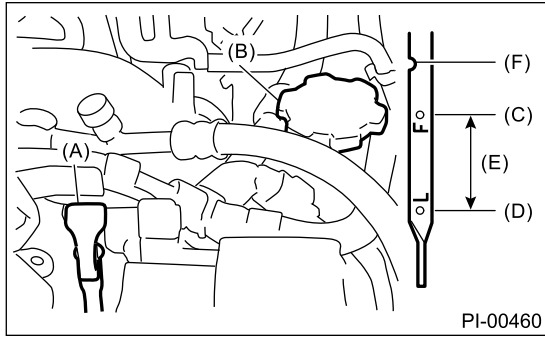

- (A) Engine oil level gauge
- (B) Engine oil filler cap
- (C) "F" line
- (D) "L" line
- (E) Approx. 1.0 L (1.1 US qt, 0.9 Imp qt)
- (F) Notch mark

15. CVTF

Caution:

If the CVTF is spilt over exhaust pipe, wipe it off completely with cloth to avoid emitting smoke or causing a fire.

Check for leakage of CVTF.

16. TRANSMISSION GEAR OIL

Caution:

If transmission gear oil is spilt over the exhaust pipe, wipe it off with a cloth to avoid emitting smoke or causing a fire.

Except for STI model

Check that the transmission gear oil level is normal. If the amount of gear oil is insufficient, check that no leaks are found. Then, add the necessary amount of specified transmission gear oil.

Refer to "6MT" section for transmission gear oil inspection.  [Ref. to MANUAL TRANSMISSION AND DIFFERENTIAL\(6MT\)\(TY75\)>Transmission Gear Oil>INSPECTION.](#)

STI model

Check for leakage of the transmission gear oil.

17. CVT FRONT DIFFERENTIAL GEAR OIL

Caution:

If gear oil is spilt over the exhaust pipe, wipe it off with a cloth to avoid emitting smoke or causing a fire.

Check for no leakage of CVT front differential gear oil.

18. REAR DIFFERENTIAL GEAR OIL

Caution:

If the rear differential gear oil is spilt over exhaust pipe, wipe it off with cloth to avoid emitting smoke or causing a fire.

Check for leakage of gear oil from the rear differential.

19. ENGINE COOLANT

Caution:

If the engine coolant is spilt over exhaust pipe, wipe it off with cloth to avoid emitting smoke or causing a fire.

Check that the engine coolant level on the reservoir tank is normal. If the amount of engine coolant is insufficient, check that no leaks are found. Then, add the necessary amount of coolant with the specified concentration.

20. CLUTCH FLUID

Caution:

- **If any clutch fluid is spilt on the exhaust pipe, wipe it off with a cloth to avoid emitting smoke or causing a fire.**
- **This reservoir tank has the brake fluid chamber and the clutch fluid chamber. When checking the fluid level, always check the fluid from the clutch fluid chamber side where the tank hose is connected.**

Check that the clutch fluid level is normal. If the amount of fluid is insufficient, check that no leaks are found. Then, add the necessary amount of specified fluid.

(A) Clutch fluid chamber

(B) MAX. level

(C) MIN. level

21. WINDOW WASHER FLUID

Check that the window washer fluid level is normal. If the amount of washer fluid is insufficient, check that no leaks are found. Then, add the necessary amount of washer fluid.

Note:

If there is the vibration, water comes into the layer of air in the washer tank and the water level may drop. This is not a malfunction.

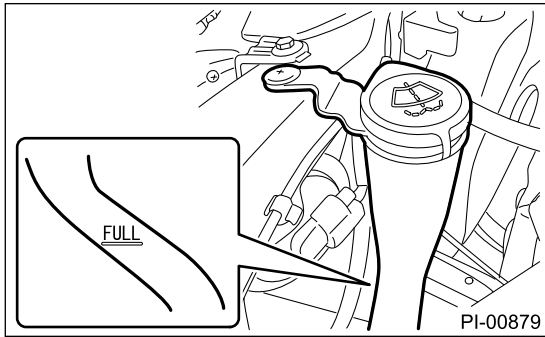

22. FRONT HOOD LATCH

Close the front hood. Check that the front hood is securely latched.

23. KEYLESS ENTRY SYSTEM

Check the keyless entry system operations as follows:

- Fully open all the door windows.
- Remove the key from ignition switch, and then close all doors.
- Press the "LOCK" button momentarily. Check that all the doors become locked, the buzzer sounds once, and the hazard lights flash once.

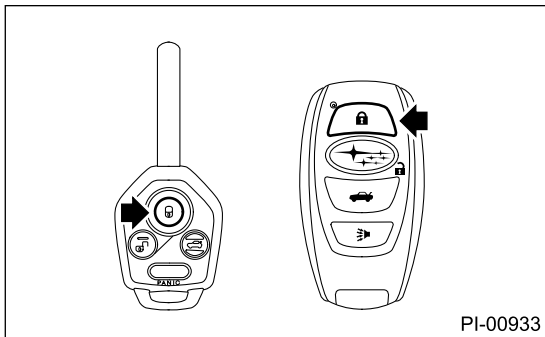

- Press the "UNLOCK" button momentarily. Check that the driver's door is unlocked, the buzzer sounds twice, and the hazard lights flash twice.

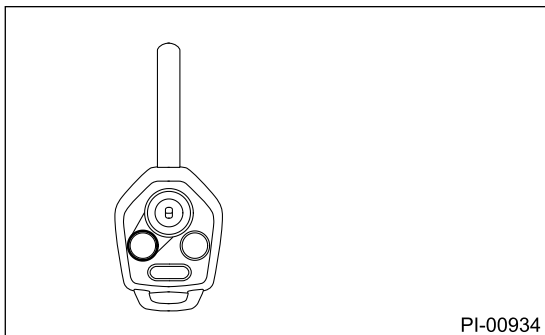

- Within 5 seconds, press the "UNLOCK" button momentarily. Check that all doors are unlocked, the buzzer sounds twice, and the hazard lights flash twice.
- Check that the buzzer sounds twice, and the hazard lights flash twice, when the trunk lid unlock button is held down to unlock the trunk lid.

- Press the "PANIC" button. Check that the panic mode (the horn keeps sounding, hazard light flashes) is initiated. Also, check that this condition continues for 30 seconds or until when any of the buttons on the key are pressed.

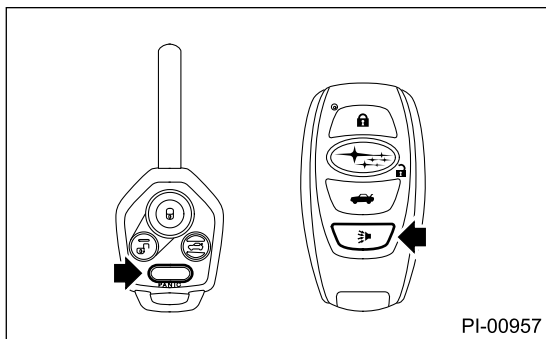

- Press the "LOCK" button momentarily with one of the doors opened. Check that the buzzer sounds 5 times, and the hazard light flashes 5 times to notify the door not being fully closed. Then, close all doors. Check if all doors are locked and buzzer sounds once and the hazard light flashes once.
- With one of the doors open, press the "LOCK" side of the power door lock switch. Then, close all doors. Check if all doors are locked and buzzer sounds once and the hazard light flashes once.
 - Driver's side

- Passenger's side

Check keyless answer-back buzzer operation

- The system uses the buzzer and sounds the keyless answer-back buzzer when the door is locked or unlocked. The keyless answer-back buzzer can be turned OFF. To turn the keyless answer-back buzzer from ON to OFF, close all doors, (with the key not inserted into the key cylinder), hold down the "UNLOCK" side of the power door lock switch and insert the key into the key cylinder. Within 10 seconds, insert and take out the key for 5 times or more, and within 10 seconds after that, open and close the driver's door. With the door closed, the hazard light will flash 3 times, indicating that the keyless answer-back buzzer has been turned OFF. To turn the keyless answer-back buzzer from OFF to ON, perform this procedure again. The hazard light will flash 3 times, indicating that the keyless answer-back buzzer has been turned ON.

24. KEYLESS ACCESS SYSTEM

Caution:

- **When performing the check, check one access key at a time, separating individual keys.**
- **Do not leave any separated access keys in the vehicle.**
- **Fully open all the door windows.**

Note:

The following inspections show the initial settings. When the settings are different from the initial settings, use Subaru Select Monitor to check the details of each setting for inspections.

 **Ref. to BODY CONTROL SYSTEM (DIAGNOSTICS)>Read Current Data>OPERATION.**

- While carrying the access key, check that the room light illuminates when you move close to the front door handles of the vehicle whose doors are all locked.
- While carrying the access key, check that the driver's door is unlocked, the buzzer sounds, and the hazard light blinks by grasping the front door knob (touching the touch sensor on the driver's side (unlock)).
- While carrying the access key, check that all doors are unlocked, the buzzer sounds, and the hazard light blinks by grasping the front door knob (touching the touch sensor on the passenger's side (unlock)).
- While carrying the access key, check that all doors are locked, the buzzer sounds, and the hazard light blinks by touching the touch sensor (lock) of the front door.

Note:

- **The hazard lights flash twice and the buzzer sounds twice when unlocking.**
- **The hazard lights flash once and the buzzer sounds once when locking.**

(A) Touch sensor (lock)

- Check that the trunk unlocks, the hazard lights flash twice, and the buzzer sounds twice when the trunk opener button is pressed while carrying the access key.

(A) Trunk opener button

- Manually operate the access key button to check the lock/unlock of doors, and the flashing of hazard lights.
- Check the mechanical key attached to the access key can be used for locking/unlocking.

Caution:

The mechanical key is a single groove type. Insert the mechanical key with the groove side facing the front side of the vehicle.

(A) Mechanical key

- With the access key in the vehicle, check that warning buzzer sounds and locking does not occur when you touch the touch sensor on the door (lock).

Caution:

Remove the mechanical key from the access key and hold the mechanical key.

- With the access key in the trunk, check that the warning buzzer sounds and the trunk unlocks when you press the trunk opener button.

25. ALARM SYSTEM

Note:

The following inspections show the initial settings. When the settings are different from the initial settings, use Subaru Select Monitor to check the details of each setting for inspections.

 [Ref. to BODY CONTROL SYSTEM \(DIAGNOSTICS\)>Registration Body Integrated Unit>OPERATION.](#)

1. Fully open all the door windows.
2. Remove the key from ignition switch, and then close all doors, trunk and front hood.
3. Press the "LOCK" button momentarily on the keyless transmitter or the access key. All doors are locked and the security indicator light flashes quickly for 30 seconds (5 flashes in 2 seconds). After that, it flashes slowly (2 times in 2 seconds), and the alarm system is in set condition.

4. Press the "UNLOCK" button momentarily on the keyless transmitter or the access key. When the door of the driver's seat is unlocked, the security indicator light operates (flashes once in three seconds), and the alarm system enters the release mode.

5. Press the "LOCK" button once on the keyless transmitter with one of the doors open. Check that the buzzer sounds 5 times to give the door not fully closed warning. All doors are locked when closed, and the security indicator light flashes quickly for 30 seconds. After that, it flashes slowly twice, and the alarm system is in set condition.
6. Press the "UNLOCK" button momentarily on the keyless transmitter. When the door of the driver's seat is unlocked, the security indicator operates (flashes once in three seconds), and the alarm system enters the release mode.
7. With one of the doors open, press the "LOCK" side of the power door lock switch. All doors are locked when closed, and the security indicator light flashes quickly for 30 seconds. After that, it flashes slowly twice, and the alarm system is in set condition.
 - Driver's side

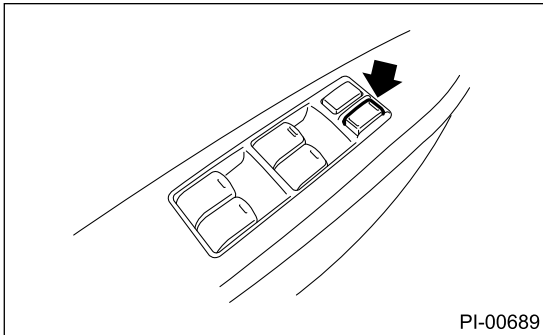

- Passenger's side

8. When the alarm system is in the set condition, use the inner lock knob to unlock the door, and open the door. Check if the alarm condition happens (horn sounds continuously, hazard light blinks, security indicator illuminates). Check if this condition lasts for a maximum of three minutes or until the "UNLOCK" button of the keyless transmitter or the access key is pressed.

Note:

The alarm condition will continue for 3 minutes with the door opened, and the alarm condition will cease within 30 seconds once the door is closed after alarm activation.

9. On models equipped with an impact sensor, hit the windshield glass with your hand with the alarm system in the monitoring set condition, to check that the alarm condition occurs.

10. Turn the ignition switch to ON and check that the security indicator light indicates the alarm history.

Note:

- **When alarm history for the opening of door is present, the security indicator light illuminates for one second and then blinks 5 times.**
- **When alarm history for the opening of trunk is present, the security indicator light illuminates for one second and then blinks 4 times.**
- **When alarm history for the opening of front hood is present, the security indicator light illuminates for one second and then blinks 3 times.**
- **When alarm history for the impact sensor is present, the security indicator light illuminates for one second and then blinks twice.**
- **When warning history for the impact sensor is present, the security indicator light illuminates for one second and then blinks once.**
- **When more than one histories are present, the alarm history with higher priority is indicated. (Items with higher priority are listed above.)**

11. Press the "LOCK" button on the keyless transmitter or access key momentarily to arm the alarm system. Press the "UNLOCK" button on the keyless transmitter momentarily to disarm the alarm system.

- 12.** Turn the ignition switch to ON and check that the security indicator light does not indicate the alarm history. (The security indicator light remains OFF.)
- 13.** When none of above is applicable, perform troubleshooting for the security system.

26. SEAT

- 1.** Check the seat surfaces for stains or dirt.
- 2.** Check that each seat provides full functionality in sliding, reclining, lifter, and tilting. Check all available functions of the rear seat such as backrest tilt knob.
- 3.** Check the passenger's seat occupant detection system.
 - (1) Empty the passenger's seat and turn the ignition switch to ON.
 - (2) Check that the passenger airbag ON/OFF indicator lights both turn on simultaneously for approximately six seconds, and after turning off for two seconds, only the OFF light illuminates.
- 4.** With a person weighing approximately 70 kg (155 lb) or more sitting in the passenger's seat, check whether the ON light of the passenger's airbag ON/OFF indicator illuminates or not.
- 5.** Have the passenger get out of the passenger's seat, and check whether the OFF light of the passenger side airbag ON/OFF indicator illuminates.

27. SEAT BELT

- 1.** Check installation condition of seat belt.
- 2.** Pull out the seat belt and then release it. Check that the belt retracts smoothly.
- 3.** Check seat belt warning function.
 - (1) Turn the ignition switch to ON with the driver's and passenger's seat belt detached.
 - (2) Check the driver's and passenger's seat belt warning light blink for approx. 6 seconds and the buzzer sounds intermittently.
 - (3) Then, check the seat belt warning light illuminates and blinks repeatedly at a cycle of approx. 15 seconds. (If no passenger is on the passenger's seat, the seat belt warning light on passenger's seat does not operate.)

28. TPMS (U.S. MODEL)

- 1.** Turn the ignition switch to ON, and check that the TPMS warning light is in a normal operation condition.
 - Normal operation (IG ON (light check))

2. If the TPMS warning light display does not operate normally, check and repair the system.  [Ref. to TIRE PRESSURE MONITORING SYSTEM \(DIAGNOSTICS\)>Basic Diagnostic Procedure.](#)

29. GROMMET INSTALLATION

Install the grommet provided in the rear seat to the tie-down hole.

Caution:

Make sure that the tie-down hole is firmly plugged with the grommet. Otherwise, dust, smell, etc. may come into the passenger compartment indirectly from the rear quarter, via the side sill from the tie-down hole.

(1) Grommet

30. DELIVERY (TEST) MODE

1. Install the delivery (test) mode fuse with ignition switch to OFF.

Caution:

Do not use any fuses that are installed on the vehicle.

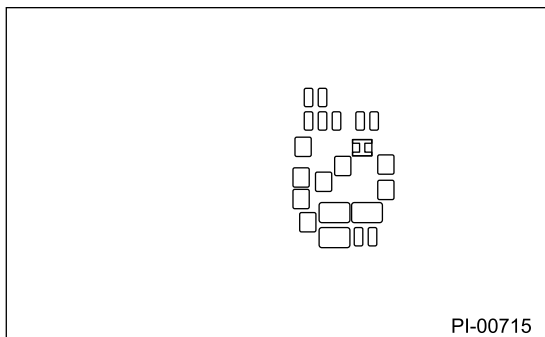

2. Turn the ignition switch to ON and check that the malfunction indicator light starts blinking.
3. If the malfunction indicator light blinks, return the ignition key to LOCK.

4. Remove the delivery (test) mode fuse and attach it to the spare fuse holder provided on the fuse box cover.
5. Then, turn the ignition key to ON again.
6. Make sure that the malfunction indicator light is off. If the malfunction indicator light blinks, carry out an engine diagnosis.

31. IMMOBILIZER SYSTEM

1. Check that the engine starts with all keys that are equipped on vehicle.
2. When starting the engine, check that the security indicator light goes off.
3. Check that the security indicator light blinks in 60 seconds after turning the ignition switch from ON to ACC or to OFF, or immediately after removing the key. (Models without the keyless access with push button start)
4. Immediately after turning ignition switch from ON to OFF, or with the key not in the vehicle and when opening/closing a door while the ignition switch is in ON or ACC with the engine stopped, check that the security indicator light is blinking. (Model with keyless access with push button start)

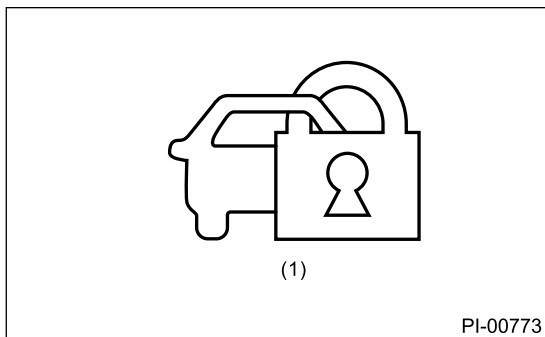

(1) Security indicator light

Note:

If malfunctions occur, refer to "IMMOBILIZER (DIAGNOSTICS)".  [Ref. to IMMOBILIZER \(DIAGNOSTICS\)>Basic Diagnostic Procedure.](#)

32. PUSH BUTTON START FUNCTION

• CVT model

1. Get into the vehicle while carrying the access key, with the vehicle in P range and the brake pedal OFF, and check that it cycles through ACC → IGN ON → IGN OFF every time the push button ignition switch is pressed, and that the indicator light for the push button ignition switch is illuminated in orange when the ignition switch is in the ACC ON and IGN ON positions.
2. Get into the vehicle while carrying the access key, with the vehicle in P range and the brake pedal ON, check that the indicator light for the push button ignition switch is illuminated in green.

Note:

While the select lever button is being pressed, the indicator light of the push button ignition switch does not illuminate in green even if the shift position is in the P range.

3. Get into the vehicle while carrying the access key, with the vehicle in P range and the brake pedal ON, check that the engine starts when you press the push button ignition switch.
4. With the vehicle stopped, the engine running and in P range, check that the engine stops when you press the push button ignition switch.

5. With the vehicle stopped, the engine running and in N range, check that the engine stops when you press the push button ignition switch, and cycles through ACC → IGN ON each time you press the push button ignition switch.

- **MT model**

1. Get into the vehicle while carrying the access key, with the clutch pedal OFF, and check that it cycles through ACC → IGN ON → IGN OFF every time the push button ignition switch is pressed, and that the indicator light for the push button ignition switch is illuminated in orange when the ignition switch is in the ACC ON and IGN ON positions.
2. Get into the vehicle while carrying the access key, with the clutch pedal ON, check that the indicator light for the push button ignition switch is illuminated in green.
3. Get into the vehicle while carrying the access key, with the clutch pedal ON, check that the engine starts when you press the push button ignition switch.
4. With the vehicle stopped and the engine running, check that the engine stops when you press the push button ignition switch.

33. STARTING CONDITION

Start the engine and check that the engine starts smoothly. If the battery voltage is low, recharge or replace the battery. If any noises are observed, immediately stop the engine and check and repair the abnormal components.

34. EXHAUST SYSTEM

Listen to the exhaust noise to see if no exhaust gas leak or abnormal noises are observed.

35. INDICATOR LIGHT AND WARNING LIGHT

Check that all indicator lights and warning lights operate normally.

36. HEATER & VENTILATION

Operate the heater & ventilation system to check for normal airflow outlet control, air inlet control, airflow capacity and heating performance.

37. AIR CONDITIONER

Operate the air conditioner. Check that the A/C compressor operates normally and enough cooling is provided.

Note:

To prevent the insufficient lubrication of the air conditioner, operate the air conditioner for five minutes at idling.

38. MULTI-FUNCTION DISPLAY (MFD)

Check that the Multi-Function Display (MFD) function operates normally. (Refer to the owner's manual for the operation procedures.)

39. AUDIO

Check that all radio functions operate, the speakers emit sound properly and the noise is at an acceptable level. Also check the CD unit and AUX unit operations.

40. NAVIGATION SYSTEM

1. Check all display functions for normal operation. (Refer to the owner's manual for the operation procedures.)
2. Check that the navigation system operates normally.
3. Check that the rearview camera operates normally.

41. TELEMATICS SYSTEM

Check that the indicator light on the overhead console or on the stereo camera cover assembly goes off.

42. ACCESSORY POWER SUPPLY SOCKET

1. Check the operation of the front accessory power supply socket.
2. Check operation of the accessory power supply socket in console box.

43. LIGHTING SYSTEM

1. Check the headlight operations.
2. Check the stop light operation.
3. Check other lights for normal operations.

44. WIPER DEICER

Check that the wiper deicer operates normally.

Note:

When an ambient temperature is 5°C or more, wiper deicer operation is cancelled. Press the switch for 3 seconds or more to perform the compulsory operation.

45. ILLUMINATION CONTROL

Check that the illumination control operates normally.

46. WINDOW WASHER SYSTEM

Check that the window washer system injects the washer fluid to the specified area of the windshield.

 [Ref. to WIPER AND WASHER SYSTEMS>Front Washer Nozzle and Hose>ADJUSTMENT.](#)

47. WIPER SYSTEM

Check that the front wiper operates normally.

48. POWER WINDOW

- Operate the power window switches one by one to check that each of the power windows goes up and down without noises.
- Check AUTO UP/AUTO DOWN operate properly by operating the power window switch on driver's and passenger's sides.

Caution:

If battery has been removed, AUTO UP does not operate properly because initialized. In this case, perform the initial setting (reset A) and check AUTO UP operates properly.

Note:

Check the power window if the door glass of the driver's and passenger's seats do not open/close automatically.  [Ref. to GLASS/WINDOWS/MIRRORS>Power Window System>INSPECTION.](#)

49. SUNROOF

Check that the sunroof operates normally.

Note:

For details concerning sunroof initialization, refer to the "SR" section.  [Ref. to SUNROOF/T-TOP/CONVERTIBLE TOP \(SUNROOF\)>Sunroof Control System>OPERATION > INITIALIZE OPERATION.](#)

50. REAR DEFOGGER SYSTEM

Check that the rear defogger system operates normally.

51. DOOR MIRROR

Check that the mirror heater and remote control mirror operate normally.

52. PARKING BRAKE

- Check that the parking brake operates normally. When pulling the parking brake lever with a force of 200 N (20 kgf, 45 lb), check that the lever stroke of parking brake lever is 7 to 8 notches.
- Check that the electronic parking brake operates properly by pressing the electronic parking brake switch while depressing the brake pedal.

53. BLIND SPOT DETECTION / REAR CROSS TRAFFIC ALERT (BSD/RCTA)

1. Check that the BSD/RCTA system is activated and deactivated correctly.
 - (1) Press the BSD/RCTA OFF switch to check that "BSD/RCTA OFF" is displayed in the combination meter.
 - (2) Press the BSD/RCTA OFF switch again to check that the indicators of the right and left side door mirrors illuminate → go off and "BSD/RCTA OFF" is displayed in the combination meter.
 - (3) Check that the BSD/RCTA error message is not displayed.
2. Check the rear bumper around the radar sensor for dirt, scratch, affixed stickers and poor paint coating.
 - If any dirt is found, clean it off so that the rear bumper is not damaged.
 - If any stickers are affixed, remove it so that the rear bumper is not damaged.
 - If the bumper is damaged or has poor paint coating, refer to "CAUTION" in "Blind Spot Detection/Rear Cross Traffic Alert (DIAGNOSTICS)".  [Ref. to Blind Spot Detection/Rear Cross Traffic Alert \(DIAGNOSTICS\)>General Description>CAUTION.](#)

(A) Radar sensor

54. REVERSE AUTOMATIC BRAKING (RAB)

1. Check that the RAB system is activated and deactivated correctly.
 - (1) Start the engine and let the engine idle for 6 seconds or more, and then shift the select lever to "R" range.
 - (2) Check that "RAB" and "RAB OFF" turn off in the combination meter.
 - (3) Check that the RAB warning screen is displayed on the MFD and "RAB" and "P Δ " indicators illuminate in green.
 - (4) Select "RAB" displayed on the screen, and check that "RAB OFF" is displayed in the combination meter when "RAB OFF/ON" is switched and "RAB OFF" is conducted.
 - (5) Select "P Δ " displayed on the screen, and check that "P Δ OFF/ON" can be switched.
2. Check the sonar sensor installed on the rear bumper for parts missing, dirt, scratch, foreign objects, etc.
 - The sensor surface must not stick out or sink in at 0.5 mm or more from the rear bumper surface. If the sensor surface largely sinks in, the sensor may not engaged in the holder behind the bumper. In this case, check the installation condition of the sensor after removing the bumper.
 - Make sure that there are no foreign objects (tape, stickers, dust or dirt) on the sonar sensor surface.
If there is a layer of foreign objects on the sensor surface, remove completely so that no residue remains.

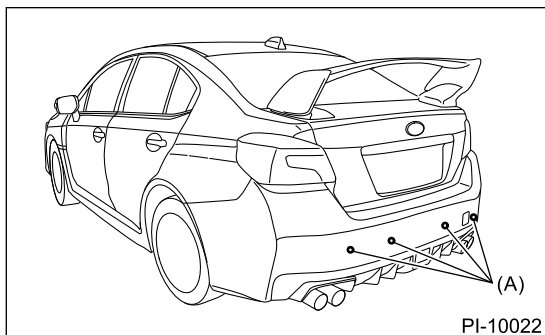

(A) Sonar sensor

55. DIAGNOSTIC TROUBLE CODE (DTC) CHECK

Read the diagnostic trouble code and check that the diagnostic trouble code is not detected.
If any diagnostic trouble code is detected, clear all.

1. Read Diagnostic Trouble Code

Note:

For detailed operation procedures, refer to "Application help".

2. Clear Memory Mode

Note:

For detailed operation procedures, refer to "Application help".

56. EyeSight ASSIST MONITOR

1. Turn the ignition switch to ON.
2. Check if the indicator light illuminates in order of yellow, red, and green twice for the initial illumination.

Note:

There is a malfunction, if it does not illuminate or illuminate only once for the initial setting.

57. AUTO VEHICLE HOLD (AVH) SYSTEM

Check that the AVH system is activated and deactivated correctly.

- Press the AVH switch, and check that the AVH ON indicator illuminates in the combination meter.
- Check that the vehicle hold condition is still maintained when the engine is started, the select lever is placed in "D" range and the brake pedal is released.
- Check that the AVH indicator illuminates in the combination meter while in the vehicle hold condition.
- Check that the vehicle hold condition is deactivated by depressing the accelerator pedal in the vehicle hold condition.

58. FRONT VIEW MONITOR

Press the MFD/VIEW switch while the vehicle is at a standstill, and check if an image ahead of the vehicle is displayed on MFD.

59. BRAKE TEST

Check the foot brake for normal operations.

Note:

On the model with brake assist mechanism, the brake pedal feels lighter when the brake pedal is depressed hard or quickly. However, those are not malfunction but the phenomena that occur when the brake assist mechanism functions properly.

60. SHIFT CONTROL

- **CVT**

1. Turn the ignition switch to ON.
2. While brake pedal is not depressed, check if the select lever does not move from "P" range.
3. While brake pedal is depressed, check if the select lever moves from "P" range.
4. Set the selector lever to each gear position and check the shifting while driving the vehicle. Operate the paddle shift at manual mode and check the shifting while driving the vehicle.

Selector position	Gear position							
	1st	2nd	3rd	4th	5th	6th	7th	8th
D	Continuously variable speed change							
Manual mode	OK	OK	OK	OK	OK	OK	OK	OK

*1: In S# mode

5. Set the select lever to other than "P" range. (Models without the keyless access with push button start)
 6. When the ignition switch is turned to OFF, check if the ignition key switch cannot be removed. (Models without the keyless access with push button start)
- **6MT (Except for STI model)**
 1. Check for smooth operation to each position. Especially, shift to 5th \longleftrightarrow 6th and to Rev, and check for stuck.
 2. Check the slider returns to the original position by shifting to the Rev and then back in neutral while pulling up the slider.
 3. If the shifting operation is not smooth, readjust the exposed length (a) of MT gear select cable by referring to the following figure.

- (a) Exposed length of MT gear select cable
- (A) Extend direction of exposed length of MT gear select cable
- (B) Shorten direction of exposed length of MT gear select cable
- (C) Specification of exposed length (a)

- If the shift cannot be inserted to push the reverse lock bracket 5th and 6th.
→ Extend the exposed length (a) of MT gear select cable.
- When operate the select lever to 4th → 5th, it cannot be operated at select lever crank line.
→ Shorten the exposed length (a) of MT gear select cable.

- **6MT (STI model)**

- 1.** Check for smooth operation to each position.
- 2.** Check that the lever cannot be moved to the reverse position unless the slider is pulled up.
- 3.** Check that the lever can be moved to the reverse position when the slider is pulled up.

61. CRUISE CONTROL

Operate the cruise control system. Check that the system is activated and deactivated correctly.

62. SUBARU EyeSight

- Operate the EyeSight system. Check that the system is activated and deactivated correctly.
- Check the stereo camera cover opening for foreign matter.
- Check the glass in front of stereo camera for dirt and stickers.
- Check the lens and filter of the stereo camera for dirt such as fingerprints.
- Check the filter at lens portion of stereo camera for damage.
- According to the "PC" section, check the windshield glass and dashboard in front of stereo camera to make sure that no aftermarket part is adhered or attached in the prohibited area.  [Ref. to CAUTION](#)

[> CHECK WINDSHIELD GLASS INCLUDING PROHIBITED AREA FOR MODEL WITH HBA AND EyeSight.](#)

- When delivering the vehicle, explain to the customer to make sure not to touch the filter at lens portion of the stereo camera.

63. POWER STEERING FLUID (HYDRAULIC POWER STEERING MODEL)

Caution:

If any power steering fluid is spilt over the exhaust pipe, wipe it off with a cloth to avoid emitting smoke or causing a fire.

Check that the power steering fluid level is normal. If the amount of power steering fluid is insufficient, check that no leaks are found. Then, add the necessary amount of specified power steering fluid.

64. POWER STEERING SYSTEM (ELECTRIC POWER STEERING MODEL)

Check that the electric power steering warning light illuminates when the ignition switch is turned to ON, and that the electric power steering warning light goes off after the engine is started.

65. FLUID LEAKAGE

Check entire areas of the vehicle for any trace of coolant/oil (such as engine and gear oil)/fluid (such as transmission and brake) leaks.

66. WATER LEAK TEST

Spray the vehicle with water using a hose and check that no water enters the passenger compartment.

- Before performing the water leakage test, remove anything that may obstruct the operation or which must be kept dry.
- Close all the windows and doors securely. Close the front hood and trunk lid before starting the test.
- Spray the vehicle with water using a hose. The rate of water spray must be approx. 20 to 25 L (5.3 — 6.6 US gal, 4.4 — 5.5 Imp gal) per minute.

When spraying water on areas adjacent to the floor and wheel house, increase the pressure. When spraying water on areas other than the floor and wheel house, decrease the pressure. But the force of water must be made strong occasionally by pressing the end of the hose.

Note:

Be sure to keep the hose at least 10 cm (3.9 in) away from vehicle.

Check the following areas.

- Front window and body framework mating portion
- Door mating portions
- Glass mating portions
- Rear quarter window mating portions

- Rear window and body framework mating portion
- Around roof drips

If any dampness in the compartments is discovered after the water has been applied, carefully check all the areas that may have possibly contributed to the leak.

67. APPEARANCE 2

1. If protective film (wrap guard and Tyvek[®]) is applied, remove it.

Note:

- **It is easier to remove the protective film using steam.**
 - **For a vehicle left for a long time or at low temperature, sprinkle some water heated to 50 – 60°C (122 – 140°F) over the vehicle to raise its surface temperature before peeling off the protective film. Do not use the water heated to over 60°C (140°F).**
 - **Keep solvent from touching the resin or rubber parts. Do not use coating wax or solvent while the component surface temperature is high due to hot weather etc.**
 - **Dispose of the protective film as burnable industrial garbage.**
 - **If any label is attached to the fog light lens, remove it.**
2. Check the whole vehicle body for flaking paint, damage by transportation, corrosion, dirt, cracks or blisters.

Note:

 - **It is better to determine an inspection pattern in order to avoid missing an area, since the total inspection area is wide.**
 - **Do not repair the body paint unless absolutely necessary. Also, if the vehicle is in need of repair to remove scratches or corroded paint, the repair area must be limited to the minimum. Re-painting and spray painting must be avoided as much as possible.**
 3. Check each window glass for scratches carefully. Slight damage may be removed by polishing with cerium oxide. (Fill a cap half with cerium oxide, and add warm water to it. Then agitate the content until it turns to wax. Apply this wax to a soft cloth, and polish the glass with it.)
 4. Check each portion of the vehicle body and underside components for the formation of rust. If rust is discovered, remove it with sandpaper of #80 to #180 and treat the surface with rust preventive. After this treatment is completed, flush the portion thoroughly, and prepare the surface for repair painting.
 5. Check each portion of body and all of the exterior parts for deformation or distortion. Also, check each light lens for cracks.
 6. Peel the protective tape, vinyl wrapping and identification seal attached to the following places.
 - Seat
 - Door trim
 - Door trim SW PNL (each door)
 - Floor carpet
 - Side sill (with SUS plate RH/LH)
 - Fuel opener lever
 - Rear shelf
 - Aluminum pedal
 - Steering wheel (model with ultra suede steering wheel)

PERIODIC MAINTENANCE SERVICES

PM

1. General Description
2. Schedule
3. Engine Oil
4. Engine Oil Filter
5. Spark Plug
6. V-belt
7. Timing Belt
8. Fuel Line
9. Fuel Filter
10. Air Cleaner Element
11. Cooling System
12. Engine Coolant
13. Clutch System
14. Transmission Gear Oil
15. CVTF
16. Front & Rear Differential Gear Oil
17. Brake Line
18. Brake Fluid
19. Disc Brake Pad and Disc
20. Parking Brake
21. Suspension
22. Wheel Bearing
23. Axle Boots & Joints
24. Tire Inspection and Rotation
25. Steering System (Power Steering)
26. A/C Filter

PERIODIC MAINTENANCE SERVICES > General Description

GENERAL DESCRIPTION

Be sure to perform periodic maintenance in order to maintain vehicle performance and find problems before they occur.

PERIODIC MAINTENANCE SERVICES > Schedule

MAINTENANCE SCHEDULE

1. MODEL WITH US SPECIFICATION

Maintenance item		Maintenance interval [Number of months or km (miles), whichever occurs first]													To be continued to the next table.	Remarks
		3	6	12	18	24	30	36	42	48	54	60	66			
	Months	3	6	12	18	24	30	36	42	48	54	60	66			
	× 1,000 km	4.8	9.6	19.2	28.8	38.4	48	57.6	67.2	76.8	86.4	96	105.6			
	× 1,000 miles	3	6	12	18	24	30	36	42	48	54	60	66			
1	Engine oil		R	R	R	R	R	R	R	R	R	R	R		Note 1.	
2	Engine oil filter		R	R	R	R	R	R	R	R	R	R	R		Note 1.	
3	Spark plug											R				
4	V-belt						I					I				
5	Timing belt														STI model	
6	Fuel line						I					I			Note 4. Note 5.	
7	Fuel filter														Note 2. Note 5.	
8	Air cleaner element						R					R			Note 6.	
9	Cooling system						I					I			Note 8.	
10	Engine coolant	Replace after the first 11 years or 220,000 km (137,500 miles), and every six years or 120,000 km (75,000 miles) thereafter													Note 8.	
11	Clutch system			I		I		I		I		I				
12	Transmission gear oil						I					I				

Maintenance item		Maintenance interval [Number of months or km (miles), whichever occurs first]														
1 3	CVTF						I						I			
1 4	Front & rear differential gear oil						I						I			
1 5	Brake line			I		I		I		I			I			Note 4.
1 6	Brake fluid / clutch fluid (MT model only)						R						R			Note 3.
1 7	Disc brake pad and disc			I		I		I		I			I			Note 4.
1 8	Parking brake			I		I		I		I			I			Note 4.
1 9	Suspension			I		I		I		I			I			Note 4.
2 0	Wheel bearing												I			
2 1	Axle boots and joints			I		I		I		I			I			Note 4.
2 2	Tire rotation	Perform every 10,000 km (6,000 miles).													Note 7.	
2 3	Steering system (Power steering)			I		I		I		I			I			Note 4.
2 4	A/C filter	Replace every 12 months or 19,200 km (12,000 miles)													Note 6.	

Maintenance item		Maintenance interval [Number of months or km (miles), whichever occurs first]												Remarks
		Continued from previous table	72	78	84	90	96	102	108	114	120	126	132	
	Months													
	× 1,000 km		115 .2	124 .8	134 .4	144	153 .6	163 .2	172 .8	182 .4	192	201 .6	211 .2	
	× 1,000 miles		72	78	84	90	96	102	108	114	120	126	132	
1	Engine oil		R	R	R	R	R	R	R	R	R	R	R	Note 1.
2	Engine oil filter		R	R	R	R	R	R	R	R	R	R	R	Note 1.
3	Spark plug										R			
4	V-belt					I					I			
5	Timing belt						R							STI model
6	Fuel line					I					I			Note 4. Note 5.
7	Fuel filter		R											Note 2. Note 5.
8	Air cleaner element					R					R			Note 6.
9	Cooling system					I					I			Note 8.
10	Engine coolant	Replace after the first 11 years or 220,000 km (137,500 miles), and every six years or 120,000 km (75,000 miles) thereafter											Note 8.	
11	Clutch system		I		I		I		I		I		I	
12	Transmission gear oil					I					I			
13	CVTF					I					I			
14	Front & rear differential gear oil					I					I			
15	Brake line		I		I		I		I		I		I	Note 4.
16	Brake fluid / clutch fluid (MT)					R					R			Note 3.

Maintenance item		Maintenance interval											
		[Number of months or km (miles), whichever occurs first]											
	model only)												
1 7	Disc brake pad and disc		I		I		I		I		I		Note 4.
1 8	Parking brake		I		I		I		I		I		Note 4.
1 9	Suspension		I		I		I		I		I		Note 4.
2 0	Wheel bearing										I		
2 1	Axle boots and joints		I		I		I		I		I		Note 4.
2 2	Tire rotation	Perform every 10,000 km (6,000 miles).											Note 7.
2 3	Steering system (Power steering)		I		I		I		I		I		Note 4.
2 4	A/C filter	Replace every 12 months or 19,200 km (12,000 miles)											Note 6.

Symbol

R: Replace

I: Inspection

P: Perform

Note:

1. When the vehicle is used under severe conditions, replace the engine oil and engine oil filter every 3 months or 4,800 km (3,000 miles).
2. When the vehicle is used under extremely low or high temperature conditions, the fuel filter may become dirty. Therefore, it should be replaced frequently.
3. When the vehicle is used in high humidity area or mountain area, replace the brake fluid every 15 months or 24,000 km (15,000 miles).
4. When the vehicle is used under severe conditions, replace every 6 months or 9,600 km (6,000 miles).
5. This inspection is not required to maintain emission warranty eligibility and it does not affect the manufacturer's obligations under EPA's in-use compliance program.
6. When the vehicle is used in extremely dusty conditions, it should be replaced more often.
7. A tire should be replaced when the tread wear indicator appears as a solid band across the tread. The indicators appear when the remaining tread has been worn to 1.6 mm (0.063 in) or less.
8. To prevent cooling system leakage, be sure to add SUBARU genuine cooling system conditioner when replacing coolant.

Examples of severe conditions

- a. Drive repeatedly at short distance. (Maintenance items 1 and 2)
- b. Drive repeatedly on bumpy muddy road. (Maintenance items 15, 17 and 19)
- c. Drive repeatedly in dusty conditions. (Maintenance items 7 and 23)

- d. Drive in extremely cold weather. (Maintenance items 1, 2, 16, 18, 20 and 22)
- e. Area where salt or other corrosive used. (Maintenance items 5, 15, 16, 17 and 20)
- f. Coastal area. (Maintenance item 5)

PERIODIC MAINTENANCE SERVICES > Engine Oil

INSPECTION

Refer to "LU" section for engine oil inspection. [Ref. to LUBRICATION\(STI\)>Engine Oil>INSPECTION.](#) [Ref. to LUBRICATION\(w/o STI\)>Engine Oil>INSPECTION.](#)

PERIODIC MAINTENANCE SERVICES > Engine Oil

REPLACEMENT

Refer to "LU" section for engine oil replacement. [Ref. to LUBRICATION\(STI\)>Engine Oil>REPLACEMENT.](#) [Ref. to LUBRICATION\(w/o STI\)>Engine Oil>REPLACEMENT.](#)

PERIODIC MAINTENANCE SERVICES > Engine Oil Filter

REPLACEMENT

Refer to "LU" section for engine oil filter replacement. [Ref. to LUBRICATION\(STI\)>Engine Oil Filter>REMOVAL.](#) [Ref. to LUBRICATION\(w/o STI\)>Engine Oil Filter>REMOVAL.](#)

PERIODIC MAINTENANCE SERVICES > Spark Plug

REPLACEMENT

Refer to "IG" section for spark plug replacement. [Ref. to IGNITION\(STI\)>Spark Plug>REMOVAL.](#) [Ref. to IGNITION\(w/o STI\)>Spark Plug>REMOVAL.](#)

PERIODIC MAINTENANCE SERVICES > V-belt

INSPECTION

Refer to "ME" section for V-belt inspection. [Ref. to MECHANICAL\(STI\)>V-belt>INSPECTION.](#) [Ref. to MECHANICAL\(w/o STI\)>V-belt>INSPECTION.](#)

PERIODIC MAINTENANCE SERVICES > V-belt

REPLACEMENT

Refer to "ME" section for V-belt replacement. [Ref. to MECHANICAL\(STI\)>V-belt>REMOVAL.](#) [Ref. to MECHANICAL\(w/o STI\)>V-belt>REMOVAL.](#)

PERIODIC MAINTENANCE SERVICES > Timing Belt

INSPECTION

Refer to "ME" section for timing belt inspection. [Ref. to MECHANICAL\(STI\)>Timing Belt>INSPECTION.](#)

PERIODIC MAINTENANCE SERVICES > Timing Belt

REPLACEMENT

Refer to "ME" section for timing belt replacement. [Ref. to MECHANICAL\(STI\)>Timing Belt>REMOVAL.](#)

PERIODIC MAINTENANCE SERVICES > Fuel Line

INSPECTION

The fuel line is located mostly internally, so check pipes, areas near pipes, and engine compartment piping for rust, hose damage, loose band, etc. If faulty parts are found, repair or replace them. [Ref. to FUEL INJECTION \(FUEL SYSTEMS\)\(STI\)>Fuel Delivery, Return and Evaporation Lines>INSPECTION.](#) [Ref. to FUEL INJECTION \(FUEL SYSTEMS\)\(w/o STI\)>Fuel Delivery and Evaporation Lines>INSPECTION.](#)

PERIODIC MAINTENANCE SERVICES > Fuel Filter

REPLACEMENT

For fuel filter replacement procedure, refer to "FU" section. [Ref. to FUEL INJECTION \(FUEL SYSTEMS\) \(STI\)>Fuel Filter>REMOVAL.](#) [Ref. to FUEL INJECTION \(FUEL SYSTEMS\)\(w/o STI\)>Fuel Filter>REMOVAL.](#)

PERIODIC MAINTENANCE SERVICES > Fuel Filter

INSPECTION

If the filter is clogged, or if the replacement interval has been reached, replace it.

PERIODIC MAINTENANCE SERVICES > Air Cleaner Element

REPLACEMENT

Refer to "IN" section for air cleaner element replacement. [Ref. to INTAKE \(INDUCTION\)\(STI\)>Air Cleaner Element>REMOVAL.](#) [Ref. to INTAKE \(INDUCTION\)\(w/o STI\)>Air Cleaner Element>REMOVAL.](#)

PERIODIC MAINTENANCE SERVICES > Cooling System

INSPECTION

1. RADIATOR

Check that there are no engine coolant leaks from the hose connections. Refer to "CO" section for radiator inspection. [Ref. to COOLING\(STI\)>Radiator>INSPECTION.](#) [Ref. to COOLING\(w/o STI\)>Radiator>INSPECTION.](#)

2. RADIATOR CAP

Refer to "CO" section for radiator cap inspection. [Ref. to COOLING\(STI\)>Radiator Cap>INSPECTION.](#) [Ref. to COOLING\(w/o STI\)>Radiator Cap>INSPECTION.](#)

3. COOLING FAN

Refer to "CO" section for cooling fan inspection. [Ref. to COOLING\(STI\)>Radiator Fan System>INSPECTION.](#) [Ref. to COOLING\(w/o STI\)>Radiator Fan System>INSPECTION.](#)

4. COOLING SYSTEM

Start the engine, and then inspect that it does not overheat or it is not cooled excessively. If it overheats or it is cooled excessively, check the cooling system.

PERIODIC MAINTENANCE SERVICES > Engine Coolant

INSPECTION

Caution:

- **Do not use water instead of coolant.**
- **Refer to "RM" section for the recommended engine coolant. [Ref. to RECOMMENDED MATERIALS > ENGINE COOLANT.](#)**

- 1.** Park the vehicle on a level surface.
- 2.** Make sure the engine coolant level in the reservoir tank is between "FULL" and "LOW" when the engine is cold.

Note:

If the engine coolant level drops, make sure that there are no engine coolant leakage, and add engine coolant to the "FULL" line.

- 3.** Remove the radiator cap and make sure that the radiator is filled with engine coolant up to the filler neck position.

PERIODIC MAINTENANCE SERVICES > Engine Coolant

REPLACEMENT

Refer to "CO" section for engine coolant replacement. [Ref. to COOLING\(STI\)>Engine Coolant>REPLACEMENT > DRAINING OF ENGINE COOLANT.](#) [Ref. to COOLING\(w/o STI\)>Engine Coolant>REPLACEMENT > DRAINING OF ENGINE COOLANT.](#)

PERIODIC MAINTENANCE SERVICES > Clutch System

INSPECTION AND ADJUSTMENT

Refer to "CL" section for inspection and adjustment of clutch system. [Ref. to CLUTCH SYSTEM>Clutch Pedal>INSPECTION.](#) [Ref. to CLUTCH SYSTEM>Clutch Pedal>ADJUSTMENT.](#)

PERIODIC MAINTENANCE SERVICES > Transmission Gear Oil

INSPECTION

Refer to "6MT (TY75)" or "6MT (TY85)" section for transmission gear oil inspection. [Ref. to MANUAL TRANSMISSION AND DIFFERENTIAL\(6MT\)\(TY75\)>Transmission Gear Oil>INSPECTION.](#) [Ref. to MANUAL TRANSMISSION AND DIFFERENTIAL\(6MT\)\(TY85\)>Transmission Gear Oil>INSPECTION.](#)

PERIODIC MAINTENANCE SERVICES > Transmission Gear Oil

REPLACEMENT

Refer to "6MT (TY75)" or "6MT (TY85)" section for transmission gear oil replacement. [Ref. to MANUAL TRANSMISSION AND DIFFERENTIAL\(6MT\)\(TY75\)>Transmission Gear Oil>REPLACEMENT.](#) [Ref. to MANUAL TRANSMISSION AND DIFFERENTIAL\(6MT\)\(TY85\)>Transmission Gear Oil>REPLACEMENT.](#)

PERIODIC MAINTENANCE SERVICES > CVTF

INSPECTION

Refer to "CVT (TR690)" section for CVTF inspection. [_Ref. to CONTINUOUSLY VARIABLE TRANSMISSION\(TR690\)>CVTF>INSPECTION.](#)

PERIODIC MAINTENANCE SERVICES > CVTF

REPLACEMENT

Refer to "CVT (TR690)" section for CVTF replacement. [_Ref. to CONTINUOUSLY VARIABLE TRANSMISSION\(TR690\)>CVTF>REPLACEMENT.](#)

PERIODIC MAINTENANCE SERVICES > Front & Rear Differential Gear Oil

INSPECTION

1. FRONT DIFFERENTIAL (MT MODEL)

Front differential gear oil of MT model lubricates the transmission and differential together. Refer to "6MT (TY75)" or "6MT (TY85)" section for inspection. [Ref. to MANUAL TRANSMISSION AND DIFFERENTIAL\(6MT\)\(TY75\)>Transmission Gear Oil>INSPECTION.](#) [Ref. to MANUAL TRANSMISSION AND DIFFERENTIAL\(6MT\)\(TY85\)>Transmission Gear Oil>INSPECTION.](#)

2. FRONT DIFFERENTIAL (CVT MODEL)

Refer to "CVT (TR690)" section for inspection of CVT model front differential gear oil. [Ref. to CONTINUOUSLY VARIABLE TRANSMISSION\(TR690\)>Differential Gear Oil>INSPECTION.](#)

3. REAR DIFFERENTIAL

Refer to "DI" section for rear differential gear oil inspection. [Ref. to DIFFERENTIALS>Differential Gear Oil>INSPECTION.](#)

PERIODIC MAINTENANCE SERVICES > Front & Rear Differential Gear Oil

REPLACEMENT

1. FRONT DIFFERENTIAL (MT MODEL)

Front differential gear oil of MT model lubricates the transmission and differential together. Refer to "6MT (TY75)" or "6MT (TY85)" section for replacement. [Ref. to MANUAL TRANSMISSION AND DIFFERENTIAL\(6MT\)\(TY75\)>Transmission Gear Oil>REPLACEMENT.](#) [Ref. to MANUAL TRANSMISSION AND DIFFERENTIAL\(6MT\)\(TY85\)>Transmission Gear Oil>REPLACEMENT.](#)

2. FRONT DIFFERENTIAL (CVT MODEL)

Refer to CVT (TR690) section for replacement of CVT model front differential gear oil. [Ref. to CONTINUOUSLY VARIABLE TRANSMISSION\(TR690\)>Differential Gear Oil>REPLACEMENT.](#)

3. REAR DIFFERENTIAL

Refer to "DI" section for rear differential gear oil replacement. [Ref. to DIFFERENTIALS>Differential Gear Oil>REPLACEMENT.](#)

PERIODIC MAINTENANCE SERVICES > Brake Line

INSPECTION

1. BRAKE LINE

1. Check for scratches, swelling, corrosion, traces of fluid leakage on the brake hoses or pipe joints.
2. Make sure that brake pipes/hoses do not interfere with adjacent parts and there is no loose connector/clamp during driving.
3. Check any trace of fluid leakage, scratches, etc. on master cylinder, wheel cylinder and hydraulic unit.

Note:

- **When the brake fluid level in the reservoir tank is lower than specified limit, the brake warning light on the combination meter will illuminate.**
- **Visually check the brake hose for damage. (Use a mirror where it is difficult to see)**

- (1) Front brake hose
- (2) Front brake pipe
- (3) Clamp

- (1) Brake pipe
- (2) Rear brake hose
- (3) Clamp

2. SERVICE BRAKE

Refer to "BR" section for foot brake inspection. [Ref. to BRAKE>Brake Pedal>INSPECTION.](#)

3. BRAKE SERVO SYSTEM

1. With the engine off, depress the brake pedal several times applying the same pedal force. Check that the travel distance should not change.
2. With the brake pedal depressed, start the engine. Check that the pedal moves slightly toward the floor.
3. With the brake pedal depressed, stop the engine and keep the pedal depressed for 30 seconds. Check that the pedal height does not change.
4. A check valve is built into the vacuum hose. Disconnect the vacuum hose to inspect function of check valve.
Check that check valve ventilates from booster side to engine side. Also, check that there is no ventilation from engine side to booster side.

- (A) Brake booster
- (B) Check valve
- (C) Engine side
- (D) Vacuum hose

5. Check the vacuum hose for cracks or other damage.

Caution:

When installing the vacuum hose on the engine and brake booster, do not use soapy water or lubricating oil on their connections.

6. Check that the vacuum hose is securely tightened.

PERIODIC MAINTENANCE SERVICES > Brake Fluid

INSPECTION

Refer to "BR" section for brake fluid inspection. [_Ref. to BRAKE>Brake Fluid>INSPECTION.](#)

PERIODIC MAINTENANCE SERVICES > Brake Fluid

REPLACEMENT

Refer to "BR" section for brake fluid replacement. [_Ref. to BRAKE>Brake Fluid>REPLACEMENT.](#)

PERIODIC MAINTENANCE SERVICES > Disc Brake Pad and Disc

INSPECTION

Refer to "BR" section for disc brake pad and disc inspection. [_Ref. to BRAKE>Front Brake Pad>INSPECTION.](#) [_Ref. to BRAKE>Rear Brake Pad>INSPECTION.](#) [_Ref. to BRAKE>Front Disc Rotor>INSPECTION.](#) [_Ref. to BRAKE>Rear Disc Rotor>INSPECTION.](#)

PERIODIC MAINTENANCE SERVICES > Parking Brake

INSPECTION

1. DRUM IN DISC TYPE MODEL

Refer to "PB" section for drum in disc type model parking brake inspection. [Ref. to PARKING BRAKE>Parking Brake Assembly \(Rear Disc Brake\)>INSPECTION.](#)

2. ELECTRONIC PARKING BRAKE MODEL

Refer to "VDC (DIAGNOSTICS)" section for electronic parking brake model parking brake inspection. [Ref. to VEHICLE DYNAMICS CONTROL \(VDC\) \(DIAGNOSTICS\)>Basic Diagnostic Procedure>PROCEDURE.](#)

PERIODIC MAINTENANCE SERVICES > Parking Brake

ADJUSTMENT

Refer to "PB" section for parking brake adjustment. [Ref. to PARKING BRAKE>Parking Brake Assembly \(Rear Disc Brake\)>ADJUSTMENT.](#)

INSPECTION

1. FRONT SUSPENSION BALL JOINT

- 1.** Lift up the vehicle until front wheels are off ground.
- 2.** Grasp the bottom of tire and move it in and out in axial direction. If movement (B) is observed between the brake disc cover (A) and end of front arm (D), ball joint (C) may be excessively worn.
- 3.** Next, grasp the end of front arm (C) and move it up and down. If movement (A) between the housing (D) and front arm (C) boss is observed, ball joint (B) may be excessively worn.
- 4.** If the relative movement is observed in the preceding two steps, remove and inspect the ball joint. If the free play exceeds standard value, replace the ball joint. [_Ref. to FRONT SUSPENSION>Front Ball Joint.](#)
- 5.** Damage of dust boots
Visually inspect the ball joint dust boots. Replace if ball joint is damaged.

2. REAR SUSPENSION BALL JOINT

- 1.** Lift up the vehicle until rear wheels are off ground.
- 2.** Grasp the bottom of tire and move it in and out in axial direction.
- 3.** If movement is observed between the brake disc cover (A) and end of front lateral link (B), ball joint may be excessively worn.

4. Grasp the end of front lateral link (B) and move it up and down. If movement is observed between the housing (C) and front lateral link (B) boss, ball joint may be excessively worn.

5. If the movement related to the previous two steps is observed, replace the front lateral link. [Ref. to REAR SUSPENSION>Front Lateral Link.](#)

6. Damage of dust boots

Visually inspect the ball joint dust boots. Replace if front lateral link is damaged.

7. Check upper arm ball joint (D) in the same manner.

3. FRONT, REAR SUSPENSION BUSHING

1. Apply pressure with tire lever etc, and inspect the bushing for excessive wear or damage. If defective, replace the bushing.

- Front suspension bushing

- Rear suspension bushing

2. Visually check the pillow ball bushing of housing. Replace the housing if damaged.

4. WHEEL ARCH HEIGHT

Refer to "FS" section for wheel arch height inspection. [_Ref. to FRONT SUSPENSION>Wheel Alignment>INSPECTION > WHEEL ARCH HEIGHT.](#)

5. WHEEL ALIGNMENT

Measure and adjust the front and rear wheel alignment at a time. Refer to "FS" section for measurement and adjustment of wheel alignment. [_Ref. to FRONT SUSPENSION>Wheel Alignment>INSPECTION.](#)

6. OIL LEAKAGE OF STRUT AND SHOCK ABSORBER

Visually inspect the front strut and rear shock absorber for oil leakage. Replace the front strut and rear shock absorber if oil leaks excessively.

7. TIGHTNESS OF BOLTS AND NUTS

Check the bolts and nuts for looseness. Retighten the bolts and nuts to specified torque. If non-reusable parts are removed, replace them with new parts. [_Ref. to FRONT SUSPENSION>General Description.](#) [_Ref. to REAR SUSPENSION>General Description.](#)

8. DAMAGE TO SUSPENSION PARTS

Check the following parts and the fastening portion of the vehicle body for deformation or excessive rusting which impairs the suspension. Thoroughly remove the deposits of the lower spring seat of strut where dust or mud are likely piled up. If necessary, replace the damaged parts with new parts. If minor rust formation, pitting, etc. are noted, remove the rust and take rust prevention measure.

- Front suspension
 - Front arm
 - Front crossmember
 - Strut
- Rear suspension
 - Sub frame
 - Front lateral link
 - Rear lateral link
 - Upper arm
 - Trailing link
 - Shock absorber
- In the area where salt is sprayed to melt snow on a road in winter, check suspension parts for damage caused by rust every 12 months after lapse of 60 months. Take rust prevention measures as required.

INSPECTION

1. FRONT WHEEL BEARING

Note:

Inspect the condition of front wheel bearing grease.

1. Jack-up the front side of vehicle.
2. While holding the front wheel by hand, swing it in and out to check bearing free play.
3. Loosen the wheel nuts, and remove the front wheel.
4. If the bearing free play exists in step 2) above, attach a dial gauge to the hub and measure axial play in axial direction.

Service limit:

Straight-ahead position within 0.05 mm (0.0020 in)

5. Remove the bolts and self-locking nuts, and extract the front arm from front crossmember.
6. Remove the joint of front drive shaft from transmission. [Ref. to DRIVE SHAFT SYSTEM>Front Axle.](#)
7. While supporting the front drive shaft horizontally with one hand, turn the hub with the other hand to check for noise or binding.
If the hub is noisy or binds, replace the front axle.

2. REAR WHEEL BEARING

1. Jack-up the rear side of vehicle.
2. While holding the rear wheel by hand, swing it in and out to check bearing free play.
3. Loosen the wheel nuts, and remove the rear wheel.
4. If the bearing free play exists in step 2) above, attach a dial gauge to the hub and measure axial play in axial direction.

Service limit:

Straight-ahead position within 0.05 mm (0.0020 in)

5. Remove the joint of rear drive shaft from rear differential. [Ref. to DRIVE SHAFT SYSTEM>Rear Drive Shaft.](#)
6. While supporting rear drive shaft horizontally with one hand, turn the hub with the other hand to check for noise or binding.
If the hub is noisy or binds, replace the rear axle.

PERIODIC MAINTENANCE SERVICES > Axle Boots & Joints

INSPECTION

1. FRONT AND REAR AXLE BOOTS

Inspect the front axle boots (A) and rear axle boots (B) for deformation, damage or failure. If faulty, replace with new part. [_Ref. to DRIVE SHAFT SYSTEM>Front Drive Shaft.](#) [_Ref. to DRIVE SHAFT SYSTEM>Rear Drive Shaft.](#)

- Front

- Rear

2. PROPELLER SHAFT

Inspect the propeller shaft for damage or failure. If faulty, replace with new part. [_Ref. to DRIVE SHAFT SYSTEM>Propeller Shaft.](#)

PERIODIC MAINTENANCE SERVICES > Tire Inspection and Rotation

INSPECTION

Refer to "WT" section for tire inspection and rotation. [Ref. to WHEEL AND TIRE SYSTEM>Tire and Wheel>INSPECTION.](#)

PERIODIC MAINTENANCE SERVICES > Steering System (Power Steering)

INSPECTION

1. STEERING WHEEL

1. Set the steering wheel in a straight-ahead position, and check the wheel spokes to make sure they are correctly set in their specified positions.
2. Lightly turn the steering wheel to the left and right to determine the point where front wheels start to move.

Measure the distance of the movement of steering wheel (periphery).

Steering wheel free play:

0 – 17 mm (0 – 0.67 in)

(1) Steering wheel free play

Move the steering wheel toward the shaft to check if there is play in the direction.

Play limit:

0.5 mm (0.020 in)

3. Drive the vehicle and check the following items.
 - (1) Steering force:

The effort required for steering should be smooth and even at all points, and should not vary.
 - (2) Pulled to one side:

Steering wheel should not be pulled to one side while driving on a level surface.
 - (3) Wheel runout:

Steering wheel should not show any sign of runout.
 - (4) Return status:

Steering wheel should return to its original position after it has been turned and then released.

2. STEERING SHAFT JOINT

If steering wheel play is excessive, disconnect the universal joint of steering shaft and then check the play where the joints cross and yawing torque. Also, check the seal for damage or serrations for wear. If the joint is loose, retighten the mounting bolts to the specified torque. [Ref. to POWER ASSISTED SYSTEM \(POWER STEERING\)>Universal Joint.](#)

Tightening torque:

24 N·m (2.4 kgf-m, 17.4 ft-lb)

3. GEARBOX

1. Set the steering wheel in the straight position, then rotate it 90° in both the left and right directions.

While steering wheel is being rotated, check the looseness of the gearbox.

Tightening torque:

60 N·m (6.1 kgf-m, 44.3 ft-lb)

- Hydraulic power steering

- Electric power steering

2. Check the boot for damage, cracks or deterioration.

3. With the vehicle stopped on a level surface, quickly turn the steering wheel to the left and right. While steering wheel is being rotated, check the gear backlash. If any noise is noticed, adjust the gear backlash. [Ref. to POWER ASSISTED SYSTEM \(POWER STEERING\)>Electric Power Steering Gearbox>ADJUSTMENT > GEARBOX BACKLASH ADJUSTMENT.](#)

Adjust the hydraulic power steering as follows.

(1) Loosen the adjusting screw, and apply liquid gasket to at least 1/3 of the entire perimeter of adjusting screw thread.

Liquid gasket:

THREE BOND 1102

(1) Apply liquid gasket to 1/3 or more of the entire perimeter.

(2) Tighten the adjusting screw, then loosen it.

Caution:

Adjust the steering rack to the straight forward position.

Tightening torque:

25 N·m (2.5 kgf-m, 18 ft-lb)

(3) Tighten the adjusting screw, then loosen it.

(4) Tighten the adjusting screw.

Tightening torque:

5.9 N·m (0.6 kgf-m, 4.2 ft-lb)

(5) Then, return the adjusting screw by 5° and fix it.

(6) Install the lock nut. While holding the adjusting screw with wrench, tighten the lock nut using ST.

ST 926230000 SPANNER

Tightening torque (lock nut):

25 N·m (2.5 kgf-m, 18 ft-lb)

Hold the adjusting screw with wrench to prevent it from turning while tightening the lock nut.

4. TIE-ROD

1. Check the tie-rod and tie-rod end for bend, cracks or other damages.

(A) Tie-rod end

(B) Tie-rod

2. Confirm that the connections of knuckle ball joints for play, and then check for damage on dust boots and free play of ball studs. If castle nut is loose, retighten it to the specified torque, then tighten further up to a maximum of 60° until the cotter pin hole is aligned.

Tightening torque:

27 N·m (2.75 kgf-m, 19.9 ft-lb)

3. Check the tightening of tie-rod end lock nut. If it is loose, tighten it to the specified torque.

Tightening torque:

85 N·m (8.7 kgf-m, 62.7 ft-lb)

5. POWER STEERING FLUID LEVEL

Caution:

If any power steering fluid is spilt over the exhaust pipe, wipe it off with a cloth to avoid emitting smoke or causing a fire.

Note:

- **For electric power steering model, inspection is not necessary.**
 - **When the power steering fluid temperature is 20°C (68°F), check the fluid level on the "COLD" side.**
 - **When the power steering fluid temperature is 80°C (176°F), check the fluid level on the "HOT" side.**
- 1.** Stop the engine to park the vehicle on a level surface.
 - 2.** Check the fluid level using the scale on the outside of the reservoir tank. If the level is below "MIN", fill fluid up to "MAX" level.

Note:

If fluid level is at "MAX" level or above, drain fluid to keep the level in the specified range of indicator by using a syringe or the like.

Recommended fluid:

[Ref. to RECOMMENDED MATERIALS > FLUID.](#)

Fluid capacity:

[Ref. to SPECIFICATIONS>WRX STI>CAPACITY.](#)

6. POWER STEERING FLUID FOR LEAKS

Caution:

- **Wipe the leaked fluid off after correcting fluid leaks.**
- **Also pay attention to interference between hoses or pipes and other parts when inspecting fluid leaks.**
- **If any power steering fluid is spilt over the exhaust pipe, wipe it off with a cloth to avoid emitting smoke or causing a fire.**

For hydraulic power steering model, inspect the underside of oil pump, gearbox of power steering system, hoses, pipes and their couplings for fluid leaks.

If fluid leakage is found, tighten the mounting bolt (or nut) again or replace with a new part.

7. HOSES OF OIL PUMP FOR DAMAGES

For model with hydraulic power steering, check the pressure hose or return hose of the oil pump for cracks, swelling, damages. Replace the hose with a new part if necessary.

Caution:

When installing the hose, do not twist or bend.

8. POWER STEERING PIPES FOR DAMAGES

For model with hydraulic power steering, check the power steering pipe for corrosion or damages.

Replace the pipe with a new part if necessary.

9. GEARBOX BOOTS

Inspect both sides of the gearbox boot as follows, and correct the defects if necessary.

- 1.** The (A) and (B) positions of the gearbox boot are fitted in (A) and (C) grooves of gearbox and the rod.
- 2.** Clips are fitted onto the boot grooves to the positions (A) and (B) of the boot.
- 3.** Check that there is no cracks or holes in the boot.

Note:

Rotate (B) position of gearbox boot against the torsion produced by the adjustment of toe-in etc.

10. MOUNTING BOLT & NUT

Inspect the fitting bolts and nuts of oil pump and bracket for looseness, and retighten them if necessary.

11. HARNESS INSPECTION (ELECTRIC POWER STEERING MODEL)

Check the harness of the electric power steering for cracks or damages.

Replace the electric power steering gear box with a new part if necessary.

12. ELECTRIC POWER STEERING CONTROL MODULE INSPECTION (ELECTRIC POWER STEERING MODEL)

Check for the electric power steering diagnostic trouble codes. If the diagnostic trouble code is detected, perform the diagnosis. [Ref. to POWER ASSISTED SYSTEM \(POWER STEERING\) \(DIAGNOSTICS\)>Basic Diagnostic Procedure.](#)

Replace the steering gear box with a new part if necessary.

PERIODIC MAINTENANCE SERVICES > A/C Filter

REPLACEMENT

Refer to "AC" section for A/C filter replacement. [Ref. to HVAC SYSTEM \(HEATER, VENTILATOR AND A/C\)>A/C Filter>REPLACEMENT.](#)