

# FOREWORD

*FW*

---

1. Foreword

## FOREWORD

---

These manuals are used when performing maintenance, repair or diagnosis of WRX.

Applicable model:

2022MY VB\*\*\*\*

The manuals contain the latest information at the time of publication. Changes in the specifications, methods, etc. may be made without notice.

Refer to HELP for how to use this manual.

# SPECIFICATIONS

***SPC***

1. WRX

## SPECIFICATIONS > WRX

### DIMENSION

Model		2.4 L DOHC turbo	
Overall length	mm (in)	4,670 (183.8)	
Overall width	mm (in)	1,825 (71.9)	
Overall height (at C.W.* <sup>1</sup> )	mm (in)	1,465 (57.8)	
Wheelbase	mm (in)	2,670 (105.2) * <sup>2</sup> , 2,675 (105.2) * <sup>3</sup>	
Tread	Front	mm (in)	1,560 (61.5)
	Rear	mm (in)	1,570 (61.7) * <sup>2</sup> , 1,570 (61.8) * <sup>3</sup>
Minimum road clearance	mm (in)	135 (5.4)	

\*1: Curb weight

\*2: 17-inch model

\*3: 18-inch model

## SPECIFICATIONS > WRX

### ENGINE

Model		2.4 L DOHC turbo
Cylinder arrangement		Horizontally opposed, liquid cooled, 4-cylinder, 4-stroke gasoline engine
Valve system mechanism		Chain driven, double overhead camshaft, 4-valve/cylinder
Bore × Stroke	mm (in)	94.0 × 86.0 (3.70 × 3.39)
Displacement	cm <sup>3</sup> (cu in)	2,387 (146)
Compression ratio		10.6
Ignition order		1 – 3 – 2 – 4
Idle speed (For CVT model, select lever in "P" or "N" range. For MT model, gear shift lever in neutral position.) (no load)	r/min	700±100
Maximum output	kW (HP)/[r/min]	202 (271)/5,600
Maximum torque	N·m (kgf-m, ft-lb)/[r/min]	350 (35.7, 258)/2,000 – 5,200

## SPECIFICATIONS > WRX

### ELECTRICAL

Model		2.4 L DOHC turbo
Ignition timing	BTDC/{r/min }	7°±10°/700
Spark plug	Manufacturer and type* <sup>1</sup>	NGK: SILKFR8D6Y NGK: SILKFR8A6
Generator	Voltage and output	12 V — 150 A
Battery	Type	75D23L
	Nominal capacity	5HR: 53 Ah, 20HR: 62 Ah [25°C (77°F)]
	Nominal voltage	12 V
	CCA	470 A
	BCI group number* <sup>2</sup>	35

\*<sup>1</sup>: The type varies depending on when it was manufactured.

\*<sup>2</sup>: Use the information about the battery size as a reference. This information shall not be guaranteed by SUBARU CORPORATION.

## SPECIFICATIONS > WRX

### TRANSMISSION

#### 1. MT

Model		2.4 L DOHC turbo
Transmission type		6MT * <sup>1</sup>
Clutch type		DSPD * <sup>2</sup>
Gear ratio	1st	3.455
	2nd	1.947
	3rd	1.367
	4th	1.029
	5th	0.825
	6th	0.667
	Rev.	3.636
Front differential	Type of gear	Hypoid
	Gear ratio	4.111
Center differential	Type	Viscous coupling
Transfer	Gear ratio	1.000
Rear differential	Type of gear	Hypoid
	Gear ratio	4.111

\*1: 6-forward speeds and 1-reverse with synchromesh

\*2: Dry, single plate, diaphragm spring type

## 2. CVT

Model		2.4 L DOHC turbo
Transmission type		CVT
Clutch type		TCC
Gear ratio (including transfer reduction ratio)	Forward	3.490 — 0.506
	Rev.	3.394
Front differential	Type of gear	Hypoid
	Gear ratio	4.111
Transfer	Gear ratio	1.081
Rear differential	Type of gear	Hypoid
	Gear ratio	4.444

## SPECIFICATIONS > WRX

### STEERING SYSTEM

Model		2.4 L DOHC turbo
Gearbox	Type	Rack & pinion type
Type		Electric power steering
Lock-to-lock revolution number		2.5
Minimum turning radius	m (ft)	5.5 (18.05) * <sup>1</sup> , 5.6 (18.37) * <sup>2</sup>

\*<sup>1</sup>: 17-inch model

\*<sup>2</sup>: 18-inch model

## SPECIFICATIONS > WRX

### SUSPENSION

Model		2.4 L DOHC turbo
Front		Macpherson strut type suspension
Rear		Double-wishbone type suspension

## SPECIFICATIONS > WRX

### BRAKE

Model		2.4 L DOHC turbo
Service brake system		Dual circuit hydraulic with vacuum suspended power unit* <sup>1</sup> Electric brake booster pressure type dual circuit hydraulic* <sup>2</sup>
Front		Ventilated disc brake
Rear		Ventilated disc brake
Parking brake		Mechanical on rear brakes* <sup>1</sup> , Electrical on rear brakes* <sup>2</sup>

\*<sup>1</sup>: 6MT model

\*<sup>2</sup>: CVT model

## SPECIFICATIONS > WRX

### TIRE

Model		2.4 L DOHC turbo
Wheel size		17 × 8J 18 × 8 1/2J
Tire size		235/45 R17 97W 245/40 R18 97Y
Type		Tubeless, steel belted radial

SPECIFICATIONS > WRX

**CAPACITY**

Model		2.4 L DOHC turbo	
		6MT	CVT
Fuel tank		L (US gal, Imp gal)	63 (16.6, 13.9)
Engine oil	Total capacity (at overhaul)	L (US qt, Imp qt)	5.55 (5.9, 4.9)
	When replacing engine oil and oil filter	L (US qt, Imp qt)	4.5 (4.8, 4.0)
	When replacing engine oil only	L (US qt, Imp qt)	4.3 (4.5, 3.8)
TRANSMISSION GEAR OIL	L (US qt, Imp qt)	3.3 (3.5, 2.9)	—
CVTF	L (US qt, Imp qt)	—	11.64 — 12.14 (12.303 — 12.832, 10.224 — 10.684) * <sup>1</sup> , 11.98 — 12.48 (12.663 — 13.191, 10.544 — 10.984) * <sup>2</sup>
Front differential gear oil	L (US qt, Imp qt)	—	1.15 — 1.25 (1.216 — 1.321, 1.012 — 1.100)
Rear differential gear oil	L (US qt, Imp qt)	0.8 (0.85, 0.70)	
Engine coolant	L (US qt, Imp qt)	8.5 (9.0, 7.5)	8.7 (9.2, 7.7)

\*<sup>1</sup>: Model without CVTF cooler (air cool)

\*<sup>2</sup>: Model with CVTF cooler (air cool)

**SPECIFICATIONS > WRX**

**WEIGHT**

Model		Sedan						
		2.4 L DOHC turbo						
		WRX base			WRX base ES	WRX Prm A		
		6MT			CVT	6MT		
OP code		U4	C0	C0 (Mexico )	U4	U4	C0	
		XD	BD	XD	XD	BS	BQ	
Curb weight (C.W.)	Total	kg (lb)	1,496 (3,297)	1,515 (3,340)	1,515 (3,340)	1,557 (3,431)	1,506 (3,320)	1,525 (3,360)
	Front	kg (lb)	904 (1,991)	900 (1,984)	900 (1,984)	958 (2,110)	910 (2,005)	906 (1,996)
	Rear	kg (lb)	592 (1,306)	615 (1,356)	615 (1,356)	599 (1,321)	596 (1,315)	619 (1,364)
Gross vehicle weight (G.V.W.)		kg (lb)	2,100 (4,620)	2,100 (4,620)	2,100 (4,620)	2,100 (4,620)	2,100 (4,620)	2,100 (4,620)
Gross axle weight (G.A.W.)	Front	kg (lb)	1,140 (2,508)	1,140 (2,508)	1,140 (2,508)	1,140 (2,508)	1,140 (2,508)	1,140 (2,508)
	Rear	kg (lb)	1,100 (2,424)	1,100 (2,424)	1,100 (2,424)	1,100 (2,424)	1,100 (2,424)	1,100 (2,424)
Option	Genuine leather seat		-	-	-	-	-	-
	RECARO seat		-	-	-	-	-	-
	Cold weather package		-	○	-	-	○	○
	Advanced package		-	-	-	-	-	-
	Standard audio		○	○	○	○	-	○
	High grade audio		-	-	-	-	○	-
	Navigation system		-	-	-	-	-	-
	Telematics		-	-	-	-	○	-
	Sunroof		-	-	-	-	-	-
Spoiler		-	-	-	-	○	○	

Model		Sedan					
		2.4 L DOHC turbo					
		WRX Prm B		WRX Prm ES			
		6MT		CVT			
OP code		U4	C0	U4	C0		
		BH	EH	BS	BQ	EH	
Curb weight (C.W.)	Total	kg (lb)	1,527 (3,347)	1,547 (3,391)	1,569 (3,457)	1,587 (3,499)	1,601 (3,530)
	Front	kg (lb)	921 (2,018)	917 (2,011)	965 (2,126)	960 (2,117)	967 (2,132)
	Rear	kg (lb)	606 (1,329)	630 (1,380)	604 (1,331)	627 (1,382)	634 (1,398)
Gross vehicle weight (G.V.W.)		kg (lb)	2,100 (4,620)	2,100 (4,620)	2,100 (4,620)	2,100 (4,620)	2,100 (4,620)
Gross axle weight (G.A.W.)	Front	kg (lb)	1,140 (2,508)	1,140 (2,508)	1,140 (2,508)	1,140 (2,508)	1,140 (2,508)
	Rear	kg (lb)	1,100 (2,424)	1,100 (2,424)	1,100 (2,424)	1,100 (2,424)	1,100 (2,424)
Option	Genuine leather seat		-	-	-	-	-
	RECARO seat		-	-	-	-	-
	Cold weather package		○	○	○	○	○
	Advanced package		-	○	-	-	○
	Standard audio		-	-	-	○	-
	High grade audio		○	○	○	-	○
	Navigation system		-	-	-	-	-
	Telematics		○	○	○	-	○
	Sunroof		○	○	-	-	○
	Spoiler		○	○	○	○	○

Model		Sedan					
		2.4 L DOHC turbo					
		WRX Ltd					
		6MT					
OP code		U4		C0	C0 (Mexico)		
		PH	QG	QG	XE	HF	
Curb weight (C.W.)	Total	kg (lb)	1,529 (3,370)	1,538 (3,390)	1,558 (3,434)	1,527 (3,366)	1,549 (3,412)
	Front	kg (lb)	917 (2,022)	923 (2,034)	919 (2,026)	901 (1,986)	914 (2,013)
	Rear	kg (lb)	612 (1,348)	615 (1,356)	639 (1,408)	626 (1,380)	635 (1,399)
Gross vehicle weight (G.V.W.)		kg (lb)	2,100 (4,620)	2,100 (4,620)	2,100 (4,620)	2,100 (4,620)	2,100 (4,620)
Gross axle weight (G.A.W.)	Front	kg (lb)	1,140 (2,508)	1,140 (2,508)	1,140 (2,508)	1,140 (2,508)	1,140 (2,508)
	Rear	kg (lb)	1,100 (2,424)	1,100 (2,424)	1,100 (2,424)	1,100 (2,424)	1,100 (2,424)
Option	Genuine leather seat		○	○	○	-	○
	RECARO seat		-	-	-	-	-
	Cold weather package		○	○	○	-	-
	Advanced package		-	○	○	-	○
	Standard audio		-	-	-	-	-
	High grade audio		○	-	-	○	○
	Navigation system		-	○	○	-	-
	Telematics		○	○	○	-	-
	Sunroof		○	○	○	-	○
Spoiler		○	○	○	-	○	

Model		Sedan							
		2.4 L DOHC turbo							
		WRX Ltd ES				WRX GT ES			
		CVT				CVT			
OP code		U4		C0	C0 (Mexico )	U4	C0 (Mexico)		
		PH	QG	QG	HF	OG	RF	RC	
Curb weight (C.W.)	Total	kg (lb)	1,591 (3,508)	1,601 (3,529)	1,621 (3,572)	1,611 (3,551)	1,604 (3,534)	1,614 (3,556)	1,622 (3,576)
	Front	kg (lb)	972 (2,143)	978 (2,156)	974 (2,147)	968 (2,134)	980 (2,159)	970 (2,137)	975 (2,149)
	Rear	kg (lb)	619 (1,365)	623 (1,373)	647 (1,425)	643 (1,417)	624 (1,375)	644 (1,419)	647 (1,427)
Gross vehicle weight (G.V.W.)		kg (lb)	2,100 (4,620)	2,100 (4,620)	2,100 (4,620)	2,100 (4,620)	2,100 (4,620)	2,100 (4,620)	2,100 (4,620)
Gross axle weight (G.A.W.)	Front	kg (lb)	1,140 (2,508)	1,140 (2,508)	1,140 (2,508)	1,140 (2,508)	1,140 (2,508)	1,140 (2,508)	1,140 (2,508)
	Rear	kg (lb)	1,100 (2,424)	1,100 (2,424)	1,100 (2,424)	1,100 (2,424)	1,100 (2,424)	1,100 (2,424)	1,100 (2,424)
Option	Genuine leather seat		○	○	○	○	-	-	-
	RECARO seat		-	-	-	-	○	○	○
	Cold weather package		○	○	○	-	○	-	-
	Advanced package		-	○	○	○	○	○	○
	Standard audio		-	-	-	-	-	-	-
	High grade audio		○	-	-	○	-	○	-
	Navigation system		-	○	○	-	○	-	○
	Telematics		○	○	○	-	○	-	-
	Sunroof		○	○	○	○	○	○	○
	Spoiler		○	○	○	○	○	○	○

# PRECAUTION

*PC*

---

1. Precaution

## CAUTION

---

Please clearly understand and adhere to the following general precautions for environmental protection and to avoid minor or serious injury to the person doing the work or people in the area.

### 1. VEHICLE DYNAMICS CONTROL (VDC)

Handle the VDC as a total system. Do not disassemble or attempt to repair individual parts. Follow the directions in this manual when performing maintenance on the VDCCM&H/U. When parts other than those specified are disassembled, it is possible that the VDC system will not operate when needed or cause it to operate incorrectly and result in injury.

### 2. ELECTRONIC PARKING BRAKE

- Handle the electronic parking brake as a total system.
- When handling the parts, be sure to observe the cautions and procedures described in the related section. When non-disassembly parts are disassembled or repaired, it is possible that the electronic parking brake will not operate when needed or cause it to operate incorrectly and result in injury.

### 3. BRAKE FLUID

If brake fluid gets in your eyes or on your skin, do the following:

- Wash your eyes and seek immediate medical attention.
- Wash your skin with soap and then rinse thoroughly with water.

### 4. RADIATOR FAN

The radiator fan may rotate without warning, even when the engine is not ON. Do not place your hand, cloth, tools or other items near the fan at any time.

### 5. ROAD TEST

Always conduct road tests in accordance with traffic rules and regulations to avoid bodily injury and interrupting traffic.

### 6. AIRBAG

To prevent bodily injury from unexpected deployment of airbags and unnecessary maintenance, follow the instructions in this manual when performing maintenance on the airbag components and nearby, around front of the vehicle (radiator panel, front wheel apron, front side frame, bumper face front, hood COMPL front, fender front), around side of the vehicle (panel COMPL door front, panel COMPL door rear, center pillar, rear fender panel, spoiler assembly side sill, wheel apron rear), around rear of the vehicle (rear seat cushion, rear floor pan, sub frame assembly rear) and the airbag wiring harnesses and nearby. To prevent unexpected deployment, turn the ignition switch to OFF and disconnect the ground terminal from the battery sensor, then wait at least 90 seconds to discharge electricity before starting work. Removing or installing the components or the connectors with the ignition switch ON will electrically impair them.

### 7. AIRBAG AND SEAT BELT PRETENSIONER DISPOSAL

To prevent bodily injury from unexpected airbag deployment, do not dispose the airbag modules or seat belt pretensioner in the same way as other waste. Follow all government regulations concerning disposal

of refuse.

## **8. AIRBAG MODULE**

Adhere to the following when handling and storing the airbag module to prevent bodily injury from unexpected deployment.

- Do not hold the harnesses or connectors to carry the module.
- Do not face the bag in the direction that it opens towards yourself or other people.
- Do not face the bag in the direction that it opens towards the floor or walls.

## **9. AIRBAG SPECIAL TOOL**

To prevent unexpected deployment, always use special tools for the area where the operation with special tools are required.

## **10. WINDOW**

Always wear protective goggles when working around any glass to prevent glass fragments from damaging your eyes.

## **11. WINDOW ADHESIVE**

Always use the recommended or equivalent adhesive when attaching the glass. Prevent adhesive removal or the glass from falling off, resulting in accidents and injury.

## **12. OIL**

When handling oil, adhere to the following to prevent unexpected accident.

- Prepare a container and cloth to prevent scattering of oil when performing work where oil can be spilled. If the oil spills, wipe it off immediately to prevent from penetrating into floor or flowing out for environmental protection.
- Follow all government and local regulations concerning disposal of refuse when disposing.

## **13. FUEL**

When handling and storing fuel, adhere to the following to prevent unexpected accidents.

- The fuel is flammable. Do not put it close to a fire or spark.
- Prepare a container and cloth to prevent scattering of fuels when performing work where fuels can be spilled. If the oil spills, wipe it off immediately to prevent from penetrating into floor or flowing out for environmental protection.
- Follow all government and local regulations concerning disposal of refuse when disposing.

## **14. ENGINE COOLANT**

When handling engine coolant, adhere to the following to prevent unexpected accidents.

- Never remove the radiator cap since engine coolant may blow out when it is hot.
- Prepare a container and cloth to prevent scattering of engine coolant when performing work where engine coolant can be spilled. If the oil spills, wipe it off immediately to prevent from penetrating into floor or flowing out for environmental protection.
- Follow all government and local regulations concerning disposal of refuse when disposing.

## **15. AIR CONDITIONER REFRIGERANT**

In order to prevent from global warming, avoid releasing air conditioner refrigerant into the atmosphere. Using a refrigerant recovery system, discharge and recycle it.

## 16. REMOVAL AND INSTALLATION OPERATION OF HOSES, ETC.

### 1. BEFORE THE REMOVAL AND INSTALLATION OPERATION OF HOSES, ETC.

- If you keep using the damaged or deformed hose, it results bleeds or leakage of the fat adheres or disconnection of the hose. Be careful not to spill fat adheres on exhaust pipes, etc. during maintenance to prevent emitting smoke or causing fires.
- Perform the operation with the hose removed. If the operation is performed without removing the hose, it may damage inner surface of the hose.

### 2. REMOVAL AND INSTALLATION OPERATION OF HOSES, ETC. DURING THE INSPECTION

- **Follow the instructions below when removing hose.**
  - When removing the hose, do not use a pointed hose remover (hose plucker). Inner portion of the hose can be damaged.

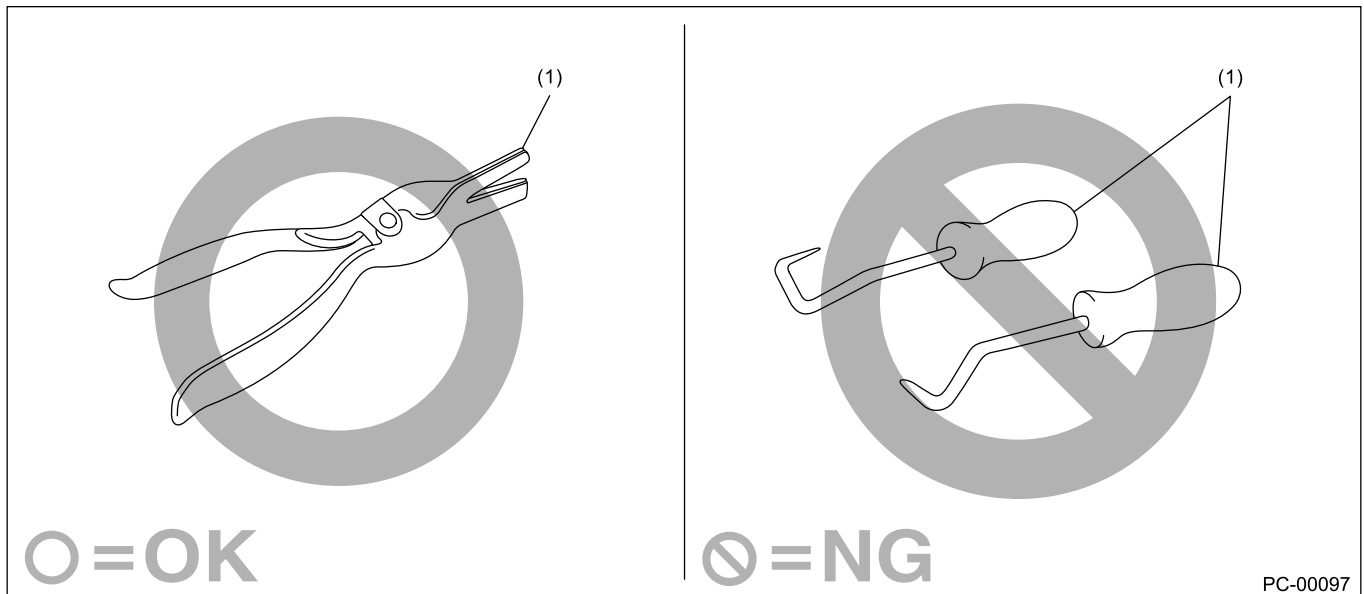

(1) Hose remover

- When removing the hose using pliers, be sure to cover the hose with cloth and rotate the hose slightly to extract straight.
- **If you keep using the hose, perform the inspection below and replace the hose with a new part if faulty.**
  - Replace the hose with a new part if it rides over the stay or the top of spool.

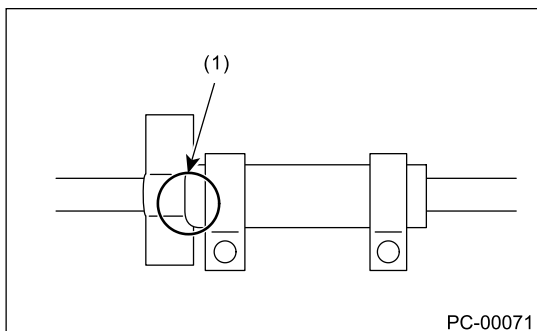

(1) Hose rides over the stay

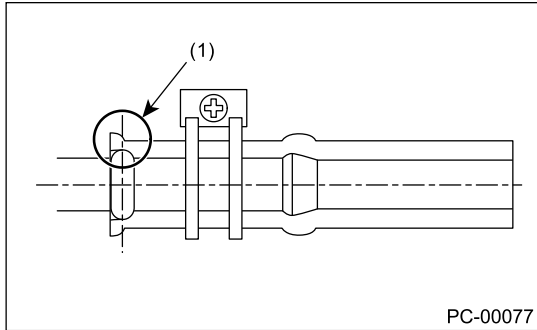

(1) Hose rides over the top of spool

- Check if the surface and the inner surface of the hose are damaged, cracked, bend, hardened, softened, swelled, peeled or deformed due to the adherence or the entry of the foreign matter by bending the hose. Replace with the new part if faulty.
- **Follow the instructions below during installation.**
  - Check carefully for assembling position.
  - Never use lubricants.
  - Insert the hose to the specified position (stopper or spool) securely. (The hose should stop at the position between the spool top and root.)

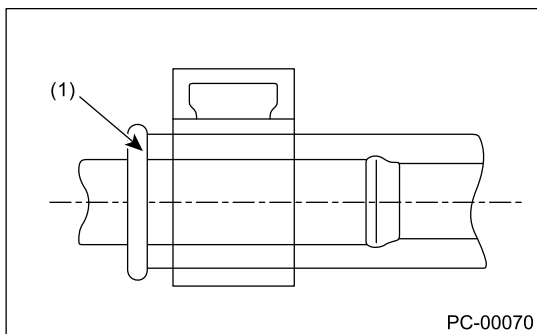
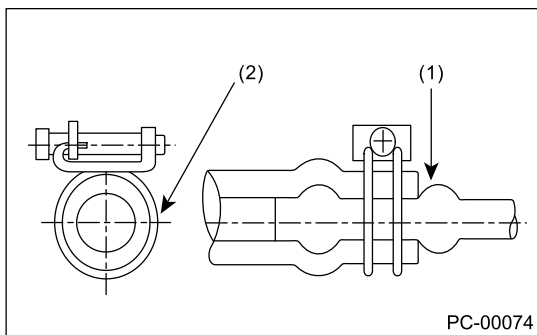

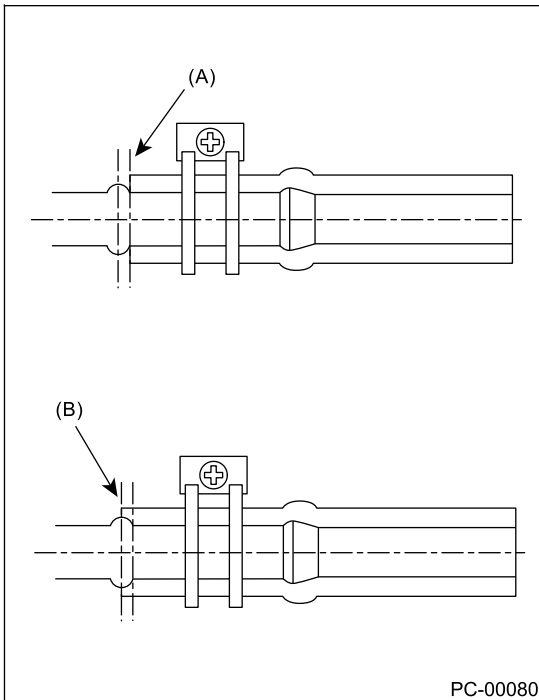

(1) Push against the spool. (Insert the hose and prevent it from becoming wrinkled.)

(2) Tighten the hose clamp completely.

(A) OK position (bottom of spool)

(B) OK position (top of spool)

- Check if the position, direction and hose layout of the hose clamp are correct. (Check if the position, direction, length and the gap around are correct, or if it is different from the condition before the work)
- After the installation, check that the hose is installed securely and there is no leakage. (Check if it is fixed securely with the clamp)
- **For hose clips and hose clamps, perform the inspection below and replace them with a new part if faulty.**
  - Check for deformation, rust, damage or foreign matters.
  - For hose clip, check if it works and has clamping force.
  - For hose clamp, check if it can tighten screw, not ovalized or the screw is not damaged.
- **For hose pipes, perform the inspection below and replace with a new part if faulty.**

Check if the pipe is not damaged, rusted, peeled (peeled plates included), covered with foreign matter, bent, compressed or cracked.
- **For the parts below, replaces with a new part when the hose is removed or the installation position is changed.**

CVTF oil cooler hose, engine oil hose, fuel hose (delivery) (except for those with quick connector)

## 17. HANDLING PRECAUTIONS FOR SILICONE-CONTAINING SPRAY

When silicone contained in the lubricant, rust inhibitor or glazing agent adheres to the electrical contact of the relay or switch, non-conducting silica dioxide (SiO<sub>2</sub>) film will be formed, which may lead to poor

continuity. Therefore, the following precautions must be observed when using the silicone-containing spray.

- Never spray directly to the electrical equipment.
- When using the spray close to the electrical equipment, always put the cover on it. Be sure to put the cover on the electrical equipment especially when using the spray to the locations shown in the figure below and their surrounding areas.

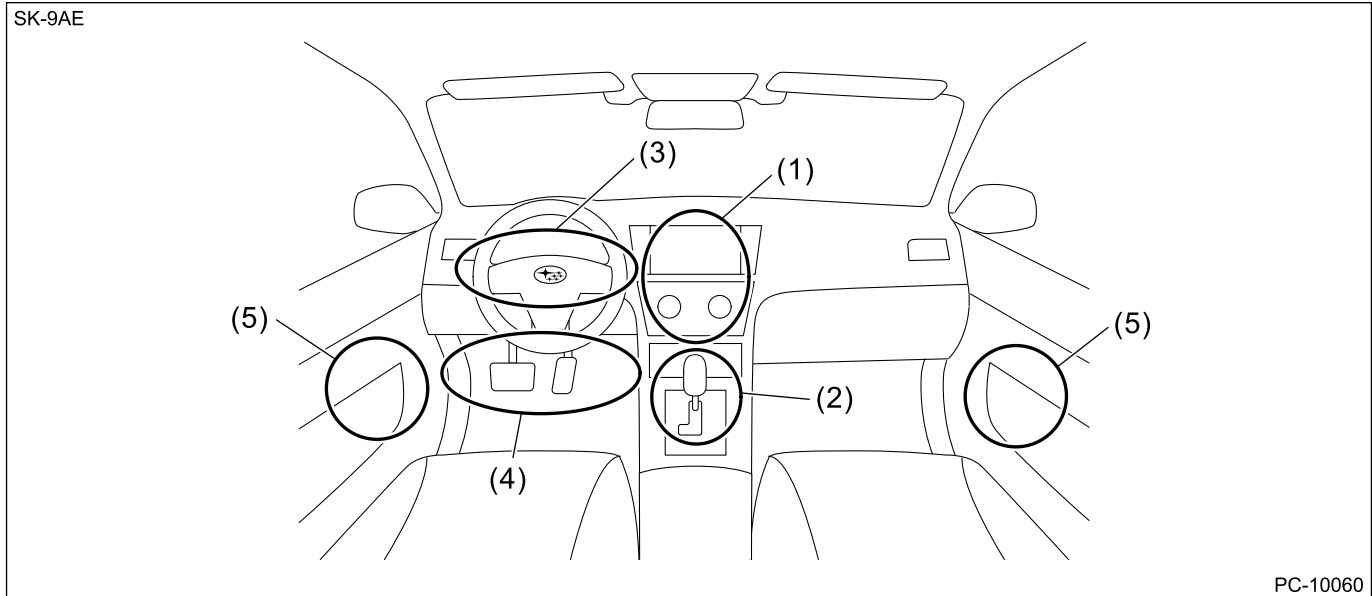

- |   |   |   |
|---|---|---|
| (1) Center information display ASSY   | (3) Switch ASSY combination, satellite switch, paddle shift, switch ASSY steering (MID) | (5) Switch power window main, switch power window sub front |
| (2) Solenoid unit & "P range" switch, switch ASSY EPB, manual mode switch, switch ASSY hand brake | (4) Stop light switch ASSY, clutch start switch, clutch switch                          |   |

- If the residual silicone remains in the vicinity of the electrical equipment after the spray has been used, the vaporized silicone stands around the electrical equipment and it may adhere to electrical contact. After using the spray, be sure to wipe the silicone off with a cloth.
- Even when using the spray to the place away from the electrical equipment, the droplet of the spray may be splashed to the periphery. Use as small amount of spray as possible, and take care not to splash the silicone to the periphery.

**Note:**

The "silicone" used in this section refers to silicon polymer.

## 18. CHECK WINDSHIELD GLASS INCLUDING PROHIBITED AREA FOR MODEL WITH EyeSight

### 1. PROHIBITED AREA FOR STICKER ATTACHMENT AND INSPECTION

Do not attach stickers in the prohibited area on the windshield as follows. Clean the windshield glass if oil film, dirt or fogging that obstructs the visibility of each camera is found in the prohibited area, and repair or replace if the windshield is scratched. The vehicle inspection label that is required to be attached on the windshield should be attached on the specified position. If stickers or windshield-

related issues adversely affect the visibility of the camera, the function of EyeSight may not work properly.  [Ref. to EyeSight>EyeSight System>PROCEDURE > CLEANING.](#)

**Caution:**

- **Do not attach any foreign matter such as oil and fluid.**
- **As dirt on the front glass (inner side) in front of EyeSight camera may affect the recognition performance, be sure to clean the glass.**
- **Be sure to remove the stereo camera and lens hood before starting the work, since the lens portion and lens hood may receive dirt or may be damaged due to impact applied during cleaning.**
- **When replacing the windshield glass, be sure to replace it with the Subaru genuine windshield glass specially designed for EyeSight.**
- **If the glass is removed or replaced, always perform the stereo camera adjustment and inspection, and the heater heating and cooling fan drive test.**

**Note:**

**The prohibited area shown in the figure indicates the range for the SUBARU genuine accessory installation.**

The illustration below shows from outside of the compartment.

VB-\*BU

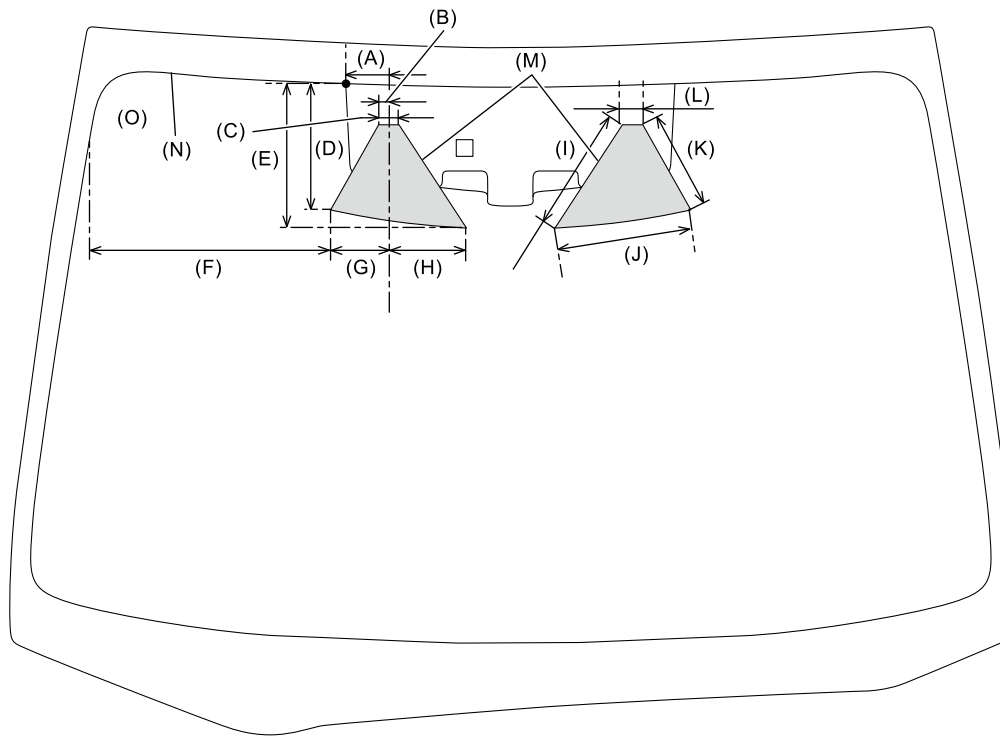

PC-10240

(A) 60.0 mm (2.36 in)	(F) 345.0 mm (13.58 in)	(K) 141.0 mm (5.55 in)
(B) 15.0 mm (0.59 in)	(G) 85.0 mm (3.35 in)	(L) 30.0 mm (1.18 in)
(C) 30.0 mm (1.18 in)	(H) 110.0 mm (4.33 in)	(M) Prohibited area
(D) 180.0 mm (7.09 in)	(I) 175.0 mm (6.89 in)	(N) Ceramic line
(E) 205.0 mm (8.07 in)	(J) 195.0 mm (7.68 in)	(O) Vehicle inspection label

**2. PROHIBITED AREA OF DASHBOARD AND INSPECTION**

Do not stick or attach the aftermarket parts on the prohibited area (F) shown as follows. If abnormality of the function occurs due to light reflection or glass reflection, even though placed outside the prohibited area, change the attachment position or installation position. Placing a navigation system, ETC device or an object on the dashboard will cause reflection on the windshield glass, affecting the recognition of the stereo camera, thus causing the function not to operate correctly.

- Front view

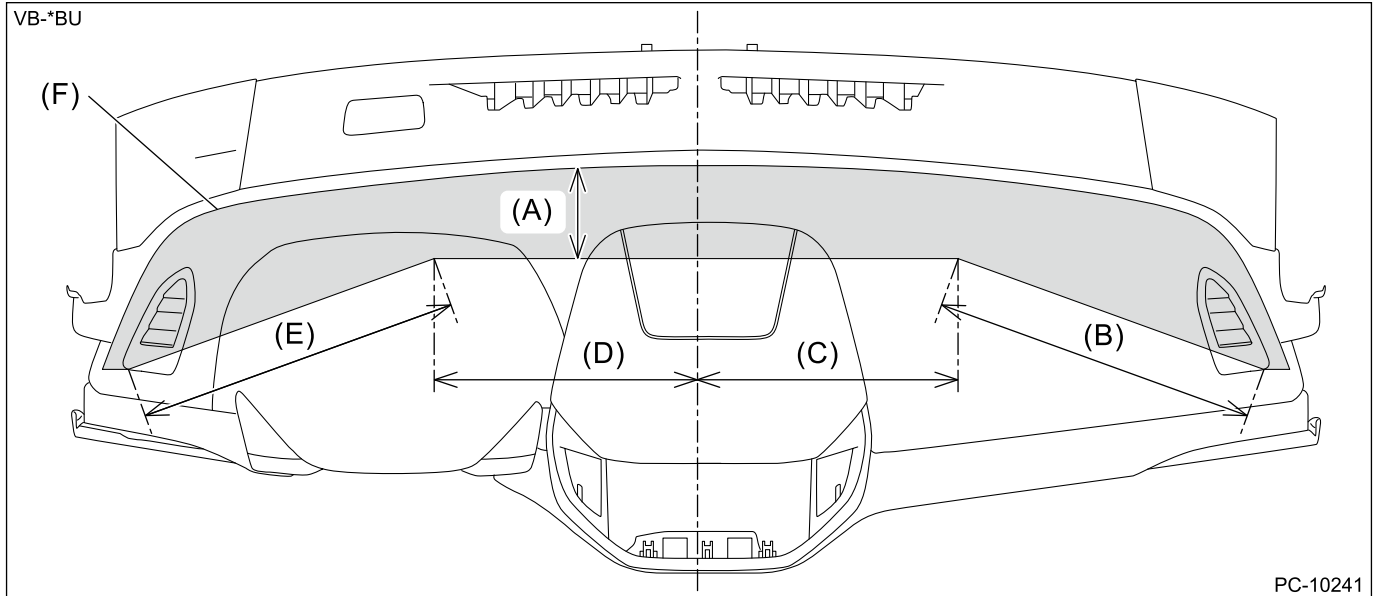

- |                         |                         |                                  |
|-------------------------|-------------------------|----------------------------------|
| (A) 110.0 mm (4.33 in)  | (C) 300.0 mm (11.81 in) | (E) 400.0 mm (15.75 in)          |
| (B) 400.0 mm (15.75 in) | (D) 300.0 mm (11.81 in) | (F) Prohibited area of dashboard |

### 3. PROHIBITED AREA FOR REPAIR AND INSPECTION

The illustration below shows from the passenger compartment.

If the damage is found in the glass repair prohibited area, always replace the glass. Damage in the prohibited area can affect the recognition of the stereo camera even if it is repaired, and thereby EyeSight function may not operate properly.

VB-\*BU

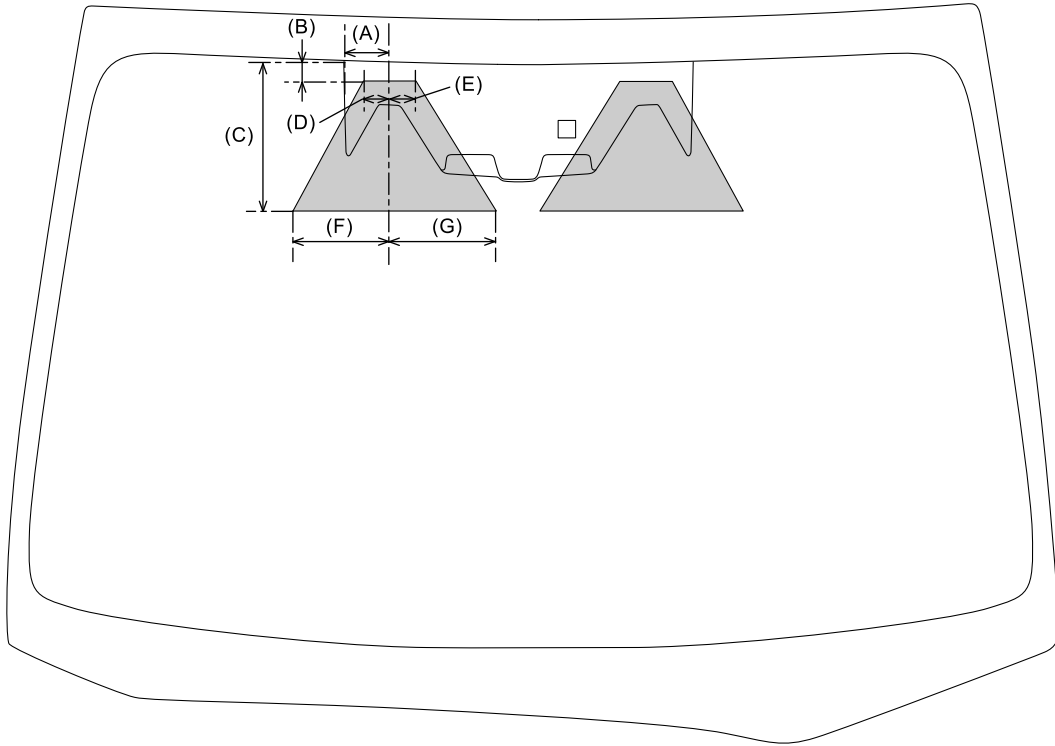

PC-10242

(A) 60.0 mm (2.36 in)

(D) 35.0 mm (1.38 in)

(G) 145.0 mm (5.71 in)

(B) 25.0 mm (0.98 in)

(E) 35.0 mm (1.38 in)

(C) 200.0 mm (7.87 in)

(F) 130.0 mm (5.12 in)

# REPAIR CONTENTS

*RC*

---

1. Repair Contents

## REPAIR CONTENTS

### NOTE

This section describes basic points that the service operator must understand before performing the service operation.

### 1. APPEARANCE

- Always wear clean work clothing.
- Wear a work cap and protective shoes during work.

### 2. PROTECTION OF VEHICLE UNDER MAINTENANCE AND PREPARATION OF TOOLS/EQUIPMENT

- Prior to starting service work, protect the vehicle body. (Grille cover, fender cover, seat cover and floor mat cover, etc.)
- Before performing the service operation, prepare tools, equipment, container box, grease and cloth etc.

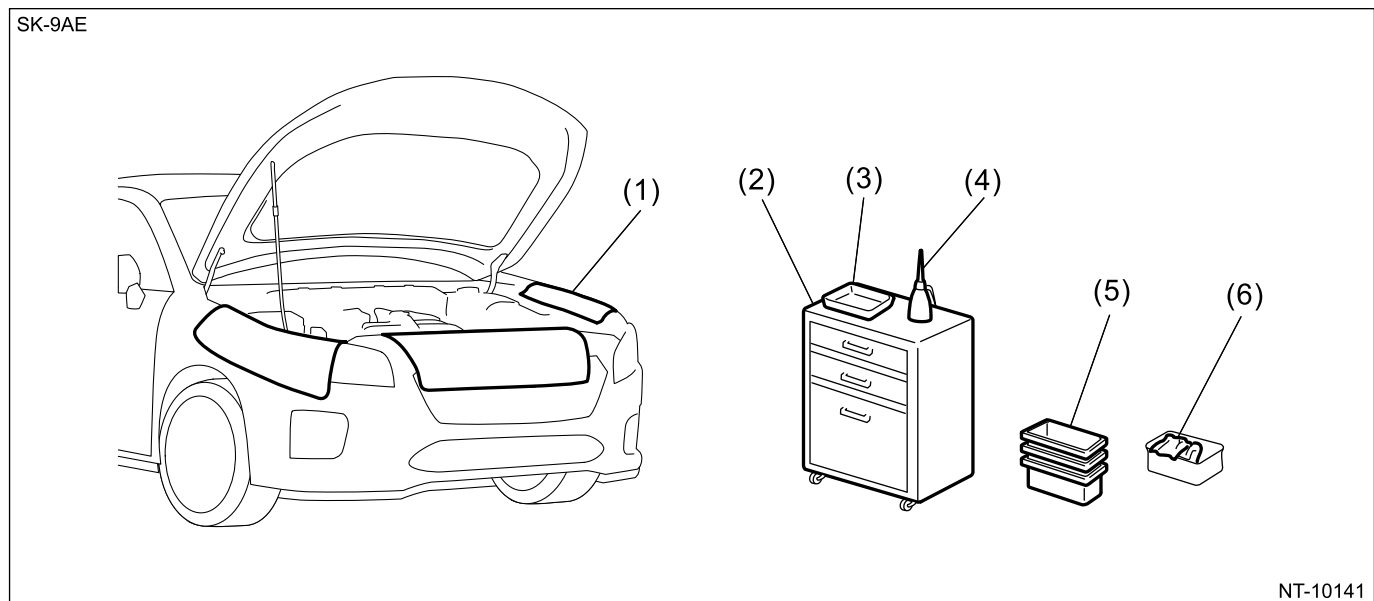

(1) Fender cover

(2) Tools/equipment case

(3) Tray

(4) Oil

(5) Container box

(6) Cloth

### 3. SAFETY

- Before work, set the wheel stoppers to secure the vehicle.
- When performing work by multiple workers, call to each other to make sure that service operation is performed safely.
- Ventilate the room when starting the engine.
- When performing the service operation of high-temperature parts like muffler, or rotating parts like fan and other movable parts, be careful not to get burned or injured.
- For the jack-up and lift up, set the tool to the proper location to support the vehicle correctly. And use the safety device properly when lifting up.

### 4. SERVICE OPERATION



- By identifying the vehicle problems thoroughly before work, service operation will be performed effectively.
- Before removing parts, confirm the installation condition or the damage of the parts.
- To reinstall parts properly, leave a note of the condition before work as necessary.
- For a part which needs positioning, take appropriate action such as putting alignment marks.
- For a removed part, clean it as necessary and check for damage and defect before installation. If a part is damaged or does not work properly, replace it with a new part.
- Removing or installing the components or the connectors with the ignition switch ON will electrically impair them.
- Reconnect the harness connectors for each control module one or more minutes after disconnecting them.
- For installation of the bolt, nut, and screws, use tools suitable for each dimension, and use them vertically and securely.

## 5. SERVICE PARTS





- A removed part must be organized to avoid mixing up with similar parts. When same parts are used in multiple locations, such as pistons in engine, manage the parts by using labels with cylinder No. so that the parts are not installed to the wrong location.
- Always replace non-reusable parts such as gasket and O-ring with new parts.
- After work, have a customer confirm the replaced part.
- Use genuine parts for maximum performance and maintenance when conducting repairs. SUBARU CORPORATION will not be responsible for poor performance resulting from the use of parts except for genuine parts.







## 6. SETTING OPERATION FOR PARTS REPLACEMENT, REMOVAL/INSTALLATION

Operation list

Main replacement part / operation	Necessary operation	Phenomenon when not performed / disabled function	Reference
<ul style="list-style-type: none"> <li>• TCM</li> <li>• Transmission body</li> <li>• Control valve body</li> </ul>	<ol style="list-style-type: none"> <li>1. Clear AT learning value</li> <li>2. AT learning mode</li> <li>3. Module registration (when TCM is replaced)</li> </ol>	<ul style="list-style-type: none"> <li>• Abrupt engine increase</li> <li>• Excessive shift shock</li> </ul>	<p> <a href="#">Ref. to CONTINUOUSLY VARIABLE TRANSMISSION (TR690)&gt;AT learning&gt;PROCEDURE.</a></p> <p> <a href="#">Ref. to COMMON (DIAGNOSTICS)&gt;Unit Registration.</a></p>
<ul style="list-style-type: none"> <li>• VDC control module and hydraulic control unit (VDCCM&amp;H/U)</li> <li>• Steering angle sensor</li> </ul>	<ol style="list-style-type: none"> <li>1. VDC sensor midpoint setting</li> <li>2. Parameter selection and registration (when</li> </ol>	<ul style="list-style-type: none"> <li>• VDC system does not operate normally (Warning light illuminates)</li> </ul>	<p> <a href="#">Ref. to VEHICLE DYNAMICS CONTROL</a></p>

Main replacement part / operation	Necessary operation	Phenomenon when not performed / disabled function	Reference
<ul style="list-style-type: none"> <li>Column assembly steering</li> <li>Steering gearbox assembly</li> <li>Steering wheel</li> <li>Universal joint assembly steering</li> <li>Wheel alignment adjustment</li> <li>For other parts replacement, refer to the operation and adjustment procedures for each item.</li> </ul>	<ul style="list-style-type: none"> <li>replacing VDCCM&amp;H/U)</li> <li>3. Lane keep assist learning value clear (when adjusting wheel alignment)</li> <li>4. Module registration</li> </ul>	<ul style="list-style-type: none"> <li>Steering warning light</li> <li>EPS control</li> <li>Difference of steering effort between right and left</li> <li>EyeSight does not operate normally</li> </ul>	<p><a href="#">(VDC)&gt;VDC Control Module and Hydraulic Control Unit (VDCCM&amp;H/U). &gt;ADJUSTMENT &gt; VDC SENSOR MIDPOINT SETTING MODE.</a></p> <p> <a href="#">Ref. to VEHICLE DYNAMICS CONTROL (VDC)&gt;VDC Control Module and Hydraulic Control Unit (VDCCM&amp;H/U). &gt;MAINTENANCE MODE.</a></p> <p> <a href="#">Ref. to EyeSight (DIAGNOSTICS)&gt;Work Support.</a></p> <p> <a href="#">Ref. to COMMON (DIAGNOSTICS)&gt;Unit Registration&gt; OPERATION.</a></p>
<ul style="list-style-type: none"> <li>Auto headlight beam leveler CM</li> </ul>	<ul style="list-style-type: none"> <li>1. Auto headlight beam leveler system initialization/reinitialization</li> </ul>	<ul style="list-style-type: none"> <li>AUTO HEADLIGHT BEAM LEVELER SYSTEM</li> </ul>	<p> <a href="#">Ref. to LIGHTING SYSTEM&gt;Auto Headlight Beam Leveler System&gt;PROCEDURE.</a></p>
<ul style="list-style-type: none"> <li>Regulator &amp; motor assembly front (RH, LH)</li> </ul>	<ul style="list-style-type: none"> <li>1. Power window system initialization</li> </ul>	<ul style="list-style-type: none"> <li>Door glass automatic open/close function</li> <li>Auto-reverse function</li> </ul>	<p> <a href="#">Ref. to GLASS/WINDOWS/MIRRORS</a></p>

Main replacement part / operation	Necessary operation	Phenomenon when not performed / disabled function	Reference
<ul style="list-style-type: none"> <li>Regulator &amp; motor assembly rear (RH, LH)</li> <li>Glass assembly front door (RH, LH), glass assembly rear door (RH, LH), sash assembly partition (RH, LH), sash assembly front door LWR (RH, LH) or sash assembly rear door partition</li> <li>Running channel front door (RH, LH)</li> <li>Running channel rear door (RH, LH)</li> </ul>		<ul style="list-style-type: none"> <li>Operation after key OFF (ignition switch OFF)</li> <li>Remote control of seats with driver's seat switch</li> </ul>	<a href="#">&gt;Power Window System&gt;OPERATION.</a>
<ul style="list-style-type: none"> <li>Body integrated unit</li> </ul>	1. Customize	<ul style="list-style-type: none"> <li>Poor operation of each function</li> </ul>	 <a href="#">Ref. to BODY CONTROL(DIAGNOSTICS)&gt;Customize.</a>
<ul style="list-style-type: none"> <li>Combination meter</li> </ul>	1. Variant work	<ul style="list-style-type: none"> <li>Poor operation of each function</li> </ul>	 <a href="#">Ref. to INSTRUMENTATION/DRIVER INFO&gt;Combination Meter&gt;REPLACEMENT &gt; VARIANT WORK.</a>
<ul style="list-style-type: none"> <li>Stereo camera</li> </ul>	<ol style="list-style-type: none"> <li>Camera adjustment and inspection</li> <li>Module registration</li> </ol>	<ul style="list-style-type: none"> <li>EyeSight does not operate normally</li> </ul>	 <a href="#">Ref. to EyeSight&gt;Camera Adjustment, Inspection&gt;PROCEDURE.</a>  <a href="#">Ref. to COMMON (DIAGNOSTICS)&gt;Unit Registration&gt;OPERATION.</a>
<ul style="list-style-type: none"> <li>Windshield glass</li> </ul>	1. Camera adjustment and inspection	<ul style="list-style-type: none"> <li>EyeSight does not operate normally</li> </ul>	 <a href="#">Ref. to EyeSight&gt;Cam</a>

Main replacement part / operation	Necessary operation	Phenomenon when not performed / disabled function	Reference
			<a href="#">era Adjustment, Inspection&gt;PROCEDURE.</a>
<ul style="list-style-type: none"> <li>• Lens hood</li> </ul>	<ol style="list-style-type: none"> <li>1. Heater heating and cooling fan drive test</li> </ol>	<ul style="list-style-type: none"> <li>• EyeSight does not operate normally</li> </ul>	 <a href="#">Ref. to EyeSight&gt;Lens Hood&gt;INSPECTION &gt; HEATER HEATING AND COOLING FAN DRIVE TEST.</a>
<ul style="list-style-type: none"> <li>• Data communication module (DCM)</li> </ul>	<ol style="list-style-type: none"> <li>1. Server registration (Comm Check)</li> <li>2. Immobilizer system registration</li> </ol>	<ul style="list-style-type: none"> <li>• Poor operation of each function</li> </ul>	 <a href="#">Ref. to ENTERTAINMENT &amp; MONITORING &gt;Telematics System&gt;OPERATION &gt; REGISTRATION (COMM CHECK).</a>
<ul style="list-style-type: none"> <li>• Motor assembly</li> <li>• Lid assembly</li> </ul>	<ol style="list-style-type: none"> <li>1. Initialize operation</li> </ol>	<ul style="list-style-type: none"> <li>• Poor operation of each function</li> </ul>	 <a href="#">Ref. to SUNROOF/T-TOP/CONVERTIBLE TOP (SUNROOF)&gt;Sunroof Control System&gt;OPERATION.</a>
<ul style="list-style-type: none"> <li>• Electric brake booster</li> <li>• Engine control module (ECM)</li> <li>• Central gateway CM</li> </ul>	<ol style="list-style-type: none"> <li>1. Module registration</li> </ol>	<ul style="list-style-type: none"> <li>• Poor operation of each function</li> </ul>	 <a href="#">Ref. to COMMON (DIAGNOSTICS)&gt;Unit Registration&gt;OPERATION.</a>
<ul style="list-style-type: none"> <li>• Passenger's seat</li> <li>• Airbag control module</li> </ul>	<ol style="list-style-type: none"> <li>1. Occupant detection system [Sensor rezero adjustment]</li> </ol>	<ul style="list-style-type: none"> <li>• Poor operation of each function</li> </ul>	 <a href="#">Ref. to AIRBAG(DIAGNOSTICS)&gt;Rezero.</a>
<ul style="list-style-type: none"> <li>• Steering roll connector removing/installing</li> </ul>	<ol style="list-style-type: none"> <li>1. Alignment of steering roll connector center</li> </ol>	<ul style="list-style-type: none"> <li>• Poor operation of each function</li> </ul>	 <a href="#">Ref. to AIRBAG</a>

Main replacement part / operation	Necessary operation	Phenomenon when not performed / disabled function	Reference
	neutral position (when reused)		<a href="#">SYSTEM&gt;Roll Connector&gt;AD JUSTMENT.</a>

**Note:**

For settings or other procedures for immobilizer related part, refer to "REGISTRATION MANUAL FOR IMMOBILIZER".

## 7. BATTERY

### • ACTIONS TO TAKE AFTER REMOVING BATTERY OR DISCONNECTING GROUND TERMINAL OF BATTERY SENSOR

When removing the battery or disconnecting the battery terminal, always be sure to turn the ignition switch to OFF and disconnect the ground terminal from the battery sensor first.

When removing the battery or disconnecting the battery terminal, power supply is cut off and the information stored in the computer memory is volatilized. Therefore, setting information of some devices is initialized to the factory default. The device and functions initialized by removing battery are as follows.

No.	Item	Job contents when connecting battery
1	Center information display (CID)	<ul style="list-style-type: none"> <li>• Clock: Set to the current time.</li> <li>• Audio (settings that the customer set): Set to the contents checked before disconnecting the battery.</li> <li>• Navigation system (settings that the customer set): Time setting is not necessary because the time information is received via GPS.</li> <li>• Navigation system (settings that the customer set): Set the sound and other settings (items that were set in the selection) to the contents checked before disconnecting the battery.</li> <li>• Temperature setting of fully automatic air conditioner (settings that the customer set): Set to the contents checked before disconnecting the battery.</li> </ul>
2	Steering lock system (model with keyless access with push button start)	<p>If the engine does not start, initialize the steering lock system. For the initialization procedure, refer to "Diagnostics with Phenomenon" of "KEYLESS ACCESS WITH PUSH BUTTON START SYSTEM (DIAGNOSTICS)".  <a href="#">Ref. to KEYLESS ACCESS WITH PUSH BUTTON</a></p>

No.	Item	Job contents when connecting battery
		<a href="#">START(DIAGNOSTICS)&gt;Diagnostics with Phenomenon&gt;INSPECTION &gt; ENGINE DOES NOT START.</a>
3	EyeSight	Set to the contents checked before disconnecting the battery.
4	Electronic throttle system	Turn the ignition switch to ON, wait for 10 seconds or more, and start the engine.
5	Engine control system	<ul style="list-style-type: none"> <li>Let the engine run at idle until it fully warms up (the radiator fan turns 2 times or more) under no electrical load condition.</li> <li>After connecting the ground terminal to the battery sensor, wait for 10 seconds or more and turn the ignition switch to ON.</li> </ul>
6	Telematics	Perform the Bluetooth connection procedure between head unit (without navigation) and smartphone.  <a href="#">Ref. to REPAIR CONTENTS&gt;NOTE &gt; Bluetooth CONNECTION PROCEDURE BETWEEN HEAD UNIT (AUDIO WITHOUT NAVIGATION) AND SMARTPHONE.</a>
7	Some of Diagnostic Trouble Codes (DTC)	—

● **GROUND TERMINAL REMOVAL OR INSTALLATION**

1. Disconnect the ground terminal from battery sensor.

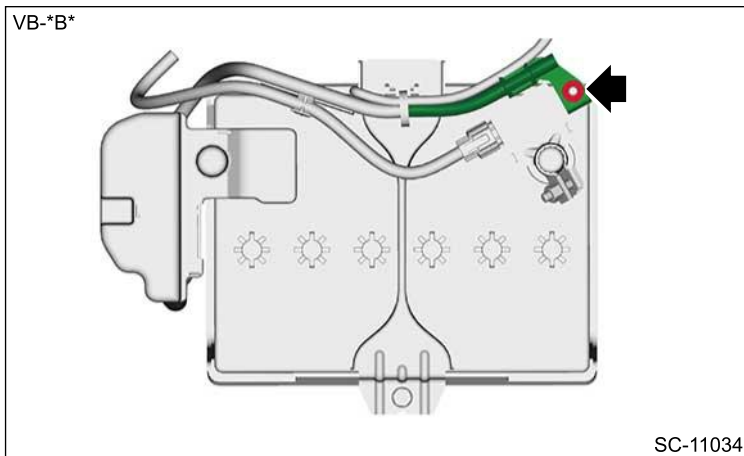

**Note:**

**Open the trunk as necessary before disconnecting the ground terminal from the battery sensor.**

2. Connect the ground terminal to battery sensor.

**Note:**

- Install the battery sensor while holding it by hand to prevent rotating.
- Clean the battery cable terminals and apply anti-rust grease to retard the formation of corrosion.
- Connect the positive terminal of the battery, and then connect the ground terminal to the battery sensor.
- Some DTCs may be detected, so after connecting the ground terminal to the battery sensor, wait for 10 seconds or more and then turn the ignition switch to ON.
- After the battery is installed, initial diagnosis of the electronic throttle control is performed. Wait for 10 seconds or more after turning the ignition switch to ON, and then start the engine.
- For battery replacement procedures, refer to "Battery" of "STARTING/CHARGING SYSTEMS".  Ref. to STARTING/CHARGING SYSTEMS(H4DOTC)>Battery.

**Tightening torque:**

7.5 N·m (0.8 kgf-m, 5.5 ft-lb)

## 8. OTHER ADJUSTMENT OPERATIONS BEFORE DELIVERING THE VEHICLE TO CUSTOMER

**Caution:**

If the delivery mode fuse is removed, the DTC related to the center information display (CID) is recorded. For the installation procedure of the delivery mode fuse, be sure to refer to "FUSE INSTALLATION" in "Pre-delivery Inspection".  Ref. to PRE-DELIVERY INSPECTION>PRE-DELIVERY INSPECTION (PDI) PROCEDURE > FUSE INSTALLATION.

Due to service and parts replacement convenience, perform the following operations before delivering the vehicle to the customer.

No.	Item	Check operation	Adjustment operation	Additional adjustment operations when replacing parts
1	Positions of devices <ul style="list-style-type: none"> <li>• Steering wheel</li> <li>• Mirror assembly inner rearview</li> <li>• Outer mirror</li> <li>• Seat</li> <li>• Air conditioner vent grille</li> </ul>	Is the device set to the same position when the vehicle was received from the customer?	Adjust the device to the similar position when the vehicle was received from the customer.	When removing/installing each device <ul style="list-style-type: none"> <li>• Combination meter, instrument panel, steering column, etc.</li> <li>• Mirror assembly inner rearview, roof trim, sunroof assembly, etc.</li> <li>• Outer mirror, door panel, etc.</li> <li>• Seat, floor carpet, etc.</li> <li>• Vent grille, instrument panel, console box, etc.</li> </ul>
2	Positions of switches <ul style="list-style-type: none"> <li>• Wiper, light (AUTO or OFF)</li> <li>• Illumination control</li> </ul>	Is the switch set to the same position when the vehicle	Set the switch to the same position when the vehicle was	When removing/installing each switch

No.	Item	Check operation	Adjustment operation	Additional adjustment operations when replacing parts
	<ul style="list-style-type: none"> <li>Room light</li> <li>Seat heater</li> </ul>	was received from the customer?	received from the customer.	

## 9. PARTS CLEANING

### Caution:

**Do not spray parts cleaner directly to rubber parts such as bushing or other resin parts.**

- Perform the operation in a clean location and use extra caution in dust proofing.
- Clean the items (except for assembly components) with steam, etc. before disassembly. During steam cleaning, wrap the air breather, oil level gauge, connectors, etc. with vinyl tape to prevent steam from entering inside the parts.
- Use an appropriate cleaning solvent.
- Do not clean rubber parts such as O-ring, gasket and oil seal with cleaning solution.

## 10. FASTENERS NOTICE

Fasteners must be tightened to the specified torque.

To prevent bolt and nut looseness, do not apply paint, lubricant, rust retardant or other substance to the installation surfaces of bolts, nuts, etc.

## 11. ABOUT SCREWS

Use an appropriate sized tool. Insert a screw vertically into the hole. Check for any loose screws after installation.

If improper tools are used or screws are inserted obliquely to the hole, the screws cannot be installed correctly, which may result in insufficient tightening force or damage on the hole.

## 12. STATIC ELECTRICITY DAMAGE

Do not touch the control modules, connectors, logic boards and other such parts when there is a risk of static electricity. Always use a static electricity prevention cord or touch grounded metal for the elimination of static electricity before conducting work.

## 13. TROUBLESHOOTING OF ELECTRICAL SYSTEM

1. Always refer to "CAUTION" of "General Description" in the same models service manual before starting the diagnostics and repair.
2. Always refer to the cautions of each section when diagnosing and repairing each system and component.
3. The battery cable must be disconnected from the battery sensor ground terminal after the ignition switch is set to the OFF position, unless otherwise required by the diagnostics.
4. When disconnecting a connector, do not pull the harness, but pull while holding the connector housing.

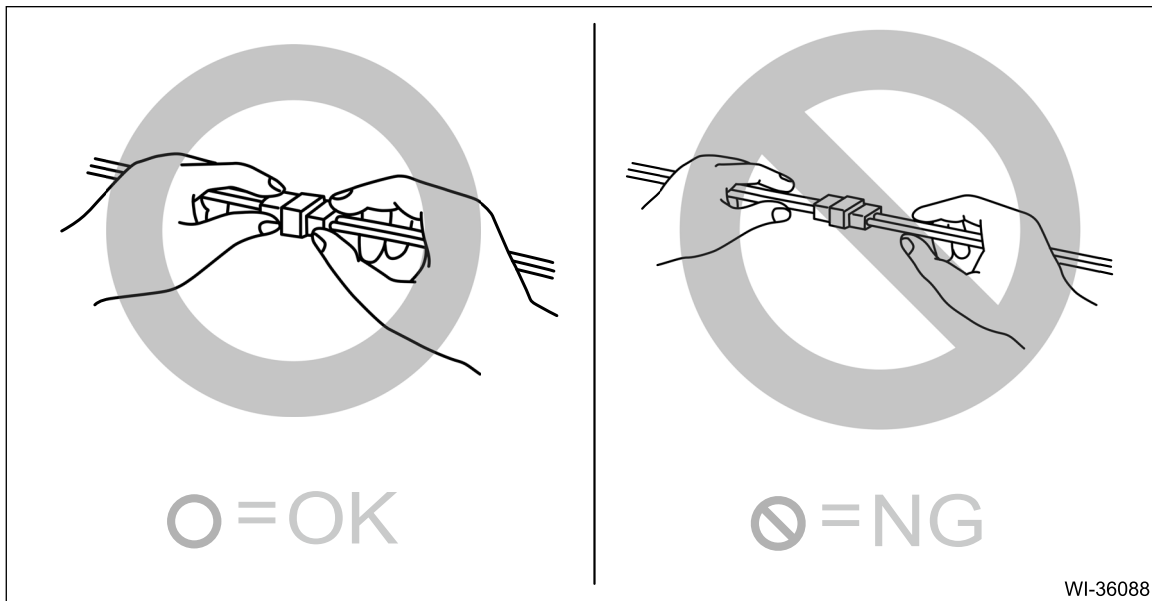

5. Confirm the locking shape completely before disconnecting a connector. In addition, firmly push in the connector until a click sounds when connecting a connector.
6. Be sure to prevent water or oil from contacting the connector terminals except for the integrated connector.
7. When checking continuity between connector terminals, or measuring voltage across the terminal and ground, always touch tester probe(s) to terminals from the harness side.  
When measuring the waterproof type connector terminal voltage, or the resistance between the terminals, use the check board.  
If the probe is too thick to gain access to the terminal, do not push it in forcibly but use a mini test lead.
8. When measuring the voltage or resistance of individual sensors or all electrical control modules, use a tapered pin with a diameter of 0.6 mm (0.024 in) or less and touch it to the tip of terminal. Never insert the tapered pin into the terminal at this time. Doing so may cause internal deformation and a malfunction can occur.

**Caution:**

**If a taper pin or the like has been inserted into the connector terminal, replace the connector.**

9. To check waterproof type connectors (which are not measurable from the harness side), touch tester probes on the terminal side and be very careful not to bend or damage the terminals.

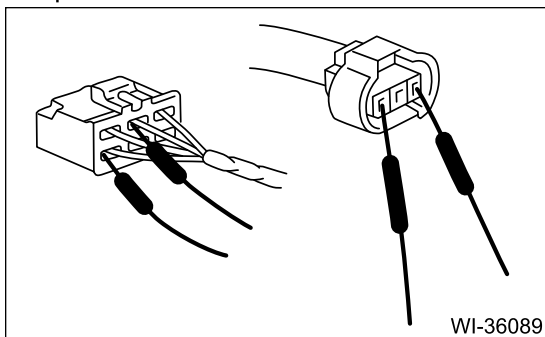

10. Securely fasten the harness with clamps and clips so that the harness does not interfere with the body end parts, edges, bolts or screws.
11. When installing a harness and a component, be careful not to catch them on the harness.

**12.** Sensors, relays, units, etc., are sensitive to strong impacts. Handle them with extra care so that they are not dropped or mishandled.

**13.** When inspecting the airbag system, in order to avoid malfunction, always refer to "CAUTION" of "General Description" of the airbag system in the same model's service manual.  [Ref. to AIRBAG SYSTEM>General Description>CAUTION.](#)

## **14. FUSE**

For the installation procedure of the delivery mode fuse, be sure to refer to "FUSE INSTALLATION" in "Pre-delivery Inspection".  [Ref. to PRE-DELIVERY INSPECTION>PRE-DELIVERY INSPECTION \(PDI\) PROCEDURE > FUSE INSTALLATION.](#)

## **15. IMMOBILIZER RELATED PART**

- Do not replace the immobilizer related parts with the parts from other vehicle.
- Registration of the immobilizer is necessary when an immobilizer-related control module has been replaced. For detailed operation procedure, refer to the "REGISTRATION MANUAL FOR IMMOBILIZER" provided as a separate volume.

## **16. LIFT AND JACK**

When using a lift or shop jack to raise a vehicle or using rigid rack to support a vehicle, always follow instructions concerning jack-up points and weight limits to prevent the vehicle from falling, which could result in injury. Be especially careful that the vehicle is balanced before raising it. Be sure to set the wheel stoppers when jacking-up only the front or rear side of the vehicle.

### **Caution:**

**Select the lift attachment so that the side sill does not contact the lift arm.**

**Note:**

- When using a lift, follow its operation manual.
- When the side spoiler or side garnish contacts the lift arm, use a lift attachment.
- Do not work or leave unattended while the vehicle is supported with jack, support it with rigid racks.
- Be sure to use the rigid racks with rubber attached to cradle to support the vehicle.
- When using a lift, use an attachment or something similar.
- When using a plate lift, use a rubber attachment. Place the attachment to the specified position of the vehicle, by adjusting front/rear and left/right sides accordingly so that it does not interfere with the under cover or other parts.

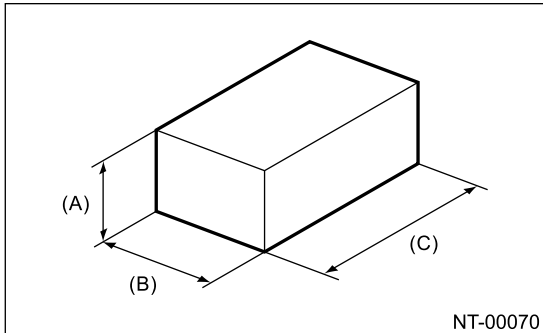

(A) 80 mm (3.1 in) or more

(B) 80 – 100 mm (3.2–3.9 in)

(C) 120 – 200 mm (4.7–7.9 in)

- Align the cushion rubber center part of plate lift with the center part of rubber attachment.
- Do not use the plate lift whose attachment does not reach the supporting locations.

• **SUPPORT LOCATIONS**

VB-\*BU

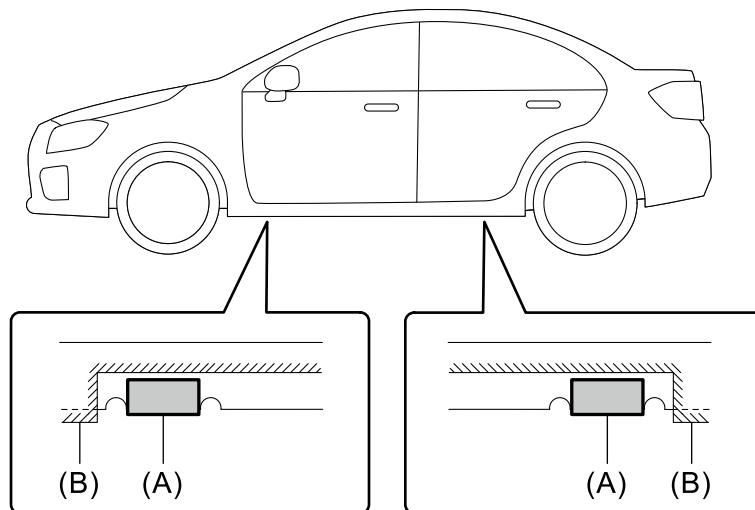

NT-10415

(A) Jack-up point

(B) Side spoiler or side garnish

• **PANTOGRAPH JACK**

VB-\*BU

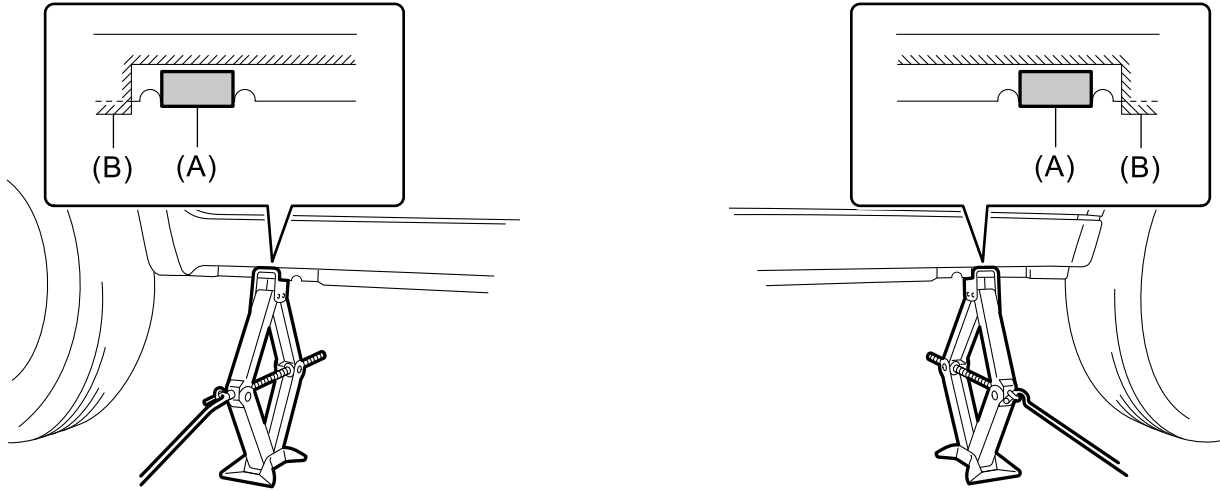

NT-10414

(A) Jack-up point

(B) Side spoiler or side garnish

• LIFT

VB-\*BU

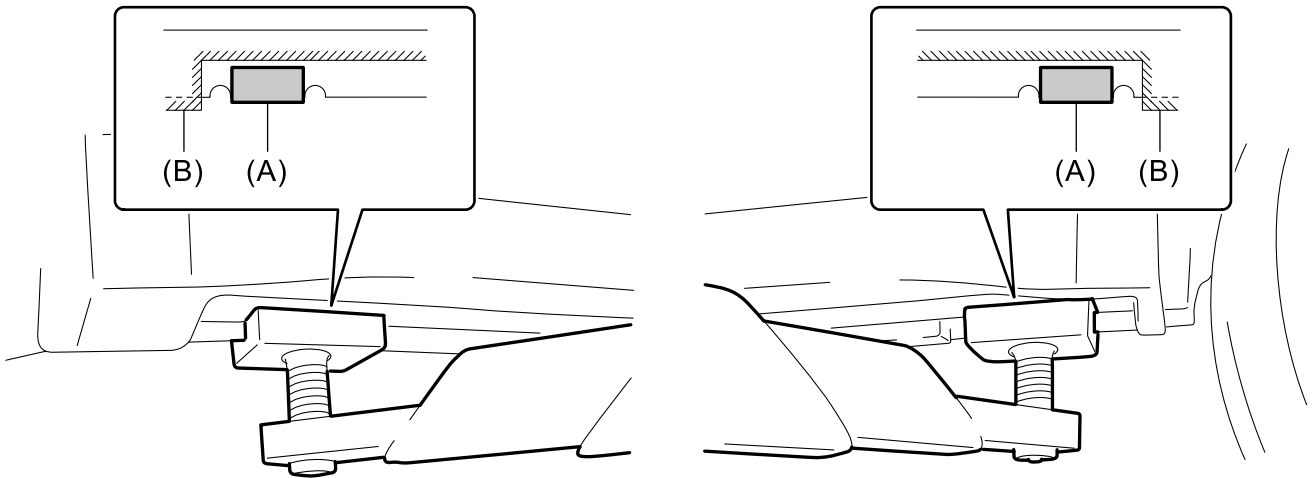

NT-10412

(A) Jack-up point

(B) Side spoiler or side garnish

**Caution:**

**For models with side spoiler or side garnish, use a spacer or an attachment to lift up the vehicle securely at jack up point without the side spoiler or side garnish contacting the lift.**

● RIGID RACK

VB-\*BU

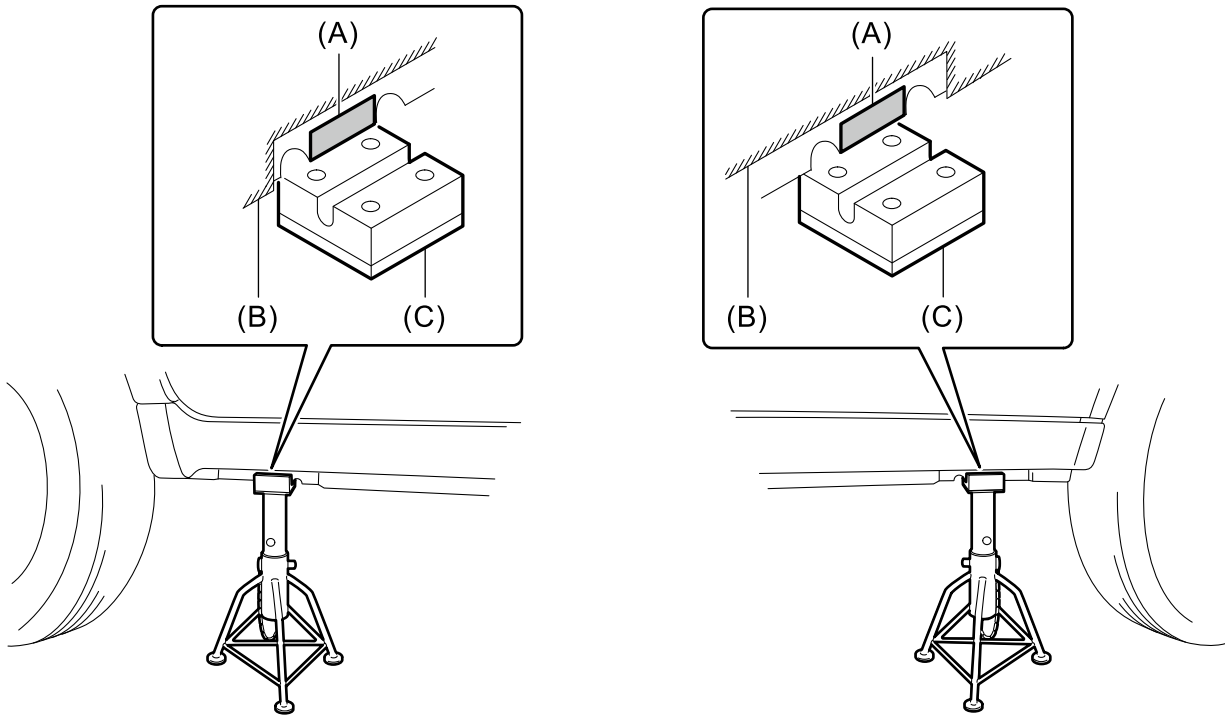

NT-10411

(A) Jack-up point

(B) Side spoiler or side garnish

(C) Attachment

● PLATE LIFT

VB-\*BU

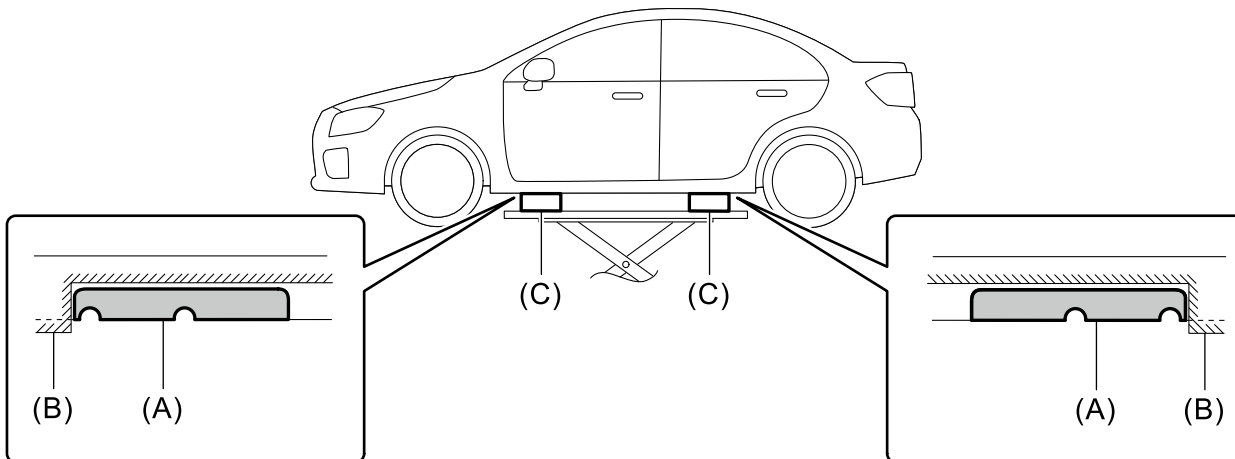

NT-10410

(A) Jack-up point

(B) Side spoiler or side garnish

(C) Attachment

● JACK-UP POINT (WHEN USING A GARAGE JACK)

VB-\*BU

(A)

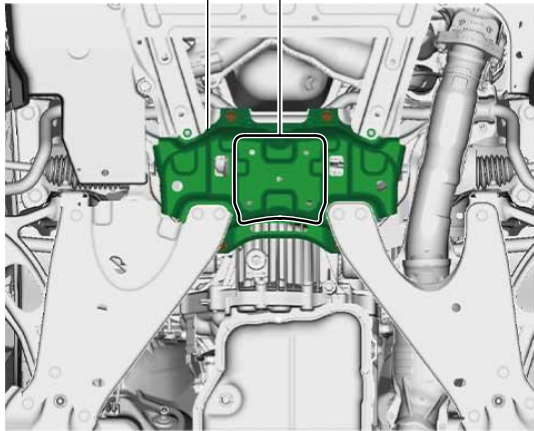

(B)

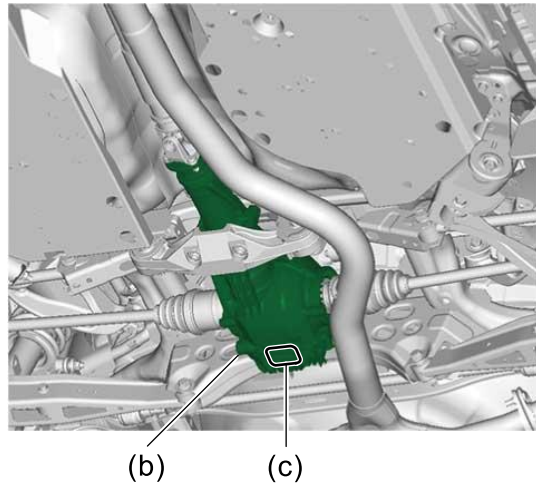

NT-10423

(A) Front

(B) Rear

(a) Crossmember support front

(b) Rear differential

(c) Jack-up point

**Caution:**

**If jacking up the front side of the vehicle, make sure that the jack is attached at the center of the crossmember support front, not at the sides.**

## 17. TIE-DOWNS

**Caution:**

**If any of the following conditions is met, the headlight beam may deviate. If the headlight beam deviates, perform fuse resetting.  Ref. to LIGHTING SYSTEM>Auto Headlight Beam Leveler System>PROCEDURE > FUSE RESET.**

- **Difference has occurred to the angle of road surface between when the ignition switch is turned to OFF and when the ignition switch is turned to ON.**
- **Difference has occurred to the angle of road surface between when the ignition switch is turned to OFF and when the vehicle speed is 0 km/h (0 MPH).**

Tie-downs are used when transporting vehicles. Remove the grommet of the rear tie-down hole and install the tie-down only to the specified locations on the vehicle.

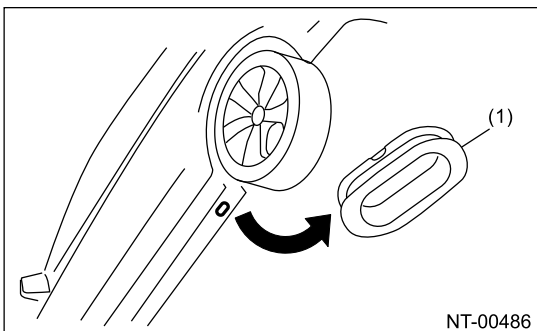

NT-00486

(1) Grommet

## ● TIE-DOWN LOCATION

### Caution:

Make sure that the rear tie-down hole is firmly plugged with the grommet after the rear tie-down hole is used. Otherwise, dust, smell, etc. may come into the passenger compartment indirectly from the rear quarter, via the side sill from the rear tie-down hole.

VBN\*BU

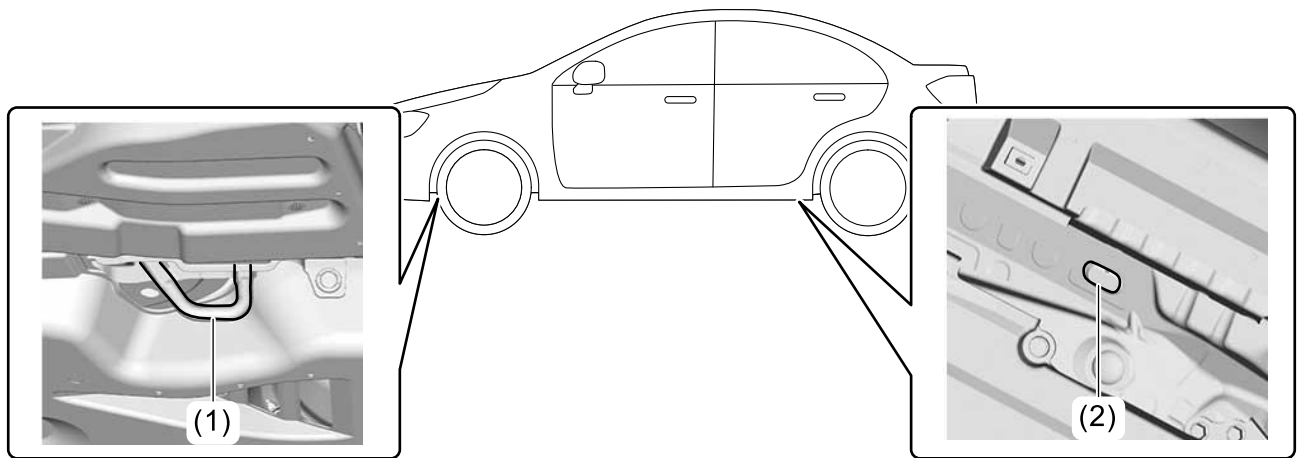

NT-10393

(1) Front tie-down hook

(2) Rear tie-down hole

## ● CHAIN DIRECTION AT TIE-DOWN CONDITION

### Caution:

- Pull the front and rear of the vehicle in the opposite direction, and pull the left and right of the vehicle in the same direction.
- Do not pull the chain except for the following recommended patterns.

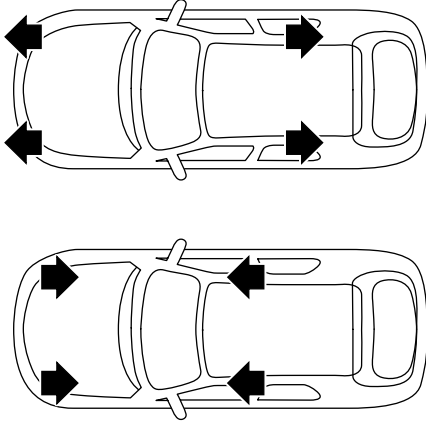
	Recommended
Tie-down direction	 <p>NT-00214</p>

● **TIE-DOWN RANGE**

For ground transportation

**Caution:**

**When the vehicle is tied down toward the vehicle inside, hook the hooks on the rear tie-down holes from vehicle inside. When the vehicle is tied down toward the vehicle outside, hook the hooks from vehicle outside.**

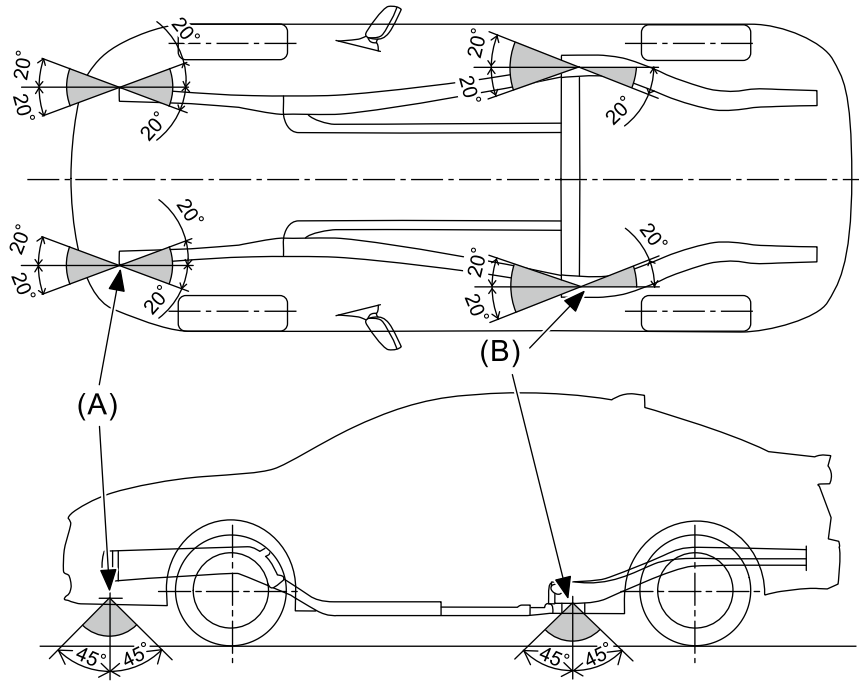

(A) Front tie-down hook

(B) Rear tie-down hole

(C) Chain pulling range at tie-down condition

For sea transportation

**Caution:**

**Hook on the front tie-down hook from vehicle outside, and tie down toward vehicle outside.**

**Also, hook on the front tie-down hook and the towing hook (eyebolt) from top to bottom.**

**The towing hooks (eyebolts) are exclusively used for towing and sea transportation tie-down, and do not use them for ground and freight transportation.**

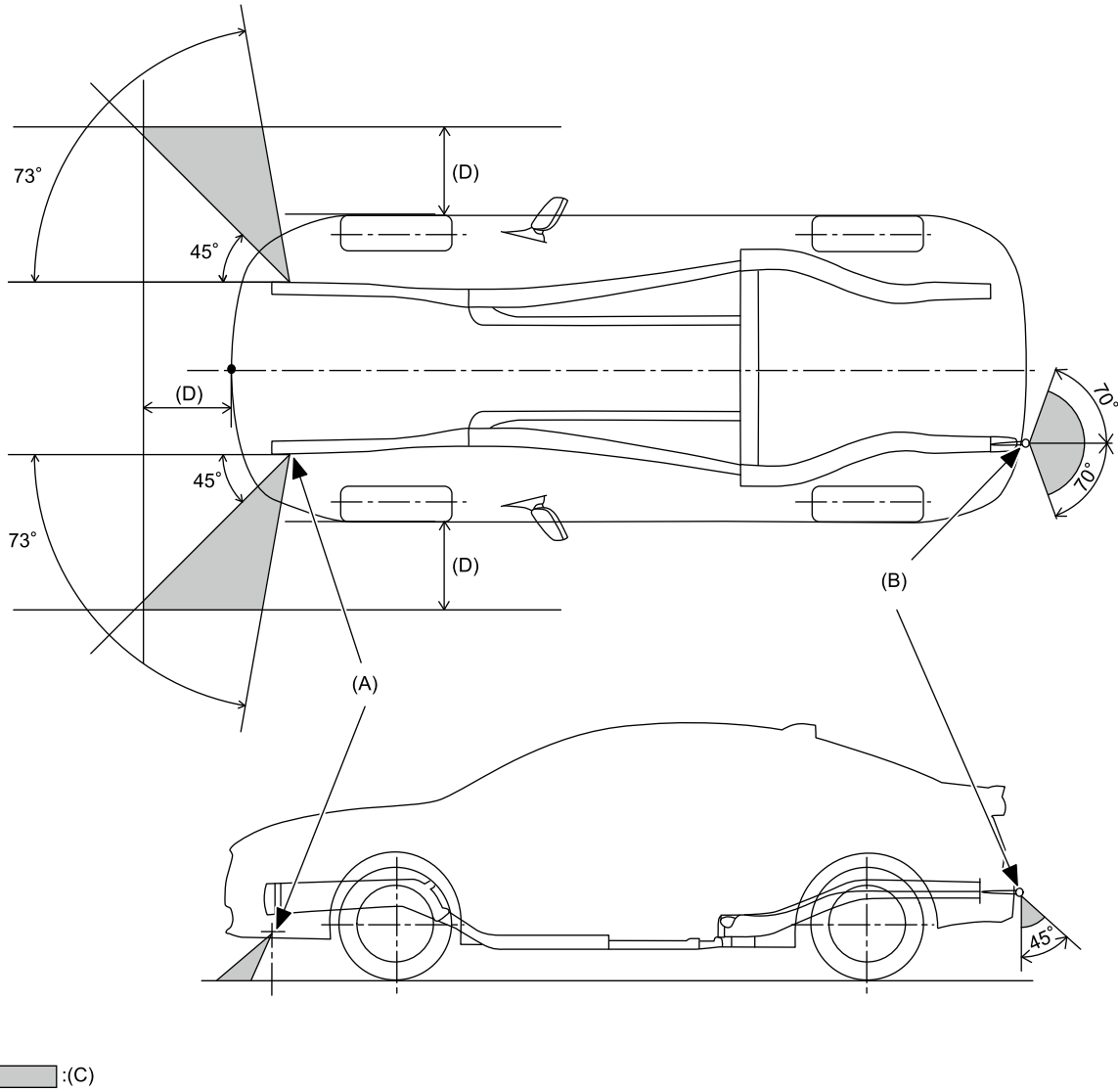

(A) Front tie-down hook

(C) Chain pulling range at tie-down condition

(D) 400 mm (15.7 in)

(B) Towing hook (eyebolt)

Tie-down at 2 locations

**Caution:**

**Pull the tie-down hook rope evenly to the front and rear side. Do not hook the hooks outside the wheelbase to avoid up/down pitching.**

**Note:**

**The length (D) should be the same.**

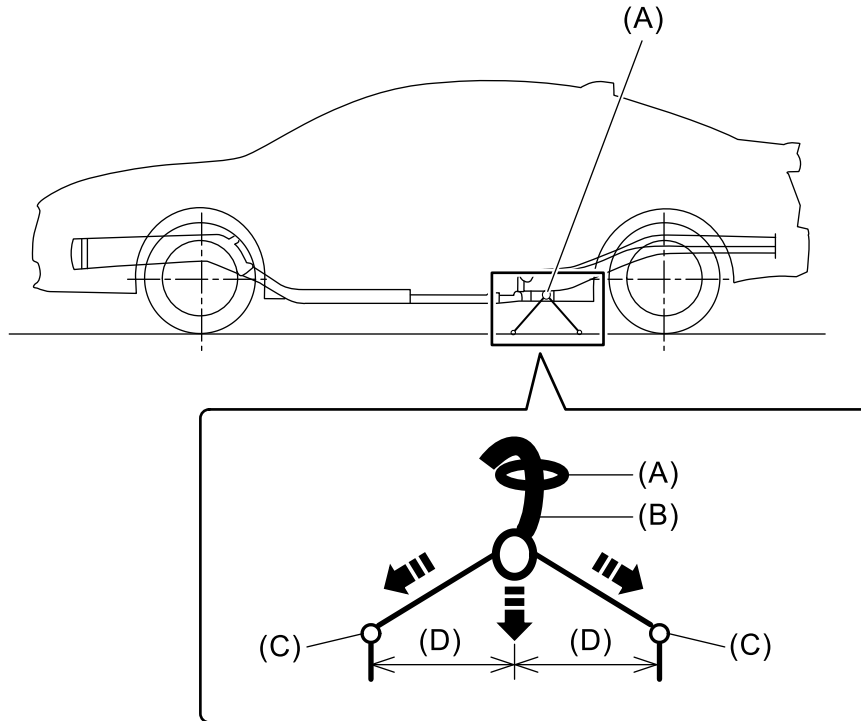

(A) Rear tie-down hole

(B) Tie-down hook

(C) Hook

(D) Rope length

#### • VEHICLE SINKING VOLUME AT TIE-DOWN CONDITION

##### **Caution:**

**The vehicle sinking volume at tie-down condition should be less than 50 mm (2 in) and make sure to fix the vehicle securely. Check to see if the tensions of chains or belts at tie-down condition are appropriate in the following procedures.**

- 1.** Before tie-down, measure the distance between the highest tire point and highest arch point at the center of wheel.
- 2.** After tie-down, measure the distance between the highest tire point and highest arch point at the center of wheel.
- 3.** If the distance (A) between the measured value of 1. and 2. above is less than 50 mm (2 in), it is judged as OK. If the distance is 50 mm (2 in) or more, it is judged as NG because the tension is too high.

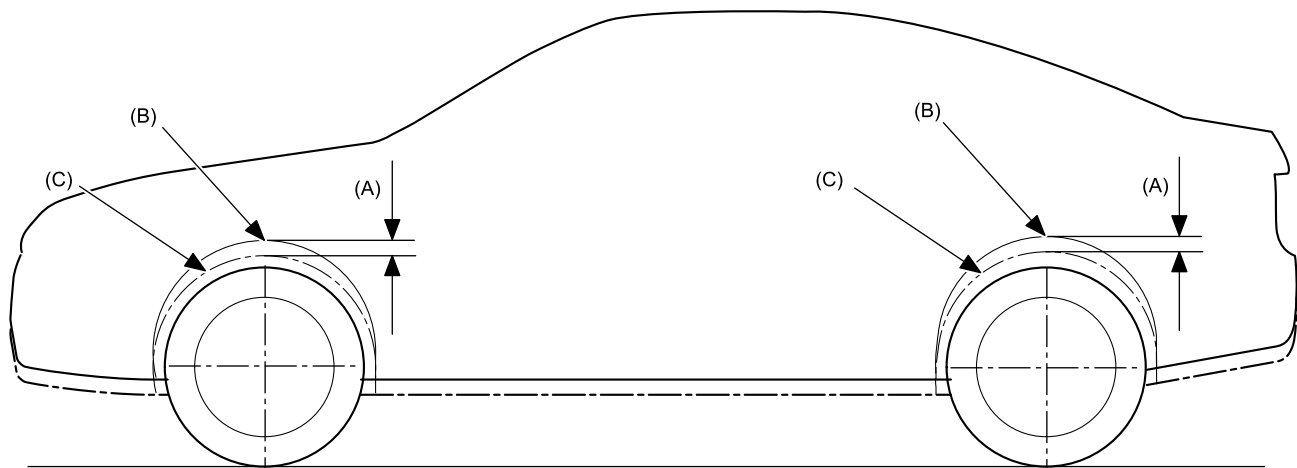

(A) Vehicle sinking volume at tie-down condition    (B) Arch position before tie-down    (C) Arch position after tie-down

### NOTES FOR THE USE OF FRONT TIE-DOWN HOOK

When the vehicle is tied down from vehicle inside, hook the hooks of tie-down chain from vehicle inside, and when the vehicle is tied down from vehicle outside, hook the hooks of tie-down chain from vehicle outside.

For front tie-down hook, use S hook and J hook, and for rear tie-down hole, use S hook, J hook and T hook. T hook can be used only for rear tie-down hole.

## 18. TOWING

Avoid towing vehicles except when the vehicle cannot be driven. Use a loader instead of towing. When towing other vehicles, pay attention to the following to prevent hook or vehicle damage resulting from excessive weight.

- Make sure the vehicle towing is heavier than the vehicle being towed.
- When towing the vehicle equipped with EyeSight, be sure to turn OFF the pre-collision brake function from EyeSight setting items on the center information display (CID). (Check that the pre-collision brake OFF indicator light in the meter lights up.)
- Front
  - Remove the hook cover, and install the towing hook (eyebolt).

**Caution:**

- **Make sure to detach the towing hook (eyebolt) after towing. If the hook remains attached, airbag may not operate properly when receiving a shock from front side. And it may also affect the crash performance of the vehicle.**
- **Do not tow using front tie-down hooks.**

VBN\*BU

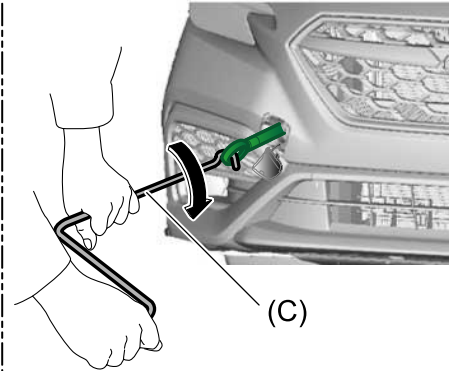
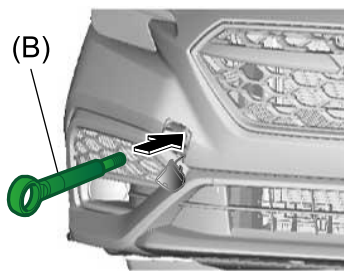
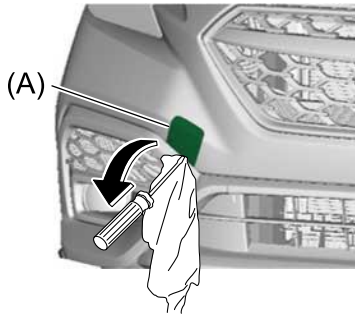

NT-10398

(A) Hook cover

(B) Towing hook (eyebolt)

(C) Jack handle

• **Rear**

Remove the hook cover, and install the towing hook (eyebolt).

**Caution:**

**Make sure to detach the towing hook (eyebolt) after towing. If the hook remains attached, the fuel leakage control function of the fuel pump may not operate properly when receiving a shock from rear side. And it may also affect the crash performance of the vehicle.**

VBN\*BU

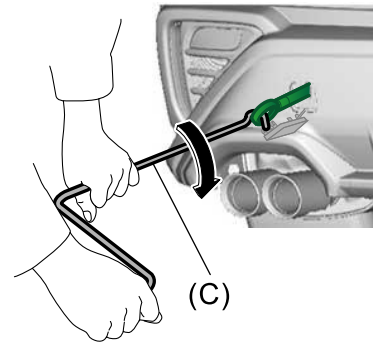
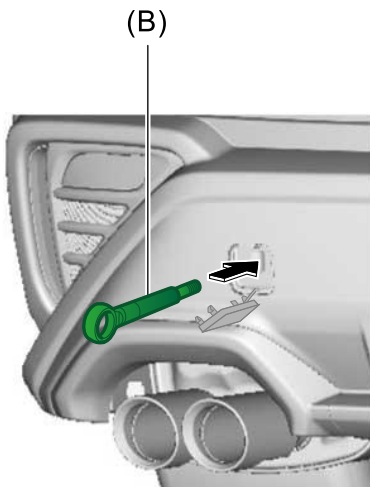
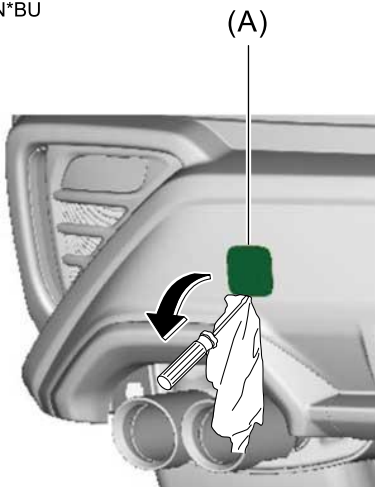



NT-10399

(A) Hook cover

(B) Towing hook (eyebolt)

(C) Jack handle

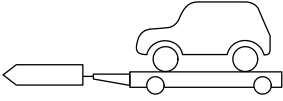
• Precautions

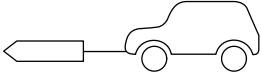
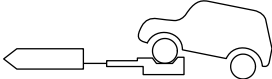
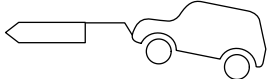
Towing method	Precautions	MT	CVT
Lifting up four wheels (on a trailer)    NT-00023	Towing the vehicle after lifting up all four wheels is a basic rule.  <b>Caution:</b> <b>When loading on a carrier transport, make sure to follow the procedures for "CARRIER CAR".</b>  <a href="#">Ref. to REPAIR CONTENTS&gt;NOTE &gt; CARRIER CAR.</a>	○	○
Rope    NT-00024	Check if both front and rear wheels are rotated normally. CVT model driving conditions: Driving speed of 20 MPH (32 km/h) or less, driving distance of 31 miles (50 km) or less	○	▲
Raising the front wheels    NT-00025	Towing the vehicle after lifting up all four wheels is a basic rule.	×	×
Lifting up the front wheels    NT-00026	Prohibited, due to potential damage on bumper face front, front grille assembly, etc. Do not raise the vehicle using the bumper face front.	×	×

Marked ○: OK, Marked ×: Prohibited, Marked ▲: Conditionally OK

**Caution:**

- Place the gear shift lever in neutral position or the select lever in "N range" during towing.
- Do not lift up the rear wheels to avoid unsteady rotation.
- Turn the ignition switch to "ACC", then check that the steering wheel moves freely. (Model without keyless access with push button start)
- Turn the ignition switch to "ACC" or "ON" position, and check that the steering wheel moves freely. (Model with keyless access with push button start)
- Release the parking brake to avoid tire dragging.
- Since the power steering does not work, be careful for the heavy steering effort. (When engine is stopped)
- Since the servo brake does not work, be careful that the brake is not applied effectively. (When engine is stopped)
- In case of the malfunction of internal transmission or drive system, lift up four wheels (on a trailer) for towing.
- Do not use towing hook (eyebolt) except when towing.
- While being towed with all four wheels on the ground, turn the ignition switch to ON but do not run the engine. (Do not start the engine.)
- If any of the following conditions is met, the headlight beam may deviate. If the headlight beam deviates, perform fuse resetting.  [Ref. to LIGHTING SYSTEM>Auto Headlight Beam Leveler System>PROCEDURE > FUSE RESET.](#)
  - Difference has occurred to the angle of road surface between when the ignition switch is turned to OFF and when the ignition switch is turned to ON.
  - Difference has occurred to the angle of road surface between when the ignition switch is turned to OFF and when the vehicle speed is 0 km/h (0 MPH).

## 19. CARRIER CAR

**Caution:**

If any of the following conditions is met, the headlight beam may deviate. If the headlight beam deviates, perform fuse resetting.  [Ref. to LIGHTING SYSTEM>Auto Headlight Beam Leveler System>PROCEDURE > FUSE RESET.](#)

- Difference has occurred to the angle of road surface between when the ignition switch is turned to OFF and when the ignition switch is turned to ON.
- Difference has occurred to the angle of road surface between when the ignition switch is turned to OFF and when the vehicle speed is 0 km/h (0 MPH).

When carrying the vehicle onto a car carrier truck, observe the following precautions.

**Caution:**

- When carrying the vehicle onto a car carrier truck, perform the operation being careful with the gap between the height of the carrier's floor and the vehicle lower side because of little clearance under the front bumper.

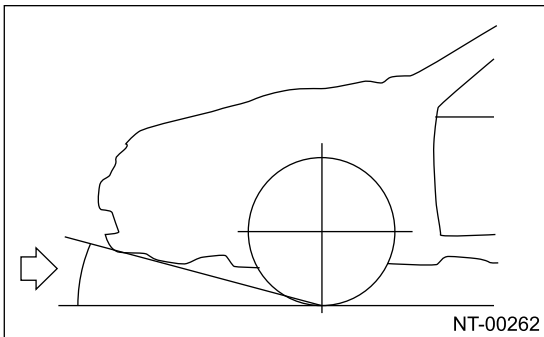

- Use a supporting board (rubber) where the clearance is too small.
- Perform the operation being careful with the position shown in the figure below.

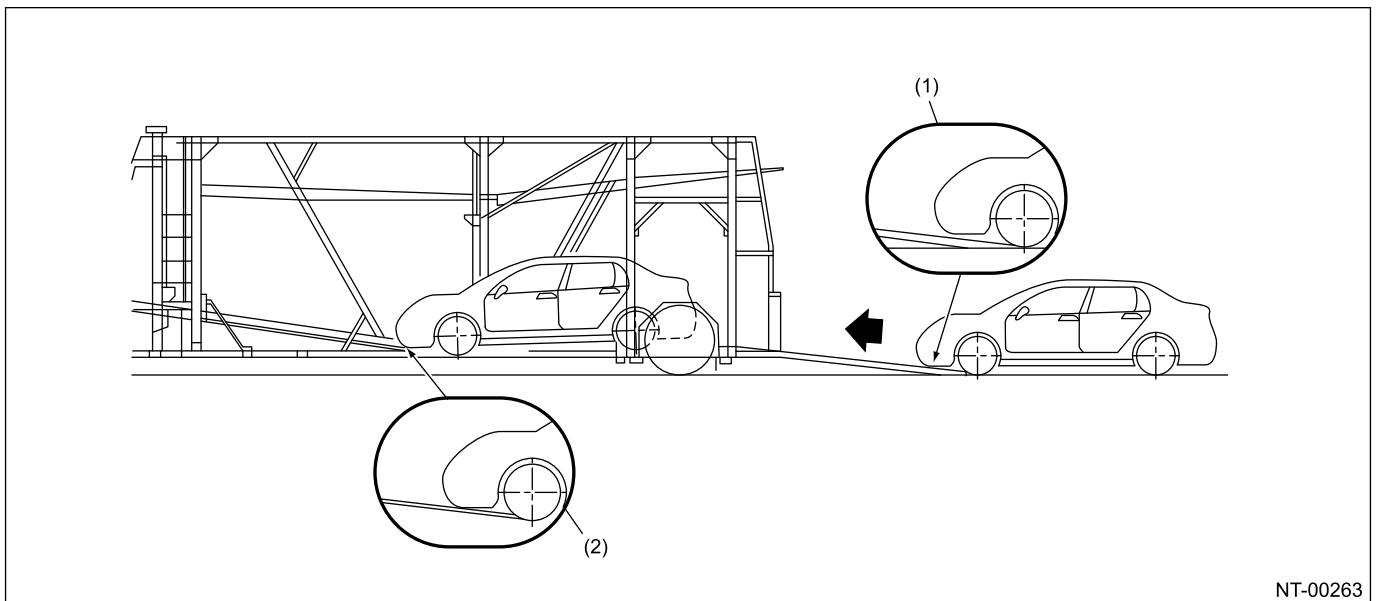

- (1) Use a supporting board (rubber) to ensure clearance from the ramp. (2) Before carrying the vehicle completely, lower the lower center floor until it is level to make clearance.

Before lowering the vehicle from the carrier car, perform the following operations.

**Caution:**

**Always perform the following operations before lowering the vehicle from the carrier car. Otherwise, the power unit will rotate reversely, which may cause the damage to the engine, vacuum pump, and transmission.**

1. Start the engine.
2. Set the transmission gear shift lever or select lever position into driving direction of the vehicle. (When the vehicle drives forward, do not shift the transmission in reverse or "R range". When the vehicle drives rearward, do not set the transmission to 1 — 6 speed, or to "D range".)

**Caution:**

**Be sure to perform 2. mentioned above even if the engine cannot be started in some reasons.**

## 20. FRONT HOOD GAS STAY

1. Always attach the gas stay to the normal position when performing works such as inspections and general maintenance.

**Caution:**

- **During the inspection and general maintenance, always be sure to turn the ignition switch to OFF.**
- **At the inspection and general maintenance, do not detach the gas stay.**

VBN\*BU

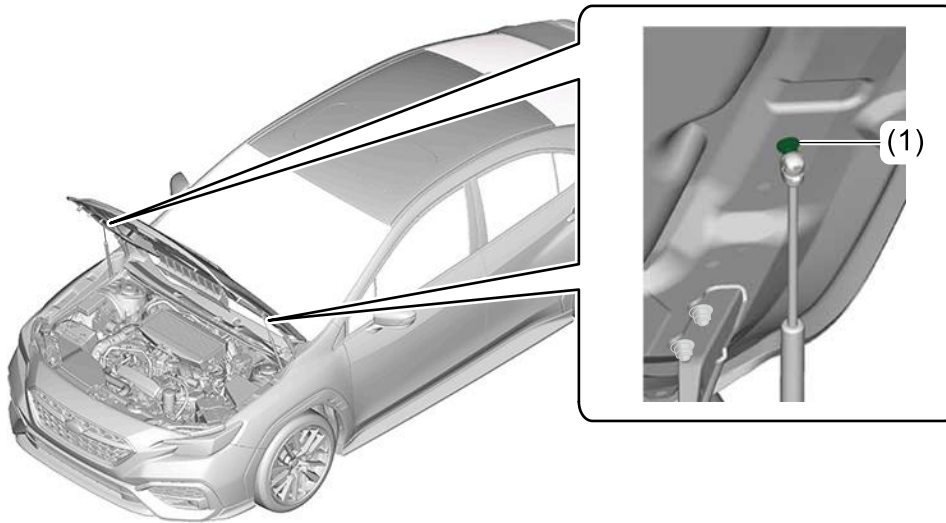

NT-10400

(1) Normal attached position

2. When wider hood opening is necessary, set the gas stay to the lower position on the front hood side as shown in the figure.

**Caution:**

- **The hood cannot be closed with the gas stay on the full open side. When it is necessary to close, tie the hood striker and the radiator panel with a string etc. to fix them.**
- **After work, set the gas stays back to the normal position and tighten the bolts to the specified torque.**

Tightening torque: 20 N·m (2.0 kgf-m, 14.8 ft-lb)

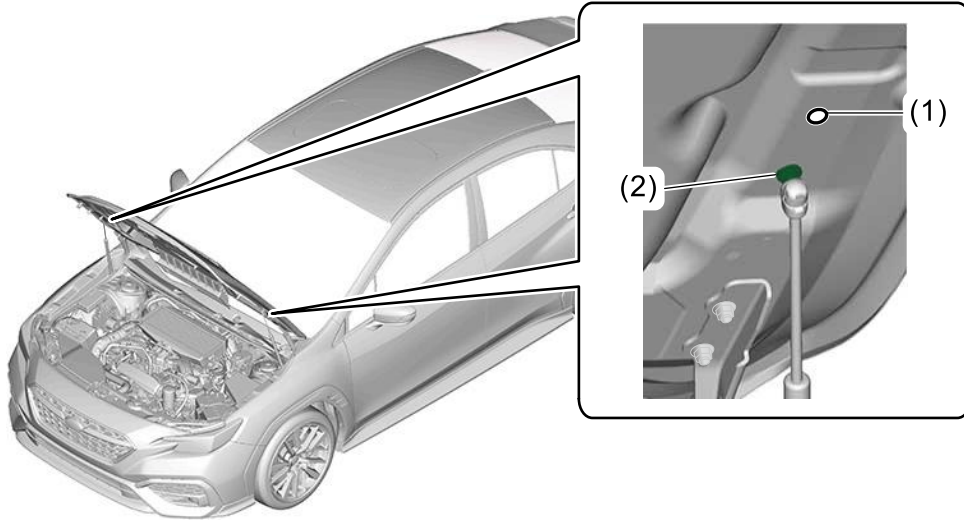

(1) Normal attached position

(2) Installation position at full open

## 21. SCAN TOOL

Using scan tools will greatly improve the efficiency of repairing electrically controlled parts. Subaru Select Monitor can be used to diagnose the engine, VDC, air conditioner and other electrically controlled parts.

## 22. AWD CIRCUIT MEASURES

- MT model  
Since viscous coupling (limited slip differential) is used in the center differential, cut-off of AWD circuit cannot be carried out.
- CVT model  
Since VTD type is used in the center differential, cut-off of AWD circuit cannot be carried out.

## 23. SPEEDOMETER TEST

### 1. Rear wheel free roller system

- (1) Set the free roller on the floor of rear wheel side securely according to the wheel base and rear tread of the vehicle.
- (2) Let the vehicle ride on the tester and free roller gently.

#### **Caution:**

**Fix the vehicle using a pulling metal (chain or wire).**

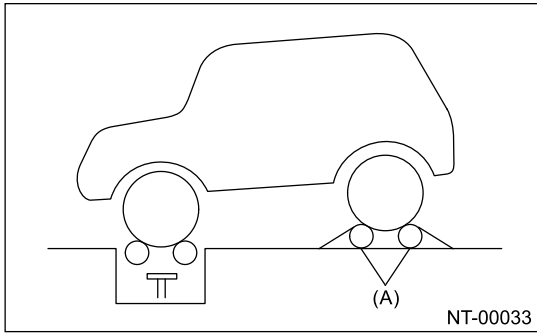

(A) Free roller

- (3) Set the speedometer tester.
- (4) Conduct the speedometer test work.

**Caution:**

- Do not operate the steering wheel.
- Avoid abrupt operations of the acceleration pedal and brake pedal.
- Perform the measurement while driving the vehicle at 50 km/h (31 MPH) or less and complete within one minute.
- Be sure to turn OFF the pre-collision brake function.

**2.** Rear wheel jack-up system

- (1) Set the vehicle on speedometer tester.

**Caution:**

**Fix the vehicle using a pulling metal (chain or wire).**

- (2) Jack up the rear wheels and set the rigid racks to the rear side jack up point.

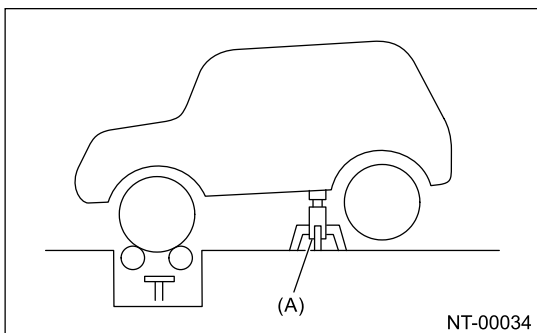

(A) Rigid rack

- (3) Conduct the speedometer test work.

**Caution:**

- Do not operate the steering wheel.
- Avoid abrupt operations of the acceleration pedal and brake pedal.
- Perform the measurement while driving the vehicle at 50 km/h (31 MPH) or less and complete within one minute.
- Be sure to turn OFF the pre-collision brake function.

**24. BRAKE TEST**

- 1.** Keep the front or rear wheels on the ground during measurement.

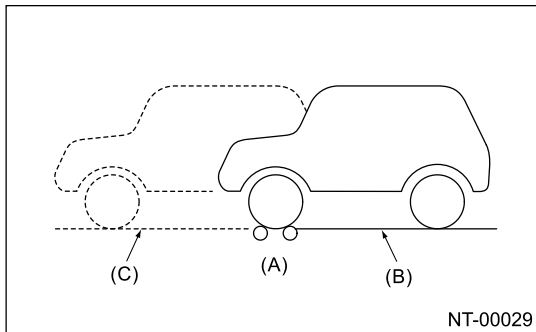

- (A) Brake tester
- (B) Position for measuring front wheel
- (C) Position for measuring rear wheel

2. When the brake dragging force is large
  - Check the dragging of brake pad.

**Judgment standards:**

	<b>Braking force</b>
Rear wheel total	10% or more of load on front or rear wheels
Difference between right and left wheels	8% or less of load on front or rear wheels
Grand total	50% or more of vehicle weight at the time of test

- When measurement is difficult to carry out because both of front wheels are locked, brake force measurement in this condition conforms to standard grand total.

## 25. ON THE CAR WHEEL BALANCING

**Caution:**

- **Be sure to carry out the procedures after measuring the balance of each single tire.**
- **Set the vehicle so that the front and rear wheels are the same height.**
- **Make sure that the VDC is deactivated.**
- **Release the parking brake during measurement.**
- **Rotate each wheel by hands, and make sure it rotates without dragging.**
- **Do not operate the clutch quickly and do not accelerate or decelerate suddenly during work.**
- **When an error is indicated during engine drive, do not use the motor drive together.**

1. Jack up the non-measuring side (front wheels or rear wheels) and set the rigid racks.
2. Set the pickup stands to two wheels of the measuring side (front wheels or rear wheels).

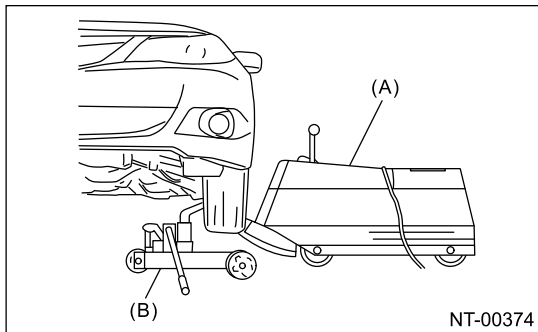

(A) Balancer body

(B) Pickup stand (right and left)

3. For drive wheel, drive the tires with engine for measurement.
4. For non-drive wheel, drive the tires from the on the car wheel balancer for measurement.

## 26. Bluetooth CONNECTION PROCEDURE BETWEEN HEAD UNIT (AUDIO WITHOUT NAVIGATION) AND SMARTPHONE

Perform the following operations to allow the head unit to obtain the time information.

- When Android mobile phone is used
  1. Establish Bluetooth connection between the head unit and Android mobile phone.

**Note:**

**Bluetooth connection will be established when the blue text "Connected" is displayed in the screen of the head unit.**

2. Delete the connecting device after 10 seconds passed.
- When iPhone is used
    1. Establish Bluetooth connection between the head unit and iPhone.
    2. Operate iPhone to go to the connecting device "Subaru BT" and turn the item "Show Notifications" ON.
    3. Cancel Bluetooth connection, and establish Bluetooth connection again.
    4. Delete the connecting device after 10 seconds passed.

# IDENTIFICATION

*ID*

---

## 1. Identification

## IDENTIFICATION

### 1. IDENTIFICATION NUMBER & LABEL LOCATIONS

The V.I.N. (Vehicle Identification Numbers) is used to classify the vehicle.

- **Positioning of the plate label for identification**

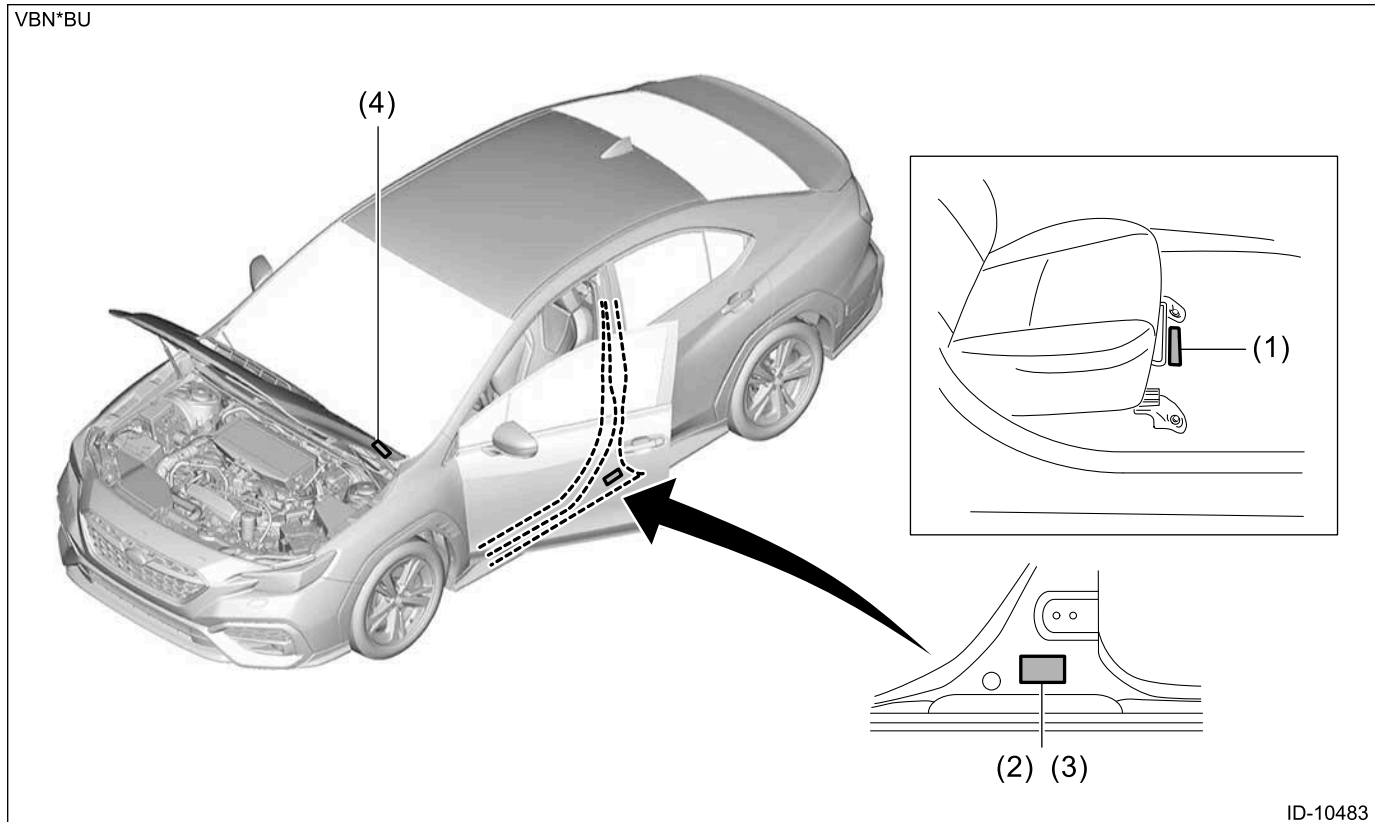

(1) VIN (Vehicle Identification Number) (below right front floor carpet)

(2) FMVSS or CMVSS label (attached to left side of vehicle)

(3) Model number label (attached to right side of vehicle)

(4) V.I.N. label

- **Engine**

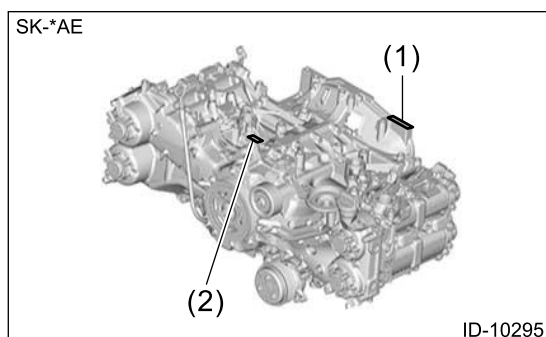

(1) Engine serial No.

(2) Engine type (crankcase upper side)

- **Manual transmission**

6MT

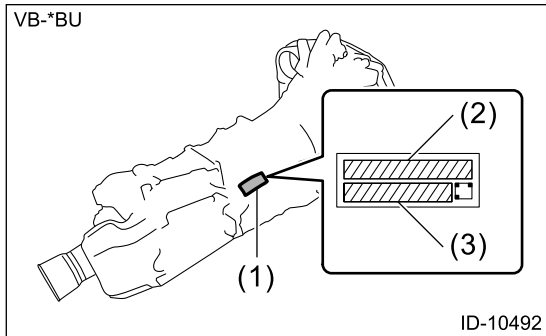

- (1) Label
- (2) MT type
- (3) Transmission serial No.

- **Automatic transmission**

CVT

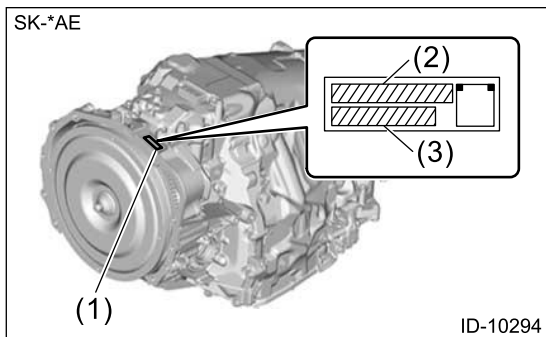

- (1) Label
- (2) CVT type
- (3) Transmission serial No.

- **Rear differential**

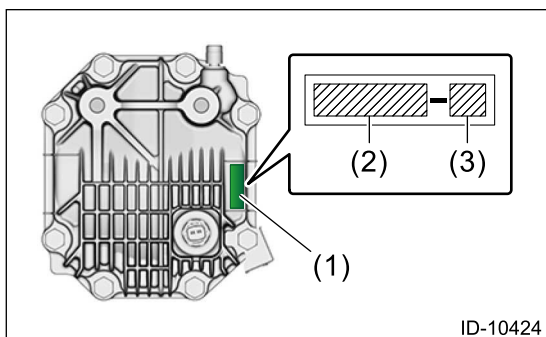

- (1) Label
- (2) Rear differential serial No.
- (3) Rear differential identification

- **FMVSS label**

For U.S.A.

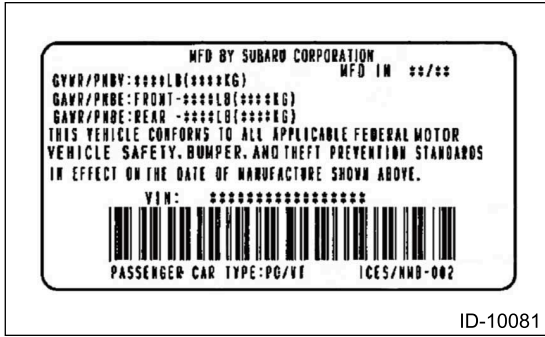

• **CMVSS label**

For Canada

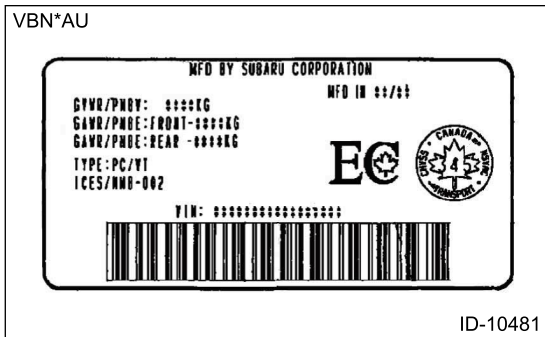

• **Model number label**



**2. MEANING OF V.I.N**

The meaning of the V.I.N. is as follows:

**[JF1VBAA6XN880001]**

The starting and ending brackets ( [ ] ) are stop marks.

Digits	Code	Meaning	Details
1 — 3	JF1	Manufacturer body area	JF1: Passenger car, SUBARU CORPORATION made
4	V	Car line	V: WRX
5	B	Body type	B: Sedan
6	A	Displacement class	A: 2.4 L GASOLINE 4CYLINDERS 271HP 4WD DI TURBO
7	A	Grade	A: WRX Base B: WRX Base+EyeSight

Digits	Code	Meaning	Details
			F: WRX Premium H: WRX Premium+EyeSight K: WRX Limited L: WRX Limited+Navi M: WRX Limited+EyeSight N: WRX Limited+EyeSight+Navi T: WRX GT+EyeSight+RECARO U: WRX GT+EyeSight+Navi+RECARO
8	6	Restraint or GVWR class	6: Manual belts + dual airbag + side airbag for seat back + curtain airbag for roof + knee airbag (driver's seat)
9	X	Check digit	0 – 9 & X
10	N	Model year	N: 2022MY
11	8	Transmission type and manufacturing plant	8: Full-time AWD CVT (main plant, Gunma) 9: Full-time AWD 6MT (main plant, Gunma)
12 – 17	800001 –	Serial number	800001 – 999999

### 3. MODEL NUMBER LABEL

The model number label indicates: the applied model, the option code, the trim code, the engine type, the transmission type, and the exterior color code. This information is helpful when placing orders for parts.

#### VBHBYE6

Digits	Code	Meaning	Details
1	V	Series	V: WRX
2	B	Body type	B: SEDAN
3	H	Total engine displacement / drive system	H: 2.4 L DI turbo AWD
4	B	Model year	B: 2022MY
5	Y	Destination	Y: U.S., Canada and Mexico
6	E	Grade	D: WRX Premium B E: WRX base F: WRX Premium A H: WRX Limited J: WRX base EyeSight K: WRX Premium EyeSight L: WRX Limited EyeSight M: WRX GT EyeSight
7	6	Fuel feed system / transmission	6: DI DOHC turbo/AWD L-6MT (TY75) 8: DI DOHC turbo/AWD-CVT (TR69)

The engine and transmission type are as follows.

**ENGINE**

**FA24FXZHBA**

Digits	Code	Meaning	Details
1 and 2	FA	Engine type symbol	FA: 4 cylinder gasoline
3 and 4	24	Displacement	24: 2.4 L
5	F	Valve train/fuel supply system/steering	F: DOHC DI turbo (LH)
6	X	Exhaust regulations	X: U.S. (Tier 3/LEV 3)
7	Z	Intake/exhaust system	Z: Intake AVCS, exhaust AVCS, TGV, EGR
8	H	Mounted transmission	B: 6MT H: CVT
9 and 10	BA	Detailed specifications	Used when ordering parts. For details, refer to the parts catalog.

**TRANSMISSION (6MT)**

**TY751V6###**

Digits	Code	Meaning	Details
1	T	Transmission symbol	T: Transmission
2	Y	Transmission system	Y: Full-time AWD
3 and 4	75	Distance between gear center	75: 75 mm (2.95 in) between main shaft and drive pinion
5	1	Classification	1: 6MT
6	V	Transmission basic specifications	V: Model without Auto Start Stop, single range 6MT
7	6	Mounted engine	6: 2.4 L turbo
8 – 10	###	Detailed specifications	Used when ordering parts. For details, refer to the parts catalog.

**TRANSMISSION (CVT)**

**TR690S6BCA**

Digits	Code	Meaning	Details
1	T	Transmission symbol	T: Transmission
2	R	Transmission system	R: Full-time AWD CVT

3 and 4	69	Distance between pulley centers	69: 169 mm (6.65 in) between pulley centers
5	0	Classification	0: CVT
6	S	Transmission specifications	G: Without Auto Start Stop, with CVTF cooler (with warmer feature), without CVTF cooler (air cooler) S: Without Auto Start Stop, with CVTF cooler (with warmer feature), with CVTF cooler (air cooler)
7	6	Mounted engine	6: 2.4 L turbo
8 to 10	BCA	Detailed specifications	Used when ordering parts. For details, refer to the parts catalog.

### REAR DIFFERENTIAL

<b>Identification</b>	<b>Reduction gear ratio</b>	<b>LSD</b>
E2	4.111	None
E4	4.444	None

**OPTION CODE**

U4

- 1-digit number

	<b>B</b>	<b>E</b>	<b>H</b>	<b>O</b>	<b>P</b>	<b>Q</b>	<b>R</b>
Genuine leather seat	-	-	○	-	○	○	-
RECARO seat	-	-	-	○	-	-	○
Cold weather package	○	○	-	○	○	○	-
Privacy glass	-	-	-	-	-	-	-
Advanced package	-	○	○	○	-	○	○
Safety view package	-	-	-	-	-	-	-

- 2-digit number

	<b>C</b>	<b>D</b>	<b>E</b>	<b>F</b>	<b>G</b>	<b>H</b>	<b>Q</b>	<b>R</b>
Base audio	-	○	-	-	-	-	○	○
High audio	-	-	○	○	-	○	-	-
Navigation system	○	-	-	-	○	-	-	-
Telematics	-	-	-	-	○	○	-	○
Sunroof	○	-	-	○	○	○	-	-
Rear spoiler	○	-	-	○	○	○	○	○
Smart rearview mirror	-	-	-	-	-	-	-	-

	<b>S</b>	<b>W</b>
Base audio	-	-
High audio	○	○
Navigation system	-	-
Telematics	○	-
Sunroof	-	-
Rear spoiler	○	○
Smart rearview mirror	-	-

**4. IMMOBILIZER REGISTRATION TYPE**

- Model without keyless access with push button start  
For United States, refer to "Type G" described in "REGISTRATION MANUAL FOR IMMOBILIZER".  
For Canada, refer to "Type I" described in "REGISTRATION MANUAL FOR IMMOBILIZER".
- Model with keyless access with push button start  
Refer to "Type H" described in "REGISTRATION MANUAL FOR IMMOBILIZER".

# RECOMMENDED MATERIALS

***RM***

---

## 1. Recommended Materials

## RECOMMENDED MATERIALS

---

**Caution:**

**To insure the best performance and safety, always use the recommended fuel, oil, refrigerant, grease, primer, adhesive and sealant, or an alternative or substitute of equivalent quality.**

### **1. FUEL**

Use proper gasoline which meets the conditions below in order to avoid malfunction.



- Use unleaded gasoline.
- Do not use the low quality gasoline, or improper fuel such as diesel fuel, fuel alcohol, or gasoline additive.
- Always use gasoline that is equivalent to that prescribed in the owner's manual or that of high octane value.

## 2. GREASE

### • ENGINE OIL

**Caution:**

- Use 0W-20 (synthetic oil).
- It is acceptable to fill with an engine oil of another brand, but make sure to use the engine oil corresponding to the following standards.

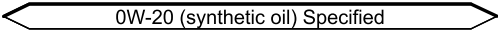
Item	Recommended and alternative materials																
API standard	 <p style="text-align: right;">RM-10105</p> <p>Those with SP "RESOURCE CONSERVING" logo.</p>																
ILSAC standard	 <p style="text-align: right;">RM-00002</p> <p>Those with GF-6A certification mark (starburst mark).</p>																
SAE viscosity No. and applicable temperature	<p style="text-align: center;">0W-20 (synthetic oil) specified</p> <table border="1" style="margin-left: auto; margin-right: auto;"> <tr> <td>(°C)</td> <td>-30</td> <td>-20</td> <td>-15</td> <td>0</td> <td>15</td> <td>30</td> <td>40</td> </tr> <tr> <td>(°F)</td> <td>-22</td> <td>-4</td> <td>5</td> <td>32</td> <td>59</td> <td>86</td> <td>104</td> </tr> </table> <p style="text-align: center;">  </p> <p style="text-align: right;">RM-10002</p>	(°C)	-30	-20	-15	0	15	30	40	(°F)	-22	-4	5	32	59	86	104
(°C)	-30	-20	-15	0	15	30	40										
(°F)	-22	-4	5	32	59	86	104										

### • ENGINE COOLANT

**Note:**

The SUBARU Super Coolant contains anti-freeze and anti-rust agents, and is especially made for Subaru engines with an aluminum cylinder block.

Be sure to use SUBARU Super Coolant, since other coolant may cause corrosion.

Item	Recommended and alternative materials
Engine coolant	<ul style="list-style-type: none"> <li>• <b>Recommended materials:</b> SUBARU made SUBARU SUPER COOLANT*1*2</li> </ul>
Cooling system protective agent	<ul style="list-style-type: none"> <li>• <b>Recommended materials:</b> SUBARU made Cooling system conditioner (part No. SOA345001)</li> </ul>

\*1 : Distilled water is recommended for dilution. Soft water or tap water can be used alternatively.

\*2 : There are two types of SUBARU SUPER COOLANT: concentrated type and diluted type (part No. K0670Y0001).

#### ● TRANSMISSION GEAR OIL

<p><b>Caution:</b> Do not mix different kinds of oil.</p>
<p><b>Note:</b> When using the substitute product, the function and performance may be inferior.</p>
<b>Recommended and alternative materials</b>
<ul style="list-style-type: none"> <li>• <b>Recommended materials:</b> SUBARU made GEAR OIL EXTRA MT</li> <li>• <b>Alternative:</b> API standard GL-5 (75W-90)</li> </ul>

#### ● CVTF

<p><b>Caution:</b> Always use specified CVTF. Using fluid other than specified CVTF will cause malfunction.</p>
<b>Specified materials</b>
<ul style="list-style-type: none"> <li>• <b>Specified materials:</b> SUBARU made SUBARU High Torque CVT Fluid LV</li> </ul>

#### ● DIFFERENTIAL GEAR OIL

<p><b>Caution:</b> Do not mix different kinds of oil.</p>	
<p><b>Note:</b> Using any materials other than recommended may result in abnormal noise, vibration, functional decline, or poor fuel economy.</p>	
Item	Recommended and alternative materials
Front differential	<ul style="list-style-type: none"> <li>• <b>Recommended materials:</b> SUBARU made GEAR OIL EXTRA MT</li> <li>• <b>Alternative:</b> API standard GL-5 (75W-90)</li> </ul>

Item	Recommended and alternative materials
Rear differential (VB-type)	<ul style="list-style-type: none"> <li>• <b>Recommended materials:</b> API standard GL-5 (75W-90)</li> <li>• <b>Alternative:</b> API standard GL-5 (90)</li> </ul>

#### • BRAKE FLUID

<p><b>Caution:</b></p> <ul style="list-style-type: none"> <li>• <b>Do not let brake fluid come into contact with the painted surface of the vehicle. Wash away with water immediately and wipe off if it is spilled by accident.</b></li> <li>• <b>Do not mix different kinds of brake fluid.</b></li> <li>• <b>Do not allow water or foreign matter to enter the reservoir tank.</b></li> <li>• <b>Always use new brake fluid when replacing or refilling the brake fluid.</b></li> </ul>
<b>Recommended and alternative materials</b>
<ul style="list-style-type: none"> <li>• <b>Recommended materials:</b> FMVSS No. 116 DOT3 or DOT4</li> </ul>

#### • CLUTCH FLUID

<p><b>Caution:</b></p> <ul style="list-style-type: none"> <li>• <b>Do not let clutch fluid come into contact with the painted surface of the vehicle. Wash away with water immediately and wipe off if it is spilled by accident.</b></li> <li>• <b>Do not mix different kinds of clutch fluid.</b></li> <li>• <b>Do not allow water or foreign matter to enter the reservoir tank.</b></li> <li>• <b>Always use new clutch fluid when replacing or refilling the clutch fluid.</b></li> </ul>
<b>Recommended and alternative materials</b>
<ul style="list-style-type: none"> <li>• <b>Recommended materials:</b> FMVSS No. 116 DOT3 or DOT4</li> </ul>

### 3. REFRIGERANT AND COMPRESSOR OIL

<p><b>Caution:</b></p> <ul style="list-style-type: none"> <li>• <b>Use the refrigerant and compressor oil listed in the following table.</b></li> <li>• <b>Do not mix different kinds of refrigerant and compressor oil.</b></li> </ul>	
<b>Item</b>	<b>Recommended and alternative materials</b>
Refrigerant	<ul style="list-style-type: none"> <li>• <b>Recommended materials:</b> HFO-1234yf</li> </ul>
Compressor oil	<ul style="list-style-type: none"> <li>• <b>Recommended materials:</b> VC100YF</li> </ul>

### 4. GREASE

#### • EXHAUST

Application point	Recommended and alternative materials
Oxygen sensor (front oxygen (A/F) sensor, rear oxygen sensor)	<ul style="list-style-type: none"> <li>• <b>Recommended materials:</b> CRC5-56 (part No. 004301003) or equivalent</li> </ul>

Application point	Recommended and alternative materials
	<ul style="list-style-type: none"> <li>• <b>Recommended materials:</b> NEVER-SEEZ NSN and JET LUBE SS-30 or equivalent</li> </ul>

• **MT**

Application point	Recommended and alternative materials
MT main shaft (spline parts)	<ul style="list-style-type: none"> <li>• <b>Recommended materials:</b> NICHIMOLY N-130 or equivalent</li> </ul>
Main shaft oil seal (lip)	
Taper roller bearing (transfer case side)	
Taper roller bearing (extension case side)	
Release lever	
Release bearing (inner circumference)	
Master cylinder (push rod)	<ul style="list-style-type: none"> <li>• <b>Recommended materials:</b> Silicone grease G-40M or equivalent</li> </ul>
MT gear shift lever	<ul style="list-style-type: none"> <li>• <b>Recommended materials:</b> NIPPON GREASE NIGHTIGHT LTS No. 2 or equivalent</li> </ul>
Shift lever COMPL	
Clutch pedal	
Master cylinder (clevis pin)	

• **CVT**

Application point	Recommended and alternative materials
Shifter arm	<ul style="list-style-type: none"> <li>• <b>Recommended materials:</b> NIPPON GREASE NIGHTIGHT LTS No. 2 or equivalent</li> </ul>

• **BRAKE**

Application point	Recommended and alternative materials
Brake pedal (spacer)	<ul style="list-style-type: none"> <li>• <b>Recommended materials:</b> NIPPON GREASE NIGHTIGHT LTS No. 2 or equivalent</li> </ul>
Clevis pin (connecting the operating rod and brake pedal)	
Slide pin	<ul style="list-style-type: none"> <li>• <b>Recommended materials:</b> NIPPON GREASE NIGLUBE RX-2 (part No. 000041000) or equivalent</li> </ul>
Slide pin lock	
Support front disc brake	
Support rear disc brake (except for electronic parking brake model)	<ul style="list-style-type: none"> <li>• <b>Recommended materials:</b> DOW CORNING TORAY Molykote M7439 or equivalent</li> </ul>
Support front disc brake	
Support rear disc brake (except for electronic parking brake model)	
Pad clip	<ul style="list-style-type: none"> <li>• <b>Recommended materials:</b> Henkel TEROSON VR 500 or equivalent</li> </ul>
Support rear disc brake (electronic parking brake model)	

● **PARKING BRAKE**

Application point	Recommended and alternative materials
Rear brake back plate	<ul style="list-style-type: none"> <li>• <b>Recommended materials:</b> DOW CORNING TORAY Molykote 44MA or equivalent</li> </ul>
Parking lever pin	
Adjuster assembly	
Strut	
Inner cable end	<ul style="list-style-type: none"> <li>• <b>Recommended materials:</b> NIPPON GREASE Spray Grease G2272 or equivalent</li> </ul>
Parking brake lever (tooth face portion)	<ul style="list-style-type: none"> <li>• <b>Recommended materials:</b> NIPPON GREASE NIGHTIGHT LTS No. 2 or equivalent</li> </ul>

● **DOOR**

Application point	Recommended and alternative materials
Sliding section of hinge assembly door	<ul style="list-style-type: none"> <li>• <b>Recommended materials:</b> NIPPECO LT-1N</li> <li>• <b>Alternative:</b> Lithium soap grease (not containing silicone) Base oil: Mineral oil based Consistency: NLGI No. 1</li> </ul>
Remote assembly door	<ul style="list-style-type: none"> <li>• <b>Recommended materials:</b> Shin-Etsu Chemical SILICONE GREASE G-30M (part No. 004404002) or equivalent</li> </ul>
Frame assembly front door outer	

● **STEERING**

Application point	Recommended and alternative materials
Steering gearbox (rack and pinion)	<ul style="list-style-type: none"> <li>• <b>Recommended materials:</b> KYODO YUSHI Multemp ACEP or equivalent</li> </ul>
Steering angle sensor	<ul style="list-style-type: none"> <li>• <b>Recommended materials:</b> Contained item or KYODO YUSHI Multemp L or equivalent</li> </ul>
Steering gearbox (boot and tie-rod installation parts)	<ul style="list-style-type: none"> <li>• <b>Recommended materials:</b> Shin-Etsu Chemical Silicone grease G-40M or equivalent</li> </ul>

● **DRIVE SHAFT**

Application point	Recommended and alternative materials
Front drive shaft	<ul style="list-style-type: none"> <li>• <b>Recommended materials:</b></li> </ul>

Application point	Recommended and alternative materials
	– IN side: NKG302 or the equivalent
Rear drive shaft	• <b>Recommended materials:</b> NKG814 or the equivalent

• **AIR CONDITIONER**

Application point	Recommended and alternative materials
Mode door actuator lever (inside the rail of mode)	• <b>Recommended materials:</b> SUBARU genuine grease (part No. 72129AJ000)

• **TRUNK LID**

Application point	Recommended and alternative materials
Joint portion of torsion bar and sliding area of hinge	• <b>Recommended materials:</b> NIPPECO LTS-1N18L or the equivalent

• **AIRBAG SYSTEM**

Application point	Recommended and alternative materials
Steering roll connector	• <b>Recommended materials:</b> Contained item or KYODO YUSHI Multemp L or equivalent

• **STARTER**

Application point	Recommended and alternative materials
Internal gear sliding portion	• <b>Recommended materials:</b> Multemp #6129 or equivalent
Shaft spline portion	
Shift lever sliding portion	
Inside of the internal gear and pinion gear	• <b>Recommended materials:</b> Grease: Molykote® AG650 or equivalent

• **SEAT**

Application point	Recommended and alternative materials
Seat frame assembly cushion front seat (belt assembly front INN installation area)	• <b>Recommended materials:</b> APOLLOIL AUTOLEX A • <b>Alternative:</b> Lithium soap grease (not containing silicone) Base oil: Not specified Consistency: NLGI No. 2

## 5. ADHESIVE AND PRIMER

- Primer

Application point	Recommended and alternative materials
Fixed glass	<ul style="list-style-type: none"> <li><b>Recommended materials:</b> Dow Automotive's ESSEX U-401, U-402 or equivalent</li> </ul>
Body (glass adhesive surface)	<ul style="list-style-type: none"> <li><b>Recommended materials:</b> Dow Automotive's ESSEX U-413 or equivalent</li> </ul>
Rear bumper (sonar holder installation area)	<ul style="list-style-type: none"> <li><b>Recommended materials:</b> 3M Company K-540NT or the equivalent</li> </ul>

- Adhesive

Application point	Recommended and alternative materials
Fixed glass	<ul style="list-style-type: none"> <li><b>Recommended materials:</b> Dow Automotive's ESSEX U-400HV or equivalent</li> </ul>
Body	

## 6. SEAL MATERIAL

- ENGINE

Application point	Recommended and alternative materials
Oil pressure switch	<ul style="list-style-type: none"> <li><b>Recommended materials:</b> THREE BOND 1324 (part No. 004403042) or equivalent</li> </ul> <ul style="list-style-type: none"> <li><b>Recommended materials:</b> THREE BOND 1217G (part No. K0877Y0100), 1217H or equivalent</li> </ul>
PCV valve	
Oil pan	
Vacuum pump	
High-pressure fuel pump case	
Oil separator cover	
Front camshaft cap	
Rear camshaft cap	
Cylinder block	
Rocker cover	
Chain cover	
Oil pan upper	
Cylinder head	
Cylinder head gasket	
Camshaft carrier	
Main gallery plug	<ul style="list-style-type: none"> <li><b>Recommended materials:</b></li> </ul>
Cylinder block plug	

Application point	Recommended and alternative materials
-------------------	---------------------------------------

THREE BOND 1105 (part No. 004403010) or equivalent

• **MT**

Application point	Recommended and alternative materials
Extension case	<ul style="list-style-type: none"> <li>• <b>Recommended materials:</b> THREE BOND 1215B or equivalent</li> <li>• <b>Alternative:</b> THREE BOND 1215 (part No. 004403007)</li> </ul>
Transmission cover	
Transmission case	

• **CVT**

Application point	Recommended and alternative materials
Converter case cover	<ul style="list-style-type: none"> <li>• <b>Recommended materials:</b> THREE BOND 1215B or equivalent</li> <li>• <b>Alternative:</b> THREE BOND 1215 (part No. 004403007)</li> </ul>
Converter case	
Transmission case	
Oil pump chain cover	
Intermediate case	
Oil pan	<ul style="list-style-type: none"> <li>• <b>Recommended materials:</b> THREE BOND 1217B (part No. K0877YA020) or equivalent</li> </ul>

• **REAR DIFFERENTIAL**

Application point	Recommended and alternative materials
Drive pinion threads and self-locking nut (seat surface)	<ul style="list-style-type: none"> <li>• <b>Recommended materials:</b> THREE BOND 1324 (part No. 004403042) or equivalent</li> </ul>

• **STEERING**

Application point	Recommended and alternative materials
Steering adjusting screw	<ul style="list-style-type: none"> <li>• <b>Recommended materials:</b> THREE BOND 1111B or equivalent</li> </ul>

• **DOOR**

Application point	Recommended and alternative materials
Sealing cover	<ul style="list-style-type: none"> <li>• <b>Recommended materials:</b> 3M Butyl tape 8626 or equivalent</li> </ul>
Front door	<ul style="list-style-type: none"> <li>• <b>Recommended materials:</b> BAYER SILICONE SEALANT or equivalent</li> </ul>
Rear door	

# PRE-DELIVERY INSPECTION

*PI*

---

1. Pre-delivery Inspection

## PRE-DELIVERY INSPECTION

### GENERAL DESCRIPTION

---

The purposes of the pre-delivery inspection (PDI) are as follows.

- Remove the vehicle protective parts for transportation.
- Check that the vehicle or parts before delivery are not damaged during transportation or storage.
- Check that the vehicle after repair is normal.
- Make sure to provide a complete vehicle to customer.

For above reasons, all SOA service centers must carry out the PDIs before delivery of vehicle.

Besides, all SOA service center and PDI center check the condition of all vehicles to make sure to take responsibility.

## PRE-DELIVERY INSPECTION

### PRE-DELIVERY INSPECTION (PDI) PROCEDURE

---

Perform the procedures indicated in the table below.

#### Static checks just after vehicle receipt

Item	Check point
1. Appearance	<ol style="list-style-type: none"><li>1. If the vehicle is covered with protective film, visually check the vehicle body for damage and dents. If the protective film has been removed, visually check the painted body surfaces in detail for damage or rust.</li><li>2. Visually check the glass and light lenses for any damage, cracks or excessive gaps between body sheet metal.</li><li>3. Visually check the plated parts for any damage.</li><li>4. Check the instrument panel, console and trim for stains or dirt.</li><li>5. Visually check the keyless transmitter or access key for damage.</li></ol>
2. Tire	<ol style="list-style-type: none"><li>1. Check the tires for damage, defective, and dents on wheels.</li><li>2. Check the tire air pressure.</li></ol>
3. Fuse installation	If the vehicle is about to be delivered to a customer, attach a delivery mode fuse to the delivery mode fuse inlet.
4. Lock/unlock and open/close operation of doors	<ol style="list-style-type: none"><li>1. Using the key, check the door can be locked or unlocked normally.</li><li>2. Open and close all doors to check that there are no problems.</li><li>3. Operate the power door lock switch to check that all doors lock and unlock normally.</li></ol>
5. Child safety lock system	Check the child safety lock system operates normally.
6. Trunk open/close operations	<ol style="list-style-type: none"><li>1. Operate the trunk opener button to check that the trunk opens normally.</li></ol>

Item	Check point
	2. Open and close the trunk to check that there are no problems.
7. Operation check of trunk lid release lever	Operate the trunk lid release lever to check that the trunk lock is unlocked normally.
8. Fuel lid lock/unlock and open/close operation	<ol style="list-style-type: none"> <li>1. Check the fuel lid can be locked or unlocked normally.</li> <li>2. With unlock condition, check the fuel lid can be opened normally.</li> <li>3. Check the fuel lid can be unlocked normally by using an emergency release cable.</li> </ol>
9. Towing hook (eyebolt)	At factory shipment, the towing hook (eyebolt) is installed to the bumper face rear. Remove the towing hook (eyebolt), and store it in the holder. Install the supplied rear hook cover to the vehicle.
10. Accessory	<p>Check that the following accessories are equipped.</p> <ul style="list-style-type: none"> <li>• Owner's manual</li> <li>• Warranty booklet</li> <li>• Maintenance note</li> <li>• Spare key</li> <li>• Key No. plate</li> <li>• Jack</li> <li>• Jack handle</li> <li>• Wheel nut wrench</li> <li>• Spare tire or puncture repair kit</li> <li>• Towing hook (eyebolt)</li> <li>• Screwdriver</li> </ul>
11. Front hood lock release	Operate the front hood lock release lever to check that the front hood opens normally.
12. Battery	Check the battery for any abnormal conditions such as rust or traces of battery fluid leaks.
13. Brake fluid	Check the brake fluid amount.
14. Engine oil	Check the engine oil amount.
15. Transmission gear oil	<ul style="list-style-type: none"> <li>• Check for leakage of the transmission gear oil.</li> <li>• Check that the transmission gear oil level is normal.</li> </ul>
16. CVTF	Check for leakage of CVTF.
17. Front differential gear oil (CVT model)	Check for leakage of front differential gear oil.
18. Rear differential gear oil	Check for leakage of rear differential gear oil.
19. Engine coolant	Check the engine coolant level.
20. Clutch fluid	Check the clutch fluid amount.
21. Window washer fluid	Check the window washer fluid amount.
22. Front hood latch	Check that the front hood is closed normally and locked securely.

<b>Item</b>	<b>Check point</b>
23. Keyless entry system	Check that the keyless entry system operates normally.
24. Keyless access system	Check that the keyless access system operates normally.
25. Alarm system	Check that the alarm system including front hood security system operates normally.
26. Seat	<ol style="list-style-type: none"> <li>1. Check the seat surfaces for stains or dirt.</li> <li>2. Check the seat installation conditions and functionality.</li> <li>3. Check that the seat heater system operates normally.</li> </ol>
27. Seat belt	<ol style="list-style-type: none"> <li>1. Check the seat belt installation conditions and functionality.</li> <li>2. Check the seat belt warning system operates normally.</li> </ol>
28. TPMS (U.S. model)	If the display of TPMS warning light does not operate normally, perform the diagnosis by referring to TIRE PRESSURE MONITOR (DIAGNOSTICS).
29. Horn	Check that the horn sounds.
30. Hazard light system	Check that the hazard lights illuminate.
31. Spot map light	After installing the delivery fuse, check if the spot map light illuminates or goes off normally.
32. Grommet	Install the grommet provided on the rear seat to the tie-down hole.

### **Checks with the engine running**

<b>Item</b>	<b>Check point</b>
33. Delivery mode	Turn the ignition switch to ON and check that the malfunction indicator light starts blinking.
34. Immobilizer system	<ol style="list-style-type: none"> <li>1. Check that the engine starts with all keys that are equipped on vehicle.</li> <li>2. Check that the security indicator light operates normally.</li> </ol>
35. Push button start function	Using the access key that is equipped on vehicle, operate the push button start function to check engine start and stop operations.
36. Starting condition	Start the engine and check that the engine starts smoothly.
37. Exhaust system	Check that there are no abnormal exhaust noises and exhaust gas leaks.
38. Indicator and warning lights	Check that all indicator lights and warning lights are operating correctly.
39. Heater & ventilation	Check that the heater & ventilation system operates normally.
40. Center information display (CID)	Check that the center information display (CID) function operates normally.
41. Telematics system	<ol style="list-style-type: none"> <li>1. Check that the indicator light on the overhead console goes off.</li> </ol>

<b>Item</b>	<b>Check point</b>
	2. Perform the Bluetooth connection procedure between head unit (without navigation) and smartphone.
42. USB power supply	Check that the USB power supply operates normally.
43. Accessory power supply socket	Check that the accessory power supply socket operates normally.
44. Lighting system	Check that the lighting system operates normally.
45. VDC	Check that the VDC OFF switch function operates normally.
46. Illumination control	Check that the illumination control operates normally.
47. Window washer system	Check that the window washer system operates normally.
48. Wiper system	Check that the wiper system operates normally.
49. Wiper deicer	Check that the wiper deicer operates normally.
50. Power window	Check that the power window operates normally.
51. Sunroof	Check that the sunroof operates normally.
52. Rear window defogger system	Check that the rear window defogger system operates normally.
53. Door mirror	1. Check that the remote control mirror operates normally. 2. Check that the heated door mirror operates normally.
54. Room mirror	Check that the automatic anti-glare function operates normally.
55. Blind Spot Detection / Rear Cross Traffic Alert (BSD/RCTA)	1. Check that the Blind Spot Detection/Rear Cross Traffic Alert (BSD/RCTA) system is activated and deactivated correctly. 2. Check the bumper face rear around the sensor for dirt, scratch, affixed stickers and poor paint coating.
56. Reverse Automatic Braking (RAB)	1. Check that the RAB system is activated and deactivated correctly. 2. Check the sonar sensor installed on the bumper face rear for parts missing, dirt, scratch, foreign objects, etc.
57. Parking brake	Check that the parking brake operates normally.
58. Diagnostic trouble code (DTC) check	Check that the diagnostic trouble code (DTC) is not detected.
59. EyeSight assist monitor	Check that the EyeSight assist monitor operates normally.
60. Auto vehicle hold (AVH) system	Check that the AVH system is activated and deactivated correctly.
61. Multi information display (MID) system	Check that the multi information display (MID) system operates normally.

### **Dynamic test with the vehicle running**

<b>Item</b>	<b>Check point</b>
62. Brake test	Check the foot brake for normal operations.
63. Shift control	Check that the shift patterns are correct.

Item	Check point
64. Cruise control	Check that the cruise control system operates normally.
65. EyeSight	Check that EyeSight operates normally.

### Checks after dynamic test

Item	Check point
66. Power steering system	Check the steering warning light operation.
67. Fluid leakage	Check for fluid/oil leaks.
68. Water leak test	Spray the vehicle with water and check for water leaks.
69. Appearance 2	<ol style="list-style-type: none"> <li>1. Peel the protective tape, protective film, vinyl wrapping and identification seal. (If equipped)</li> <li>2. Check the body paints for damage and stain.</li> <li>3. Check the plated parts for damage and rust.</li> </ol>

## 1. APPEARANCE

- If the vehicle is covered with protective film, visually check the vehicle body for damage and dents.
- When there is no protective film, check the painted body surfaces for damage or stains in detail and repair as necessary.
- Visually check the windshield glass, door glasses and light lenses for any damage, cracks or excessive gaps to the body panel and replace as necessary.
- Visually check the plated parts, such as the grilles and door knobs, for damage or loss of gloss and replace the parts as necessary.
- Check the instrument panel, console and trim for stains or dirt.
- Check the keyless transmitter or access key for dirt or damage, and wipe off or replace if necessary.

## 2. TIRES

- Check the tires for damage, defective, and dents on wheels.
- Check the tire size, spare tire and tire air pressure described on the tire air pressure label (driver's side).

## 3. FUSE INSTALLATION

At shipping

### Note:

- **Delivery mode fuse (30 A) is installed to the position (2) to prevent the battery consumption.**
- **Installing the delivery mode fuse to the position (2) activates the control during shipping (delivery mode).**

After shipping (immediately after the vehicle is delivered)

- 1.** Remove the delivery mode fuse from the position (2).
- 2.** Install the delivery mode fuse to the position (1).

**Caution:**

If the delivery mode fuse is removed from the position (1), the DTC related to the center information display (CID) is recorded. Be sure to clear the memory after installing the delivery mode fuse to the position (1).  Ref. to **COMMON (DIAGNOSTICS)>Clear memory>OPERATION.**

**Note:**

- Removing the delivery mode fuse from the position (2) deactivates the control during shipping (delivery mode).
- Park the vehicle on a level ground before performing this procedure.

- 3.** When the vehicle is delivered, the delivery mode fuse is normally placed in the position (2) as shown in the figure. However, if placed in the position (1), it may indicate that the headlight beam is deviated. In this case, perform the following procedures.
- (1) Park the vehicle on a level ground.
  - (2) Turn the ignition switch to OFF and remove the delivery mode fuse from the position (1).
  - (3) Install the delivery mode fuse in the position (2) and then turn the ignition switch to ON.
  - (4) Turn the ignition switch to OFF, install the delivery mode fuse in the position (1), and start the engine.

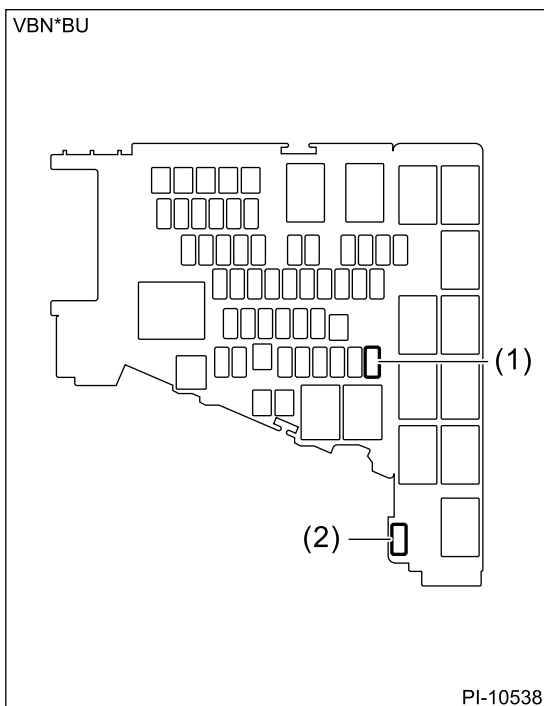

- (1) Delivery mode fuse inlet
- (2) Delivery mode fuse holder

#### 4. LOCK/UNLOCK AND OPEN/CLOSE OPERATION OF DOORS

- 1.** Using the key, lock and unlock the door several times to check for normal operation. Open and close the door several times for smooth movement.

**Caution:**

The mechanical key is a single groove type. Insert the mechanical key with the groove side facing the front side of the vehicle.

**Note:**

**For model with keyless access with push button start, check by using the mechanical key.**

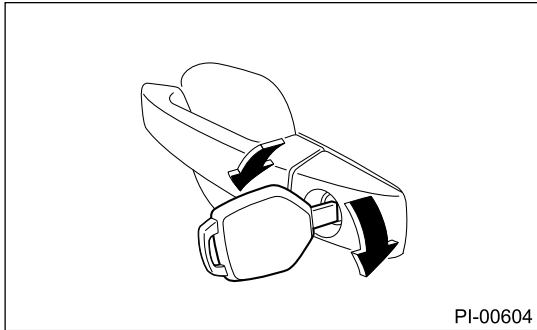

2. Completely close the door, and then check the smooth movement with operating door lock knob from lock to unlock several times. Set the door lock knob (A) to lock position. Pull the inner remote (B) to ensure that driver's and passenger's doors will open and rear doors will not open.

(A) Door lock knob

(B) Inner remote

3. Close all the doors, and then press the lock on power door lock switch at driver's side. Check that all doors lock.



4. Press the driver's power door lock switch to the unlock side. Check that all doors unlock.

5. Check that the passenger's power door lock switch locks and unlocks normally in the same manner.

(A) Lock

(B) Unlock

6. With ACC ON or ignition switch ON, open the driver's door. Press the lock side on power door lock switch. Check that the door is not locked.

## **5. CHILD SAFETY LOCK SYSTEM**

1. Set the child safety lock lever on both rear doors to the lock position.
2. Close the rear doors completely.
3. Check that the lock knobs of the rear doors are in the unlock position. Then, pull inner remote of rear doors to ensure that doors will not open.
4. Pull the outer handles of rear doors to ensure that doors will open.

(A) Unlock

(B) Lock

## **6. TRUNK OPEN/CLOSE OPERATIONS**

**1.** Press the trunk opener switch for approx. one second to check for normal operation of the trunk.

**2.** Open and close the trunk several times to check for smooth movement.

## **7. OPERATION CHECK OF TRUNK LID RELEASE HANDLE**

**Caution:**

**Do not check the trunk lid release handle when in the trunk. If the trunk lid release handle is defective, you may be trapped in.**

**1.** Use a flat tip screwdriver. Slide the screwdriver blade from the slit aperture of the lock assembly fully to the end until you hear a click. This places the latch in the locked position.

**2.** Make sure the latch is released by pulling the yellow trunk lid release handle in the direction of arrow.

## **8. FUEL LID LOCK/UNLOCK AND OPEN/CLOSE OPERATION**

**1.** Lock/unlock the door by keyless transmitter, access key or power door lock switch to check that the fuel lid locks and unlocks normally.

**2.** With unlock condition, push the fuel lid to check the fuel lid can be opened normally.

**3.** Operate the emergency release cable in the trunk to check the fuel lid can be unlocked normally.

(1) Remove the cover in the trunk.

(2) Operate the emergency release cable to check the fuel lid can be unlocked normally.

## 9. TOWING HOOK (EYEBOLT)

**Note:**

At factory shipment, the towing hook (eyebolt) is installed to the bumper face rear for securing the vehicle during transportation. Follow the procedure below to store it to the holder in the spacer center or spare tire.

1. Remove the towing hook (eyebolt) from the bumper face rear.

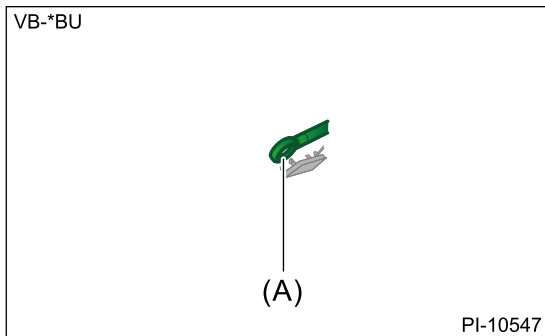

(A) Towing hook (eyebolt)

2. Store the towing hook (eyebolt) to the holder in the spacer center or spare tire.  [Ref. to PRE-DELIVERY INSPECTION > PRE-DELIVERY INSPECTION \(PDI\) PROCEDURE > ACCESSORY.](#)
3. Install the supplied cover hook rear to the bumper face rear.

## 10. ACCESSORY

Check that the following accessories are provided.

- Owner's manual
- Warranty booklet
- Maintenance note
- Spare key
- Key No. plate
- Jack
- Jack handle
- Wheel nut wrench
- Spare tire or puncture repair kit
- Towing hook (eyebolt)
- Screwdriver
  - Model with tire repair kit

(A) Screwdriver

(B) Wheel nut wrench

(C) Jack handle

(D) Towing hook (eyebolt)

(E) Jack

(F) Tire repair kit

- Model with spare tire

- (A) Jack handle
- (B) Wheel nut wrench

- (C) Screwdriver
- (D) Jack

- (E) Towing hook (eyebolt)
- (F) Spare tire

## 11. FRONT HOOD LOCK RELEASE

Operate the front hood lock release lever to check that the front hood is unlocked normally. (Turn the ignition switch to OFF when opening the front hood)

Operate the lever (A) and check that the front hood is opened normally.

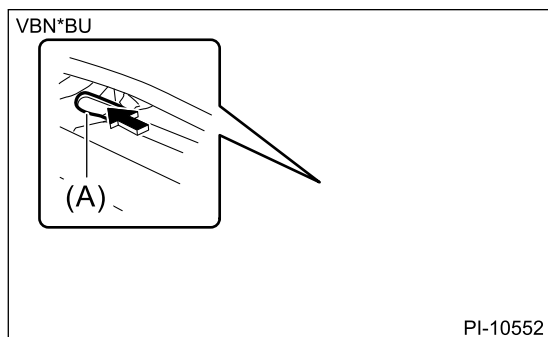

## 12. BATTERY

Check the battery terminals to make sure that there are no rust or corrosions due to electrolyte leaks. Check that the battery caps are securely tightened.

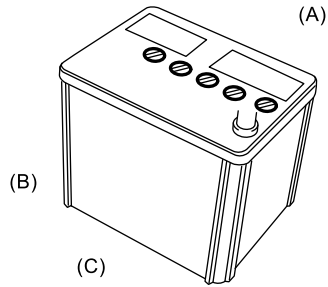

- (A) Cap
- (B) Upper level
- (C) Lower level

### 13. BRAKE FLUID

**Caution:**

- If the brake fluid is spilt over exhaust pipe, wipe it off completely with cloth to avoid emitting smoke or causing a fire.
- Always check the level using the specified direction because there is a partition in the reservoir tank.

Check that the brake fluid level is normal from a straight view or within 90° to the right and left forward. If the brake fluid amount is insufficient, carry out a brake line test to identify brake fluid leaks and check the brake operation. After that, refill the brake fluid tank with the specified type of brake fluid.  [Ref. to BRAKE>Brake Fluid>INSPECTION.](#)

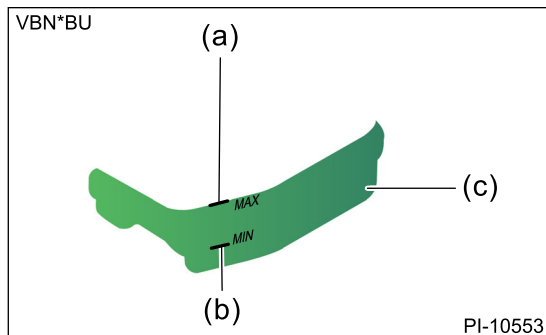

- (a) MAX. level
- (b) MIN. level
- (c) Brake fluid

### 14. ENGINE OIL

**Caution:**

- Vehicle components are extremely hot immediately after driving. Be wary of receiving burns from heated parts.
- If the engine oil is spilt over the engine, exhaust pipe or the under cover, completely wipe it off to avoid emission of smoke or causing a fire.

1. Park the vehicle on a level surface.
2. Pull out the oil level gauge, and wipe away the oil.
3. Reinsert the oil level gauge all the way. Be sure that the oil level gauge is correctly inserted and properly orientated.
4. Pull out the oil level gauge again, and check both sides of the oil level gauge. Use a lower side to determine the engine oil level. If the engine oil level is below the "L" line, check for oil leakage from engine, and add oil up to the "F" line.
5. Start the engine, and confirm that the oil pressure warning light goes off.
6. After turning off the engine, wait for five minutes or more until the engine oil returns back to the oil pan, then check the oil level.

**Note:**

**To prevent overfilling of engine oil, do not add engine oil above "F" line when the engine is cold.**

- (A) Oil level gauge
- (B) Oil filler cap
- (C) "F" line
- (D) "L" line
- (E) Approx. 1.0 L (1.1 US qt, 0.9 Imp qt)

## 15. TRANSMISSION GEAR OIL

**Caution:**

**If transmission gear oil is spilt over the exhaust pipe, wipe it off with a cloth to avoid emitting smoke or causing a fire.**

- Check for leakage of the transmission gear oil.
- Check that the transmission gear oil level is normal. If the amount of transmission gear oil is insufficient, check that no leaks are found. Then, add the necessary amount of specified transmission gear oil. Refer to "Transmission Gear Oil" of "MANUAL TRANSMISSION & DIFFERENTIAL (TY75)" for transmission gear oil inspection. [📄 Ref. to MANUAL TRANSMISSION AND DIFFERENTIAL\(TY75\)>Transmission Gear Oil>INSPECTION.](#)

## 16. CVTF

**Caution:**

**If the CVTF is spilt over exhaust pipe, wipe it off completely with cloth to avoid emitting smoke or causing a fire.**

Check for leakage of CVTF.

## 17. FRONT DIFFERENTIAL GEAR OIL (CVT MODEL)

**Caution:**

**If the front differential gear oil is spilt over exhaust pipe, wipe it off completely with cloth to avoid emitting smoke or causing a fire.**

Check for leakage of front differential gear oil.

## 18. REAR DIFFERENTIAL GEAR OIL

**Caution:**

**If the rear differential gear oil is spilt over exhaust pipe, wipe it off completely with cloth to avoid emitting smoke or causing a fire.**

Check for leakage of rear differential gear oil.

## 19. ENGINE COOLANT

**Caution:**

**If the engine coolant is spilt over exhaust pipe, wipe it off completely with cloth to avoid emitting smoke or causing a fire.**

Check that the engine coolant level on the reservoir tank is normal. If the amount of engine coolant is insufficient, check that no leaks are found. Then, add the necessary amount of coolant with the specified concentration.  [Ref. to COOLING\(H4DOTC\)>Engine Coolant>INSPECTION.](#)

## 20. CLUTCH FLUID

**Caution:**

- **If any clutch fluid is spilt on the exhaust pipe, wipe it off with a cloth to avoid emitting smoke or causing a fire.**
- **This reservoir tank has the brake fluid chamber and the clutch fluid chamber. When checking the clutch fluid level, always check the fluid from the clutch fluid chamber side where the tank hose is connected.**

Check that the clutch fluid level is normal. If the amount of clutch fluid is insufficient, check that no leaks are found. Then, add the necessary amount of specified clutch fluid.

(A) MAX. level

(B) MIN. level

(C) Reservoir tank

## 21. WINDOW WASHER FLUID

Check that the window washer fluid level is normal. If the amount of window washer fluid is insufficient, check that no leaks are found. Then, add the necessary amount of window washer fluid.

**Note:**

**If there is the vibration, water comes into the layer of air in the washer tank and the water level may drop. This is not a malfunction.**

## 22. FRONT HOOD LATCH

Close the front hood. Check that the front hood is completely latched.

## 23. KEYLESS ENTRY SYSTEM

Check the keyless entry system operations as follows:

- Fully open all the door windows.
- Remove the key from ignition switch, and then close all doors.
- Press the "LOCK" button momentarily on the keyless transmitter or the access key. Check that all the doors become locked, the buzzer sounds once, and the hazard lights flash once.
  
- Press the "UNLOCK" button momentarily on the keyless transmitter or the access key. Check that the driver's door is unlocked, the buzzer sounds twice, and the hazard lights flash twice.
- Also, within 5 seconds, press the "UNLOCK" button momentarily. Check that all the doors are unlocked, the buzzer sounds twice, and the hazard lights flash twice.

- Check that the buzzer sounds twice, and the hazard lights flash twice, when the trunk open button is held down to unlock the trunk lid.
  
- Press the PANIC button on the keyless transmitter or the access key. Check that the panic mode (the horn keeps sounding) is initiated. Also, check that this condition continues for 30 seconds or until when any of the buttons on the keyless transmitter or the access key are pressed.
  
- Momentarily press the "LOCK" button on the access key or the access key with one of the doors open. Check that the buzzer sounds 5 times, and the hazard light flashes 5 times to notify the door not being fully closed. Then, close all doors. Check if all doors are locked and buzzer sounds once and the hazard light flashes once.

#### **ALARM SOUND OPERATIONAL CHECK (7-INCH TWIN TYPE)**

**Note:**

**The system uses the buzzer and sounds the alarm when the door is locked or unlocked.  
The alarm sound can be turned OFF.**

- 1.** Close all doors and remove the key from the key cylinder.
- 2.** While holding down the "UNLOCK" side of the power door lock switch, insert the key in the key cylinder.

3. To turn the alarm sound from OFF to ON, select "Keyless Entry System" in "Car" item and then set "Audible Signal" to ON.
4. Within 10 seconds, insert and take out the key for 6 times or more, and within 10 seconds after that, open and close the driver's door.
5. With the door closed, check that the hazard light flashes 3 times and that the alarm sound has been turned OFF.
6. To turn the alarm sound from OFF to ON, perform this procedure again.
7. Check that the hazard light flashes 3 times and that the alarm has been turned ON.

**ALARM SOUND OPERATIONAL CHECK (11.6-INCH WIDE TYPE)**

**Note:**  
 The system uses the buzzer and sounds the alarm when the door is locked or unlocked.  
 The alarm sound can be turned OFF.

1. Press the "Settings" button in the center information display (CID).
2. Select "Keyless Entry System" in "Car" item and set "Audible Signal" to OFF.

**24. KEYLESS ACCESS SYSTEM**

**Caution:**

- When performing the check, check one access key at a time, separating individual keys.
- Do not leave any separated access keys in the vehicle.

**Note:**  
 The following inspections show the initial settings. When the settings are different from the initial settings, use Subaru Select Monitor to check the details of each setting for inspections.  Ref. to [BODY CONTROL\(DIAGNOSTICS\)>Data Monitor>LIST.](#)

- While carrying the access key, check that the room light illuminates when you move close to the front door handles of the vehicle whose doors are all locked.
- While carrying the access key, check that only the driver's door is unlocked or all doors are unlocked, the hazard lights flash, and the buzzer sounds by grasping the front door knob on the driver's side (touching the touch sensor (unlock)).
- While carrying the access key, check that all doors are unlocked, the hazard lights flash, and the buzzer sounds by grasping the front door knob on the passenger's side (touching the touch sensor (unlock)).
- While carrying the access key, check that all doors are locked and the hazard lights flash by touching the touch sensor (lock) of the front door.

**Note:**

- The buzzer sounds twice and the hazard lights flash twice when unlocking.
- The buzzer sounds once and the hazard lights flash once when locking.

(A) Touch sensor (lock)

- While carrying the access key, check that the trunk unlocks, the hazard lights flash twice, and the buzzer sounds twice when the trunk opener button is pressed.



(A) Trunk opener button

- Manually operate the access key button to check the unlock/lock of doors, and the flashing of hazard lights.
- Check for unlocking/locking by using the mechanical key attached to the access key.

**Caution:**

**The mechanical key is a single groove type. Insert the mechanical key with the groove side facing the front side of the vehicle.**

(A) Mechanical key

- Check that the warning buzzer sounds and the door-lock does not operate, when the doors are closed with the access key left in the vehicle and the touch sensor (lock) on door is touched.

**Caution:**

**Remove the mechanical key from the access key and hold the mechanical key.**

- With the access key in the trunk, check that the warning buzzer sounds when you close the trunk and that the trunk unlocks when you press the trunk opener button.

## 25. ALARM SYSTEM

### MODEL WITHOUT KEYLESS ACCESS WITH PUSH BUTTON START

**Note:**

**The following inspections show the initial settings. When the settings are different from the initial settings, use Subaru Select Monitor to check the details of each setting for inspections.  Ref. to BODY CONTROL(DIAGNOSTICS)>Registration Body Integrated Unit>OPERATION.**

1. Fully open all the door windows.
  2. Remove the key from the ignition switch and close all the doors including trunk and front hood.
  3. Press the "LOCK" button momentarily on the keyless transmitter. All doors are locked, and the security indicator light blinks faster for 30 seconds and blinks slowly twice repeatedly, then the alarm system is in set condition.
- 
4. Press the "UNLOCK" button momentarily on the keyless transmitter. The door of the driver's seat is unlocked, the security indicator light blinks, and the alarm system is disarmed.
- 
5. Press the "LOCK" button once on the keyless transmitter with one of the doors (including the trunk) open. Check that the buzzer sounds 5 times to give the door not fully closed warning. All doors (including trunk) are locked when they are closed, and the security indicator light flashes rapidly for 30 seconds and then flashes slowly twice repeatedly, then the alarm system is in set condition.

**Caution:**

**Perform the operation after the front hood is closed. If the front hood is open, the alarm system cannot be set.**

6. Press the "UNLOCK" button momentarily on the keyless transmitter. The door of the driver's seat is unlocked, the security indicator blinks, and the alarm system is disarmed.
7. With one of the doors (including the trunk) open, press the "LOCK" side of the power door lock switch. All doors (including trunk) are locked when they are closed, and the security indicator light flashes rapidly for 30 seconds and then flashes slowly twice repeatedly, then the alarm system is in set condition.

**Caution:**

**Perform the operation after the front hood is closed. If the front hood is open, the alarm system cannot be set.**

- Driver's side

- Passenger's side

8. Unlock a door using the inner lock knob or the key and open the door while the security system is in the set mode. Check if the alarm condition occurs (horn sounds continuously, hazard light blinks, security indicator light illuminates). Check if this condition lasts until any button of the keyless transmitter is pressed or until the ignition switch is turned to ON after inserting the key into the ignition switch.

**Note:**

**The alarm sounds for three minutes with the door open.**

9. When none of above is applicable, perform troubleshooting for the security system including front hood security system.

**MODEL WITH KEYLESS ACCESS WITH PUSH BUTTON START**

**Note:**

**The following inspections show the initial settings. When the settings are different from the initial settings, use Subaru Select Monitor to check the details of each setting for inspections.  Ref. to BODY CONTROL(DIAGNOSTICS)>Registration Body Integrated Unit>OPERATION.**

1. Fully open all the door windows.
2. Close all the doors, trunk and front hood.
3. Press the "LOCK" button momentarily on the access key. All doors are locked, and the security indicator light blinks faster for 30 seconds and blinks slowly twice repeatedly, then the alarm system is in set condition.

4. Press the "UNLOCK" button momentarily on the access key. The door of the driver's seat is unlocked, the security indicator light blinks, and the alarm system is disarmed.

5. Press the "LOCK" button once on the access key with one of the doors (including the trunk) open. Check that the buzzer sounds 5 times to give the door not fully closed warning. All doors (including trunk) are locked when they are closed, and the security indicator light flashes rapidly for 30 seconds and then flashes slowly twice repeatedly, then the alarm system is in set condition.

**Caution:**

**Perform the operation after the front hood is closed. If the front hood is open, the alarm system cannot be set.**

6. Press the "UNLOCK" button momentarily on the access key. The door of the driver's seat is unlocked, the security indicator blinks, and the alarm system is disarmed.

7. With one of the doors (including the trunk) open, press the "LOCK" side of the power door lock switch. All doors (including trunk) are locked when they are closed, and the security indicator light flashes rapidly for 30 seconds and then flashes slowly twice repeatedly, then the alarm system is in set condition.

**Caution:**

**Perform the operation after the front hood is closed. If the front hood is open, the alarm system cannot be set.**

- Driver's side

- Passenger's side

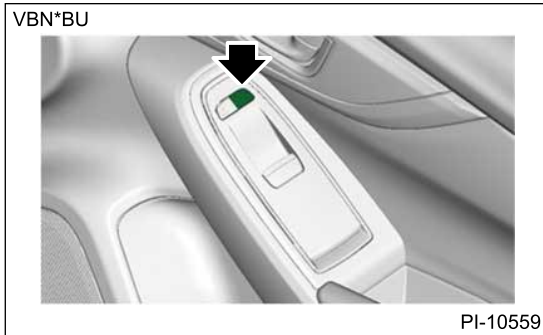

8. Unlock a door using the mechanical key and open the door while the security system is in the set mode. Check if the alarm condition occurs (horn sounds continuously, hazard light blinks, security indicator light illuminates). Check if this condition lasts until any button on the access key is pressed or until the ignition switch is turned to ACC.

**Caution:**

**The mechanical key is a single groove type. Insert the mechanical key with the groove side facing the front side of the vehicle.**

**Note:**

**The alarm sounds for three minutes with the door open.**

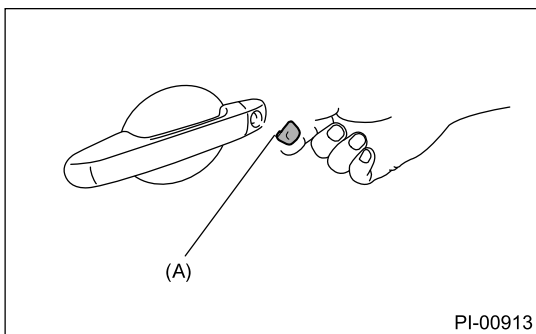

(A) Mechanical key

9. When none of above is applicable, perform troubleshooting for the security system including front hood security system.

## 26. SEAT

1. Check the seat surfaces for stains or dirt.

2. Check that each seat provides full functionality in sliding, reclining, lifter, folding, tilting, and lumbar. Check all available functions of the rear seat such as armrest and backrest tilt knob.
3. Check that the seat heater system operates normally. (Model with seat heater)
4. Check the passenger's seat and rear seat occupant detection system.
  - (1) Empty the passenger's seat and turn the ignition switch to ON.
  - (2) Check that the passenger airbag ON/OFF indicator lights both turn on simultaneously for approximately six seconds, and after turning off for two seconds, only the OFF light illuminates.

(3) Sit at each position of rear seat, and check that the rear seat belt warning light illuminates. (If no passenger is on the rear seat, the seat belt warning light for rear seat does not operate.)

(4) Fasten the rear seat belt at each position, and check that the rear seat belt warning light turns off.

5. With a person weighing approximately 70 kg (155 lb) or more sitting in the passenger's seat, check whether the ON light of the passenger's airbag ON/OFF indicator illuminates or not.
6. Have the passenger get out of the passenger's seat, and check whether the OFF light of the passenger side airbag ON/OFF indicator illuminates.

## **27. SEAT BELT**

1. Check installation condition of seat belt.
2. Pull out the seat belt and then release it. Check that the belt retracts smoothly.
3. Check seat belt warning function.
  - (1) Turn the ignition switch to ON with the driver's, passenger's and rear seat belts detached.
  - (2) Check the driver's and passenger's seat belt warning light blink for approx. 6 seconds and the buzzer sounds intermittently.
  - (3) Then, check the seat belt warning light illuminates and blinks repeatedly at a cycle of approx. 15 seconds. (If no passenger is on the passenger's seat, the seat belt warning light on passenger's seat does not operate.)
  - (4) Check that the rear seat belt warning light illuminates. (If no passenger is on the rear seat, the seat belt warning light for rear seat does not operate.)

(5) Then, check that the rear seat belt warning light turns off when the rear seat belts are fastened.

## 28. TPMS (U.S. MODEL)

1. Adjust the tire pressure.
2. Turn the ignition switch to ON, and check TPMS warning light for normal operation.
  - Normal operation (IG ON (light check))

3. If the TPMS warning light display does not operate normally, check and repair the system.  [Ref. to TIRE PRESSURE MONITOR\(DIAGNOSTICS\)>Basic Diagnostic Procedure.](#)

## 29. HORN

Check that the horn sounds.

## 30. HAZARD LIGHT SYSTEM

Check that the hazard lights illuminate.

## 31. SPOT MAP LIGHT

After installing the delivery mode fuse, check if the spot map light illuminates or goes off normally.

## 32. GROMMET

Install the grommet provided in the rear seat to the rear tie-down hole.

### Caution:

**Make sure that the rear tie-down hole is firmly plugged with the grommet. Otherwise, dust, smell, etc. may come into the passenger compartment indirectly from the rear quarter, via the side sill from the rear tie-down hole.**

(1) Grommet

## 33. DELIVERY MODE

1. Turn the ignition switch to OFF and install the delivery mode fuse (A).

**Caution:**

**Do not use any fuses that are installed on the vehicle.**

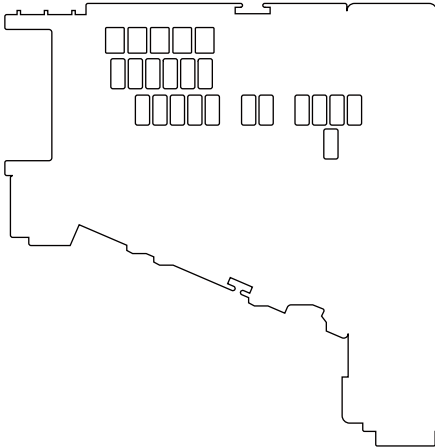

2. Turn the ignition switch to ON and check that the malfunction indicator light starts blinking.
3. If the malfunction indicator light blinks, return the ignition switch to OFF.
4. Remove the delivery mode fuse.
5. Then, turn the ignition switch to ON again.
6. Make sure that the malfunction indicator light is off. If the malfunction indicator light blinks, carry out an engine diagnosis.  [Ref. to ENGINE \(DIAGNOSTICS\)\(H4DOTC\)>Basic Diagnostic Procedure.](#)
7. Clear the memory.

**Caution:**

**If the delivery mode fuse is removed, the DTC related to the center information display (CID) is recorded. For the installation procedure of the delivery mode fuse, be sure to refer to "FUSE INSTALLATION" in "Pre-delivery Inspection".**  [Ref. to PRE-DELIVERY INSPECTION>PRE-DELIVERY INSPECTION \(PDI\) PROCEDURE > FUSE INSTALLATION.](#)

## 34. IMMOBILIZER SYSTEM

1. Check that the engine starts with all keys that are equipped on vehicle.
2. Check that the security indicator light blinks in 60 seconds after turning the ignition switch from ON to ACC or to OFF, and immediately after removing the key. (Model without keyless access with push button start)
3. Immediately after turning ignition switch from ON to OFF, and immediately after opening/closing a door while the ignition switch is in ON or ACC with the engine stopped and the access key is outside the vehicle, check that the security indicator light is blinking. (Model with keyless access with push button start)

**Note:**

If malfunctions occur, refer to "Basic Diagnostic Procedure" of "IMMOBILIZER (DIAGNOSTICS)".  [Ref. to IMMOBILIZER \(DIAGNOSTICS\)>Basic Diagnostic Procedure.](#)

(1) Security indicator light

## 35. PUSH BUTTON START FUNCTION

### MT model

1. Get into the vehicle while carrying the access key, with the clutch pedal OFF, and check that it cycles through ignition switch OFF → ACC ON → ignition switch ON → ignition switch OFF every time the push button ignition switch is pressed, and that the indicator light for the push button ignition switch is illuminated in orange when the ignition switch is in the ACC ON and ignition switch ON positions.
2. Get into the vehicle while carrying the access key, with the clutch pedal ON, check that the indicator light for the push button ignition switch is illuminated in green.
3. Get into the vehicle while carrying the access key, with the clutch pedal ON, check that the engine starts when you press the push button ignition switch.
4. With the vehicle stopped and the engine running, check that the engine stops when you press the push button ignition switch.

### CVT MODEL

1. Get into the vehicle while carrying the access key, with the vehicle in "P range" and the brake pedal OFF, and check that it cycles through ACC → ignition switch ON → ignition switch OFF every time the push button ignition switch is pressed, and that the indicator light for the push button ignition switch is illuminated in orange when the ignition switch is in the ACC and ignition switch ON positions.
2. Get into the vehicle while carrying the access key, with the vehicle in "P range" and the brake pedal ON, check that the indicator light for the push button ignition switch is illuminated in green.

**Note:**

**While the select lever button is being pressed, the indicator light of the push button ignition switch does not illuminate in green even if the shift position is in the "P range".**

3. Get into the vehicle while carrying the access key, with the vehicle in "P range" and the brake pedal ON, check that the engine starts when you press the push button ignition switch.
4. With the vehicle stopped, the engine running and in "P range", check that the engine stops when you press the push button ignition switch.

5. With the vehicle stopped, the engine running and in "N range", check that the engine stops when you press the push button ignition switch, and it cycles through ACC → ignition switch ON each time you press the push button ignition switch.

## 36. STARTING CONDITION

Start the engine and check that the engine starts smoothly. If the battery voltage is low, recharge or replace the battery. If any noises are observed, immediately stop the engine and check and repair the abnormal components.

## 37. EXHAUST

Check that there are no abnormal exhaust noises. Check that no leaks are found.

## 38. INDICATOR LIGHT AND WARNING LIGHT

Check that all indicator lights and warning lights are operating correctly.  [Ref. to INSTRUMENTATION/DRIVER INFO>Combination Meter System>INSPECTION.](#)

## 39. HEATER & VENTILATION

Operate the heater & ventilation system to check for normal airflow outlet control, air inlet control, airflow capacity and heating performance.

## 40. CENTER INFORMATION DISPLAY (CID)

Check that the following functions operate normally with touch panel operations of the center information display (CID).

### 1. Air conditioner

Operate the air conditioner. Check that the A/C compressor operates normally and enough cooling is provided.

#### Note:

**To prevent the insufficient lubrication of the air conditioner, operate the air conditioner for five minutes at idling.**

### 2. Model without navigation system

- (1) Check all display functions for normal operation. (Refer to the operation manual.)
- (2) Check if the AM/FM/SXM (only for model with SXM function) radio broadcasting can be heard.
- (3) Check that all the radio functions work properly and the noise level is normal.
- (4) Check the CD player (when installed) and media for normal operation.
- (5) Check that the center information display (CID) is installed into the instrument panel without looseness.
- (6) Check that the rearview camera operates normally.

### 3. Model with navigation system

- (1) Check all display functions for normal operation. (Refer to the operation manual.)
- (2) Check if the AM/FM/SXM (only for model with SXM function) radio broadcasting can be heard.
- (3) Check that all the radio functions work properly and the noise level is normal.
- (4) Check that the navigation system operates normally.
- (5) Check the CD player (when installed) and media for normal operation.
- (6) Check that the center information display (CID) is installed into the instrument panel without looseness.

(7) Check that the rearview camera operates normally.

## 41. TELEMATICS SYSTEM

- Check that the indicator light on the overhead console goes off.
- Perform the Bluetooth connection procedure between head unit (without navigation) and smartphone, and adjust the time.  [Ref. to REPAIR CONTENTS>NOTE > Bluetooth CONNECTION PROCEDURE BETWEEN HEAD UNIT \(AUDIO WITHOUT NAVIGATION\) AND SMARTPHONE.](#)

**Note:**

**This procedure is required to prevent communication error while the service appointment scheduler function is in use.**

## 42. USB POWER SUPPLY

Check that the USB power supply operates normally.

## 43. ACCESSORY POWER SUPPLY SOCKET

Check the operation of the accessory power supply socket.

## 44. LIGHTING SYSTEM

1. Check the headlight operations. Also when the push button ignition switch is OFF or the key is pulled out, check that the headlight illuminates.
2. When the lighting switch is turned to OFF position, check that it automatically returns to AUTO position. (For C0)
3. Check the stop light operation.
4. Check other lights for normal operations.

## 45. VDC

1. With the engine running, press the VDC OFF switch for a short period (approx. 1 sec. or less), and check that the "TRACK" and "VDC OFF" indicator lights illuminate and that they turn off when the switch is operated again.
2. With the engine running, press and hold the VDC OFF switch for a long period (approx. 2 sec. or more), and check that the "VDC OFF" indicator light illuminates and that it turns off when the switch is pressed again for a short period.

## 46. ILLUMINATION CONTROL

Check that the illumination control operates normally.

## 47. WINDOW WASHER SYSTEM

Check that the window washer system injects window washer fluid to the specified area of the windshield.  [Ref. to WIPER AND WASHER SYSTEMS>Front Washer>INSPECTION.](#)

## 48. WIPER SYSTEM

Check that the front wiper operates normally.

## 49. WIPER DEICER

Check that the wiper deicer operates normally.

**Note:**

**When an ambient temperature is 5°C or more, wiper deicer operation is canceled. Press the switch for 3 seconds or more to perform the compulsory operation.**

## 50. POWER WINDOW

- Operate the power window switches one by one to check that each of the power windows goes up and down without noises.
- Check that AUTO UP/AUTO DOWN operate properly by the power window switches on driver's seat, passenger's seat and rear seat.

**Caution:**

**If battery has been removed, AUTO UP does not operate properly because initialized. In this case, perform the power window system initialization and check that AUTO UP operates properly.**

**Note:**

**Check the power window if the door glass does not open/close automatically.  Ref. to POWER WINDOW(DIAGNOSTICS) >Basic Diagnostic Procedure.**

## 51. SUNROOF

Check that the sunroof operates normally.

## 52. REAR WINDOW DEFOGGER SYSTEM

Press the rear window defogger switch and check that the light inside the switch is activated for approx. 15 minutes and then the rear window defogger automatically turns to OFF.

## 53. DOOR MIRROR

- Check that the remote control mirror operates normally.
- Check that the heated door mirror operates normally.

## 54. ROOM MIRROR

Check that the automatic anti-glare function operates normally.

## 55. BLIND SPOT DETECTION / REAR CROSS TRAFFIC ALERT (BSD/RCTA)

1. Check that the BSD/RCTA system is activated and deactivated correctly.
  - (1) Press the "Settings" button in the center information display (CID) and set "BSD/RCTA" in "Car" item to OFF.
  - (2) Check if the "BSD/RCTA OFF indicator light" in the combination meter illuminates.
  - (3) Press the "Settings" button in the center information display (CID) and set "BSD/RCTA" in "Car" item to ON.
  - (4) Check that the indicators of the right and left side door mirrors illuminate and go off, and then "BSD/RCTA OFF indicator light" goes out in the combination meter.
  - (5) Check that the BSD/RCTA error message is not displayed.
2. Check the bumper face rear around the radar sensor for dirt, scratch, affixed stickers and poor paint coating.
  - If any dirt is found, clean it off while being careful not to damage the bumper face rear.

- If any stickers are affixed, remove them while being careful not to damage the bumper face rear.
- If the bumper face rear is damaged or has poor paint coating, refer to "CAUTION" in "Blind Spot Detection/Rear Cross Traffic Alert (DIAGNOSTICS)".  [Ref. to Blind Spot Detection/Rear Cross Traffic Alert \(DIAGNOSTICS\)>General Description>CAUTION.](#)

(A) Radar sensor

## 56. Reverse Automatic Braking (RAB)

1. Check that the RAB system is activated and deactivated correctly.
  - (1) Start the engine and let the engine idle for 6 seconds or more, and then shift the select lever to "R range".
  - (2) Check that "RAB" and "RAB OFF" in the combination meter turn off.
  - (3) Check that the RAB warning is displayed on the rearview camera screen of the navigation system and "RAB" and "P△" indicators illuminate in green.
  - (4) Press and hold "RAB" displayed on the screen, and check that "RAB OFF" illuminates in the combination meter when switching to "RAB OFF" or during "RAB OFF".
  - (5) Press and hold "RAB" displayed on the screen again, and check that "RAB OFF" turns off in the combination meter when switching to "RAB ON".
  - (6) Press and hold "P" displayed on the screen, and check that it switches to "P OFF".
  - (7) Press and hold "P" displayed on the screen again, and check that it switches to "P ON".
2. Check the sonar sensor installed on the bumper face rear for parts missing, dirt, scratch, foreign objects, etc.
  - The sensor surface must not stick out or sink in at 0.5 mm or more from the bumper face rear surface.  
If the sensor surface largely sinks in, the sensor may not engaged in the holder behind the bumper face rear. In this case, check the installation condition of the sensor after removing the bumper face rear.
  - Make sure that there are no foreign objects (tape, stickers, dust or dirt) on the sonar sensor surface.  
If there is a layer of foreign objects on the sensor surface, remove completely so that no residue remains.

(A) Sonar sensor

## 57. PARKING BRAKE

### MT model

Check that the parking brake operates normally. When pulling the parking brake lever with a force of 200 N (20.4 kgf, 45 lbf), check that the lever stroke of parking brake lever is 7 to 8 notches.

### CVT MODEL

Check the parking brake operates properly by depressing brake pedal and operating the electronic parking brake switch.

## 58. DIAGNOSTIC TROUBLE CODE (DTC) CHECK

Read the diagnostic trouble code and check that the diagnostic trouble code is not detected.

If any diagnostic trouble code is detected, clear all.

### 1. Read diagnostic trouble code

**Note:**

For detailed operation procedures, refer to "Help" of application.

### 2. Clear memory

**Note:**

For detailed operation procedures, refer to "Help" of application.

## 59. EyeSight ASSIST MONITOR

Check that the indicator light illuminates with the ignition ON.

## 60. AUTO VEHICLE HOLD (AVH) SYSTEM

Check that the AVH system is activated and deactivated correctly.

- Press the "Car Settings" button in the center information display (CID) and set "Auto Vehicle Hold (AVH)" in "Vehicle Control" item to ON to check that the AVH ON indicator in the combination meter illuminates. (7-inch twin type)
- Press the "Settings" button in the center information display (CID) and set "Auto Vehicle Hold (AVH)" in "Car" item to ON. Check if the AVH ON indicator in the combination meter illuminates. (11.6-inch wide type)
- Check that the vehicle hold condition is still maintained when the following conditions are met and the brake pedal is released.
  - Engine is running
  - Select lever is in position other than "P range"
  - Seat belt is fastened

- Driver's door is closed
- Check if the AVH indicator blinks in the combination meter while in the vehicle hold condition.
- Check that the vehicle hold condition is deactivated by depressing the accelerator pedal in the vehicle hold condition. Depress the brake pedal after checking deactivation.
- After the inspection, press the AVH switch in the center information display (CID) with the brake pedal depressed, and check that the AVH ON indicator goes off in the combination meter.
- After the inspection, press the "Car Settings" button in the center information display (CID) with the brake pedal depressed, and set "Auto Vehicle Hold (AVH)" in "Vehicle Control" item to OFF. Check if the AVH ON indicator in the combination meter goes off. (7-inch twin type)
- After the inspection, press the "Settings" button in the center information display (CID) with the brake pedal depressed, and set "Auto Vehicle Hold (AVH)" in "Car" item to OFF. Check if the AVH ON indicator in the combination meter goes off. (11.6-inch wide type)

## 61. MULTI INFORMATION DISPLAY (MID) SYSTEM

Check that the multi information display (MID) switch operates normally.

(A) Multi information display  
(MID) switch

## 62. BRAKE TEST

Check the foot brake for normal operations.

### Note:

**On the model with brake assist mechanism, the brake pedal feels lighter when the brake pedal is depressed hard or quickly. However, those are not malfunction but the phenomena that occur when the brake assist mechanism functions properly.**

## 63. SHIFT CONTROL

### • MT model

- 1.** Check for smooth operation to each position. Especially, shift to 5th  $\longleftrightarrow$  6th and to reverse, and check for any stuck.
- 2.** Check the slider returns to the original position by shifting to the reverse and then back in neutral while pulling up the slider.
- 3.** If the shifting operation is not smooth, readjust the exposed length (a) of MT gear select cable by referring to the following figure.

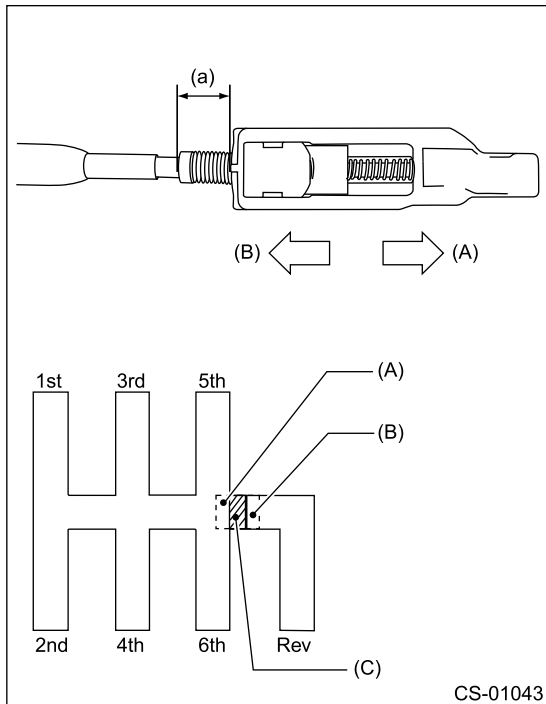

- (a) Exposed length of MT gear select cable
- (A) Extend direction of exposed length of MT gear select cable
- (B) Shorten direction of exposed length of MT gear select cable
- (C) Specification of exposed length (a)

- If 5th or 6th gear cannot be selected (pressing to the reverse lock bracket):  
→ Extend the exposed length (a) of MT gear select cable.
- If the gear shift lever does not move along the cranking line when it is operated from 4th → 5th gear:  
→ Shorten the exposed length (a) of MT gear select cable.

### CVT MODEL

- 1.** Turn the ignition switch to ON.
- 2.** While brake pedal is not depressed, check if the select lever does not move from "P range".
- 3.** While brake pedal is depressed, check if the select lever moves from "P range".
- 4.** Set the selector lever to each selector position and check the shifting while driving the vehicle. Operate the paddle shift at manual mode and check the shifting while driving the vehicle.

Selector position	Gear position							
	1st	2nd	3rd	4th	5th	6th	7th	8th
D	Continuously variable speed change							
Manual mode	OK	OK	OK	OK	OK	OK	OK	OK

5. Set the select lever to other than "P range". (Model without keyless access with push button start)
6. When the ignition switch is turned to OFF, check if the ignition key switch cannot be removed.  
(Model without keyless access with push button start)

## 64. CRUISE CONTROL

Operate the cruise control system. Check that the system is activated and deactivated correctly. (Cruise control does not operate when the control during shipping (delivery mode) is activated)

## 65. EyeSight

- Operate the EyeSight system. Check that the system is activated and deactivated correctly.
- Check the glass in front of stereo camera for dirt and stickers.
- Check the lens and lens hood of the stereo camera for dirt or scratches.
- According to the "CAUTION", check the windshield glass and dashboard in front of stereo camera to make sure that no aftermarket part is adhered or attached in the prohibited area.  [Ref. to CAUTION > CHECK WINDSHIELD GLASS INCLUDING PROHIBITED AREA FOR MODEL WITH EyeSight.](#)

## 66. POWER STEERING SYSTEM

Check that the steering warning light illuminates when the ignition switch is turned to ON, and that the steering warning light goes off after the engine is started.

## 67. FLUID LEAKAGE

Check entire areas of the vehicle for any trace of engine coolant/engine oil/gear oil/CVTF/brake fluid leaks.

## 68. WATER LEAK TEST

Spray the vehicle with water using a hose and check that no water enters the passenger compartment.

- Before performing the water leakage test, remove anything that may obstruct the operation or which must be kept dry.
- Close all the windows and doors securely. Close the front hood and trunk before starting the test.

- Connect a hose to a tap, and spray water on the vehicle. The rate of water spray must be approx. 20 — 25 L (5.3—6.6 US gal, 4.4—5.5 Imp gal) per minute.

When spraying water on areas adjacent to the floor and wheel house, increase the pressure. When spraying water on areas other than the floor and wheel house, decrease the pressure. But the force of water must be made strong occasionally by pressing the end of the hose.

**Note:**

**Be sure to keep the hose at least 10 cm (3.9 in) away from vehicle.**

Check the following areas.

- Front window and body framework mating portion
- Door mating portions
- Glass mating portions
- Rear window and body framework mating portion
- Around roof drips

If any dampness in the compartments is discovered after the water has been applied, carefully check all the areas that may have possibly contributed to the leak.

## 69. APPEARANCE 2

1. When vehicle body is covered with protective film, peel it off.

**Note:**

- **Use of steam facilitates peeling off the protective film.**
- **Vehicle left for an extended periods or at low temperatures, spray the vehicle with water heated to 50 — 60 °C (122 — 140 °F) to raise its surface temperature before peeling off the protective film. Do not use the water heated to over 60°C (140°F).**
- **If the adhesive remains exist on the coated surface, soak a flannel rag, etc. with a small amount of coating wax or solvent such as oil benzene and IPA, put the soaked rag on the remains lightly, and then wipe them off with the rag.**
- **Keep solvent from touching the resin or rubber parts. Do not use coating wax or solvents while the component surface temperature is hot due to hot weather etc.**
- **If the coated surface is swollen out due to seams or moisture, expose the vehicle to the sunlight for a few hours or heat the seam and swollen portions using a dryer etc.**
- **Follow all government and local regulations concerning disposal of refuse when disposing of protective film.**

2. Check the whole vehicle body for flaking paint, damage by transportation, corrosion, dirt, cracks or blisters.

**Note:**

- **It is better to determine an inspection pattern in order to avoid missing an area, since the total inspection area is wide.**
- **Do not repair the body paint unless absolutely necessary. Also, if the vehicle is in need of repair to remove scratches or corroded paint, the repair area must be limited to the minimum. Re-painting and spray painting must be avoided as much as possible.**

3. Check each window glass for scratches carefully. Slight damage may be removed by polishing with glass polishing agent (cerium oxide, etc.). (Fill a cap half with glass polishing agent (cerium oxide, etc.) and add warm water to it. Then agitate the content until it turns to wax. Apply this wax to a soft cloth, and polish the glass with it.)
4. Check each portion of the vehicle body and underside components for the formation of rust. If rust is discovered, remove it with sandpaper of #80 to #180 and treat the surface with rust preventive.

After this treatment is completed, flush the portion thoroughly, and prepare the surface for repair painting.

- 5.** Check each portion of body and all of the exterior parts for deformation or distortion. Also, check each light lens for cracks.
- 6.** Peel the protective tape, protective film, vinyl wrapping and identification seal attached to the following places.
  - Seat
  - Door trim (protective tape)
  - Floor carpet
  - Instrument panel (identification seal, protective tape)
  - Rear shelf (protective tape)
  - Cover mount (identification seal)

# PERIODIC MAINTENANCE SERVICES

***PM***

---

1. General Description
2. Schedule
3. Engine Oil
4. Engine Oil Filter
5. Spark Plug
6. V-belt
7. Fuel Line
8. Fuel Filter
9. Air Cleaner Element
10. Cooling System
11. Engine Coolant
12. Clutch System
13. Transmission Gear Oil
14. CVTF
15. Front & Rear Differential Gear Oil
16. Brake Line
17. Brake Fluid
18. Disc Brake Pad and Disc
19. Parking Brake
20. Suspension
21. Wheel Bearing
22. Axle Boots & Joints
23. Tire Inspection and Rotation
24. Steering System (Power Steering)
25. A/C Filter

## PERIODIC MAINTENANCE SERVICES > General Description

### GENERAL DESCRIPTION

---

Be sure to perform periodic maintenance in order to maintain vehicle performance and find problems before they occur.

PERIODIC MAINTENANCE SERVICES > Schedule

**MAINTENANCE SCHEDULE**

**1. MODEL WITH US SPECIFICATION**

Maintenance item		Maintenance interval													Remarks
		[Number of months or km (miles), whichever occurs first]													
	Months	3	6	12	18	24	30	36	42	48	54	60	66	To be continued to the next table.	
	×1,000 km	4.8	9.6	19.2	28.8	38.4	48	57.6	67.2	76.8	86.4	96	105.6		
	×1,000miles	3	6	12	18	24	30	36	42	48	54	60	66		
1	Engine oil		R	R	R	R	R	R	R	R	R	R	R		Note 1.
2	Engine oil filter		R	R	R	R	R	R	R	R	R	R	R		Note 1.
3	Spark plug											R			
4	V-belt						I					I			
5	Fuel line						I					I			Note 4. Note 5.
6	Fuel filter														Note 2. Note 5.
7	Air cleaner element						R					R			Note 6.
8	Cooling system						I					I			Note 8.
9	Engine coolant		I	I	I	I	I	I	I	I	I	I	I		Note 8. Note 9.
10	Clutch system			I		I		I		I		I			
11	Transmission gear oil						I					I			
12	CVTF						I					I			

<b>Maintenance item</b>		<b>Maintenance interval [Number of months or km (miles), whichever occurs first]</b>														
1 3	Front & rear differential gear oil						I						I			
1 4	Brake line			I		I		I		I			I			Note 4.
1 5	Brake fluid / clutch fluid (MT model only)						R						R			Note 3.
1 6	Disc brake pad and disc			I		I		I		I			I			Note 4.
1 7	Parking brake			I		I		I		I			I			Note 4.
1 8	Suspension			I		I		I		I			I			Note 4.
1 9	Wheel bearing												I			
2 0	Axle boots and joints			I		I		I		I			I			Note 4.
2 1	Tire rotation	Perform every 10,000 km (6,000 miles)													Note 7.	
2 2	Steering system (power steering)			I		I		I		I			I			Note 4.
2 3	A/C filter	Replace every 12 months or 19,200 km (12,000 miles)													Note 6.	

Maintenance item		Maintenance interval [Number of months or km (miles), whichever occurs first]												Remarks	
	Months	Continued from previous table	72	78	84	90	96	102	108	114	120	126	132		
	×1,000 km		115.2	124.8	134.4	144	153.6	163.2	172.8	182.4	192	201.6	211.2		
	×1,000miles		72	78	84	90	96	102	108	114	120	126	132		
1	Engine oil		R	R	R	R	R	R	R	R	R	R	R	Note 1.	
2	Engine oil filter		R	R	R	R	R	R	R	R	R	R	R	Note 1.	
3	Spark plug										R				
4	V-belt					I					I				
5	Fuel line					I					I			Note 4. Note 5.	
6	Fuel filter		R											Note 2. Note 5.	
7	Air cleaner element					R					R			Note 6.	
8	Cooling system					I					I			Note 8.	
9	Engine coolant		I	I	I	I	I	I	I	I	I	I	I	Note 8. Note 9.	
10	Clutch system		I		I		I		I		I		I		
11	Transmission gear oil					I					I				
12	CVTF					I					I				
13	Front & rear differential gear oil					I					I				

<b>Maintenance item</b>		<b>Maintenance interval</b> <b>[Number of months or km (miles), whichever occurs first]</b>												
1 4	Brake line		I		I		I		I		I		I	Note 4.
1 5	Brake fluid / clutch fluid (MT model only)					R							R	Note 3.
1 6	Disc brake pad and disc		I		I		I		I		I		I	Note 4.
1 7	Parking brake		I		I		I		I		I		I	Note 4.
1 8	Suspension		I		I		I		I		I		I	Note 4.
1 9	Wheel bearing										I			
2 0	Axle boots and joints		I		I		I		I		I		I	Note 4.
2 1	Tire rotation	Perform every 10,000 km (6,000 miles)											Note 7.	
2 2	Steering system (power steering)		I		I		I		I		I		I	Note 4.
2 3	A/C filter	Replace every 12 months or 19,200 km (12,000 miles)											Note 6.	

Symbol

R: Replace

I: Inspection

P: Perform

**Note:**

- 1. When the vehicle is used under severe conditions, replace the engine oil and engine oil filter every 3 months or 4,800 km (3,000 miles).**
- 2. When the vehicle is used under extremely low or high temperature conditions, the fuel filter may become dirty. Therefore, it should be replaced frequently.**
- 3. When the vehicle is used in high humidity area or mountain area, replace the brake fluid every 15 months or 24,000 km (15,000 miles).**
- 4. When the vehicle is used under severe conditions, check every 6 months or 9,600 km (6,000 miles).**
- 5. This inspection procedure is not required to maintain emission warranty eligibility and it does not affect the manufacturer's obligations under EPA's in-use compliance program.**
- 6. When the vehicle is used under extremely dusty conditions, the air cleaner element and A/C filter should be replaced more often.**
- 7. A tire should be replaced when the tread wear indicator appears as a solid band across the tread. The indicators appear when the remaining tread has been worn to 1.6 mm (0.063 in) or less.**
- 8. To prevent cooling system leakage, be sure to add SUBARU genuine cooling system conditioner when replacing coolant.**
- 9. Replace after the first 11 years or 220,000 km (137,500 miles), and every six years or 120,000 km (75,000 miles) thereafter.**

**EXAMPLES OF SEVERE CONDITIONS**

- a. Drive repeatedly at short distance. (Maintenance items 1 and 2)
- b. Drive repeatedly on bumpy muddy road. (Maintenance items 14, 15, 17 and 18)
- c. Drive repeatedly in dusty conditions. (Maintenance items 7 and 23)
- d. Drive in extremely cold weather. (Maintenance items 1, 2, 16, 20 and 22)
- e. Area where salt or other corrosive used. (Maintenance items 5, 14, 15, 16, 17, 18 and 20)
- f. Coastal area. (Maintenance item 5)

## PERIODIC MAINTENANCE SERVICES > Engine Oil

### **INSPECTION**

---

Refer to "Engine Oil" of "LUBRICATION (H4DOTC)" for engine oil inspection procedure. [Ref. to LUBRICATION\(H4DOTC\)>Engine Oil>INSPECTION.](#)

## PERIODIC MAINTENANCE SERVICES > Engine Oil

### **REPLACEMENT**

---

Refer to "Engine Oil" of "LUBRICATION (H4DOTC)" for engine oil replacement procedure. [Ref. to LUBRICATION\(H4DOTC\)>Engine Oil>REPLACEMENT.](#)

## PERIODIC MAINTENANCE SERVICES > Engine Oil Filter

### REPLACEMENT

---

Refer to "Oil Filter" of "LUBRICATION (H4DOTC)" for engine oil filter replacement. [Ref. to LUBRICATION\(H4DOTC\)>Oil Filter.](#)

## PERIODIC MAINTENANCE SERVICES > Spark Plug

### REPLACEMENT

---

Refer to "Spark Plug" of "IGNITION (H4DOTC)" for spark plug replacement procedure. [Ref. to IGNITION\(H4DOTC\)>Spark Plug.](#)

## PERIODIC MAINTENANCE SERVICES > V-belt

### INSPECTION

---

Refer to "V-belt" of "MECHANICAL (H4DOTC)" for V-belt inspection procedure. [Ref. to MECHANICAL\(H4DOTC\)>V-belt>INSPECTION.](#)

## PERIODIC MAINTENANCE SERVICES > V-belt

### REPLACEMENT

---

Refer to "V-belt" of "MECHANICAL (H4DOTC)" for V-belt replacement procedure. [Ref. to MECHANICAL\(H4DOTC\)>V-belt.](#)

## PERIODIC MAINTENANCE SERVICES > Fuel Line

### INSPECTION

---

The fuel line is located mostly internally, so check pipes, areas near pipes, and engine compartment piping for rust, hose and tube damage, loose band, etc. If faulty parts are found, repair or replace them. [Ref. to FUEL INJECTION \(FUEL SYSTEMS\)\(H4DOTC\)>Fuel Delivery and Evaporation Lines>INSPECTION.](#)

## PERIODIC MAINTENANCE SERVICES > Fuel Filter

### REPLACEMENT

---

Refer to "Fuel Filter" of "FUEL INJECTION (FUEL SYSTEMS) (H4DOTC)" for fuel filter replacement procedure. [Ref. to FUEL INJECTION \(FUEL SYSTEMS\)\(H4DOTC\)>Fuel Filter.](#)

## PERIODIC MAINTENANCE SERVICES > Fuel Filter

### INSPECTION

---

Check for clogging.

## PERIODIC MAINTENANCE SERVICES > Air Cleaner Element

### REPLACEMENT

---

Refer to "Air Cleaner Element" of "INTAKE (INDUCTION) (H4DOTC)" for air cleaner element replacement procedure. [Ref. to INTAKE \(INDUCTION\)\(H4DOTC\)>Air Cleaner Element.](#)

## PERIODIC MAINTENANCE SERVICES > Cooling System

### INSPECTION

---

#### 1. RADIATOR

Check that there are no engine coolant leaks from the hose connections. Refer to "Radiator" of "COOLING (H4DOTC)" for radiator inspection procedure. [Ref. to COOLING\(H4DOTC\)>Radiator>INSPECTION.](#)

#### 2. RADIATOR CAP

Refer to "Radiator Cap" of "COOLING (H4DOTC)" for radiator cap inspection procedure. [Ref. to COOLING\(H4DOTC\)>Radiator Cap>INSPECTION.](#)

#### 3. COOLING FAN

Refer to "Radiator Fan System" of "COOLING (H4DOTC)" for cooling fan inspection procedure. [Ref. to COOLING\(H4DOTC\)>Radiator Fan System>INSPECTION.](#)

#### 4. COOLING SYSTEM

Start the engine, and then inspect that it does not overheat or it is not cooled excessively. If it overheats or it is cooled excessively, check the cooling system. [Ref. to COOLING\(H4DOTC\)>Symptoms and causes>INSPECTION.](#)

## PERIODIC MAINTENANCE SERVICES > Engine Coolant

### INSPECTION

---

Refer to "Engine Coolant" of "COOLING (H4DOTC)" for engine coolant inspection procedure. [Ref. to COOLING\(H4DOTC\)>Engine Coolant>INSPECTION.](#)

## PERIODIC MAINTENANCE SERVICES > Engine Coolant

### REPLACEMENT

---

Refer to "Engine Coolant" of "COOLING (H4DOTC)" for engine coolant replacement procedure. [Ref. to COOLING\(H4DOTC\)>Engine Coolant>REPLACEMENT.](#)

## PERIODIC MAINTENANCE SERVICES > Clutch System

### **INSPECTION**

---

Refer to "Clutch Pedal" of "CLUTCH SYSTEM" for clutch system inspection procedure. [Ref. to CLUTCH SYSTEM>Clutch Pedal>INSPECTION.](#)

## PERIODIC MAINTENANCE SERVICES > Clutch System

### **ADJUSTMENT**

---

Refer to "Clutch Pedal" of "CLUTCH SYSTEM" for clutch system adjustment procedure. [Ref. to CLUTCH SYSTEM>Clutch Pedal>ADJUSTMENT.](#)

## PERIODIC MAINTENANCE SERVICES > Transmission Gear Oil

### INSPECTION

---

Refer to "Transmission Gear Oil" of "MANUAL TRANSMISSION & DIFFERENTIAL (TY75)" for transmission gear oil inspection procedure. [Ref. to MANUAL TRANSMISSION AND DIFFERENTIAL\(TY75\)>Transmission Gear Oil>INSPECTION.](#)

## PERIODIC MAINTENANCE SERVICES > Transmission Gear Oil

### REPLACEMENT

---

Refer to "Transmission Gear Oil" of "MANUAL TRANSMISSION & DIFFERENTIAL (TY75)" for transmission gear oil replacement procedure. [Ref. to MANUAL TRANSMISSION AND DIFFERENTIAL\(TY75\)>Transmission Gear Oil>REPLACEMENT.](#)

## PERIODIC MAINTENANCE SERVICES > CVTF

### INSPECTION

---

Refer to "CVTF" of "CONTINUOUSLY VARIABLE TRANSMISSION (TR690)" for CVTF inspection procedure. [Ref. to CONTINUOUSLY VARIABLE TRANSMISSION\(TR690\)>CVTF>INSPECTION.](#)

## PERIODIC MAINTENANCE SERVICES > CVTF

### REPLACEMENT

---

Refer to "CVTF" of "CONTINUOUSLY VARIABLE TRANSMISSION (TR690)" for CVTF replacement procedure. [Ref. to CONTINUOUSLY VARIABLE TRANSMISSION\(TR690\)>CVTF>REPLACEMENT.](#)

## PERIODIC MAINTENANCE SERVICES > Front & Rear Differential Gear Oil

### INSPECTION

---

#### 1. FRONT DIFFERENTIAL (MT model)

Front differential gear oil of MT model lubricates the transmission and differential together. For inspection procedure, refer to "Transmission Gear Oil" of "MANUAL TRANSMISSION & DIFFERENTIAL". [Ref. to MANUAL TRANSMISSION AND DIFFERENTIAL\(TY75\)>Transmission Gear Oil>INSPECTION.](#)

#### 2. FRONT DIFFERENTIAL (CVT MODEL)

For inspection procedure of front differential gear oil, refer to "Differential Gear Oil" of "CONTINUOUSLY VARIABLE TRANSMISSION (TR690)". [Ref. to CONTINUOUSLY VARIABLE TRANSMISSION\(TR690\)>Differential Gear Oil>INSPECTION.](#)

#### 3. REAR DIFFERENTIAL

Refer to "Differential Gear Oil" of "DIFFERENTIALS" for rear differential gear oil inspection procedure. [Ref. to DIFFERENTIALS>Differential Gear Oil>INSPECTION.](#)

## PERIODIC MAINTENANCE SERVICES > Front & Rear Differential Gear Oil

### REPLACEMENT

---

#### 1. FRONT DIFFERENTIAL (MT model)

Front differential gear oil of MT model lubricates the transmission and differential together. For replacement procedure, refer to "Transmission Gear Oil" of "MANUAL TRANSMISSION & DIFFERENTIAL". [Ref. to MANUAL TRANSMISSION AND DIFFERENTIAL\(TY75\)>Transmission Gear Oil>REPLACEMENT.](#)

#### 2. FRONT DIFFERENTIAL (CVT MODEL)

For replacement procedure of front differential gear oil, refer to "Differential Gear Oil" of "CONTINUOUSLY VARIABLE TRANSMISSION (TR690)". [Ref. to CONTINUOUSLY VARIABLE TRANSMISSION\(TR690\)>Differential Gear Oil>REPLACEMENT.](#)

#### 3. REAR DIFFERENTIAL

Refer to "Differential Gear Oil" of "DIFFERENTIALS" for rear differential gear oil replacement procedure. [Ref. to DIFFERENTIALS>Differential Gear Oil>REPLACEMENT.](#)

## PERIODIC MAINTENANCE SERVICES > Brake Line

### INSPECTION

---

#### 1. BRAKE LINE

1. Check for scratches, swelling, corrosion, traces of brake fluid leakage on the brake hoses or pipe joints.
2. Make sure that brake pipes/hoses do not interfere with adjacent parts and there is no loose connector/clamp during driving.
3. Check any trace of brake fluid leakage, scratches, etc. on master cylinder assembly and hydraulic unit assembly VDC.

**Note:**

- **When the brake fluid level in the oil reservoir COMPL is lower than specified limit, the brake warning light on the combination meter will illuminate.**
- **Visually check the brake hose for damage. (Use a mirror where it is difficult to see)**

- (1) Brake hose front
- (2) Pipe ASSY front ABS
- (3) Clamp

- (1) Brake hose rear
- (2) Pipe center brake rear
- (3) Clamp

#### 2. SERVICE BRAKE

Refer to "Brake Pedal" of "BRAKE" for brake inspection procedure. [\\_Ref. to BRAKE>Brake Pedal>INSPECTION.](#)

### 3. BRAKE SERVO SYSTEM

**Note:**

**The vacuum booster assembly is installed on the models without EyeSight.**

1. With the engine off, depress the brake pedal several times applying the same pedal force. Check that the travel distance should not change.
2. With the brake pedal depressed, start the engine. Check that the pedal moves slightly toward the floor.
3. With the brake pedal depressed, stop the engine and keep the pedal depressed for 30 seconds. Check that the pedal height does not change.
4. A check valve is built into the vacuum hose. Disconnect the vacuum hose to inspect function of check valve.  
Check that check valve ventilates from vacuum booster assembly side to engine side. Also, check that there is no ventilation from engine side to vacuum booster assembly side.

(A) Vacuum booster ASSY

(B) Check valve

(C) Engine side

(D) Vacuum hose

5. Check the vacuum hose for cracks or other damage.

**Caution:**

**When installing the vacuum hose on the engine and vacuum booster assembly, do not use soapy water or lubricating oil on their connections.**

6. Check that the vacuum hose is securely tightened.

## PERIODIC MAINTENANCE SERVICES > Brake Fluid

### INSPECTION

---

Refer to "Brake Fluid" of "BRAKE" for brake fluid inspection procedure. [Ref. to BRAKE>Brake Fluid>INSPECTION.](#)

## PERIODIC MAINTENANCE SERVICES > Brake Fluid

### REPLACEMENT

---

Refer to "Brake Fluid" of "BRAKE" for brake fluid replacement procedure. [Ref. to BRAKE>Brake Fluid>REPLACEMENT.](#)

## PERIODIC MAINTENANCE SERVICES > Disc Brake Pad and Disc

### INSPECTION

---

Refer to "BRAKE" for brake inspection procedure.

#### **Front brake pad:**

[Ref. to BRAKE>Front Brake Pad>INSPECTION.](#)

#### **Rear brake pad:**

[Ref. to BRAKE>Rear Brake Pad>INSPECTION.](#)

#### **Front disc rotor:**

[Ref. to BRAKE>Front Disc Rotor>INSPECTION.](#)

#### **Rear disc rotor:**

[Ref. to BRAKE>Rear Disc Rotor>INSPECTION.](#)

#### **Front caliper:**

[Ref. to BRAKE>Front Disc Brake Assembly>INSPECTION.](#)

#### **Rear caliper:**

[Ref. to BRAKE>Rear Disc Brake Assembly>INSPECTION.](#)

## PERIODIC MAINTENANCE SERVICES > Parking Brake

### INSPECTION

---

- MT model  
Refer to "Parking Brake Assembly (Rear Disc Brake)" of "PARKING BRAKE" for parking brake inspection procedures. [Ref. to PARKING BRAKE>Parking Brake Assembly \(Rear Disc Brake\)>INSPECTION.](#)
- CVT model  
Refer to "Basic Diagnostic Procedure" of "BRAKE CONTROL (DIAGNOSTICS)" for parking brake inspection procedure. [Ref. to BRAKE CONTROL \(DIAGNOSTICS\)>Basic Diagnostic Procedure>PROCEDURE.](#)

## PERIODIC MAINTENANCE SERVICES > Parking Brake

### ADJUSTMENT

---

Refer to "Parking Brake Assembly (Rear Disc Brake)" of "PARKING BRAKE" for parking brake adjustment procedures. [Ref. to PARKING BRAKE>Parking Brake Assembly \(Rear Disc Brake\)>ADJUSTMENT.](#)

## INSPECTION

---

### 1. FRONT SUSPENSION BALL JOINT

- 1.** Lift up the vehicle until front wheels are off ground.
- 2.** Grasp the bottom of tire and move it in the drive shaft axial direction. If movement (B) is observed between the front brake back plate (A) and the end of arm assembly front (D), the ball joint (C) may be excessively worn.
  
- 3.** Grasp the end of arm assembly front (C) and move it up and down. If movement (A) between front axle housing (D) and arm assembly front (C) boss is observed, the ball joint (B) may be excessively worn.
  
- 4.** If the movement related to the previous two steps is observed, replace the arm assembly front. [Ref. to FRONT SUSPENSION>Front Arm.](#)
- 5.** Damage of dust boots  
Visually inspect the ball joint dust boots. Replace if the arm assembly front is damaged.

**Note:**

**When the arm assembly front is removed or replaced, check the toe-in of front wheel. If it is not within the inspection value, adjust the toe-in. [Ref. to FRONT SUSPENSION>Wheel Alignment.](#)**

(A) Dust boots

(B) Arm ASSY front

## 2. REAR SUSPENSION BALL JOINT

1. Lift up the vehicle until rear wheels are off ground.
2. Grasp the bottom of tire and move it in the drive shaft axial direction.
3. If movement is observed between the rear brake back plate (A) and end of rear lateral link assembly front (B), ball joint may be excessively worn.
  
4. Grasp the end of rear lateral link assembly front (B) and move it up and down. If movement is observed between the rear axle housing (C) and rear lateral link assembly front (B) boss, ball joint may be excessively worn.
  
5. If the movement related to the previous two steps is observed, replace the rear lateral link assembly front. [Ref. to REAR SUSPENSION>Rear Lateral Link \(front\).](#)
6. Damage of dust boots  
Visually inspect the ball joint dust boots. Replace if rear lateral link assembly front is damaged.
7. Check the arm assembly rear upper ball joint (D) and the pillow ball bushing (E) of rear axle housing in the same manner.

### **3. FRONT, REAR SUSPENSION BUSHING**

Apply pressure with tire lever etc, and inspect the bushing for excessive wear or damage. If defective, replace the bushing.

- Front suspension bushing

- Rear suspension bushing

(A) CVT model\*

(B) MT model

\*: For CVT model, rubber bushing trailing link cannot be disassembled.

#### **4. SUSPENSION HEIGHT**

Refer to "Wheel Alignment" of "FRONT SUSPENSION" for suspension height inspection procedure. [Ref. to FRONT SUSPENSION>Wheel Alignment>INSPECTION > SUSPENSION HEIGHT.](#)

#### **5. WHEEL ALIGNMENT**

Measure and adjust the front and rear wheel alignment at a time. Refer to "Wheel Alignment" of "FRONT SUSPENSION" for measurement and adjustment procedures of wheel alignment. [Ref. to FRONT SUSPENSION>Wheel Alignment>INSPECTION.](#)

#### **6. OIL LEAKAGE OF STRUT ASSEMBLY AND SHOCK ABSORBER ASSEMBLY REAR**

Visually inspect the strut assembly and shock absorber assembly rear for oil leakage. Replace the strut assembly and shock absorber assembly rear if oil leaks excessively.

#### **7. TIGHTNESS OF BOLTS AND NUTS**

Check the bolts and nuts for looseness. Retighten the bolts and nuts to specified torque if looseness is detected. Always replace non-reusable parts with new ones.

##### **Front suspension:**

[Ref. to FRONT SUSPENSION>General Description.](#)

##### **Rear suspension:**

[Ref. to REAR SUSPENSION>General Description.](#)

#### **8. DAMAGE TO SUSPENSION PARTS**

Check the following parts and the fastening portion of the vehicle body for deformation or excessive rusting which impairs the suspension. Thoroughly remove the deposits of the rubber seat LWR of strut assembly where dust or mud are likely piled up. If necessary, replace the damaged parts with new parts. If minor rust formation, pitting, etc. are noted, remove the rust and take rust prevention measure.

- Front suspension
  - Arm assembly front
  - Crossmember COMPL front
  - Strut assembly
- Rear suspension
  - Sub frame assembly rear
  - Rear lateral link assembly front
  - Rear lateral link assembly rear
  - Arm assembly rear upper
  - Trailing link assembly rear
  - Shock absorber assembly rear
- In the area where calcium chloride or other snow melting agents are sprayed to melt snow on a road in winter, check suspension parts for damage caused by rust every 12 months after 60 months have elapsed since delivery. Take rust prevention measures as required.

## PERIODIC MAINTENANCE SERVICES > Wheel Bearing

### INSPECTION

---

#### **1. FRONT HUB UNIT BEARING**

For inspection procedure of front hub unit bearing, refer to "Front Hub Unit Bearing" in "PROPELLER SHAFT / DRIVE SHAFT / AXLE". [\\_Ref. to PROPELLER SHAFT / DRIVE SHAFT / AXLE>Front Hub Unit Bearing>INSPECTION.](#)

#### **2. REAR HUB UNIT BEARING**

For inspection procedure of rear hub unit bearing, refer to "Rear Hub Unit Bearing" in "PROPELLER SHAFT / DRIVE SHAFT / AXLE". [\\_Ref. to PROPELLER SHAFT / DRIVE SHAFT / AXLE>Rear Hub Unit Bearing>INSPECTION.](#)

## INSPECTION

---

### 1. FRONT AND REAR AXLE BOOTS

Inspect the front axle boots (A) and rear axle boots (B) for deformation, damage or failure. If faulty, replace it with new part.

**Front:**

[\\_Ref. to PROPELLER SHAFT / DRIVE SHAFT / AXLE>Front Drive Shaft.](#)

**Rear:**

[\\_Ref. to PROPELLER SHAFT / DRIVE SHAFT / AXLE>Rear Drive Shaft.](#)

- Front

- Rear

### 2. PROPELLER SHAFT

Inspect the propeller shaft for damage or failure. If faulty, replace it with new part. [\\_Ref. to PROPELLER SHAFT / DRIVE SHAFT / AXLE>Propeller Shaft.](#)

## PERIODIC MAINTENANCE SERVICES > Tire Inspection and Rotation

### INSPECTION

---

Refer to "Tire and Wheel" of "WHEEL AND TIRE SYSTEM" for tire inspection and rotation procedures. [Ref. to WHEEL AND TIRE SYSTEM>Tire and Wheel>INSPECTION.](#)

## INSPECTION

---

### 1. STEERING WHEEL

1. Set the steering wheel in a straight-ahead position, and check the steering wheel spokes to make sure they are correctly set in their specified positions.
2. Lightly turn the steering wheel to the left and right to determine the point where front wheels start to move.

Measure the distance of the movement of steering wheel (periphery).

**Steering wheel free play:**

0 – 17 mm (0 – 0.67 in)

(1) [Steering wheel free play](#)

Move the steering wheel toward the shaft to check if there is play in the direction.

**Service limit:**

0.5 mm (0.02 in)

3. Check the steering wheel for looseness. If it is loose, tighten the nut to the specified torque.

**Tightening torque:**

39 N·m (4.0 kgf-m, 28.8 ft-lb)

4. Drive the vehicle and check the following items.

(1) Steering force:

The effort required for steering should be smooth and even at all points, and should not vary.

(2) Pulled to one side:

Steering wheel should not be pulled to one side while driving on a level surface.

(3) Deflection of steering wheel:

Steering wheel should not show any sign of runout.

(4) Return status:

Steering wheel should return to its original position after it has been turned and then released.

### 2. UNIVERSAL JOINT ASSEMBLY STEERING

If steering wheel play is excessive, check the universal joint assembly steering of steering shaft for looseness. If it is loose, tighten the bolt to the specified torque.

**Tightening torque:**

24 N·m (2.4 kgf-m, 17.7 ft-lb)

If the play is still excessive even after tightening the bolts to the specified torque, detach the universal joint assembly steering and then check the deflection and the swing load at the point where the joints

cross. Also, check the seal for damage or serrations for wear. [Ref. to POWER ASSISTED SYSTEM \(POWER STEERING\)>Universal Joint.](#)

### 3. STEERING GEARBOX ASSEMBLY

1. Set the steering wheel in the straight position, then rotate it 90° in both the left and right directions. While steering wheel is being rotated, check the looseness of the bolts securing the stiffener.

**Tightening torque:**

60 N·m (6.1 kgf-m, 44.3 ft-lb)

2. Check the boot steering gearbox for damage, cracks or deterioration.
3. With the vehicle stopped on a level surface, quickly turn the steering wheel to the left and right. While rotating the steering wheel, check backlash of the steering gearbox assembly. If any noise is noticed, adjust the steering gearbox assembly backlash. [Ref. to POWER ASSISTED SYSTEM \(POWER STEERING\)>Electric Power Steering Gearbox>ADJUSTMENT > GEARBOX BACKLASH ADJUSTMENT.](#)

### 4. TIE-ROD & TIE-ROD END

1. Check the tie-rod and tie-rod end for bend, cracks or other damages.

(A) Tie-rod end

(B) Tie-rod

2. Confirm that the connections of tie-rod end ball joints for play. Then check for damage on tie-rod end dust boots and free play of ball studs. If castle nut is loose, retighten it to the specified torque, then tighten further up to a maximum of 60° until the cotter pin hole is aligned.

**Tightening torque:**

27 N·m (2.8 kgf-m, 19.9 ft-lb)

3. Check the tightening of tie-rod end lock nut. If it is loose, tighten it to the specified torque.

**Tightening torque:**

85 N·m (8.7 kgf-m, 62.7 ft-lb)

## 5. BOOT STEERING GEARBOX

Inspect both sides of the boot steering gearbox as follows, and correct the defects if necessary.

1. The (A) and (B) positions of the boot steering gearbox are fitted in (C) and (D) grooves of the steering gearbox assembly and the tie-rod.
2. Clips are fitted onto the boot steering gearbox grooves at the positions (A) and (B) of the boot steering gearbox.
3. Check that there is no cracks or holes in the boot steering gearbox.

**Note:**

**Rotate (B) position of boot steering gearbox against the torsion produced by the adjustment of toe-in etc. Apply grease to the groove (D).**

**Grease:**

Silicone grease G-40M or equivalent

## 6. MOUNTING BOLT

Inspect the stiffener mounting bolts for looseness, and retighten them if necessary.

## 7. CHECK HARNESS

Check the harness of the electric power steering for cracks or damages.

Replace the harness or steering gear box assembly with a new part if necessary.

## **8. CHECK POWER STEERING CONTROL MODULE**

Check for the electric power steering diagnostic trouble codes. [Ref. to POWER STEERING \(DIAGNOSTICS\)>Basic Diagnostic Procedure>PROCEDURE.](#)

Replace the steering gear box assembly with a new part if necessary.

## PERIODIC MAINTENANCE SERVICES > A/C Filter

### REPLACEMENT

---

Refer to "A/C Filter" of "AIR CONDITIONER" for A/C filter replacement procedure. [Ref. to AIR CONDITIONER>A/C Filter>REPLACEMENT.](#)