



# POWER ASSISTED SYSTEM (POWER STEERING)

# *PS*

- 
1. General Description
  2. Relay and Fuse
  3. Power Steering System
  4. Steering Wheel
  5. Universal Joint
  6. Steering Column
  7. Electric Power Steering Gearbox
  8. Tie-rod end
  9. General Diagnostic Table

## POWER ASSISTED SYSTEM (POWER STEERING) > General Description

### CAUTION

- When performing service operation, refer to "Repair Contents" in "General Description".  [Ref. to REPAIR CONTENTS>Repair Contents.](#)
- When performing any work, always wear work clothes, a work cap and protective shoes. Additionally, wear a helmet, protective goggles, etc. if necessary.
- Refer to "CAUTION" of "General Description" in "AIRBAG SYSTEM" section.  [Ref. to AIRBAG SYSTEM>General Description>CAUTION.](#)
- Use SUBARU genuine grease, the recommended or equivalent. Do not mix grease etc. of different grades or manufacturers.
- When performing work on the sensors or modules, be careful of the following.
  - Before disconnecting electrical connectors, be sure to disconnect the ground terminal from the battery sensor.  [Ref. to REPAIR CONTENTS>NOTE > BATTERY.](#)
  - Do not apply any impact. If the parts are accidentally dropped, replace with a new part.
  - Do not expose to high-temperature and humidity.
- When replacing the parts provided with memory functions, record the memory contents before disconnecting the ground terminal from the battery sensor.
- Apply grease onto sliding or revolving surfaces before installation.
- When performing a repair, identify the cause of trouble and avoid unnecessary removal, disassembly and replacement.
- Do not secure a part in a vise directly. Place cushioning materials such as wood blocks, aluminum plates, or waste cloth between the part and the vise.
- Some vehicle components are extremely hot immediately after driving. Be wary of receiving burns from heated parts.
- Before starting works, remove dirt and corrosion around the target area.

## POWER ASSISTED SYSTEM (POWER STEERING) > General Description

### SPECIFICATION

Model		17-inch model	18-inch model
Whole system	Minimum turning radius:	5.5 (18.05)	5.6 (18.37)
	Steering angle	Inner wheel	37.2°±1.5°
		Outer wheel	32.8°±1.5°
	Lock-to-lock revolution number		2.5
Gearbox	Type	Rack & pinion type	
	Backlash	0 (automatic adjusting)	
Motor (Temperature 20°C (68°F))	Rated voltage:	12	
	Rated torque:	4.5 (0.46, 3.3)	
	Rated revolution speed:	935	

	Rated current:	A	85
	Rated output:	W	440

#### Steering wheel

Free play:	mm (in)	17 (0.67) or less
Steering wheel diameter:	mm (in)	370 (14.57)

#### Column assembly & steering

Clearance: Between steering wheel and column cover assembly	mm (in)	4 – 6 (0.16 – 0.24) or less
----------------------------------------------------------------	---------	-----------------------------

#### Steering gearbox

Sliding resistance:	N (kgf, lbf)	457 (47,103) or less Difference between right and left sliding resistance: 20% or less
Rack shaft play in radial direction: mm (in)	Right-turn steering	Both amplitudes: 0.6 (0.024) or less
	Left-turn steering	Both amplitudes: 0.6 (0.024) or less
Input shaft play: mm (in)	In radial direction	Both amplitudes: 0.6 (0.024) or less
	In axial direction	0.27 (0.0106) or less
Rotational resistance:	N (kgf, lbf)	Maximum allowable value: 30 (3, 6.7) or less Difference between right and left rotational resistance: 20% or less

#### Steering wheel effort

At standstill on paved road with engine idling:	N (kgf, lbf)	31 (3.2, 7) or less
At standstill on paved road with engine stalled:	N (kgf, lbf)	294.2 (30, 66.2) or less

## POWER ASSISTED SYSTEM (POWER STEERING) > General Description

### COMPONENT

---

# 1. STEERING WHEEL AND COLUMN

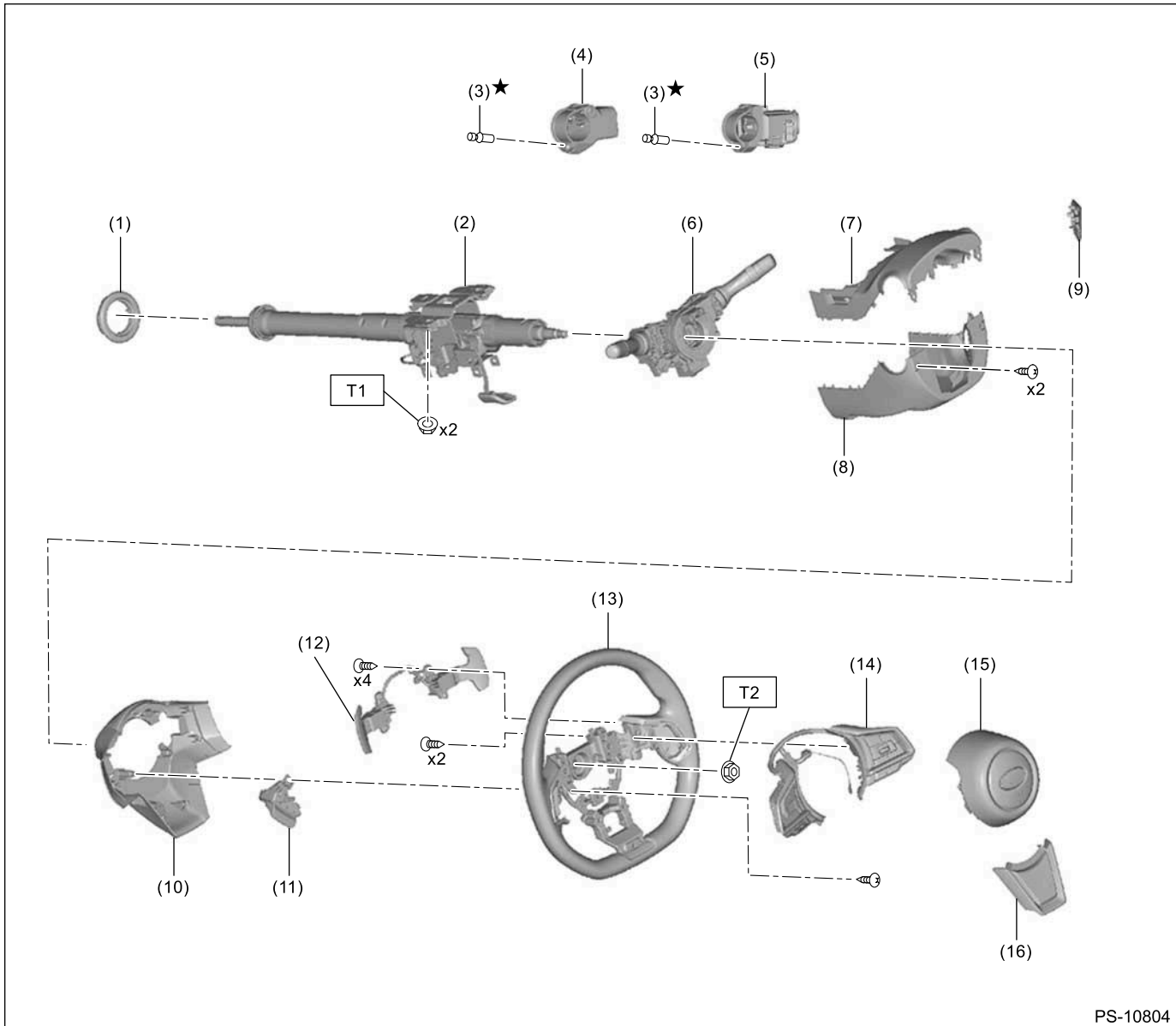

PS-10804

- |                                                                             |                                                                         |                                              |
|-----------------------------------------------------------------------------|-------------------------------------------------------------------------|----------------------------------------------|
| (1) Bushing                                                                 | (8) Column cover LWR                                                    | (15) Driver's airbag module                  |
| (2) Column ASSY steering                                                    | (9) Cap key cylinder (model with keyless access with push button start) | (16) Cover spoke                             |
| (3) Set bolt                                                                | (10) Cover steering wheel LWR                                           |                                              |
| (4) Steering lock CM (model with keyless access with push button start)     | (11) Switch ASSY steering (MID)                                         | <b>Tightening torque: N·m (kgf·m, ft·lb)</b> |
| (5) Ignition key lock (model without keyless access with push button start) | (12) Paddle shift switch ASSY (CVT model)                               | <b>T1: 20 (2.0, 14.8)</b>                    |
| (6) Switch ASSY combination (with steering roll connector)                  | (13) Steering wheel                                                     | <b>T2: 39 (4.0, 28.8)</b>                    |

(7) Column cover UPR

(14) Satellite switch

## 2. STEERING GEARBOX

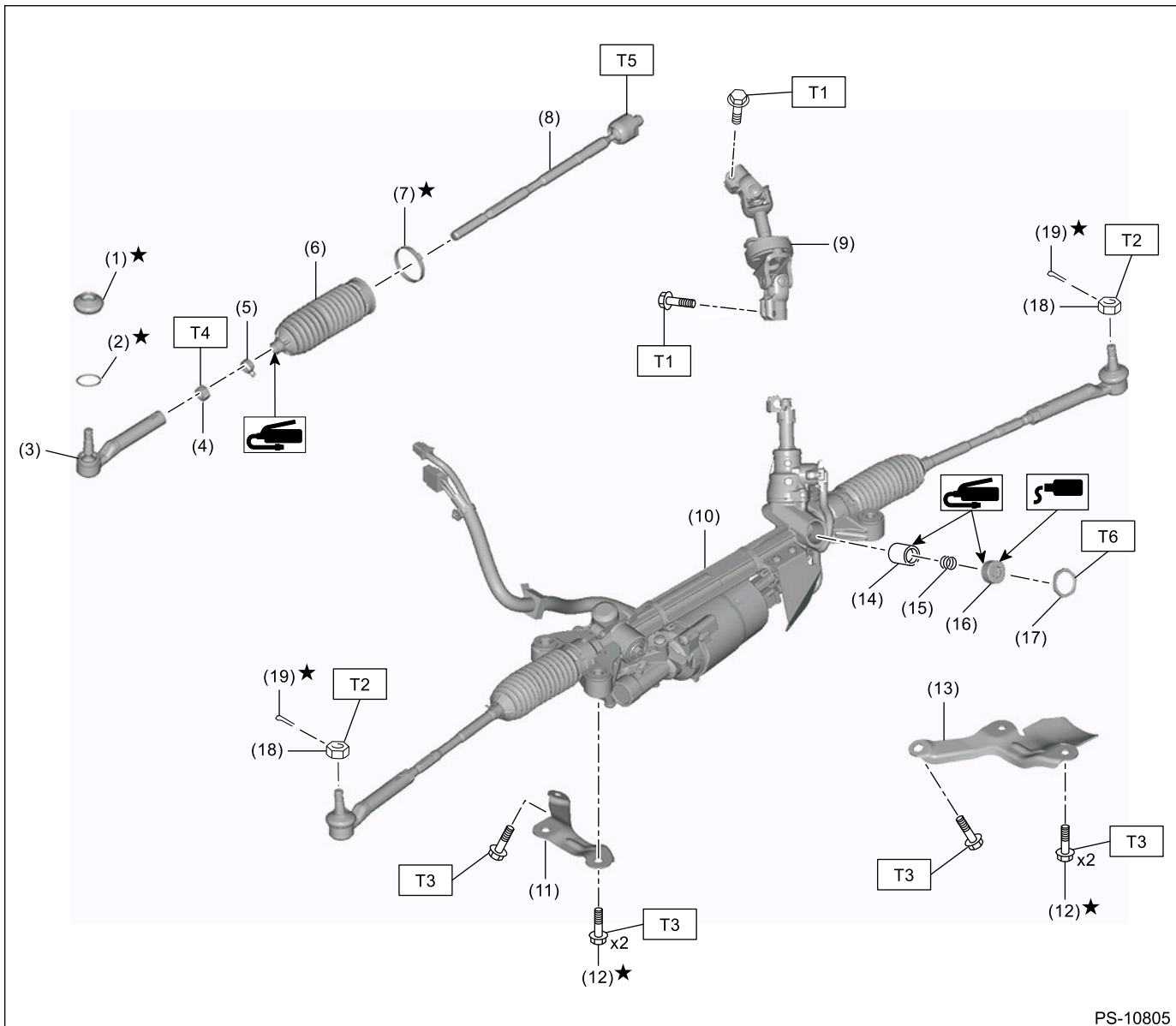

PS-10805

- |                                   |                            |
|-----------------------------------|----------------------------|
| (1) Dust boots                    | (10) Steering gearbox ASSY |
| (2) Clip boot tie-rod end         | (11) Stiffener RH          |
| (3) Tie-rod end                   | (12) Flange bolt           |
| (4) Lock nut                      | (13) Stiffener LH          |
| (5) Clip boot tie-rod             | (14) Pad pressure          |
| (6) Boot steering gearbox         | (15) Spring gearbox        |
| (7) Band boot                     | (16) Adjusting screw       |
| (8) Tie-rod                       | (17) Lock nut              |
| (9) Universal joint ASSY steering | (18) Castle nut            |

- (19) Cotter pin

**Tightening torque: N-m (kgf-m, ft-lb)**

**T1: 24 (2.4, 17.7)**

**T2: 27 (2.8, 19.9)**

**T3: 60 (6.1, 44.3)**

**T4: 85 (8.7, 62.7)**

**T5: 115 (11.7, 84.8)**

**T6:  Ref. to POWER**

**ASSISTED SYSTEM**



**(POWER**

**STEERING)>Electric Power**

POWER ASSISTED SYSTEM (POWER STEERING) > General Description

**PREPARATION TOOL**

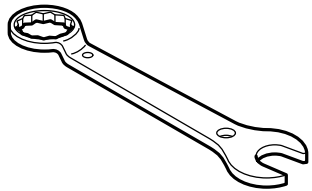
**1. SUBARU SPECIAL TOOL**

ILLUSTRATION	TOOL NUMBER	DESCRIPTION	REMARKS
 <p>ST34099PA100</p>	34099PA100	SPANNER	Used for measuring the rotational resistance of steering gearbox assembly.
 <p>STSSM4</p>	—	SUBARU SELECT MONITOR 4	Used for setting of each function and troubleshooting for electrical system. <b>Note:</b> <ul style="list-style-type: none"> <li>• For detailed operation procedures, refer to “Help” of application.</li> <li>• Used together with interface for Subaru Select Monitor (such as DST-i and DST-010).</li> </ul>

**2. OTHER**

	REMARKS
Circuit tester	Used for measuring resistance, voltage and current.
Steering wheel puller	Used for removing the steering wheel.
Ball joint puller	Used for disconnecting tie-rod end.
Boot clamp pliers	Used for tightening the boot band of the steering gearbox.
Dial gauge	Used for measuring the runout of steering gearbox assembly.
Magnet stand	Used for measuring the runout of steering gearbox assembly.
C-clamp	Used when inspecting steering gearbox assembly.
Monkey wrench	Used when adjusting steering gearbox assembly. (Tool compatible with 38 mm (1.5 in) width across flats)
12.7 mm sq (0.5 in sq) socket	Used when adjusting steering gearbox assembly. (Drain plug socket, etc.)

## POWER ASSISTED SYSTEM (POWER STEERING) > Relay and Fuse

### LOCATION

For the location, refer to "FUSE AND RELAY" in the wiring diagram.  [Ref. to WIRING SYSTEM>Fuse And Relay>LOCATION.](#)

#### Note:

For details of relay and fuse, refer to "DC POWER SUPPLY CIRCUIT".  [Ref. to WIRING SYSTEM>Power Supply Circuit>WIRING DIAGRAM.](#)

## POWER ASSISTED SYSTEM (POWER STEERING) > Relay and Fuse

### INSPECTION

#### 1. CHECK FUSE

1. Remove the fuse and inspect visually.
2. If the fuse is blown out, replace the fuse.

#### Note:

If the fuse is blown again, check the system wiring harness.

#### 2. CHECK RELAY

1. Check the resistance between relay terminals.

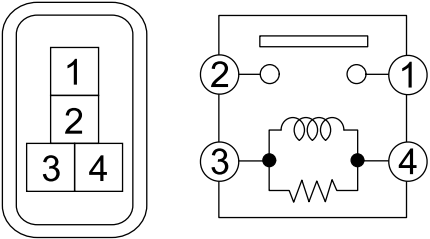
Terminal No.	Inspection conditions	Standard	Circuit
1 – 2	Always	1 M $\Omega$ or more	 LI-01273
1 – 2	Apply battery voltage between terminals 4 and 3.	Less than 1 $\Omega$	

2. Replace the relay if the inspection result is not within the standard value.

## POWER ASSISTED SYSTEM (POWER STEERING) > Power Steering System

### WIRING DIAGRAM

---

For the wiring diagram, refer to "Electric Power Steering System" in the wiring diagram.  [Ref. to WIRING SYSTEM>Electric Power Steering System>WIRING DIAGRAM.](#)

## POWER ASSISTED SYSTEM (POWER STEERING) > Power Steering System

### INSPECTION

---

#### 1. BASIC INSPECTION

For inspection, refer to "Basic Diagnostic Procedure" of "POWER STEERING (DIAGNOSTICS)" section.  [Ref. to POWER STEERING \(DIAGNOSTICS\)>Basic Diagnostic Procedure.](#)

#### 2. SYSTEM BLOCK DIAGRAM

For system block diagram, refer to "System Block Diagram" in "POWER STEERING (DIAGNOSTICS)".  [Ref. to POWER STEERING \(DIAGNOSTICS\)>General Description>SYSTEM BLOCK DIAGRAM.](#)

#### 3. MODULE I/O SIGNAL





For the specification (electrical component), refer to "Control Module I/O Signal" of "POWER STEERING (DIAGNOSTICS)" section.  [Ref. to POWER STEERING \(DIAGNOSTICS\)>Control Module I/O Signal>ELECTRICAL SPECIFICATION.](#)

## POWER ASSISTED SYSTEM (POWER STEERING) > Power Steering System

### NOTE

---

For operation procedures of components of the power steering system, refer to the following sections.



- Steering wheel:  [Ref. to POWER ASSISTED SYSTEM \(POWER STEERING\)>Steering Wheel.](#)
- Universal joint assembly:  [Ref. to POWER ASSISTED SYSTEM \(POWER STEERING\)>Universal Joint.](#)
- Steering column:  [Ref. to POWER ASSISTED SYSTEM \(POWER STEERING\)>Steering Column.](#)
- Electric power steering gearbox:  [Ref. to POWER ASSISTED SYSTEM \(POWER STEERING\)>Electric Power Steering Gearbox.](#)

## POWER ASSISTED SYSTEM (POWER STEERING) > Steering Wheel

### REMOVAL

#### Caution:

Before handling the airbag system components, always refer to "CAUTION" of "General Description" in "AIRBAG SYSTEM".  [Ref. to AIRBAG SYSTEM>General Description>CAUTION.](#)

1. Set the steering wheel to the straight-ahead position.
2. Disconnect the ground terminal from the battery sensor, and wait for at least 60 seconds before starting work.  [Ref. to REPAIR CONTENTS>NOTE > BATTERY.](#)
3. Remove the driver's airbag module.  [Ref. to AIRBAG SYSTEM>Driver's Airbag Module>REMOVAL.](#)
4. Remove the steering wheel assembly.

#### Caution:

- Always use the steering wheel puller for removal to avoid deforming the steering wheel.
- If the steering wheel has been removed, make sure that the steering roll connector is not turned from the original position.

- (1) Disconnect the connector and remove the nut.
- (2) Put an alignment mark (a) using a ruler as shown in the figure.

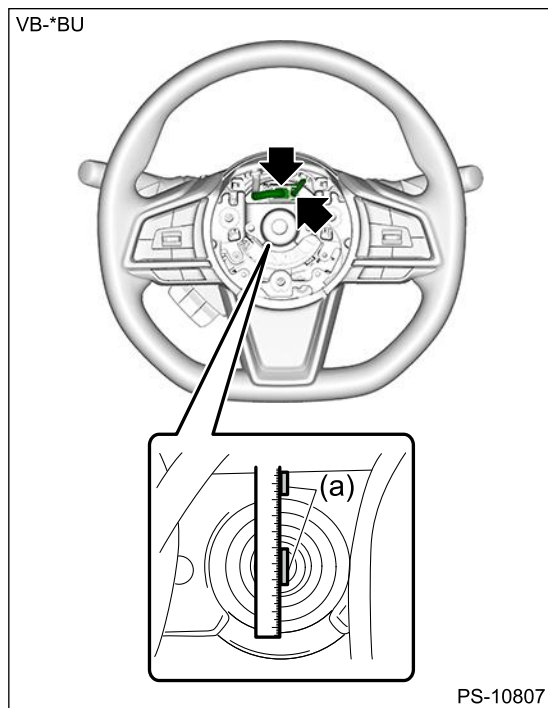





- (3) Remove the steering wheel assembly using a steering wheel puller.

## POWER ASSISTED SYSTEM (POWER STEERING) > Steering Wheel

### INSTALLATION

**Caution:**

- Before handling the airbag system components, refer to "CAUTION" of "General Description" in "AIRBAG SYSTEM".  [Ref. to AIRBAG SYSTEM>General Description>CAUTION.](#)
- If the steering wheel has been removed, make sure that the steering roll connector is not turned from the original position.

1. Align the center position of the steering roll connector.  [Ref. to AIRBAG SYSTEM>Roll Connector>ADJUSTMENT.](#)
2. Install the steering wheel assembly, and connect the connector.  
**Tightening torque:**  
39 N·m (4.0 kgf-m, 28.8 ft-lb)  
**Clearance:**  
Between column cover assembly and steering wheel: 4 — 6 mm (0.16 — 0.24 in)
3. Install the driver's airbag module.  [Ref. to AIRBAG SYSTEM>Driver's Airbag Module>INSTALLATION.](#)
4. Connect the ground terminal to battery sensor.  [Ref. to REPAIR CONTENTS>NOTE > BATTERY.](#)
5. Perform "VDC sensor midpoint setting mode".  [Ref. to VEHICLE DYNAMICS CONTROL \(VDC\)>VDC Control Module and Hydraulic Control Unit \(VDCCM&H/U\)>ADJUSTMENT > VDC SENSOR MIDPOINT SETTING MODE.](#)

**POWER ASSISTED SYSTEM (POWER STEERING) > Steering Wheel****DISASSEMBLY****Note:**

The illustration shows the CVT model.

1. Release the claws, and then remove the cover spoke.

**Caution:**

Be careful not to damage the claws and the cover spoke insertion hole during work.



2. Remove the cover steering wheel LWR.  
(1) Remove the screws on the back of the steering wheel.

VB-\*BU

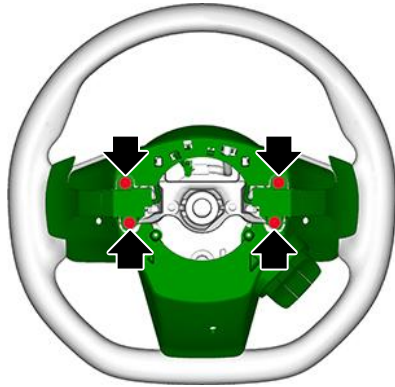

PS-10809

(2) Disconnect the connector.

(3) Release the screws, claws and harness clips, and detach the cover steering wheel LWR.

VB-\*BU



PS-10810

**3.** Remove the paddle shift switch assembly.

VB-\*BU



PS-10811

**4.** Release the claws, and then remove the switch assembly steering (MID) switch.

VB-\*BU



PS-10812

5. Remove the screws and release the claws, then remove the satellite switch.

VB-\*BU

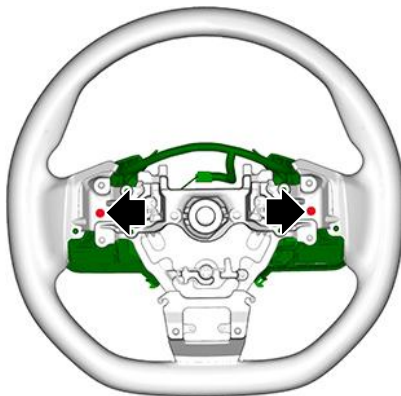

PS-10813

## POWER ASSISTED SYSTEM (POWER STEERING) > Steering Wheel

### ASSEMBLY

#### Caution:

**Securely install the switch and the cover steering wheel LWR. Improper insertion of the pins or claws of the switch and the cover steering wheel LWR may cause improper installation.**

1. Install the satellite switch.
2. Install the switch assembly steering (MID).
3. Install the paddle shift switch assembly.
4. Install the cover steering wheel LWR, and connect the connector.
5. Install the cover spoke.

**INSPECTION**

**1. PADDLE SHIFT SWITCH**

1. Measure the resistance between connector terminals.

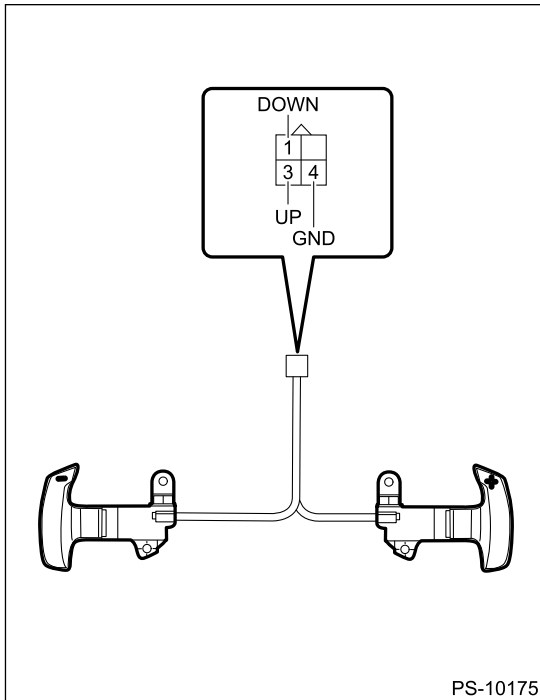



Terminal No.	Inspection conditions	Standard
3 – 4	Operate the + side of paddle shift and hold it.	Less than 10 Ω
1 – 4	Operate the – side of paddle shift and hold it.	Less than 10 Ω
1 – 4 3 – 4	Do not operate the paddle shift.	1 MΩ or more

2. Replace the paddle shift switch assembly if the inspection result is not within the standard value.

**2. SATELLITE SWITCH ASSEMBLY**

For the satellite switch assembly inspection, refer to the following sections.

- Audio (navigation) switch:  [Ref. to ENTERTAINMENT & MONITORING>Switches and Harness>INSPECTION > AUDIO STEERING SWITCH.](#)
- EyeSight steering switch:  [Ref. to EyeSight>Steering Switch>INSPECTION.](#)
- Cruise control steering switch:  [Ref. to CRUISE CONTROL SYSTEM>Steering Switch>INSPECTION.](#)

**3. MULTI INFORMATION DISPLAY SWITCH**

For the multi information display switch inspection, refer to “Multi information display switch” of “INSTRUMENTATION/DRIVER INFO” section.  [Ref. to INSTRUMENTATION/DRIVER INFO>Switches and Harness>INSPECTION > MULTI INFORMATION DISPLAY SWITCH.](#)

## POWER ASSISTED SYSTEM (POWER STEERING) > Universal Joint

### REMOVAL



1. Set the steering wheel to the straight-ahead position.
2. Adjust the tilt position of the steering column to the neutral position.

**Note:**

**Place the tilt lever to the lock position after the steering column is adjusted.**

3. Prevent the steering wheel from turning using the seat belt.

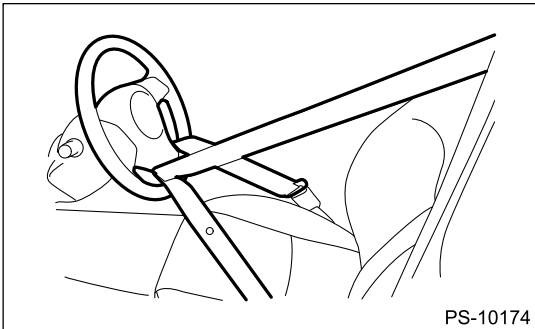

4. Remove the universal joint assembly steering.
  - (1) Place an alignment mark between the column assembly steering and universal joint assembly steering.
  - (2) Remove the bolt, and remove the universal joint assembly steering.

**Caution:**

**Do not remove the guide camera.**

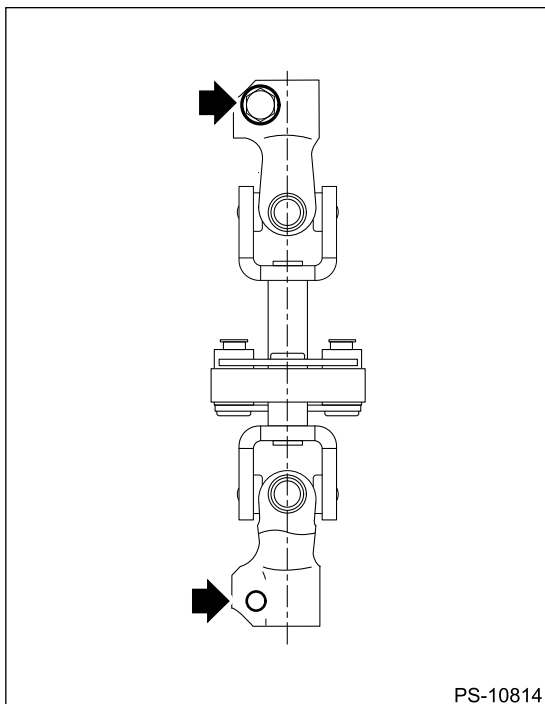

## POWER ASSISTED SYSTEM (POWER STEERING) > Universal Joint

### INSTALLATION

1. Before installation, check the universal joint assembly steering.  Ref. to [POWER ASSISTED SYSTEM \(POWER STEERING\)>Universal Joint>INSPECTION.](#)
2. Adjust the tilt position of the steering column to the neutral position.

**Note:**

**Place the tilt lever to the lock position after the steering column is adjusted.**

3. Install the universal joint assembly steering.

**Caution:**

- Be sure to align the protrusion section (a) of the column shaft side with the cutout (a) of the serration. If other cutout portions (b) are used for alignment, the bolt of the universal joint assembly steering cannot be assembled.
- Be sure to follow the tightening order and tightening torque of the universal joint assembly steering to avoid the steering effort from becoming heavy. After confirming that the steering column position is in the neutral position, tighten the universal joint assembly steering.
- When tightening the mounting bolts of the universal joint assembly steering, always tighten the gearbox side bolts first.
- Always place the tilt lever to the lock position after the steering column is adjusted.

- (1) Match the alignment marks that were placed during removal with the column shaft (d) and the cutout portion (a) at the serrations of the yoke (c).
- (2) Connect the universal joint assembly steering with the column shaft.

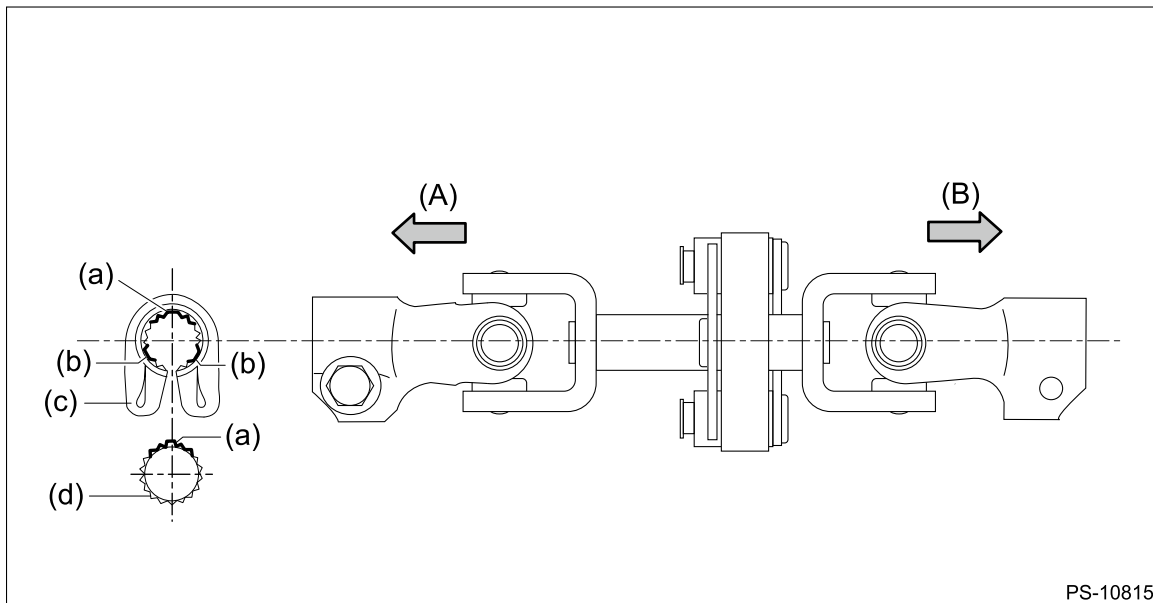

(A) Column shaft side

(B) Gearbox side

- (3) Install the universal joint assembly steering to the serrations of the gearbox assembly by matching the cutout portion of the guide (a).

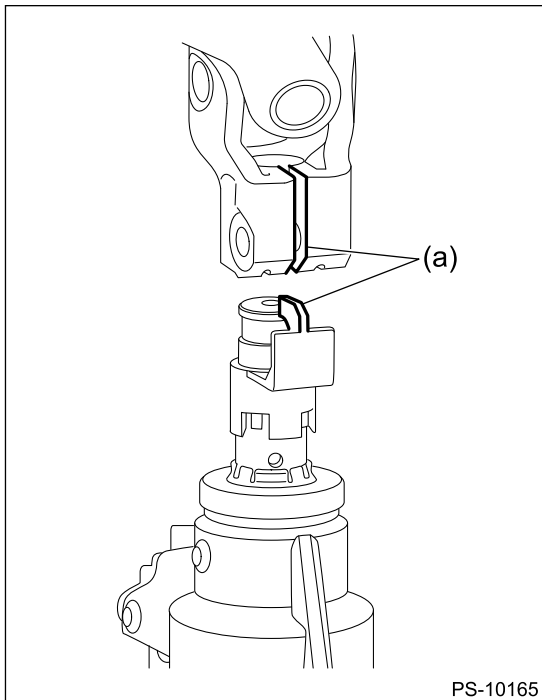

(4) Tighten the bolts on the gearbox side first, and then the column shaft side.

**Tightening torque:**

24 N·m (2.4 kgf-m, 17.7 ft-lb)

**Clearance:**

Universal joint assembly steering coupling to adjacent parts: 15 mm (0.59 in) or more

4. Unfasten the seat belt and make the steering wheel turn freely.

**POWER ASSISTED SYSTEM (POWER STEERING) > Universal Joint**

**INSPECTION**

Check for wear, damage or any other faults.

1. Check the universal joint assembly steering for excessive looseness.

**Service limit:**

Play of the universal joint assembly steering: 0 mm (0 in)

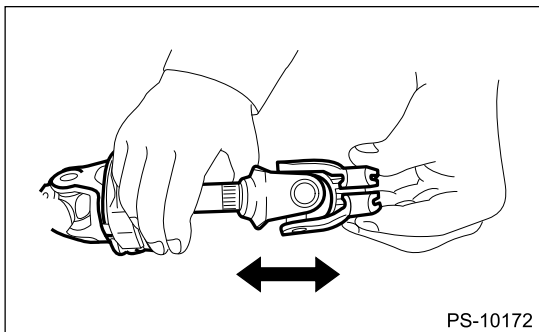

2. Measure the swing load of the universal joint assembly steering.

(1) Place the universal joint assembly steering between wooden blocks and fix it on a vise.

(2) With the yoke (a) of gearbox side facing up, measure the swing load in two directions.

**Service limit:**

Maximum load: 4.5 N (0.46 kgf, 1.01 lbf) or less

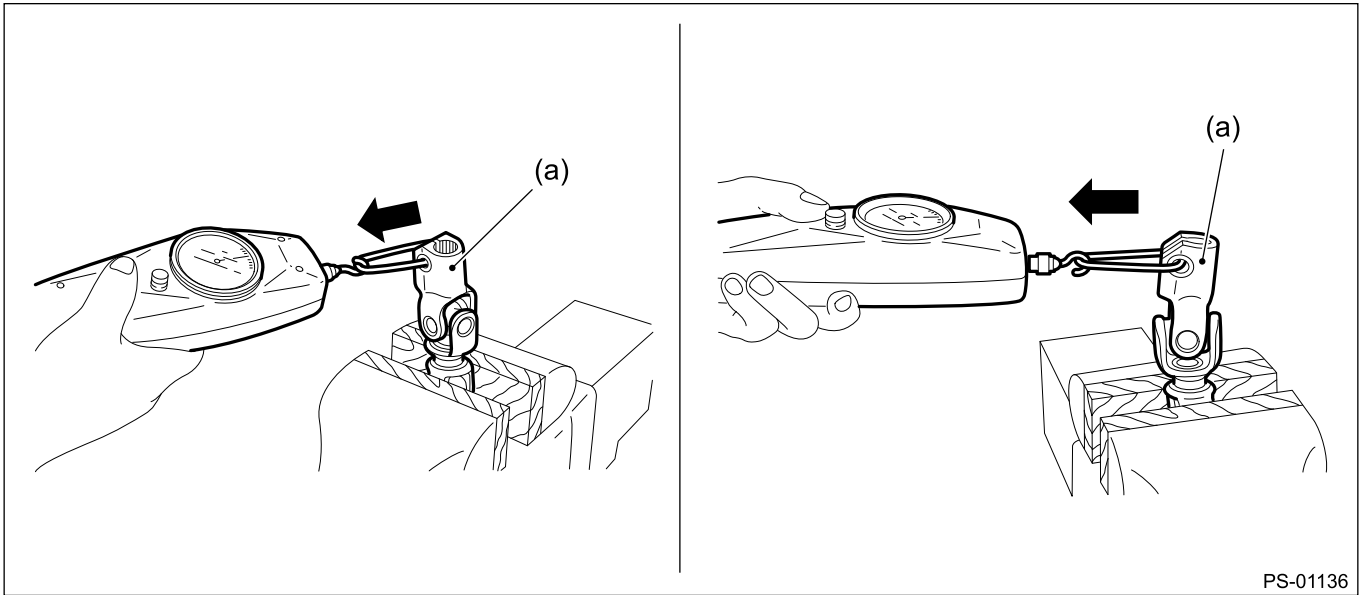

(3) With the yoke (b) of the column assembly steering side facing up, measure the swing load in two directions.

**Service limit:**

Maximum load: 5.4 N (0.55 kgf, 1.21 lbf) or less

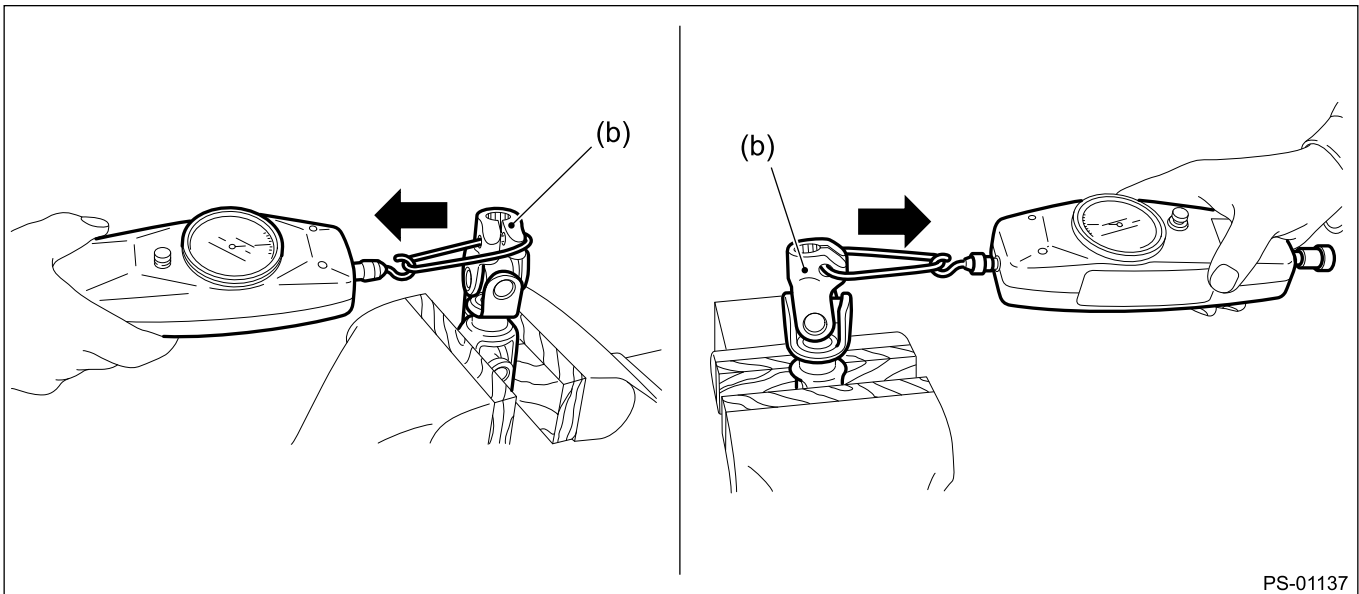

(4) Replace as necessary, if it is found defective.

## POWER ASSISTED SYSTEM (POWER STEERING) > Steering Column

### REMOVAL



#### Caution:

Before handling the airbag system components, always refer to "CAUTION" of "General Description" in "AIRBAG SYSTEM".  [Ref. to AIRBAG SYSTEM>General Description>CAUTION.](#)







#### Note:

The illustration shows the model with keyless access with push button start.

1. Adjust the tilt position of the steering column to the neutral position and the telescopic position to the longest position.

#### Note:

Place the tilt lever to the lock position after the steering column is adjusted.

2. Disconnect the ground terminal from the battery sensor, and wait for at least 60 seconds before starting work.  [Ref. to REPAIR CONTENTS>NOTE > BATTERY.](#)
3. Remove the driver's airbag module.  [Ref. to AIRBAG SYSTEM>Driver's Airbag Module>REMOVAL.](#)
4. Remove the steering wheel assembly.  [Ref. to POWER ASSISTED SYSTEM \(POWER STEERING\)>Steering Wheel>REMOVAL.](#)
5. Remove the cover LWR driver.  [Ref. to EXTERIOR/INTERIOR TRIM>Instrument Panel Lower Cover>REMOVAL.](#)
6. Remove the knee airbag module.  [Ref. to AIRBAG SYSTEM>Knee Airbag Module>REMOVAL.](#)
7. Remove the duct foot driver.  [Ref. to AIR CONDITIONER>Air Vent Duct>REMOVAL > FOOT DUCT.](#)
8. Remove the column cover assembly.
  - (1) Release the clips and claws, and remove the cover steering UPR.
  - (2) Remove the screws.

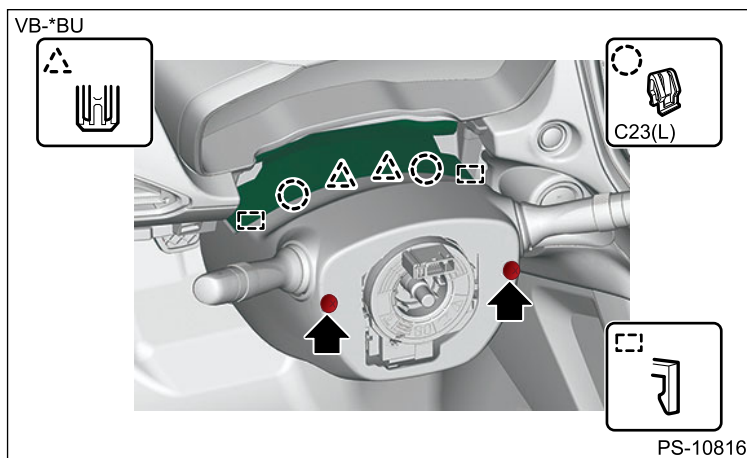

- (3) Release the claws and then remove the cap key cylinder. (Model with keyless access with push button start)
- (4) Release the claw and the positioning pin, and remove the column cover LWR.

#### Note:

Release the claws on RH side in the same procedure as on the LH side.

VB-\*BU

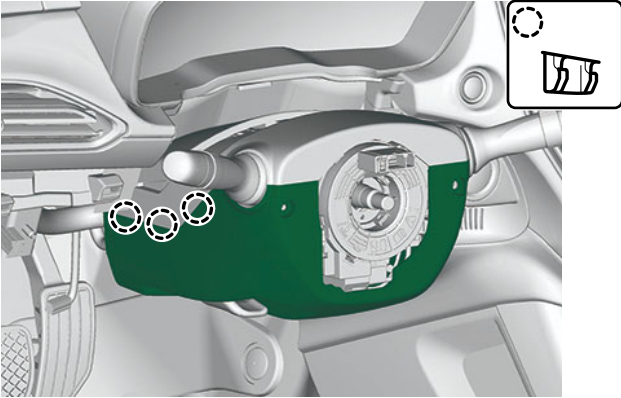

PS-10817

(5) Release the claws and remove the column cover UPR.

VB-\*BU



PS-10818

**9.** Remove the switch assembly combination.

- (1) Disconnect the connector.
- (2) Using pliers, loosen the clamp.
- (3) With the clamp loosened, release the claw using a flat tip screwdriver wrapped with protective tape, and remove the switch assembly combination.

**Caution:**

**Do not pry off forcibly. Otherwise, the claws may be damaged.**

**Note:**

**Remove the switch assembly combination together with the steering roll connector as an assembly.**

SK-\*BE

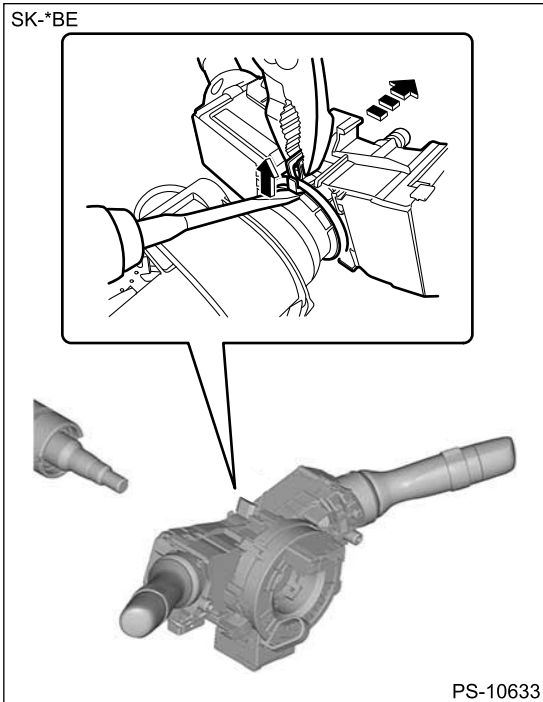

- 10.** Remove the universal joint assembly steering.  Ref. to [POWER ASSISTED SYSTEM \(POWER STEERING\)>Universal Joint>REMOVAL](#).

**Caution:**

**To prevent damage to the universal joint assembly steering and improper steering effort, make sure to remove the universal joint assembly steering.**

- 11.** Remove the column assembly steering.

**Caution:**

**Never loosen the tilt lever when the column assembly steering is not secured to the vehicle.**

- (1) Disconnect all connectors from the column assembly steering.
- (2) Remove the nut under the beam COMPL steering which secures the column assembly steering.

VB-\*BU

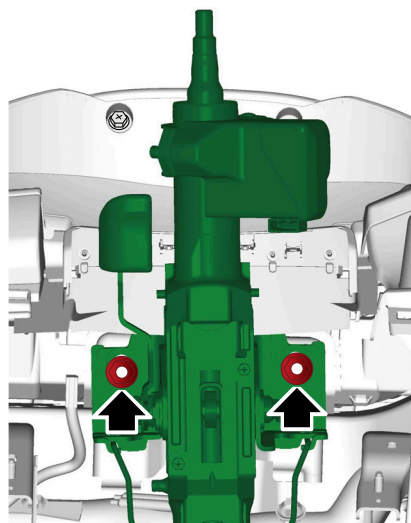

PS-10819

(3) Pull out the column assembly steering from the hole on toe board.

**12.** Remove the ignition key lock or steering lock CM.  [Ref. to SECURITY AND LOCKS>Ignition Key Lock>REPLACEMENT.](#)

## POWER ASSISTED SYSTEM (POWER STEERING) > Steering Column

### INSTALLATION

#### Caution:

**Before handling the airbag system components, always refer to "CAUTION" of "General Description" in "AIRBAG SYSTEM".**  [Ref. to AIRBAG SYSTEM>General Description>CAUTION.](#)

**1.** Install the column assembly steering.

(1) Install the bushing (a) to the toe board from the passenger compartment side.



(2) Insert the end of the column assembly steering into the toe board bushing.

(3) Tighten the column assembly steering installation nut located under the beam steering COMPL with the tilt lever fixed.

#### Tightening torque:

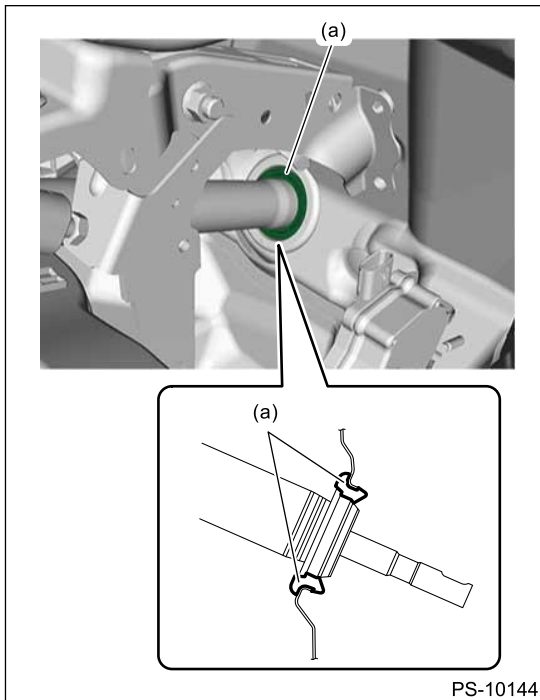







20 N·m (2 kgf-m, 14.8 ft-lb)



2. Install the ignition key lock or steering lock CM.  [Ref. to SECURITY AND LOCKS>Ignition Key Lock>REPLACEMENT.](#)
3. Install the universal joint assembly steering.  [Ref. to POWER ASSISTED SYSTEM \(POWER STEERING\)>Universal Joint>INSTALLATION.](#)

**Caution:**

- **Always install the universal joint assembly steering after installing the steering column to avoid damage to the universal joint assembly steering.**
- **Be sure to follow the tightening order and tightening torque of the universal joint assembly steering to avoid the steering effort from becoming heavy. After confirming that the steering column position is in the neutral position, tighten the universal joint assembly steering.**

4. Install the switch assembly combination.  [Ref. to LIGHTING SYSTEM>Combination Switch \(Light\)>INSTALLATION.](#)
5. Align the center position of the steering roll connector.  [Ref. to AIRBAG SYSTEM>Roll Connector>ADJUSTMENT.](#)
6. Connect all the connectors under the instrument panel.
7. Install the column cover assembly.
8. Install the duct foot driver.  [Ref. to AIR CONDITIONER>Air Vent Duct>INSTALLATION > FOOT DUCT.](#)
9. Install the knee airbag module.  [Ref. to AIRBAG SYSTEM>Knee Airbag Module>INSTALLATION.](#)
10. Install the cover LWR driver.  [Ref. to EXTERIOR/INTERIOR TRIM>Instrument Panel Lower Cover>INSTALLATION.](#)
11. Install the steering wheel assembly.  [Ref. to POWER ASSISTED SYSTEM \(POWER STEERING\)>Steering Wheel>INSTALLATION.](#)
12. Install the driver's airbag module.  [Ref. to AIRBAG SYSTEM>Driver's Airbag Module>INSTALLATION.](#)
13. Connect the ground terminal to battery sensor.  [Ref. to REPAIR CONTENTS>NOTE > BATTERY.](#)

**Note:**

**Place the tilt lever to the lock position after the steering column is adjusted.**

- 14.** Perform "VDC sensor midpoint setting mode".  Ref. to [VEHICLE DYNAMICS CONTROL \(VDC\)>VDC Control Module and Hydraulic Control Unit \(VDCCM&H/U\)>ADJUSTMENT > VDC SENSOR MIDPOINT SETTING MODE.](#)

**POWER ASSISTED SYSTEM (POWER STEERING) > Steering Column**

**INSPECTION**

**1. UNIT INSPECTION**

- 1.** Check the aluminum capsules (a) for looseness.

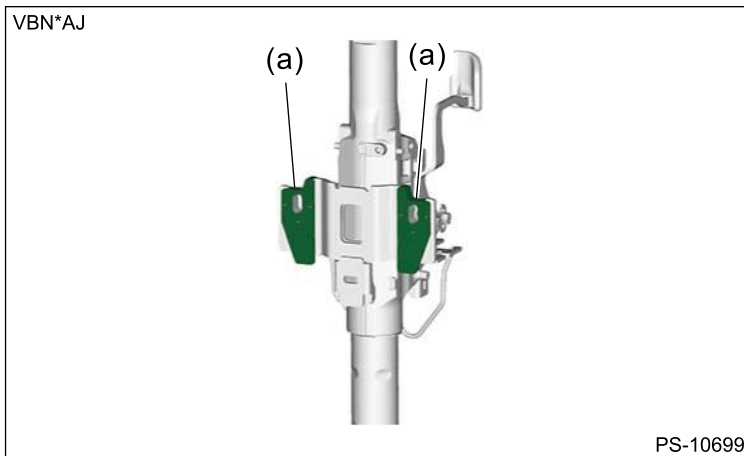

- 2.** Check the following items, and if there is anything out of standard value, it is considered to be damaged. If so, replace it with a new part.

- Measure the overall length of the column assembly steering jacket.

**Standard: Overall length L of the jacket**

**Tilt and telescopic column (measure while minimized)**

234 mm (9.21 in) or more

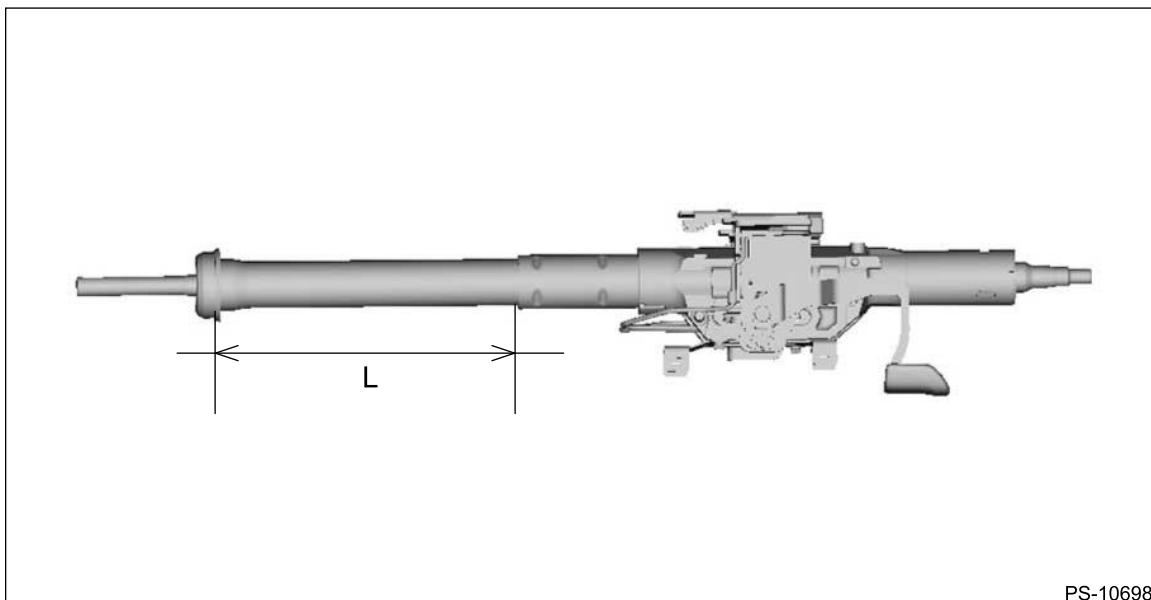

- Check the steering wheel deflection in axial and vertical directions.

**Specification:**

**Axial deflection A (deflection of steering wheel)**

Less than 6 mm (0.24 in)

**Vertical deflection L (runout of steering wheel)**

Less than 17 mm (0.67 in)

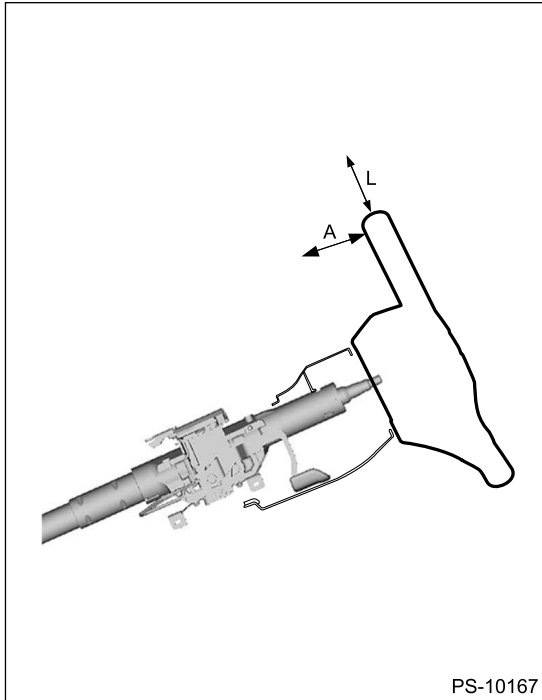

PS-10167

## 2. INSPECTION OF AIRBAG SYSTEM

For the airbag inspection procedure, refer to "Driver's Airbag Module" in the "AIRBAG SYSTEM" section.

 [Ref. to AIRBAG SYSTEM>Driver's Airbag Module>INSTALLATION.](#)

## POWER ASSISTED SYSTEM (POWER STEERING) > Electric Power Steering Gearbox

### REMOVAL







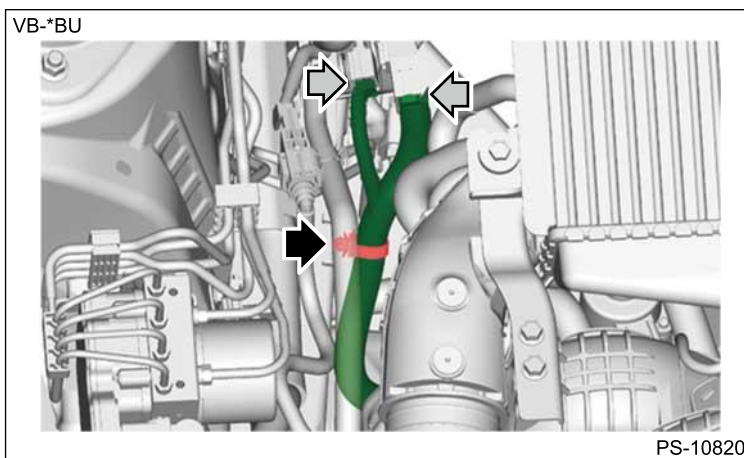

#### Caution:

- **The power steering control module continues to operate after the engine stops and calculates the temperature in the control module. Therefore, before starting service of the power steering system which requires disconnection of the connector, stop the engine and allow approx. 30 minutes until the control module becomes cold.**
- **Be careful not to let any foreign matter (dust, water, oil, etc.) enter into the power steering control module connector when removing or installing. If a foreign matter enters, completely remove it.**

1. Remove the ground terminal from battery sensor.  [Ref. to REPAIR CONTENTS>NOTE > BATTERY.](#)
2. Disconnect the power steering harness connector and remove the harness clamp.



3. Remove the front wheels.  [Ref. to WHEEL AND TIRE SYSTEM>Tire and Wheel>REMOVAL.](#)
4. Remove the under guard front.  [Ref. to EXTERIOR/INTERIOR TRIM>Front Under Cover>REMOVAL.](#)
5. Remove the crossmember support rear and the crossmember support front.  [Ref. to FRONT SUSPENSION>Crossmember Support>REMOVAL.](#)
6. Remove the center exhaust pipe (rear).  [Ref. to EXHAUST\(H4DOTC\)>Center Exhaust Pipe>REMOVAL > CENTER EXHAUST PIPE \(REAR\).](#)
7. Remove the stabilizer front.  [Ref. to FRONT SUSPENSION>Stabilizer>REMOVAL > STABILIZER.](#)
8. Disconnect the tie-rod end.  [Ref. to POWER ASSISTED SYSTEM \(POWER STEERING\)>Tie-rod end>REMOVAL.](#)
9. Remove the universal joint assembly steering.  [Ref. to POWER ASSISTED SYSTEM \(POWER STEERING\)>Universal Joint>REMOVAL.](#)
10. Remove the steering gearbox assembly.
  - (1) Remove the harness clamp of the power steering harness.

VB-\*BU

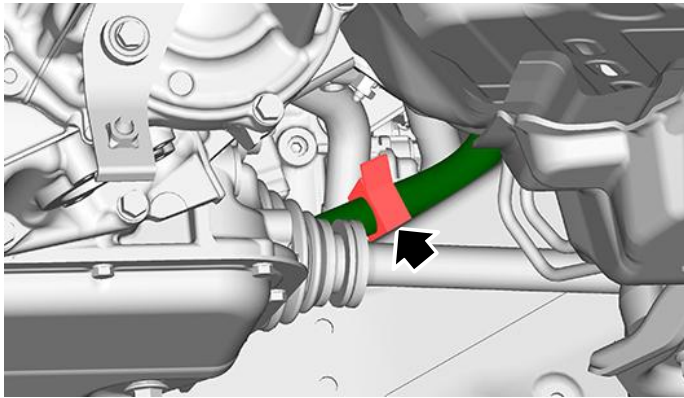

PS-10821

- (2) Support the steering gearbox assembly from the bottom side using a transmission jack.
- (3) Remove the bolts, then remove the stiffener.
- (4) Lower the transmission jack slowly, and lower the steering gearbox assembly.

**Caution:**

**When lowering the transmission jack, make sure that the tie-rod end and the drive shaft boot do not interfere. The drive shaft boot may be damaged.**

VB-\*BU

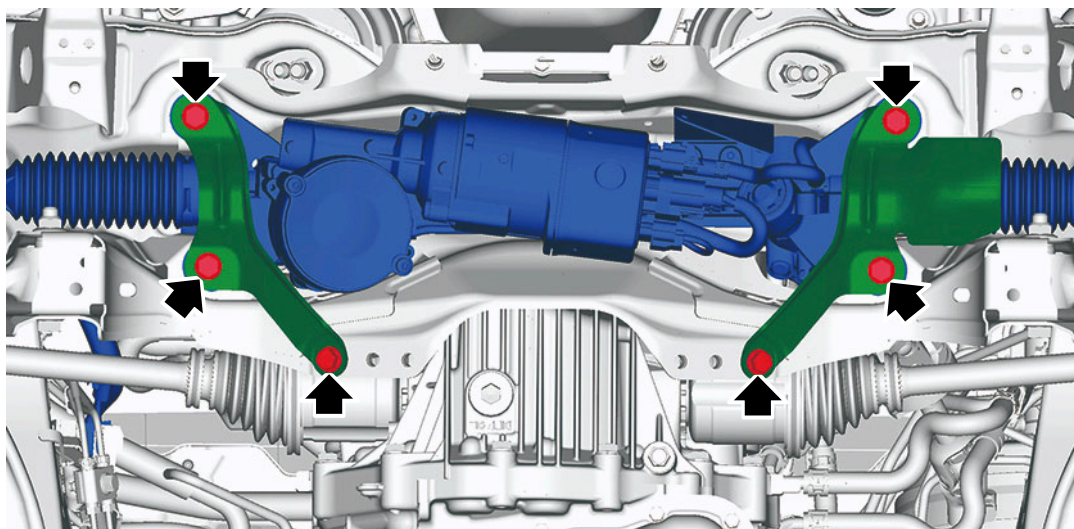

PS-10822

## POWER ASSISTED SYSTEM (POWER STEERING) > Electric Power Steering Gearbox INSTALLATION









**Caution:**

- **When raising the transmission jack, make sure that the tie-rod end and the drive shaft boot do not interfere. The drive shaft boot may be damaged.**
- **For parts which are not reusable, always use new parts.**

- 1.** Install the steering gearbox assembly and stiffener.

**Tightening torque:**

Refer to "COMPONENT" of "General Description" for the tightening torque.  Ref. to [POWER ASSISTED SYSTEM \(POWER STEERING\)>General Description>COMPONENT > STEERING GEARBOX.](#)

2. Install the universal joint assembly steering.  Ref. to [POWER ASSISTED SYSTEM \(POWER STEERING\)>Universal Joint>INSTALLATION.](#)
3. Connect the tie-rod ends.  Ref. to [POWER ASSISTED SYSTEM \(POWER STEERING\)>Tie-rod end>INSTALLATION.](#)
4. Install the stabilizer front.  Ref. to [FRONT SUSPENSION>Stabilizer>INSTALLATION > STABILIZER.](#)
5. Install the center exhaust pipe (rear).  Ref. to [EXHAUST\(H4DOTC\)>Center Exhaust Pipe>INSTALLATION > CENTER EXHAUST PIPE \(REAR\).](#)
6. Install the crossmember support front and the crossmember support rear.  Ref. to [FRONT SUSPENSION>Crossmember Support>INSTALLATION.](#)
7. Install the under guard front.  Ref. to [EXTERIOR/INTERIOR TRIM>Front Under Cover>INSTALLATION.](#)
8. Install the front wheels.  Ref. to [WHEEL AND TIRE SYSTEM>Tire and Wheel>INSTALLATION.](#)
9. Install the power steering harness connector and harness clamp.
10. Connect the ground terminal to battery sensor.  Ref. to [REPAIR CONTENTS>NOTE > BATTERY.](#)
11. After adjusting toe-in and steering angle, tighten the lock nut on tie-rod end.

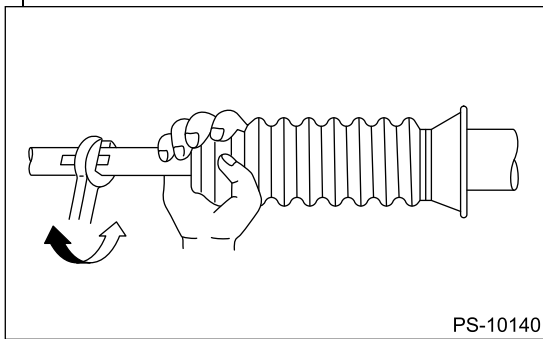

**Note:**

**When adjusting toe-in, hold the boot steering gearbox as shown to prevent it from being rotated or twisted. If it becomes twisted, straighten it.**



**Tightening torque:**

85 N·m (8.7 kgf-m, 62.7 ft-lb)

12. Perform "VDC sensor midpoint setting mode".  Ref. to [VEHICLE DYNAMICS CONTROL \(VDC\)>VDC Control Module and Hydraulic Control Unit \(VDCCM&H/U\)>ADJUSTMENT > VDC SENSOR MIDPOINT SETTING MODE.](#)
13. Perform the lane keep assist learning value clear.  Ref. to [EyeSight \(DIAGNOSTICS\)>Work Support.](#)

## POWER ASSISTED SYSTEM (POWER STEERING) > Electric Power Steering Gearbox DISASSEMBLY



**Note:**

**When fixing the steering gearbox assembly in a vise, apply a wooden piece on the flange portion.**

1. Remove the tie-rod end (a) and lock nut (b) from the steering gearbox assembly.
2. Remove the clip boot tie-rod (c) located outside the boot steering gearbox using the pliers, and then slide the boot steering gearbox to the tie-rod end side.

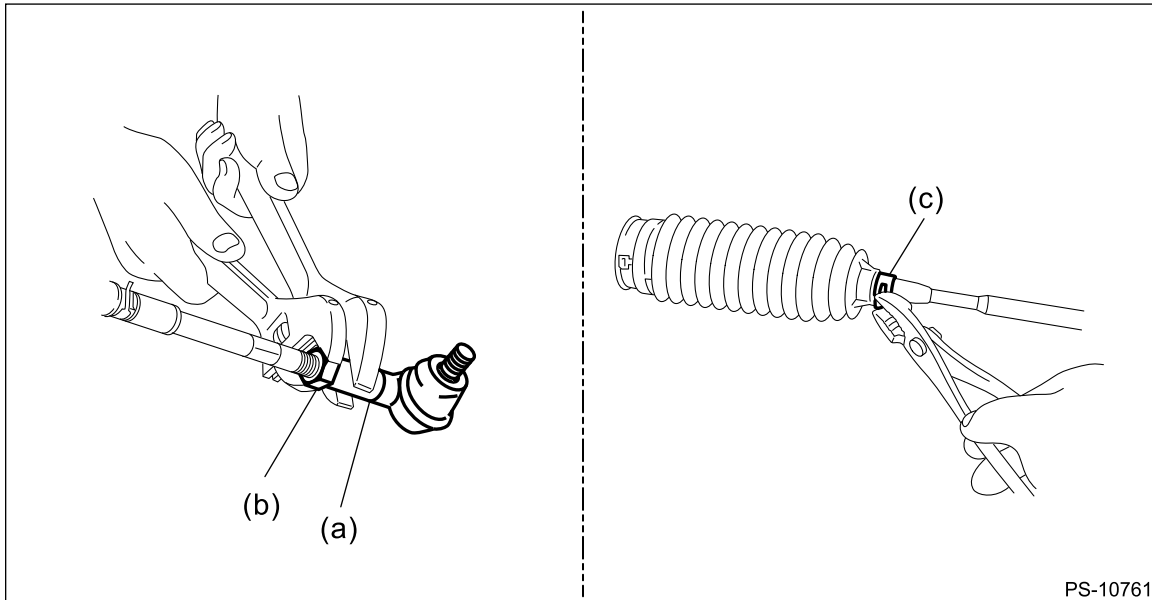

3. Remove the tie-rod (b) from the gearbox assembly.  
(1) Using a flat tip screwdriver, remove the band boot (a) from the boot steering gearbox.

**Note:**

**Replace the boot steering gearbox or the band boot (a) if there is damage, cracks or deterioration.**

- (2) Remove the tie-rod (b).

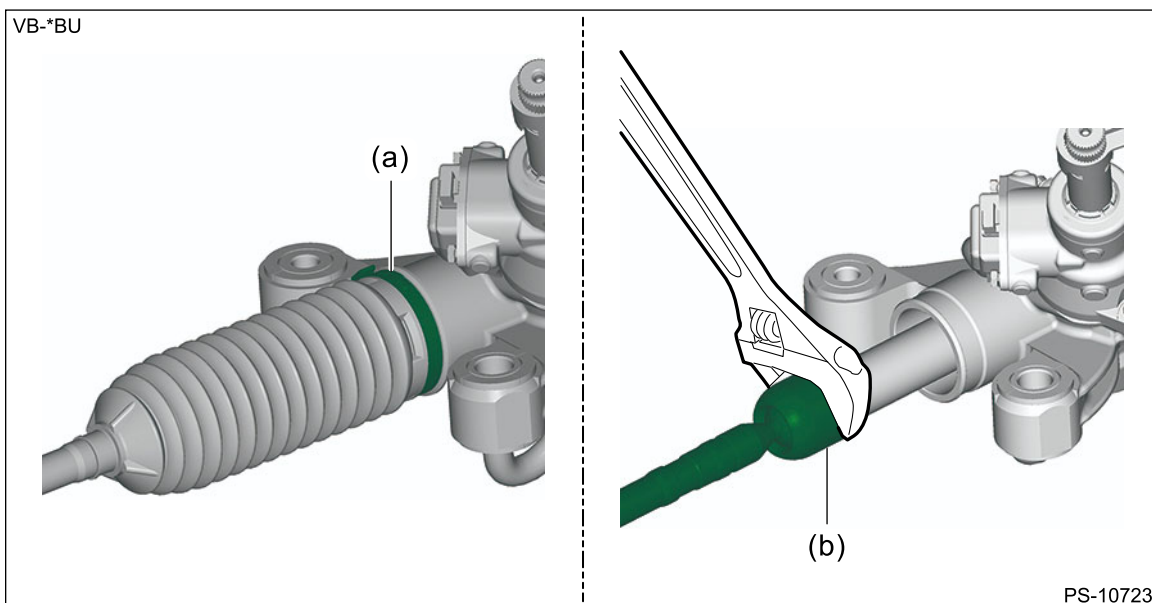

## POWER ASSISTED SYSTEM (POWER STEERING) > Electric Power Steering Gearbox

### ASSEMBLY

---

1. Install the tie-rod into rack.

**Note:**

**Check the mating face of rack and tie-rod for foreign matter such as dust etc.**

**Tightening torque:**

115 N·m (11.7 kgf-m, 84.8 ft-lb)

2. Apply a coat of grease to the tie-rod groove, and then install the boot steering gearbox to the housing.

**Caution:**

**Assemble the small end of the boot steering gearbox in the tie-rod groove first, and then assemble the large end of the boot steering gearbox in the housing.**

**Note:**

**Make sure that the boot steering gearbox is installed without unusual inflation or deflation.**

**Preparation items:**

Grease: Silicone grease G-40M or equivalent

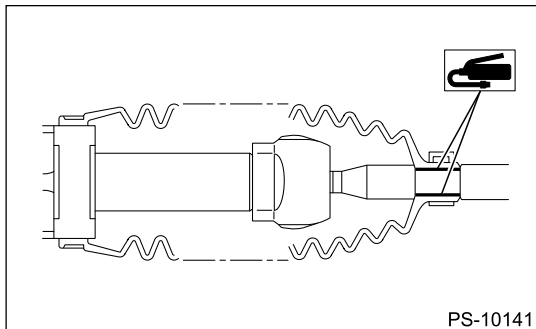

3. Using the boot clamp pliers, crimp a new band boot (a) so that the clearance (b) of the boot crimp portion becomes 2 mm (0.08 in) or less.

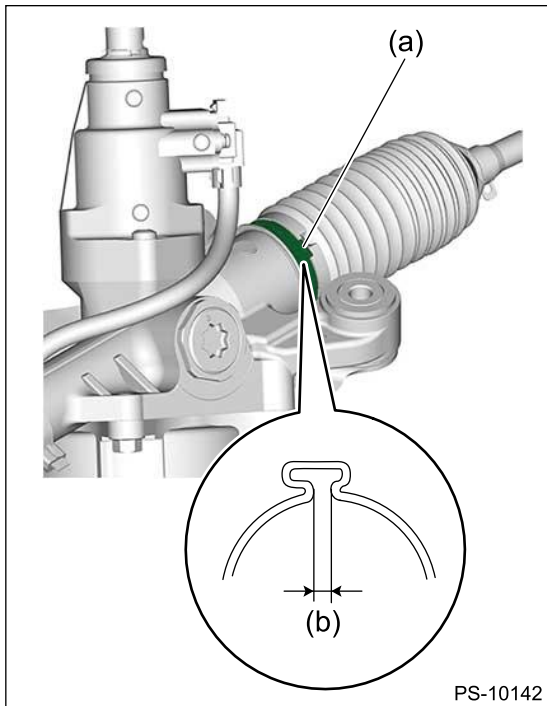

4. Fix the end of the boot steering gearbox with clip boot tie-rod (a).
5. After installation, check that the end of the boot steering gearbox is installed to the groove (b) of the tie-rod.

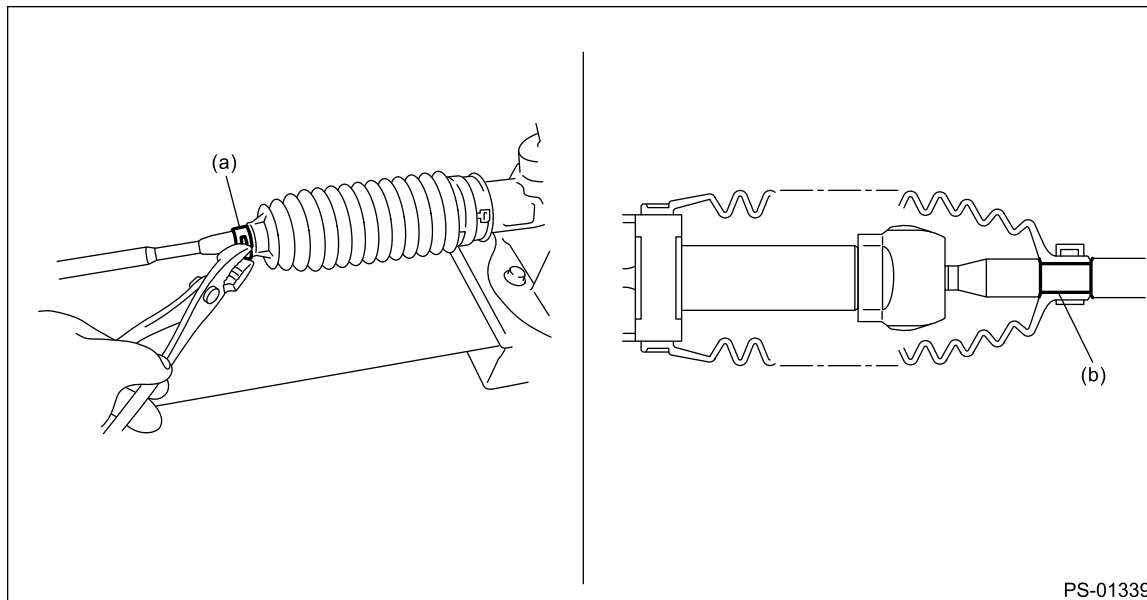

6. If the tie-rod end has been removed, screw in lock nut and tie-rod end to the threaded portion of tie-rod, and tighten the lock nut temporarily in a position as shown in the figure.

**Installed tie-rod length:**

L: 21 mm (0.83 in)

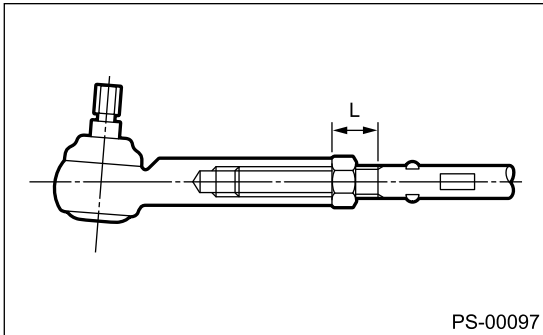

**7.** Inspect the steering gearbox assembly as follows:

1. "A" Holding the tie-rod end, repeat lock to lock several times as quickly as possible.
2. "B" Holding the tie-rod end, turn it slowly at a radius several times as large as possible.
3. Finally, make sure that the boot steering gearbox is installed in the specified position without inflating.

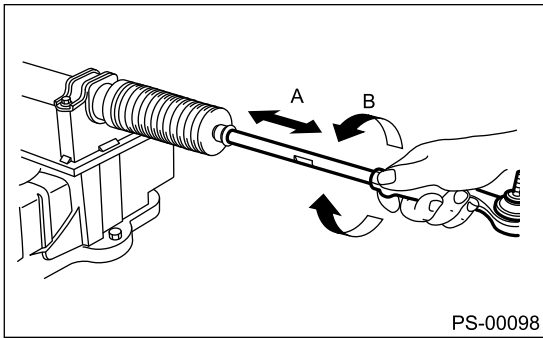

**POWER ASSISTED SYSTEM (POWER STEERING) > Electric Power Steering Gearbox**

**INSPECTION**

**1. UNIT INSPECTION**

Check components for wear, damage or other faults. Adjust or replace if necessary.

**2. LIMIT**

Make a measurements as follows. If it exceeds the specified service limits, adjust or replace.

**Note:**

**When fixing the steering gearbox assembly in a vise, apply a wooden piece on the flange portion.**

**Rack shaft sliding resistance:**

Limit: 457 N (47 kgf, 103 lbf) or less

Difference between right and left sliding resistance: 20% or less

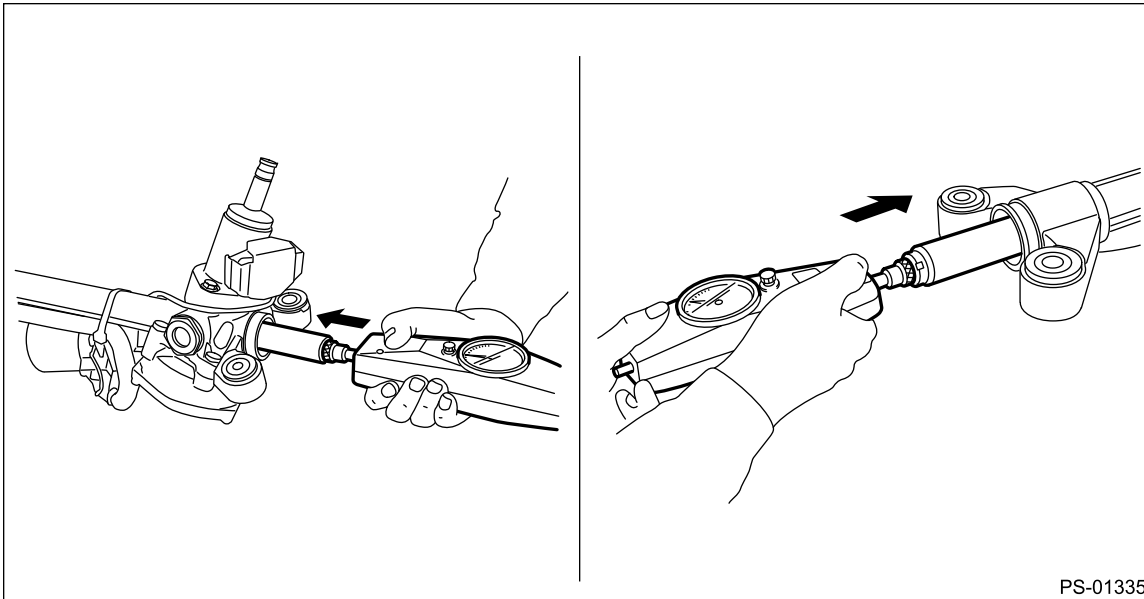

### 3. RACK SHAFT PLAY IN THE RADIAL DIRECTION

Measure the free play of rack shaft using the dial gauge and magnet stand.

**Note:**

- When fixing the steering gearbox assembly in a vise, apply a wooden piece on the flange portion.
- When fixing the magnet stand in the steering gearbox assembly, perform the following procedure.
  - Fix the iron plate on the flange portion using a c-clamp, and place the magnet stand on the iron plate.
  - Use bolts and nuts to fix directly on the flange portion of the steering gearbox assembly. (Secure the gauge firmly on the gearbox body. (Avoid the input shaft and the rack shaft.))

**Right-turn steering:**

**Service limit:**

Both amplitudes: 0.6 mm (0.024 in) or less

**Left-turn steering:**

**Service limit:**

Both amplitudes: 0.6 mm (0.024 in) or less

**Condition:**

L: 5 mm (0.2 in)

Rack shaft end P: 98 N (10 kgf, 22 lbf)

**Note:**

**<Example of dial gauge and magnet stand installation>**

**The location where the magnet stand is installed varies to stabilize the magnet stand.**

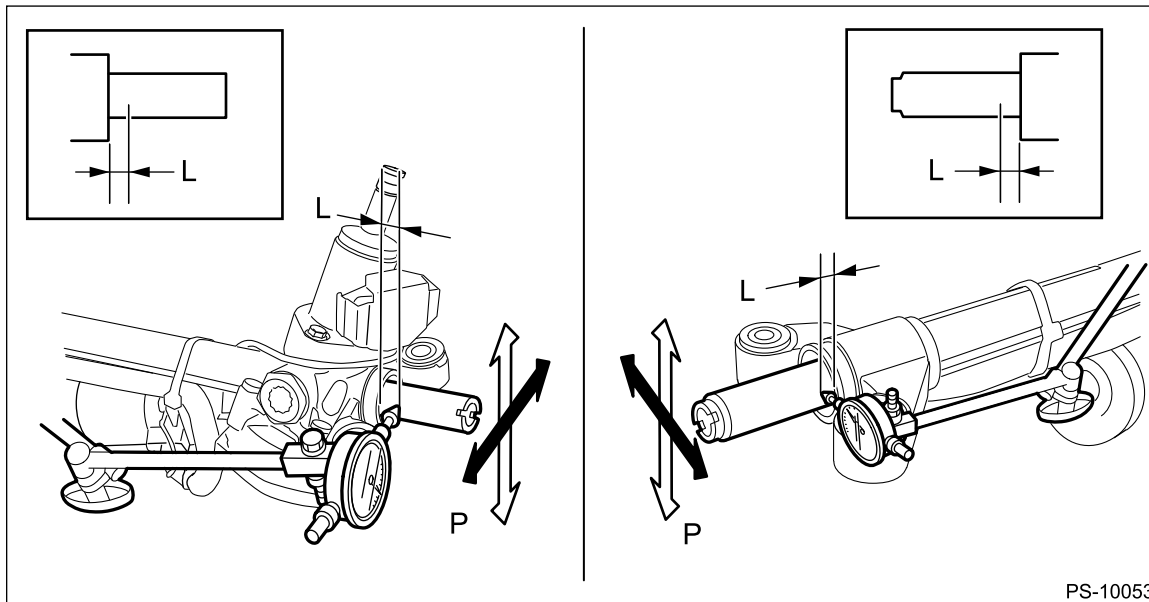

#### 4. INPUT SHAFT PLAY

Using the dial gauge and magnet stand, measure the free play of input shaft.

**Note:**

- **When fixing the steering gearbox assembly in a vise, apply a wooden piece on the flange portion.**
- **When fixing the magnet stand in the steering gearbox assembly, perform the following procedure.**
  - **Fix the iron plate on the flange portion using a c-clamp, and place the magnet stand on the iron plate.**
  - **Use bolts and nuts to fix directly on the flange portion of the steering gearbox assembly. (Secure the gauge firmly on the gearbox body. (Avoid the input shaft and the rack shaft.))**

**In radial direction:**

Limit of both amplitudes: 0.6 mm (0.024 in) or less

Condition: Input shaft tip P = 98 N (10 kgf, 22 lbf)

L: 5 mm (0.2 in) from dust cover

**In axial direction:**

Service limit: 0.27 mm (0.0106 in) or less

Condition: Input shaft tip P = 20 – 49 N (2 – 5 kgf, 4 – 11 lbf)

**Note:**

**<Example of dial gauge and magnet stand installation>**

**The location where the magnet stand is installed varies to stabilize the magnet stand.**

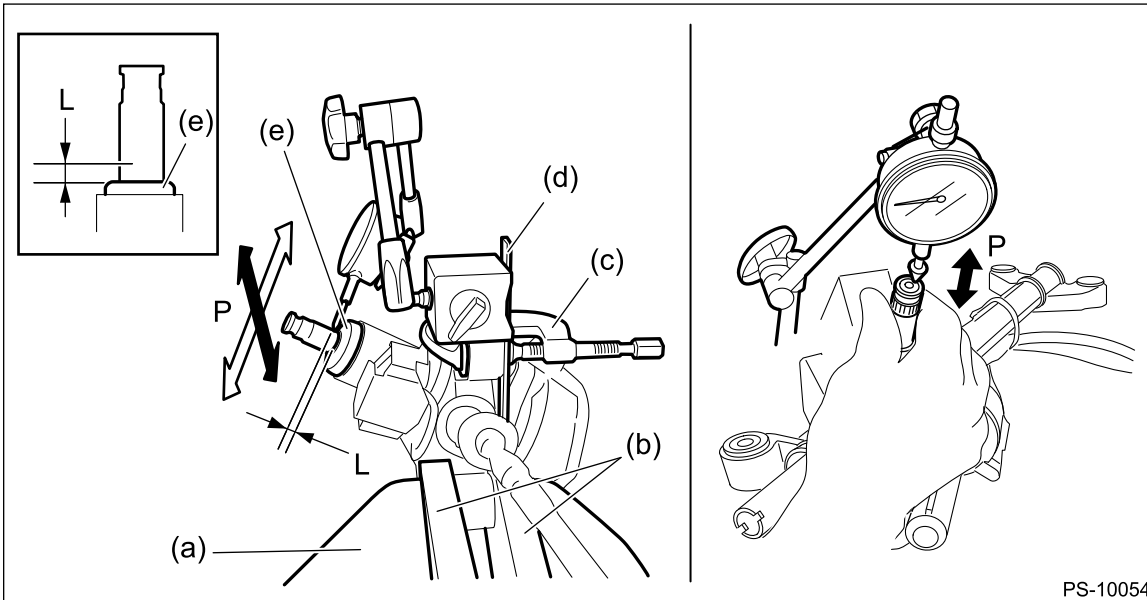

(a) Vise

(b) Wooden block

(c) C-clamp

(d) Iron plate

(e) Dust cover

## 5. ROTATIONAL RESISTANCE OF GEARBOX

Using the ST, measure the rotational resistance of the steering gearbox assembly.

**Preparation tool:**

ST: SPANNER (34099PA100)

**Service limit:**

Maximum allowable resistance: 30 N (3 kgf, 6.7 lbf) or less

Difference between right and left rotational resistance: 20% or less

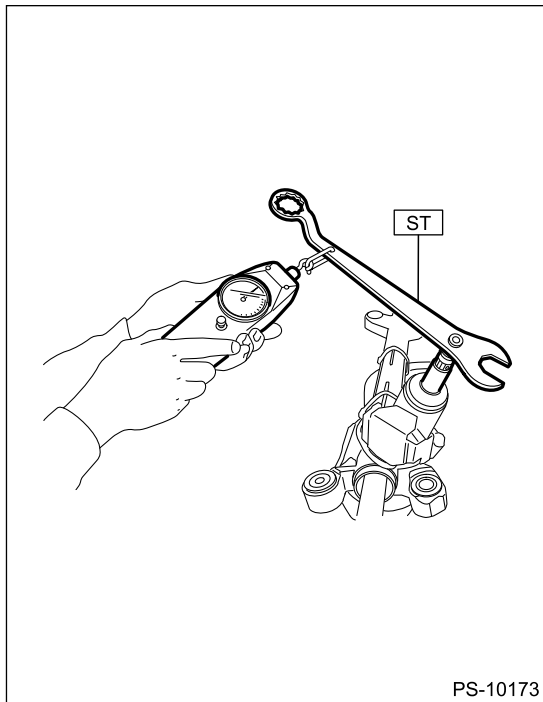

## 6. BUSHING INSPECTION

Check the bushing for cracks. If there is any cracks, replace the steering gearbox assembly.

### POWER ASSISTED SYSTEM (POWER STEERING) > Electric Power Steering Gearbox ADJUSTMENT

#### 1. GEARBOX BACKLASH ADJUSTMENT

**Caution:**

**The gearbox backlash can be adjusted only on the handle side (a). Do not adjust the backlash on the assist side (b).**

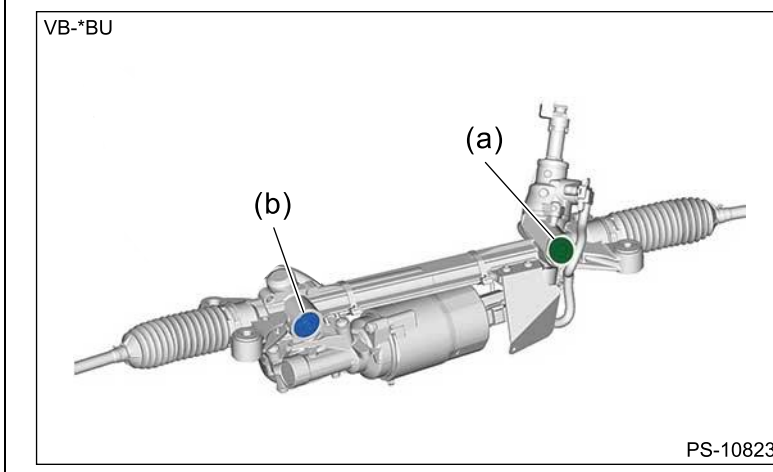

1. Remove the steering gearbox assembly.  [Ref. to POWER ASSISTED SYSTEM \(POWER STEERING\)>Electric Power Steering Gearbox>REMOVAL.](#)

2. Using the monkey wrench and 12.7 mm sq (0.5 in sq) tool, etc., loosen the lock nut and adjusting screw.
3. Apply a coat of grease to the sliding surface (B) of the pad pressure (a) and seating surface (C) of spring gearbox (b), and then insert the pad pressure (a) into steering body.
4. Charge the adjusting screw (c) with grease (D), and then insert the spring gearbox (b) into adjusting screw. Then install on the steering body.

**Preparation items:**

Grease: Multemp ACEP or equivalent

5. Apply liquid gasket to 1/3 or more (A) of entire perimeter of adjusting screw thread (c).

**Preparation items:**

Liquid gasket: THREE BOND 1111B or equivalent

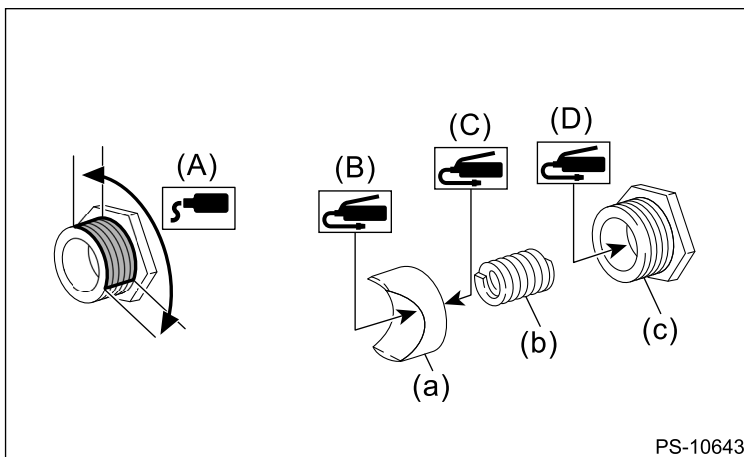

6. Tighten the adjusting screw to 25 N·m (2.5 kgf-m, 18.4 ft-lb), then loosen it.
7. Tighten the adjusting screw to 10 N·m (1.0 kgf-m, 7.4 ft-lb).
8. Loosen the adjusting screw by 55°.
9. While fixing the adjusting screw, tighten the lock nuts.

**Tightening torque:**

45 N·m (4.6 kgf-m, 33.2 ft-lb)

## 2. FRONT WHEEL ALIGNMENT ADJUSTMENT

1. Adjust the front toe-in. [📄 Ref. to FRONT SUSPENSION>Wheel Alignment>ADJUSTMENT > FRONT TOE-IN.](#)
2. Check the steering angle of the wheels.



**Standard of steering angle:**

Model	Inner wheel	Outer wheel
17-inch model	37.2°	32.8°
18-inch model	37.1°	32.7°

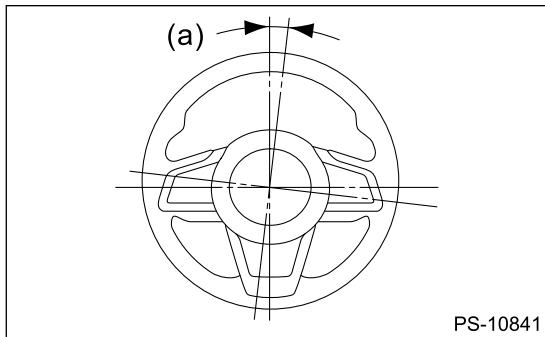
3. When the steering wheel is in the following condition, perform the steering wheel installation over again.
  - When the steering wheel is set in the straight ahead position, the steering wheel spokes are not horizontal.
  - Error is more than 5° on the periphery of the steering wheel.



(a) Within 5°

4. If the steering wheel spokes are not horizontal with vehicle set in the straight ahead position after this adjustment, correct it by turning the right and left tie-rods in the opposite direction from each other by the same angle. Also check that there is no abnormal steering effort, failure of the steering wheel to return, or other faults.
5. Perform "VDC sensor midpoint setting mode".  [Ref. to VEHICLE DYNAMICS CONTROL \(VDC\)>VDC Control Module and Hydraulic Control Unit \(VDCCM&H/U\)>ADJUSTMENT > VDC SENSOR MIDPOINT SETTING MODE.](#)
6. Perform the lane keep assist learning value clear.  [Ref. to EyeSight \(DIAGNOSTICS\)>Work Support.](#)

## POWER ASSISTED SYSTEM (POWER STEERING) > Tie-rod end

### REMOVAL



1. Remove the front wheels.  Ref. to [WHEEL AND TIRE SYSTEM>Tire and Wheel>REMOVAL](#).
2. Disconnect the tie-rod end.
  - (1) Remove the cotter pin (a).
  - (2) Remove the castle nut (b).
  - (3) Using a ball joint puller (d), remove the tie-rod end (c).

#### Caution:

- Be careful not to damage the boot of the ball joint.
- Be careful not to damage the peripheral parts.

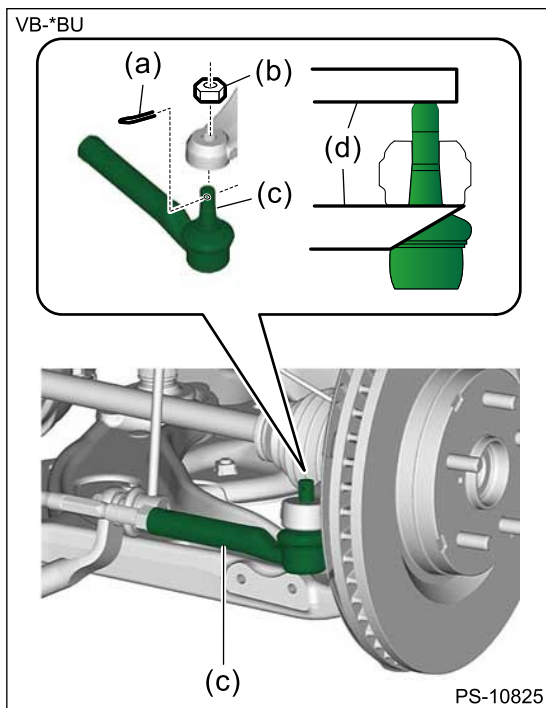

3. Loosen the lock nut, and remove the tie-rod end.

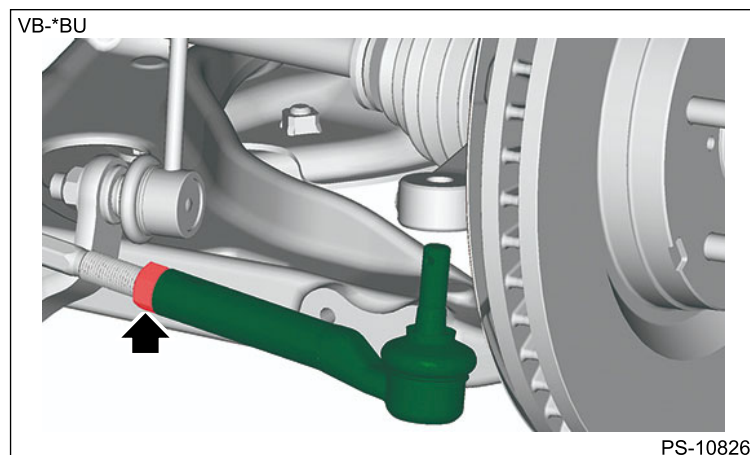

## POWER ASSISTED SYSTEM (POWER STEERING) > Tie-rod end

### INSTALLATION

---

1. Connect the tie-rod ends.

**Caution:**

**Do not apply grease, etc. to the tapered portion of ball stud.**

- (1) Tighten the castle nut.

**Note:**

**If the ball stud hole and the cutout portion of the castle nut are not aligned after tightening, tighten the castle nut within the range of 60° to align with each other.**

**Tightening torque:**

27 N·m (2.8 kgf-m, 19.9 ft-lb)

- (2) Install a new cotter pin.

2. Install the front wheels.  [Ref. to WHEEL AND TIRE SYSTEM>Tire and Wheel>INSTALLATION.](#)

3. After adjusting toe-in and steering angle, tighten the lock nut on tie-rod end.

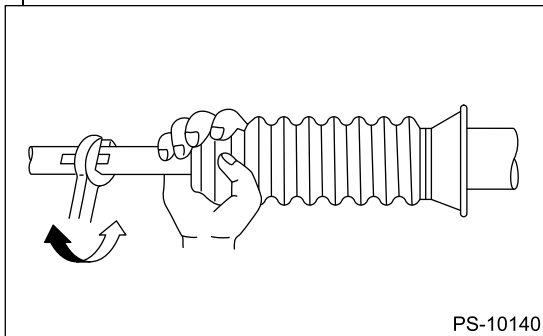

**Note:**

**When adjusting toe-in, hold the boot steering gearbox as shown to prevent it from being rotated or twisted. If it becomes twisted, straighten it.**



**Tightening torque:**

85 N·m (8.7 kgf-m, 62.7 ft-lb)

4. Perform "VDC sensor midpoint setting mode".  [Ref. to VEHICLE DYNAMICS CONTROL \(VDC\)>VDC Control Module and Hydraulic Control Unit \(VDCCM&H/U\)>ADJUSTMENT > VDC SENSOR MIDPOINT SETTING MODE.](#)
5. Perform the lane keep assist learning value clear.  [Ref. to EyeSight \(DIAGNOSTICS\)>Work Support.](#)

## POWER ASSISTED SYSTEM (POWER STEERING) > Tie-rod end

### INSPECTION

---

#### 1. ON THE VEHICLE INSPECTION

1. Check that there is no deformation, cracks or other damages.
2. Check for excessive rusting.
3. Check the front hub unit bearing for looseness.  [Ref. to PROPELLER SHAFT / DRIVE SHAFT / AXLE>Front Hub Unit Bearing>INSPECTION.](#)
4. Rock the tie-rod end up and down to check the ball joint for looseness.

BT-\*BE

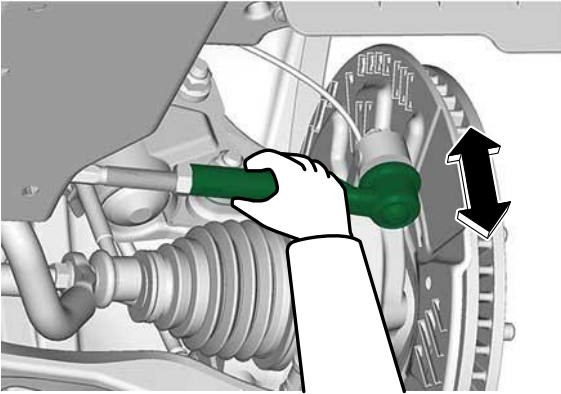

PS-10799

5. If fault is found in the inspection, replace the relevant part.

## 2. UNIT INSPECTION

1. Move the stud as shown in the figure to check that there is no abnormal interference or play.

ZD-\*AJ

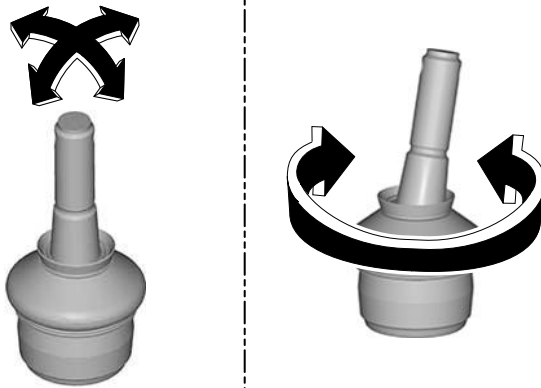



FS-10585

2. If fault is found in the inspection, replace the relevant part.

## POWER ASSISTED SYSTEM (POWER STEERING) > General Diagnostic Table

### INSPECTION

Trouble	Possible cause	Corrective action
<ul style="list-style-type: none"> <li>Steering effort is heavy in all ranges.</li> <li>Steering effort is heavy at stand still.</li> <li>Steering wheel vibrates when turning.</li> </ul>	1. Tire and wheel <ul style="list-style-type: none"> <li>Improper tire out of specifications</li> <li>Improper wheel out of specification</li> <li>Tires not properly inflated</li> </ul>	Replace the tire and wheel, or reinflate the tire.
	2. Measure the steering wheel effort.  <a href="#">Ref. to POWER ASSISTED SYSTEM (POWER STEERING)&gt;General Diagnostic Table&gt;INSPECTION &gt; MEASUREMENT OF STEERING EFFORT.</a>	Adjust or replace the faulty parts.
<ul style="list-style-type: none"> <li>Vehicle leads to one side or the other.</li> <li>Returning force of steering wheel to center is poor.</li> <li>Steering wheel vibrates when turning.</li> </ul>	1. Tire and wheel <ul style="list-style-type: none"> <li>Flat tire</li> <li>Mixed use of different tires</li> <li>Mixed use of different wheels</li> <li>Abnormal wear of tire</li> <li>Unequal tread remaining</li> <li>Unequal pressure of tire</li> </ul>	Adjust, repair or replace the tire and wheel.
	2. Front wheel alignment <ul style="list-style-type: none"> <li>Improper or unequal caster</li> <li>Improper or unequal toe-in</li> <li>Loose suspension connections</li> </ul>	Adjust or retighten.
	3. Measure the steering wheel effort.  <a href="#">Ref. to POWER ASSISTED SYSTEM (POWER STEERING)&gt;General Diagnostic Table&gt;INSPECTION &gt; MEASUREMENT OF STEERING EFFORT.</a>	Adjust or replace the faulty parts.

#### Note:

When performing repeated steering operation with the vehicle at standstill, the steering effort may be temporarily heavy because the heat generated in the system activates the power steering protection control. This is not a malfunction caused by the steering system. After a while, it will return to normal steering effort. (In this case, the steering warning light will not come on and there will be no DTC.)

## 1. NOISE AND VIBRATION

#### Note:

- When turning the steering wheel with the brake applied when the vehicle is parked, a screeching noise may be generated by the brake disc and pads. This is not a fault in the steering system.
- There may be a small vibration around the steering devices when turning the steering wheel at standstill, even though the component parts are operating properly.

<b>Trouble</b>	<b>Possible cause</b>	<b>Corrective action</b>
Rattling noise (intermittent) While engine is running	Interference with adjacent parts	Check the clearance. Correct if necessary.
	Looseness of linkage, play of steering, improper tightening (looseness) of suspension joint or steering column	Retighten or replace.
	Noise emitted from inside of the gearbox	Replace the gearbox assembly.
Knocking When turning steering wheel in both directions with small angle repeatedly at engine ON or OFF.	Excessive backlash Loosened lock nut for adjusting backlash	Adjust the backlash. When the noise remains after adjustment, replace the gearbox assembly.
	Insufficient tightening or play in the tie-rod or tie-rod end	Retighten or replace.
Grinding noise (intermittent) When engine operates (when operating steering wheel)	Fault inside of gearbox	Replace the gearbox assembly.
	Faulty bearing of the column assembly steering	Apply grease or replace.
	Occurs when turning the steering wheel with brakes (service or parking) applied.	If the noise goes off when brake is released, it is normal.
Vibration While engine is running with/without steering turned.	Excessive play in steering, looseness of suspension parts	Retighten.

## 2. MEASUREMENT OF STEERING EFFORT

### 1. CHECK STEERING WARNING LIGHT.

Does the steering warning light illuminate?

Yes

Using Subaru Select Monitor, read the DTC and inspect according to it.  [Ref. to POWER STEERING \(DIAGNOSTICS\)>Diagnostic Trouble Code \(DTC\).](#)

No

 [Go to 2.](#)

## 2. CHECK STEERING WARNING LIGHT.

1. Using Subaru Select Monitor, display [EPS operating condition] in [Data monitor] of [Power Steering].  [Ref. to COMMON \(DIAGNOSTICS\)>Data Monitor.](#)
2. Connect the Subaru Select Monitor, and turn the steering wheel. (One lock to lock)

Does the [EPS operating condition] display [No Trouble] without displaying any DTC?

Yes

 [Go to 3.](#)

No

If the [EPS operating condition] is [Assist limitation], stop the engine for approx. 30 minutes and perform the procedures from step 1 again.

## 3. CHECK STEERING EFFORT.

1. Stop the vehicle on paved road.
2. Set the tire air pressure to the specification.
3. Start the engine.
4. Run the engine at idle.
5. Install a spring scale on the steering wheel.
6. Pull the spring scale at a right angle to the steering wheel, and measure both right and left steering wheel efforts.

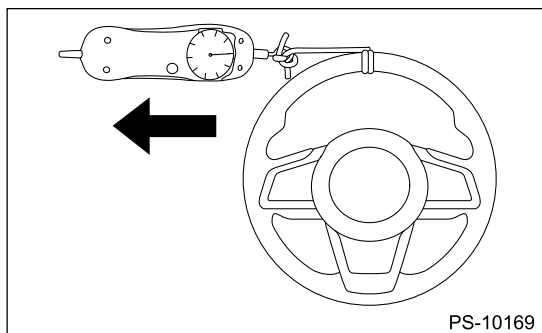

Is the steering effort less than 31 N (3.2 kgf, 7 lbf)?

Yes

 [Go to 8.](#)

No

 [Go to 4.](#)

#### 4. CHECK STEERING EFFORT.

1. Stop the engine.
2. Pull the spring scale at a right angle to the steering wheel, and measure both right and left steering wheel efforts.

Is the steering effort less than 294.2 N (30 kgf, 66.2 lbf)?

Yes

 [Go to 5.](#)

No

Perform the inspection or adjustment around the suspension part.

#### 5. CHECK TORQUE SENSOR OUTPUT VALUE.

1. Using the Subaru Select Monitor, display the following items in the [Data monitor] of [Power Steering].  [Ref. to COMMON \(DIAGNOSTICS\)>Data Monitor.](#)
  - [Torque Sensor Main]
  - [Torque Sensor Sub]
2. Read the value of torque sensor.

**Note:**

**When measuring, place the steering wheel at the center position.**

Is the torque value  $-0.75 \text{ N}\cdot\text{m} - 0.75 \text{ N}\cdot\text{m}$  ( $-0.08 \text{ kgf}\cdot\text{m} - 0.08 \text{ kgf}\cdot\text{m}$ ,  $-0.55 \text{ ft}\cdot\text{lb} - 0.55 \text{ ft}\cdot\text{lb}$ )?



Yes

 [Go to 8.](#)

No

 [Go to 6.](#)

## 6. CHECK TORQUE SENSOR OUTPUT VALUE.

1. Remove the universal joint assembly steering.  [Ref. to POWER ASSISTED SYSTEM \(POWER STEERING\)>Universal Joint>REMOVAL.](#)
2. Using the Subaru Select Monitor, display the following items in the [Data monitor] of [Power Steering].  [Ref. to COMMON \(DIAGNOSTICS\)>Data Monitor.](#)
  - [Torque Sensor Main]
  - [Torque Sensor Sub]
3. Read the value of torque sensor.

Is the torque value  $-0.75 \text{ N}\cdot\text{m} - 0.75 \text{ N}\cdot\text{m}$  ( $-0.08 \text{ kgf}\cdot\text{m} - 0.08 \text{ kgf}\cdot\text{m}$ ,  $-0.55 \text{ ft}\cdot\text{lb} - 0.55 \text{ ft}\cdot\text{lb}$ )?

Yes

 [Go to 7.](#)

No

Replace the gearbox assembly.  [Ref. to POWER ASSISTED SYSTEM \(POWER STEERING\)>Electric Power Steering Gearbox.](#)

## 7. CHECK TORQUE SENSOR OUTPUT VALUE.

1. Install the universal joint assembly steering.  [Ref. to POWER ASSISTED SYSTEM \(POWER STEERING\)>Universal Joint>INSTALLATION.](#)

### Note:

**Check that the universal joint assembly steering moves up and down smoothly without installing the bolt. Then tighten the bolts first on the gearbox side and then on the column shaft side.**

2. Using the Subaru Select Monitor, display the following items in the [Data monitor] of [Power Steering].  [Ref. to COMMON \(DIAGNOSTICS\)>Data Monitor.](#)
  - [Torque Sensor Main]
  - [Torque Sensor Sub]
3. Read the value of torque sensor.

Is the torque value  $-0.75 \text{ N}\cdot\text{m} - 0.75 \text{ N}\cdot\text{m}$  ( $-0.08 \text{ kgf}\cdot\text{m} - 0.08 \text{ kgf}\cdot\text{m}$ ,  $-0.55 \text{ ft}\cdot\text{lb} - 0.55 \text{ ft}\cdot\text{lb}$ )?

Yes

 [Go to 8.](#)

No

Check the universal joint assembly steering.  [Ref. to POWER ASSISTED SYSTEM \(POWER STEERING\)>Universal Joint>INSPECTION.](#)

## 8. CHECK STEERING WHEEL EFFORT.

1. Remove the universal joint assembly steering.  [Ref. to POWER ASSISTED SYSTEM \(POWER STEERING\)>Universal Joint>REMOVAL.](#)
2. Measure the steering wheel effort.

Is the steering effort less than 2.26 N (0.23 kgf, 0.51 lbf)?

Yes

 [Go to 9.](#)

No

Replace the column assembly steering.  [Ref. to POWER ASSISTED SYSTEM \(POWER STEERING\)>Steering Column.](#)

## 9. CHECK STEERING WHEEL EFFORT.

Measure the steering wheel effort.

Is the difference of steering effort between right and left less than 20%?

Yes

 [Go to 10.](#)

No

Replace the steering column.  [Ref. to POWER ASSISTED SYSTEM \(POWER STEERING\)>Steering Column.](#)

## 10. CHECK UNIVERSAL JOINT ASSEMBLY STEERING.

Measure the swing torque of joint. (Yoke of steering column side)  [Ref. to POWER ASSISTED SYSTEM \(POWER STEERING\)>Universal Joint>INSPECTION.](#)

Is the swing torque of the universal joint assembly steering 5.4 N (0.55 kgf, 1.21 lbf) or less?

Yes

 [Go to 11.](#)

No

Replace the universal joint assembly steering with a new part.  [Ref. to POWER ASSISTED SYSTEM \(POWER STEERING\)>Universal Joint.](#)

## 11. CHECK UNIVERSAL JOINT ASSEMBLY STEERING.

Measure the swing torque of joint. (Yoke of gearbox side)  [Ref. to POWER ASSISTED SYSTEM \(POWER STEERING\)>Universal Joint>INSPECTION.](#)

Is the swing torque of the universal joint assembly steering 4.5 N (0.46 kgf, 1.01 lbf) or less?

Yes

 [Go to 12.](#)

No

Replace the universal joint assembly steering with a new part.  [Ref. to POWER ASSISTED SYSTEM \(POWER STEERING\)>Universal Joint.](#)

## 12. CHECK FRONT WHEEL.

Check the front wheels.

Does the front wheels have unsteady revolution or rattling, or does the brake drag?

Yes

Inspect, readjust and replace if necessary.

No

 [Go to 13.](#)

## 13. CHECK TIE-ROD AND TIE-ROD ENDS.

Remove the tie-rod and tie-rod ends.

Does the tie-rod and tie-rod end have unsteady revolution, swing or rattling?

Yes

Inspect and replace if necessary.

No

 [Go to 14.](#)

## 14. CHECK FRONT ARM.

Remove the arm assembly front.

Does the ball joint section of arm assembly front have unsteady revolution or rattling?

Yes

Inspect and replace if necessary.

No

 [Go to 15.](#)

## 15. CHECK GEARBOX.

Measure the rotating of gearbox.  [Ref. to POWER ASSISTED SYSTEM \(POWER STEERING\)>Electric Power Steering Gearbox>INSPECTION > ROTATIONAL RESISTANCE OF GEARBOX.](#)

Is the rotational resistance of the steering gearbox 30 N (3 kgf, 6.7 lbf) or less? Is the difference between the right and left rotational resistances equal to or less than 20%?

Yes

 [Go to 16.](#)

No

Replace the gearbox assembly.  [Ref. to POWER ASSISTED SYSTEM \(POWER STEERING\)>Electric Power Steering Gearbox.](#)

## 16. CHECK GEARBOX.

Measure the sliding of gearbox.  [Ref. to POWER ASSISTED SYSTEM \(POWER STEERING\)>Electric Power Steering Gearbox>INSPECTION > LIMIT.](#)

Is the sliding resistance of the steering gearbox equal to or less than 457 N (47 kgf, 103 lbf)? Is the difference between right and left sliding resistances equal to or less than 20%?

Yes

Steering effort is normal.

No

Replace the gearbox assembly.  [Ref. to POWER ASSISTED SYSTEM \(POWER STEERING\)>Electric Power Steering Gearbox.](#)

## 3. INSPECTION OF CLEARANCE

This table lists various clearances that must be correctly adjusted to ensure the normal vehicle driving without interfering noise, or any other faults.

Location	Minimum allowance mm (in)
(1) Universal joint column side yoke to Master cylinder (closest point of approach when the universal joint turns by 360°)	5 (0.20)
(2) Torque sensor to Crossmember	5 (0.20)
(3) Stub housing to Engine mount	10 (0.39)
(4) Motor CM to Crossmember	There must be no contact
(5) Worm wheel housing to Crossmember	There must be no contact

VB-\*BU

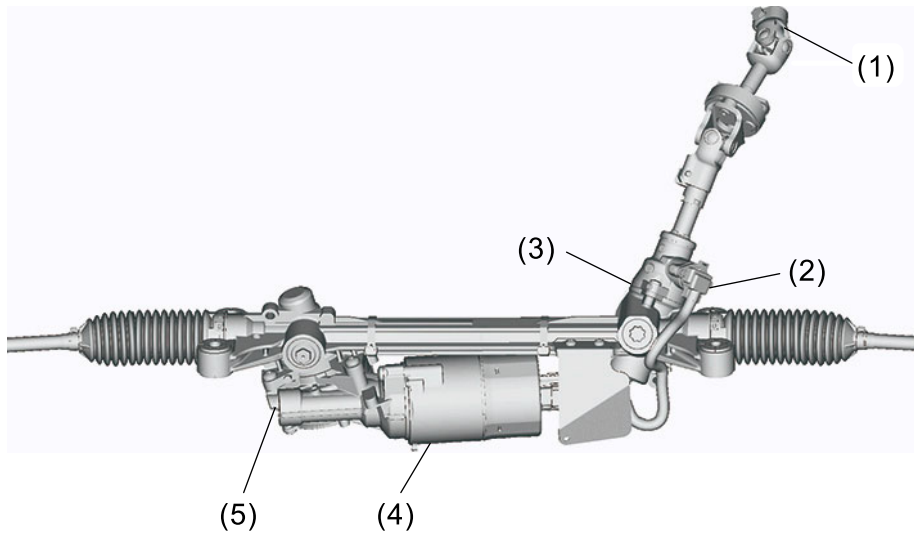

PS-10824