

# AIRBAG SYSTEM

**AB**



---

1. General Description
2. Airbag Connector
3. Inspection Locations after a Collision
4. Driver's Airbag Module
5. Knee Airbag Module
6. Passenger's Airbag Module
7. Side Airbag Module
8. Curtain Airbag Module
9. Airbag Control Module
10. Impact Sensor
11. Roll Connector
12. Airbag Module Disposal (Deployment Processing on Vehicle)

## AIRBAG SYSTEM > General Description

### CAUTION

#### 1. BEFORE STARTING ALL WORKS

- When performing service operation, refer to "Repair Contents" in "General Description".  [Ref. to REPAIR CONTENTS>Repair Contents.](#)
- When performing work on the sensors or modules, be careful of the following.
  - Before disconnecting electrical connectors, be sure to disconnect the ground terminal from the battery sensor.  [Ref. to REPAIR CONTENTS>NOTE > BATTERY.](#)
  - Do not apply any impact. If the parts are accidentally dropped, replace with a new part.
  - Do not expose to high-temperature and humidity.
- The airbag system (including pretensioner) is fitted with a backup power supply. After disconnecting the ground terminal from the battery sensor, the airbag may operate if you do not wait for 60 seconds or more before starting the service of airbag system.
- When performing an operation with the airbag system parts including pretensioners exposed, do not apply any impact to airbag modules and impact sensors.
- If the airbag warning light illuminates, check or repair the vehicle immediately to prevent it from airbag system malfunction.
- For the operation that is required to use special tools, always follow the instructions.
- Do not allow water or oil to come in contact with the connector terminals. Also, do not touch the connector terminals directly.

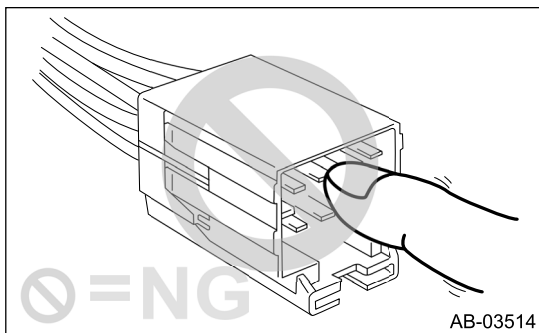

- If damage, open circuit or rust is found on airbag system wiring harness, do not repair the harness. Always replace the faulty harness with a new genuine part.

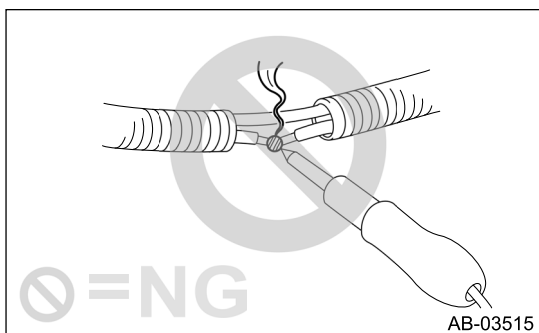

- When painting or performing sheet metal work on the vehicle, remove the following parts. Performing the work without removing the parts may cause secondary malfunction.

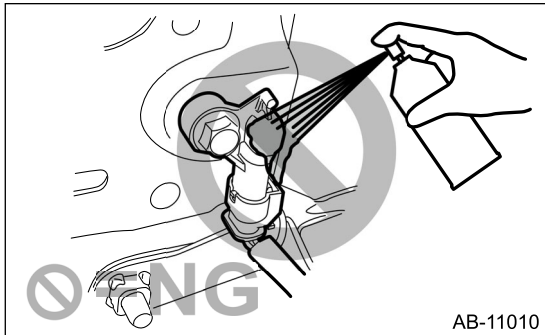

- Front part of the vehicle including the front wheel apron, front fender and radiator panel side
  - Front impact sensor
  - Wiring harness
- Side or its vicinity of the vehicle including the side sill, center pillar, front doors, rear doors and rear fender
  - Side impact sensor (front door)
  - Side impact sensor (center pillar)
  - Side impact sensor (rear wheel house)
  - Side impact sensor (under the rear center seat)
  - Wiring harness
- When attaching the steering wheel assembly and steering roll connector, be sure to adjust the steering roll connector.

## 2. BEFORE STARTING PARTS REPLACEMENT

- If the following parts are deformed or damaged, replace them with new parts.
  - Impact sensors and brackets
  - Airbag modules and brackets
  - Airbag control module
  - Pretensioners and brackets
  - Harnesses
  - Plate sensor cover (Side impact sensor (under the rear center seat))
  - Pad front door inner
- Install the wiring harness securely with the specified clips to avoid interference or tangled with other parts.

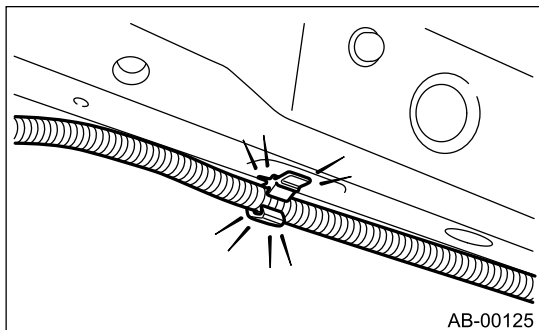

- Do not use the airbag or pretensioner parts from other vehicles. Always replace the defective parts with new parts.
- Never reuse any activated airbag module and pretensioner.

- Do not discard undeployed airbag module or pretensioner. For the disposal procedures, refer to "Airbag Module Disposal".
- For parts which are not reusable, always use new parts.  [Ref. to AIRBAG SYSTEM>General Description>COMPONENT.](#)
- When attaching the steering wheel assembly and steering roll connector, be sure to adjust the steering roll connector.
- After removing each part of the airbag system, keep them with the pad side facing upward on a dry, clean and flat surface away from heat, light sources, moisture and dust.

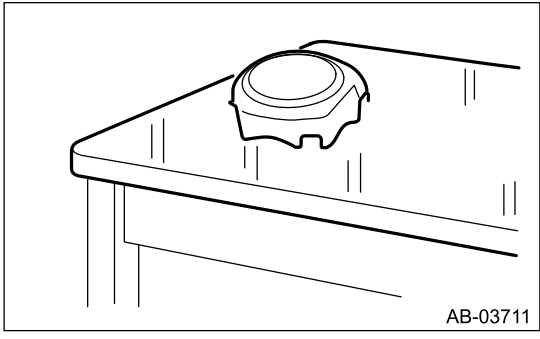

- Observe the following; the airbag system component or the internal parts of seat belt pretensioner may be damaged or the reliability may be greatly lowered.
  - Do not drop or otherwise apply impact.
  - Do not store it under high temperature environment at 85°C (185°F) or more, or do not near it to open flames.
  - Do not allow water, oil or grease to come in contact.

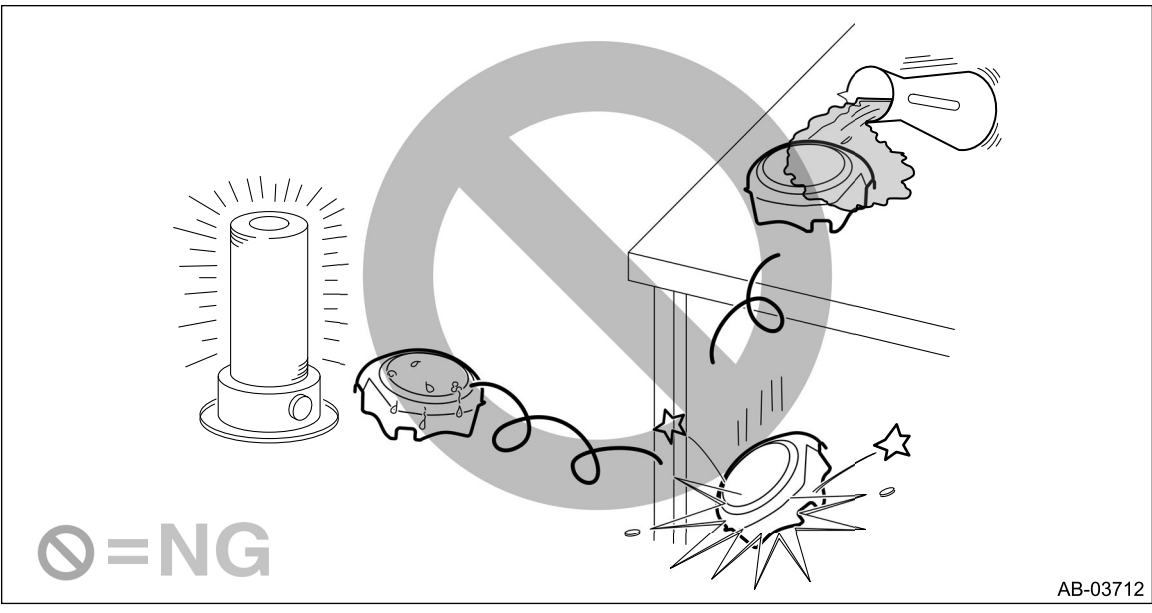

- When storing a removed airbag module, observe the following items. If the pad of the airbag module is in contact with other objects, it may cause a serious accident if the airbag accidentally operates.
  - Do not place the airbag module with the pad side facing downward.
  - Do not place any objects on the airbag module.
  - Do not pile up the airbag module.
- Driver's airbag module

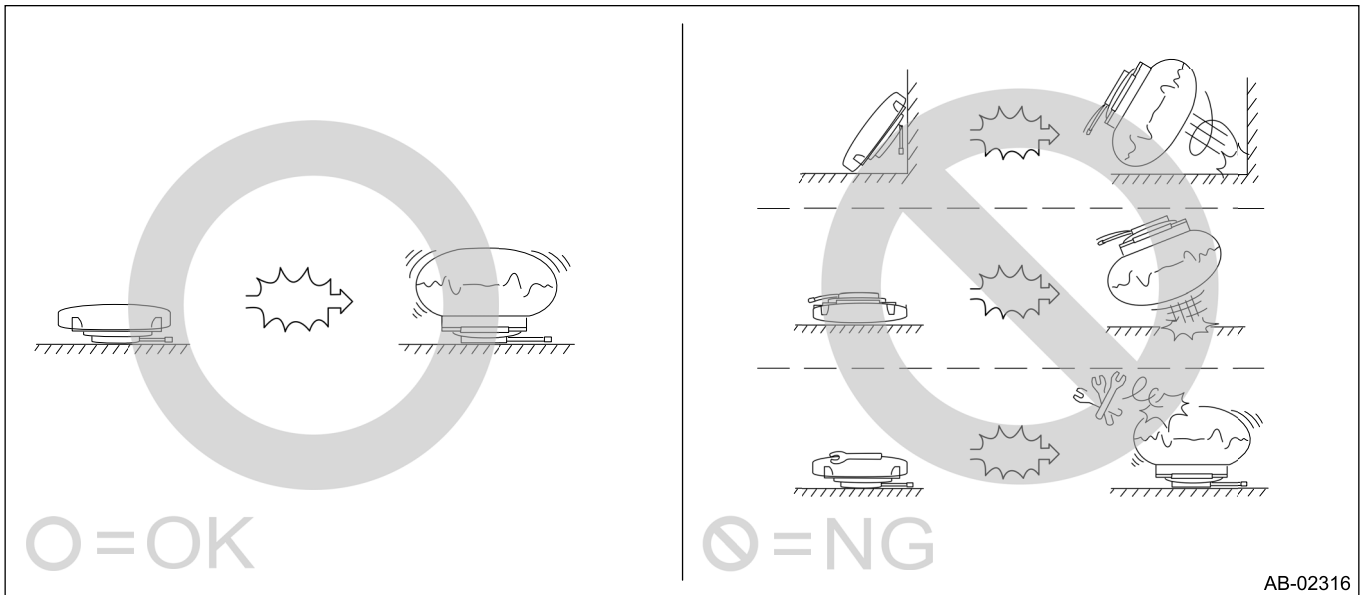

- Passenger's airbag module and side airbag module

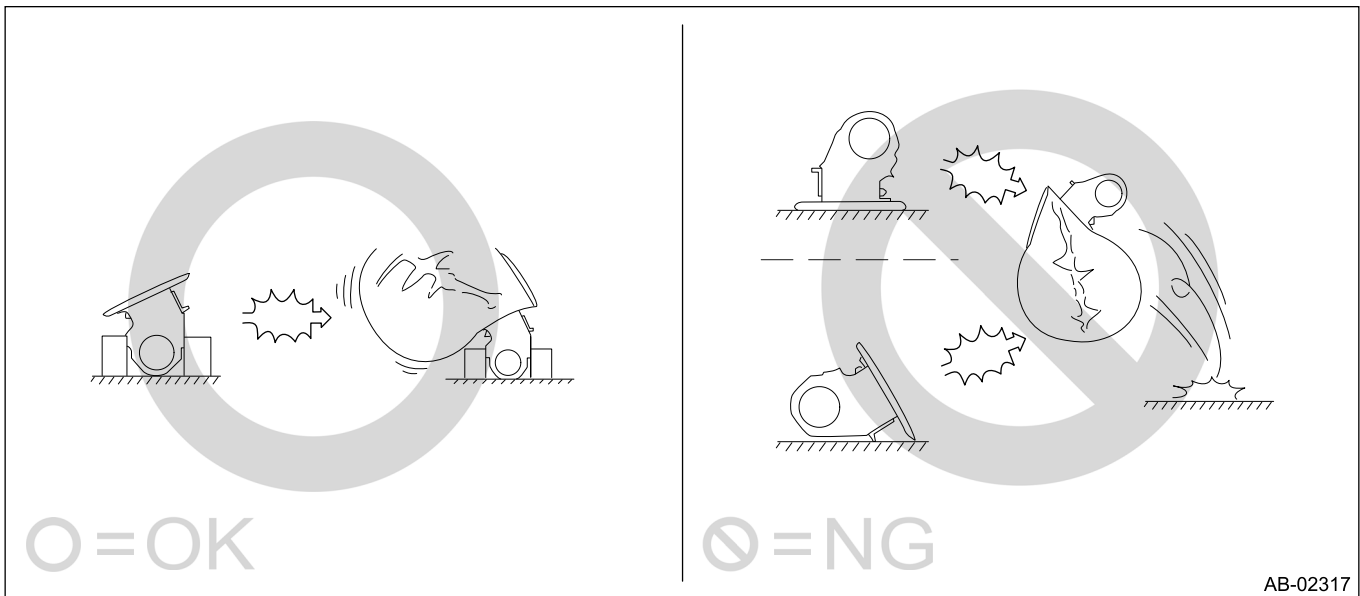

- Do not disassemble the airbag modules and pretensioners.

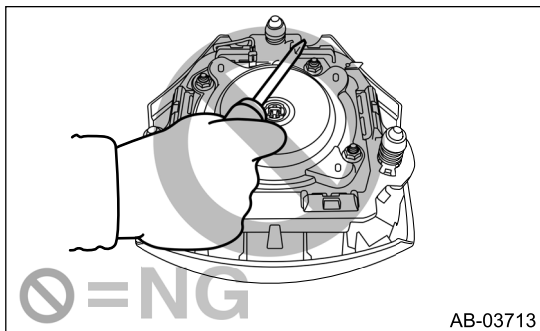

- The removed front seat with airbag module must be kept at least 200 mm (8 in) away from walls and other objects.

### 3. BEFORE STARTING TROUBLESHOOTING

- Even if any part must be replaced as the result of troubleshooting, do not use an airbag part or pretensioner part from other vehicles. Always replace the defective parts with new parts.
- When checking the airbag system, be sure to use a digital circuit tester. Use of an analog circuit tester may cause the airbag to activate erroneously due to a minimal current inside tester.

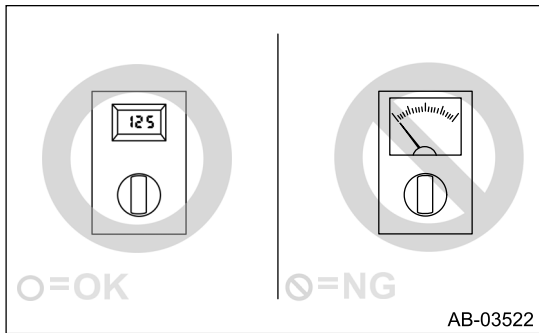

- For the operation that is required to use special tools, always follow the instructions.
- When checking, use a test harness. Damage to connector terminal causes malfunction. Do not directly put the tester probe on airbag connector terminal.

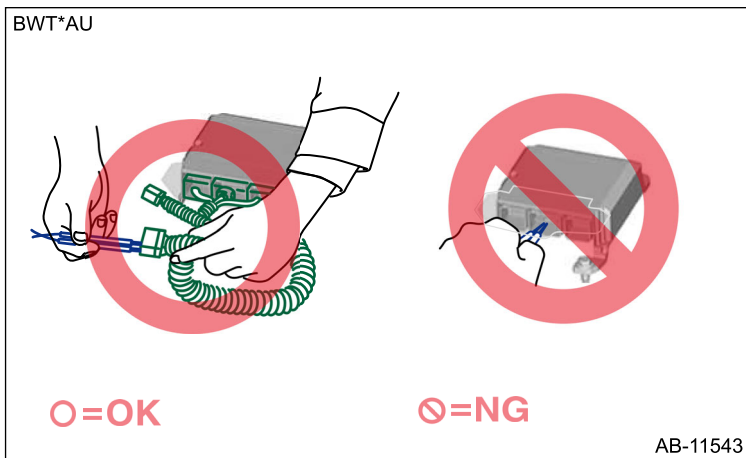

- Do not check the continuity of airbag modules and pretensioners.

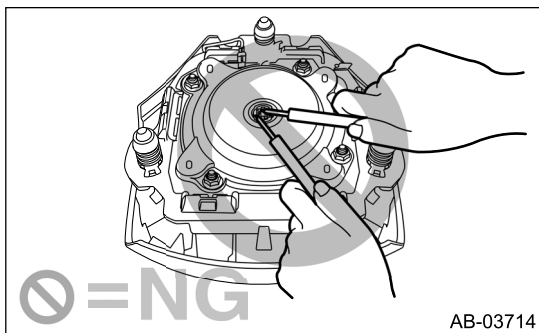

## AIRBAG SYSTEM > General Description

### LOCATION

---

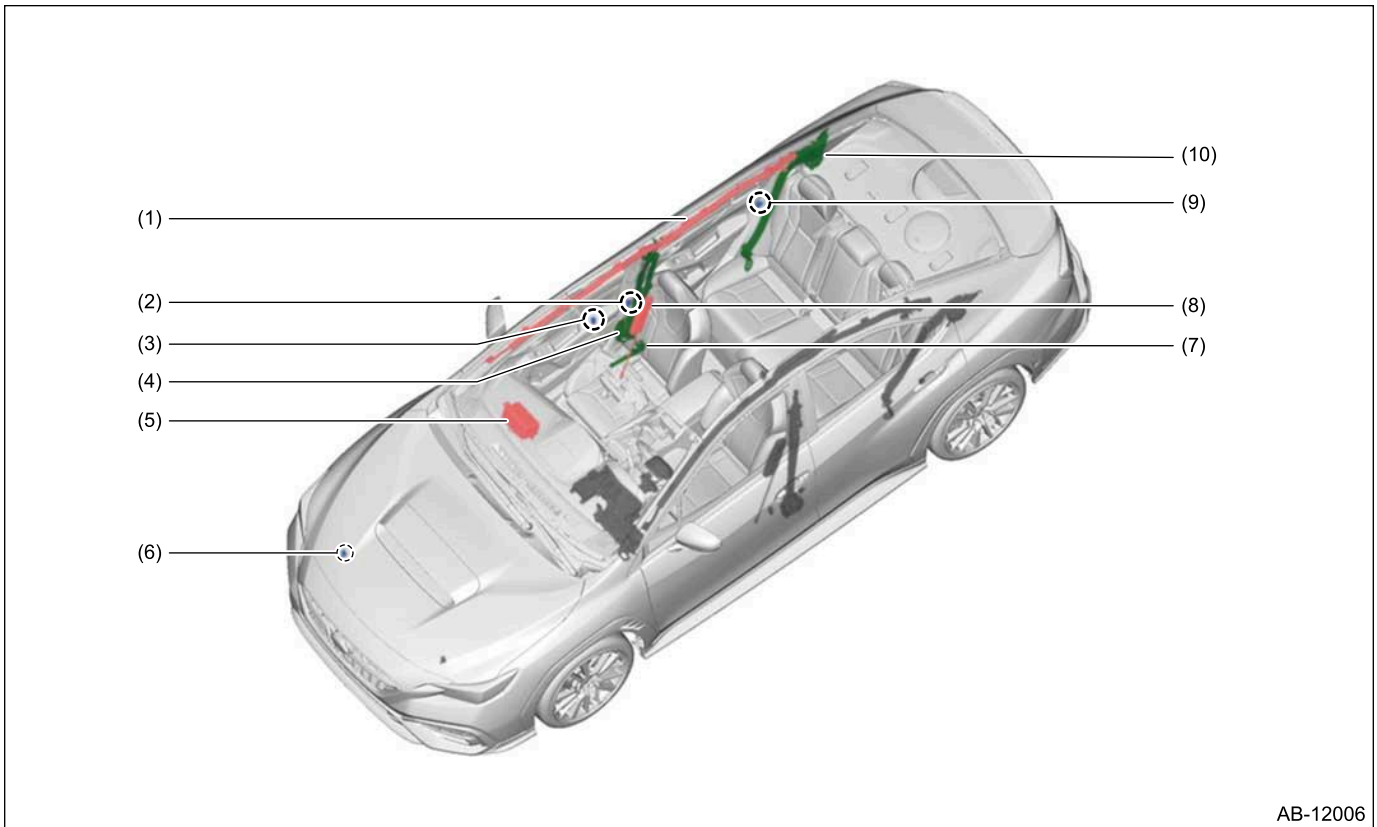

AB-12006

- |  |                                   |  |
|--|-----------------------------------|--|
| (1) Curtain airbag module RH                                 | (5) Passenger's airbag module     | (9) Side impact sensor RH (rear wheel house) |
| (2) Side impact sensor RH (center pillar)                    | (6) Front impact sensor RH        | (10) Rear seatbelt pretensioner RH           |
| (3) Side impact sensor RH (front door)                       | (7) Lap seat belt pretensioner RH |  |
| (4) Front seat belt pretensioner & adaptive force limiter RH | (8) Side airbag module RH         |  |

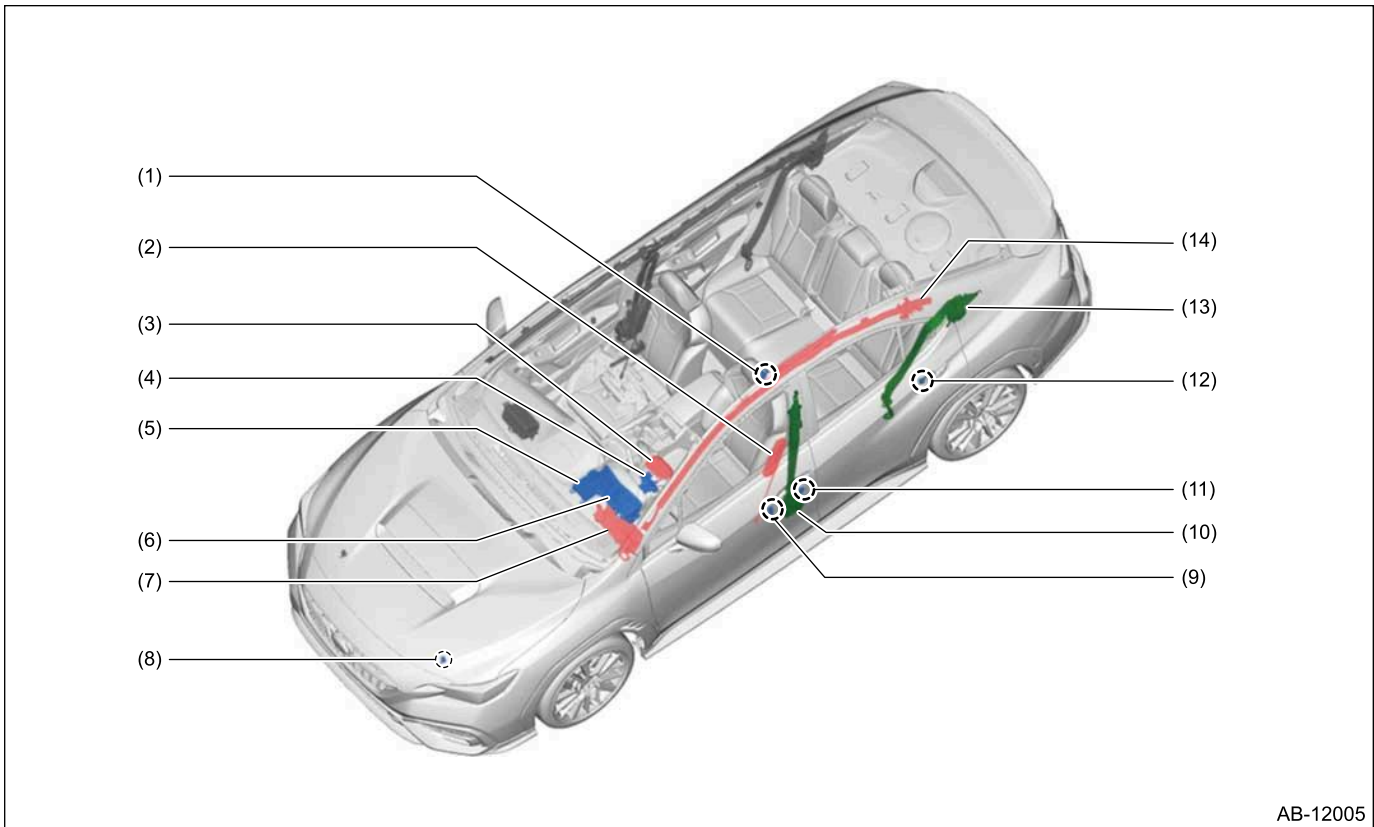

AB-12005

- |  |   |   |
|--|---|---|
| (1) Side impact sensor (under rear seat) | (6) Airbag warning light (in combination meter) | (11) Side impact sensor LH (center pillar)    |
| (2) Side airbag module LH                | (7) Knee airbag module                          | (12) Side impact sensor LH (rear wheel house) |
| (3) Driver's airbag module               | (8) Front impact sensor LH                      | (13) Rear seat belt pretensioner LH           |
| (4) Steering roll connector              | (9) Side impact sensor LH (front door)          | (14) Curtain airbag module LH                 |
| (5) Airbag control module                | (10) Front seat belt pretensioner LH            |   |

**Note:**

**For the occupant detection system, refer to "OCCUPANT DETECTION SYSTEM" of "AIRBAG (DIAGNOSTICS)" section.  Ref. to AIRBAG(DIAGNOSTICS)>Electrical Component Location>LOCATION > OCCUPANT DETECTION SYSTEM.**

**COMPONENT**

**1. DRIVER'S AIRBAG MODULE**

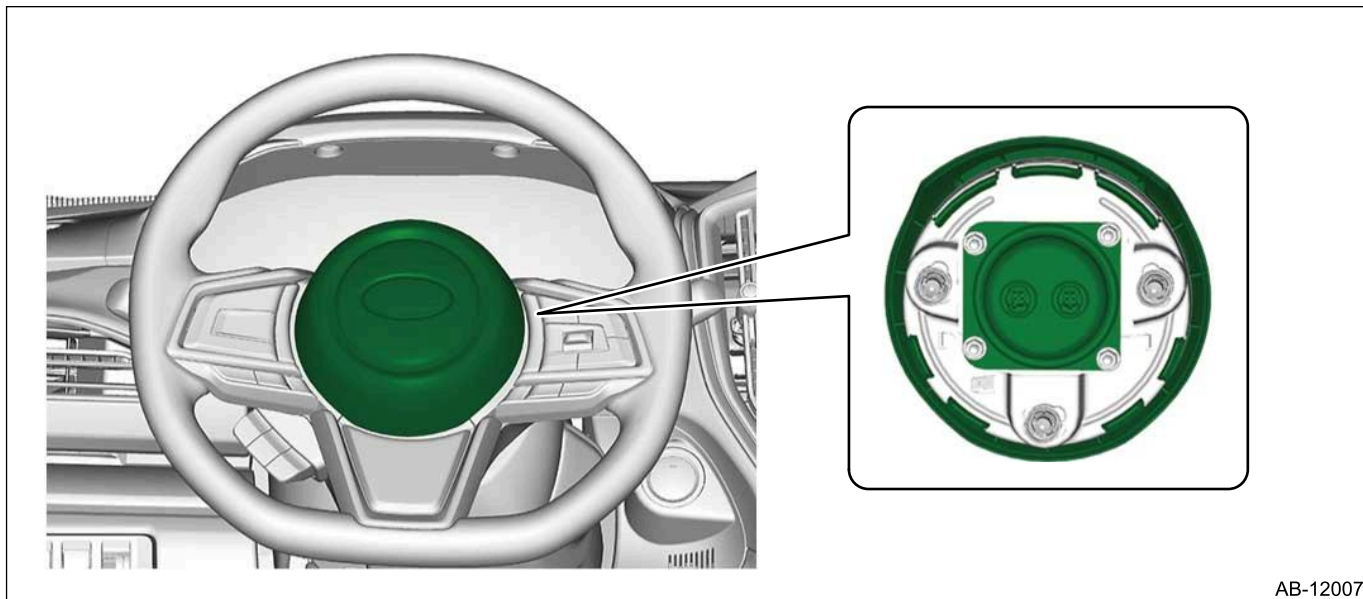

AB-12007

**2. KNEE AIRBAG MODULE**

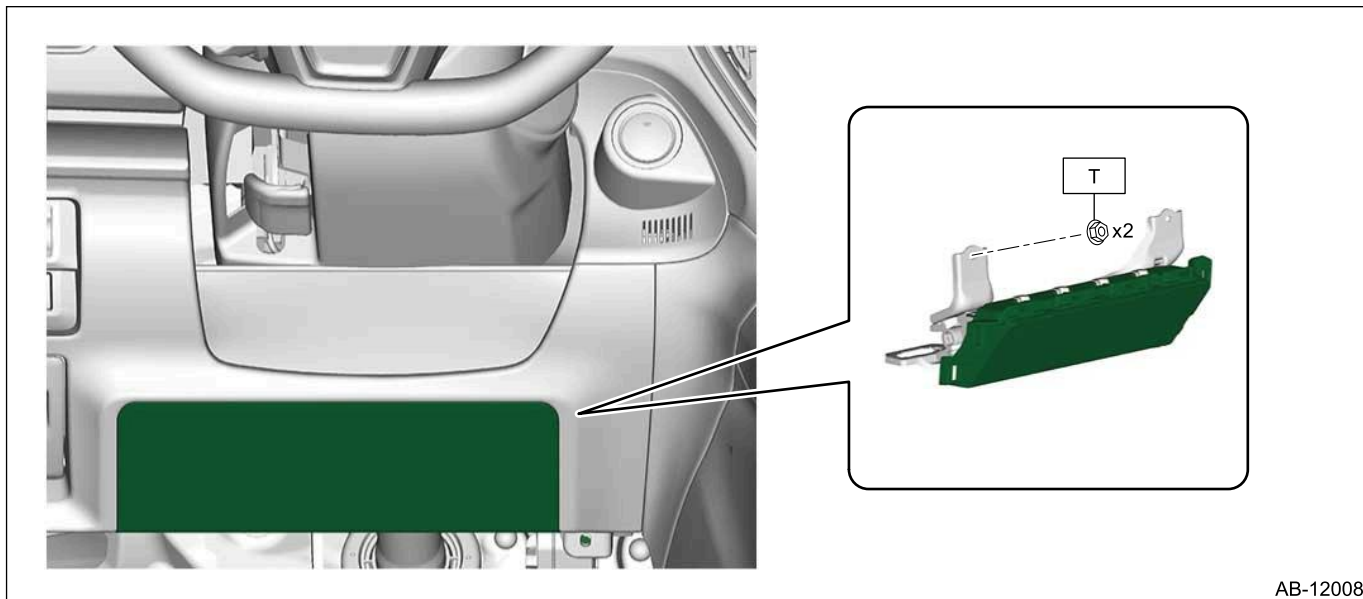

AB-12008

**Tightening torque: N-m (kgf-m, ft-lb)**

**T: 7.5 (0.8, 5.5)**

### 3. PASSENGER'S AIRBAG MODULE

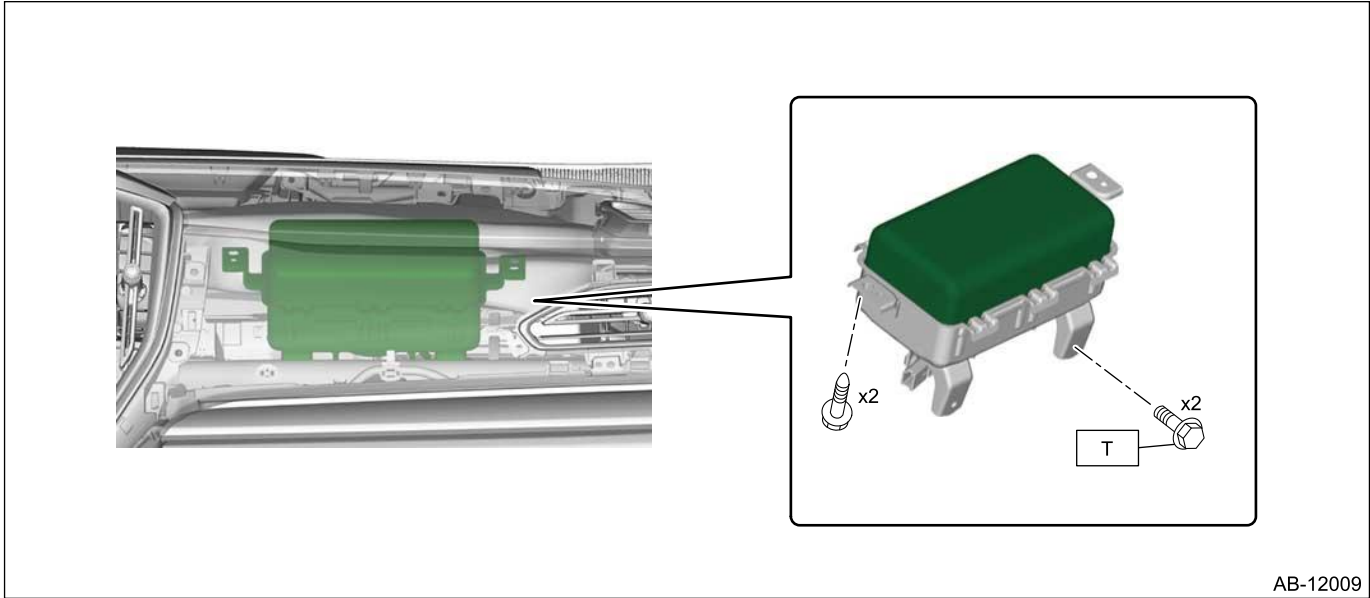

**Tightening torque: N-m (kgf-m, ft-lb)**

**T: 7.5 (0.8, 5.5)**

### 4. SIDE AIRBAG MODULE

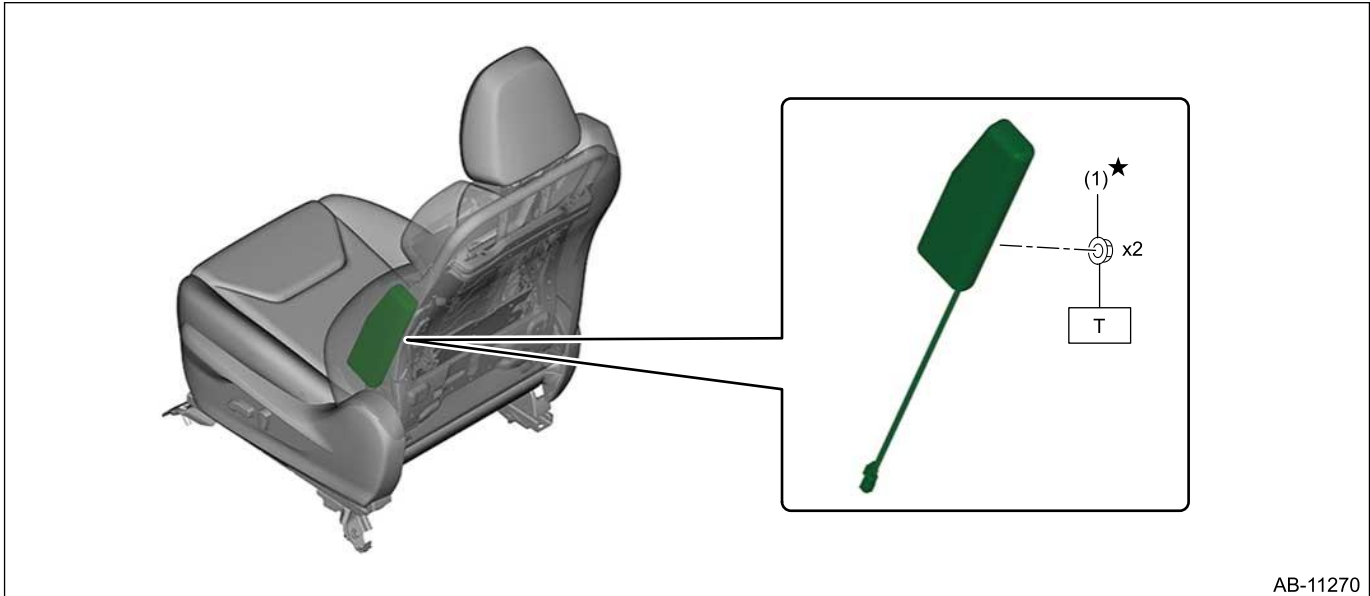

(1) Self-locking nut

**Tightening torque: N-m (kgf-m, ft-lb)**

**T: 6 (0.6, 4.4)**

## 5. CURTAIN AIRBAG MODULE

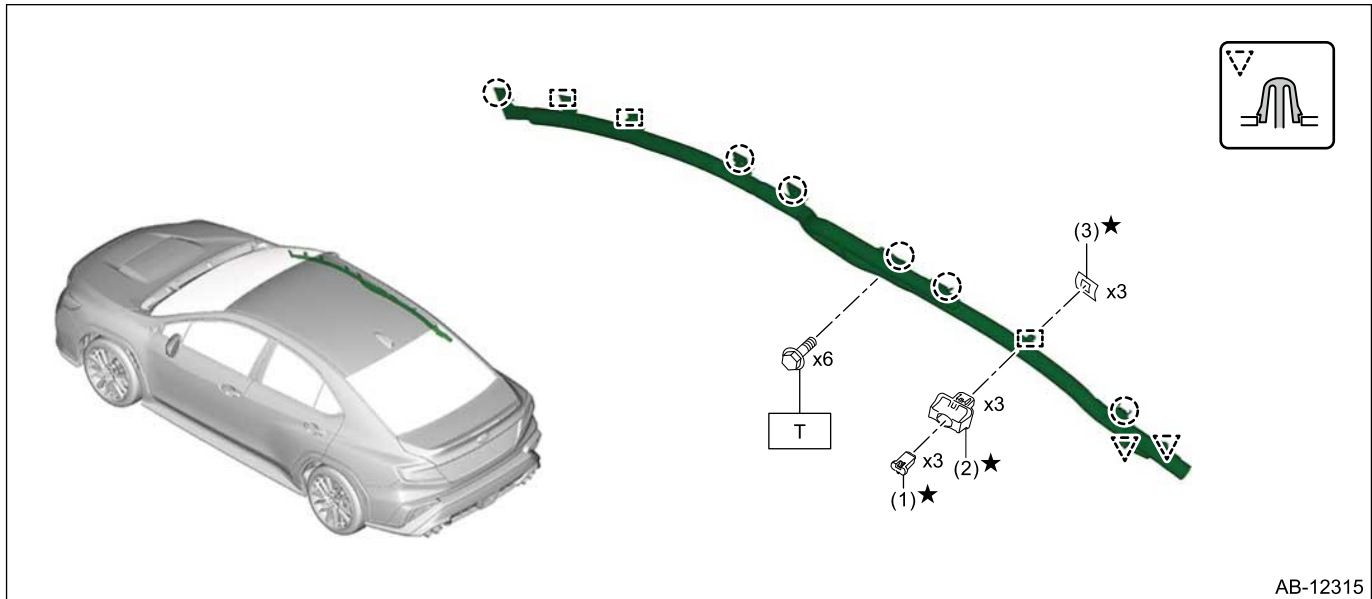

(1) Clip pin

(3) Spacer

**Tightening torque: N-m (kgf-m, ft-lb)**

(2) Clip bushing

**T: 7.5 (0.8, 5.5)**

## 6. AIRBAG CONTROL MODULE

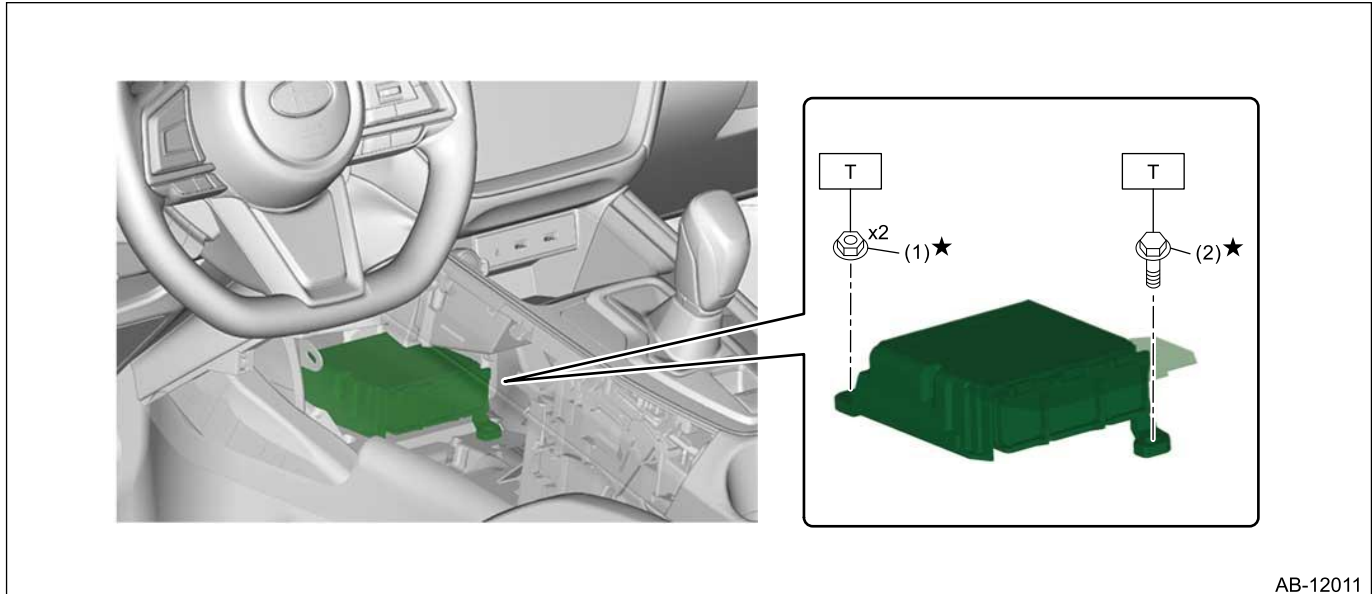

(1) Nut

(2) Flange bolt

**Tightening torque: N-m (kgf-m, ft-lb)**

**T: 25 (2.5, 18.4)**

## 7. Front impact sensor

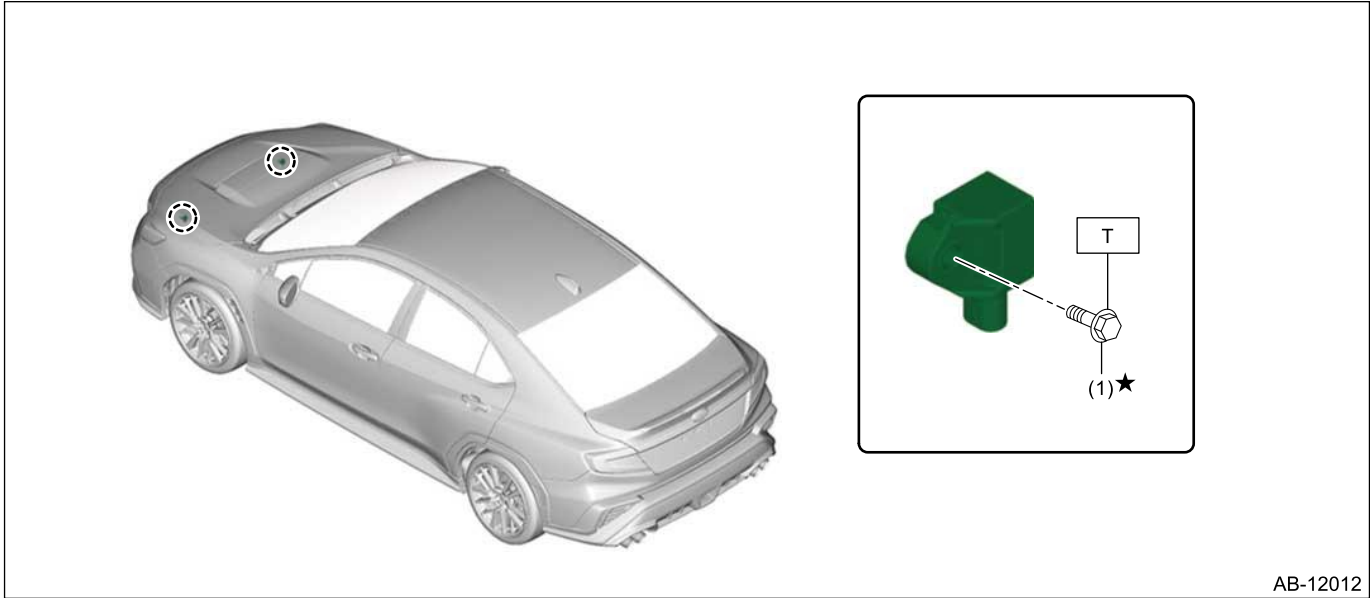

AB-12012

(1) Flange bolt

**Tightening torque: N-m (kgf-m, ft-lb)**

**T: 13 (1.3, 9.6)**

## 8. Side impact sensor (front door)

### Caution:

- The nuts cannot be removed from Side impact sensor (front door) . Do not remove the mounting nuts.
- Do not reuse Side impact sensor (front door) that have been removed.

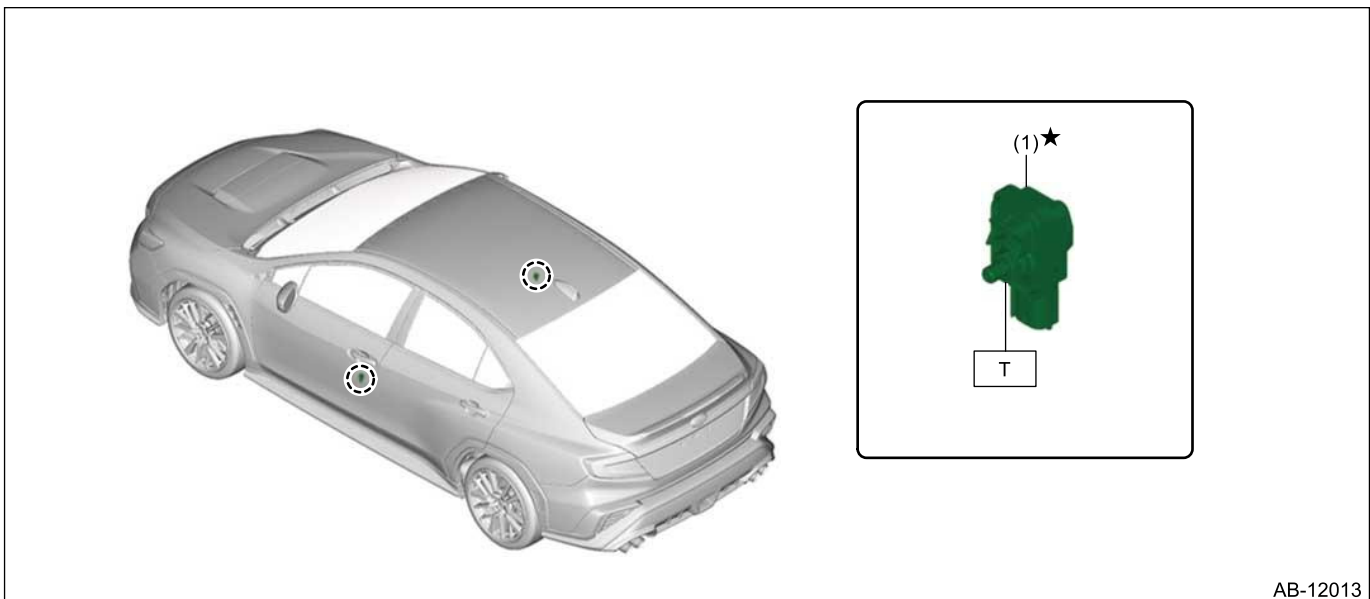

AB-12013

(1) Side impact sensor (front door)

**Tightening torque: N-m (kgf-m, ft-lb)**

**T: 7.5 (0.8, 5.5)**

## 9. Side impact sensor (center pillar)

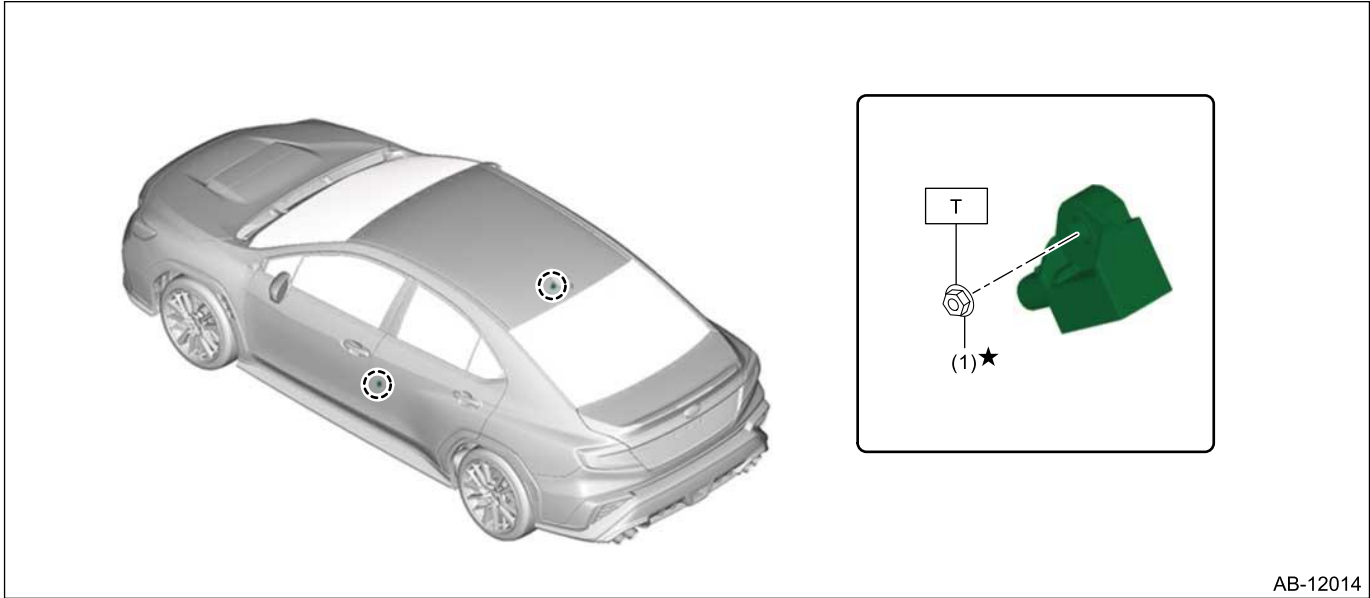

AB-12014

(1) Nut

**Tightening torque: N-m (kgf-m, ft-lb)**

**T: 7.5 (0.8, 5.5)**

## 10. Side impact sensor (rear wheel house)

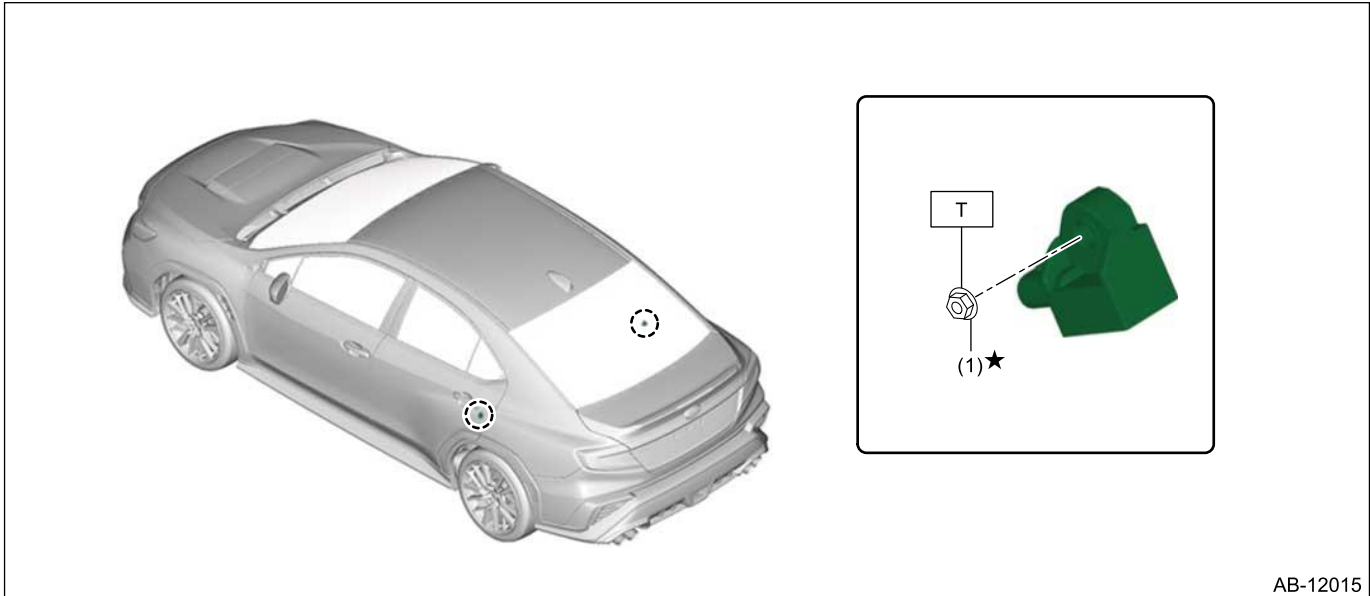

AB-12015

(1) Nut

**Tightening torque: N-m (kgf-m, ft-lb)**

**T: 7.5 (0.8, 5.5)**

## 11. Side impact sensor (under the rear center seat)

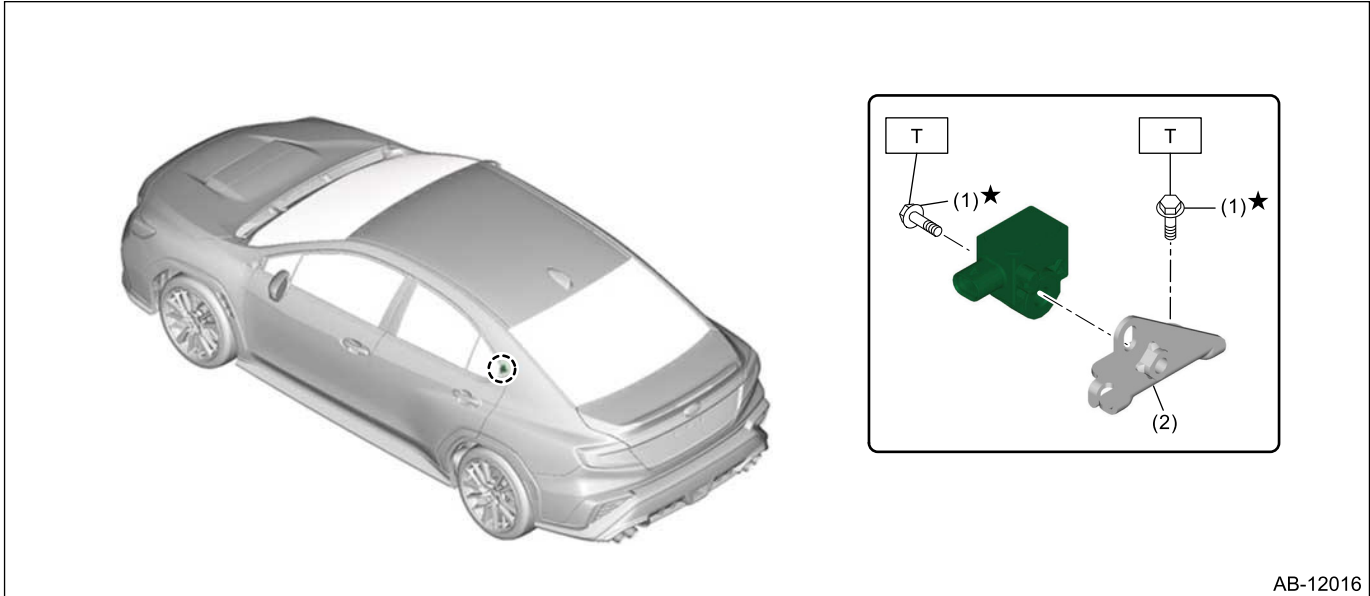

AB-12016

(1) Flange bolt

(2) Bracket sensor

**Tightening torque: N-m (kgf-m, ft-lb)**

***T: 7.5 (0.8, 5.5)***

## 12. STEERING ROLL CONNECTOR

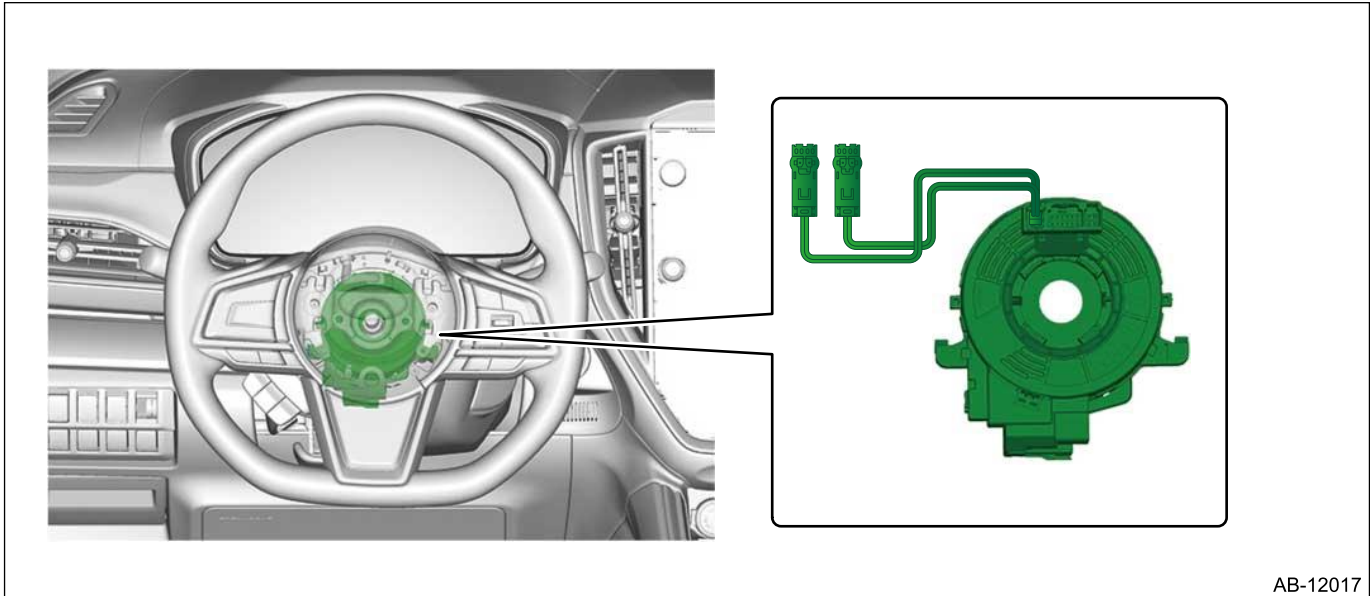

AB-12017

## 13. SEAT BELT PRETENSIONER

For the components of the seat belt pretensioner, refer to the "SEAT BELT SYSTEM" section.  [Ref. to SEAT BELT SYSTEM>General Description>COMPONENT.](#)

AIRBAG SYSTEM > General Description

**INSPECTION**

## 1. BASIC INSPECTION

For basic inspection, refer to "Basic Diagnostic Procedure" of "AIRBAG (DIAGNOSTICS)" section.  [Ref. to AIRBAG\(DIAGNOSTICS\)>Basic Diagnostic Procedure.](#)

## 2. SYSTEM BLOCK DIAGRAM

For system block diagram, refer to "System Block Diagram" in "AIRBAG (DIAGNOSTICS)" section.  [Ref. to AIRBAG\(DIAGNOSTICS\)>General Description>SYSTEM BLOCK DIAGRAM.](#)

## 3. MODULE I/O SIGNAL

For the specification (electrical component), refer to "Control Module I/O Signal" of "AIRBAG (DIAGNOSTICS)" section.  [Ref. to AIRBAG\(DIAGNOSTICS\)>Control Module I/O Signal.](#)

### AIRBAG SYSTEM > General Description

#### PREPARATION TOOL

---

#### 1. SUBARU SPECIAL TOOL

ILLUSTRATION	TOOL NUMBER	DESCRIPTION	REMARKS
 STSSM4	—	SUBARU SELECT MONITOR 4	Used for setting of each function and troubleshooting for electrical system. <b>Note:</b> <ul style="list-style-type: none"><li>• For detailed operation procedures, refer to "Help" of application.</li><li>• Used together with interface for Subaru Select Monitor (such as DST-i and DST-010).</li></ul>
 ST98299SA000	98299SA000	TEST HARNESS N	Used for unit inspection of steering roll connector.

ILLUSTRATION	TOOL NUMBER	DESCRIPTION	REMARKS
 <p data-bbox="305 512 441 533">ST98299SA040</p>	98299SA040	TEST HARNESS Q	Used for unit inspection of steering roll connector.
 <p data-bbox="305 890 441 911">ST98299SA010</p>	98299SA010	TEST HARNESS ADAPTER D	<ul style="list-style-type: none"> <li>• Used for operation process of driver's airbag module.</li> <li>• Used for operation process of knee airbag module.</li> <li>• Used for operation process of curtain airbag module.</li> <li>• Used together with AIRBAG DEPLOYMENT TOOL. (98299PA030)</li> </ul>
 <p data-bbox="305 1268 441 1289">ST98299FJ000</p>	98299FJ000	TEST HARNESS ADAPTER AM	<ul style="list-style-type: none"> <li>• Used for operation process of passenger's airbag module.</li> <li>• Used together with AIRBAG DEPLOYMENT TOOL. (98299PA030)</li> </ul>
 <p data-bbox="305 1646 441 1667">ST98299AL000</p>	98299AL000	TEST HARNESS ADAPTER AU	<ul style="list-style-type: none"> <li>• Used for operation process of seat cushion airbag module.</li> <li>• Used together with AIRBAG DEPLOYMENT TOOL. (98299PA030)</li> </ul>

ILLUSTRATION	TOOL NUMBER	DESCRIPTION	REMARKS
 <p data-bbox="305 512 444 533">ST98299CA000</p>	98299CA000	TEST HARNESS ADAPTER AR	<ul style="list-style-type: none"> <li>• Used for operation process of side airbag module.</li> <li>• Used together with AIRBAG DEPLOYMENT TOOL. (98299PA030)</li> </ul>
 <p data-bbox="305 886 444 907">ST98299PA030</p>	98299PA030	AIRBAG DEPLOYMENT TOOL	<ul style="list-style-type: none"> <li>• Used for operation process of airbag module.</li> <li>• Used together with each test harness adapter.</li> </ul>

## 2. OTHER

	REMARKS
Steering wheel puller	Used for removing the steering wheel assembly.
Circuit tester	Used for measuring resistance, voltage and current.

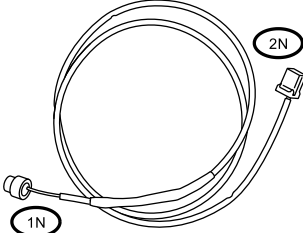
## PROCEDURE

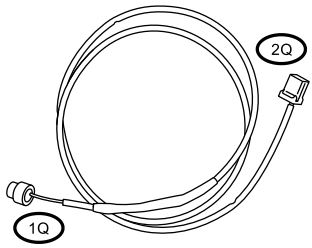
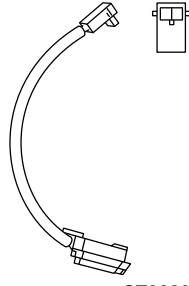
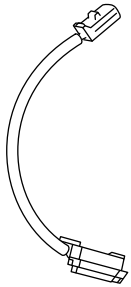
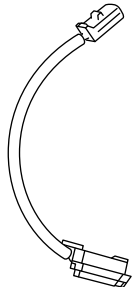
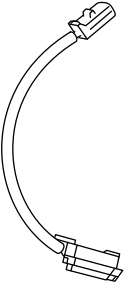
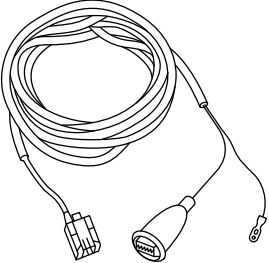
### 1. AIRBAG CONTROL MODULE

#### 1. How to disconnect:

- (1) Push the lock lever plate (a).
- (2) While holding down the lock lever plate (a), pull the lever (b) toward you.
- (3) Pull out the connector.

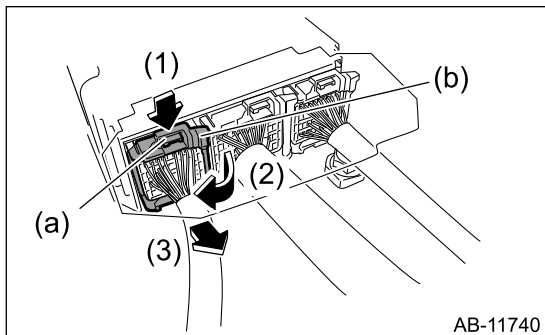

#### 2. How to connect:

**Note:**

**Be sure to insert the connector in until it is locked. Then pull it gently to make sure that it is locked.**

Insert the connector and push the lock lever in securely.

### 2. STEERING ROLL CONNECTOR

#### 1. How to disconnect:

**Note:**

**When pulling the slide lock or disconnecting the connector, be sure to hold the connector, not the harness, to disconnect.**

- (1) Pull the slide lock (a) in the direction of arrow.
- (2) With the slide lock (a) pulled, disconnect the connector.

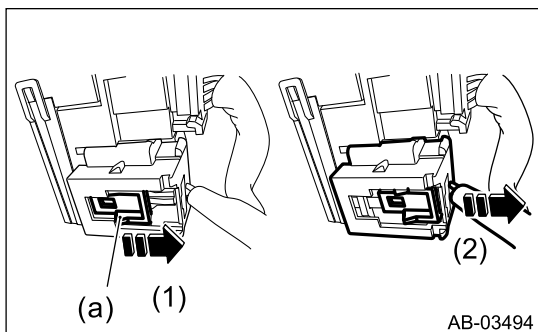

#### 2. How to connect:

**Note:**

**Be sure to insert the connector in until it is locked. Then pull it gently to make sure that it is locked.**

Holding the connector, push it in securely until a clicking sound is heard.

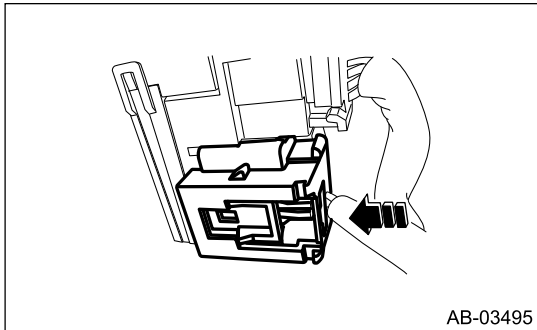

### 3. PASSENGER'S AIRBAG MODULE, REAR SEAT BELT PRETENSIONER, FRONT SEAT BELT PRETENSIONER & ADAPTIVE FORCE LIMITER

#### 1. How to disconnect:

**Note:**

**When pulling the slide lock or disconnecting the connector, be sure to hold the connector, not the harness, to disconnect.**

- (1) Pull the slide lock (a) in the direction of arrow.
- (2) With the slide lock (a) pulled, disconnect the connector.

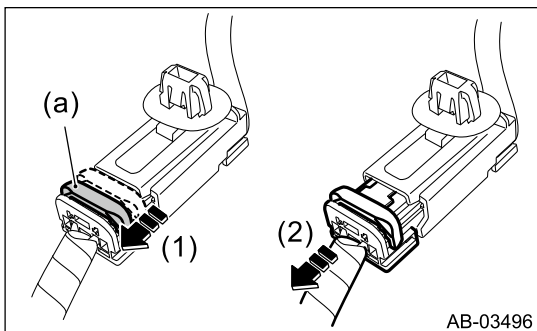

#### 2. How to connect:

**Note:**

**Be sure to insert the connector in until it is locked. Then pull it gently to make sure that it is locked.**

Holding the connector, push it in securely until a clicking sound is heard.

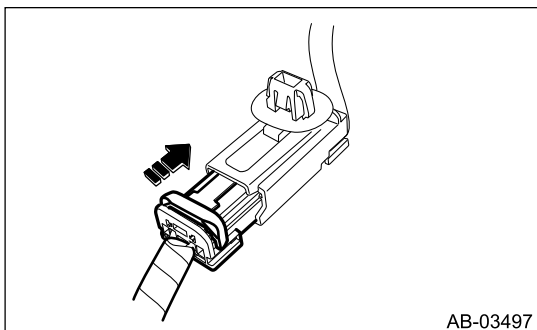

### 4. CURTAIN AIRBAG MODULE

#### 1. How to disconnect:

- (1) Using a flat tip screwdriver wrapped with a protective tape, pry the push lock upward to unlock.

(2) Pull the connector to disconnect from the airbag module assembly or the retractor assembly.

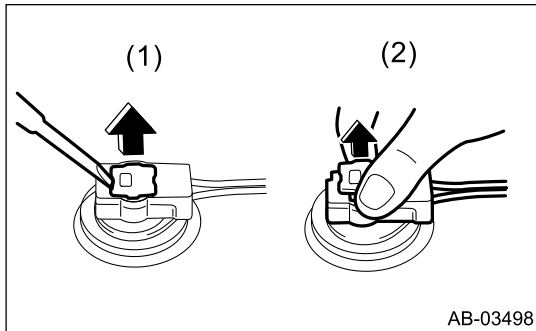

**2.** How to connect:

**Note:**

- **Be sure to insert the connector in until it is locked.**
- **Press in the push lock securely. Then pull it gently to make sure that it is locked.**

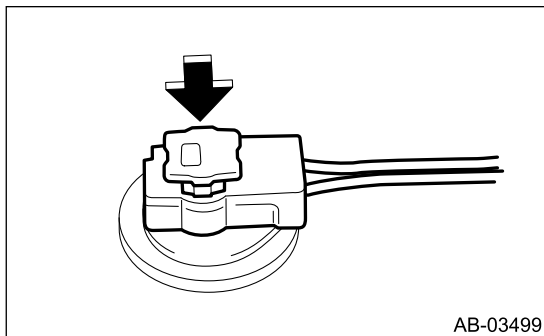

Connect the connector in the reverse order of disconnecting. At this time, be sure to insert until a clicking sound is heard.

## 5. EACH IMPACT SENSOR

**Note:**

**The sensor shapes vary depending on the locations.**

**1.** How to disconnect:

**Note:**

**When pulling the slide lock or disconnecting the connector, be sure to hold the connector, not the harness, to disconnect.**

- (1) Pull the lock arm (a) one step in the direction of arrow while pushing.
- (2) While pressing down the lock arm (a), hold the outer part of connector to disconnect the connector.

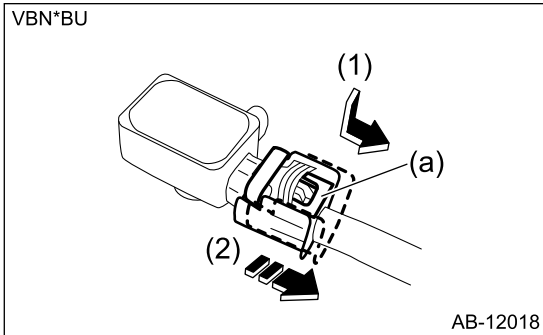

**2.** How to connect:

**Note:**

**Be sure to insert the connector in until it is locked. Then pull it gently to make sure that it is locked.**

Insert the connector, and push the lock arm securely until a clicking sound is heard.

**6. Side impact sensor (front door)**

**1.** How to disconnect:

**Note:**

**When pulling the slide lock or disconnecting the connector, be sure to hold the connector, not the harness, to disconnect.**

- (1) Pull the lock arm (a) one step in the direction of arrow while pushing.
- (2) Push the lock arm (a) again.
- (3) Holding outer part, pull it in the direction of arrow to disconnect the connector.

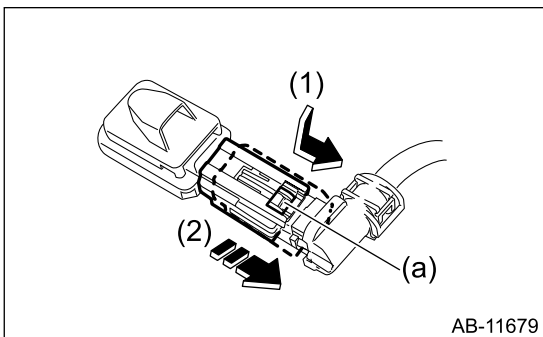

**2.** How to connect:

**Note:**

**Be sure to insert the connector in until it is locked. Then pull it gently to make sure that it is locked.**

Holding the connector, push it in securely until a clicking sound is heard.

**7. SIDE AIRBAG MODULE**

**1.** How to disconnect:

**Note:**

**When pulling the slide lock or disconnecting the connector, be sure to hold the connector, not the harness, to disconnect.**

- (1) Pull the lock arm (a) one step while pushing.
- (2) Holding outer part, pull it one step in the direction of arrow.

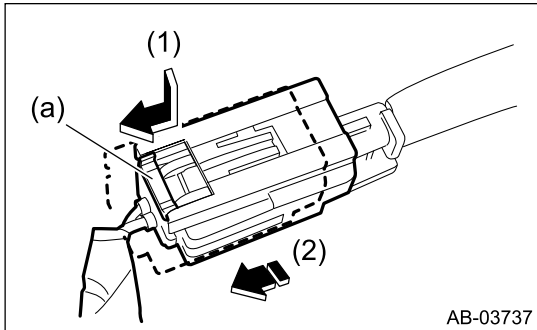

(3) Push the lock arm again.

(4) Holding outer part, pull it in the direction of arrow to disconnect the connector.

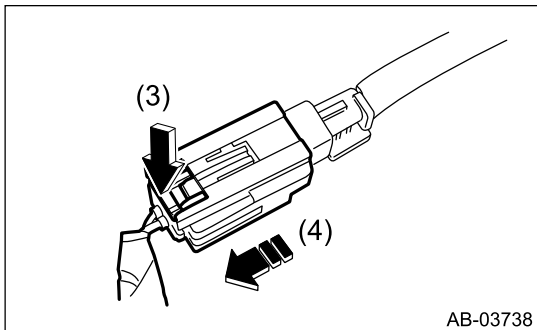

## 2. How to connect:

### Note:

**Be sure to insert the connector in until it is locked. Then pull it gently to make sure that it is locked.**

Holding the connector, push it in securely until a clicking sound is heard.

## 8. BUCKLE SWITCH RH

### 1. How to disconnect:

### Note:

**When pulling the slide lock or disconnecting the connector, be sure to hold the connector, not the harness, to disconnect.**

(1) Move the slide lock (A) in the direction of arrow and hold it.

(2) While holding the slide lock (A), pull the connector (B) in the direction of arrow.

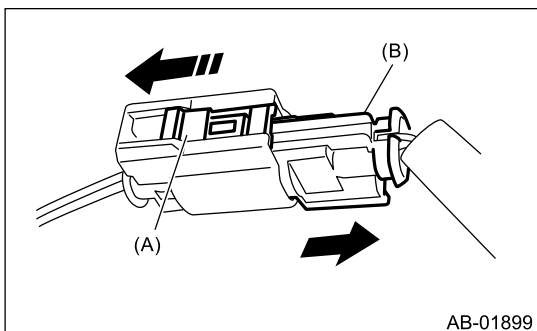

### 2. How to connect:

**Note:**

**Be sure to insert the connector in until it is locked. Then pull it gently to make sure that it is locked.**

Holding the connector, push it in securely until a clicking sound is heard.

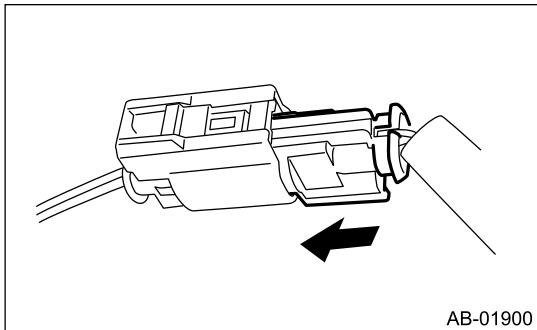

## 9. KNEE AIRBAG MODULE, DRIVER'S AIRBAG MODULE & LAP SEAT BELT PRETENSIONER

### 1. How to disconnect:

- (1) Using a flat tip screwdriver wrapped with a protective tape, pry the push lock upward to unlock.
- (2) Pull the connector to disconnect from the airbag module assembly.

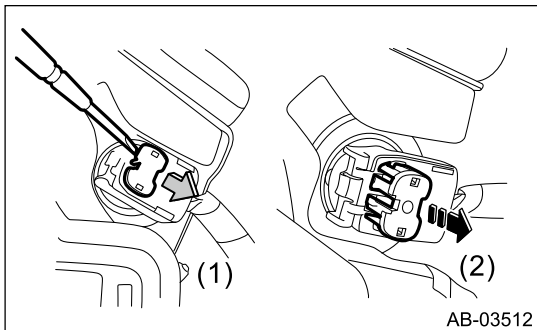

### 2. How to connect:

**Note:**

- **Be sure to insert the connector in until it is locked.**
- **Press in the push lock securely. Then pull it gently to make sure that it is locked.**

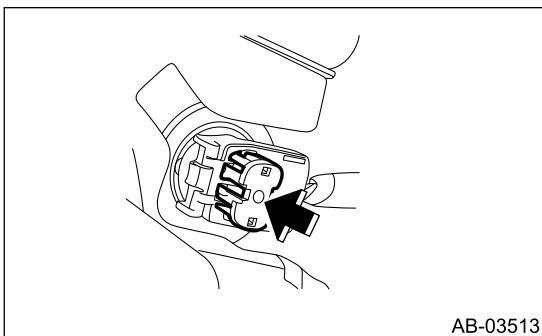

Connect the connector in the reverse order of disconnecting. At this time, be sure to insert until a clicking sound is heard.

## AIRBAG SYSTEM > Inspection Locations after a Collision

### INSPECTION

---

If the vehicle is involved in a collision, even if it is a slight collision, be sure to check the following systems.

#### 1. DRIVER'S AIRBAG MODULE ASSEMBLY

##### 1. Vehicle frontal collision (driver's airbag module assembly activated)

###### 1. Replace the following parts with new ones.

- Airbag control module
- Driver's airbag module
- Knee airbag module
- Passenger's airbag module (if deployed)
- Seat assembly (if any of the airbag modules below deployed)
  - Side airbag module
- Curtain airbag module (right and left / if deployed)
- Belt assembly front OUT (LH and RH)
  - Front seat belt pretensioner
  - Lap seat belt pretensioner (passenger's seat)
  - Locking tongue (front seat)
- Adjuster shoulder anchor
- Belt assembly rear OUT (right and left outer side)
  - Rear seat belt pretensioner
  - Locking tongue (rear seat)
- Front impact sensor (LH and RH)
- Instrument panel assembly (if passenger's airbag module deployed)
- Steering wheel assembly
- Column assembly steering
- Steering roll connector
- Passenger's seat occupant detection system (Perform the inspection following the diagnostic procedure in the "AIRBAG (DIAGNOSTICS)" section.)  [Ref. to AIRBAG\(DIAGNOSTICS\)>Basic Diagnostic Procedure>PROCEDURE.](#)

###### 2. Visually inspect the following items and replace any damaged part with a new one.

- Passenger's airbag module (if not deployed)
- Instrument panel assembly (if passenger's airbag module not deployed)
- Universal joint assembly steering
- Steering gearbox assembly
- Beam steering COMPL
- Belt assembly front INN
- Belt assembly rear INN
- Belt assembly rear OUT CTR
- Harnesses and connectors on body side that are linked to the replaced parts

##### 2. Vehicle frontal collision (driver's airbag module not activated)

Visually inspect the following items and replace any damaged or cracked part with a new one.

Specially inspect the damage of airbag module body, mounting bracket and harness connector.

- Driver's airbag module

- Knee airbag module
- Passenger's airbag module
- Belt assembly front OUT (LH and RH)
  - Front seat belt pretensioner
  - Lap seat belt pretensioner (passenger's seat)
  - Locking tongue (front seat)
- Adjuster shoulder anchor
- Belt assembly rear OUT (right and left outer side)
  - Rear seat belt pretensioner
  - Locking tongue (rear seat)
- Front impact sensor (LH and RH)
- Instrument panel assembly
- Passenger's seat occupant detection system (Perform the inspection following the diagnostic procedure in the "AIRBAG (DIAGNOSTICS)" section.)  [Ref. to AIRBAG\(DIAGNOSTICS\)>Basic Diagnostic Procedure>PROCEDURE.](#)



### 3. No frontal collision

- Visually inspect the airbag modules for damage or contamination and replace any faulty part with a new one.
- Passenger's seat occupant detection system (Perform the inspection following the diagnostic procedure in the "AIRBAG (DIAGNOSTICS)" section.)  [Ref. to AIRBAG\(DIAGNOSTICS\)>Basic Diagnostic Procedure>PROCEDURE.](#)

## 2. KNEE AIRBAG MODULE

### 1. Vehicle frontal collision (knee airbag module activated)

1. Replace the following parts with new ones.
  - Airbag control module
  - Driver's airbag module
  - Knee airbag module
  - Passenger's airbag module (if deployed)
  - Seat assembly (if any of the airbag modules below deployed)
    - Side airbag module
  - Curtain airbag module (right and left / if deployed)
  - Belt assembly front OUT (LH and RH)
    - Front seat belt pretensioner
    - Lap seat belt pretensioner (passenger's seat)
    - Locking tongue (front seat)
  - Adjuster shoulder anchor
  - Belt assembly rear OUT (right and left outer side)
    - Rear seat belt pretensioner
    - Locking tongue (rear seat)
  - Front impact sensor (LH and RH)
  - Instrument panel assembly (if passenger's airbag module deployed)
  - Steering wheel assembly
  - Column assembly steering
  - Steering roll connector

- Passenger's seat occupant detection system (Perform the inspection following the diagnostic procedure in the "AIRBAG (DIAGNOSTICS)" section.)  [Ref. to AIRBAG\(DIAGNOSTICS\)>Basic Diagnostic Procedure>PROCEDURE.](#)
2. Visually inspect the following items and replace any damaged part with a new one.
- Passenger's airbag module (if not deployed)
  - Instrument panel assembly (if passenger's airbag module not deployed)
  - Universal joint assembly steering
  - Steering gearbox assembly
  - Beam steering COMPL
  - Belt assembly front INN
  - Belt assembly rear INN
  - Belt assembly rear OUT CTR
  - Harnesses and connectors on body side that are linked to the replaced parts
- 2.** Vehicle frontal collision (knee airbag module not activated)
- Visually inspect the following items and replace any damaged or cracked part with a new one. Specially inspect the damage of airbag module body, mounting bracket and harness connector.
- Driver's airbag module
  - Knee airbag module
  - Passenger's airbag module
  - Belt assembly front OUT (LH and RH)
    - Front seat belt pretensioner
    - Lap seat belt pretensioner (passenger's seat)
    - Locking tongue (front seat)
  - Adjuster shoulder anchor
  - Belt assembly rear OUT (right and left outer side)
    - Rear seat belt pretensioner
    - Locking tongue (rear seat)
  - Front impact sensor (LH and RH)
  - Instrument panel assembly
  - Passenger's seat occupant detection system (Perform the inspection following the diagnostic procedure in the "AIRBAG (DIAGNOSTICS)" section.)  [Ref. to AIRBAG\(DIAGNOSTICS\)>Basic Diagnostic Procedure>PROCEDURE.](#)
- 3.** No frontal collision
- Visually inspect the airbag modules for damage or contamination and replace any faulty part with a new one.
  - Passenger's seat occupant detection system (Perform the inspection following the diagnostic procedure in the "AIRBAG (DIAGNOSTICS)" section.)  [Ref. to AIRBAG\(DIAGNOSTICS\)>Basic Diagnostic Procedure>PROCEDURE.](#)

### **3. PASSENGER'S AIRBAG MODULE**

- 1.** Vehicle frontal collision (passenger's airbag module activated)
1. Replace the following parts with new ones.
- Airbag control module
  - Driver's airbag module
  - Knee airbag module
  - Passenger's airbag module

- Seat assembly (if any of the airbag modules below deployed)
  - Side airbag module
- Curtain airbag module (right and left / if deployed)
- Belt assembly front OUT (LH and RH)
  - Front seat belt pretensioner
  - Lap seat belt pretensioner (passenger's seat)
  - Locking tongue (front seat)
- Adjuster shoulder anchor
- Belt assembly rear OUT (right and left outer side)
  - Rear seat belt pretensioner
  - Locking tongue (rear seat)
- Front impact sensor (LH and RH)
- Instrument panel assembly
- Steering wheel assembly
- Column assembly steering
- Steering roll connector
- Passenger's seat occupant detection system (Perform the inspection following the diagnostic procedure in the "AIRBAG (DIAGNOSTICS)" section.)  [Ref. to AIRBAG\(DIAGNOSTICS\)>Basic Diagnostic Procedure>PROCEDURE.](#)

2. Visually inspect the following items and replace any damaged part with a new one.

- Universal joint assembly steering
- Steering gearbox assembly
- Beam steering COMPL
- Belt assembly front INN
- Belt assembly rear INN
- Belt assembly rear OUT CTR
- Harnesses and connectors on body side that are linked to the replaced parts

**2.** Vehicle frontal collision (passenger's airbag module not activated)

Visually inspect the following items and replace any damaged or cracked part with a new one.

Specially inspect the damage of airbag module body, mounting bracket and harness connector.

- Driver's airbag module
- Knee airbag module
- Passenger's airbag module
- Belt assembly front OUT (LH and RH)
  - Front seat belt pretensioner
  - Lap seat belt pretensioner (passenger's seat)
  - Locking tongue (front seat)
- Adjuster shoulder anchor
- Belt assembly rear OUT (right and left outer side)
  - Rear seat belt pretensioner
  - Locking tongue (rear seat)
- Front impact sensor (LH and RH)
- Instrument panel assembly
- Passenger's seat occupant detection system (Perform the inspection following the diagnostic procedure in the "AIRBAG (DIAGNOSTICS)" section.)  [Ref. to AIRBAG\(DIAGNOSTICS\)>Basic Diagnostic Procedure>PROCEDURE.](#)

### 3. No frontal collision

- Visually inspect the airbag modules for damage or contamination and replace any faulty part with a new one.
- Passenger's seat occupant detection system (Perform the inspection following the diagnostic procedure in the "AIRBAG (DIAGNOSTICS)" section.)  [Ref. to AIRBAG\(DIAGNOSTICS\)>Basic Diagnostic Procedure>PROCEDURE.](#)

## 4. SIDE AIRBAG MODULE

### 1. Vehicle side impact (side airbag module activated)

#### 1. Replace the following parts with new ones.

- Airbag control module
- Side impact sensor (under the rear center seat)
- Plate sensor cover Side impact sensor (under the rear center seat)
- Side impact sensor (front door) (collision side)
- Pad front door inner (collision side)
- Belt assembly front OUT (LH and RH)
  - Front seat belt pretensioner
  - Lap seat belt pretensioner (passenger's seat)
  - Locking tongue (front seat)
- Adjuster shoulder anchor
- Belt assembly rear OUT (right and left outer side)
  - Rear seat belt pretensioner
  - Locking tongue (rear seat)
- Side impact sensor (center pillar) (collision side)
- Curtain airbag module (collision side)
- Side impact sensor (rear wheel house) (collision side)
- Seat assembly (collision side)
  - Side airbag module
- Trim panel roof assembly
- Trim panel for each pillar (collision side)
- Passenger's seat occupant detection system (Perform the inspection following the diagnostic procedure in the "AIRBAG (DIAGNOSTICS)" section.)  [Ref. to AIRBAG\(DIAGNOSTICS\)>Basic Diagnostic Procedure>PROCEDURE.](#)

#### 2. Visually inspect the following items and replace any damaged part (collision side) with a new one.

- Harnesses and connectors on body side that are linked to the replaced parts

### 2. Vehicle side impact (side airbag module not activated)

Visually inspect the following items and replace any damaged or cracked part (collision side) with a new one.

Specially inspect the damage of airbag module body, mounting bracket and harness connector.

- Seat assembly
  - Side airbag module
- Side impact sensor (under the rear center seat)
- Plate sensor cover Side impact sensor (under the rear center seat)
- Side impact sensor (front door)
- Pad front door inner
- Side airbag module

- Side impact sensor (center pillar)
- Curtain airbag module
- Side impact sensor (rear wheel house)
- Belt assembly front OUT (LH and RH)
  - Front seat belt pretensioner
  - Lap seat belt pretensioner (passenger’s seat)
  - Locking tongue (front seat)
- Adjuster shoulder anchor
- Belt assembly rear OUT (right and left outer side)
  - Rear seat belt pretensioner
  - Locking tongue (rear seat)
- Passenger’s seat occupant detection system (Perform the inspection following the diagnostic procedure in the “AIRBAG (DIAGNOSTICS)” section.)  [Ref. to AIRBAG\(DIAGNOSTICS\)>Basic Diagnostic Procedure>PROCEDURE.](#)

**3.** No side impact

- Visually inspect the airbag modules for damage or contamination and replace any faulty part with a new one.
- Passenger’s seat occupant detection system (Perform the inspection following the diagnostic procedure in the “AIRBAG (DIAGNOSTICS)” section.)  [Ref. to AIRBAG\(DIAGNOSTICS\)>Basic Diagnostic Procedure>PROCEDURE.](#)

**5. CURTAIN AIRBAG MODULE**

**1.** Vehicle side impact or roll over (curtain airbag module activated)

1. Replace the following parts with new ones.

- Airbag control module
- Side impact sensor (under the rear center seat)
- Plate sensor cover Side impact sensor (under the rear center seat)
- Side impact sensor (front door) (collision side)
- Pad front door inner (collision side)
- Belt assembly front OUT (LH and RH)
  - Front seat belt pretensioner
  - Lap seat belt pretensioner (passenger’s seat)
  - Locking tongue (front seat)
- Adjuster shoulder anchor
- Belt assembly rear OUT (right and left outer side)
  - Rear seat belt pretensioner
  - Locking tongue (rear seat)
- Side impact sensor (center pillar) (collision side)
- Curtain airbag module (collision side)
- Side impact sensor (rear wheel house) (collision side)
- Seat assembly (collision side)
  - Side airbag module
- Trim panel roof assembly
- Trim panel for each pillar (collision side)
- Passenger’s seat occupant detection system (Perform the inspection following the diagnostic procedure in the “AIRBAG (DIAGNOSTICS)” section.)  [Ref. to AIRBAG\(DIAGNOSTICS\)>Basic](#)

### [Diagnostic Procedure>PROCEDURE.](#)

2. Visually inspect the following items and replace any damaged part (collision side) with a new one.

- Harnesses and connectors on body side that are linked to the replaced parts

### **2.** Vehicle side impact or roll over (curtain airbag module not activated)

Visually inspect the following items and replace any damaged or cracked part (collision side) with a new one.

Specially inspect the damage of airbag module body, mounting bracket and harness connector.

- Trim panel roof assembly
- Trim panel for each pillar
- Curtain airbag module
- Side impact sensor (under the rear center seat)
- Plate sensor cover Side impact sensor (under the rear center seat)
- Side impact sensor (front door)
- Pad front door inner
- Side impact sensor (center pillar)
- Side impact sensor (rear wheel house)
- Belt assembly front OUT (LH and RH)
  - Front seat belt pretensioner
  - Lap seat belt pretensioner (passenger's seat)
  - Locking tongue (front seat)
- Adjuster shoulder anchor
- Belt assembly rear OUT (right and left outer side)
  - Rear seat belt pretensioner
  - Locking tongue (rear seat)
- Passenger's seat occupant detection system (Perform the inspection following the diagnostic procedure in the "AIRBAG (DIAGNOSTICS)" section.)  [Ref. to AIRBAG\(DIAGNOSTICS\)>Basic Diagnostic Procedure>PROCEDURE.](#)

### **3.** No side impact

- Visually inspect the airbag modules for damage or contamination and replace any faulty part with a new one.
- Passenger's seat occupant detection system (Perform the inspection following the diagnostic procedure in the "AIRBAG (DIAGNOSTICS)" section.)  [Ref. to AIRBAG\(DIAGNOSTICS\)>Basic Diagnostic Procedure>PROCEDURE.](#)

## **6. AIRBAG CONTROL MODULE**

Check for the following, and replace the damaged parts with new parts.

- Control module is cracked or deformed.
- Connector is scratched, cracked or deformed.
- Driver's airbag module has been activated.
- Knee airbag module has been activated.
- Passenger's airbag module has been activated.
- Side airbag module has been activated.
- Curtain airbag module has been activated.
- Front seat belt pretensioner has been activated.
- Lap seat belt pretensioner has been activated.
- Rear seat belt pretensioner has been activated.

## 7. FRONT IMPACT SENSOR

If the section of vehicle as shown in the figure is damaged, check the following items and replace the damaged parts with new parts.

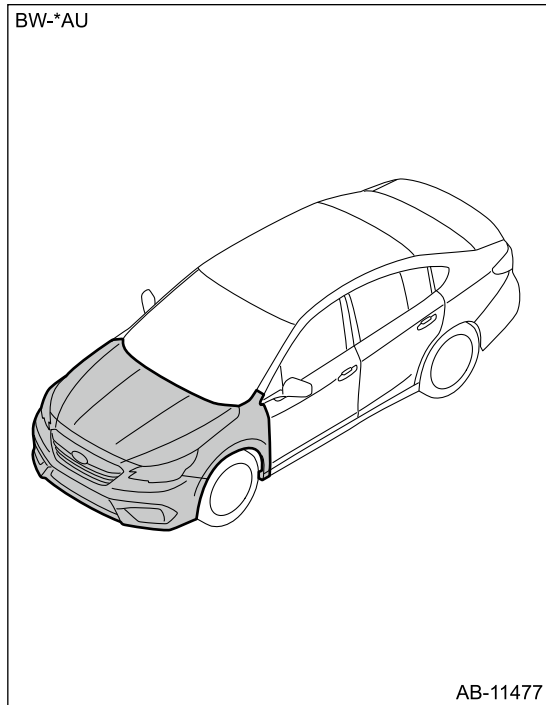

- Front impact sensor is cracked or deformed.
- Connector is scratched, cracked or deformed.

## 8. EACH SIDE IMPACT SENSOR

If the section of vehicle as shown in the figure is damaged, check the following items and replace the damaged parts with new parts.

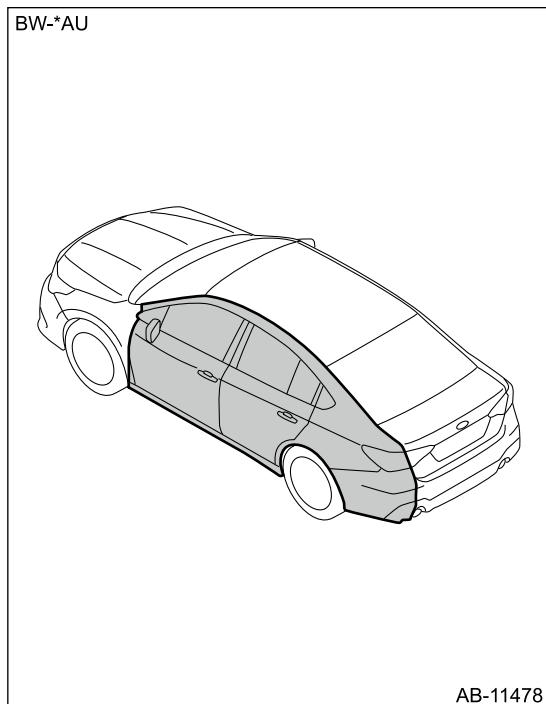

- Side impact sensor (front door), plate door, pad front door inner, side impact sensor (center pillar), Side impact sensor (under the rear center seat), plate sensor cover Side impact sensor (under the rear center seat), and side impact sensor (rear wheel house) are cracked or deformed.
- Mounting bracket is cracked or deformed.
- Connector is scratched, cracked or deformed.



## 9. STEERING ROLL CONNECTOR

Check for the following, and replace the damaged parts such as cracks, deformation, etc. with new parts.

- Combination switch
- Steering roll connector

## 10. CHECK STEERING SYSTEM

For steering wheel assembly, column assembly steering, universal joint assembly steering, and steering gearbox assembly, check the following items, and if there is anything out of standard value, it is considered to be damaged. If so, replace it with a new part.

- Check the following items for the column assembly steering.  [Ref. to POWER ASSISTED SYSTEM \(POWER STEERING\)>Steering Column>INSPECTION.](#)
  - Mounting conditions and deflection of front and rear, upward and downward directions of the steering wheel assembly and column assembly steering.
  - Deflection of front and rear, upward and downward directions, and mounting condition to vehicle body of the column assembly steering. (After a collision, absorbing part of the column assembly steering may have been operated.)
- Check for deflection and the swing load of the universal joint assembly steering.  [Ref. to POWER ASSISTED SYSTEM \(POWER STEERING\)>Universal Joint>INSPECTION.](#)
- Check the following items for the steering gearbox assembly.  [Ref. to POWER ASSISTED SYSTEM \(POWER STEERING\)>Electric Power Steering Gearbox>INSPECTION.](#)
  - Rack sliding resistance and deflection
  - Input shaft play
  - Rotational resistance of gearbox

## 11. DRIVER'S SEAT

### Caution:



**If scratches, cracks or deformation are detected, be sure to replace the seat frame assembly cushion as a whole unit.**

1. Check for the following, and replace the damaged parts with new parts.
  - Body or bracket of the belt assembly front INN is scratched, cracked or deformed.
  - Frame assembly is cracked or deformed.
  - Headrest assembly for deformation or play.
  - If the seat surface is damaged or frayed, replace the cover with a new part.
  - If the seat surface and seat heater unit are replaced, replace the hog ring and hang wire with new parts.

## 12. PASSENGER'S SEAT

**Caution:**

- **Do not disassemble the seat frame assembly cushion, slide rail and load sensor, which are integrated in an assembly component. If scratches, cracks or deformation are detected, be sure to replace the seat frame assembly cushion as a whole unit.**
- **If scratches, cracks or deformation are detected, be sure to replace the seat frame assembly cushion as a whole unit.**

1. Check for the following, and replace the damaged parts with new parts.
  - Body or bracket of the belt assembly front INN is scratched, cracked or deformed.
  - Seat frame assembly backrest is cracked or deformed.
  - Headrest assembly for deformation or play.
  - If the seat surface is damaged or frayed, replace the cover with a new part.
  - If the seat surface and seat heater unit are replaced, replace the hog ring and hang wire with new parts.
2. When the passenger's seat is removed (including the case that the bolts are loosened), perform [Rezero] of the occupant detection system.  [Ref. to AIRBAG\(DIAGNOSTICS\)>Rezero.](#)
3. When the passenger's seat is removed (including the case that the bolts are loosened), make sure that the occupant detection system operates normally.  [Ref. to SEAT BELT SYSTEM>Seat Belt Warning System.](#)
4. Use the Subaru Select Monitor to check whether the passenger's seat belt buckle switch is operating normally.  [Ref. to AIRBAG\(DIAGNOSTICS\)>Data Monitor>OPERATION.](#)

### 13. CHECK OTHER COMPONENTS

Check the following parts, and replace any damaged parts with new parts.

1. Check the following parts equipped with the direct type connector for damage, and also check each harness for pinch and connector damage. Replace the main harness as a unit if damage is found.
  - Knee airbag module
  - Curtain airbag module
  - Front seat belt pretensioner & adaptive force limiter
  - Lap seat belt pretensioner
2. Check the seat cushion, backrest, slide rail and headrest for installation condition and looseness.
3. If any break or fray is found in the cover front seat backrest of the driver's seat or passenger's seat, the side airbag system may not operate normally. In this case, replace the cover front seat backrest with a new part.
4. If the securing clip mounting area of curtain airbag module or the bracket assist rail is deformed or cracked, replace the defective part.

## AIRBAG SYSTEM > Driver's Airbag Module

### REMOVAL

#### Caution:

Refer to "CAUTION" of "General Description" before handling the airbag system components.  [Ref. to AIRBAG SYSTEM>General Description>CAUTION.](#)

1. Set the steering wheel to the straight-ahead position.
2. Turn the ignition switch to OFF.
3. Disconnect the ground terminal from the battery sensor, and wait for at least 60 seconds before starting work.  [Ref. to REPAIR CONTENTS>NOTE > BATTERY.](#)
4. Remove the driver's airbag module.
  - (1) Using a hexagon wrench etc. wrapped by protective tape, insert the snap pins and release the locks (three locations).

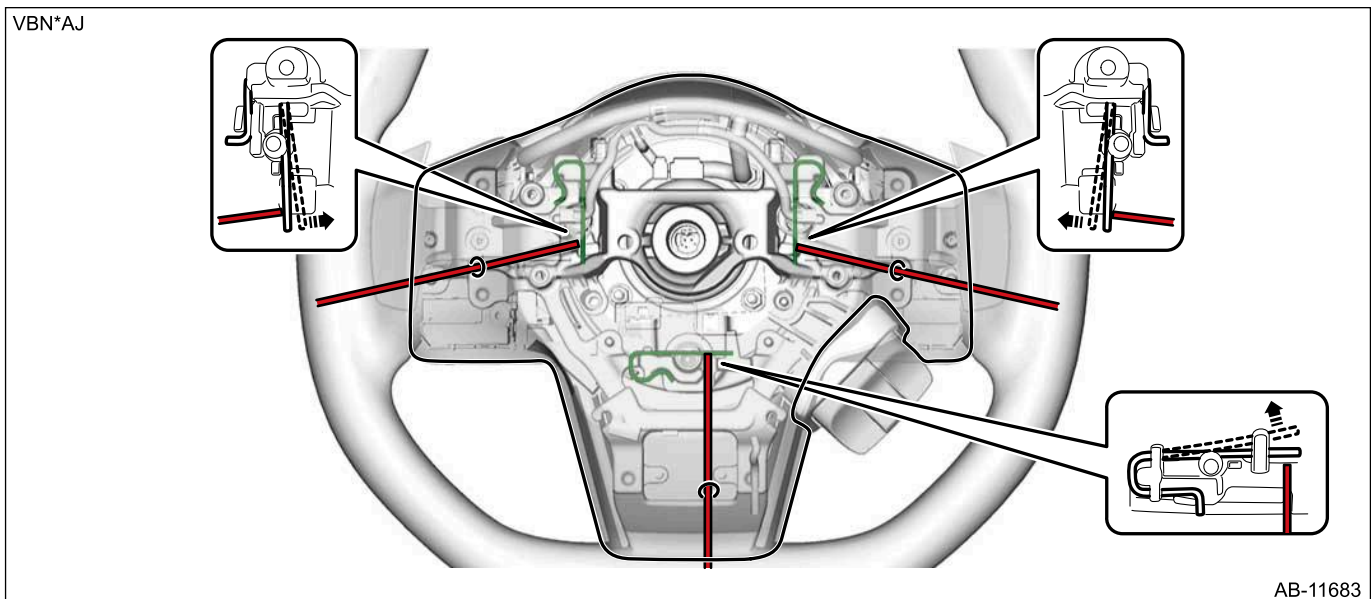

- (2) Disconnect the horn harness and airbag connector, and remove the driver's airbag module.  [Ref. to AIRBAG SYSTEM>Airbag Connector>PROCEDURE > KNEE AIRBAG MODULE, DRIVER'S AIRBAG MODULE & LAP SEAT BELT PRETENSIONER.](#)

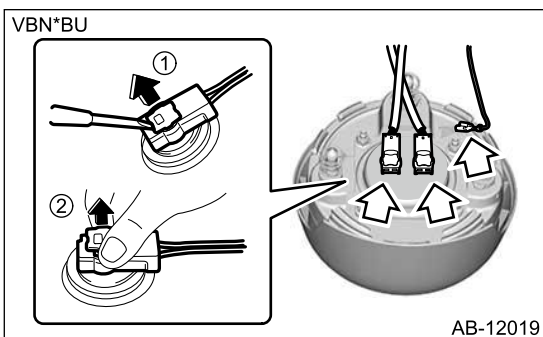

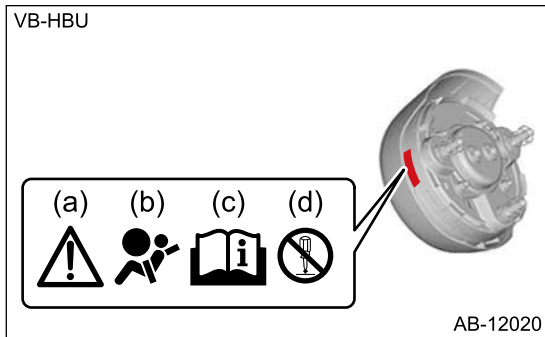

Meaning of pictograms indicated on the label

- (a) Flammable explosive substance encapsulated parts; be careful of handling.
- (b) Indicates that this part is an airbag module.
- (c) Before handling, always refer to "CAUTION" of "General Description" in "AIRBAG SYSTEM" in the service manual.  
For the disposal procedures of the airbag modules, refer to "Airbag Module Disposal".
- (d) Do not disassemble the airbag module.

## AIRBAG SYSTEM > Driver's Airbag Module

### INSTALLATION

#### Caution:

- Refer to "CAUTION" of "General Description" before handling the airbag system components. [Ref. to AIRBAG SYSTEM>General Description>CAUTION.](#)
- Do not allow harness and connectors to interfere or get tangled up with other parts.

1. Before installation, inspect the following items and replace any faulty part with a new one.
  - Airbag module is cracked or deformed.
  - Harness and/or connector is cracked, deformed or open.
  - Harness wire is exposed.
  - The steering wheel assembly is in the way, making it difficult to install the airbag module.
  - The clearance between the driver's airbag module and steering wheel assembly is not constant.
2. Install the driver's airbag module.

#### Note:

- Make sure that the snap pin is securely placed inside the guide before installing the airbag module.
- After the airbag module is installed, make sure that the airbag module locks (three positions) are securely locked.



- (1) Connect the airbag connector. [Ref. to AIRBAG SYSTEM>Airbag Connector>PROCEDURE > KNEE AIRBAG MODULE, DRIVER'S AIRBAG MODULE & LAP SEAT BELT PRETENSIONER.](#)
  - (2) Connect the horn harness.
  - (3) Press in the locks (three positions) to install the airbag module.
3. Connect the ground terminal to battery sensor. [Ref. to REPAIR CONTENTS>NOTE > BATTERY.](#)
  4. Check that the horn sounds.

## AIRBAG SYSTEM > Knee Airbag Module

### REMOVAL

#### Caution:

Refer to "CAUTION" of "General Description" before handling the airbag system components.  [Ref. to AIRBAG SYSTEM>General Description>CAUTION.](#)

1. Turn the ignition switch to OFF.
2. Disconnect the ground terminal from the battery sensor, and wait for at least 60 seconds before starting work.  [Ref. to REPAIR CONTENTS>NOTE > BATTERY.](#)
3. Remove the cover LWR driver.  [Ref. to EXTERIOR/INTERIOR TRIM>Instrument Panel Lower Cover>REMOVAL.](#)
4. Remove the knee airbag module.
  - (1) Disconnect the airbag connector.  [Ref. to AIRBAG SYSTEM>Airbag Connector>PROCEDURE > KNEE AIRBAG MODULE, DRIVER'S AIRBAG MODULE & LAP SEAT BELT PRETENSIONER.](#)
  - (2) Remove the data link connector.
  - (3) Remove the nuts, and remove the knee airbag module.

VB-HBU

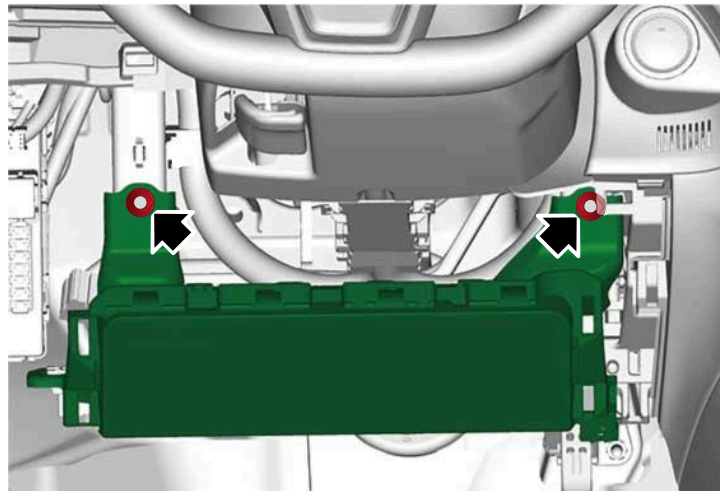
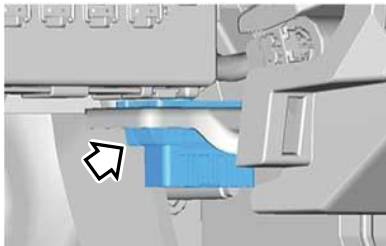
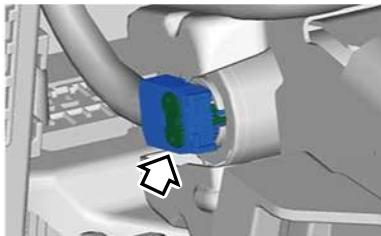

AB-12021

BWT\*AU

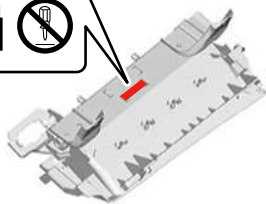
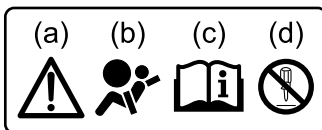

AB-11447

Meaning of pictograms indicated on the label

- (a) Flammable explosive substance encapsulated parts; be careful of handling.
- (b) Indicates that this part is an airbag module.



- (c) Before handling, always refer to "CAUTION" of "General Description" in "AIRBAG SYSTEM" in the service manual.  
For the disposal procedures of the airbag modules, refer to "Airbag Module Disposal".
- (d) Do not disassemble the airbag module.

## AIRBAG SYSTEM > Knee Airbag Module

### INSTALLATION

#### Caution:

- Refer to "CAUTION" of "General Description" before handling the airbag system components.  [Ref. to AIRBAG SYSTEM>General Description>CAUTION.](#)
- Do not allow harness and connectors to interfere or get tangled up with other parts.



1. Before installation, inspect the following items and replace any faulty part with a new one.
  - Knee airbag module is cracked or deformed.
  - Claw portion of the metallic case of knee airbag module is not aligned with the plastic cover.
  - Knee airbag module bracket is cracked or deformed.
  - Harness and/or connector is cracked, deformed or open.
  - Harness wire is exposed.
  - Depending on the condition of the beam steering COMPL, installation of the knee airbag module is difficult.
2. Install the knee airbag module.  
**Tightening torque:**  
7.5 N·m (0.8 kgf-m, 5.5 ft-lb)
3. Connect the airbag connector.  [Ref. to AIRBAG SYSTEM>Airbag Connector>PROCEDURE > KNEE AIRBAG MODULE, DRIVER'S AIRBAG MODULE & LAP SEAT BELT PRETENSIONER.](#)
4. Install the data link connector.
5. Install the cover LWR driver.  [Ref. to EXTERIOR/INTERIOR TRIM>Instrument Panel Lower Cover>INSTALLATION.](#)
6. Connect the ground terminal to battery sensor.  [Ref. to REPAIR CONTENTS>NOTE > BATTERY.](#)

## AIRBAG SYSTEM > Passenger's Airbag Module

### REMOVAL

#### Caution:

Refer to "CAUTION" of "General Description" before handling the airbag system components.  [Ref. to AIRBAG SYSTEM>General Description>CAUTION.](#)

1. Turn the ignition switch to OFF.
2. Disconnect the ground terminal from the battery sensor, and wait for at least 60 seconds before starting work.  [Ref. to REPAIR CONTENTS>NOTE > BATTERY.](#)
3. Remove the instrument panel assembly.  [Ref. to EXTERIOR/INTERIOR TRIM>Instrument Panel Assembly>REMOVAL.](#)
4. Remove the screws and release the claws, and remove the passenger's airbag module.

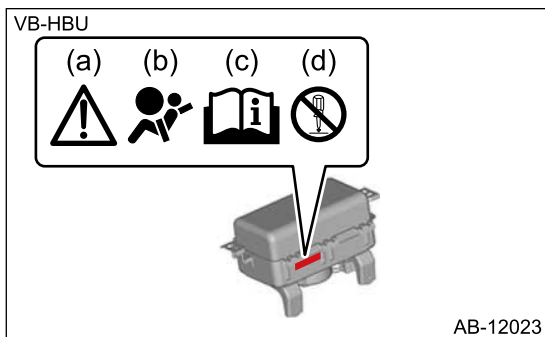
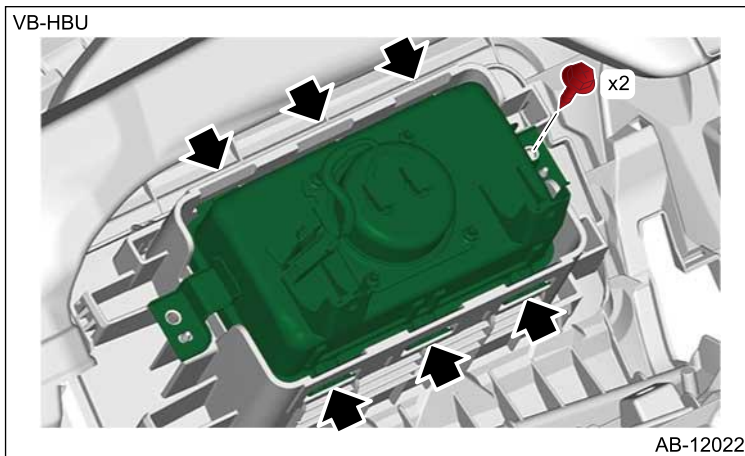

Meaning of pictograms indicated on the label

- (a) Flammable explosive substance encapsulated parts; be careful of handling.
- (b) Indicates that this part is an airbag module.
- (c) Before handling, always refer to "CAUTION" of "General Description" in "AIRBAG SYSTEM" in the service manual.  
For the disposal procedures of the airbag modules, refer to "Airbag Module Disposal".
- (d) Do not disassemble the airbag module.

## AIRBAG SYSTEM > Passenger's Airbag Module

### INSTALLATION

**Caution:**

- Refer to “CAUTION” of “General Description” before handling the airbag system components.  [Ref. to AIRBAG SYSTEM>General Description>CAUTION.](#)
- Do not allow harness and connectors to interfere or get tangled up with other parts.

1. Before installation, inspect the following items and replace any faulty part with a new one.
  - Passenger’s airbag lid (instrument panel surface) is cracked or deformed.
  - Airbag module is cracked or deformed.
  - Harness and/or connector is cracked, deformed or open.
  - Harness wire is exposed.
  - Mounting bracket is cracked or deformed.
2. Install the passenger’s airbag module.

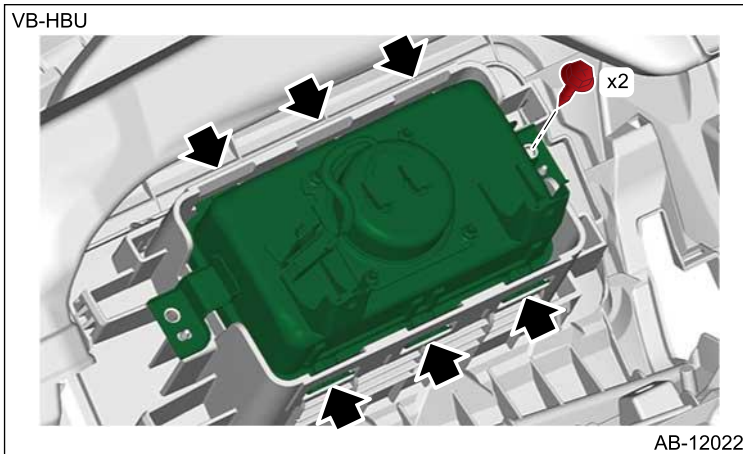

3. Install the instrument panel assembly.  [Ref. to EXTERIOR/INTERIOR TRIM>Instrument Panel Assembly>INSTALLATION.](#)
4. Connect the ground terminal to battery sensor.  [Ref. to REPAIR CONTENTS>NOTE > BATTERY.](#)





## AIRBAG SYSTEM > Side Airbag Module

### REMOVAL



#### Caution:

- Refer to "CAUTION" of "General Description" before handling the airbag system components.  [Ref. to AIRBAG SYSTEM>General Description>CAUTION.](#)
- Do not disassemble the backrest assembly of RECARO® seat. Replace the backrest assembly with a new part if faulty.

1. Turn the ignition switch to OFF.
2. Disconnect the ground terminal from the battery sensor, and wait for at least 60 seconds before starting work.  [Ref. to REPAIR CONTENTS>NOTE > BATTERY.](#)
3. Remove the front seats.  [Ref. to SEATS>Front Seat>REMOVAL.](#)
4. Remove the belt assembly front INN.  [Ref. to SEAT BELT SYSTEM>Front Seat Belt>REMOVAL > BELT ASSEMBLY FRONT INN.](#)
5. Separate the backrest assembly and the seat cushion assembly.  [Ref. to SEATS>Front Seat>DISASSEMBLY.](#)
6. Remove the seat pad assembly backrest and the cover front seat backrest.
  - (1) Remove the plastic fastener at the back side (bottom) of backrest assembly.
  - (2) Open the fastener at the rear side of backrest assembly.

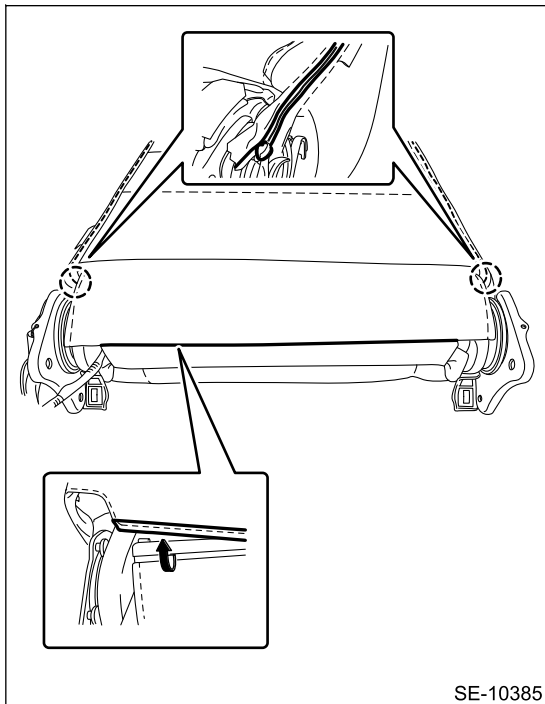

- (3) Remove the hog rings and the resin fasteners (a) on the left and right.

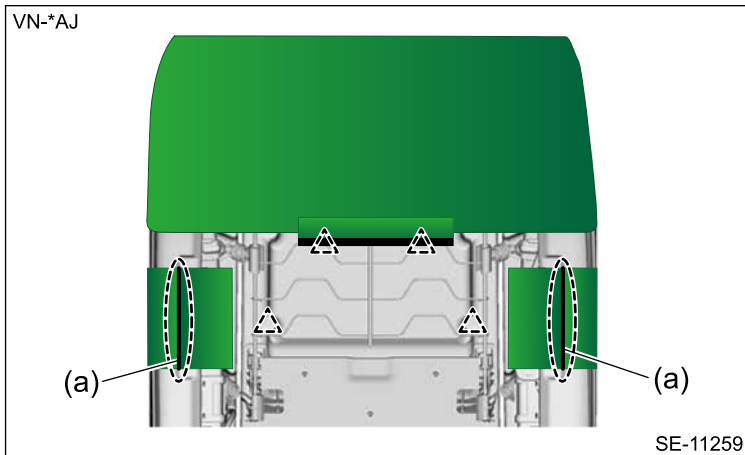

(4) Remove the hexagon cap nut.

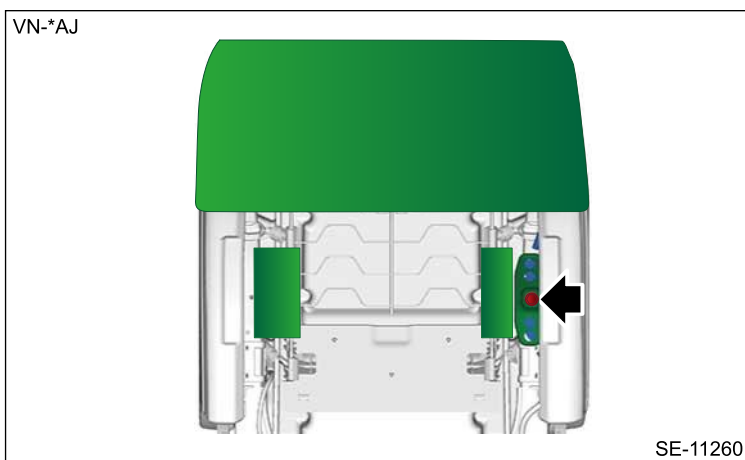

(5) Remove the seat pad assembly backrest and the cover front seat backrest from the seat backrest assembly.

**7.** Remove the side airbag module.

**Caution:**  
**Do not open the protective cover of the side airbag module. If any damage is present in the protective cover or the cloth of side airbag module comes out from the protective cover slit, replace the side airbag module with a new part.**

(1) Remove the self-locking nut.

(2) While taking care not to damage the airbag protective cover, remove the side airbag module.

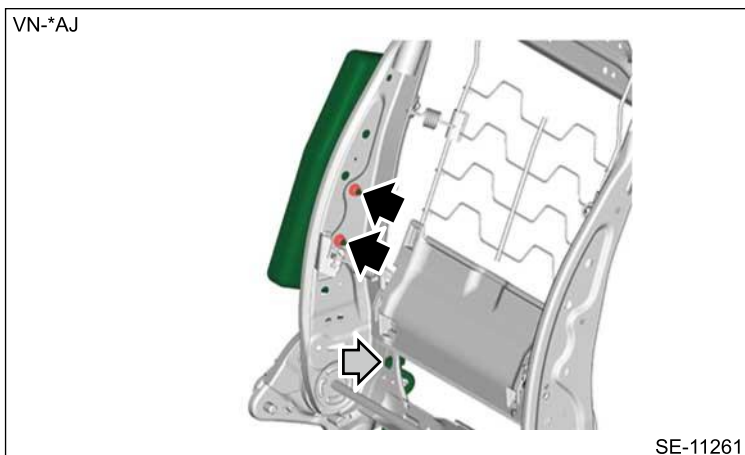

## AIRBAG SYSTEM > Side Airbag Module

### INSTALLATION

#### Caution:

- Refer to "CAUTION" of "General Description" before handling the airbag system components.  [Ref. to AIRBAG SYSTEM>General Description>CAUTION.](#)
- Do not reuse the mounting nuts of the airbag module. Be sure to replace the self-locking nuts with new ones.
- Make sure that the side airbag module is installed as shown in the figure.

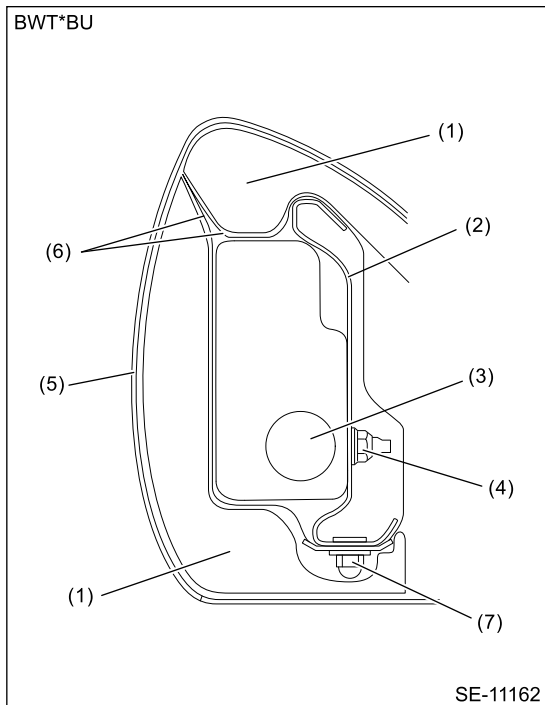

- |                                 |                               |                             |
|---------------------------------|-------------------------------|-----------------------------|
| (1) Seat pad ASSY backrest      | (4) Self-locking nut          | (6) Side airbag guide cloth |
| (2) Seat frame ASSY backrest    | (5) Cover front seat backrest | (7) Hexagon cap nut         |
| (3) Side airbag module inflator |                               |                             |

1. Before installation, inspect the following items and replace any faulty part with a new one.
  - Make sure that there is no foreign matter on side airbag module.
  - Front seat, airbag module and mounting bracket are damaged or deformed.
  - Harness and/or connector is cracked, deformed or open.
  - Harness wire is exposed.
2. Using a new self-locking nut, install the side airbag module.

#### Tightening torque:





6 N·m (0.6 kgf-m, 4.4 ft-lb)

3. Assemble the front seat.  [Ref. to SEATS>Front Seat>ASSEMBLY.](#)

#### Caution:

**After restoring the seat, operate the reclining and sliding mechanisms to check that the side airbag harness is not caught.**

4. Install the belt assembly front INN.  [Ref. to SEAT BELT SYSTEM>Front Seat Belt>INSTALLATION > BELT ASSEMBLY FRONT INN.](#)

- 5.** Install the front seat.  [Ref. to SEATS>Front Seat>INSTALLATION.](#)
- 6.** Connect the ground terminal to battery sensor.  [Ref. to REPAIR CONTENTS>NOTE > BATTERY.](#)
- 7.** If the passenger's seat is removed, perform [Rezeroing] in the occupant detection system.  [Ref. to AIRBAG\(DIAGNOSTICS\)>Rezero.](#)
- 8.** If the passenger's seat is removed, perform "Occupant Detection System Inspection" to check if the occupant detection system operates normally.  [Ref. to SEAT BELT SYSTEM>Seat Belt Warning System>INSPECTION.](#)



## AIRBAG SYSTEM > Curtain Airbag Module

### REMOVAL



#### Caution:

Always refer to "CAUTION" of "General Description" before handling the airbag system components.  [Ref. to AIRBAG SYSTEM>General Description>CAUTION.](#)

1. Turn the ignition switch to OFF.
2. Disconnect the ground terminal from the battery sensor, and wait for at least 60 seconds before starting work.  [Ref. to REPAIR CONTENTS>NOTE > BATTERY.](#)
3. Remove the trim panel roof assembly.  [Ref. to EXTERIOR/INTERIOR TRIM>Roof Trim>REMOVAL.](#)
4. Remove the curtain airbag module.

#### Caution:

- Be careful not to damage the curtain airbag module during removal.
- Do not cut the tape wrapped around the curtain airbag module.
- Do not reuse any clips and spacers if they are removed from the vehicle once.
- Remove the modules in order starting from the vehicle front.

#### Note:

Remove the securing clip of curtain airbag module in the following procedures.

1. Using a pair of nippers, cut off section (a) of the clip bushing.
2. Remove the clip pin while holding the lock (b) with needle nose pliers.
3. Release the locks (c) of the clips bushing at two locations at the top and bottom completely using thin flat head screwdriver (d), and remove the clip bushing.

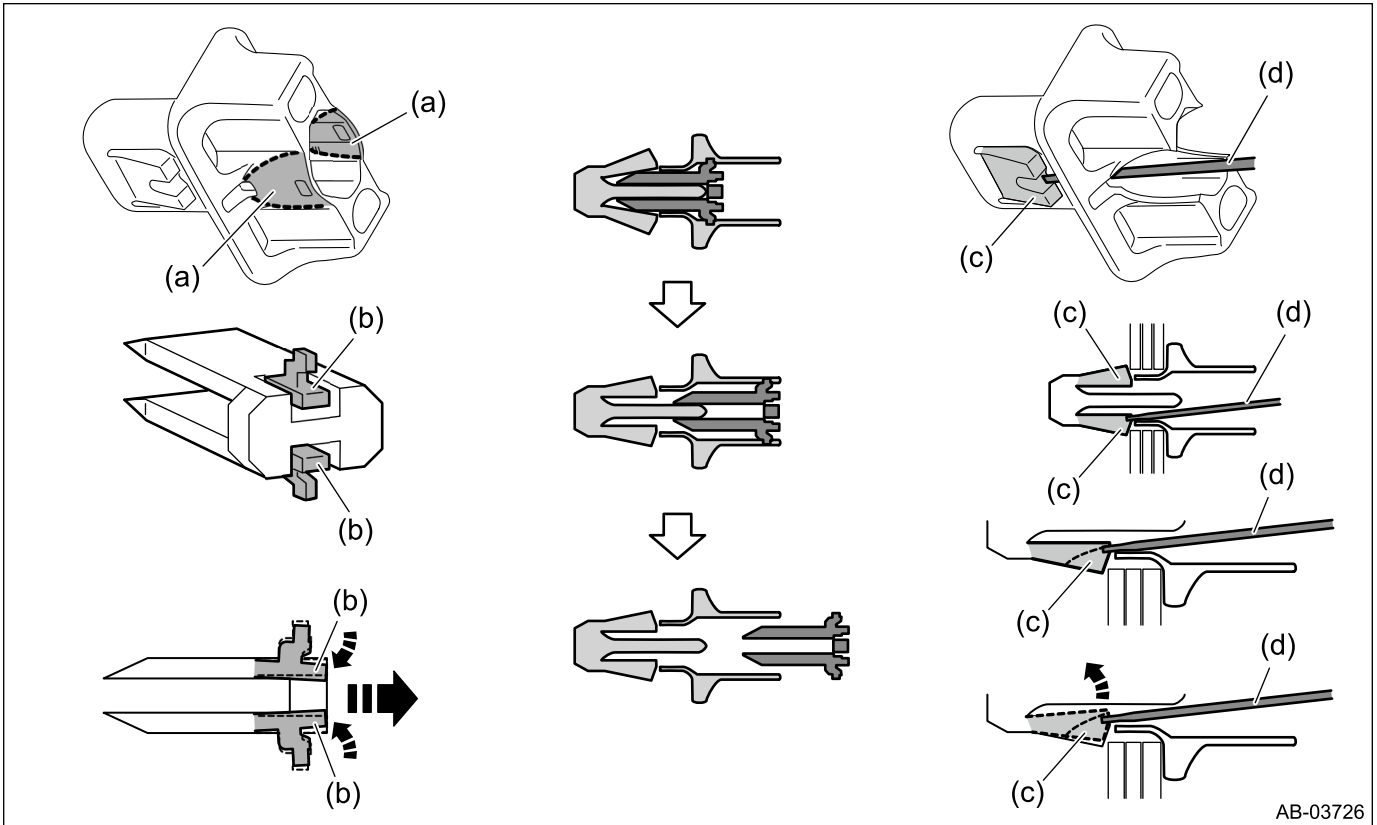

(1) Disconnect the airbag connector.  [Ref. to AIRBAG SYSTEM>Airbag Connector>PROCEDURE > CURTAIN AIRBAG MODULE.](#)

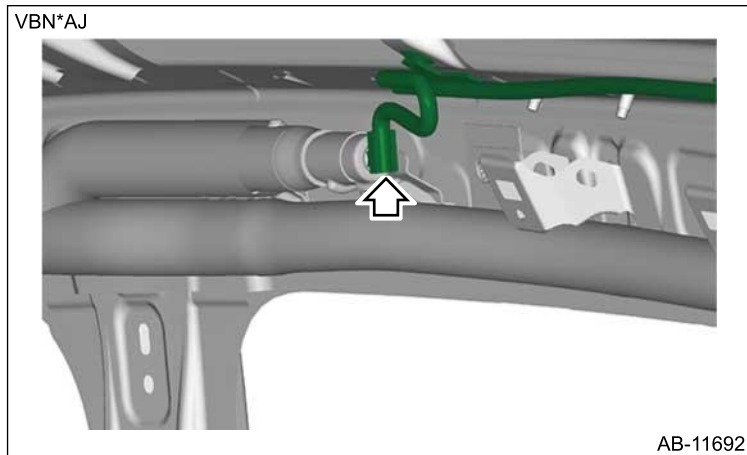

(2) Remove all the bolts and clips, and remove the curtain airbag module.

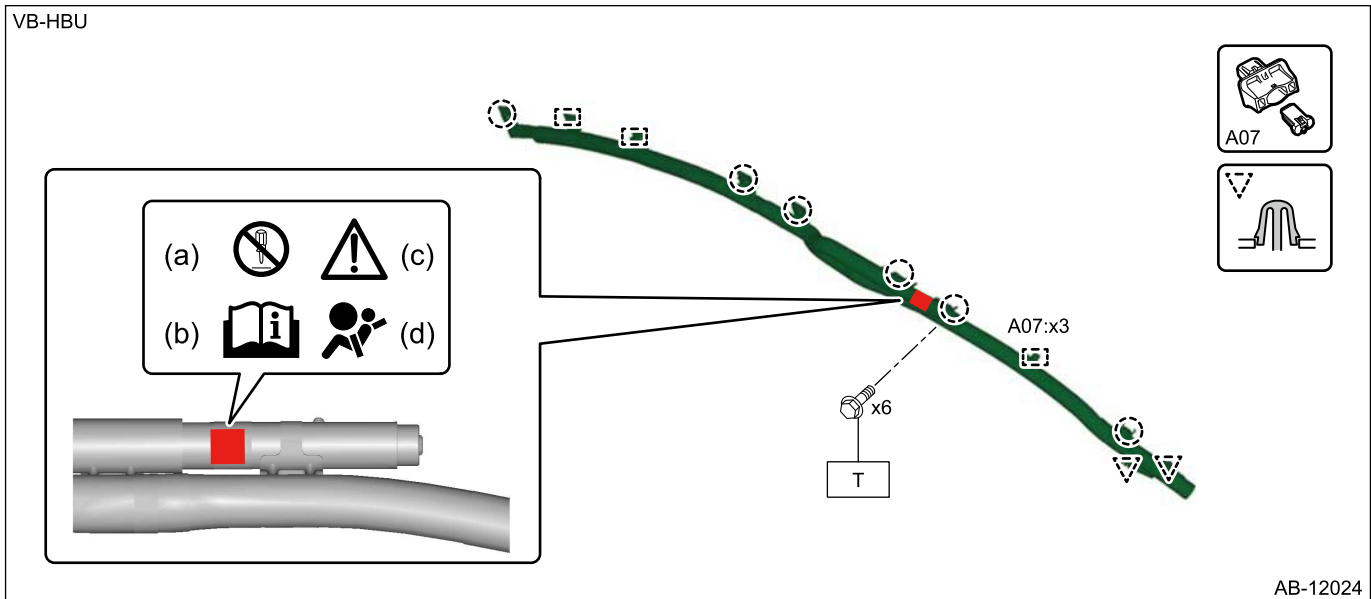

Meaning of pictograms indicated on the label

- (a) Do not disassemble the airbag module.
- (b) Before handling, always refer to "CAUTION" of "General Description" in "AIRBAG SYSTEM" in the service manual.

For the disposal procedures of the airbag modules, refer to "Airbag Module Disposal".

- (c) Flammable explosive substance encapsulated parts; be careful of handling.
- (d) Indicates that this part is an airbag module.

## AIRBAG SYSTEM > Curtain Airbag Module

### INSTALLATION

**Caution:**

- Refer to "CAUTION" of "General Description" before handling the airbag system components.  [Ref. to AIRBAG SYSTEM>General Description>CAUTION.](#)
- When installing the curtain airbag module, install a specified part at specified place.
- Be careful not to damage the curtain airbag module during installation.
- Do not cut the tape wrapped around the curtain airbag module.
- Do not reuse any clips and spacers if they are removed from the vehicle once.
- Make sure that there are no foreign matter on airbag module.
- If deformation or crack is found in the bracket assist rail by visual check, replace the defective part.
- If deformation is found in the clip mounting holes of the side rail and rear quarter metal sections, repair or replace the defective part.

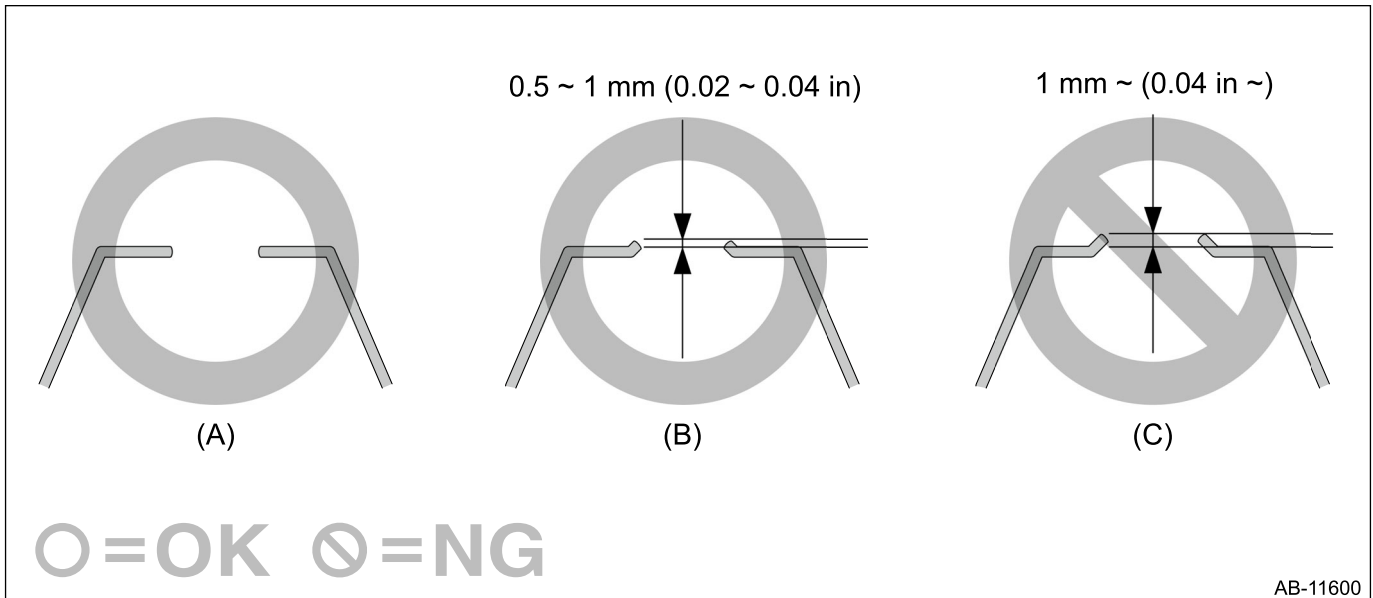

- (A) If no deformation is found or the amount of deformation is less than 0.5 mm (0.02 in), install the curtain airbag module.
- (B) If the amount of deformation is 0.5 — 1 mm (0.02 — 0.04 in), correct the deformed section to be flat and install the curtain airbag module.
- (C) If deformation is more than 1 mm (0.04 in), replace the deformed part together with the panel. Refer to Body Repair Manual for body panel replacement.

1. Before installation, inspect the following items and replace any faulty part with a new one.
  - Airbag cover is scratched or torn.
  - The tape wrapped around the airbag is cut or broken.
  - Harness and/or connector is cracked, deformed or open.
  - Harness wire is exposed.
  - Mounting bracket is cracked or deformed.
2. Install the curtain airbag module.

**Caution:**

**Make sure that the curtain airbag module is installed so that it is not twisted 360° partially.**

- (1) Install a new clip bushing and a spacer to the clip installation position of the curtain airbag module.
- (2) Tighten the bolt.

**Tightening torque:**

7.5 N·m (0.8 kgf-m, 5.5 ft-lb)

- (3) Install a new clip pin.

**Caution:**

- Press the clip pin securely into the clip bushing.
- After pressing the clip pin securely, make sure that the heights of the clip bushing top surface and the clip pin top surface are  $9.9 \pm 0.2$  mm ( $0.39 \pm 0.01$  in).

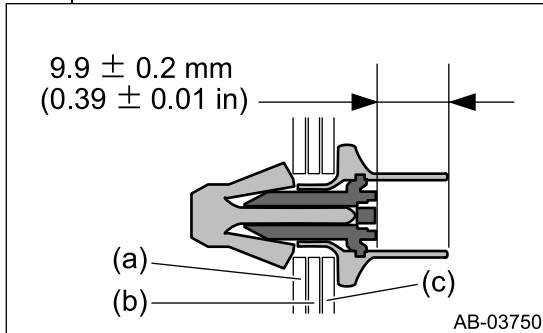

- (a) Body panel
- (b) Spacer
- (c) Airbag module tab portion

- (4) Connect the airbag connector.  [Ref. to AIRBAG SYSTEM>Airbag Connector>PROCEDURE > CURTAIN AIRBAG MODULE.](#)

- 3.** Install the trim panel roof assembly.  [Ref. to EXTERIOR/INTERIOR TRIM>Roof Trim>INSTALLATION.](#)

- 4.** Connect the ground terminal to battery sensor.  [Ref. to REPAIR CONTENTS>NOTE > BATTERY.](#)





## AIRBAG SYSTEM > Airbag Control Module

### REMOVAL



#### Caution:

- Refer to "CAUTION" of "General Description" before handling the airbag system components.  [Ref. to AIRBAG SYSTEM>General Description>CAUTION.](#)
- Do not disassemble the airbag control module.
- If the airbag control module is deformed or if there is any trace of water on the module, replace the airbag control module with a new one.
- Do not drop the airbag control module.
- After removal, keep the airbag control module on a dry, clean surface away from moisture, heat and dust.

1. Disconnect the ground terminal from the battery sensor, and wait for at least 60 seconds before starting work.  [Ref. to REPAIR CONTENTS>NOTE > BATTERY.](#)
2. Remove the console box assembly.  [Ref. to EXTERIOR/INTERIOR TRIM>Console Box>REMOVAL.](#)
3. Remove the cover center side.  [Ref. to EXTERIOR/INTERIOR TRIM>Center Console>REMOVAL.](#)
4. Remove the airbag control module.
  - (1) Disconnect the airbag connector.  [Ref. to AIRBAG SYSTEM>Airbag Connector>PROCEDURE > AIRBAG CONTROL MODULE.](#)
  - (2) Remove the flange bolt and nuts and remove the airbag control module.

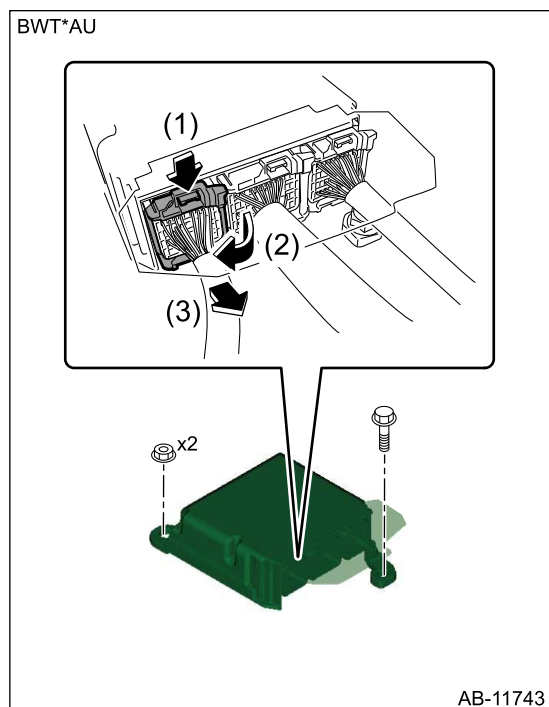





## AIRBAG SYSTEM > Airbag Control Module

### INSTALLATION

**Caution:**

- Refer to “CAUTION” of “General Description” before handling the airbag system components.  [Ref. to AIRBAG SYSTEM>General Description>CAUTION.](#)
- Do not disassemble the airbag control module.
- If the airbag control module is deformed or if there is any trace of water on the module, replace the airbag control module with a new one.
- Do not drop the airbag control module.
- After removal, keep the airbag control module on a dry, clean surface away from moisture, heat and dust.

1. Before installation, inspect the following items and replace any faulty part with a new part.
  - Control module is deformed.
  - Control module connector is damaged.
2. Using new flange bolt and nuts, install the airbag control module.  
**Tightening torque:**  
25 N·m (2.5 kgf-m, 18.4 ft-lb)
3. Connect the airbag connector.  [Ref. to AIRBAG SYSTEM>Airbag Connector>PROCEDURE > AIRBAG CONTROL MODULE.](#)
4. Install the cover center side.  [Ref. to EXTERIOR/INTERIOR TRIM>Center Console>INSTALLATION.](#)
5. Install the console box assembly.  [Ref. to EXTERIOR/INTERIOR TRIM>Console Box>INSTALLATION.](#)
6. Connect the ground terminal to battery sensor.  [Ref. to REPAIR CONTENTS>NOTE > BATTERY.](#)
7. When the airbag control module is replaced, perform [Rezeroing] in the occupant detection system.  
 [Ref. to AIRBAG\(DIAGNOSTICS\)>Rezero.](#)

## AIRBAG SYSTEM > Impact Sensor



### REMOVAL



#### 1. Front impact sensor

##### Caution:

Refer to "CAUTION" of "General Description" before handling the airbag system components.  [Ref. to AIRBAG SYSTEM>General Description>CAUTION.](#)

1. Disconnect the ground terminal from the battery sensor, and wait for at least 60 seconds before starting work.  [Ref. to REPAIR CONTENTS>NOTE > BATTERY.](#)
2. Remove the air intake duct (rear). (When removing the sensor RH)  [Ref. to INTAKE \(INDUCTION\) \(H4DOTC\)>Air Intake Duct>REMOVAL.](#)
3. Remove the Front impact sensor.
  - (1) Disconnect the airbag connector.  [Ref. to AIRBAG SYSTEM>Airbag Connector>PROCEDURE > EACH IMPACT SENSOR.](#)
  - (2) Remove the flange bolt, and then remove Front impact sensor.
    - RH

VBN\*AJ

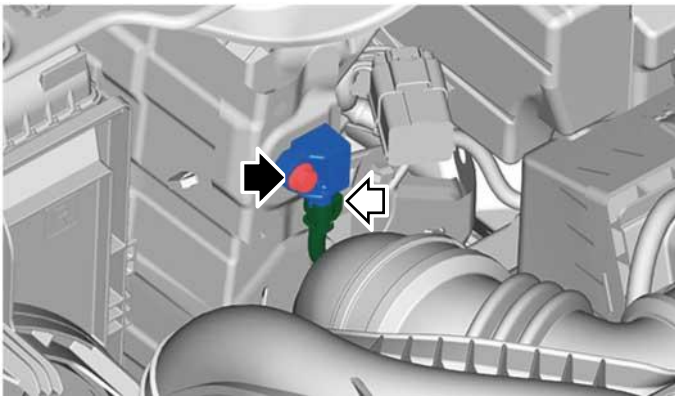

AB-11695

- LH

VBN\*AJ

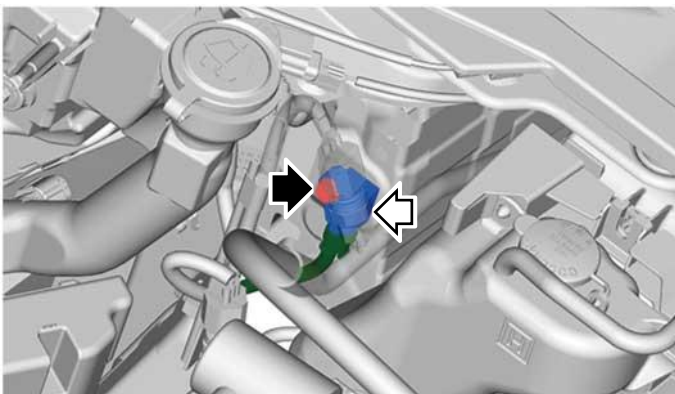

AB-11696

## 2. Side impact sensor (front door)

### Caution:

- Refer to "CAUTION" of "General Description" before handling the airbag system components. [🔗 Ref. to AIRBAG SYSTEM>General Description>CAUTION.](#)
- When Side impact sensor (front door) is removed, always replace Side impact sensor (front door) with a new part. If it is reused, sealing capability on the contacting surface of door panel may be insufficient and impact pressure may not be detected correctly.

1. Operate the power window switch to close the front door glass.
2. Disconnect the ground terminal from the battery sensor, and wait for at least 60 seconds before starting work. [🔗 Ref. to REPAIR CONTENTS>NOTE > BATTERY.](#)
3. Remove the trim panel front door. [🔗 Ref. to EXTERIOR/INTERIOR TRIM>Door Trim>REMOVAL > FRONT DOOR.](#)
4. Remove the sealing cover door front. [🔗 Ref. to EXTERIOR BODY PANELS>Sealing Cover>REMOVAL.](#)
5. Remove the Side impact sensor (front door) .

### Caution:

- Do not reuse Side impact sensor (front door) that have been removed. Always replace Side impact sensor (front door) with a new part.
- The nuts cannot be removed from Side impact sensor (front door) . Do not remove the mounting nuts.
- If the pad front door is removed with an excessive force, the panel assembly front door may be deformed. Also, if the clip is damaged, replace it with a new clip.

- (1) Release the clips, and remove the pad front door inner (a).
- (2) Disconnect the airbag connector. [🔗 Ref. to AIRBAG SYSTEM>Airbag Connector>PROCEDURE > SIDE IMPACT SENSOR \(FRONT DOOR\).](#)
- (3) Loosen the nuts, and remove Side impact sensor (front door) with the claws (b) pressed.

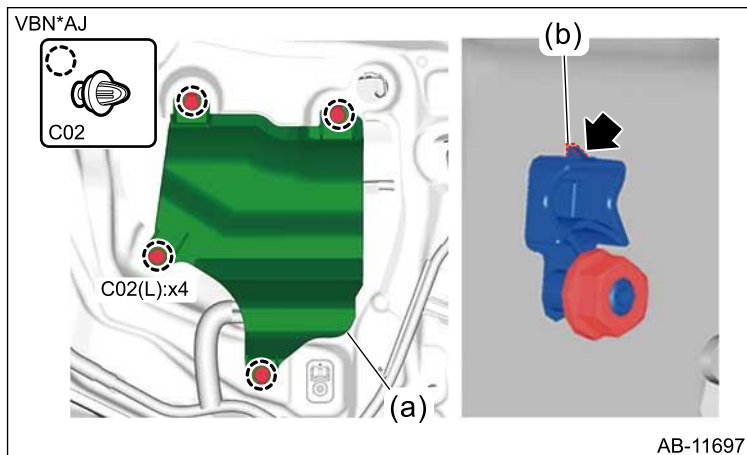

## 3. Side impact sensor (center pillar)





**Caution:**

- Refer to “CAUTION” of “General Description” before handling the airbag system components.  [Ref. to AIRBAG SYSTEM>General Description>CAUTION.](#)
- Side impact sensor (under the rear center seat) for the airbag system is located under the front center of the rear seat cushion. Be careful not to apply strong impact to the sensor when working with the rear seat cushion removed.

1. Move the seat on the side where Side impact sensor (center pillar) will be removed to the front-most position.

**Note:**

**This is to remove the seat belt retractor assembly.**

2. Disconnect the ground terminal from the battery sensor, and wait for at least 60 seconds before starting work.  [Ref. to REPAIR CONTENTS>NOTE > BATTERY.](#)
3. Remove the cover side sill front Rr and the trim panel assembly B pillar LWR.  [Ref. to EXTERIOR/INTERIOR TRIM>Lower Inner Trim>REMOVAL.](#)
4. Remove the seat belt retractor.
  - (1) Turn over the floor mat to disconnect the following connectors.
    - Front seat belt pretensioner & adaptive force limiter  [Ref. to AIRBAG SYSTEM>Airbag Connector>PROCEDURE > PASSENGER’S AIRBAG MODULE, REAR SEAT BELT PRETENSIONER, FRONT SEAT BELT PRETENSIONER & ADAPTIVE FORCE LIMITER.](#)
    - Lap pretensioner (passenger’s side)  [Ref. to AIRBAG SYSTEM>Airbag Connector>PROCEDURE > KNEE AIRBAG MODULE, DRIVER’S AIRBAG MODULE & LAP SEAT BELT PRETENSIONER.](#)
  - (2) Remove the bolt to remove the seat belt retractor.

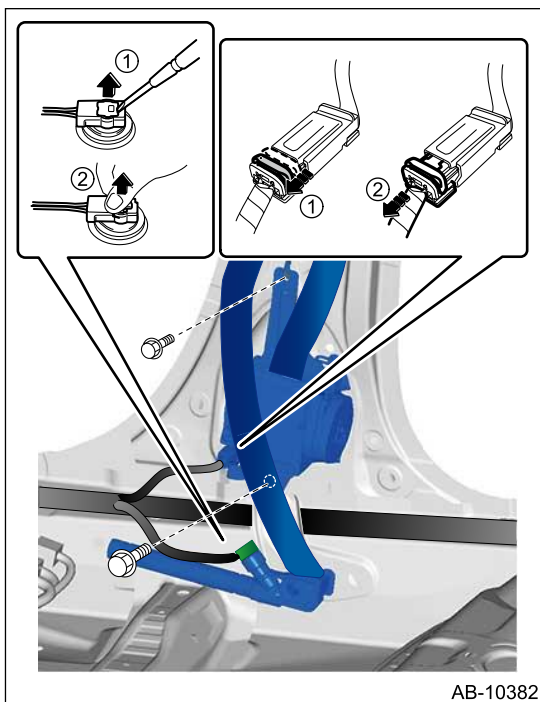

5. Remove the Side impact sensor (center pillar).
  - (1) Remove the nut, and remove the side impact sensor (center pillar).
  - (2) Disconnect the airbag connector.  [Ref. to AIRBAG SYSTEM>Airbag Connector>PROCEDURE > EACH IMPACT SENSOR.](#)

VBN\*AJ

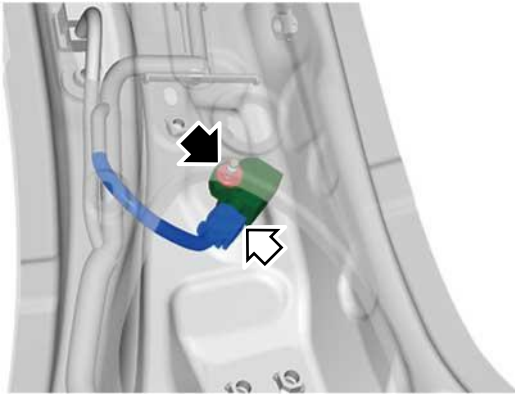





AB-11698

#### 4. Side impact sensor (rear wheel house)

**Caution:**

- Refer to "CAUTION" of "General Description" before handling the airbag system components.  [Ref. to AIRBAG SYSTEM>General Description>CAUTION.](#)
- Side impact sensor (under the rear center seat) for the airbag system is located under the front center of the rear seat cushion. Be careful not to apply strong impact to the sensor when working with the rear seat cushion removed.

1. Disconnect the ground terminal from the battery sensor, and wait for at least 60 seconds before starting work.  [Ref. to REPAIR CONTENTS>NOTE > BATTERY.](#)
2. Remove the rear seat cushion assembly and the backrest assembly.  [Ref. to SEATS>Rear Seat>REMOVAL.](#)
3. Remove the trim panel assembly C pillar LWR.  [Ref. to EXTERIOR/INTERIOR TRIM>Rear Quarter Trim>REMOVAL.](#)
4. Remove the Side impact sensor (rear wheel house).
  - (1) Disconnect the airbag connector.  [Ref. to AIRBAG SYSTEM>Airbag Connector>PROCEDURE > EACH IMPACT SENSOR.](#)
  - (2) Remove the nut, and remove the side impact sensor (rear wheel house).

VBN\*AJ

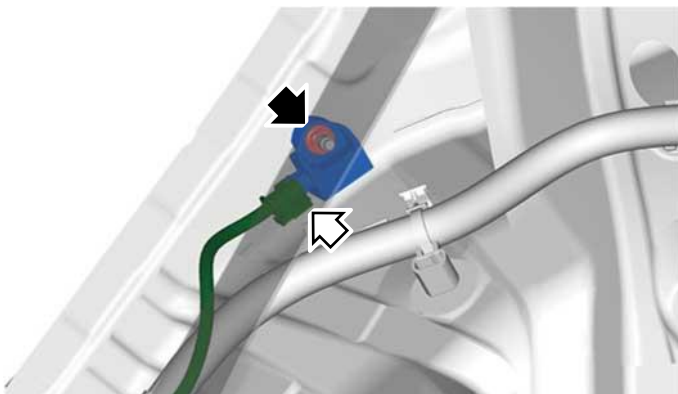



AB-11699

#### 5. Side impact sensor (under the rear center seat)

**Caution:**

- Refer to "CAUTION" of "General Description" before handling the airbag system components.  [Ref. to AIRBAG SYSTEM>General Description>CAUTION.](#)
- Side impact sensor (under the rear center seat) for the airbag system is located under the front center of the rear seat cushion. Be careful not to apply strong impact to the sensor when working with the rear seat cushion removed.

1. Disconnect the ground terminal from the battery sensor, and wait for at least 60 seconds before starting work.  [Ref. to REPAIR CONTENTS>NOTE > BATTERY.](#)
2. Remove the rear seat cushion assembly.  [Ref. to SEATS>Rear Seat>REMOVAL.](#)
3. Remove the Side impact sensor (under the rear center seat).
  - (1) Remove the clips and turn over the floor mat.
  - (2) Remove the clips and remove the plate sensor cover Side impact sensor (under the rear center seat).
  - (3) Disconnect the airbag connector.  [Ref. to AIRBAG SYSTEM>Airbag Connector>PROCEDURE > EACH IMPACT SENSOR.](#)
  - (4) Remove the flange bolt, and then remove Side impact sensor (under the rear center seat).

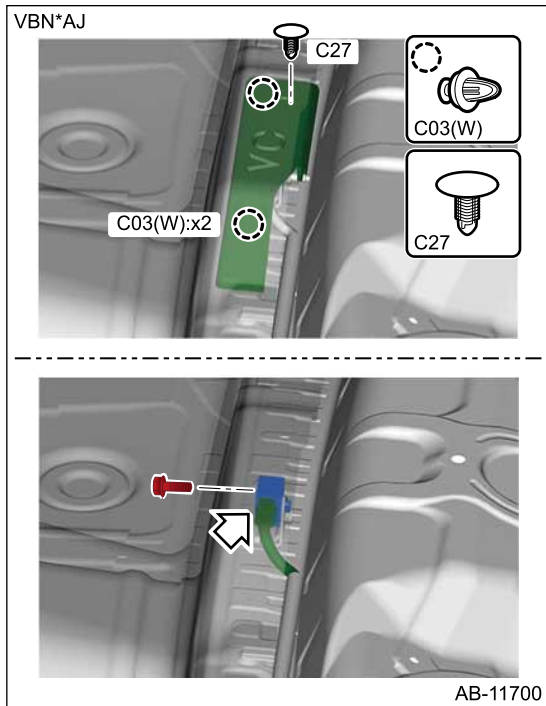

**AIRBAG SYSTEM > Impact Sensor**

**INSTALLATION**

**1. Front impact sensor**

**Caution:**

- Refer to "CAUTION" of "General Description" before handling the airbag system components.  [Ref. to AIRBAG SYSTEM>General Description>CAUTION.](#)

1. Before installation, inspect the following items and replace any faulty part with a new part.



- Front impact sensor is free from damage.
  - Connector is free from damage.
2. Using a new flange bolt, install Front impact sensor.

**Caution:**

**When installing the sensor, insert the set pin on the backside of the sensor into the hole on the body side securely.**

**Tightening torque:**

13 N·m (1.3 kgf-m, 9.6 ft-lb)

3. Connect the airbag connector.  [Ref. to AIRBAG SYSTEM>Airbag Connector>PROCEDURE > EACH IMPACT SENSOR.](#)
4. Install the air intake duct (rear). (When removing the sensor RH)  [Ref. to INTAKE \(INDUCTION\) \(H4DOTC\)>Intake Duct>INSTALLATION.](#)
5. Connect the ground terminal to battery sensor.  [Ref. to REPAIR CONTENTS>NOTE > BATTERY.](#)

## 2. Side impact sensor (front door)

**Caution:**

**Refer to "CAUTION" of "General Description" before handling the airbag system components.**  [Ref. to AIRBAG SYSTEM>General Description>CAUTION.](#)





1. Before installation, inspect the following items and replace any faulty part with a new part.
  - Side impact sensor (front door) or connector is damaged.
  - Inner panel area of the panel COMPL door front is deformed.
  - Side airbag module has been activated.
2. Attach the Side impact sensor (front door) .

**Caution:**

- **Do not reuse Side impact sensor (front door) that have been removed. Always replace Side impact sensor (front door) with a new part.**
- **The nuts cannot be removed from Side impact sensor (front door) . Do not remove the mounting nuts.**
- **Thoroughly clean the sensor mounting area before installing the Side impact sensor (front door) .**
- **When installing Side impact sensor (front door) , be sure to fix the claws of Side impact sensor (front door) into the door panel.**

**Tightening torque:**

7.5 N·m (0.8 kgf-m, 5.5 ft-lb)

3. Connect the airbag connector.  [Ref. to AIRBAG SYSTEM>Airbag Connector>PROCEDURE > SIDE IMPACT SENSOR \(FRONT DOOR\) .](#)
4. Install the pad front door inner.
5. Install the sealing cover door front.  [Ref. to EXTERIOR BODY PANELS>Sealing Cover>INSTALLATION.](#)
6. Install the trim panel front door.  [Ref. to EXTERIOR/INTERIOR TRIM>Door Trim>INSTALLATION > FRONT DOOR.](#)
7. Connect the ground terminal to battery sensor.  [Ref. to REPAIR CONTENTS>NOTE > BATTERY.](#)

## 3. Side impact sensor (center pillar)

**Caution:**

- Refer to "CAUTION" of "General Description" before handling the airbag system components.  [Ref. to AIRBAG SYSTEM>General Description>CAUTION.](#)
- Side impact sensor (under the rear center seat) for the airbag system is located under the front center of the rear seat cushion. Be careful not to apply strong impact to the sensor when working with the rear seat cushion removed.

1. Before installation, inspect the following items and replace any faulty part with a new part.
  - Side impact sensor (center pillar) or connector is damaged.
  - Side airbag module has been activated.
2. Connect the airbag connector.  [Ref. to AIRBAG SYSTEM>Airbag\\_Connector>PROCEDURE > EACH IMPACT SENSOR.](#)
3. Using a new nut, install Side impact sensor (center pillar).

**Caution:**

**When installing the sensor, insert the set pin on the backside of the sensor into the hole on the body side securely.**

**Tightening torque:**

7.5 N·m (0.8 kgf-m, 5.5 ft-lb)

4. Install the seat belt retractor.

**Tightening torque:**

Front seat belt:  [Ref. to SEAT BELT SYSTEM>General Description>COMPONENT > FRONT SEAT BELT.](#)

5. Install the trim panel assembly B pillar LWR and cover side sill front Rr.  [Ref. to EXTERIOR/INTERIOR TRIM>Lower Inner Trim>INSTALLATION.](#)
6. Connect the ground terminal to battery sensor.  [Ref. to REPAIR CONTENTS>NOTE > BATTERY.](#)

#### 4. Side impact sensor (rear wheel house)

**Caution:**

- Refer to "CAUTION" of "General Description" before handling the airbag system components.  [Ref. to AIRBAG SYSTEM>General Description>CAUTION.](#)
- Side impact sensor (under the rear center seat) for the airbag system is located under the front center of the rear seat cushion. Be careful not to apply strong impact to the sensor when working with the rear seat cushion removed.

1. Before installation, inspect the following items and replace any faulty part with a new one.
  - Side impact sensor (rear wheel house) or connector is damaged.
  - Curtain airbag module has been activated.
2. Using a new nut, install Side impact sensor (rear wheel house).



**Caution:**

**When installing the sensor, insert the set pin on the backside of the sensor into the hole on the body side securely.**

**Tightening torque:**

7.5 N·m (0.8 kgf-m, 5.5 ft-lb)

3. Connect the airbag connector.  [Ref. to AIRBAG SYSTEM>Airbag\\_Connector>PROCEDURE > EACH IMPACT SENSOR.](#)

4. Install the trim panel assembly C pillar LWR.  [Ref. to EXTERIOR/INTERIOR TRIM>Rear Quarter Trim>INSTALLATION.](#)
5. Install the backrest assembly and rear seat cushion assembly.  [Ref. to SEATS>Rear Seat>INSTALLATION.](#)
6. Connect the ground terminal to battery sensor.  [Ref. to REPAIR CONTENTS>NOTE > BATTERY.](#)

## 5. Side impact sensor (under the rear center seat)

### Caution:



- Refer to "CAUTION" of "General Description" before handling the airbag system components.  [Ref. to AIRBAG SYSTEM>General Description>CAUTION.](#)
- Side impact sensor (under the rear center seat) for the airbag system is located under the front center of the rear seat cushion. Be careful not to apply strong impact to the sensor when working with the rear seat cushion removed.
- When installing the plate sensor cover Side impact sensor (under the rear center seat), push the cover securely until it contacts the floor panel.
- If the plate sensor cover Side impact sensor (under the rear center seat) is too loose at its mounting portion and can be removed easily, replace the plate sensor cover Side impact sensor (under the rear center seat) with a new part.
- After installing the plate sensor cover Side impact sensor (under the rear center seat), make sure that the sensor harness is not caught.

1. Before installation, inspect the following items and replace any faulty part with a new one.
  - Side impact sensor (under the rear center seat) connector is damaged.
  - Plate sensor cover Side impact sensor (under the rear center seat) is damaged.
  - Side airbag module or curtain airbag module has been activated.

2. Using a new flange bolt, install Side impact sensor (under the rear center seat).

### Tightening torque:

7.5 N·m (0.8 kgf-m, 5.5 ft-lb)





3. Connect the airbag connector.  [Ref. to AIRBAG SYSTEM>Airbag Connector>PROCEDURE > EACH IMPACT SENSOR.](#)
4. Install the plate sensor cover Side impact sensor (under the rear center seat).
5. Install the floor mat clip.
6. Install the rear seat cushion assembly.  [Ref. to SEATS>Rear Seat>INSTALLATION.](#)
7. Connect the ground terminal to battery sensor.  [Ref. to REPAIR CONTENTS>NOTE > BATTERY.](#)

## AIRBAG SYSTEM > Roll Connector

### REMOVAL

#### Caution:

Refer to "CAUTION" of "General Description" before handling the airbag system components.  [Ref. to AIRBAG SYSTEM>General Description>CAUTION.](#)

1. Set the steering wheel to the straight-ahead position.
2. Disconnect the ground terminal from the battery sensor, and wait for at least 60 seconds before starting work.  [Ref. to REPAIR CONTENTS>NOTE > BATTERY.](#)
3. Remove the driver's airbag module.  [Ref. to AIRBAG SYSTEM>Driver's Airbag Module>REMOVAL.](#)
4. Remove the steering wheel assembly.  [Ref. to POWER ASSISTED SYSTEM \(POWER STEERING\)>Steering Wheel>REMOVAL.](#)
5. Remove the column cover assembly.  [Ref. to POWER ASSISTED SYSTEM \(POWER STEERING\)>Steering Column>REMOVAL.](#)
6. Remove the steering roll connector assembly.

#### Caution:

**Make sure that the steering roll connector is not turned from the original position.**

- (1) Disconnect the connector under the steering roll connector.  [Ref. to AIRBAG SYSTEM>Airbag Connector>PROCEDURE > STEERING ROLL CONNECTOR.](#)
- (2) Release the claws and remove the steering roll connector assembly.

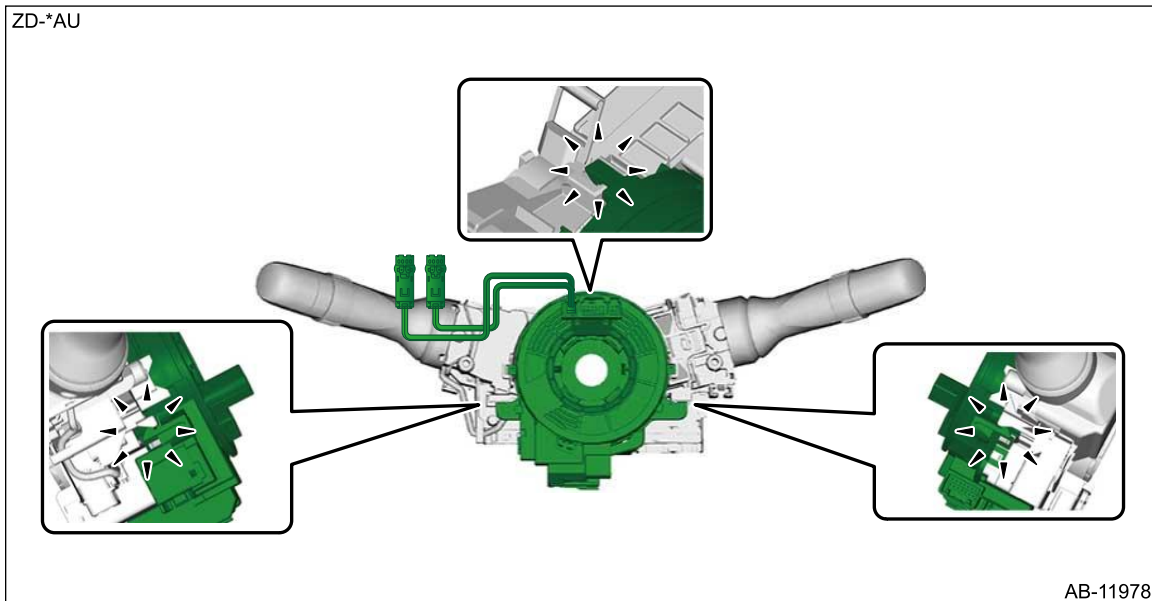

7. Remove the sensor assembly VDC steering.
  - (1) Release the claws and remove the sensor assembly VDC steering (b) from the steering roll connector (a).

ZD\*AJ

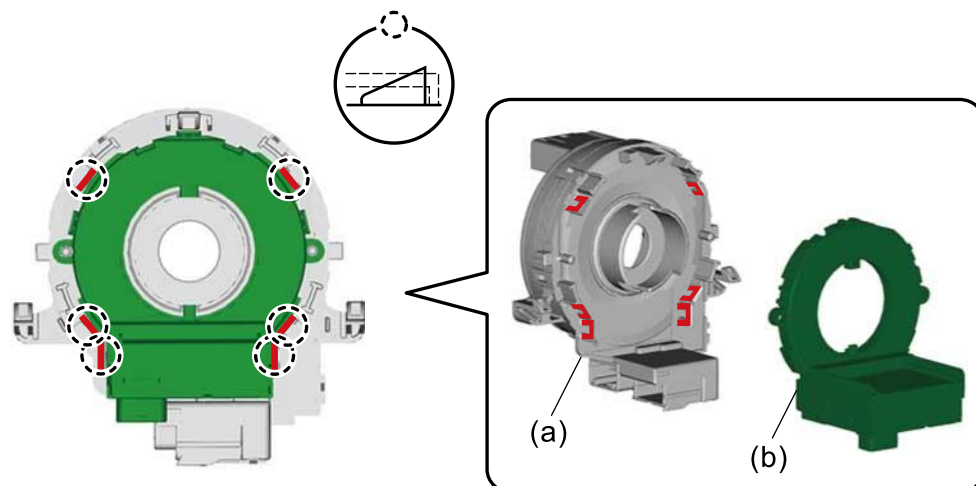

VDC10748

## AIRBAG SYSTEM > Roll Connector

### INSTALLATION

#### Caution:

Refer to "CAUTION" of "General Description" before handling the airbag system components.  [Ref. to AIRBAG SYSTEM>General Description>CAUTION.](#)

#### 1. Install the steering roll connector.

(1) Before attaching a new steering roll connector, apply a thin coat of grease.

#### Note:

**If the steering roll connector is reused, check the grease amount.**

**If grease is insufficient, additionally apply it.**

#### Preparation items:

Grease: An item contained in the steering roll connector, KYODO YUSHI Multemp L or equivalent

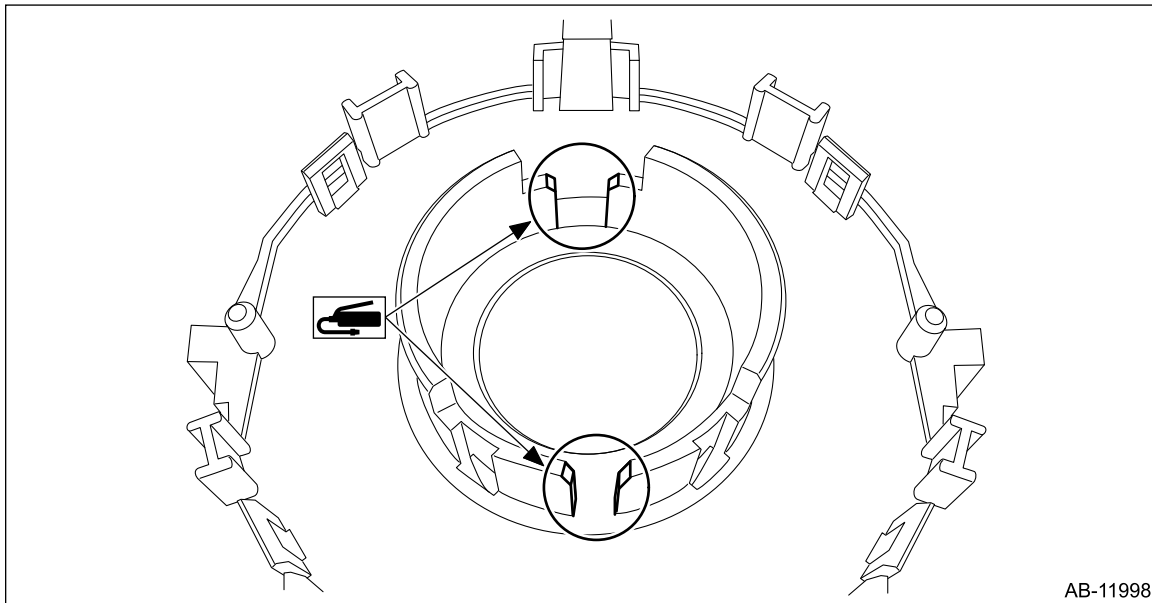

(2) When reusing the steering roll connector, align the neutral position.  [Ref. to AIRBAG SYSTEM>Roll Connector>ADJUSTMENT.](#)

(3) Align the position of the protrusion and install the sensor assembly VDC steering to the steering roll connector.

**Caution:**

**Do not rotate the steering angle sensor protrusion.**

2. Install the steering roll connector assembly.

**Note:**

**Before attaching a new steering roll connector, confirm that the position is in neutral, and snap off the neutral pin.**

3. Connect the airbag connector.  [Ref. to AIRBAG SYSTEM>Airbag Connector>PROCEDURE > STEERING ROLL CONNECTOR.](#)

4. Install the column cover assembly.  [Ref. to POWER ASSISTED SYSTEM \(POWER STEERING\)>Steering Column>INSTALLATION.](#)

5. Install the steering wheel assembly.  [Ref. to POWER ASSISTED SYSTEM \(POWER STEERING\)>Steering Wheel>INSTALLATION.](#)

6. Install the driver's airbag module.  [Ref. to AIRBAG SYSTEM>Driver's Airbag Module>INSTALLATION.](#)

7. Connect the ground terminal to battery sensor.  [Ref. to REPAIR CONTENTS>NOTE > BATTERY.](#)

8. Perform "VDC sensor midpoint setting mode".  [Ref. to VEHICLE DYNAMICS CONTROL \(VDC\)>VDC Control Module and Hydraulic Control Unit \(VDCCM&H/U\)>ADJUSTMENT > VDC SENSOR MIDPOINT SETTING MODE.](#)

## AIRBAG SYSTEM > Roll Connector

### INSPECTION

**Caution:**

**Refer to "CAUTION" of "General Description" before handling the airbag system components.**  [Ref. to AIRBAG SYSTEM>General Description>CAUTION.](#)

## 1. VISUAL INSPECTION

Check for the following, and replace the damaged parts with new parts.

- Combination switch is cracked or deformed.
- Steering roll connector is cracked or deformed.

## 2. UNIT INSPECTION

### STEERING ROLL CONNECTOR CIRCUIT (EXCEPT FOR AIRBAG CIRCUIT)

#### Caution:

- **Do not rotate the steering roll connector to more than the specified number of turns. Otherwise, the roll connector internal wire may be broken.**
- **When determining the end stop, rotate the connector slowly without applying excessive force. Applying excessive force at the end stop may break the internal wire.**

1. Adjust the steering roll connector.  [Ref. to AIRBAG SYSTEM>Roll Connector>ADJUSTMENT.](#)
2. Set the steering roll connector to the central position.
3. With the following conditions, check the resistance between the connector terminals.
  - Perform the check with the steering roll connector centered (front wheels direct straightforward).
  - Rotate the steering roll connector counterclockwise from the center (front wheels direct straightforward) to an end stop. Then, perform the check while rotating it clockwise to approximately 4.5 turns.

#### Specification:

Less than 1  $\Omega$

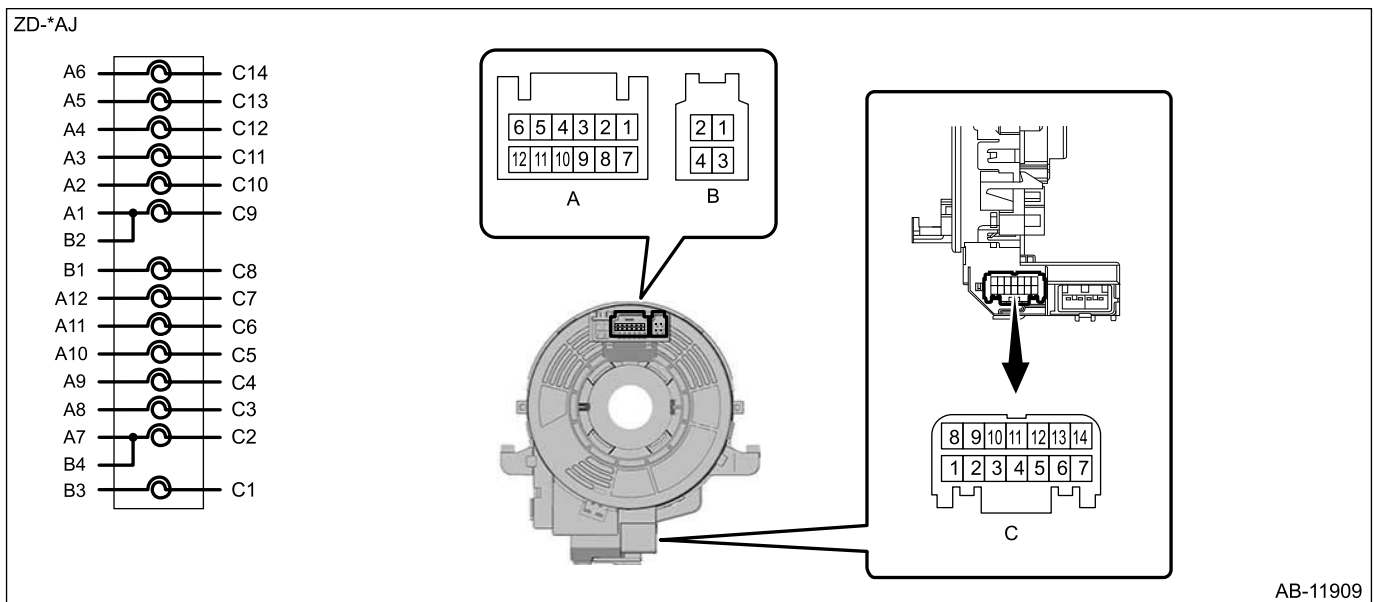

4. Replace the steering roll connector if the inspection result is not within the standard value.

## AIRBAG CIRCUIT

### Caution:

- Do not rotate the steering roll connector to more than the specified number of turns. Otherwise, the roll connector internal wire may be broken.
- When determining the end stop, rotate the connector slowly without applying excessive force. Applying excessive force at the end stop may break the internal wire.

1. Adjust the steering roll connector.  [Ref. to AIRBAG SYSTEM>Roll Connector>ADJUSTMENT.](#)
2. Set the steering roll connector to the central position.
3. Connect ST1 to the connector B and ST2 to the connector C.

### Preparation tool:

ST1: TEST HARNESS N (98299SA000)

ST2: TEST HARNESS Q (98299SA040)

- Connector B - ST1 (1N)
  - Connector C - ST2 (1Q)
4. With the following conditions, check the resistance between the connector terminals of ST1 and ST2.
    - Perform the check with the steering roll connector centered (front wheels direct straightforward).
    - Rotate the steering roll connector counterclockwise from the center (front wheels direct straightforward) to an end stop. Then, perform the check while rotating it clockwise to approximately 4.5 turns.

### Note:

The connector A is designed to short the terminals A1/A2 and A3/A4 when disconnected.

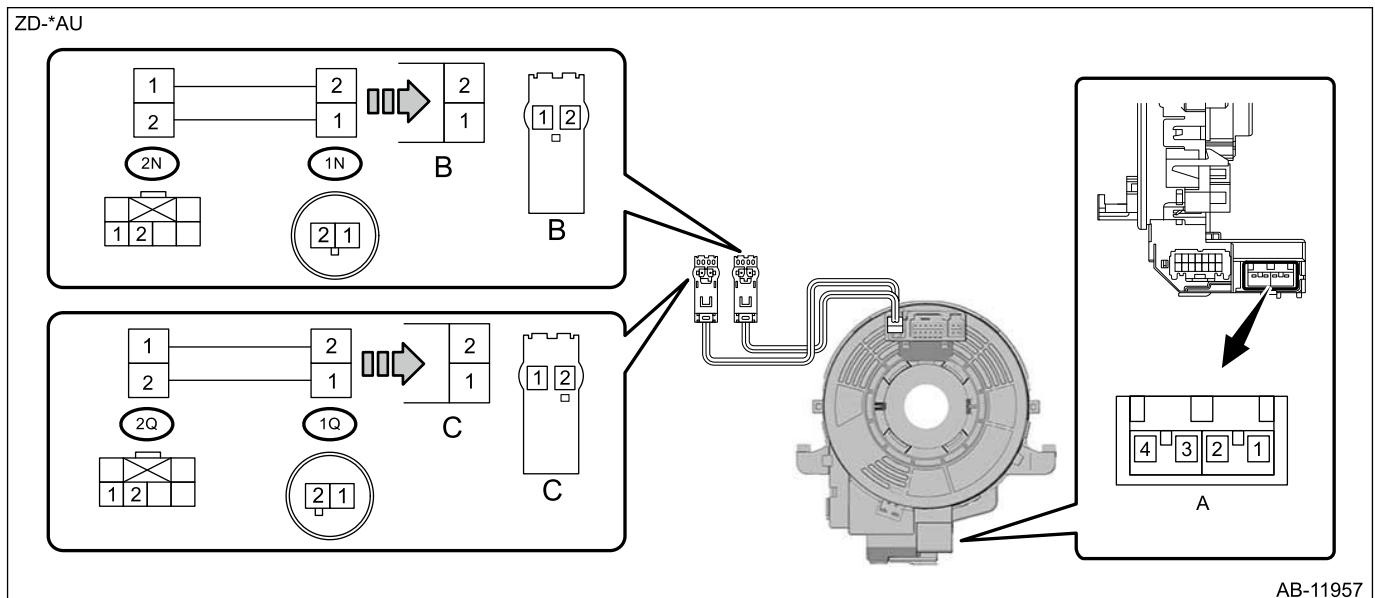

Terminal No.	Inspection conditions	Standard
(2N) No. 1 – (2N) No. 2	Always	Less than 1 Ω
(2Q) No. 1 – (2Q) No. 2	Always	Less than 1 Ω

5. Replace the steering roll connector if the inspection result is not within the standard value.

## ADJUSTMENT

### 1. NEUTRAL POSITION ADJUSTMENT

**Caution:**

- Do not rotate the steering roll connector to more than the specified number of turns. Otherwise, the roll connector internal wire may be broken.
- When determining the end stop, rotate the connector slowly without applying excessive force. Applying excessive force at the end stop may break the internal wire.

1. Check that front wheels are positioned in straight ahead direction.
2. Be sure to slowly rotate the steering roll connector counterclockwise until it stops.

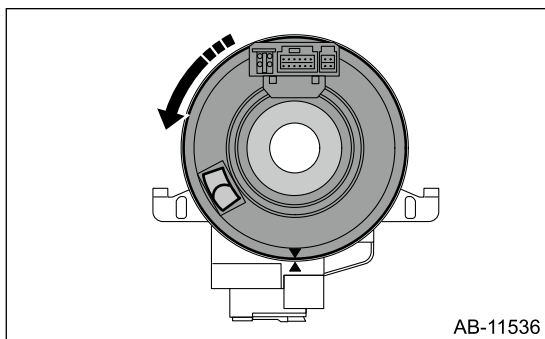

3. If the connector passes the lowermost position when it stops rotating, return the connector to the lowermost position.

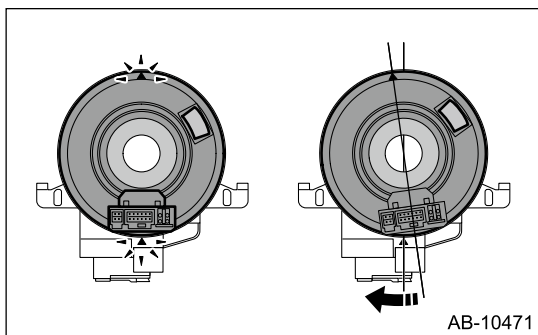

4. Make sure that the connector is at the lowermost position, and then rotate the steering roll connector clockwise by approx. 2.5 turns to return the connector to the uppermost position. The mark "▲" will be aligned.

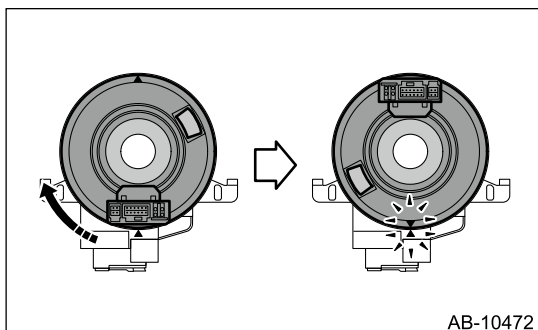

5. Check the following items to make sure that the steering roll connector is at the neutral position.

- The connector (a) is at the uppermost position.
- The alignment mark (b) is aligned.
- The top (c) of the flat cable U-turn section can be seen from the sight glass (d).

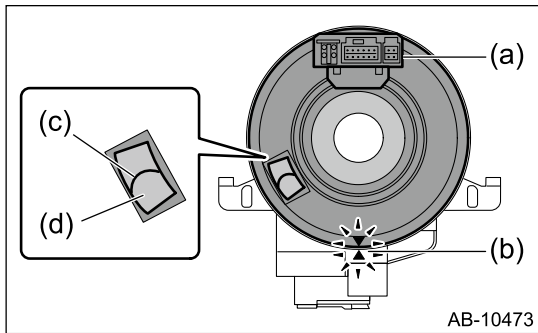



## AIRBAG SYSTEM > Airbag Module Disposal (Deployment Processing on Vehicle)

### PROCEDURE

#### Caution:

- Refer to "CAUTION" of "General Description" before handling the airbag system components.  [Ref. to AIRBAG SYSTEM>General Description>CAUTION.](#)
- Before discarding an airbag module, always perform an operation process to prevent any false activation.
- Wear protective gloves, safety goggles and earplugs during this operation. Wash your hands afterwards.
- Do not touch the airbag module just after activation because it is very hot. Before handling it for disposal, wait for 40 minutes.
- As a rule, perform an airbag module operation process while it is installed to the vehicle. Do not remove it unless necessary.
- Airbag module operation process should be performed on a flat place in safety area. Do not perform the process outdoors when there is rain or strong wind.
- Activating an airbag module causes a high explosive noise, be sure to warn people in the area, and do not allow anyone within 5 m (16 ft) radius of the disposal site.
- After activating the airbag module, smoke may arise. Therefore, it must be activated in a well-ventilated place with no smoke detector nearby.
- Do not expose the activated airbag module to water.
- Wrap the activated airbag module in a sealed vinyl bag when discarding.
- If it is impossible to perform an airbag module operation process due to some situational reasons, consult SUBARU dealership or one of the authorized workshops.

### 1. DRIVER'S AIRBAG MODULE

1. Turn the ignition switch to OFF.
2. Disconnect the ground terminal from the battery sensor, and wait for at least 60 seconds before starting work.  [Ref. to REPAIR CONTENTS>NOTE > BATTERY.](#)
3. Remove the column cover assembly.  [Ref. to POWER ASSISTED SYSTEM \(POWER STEERING\)>Steering\\_Column>REMOVAL.](#)
4. Disconnect the connector under the steering roll connector.  [Ref. to AIRBAG SYSTEM>Airbag Connector>PROCEDURE > STEERING ROLL CONNECTOR.](#)

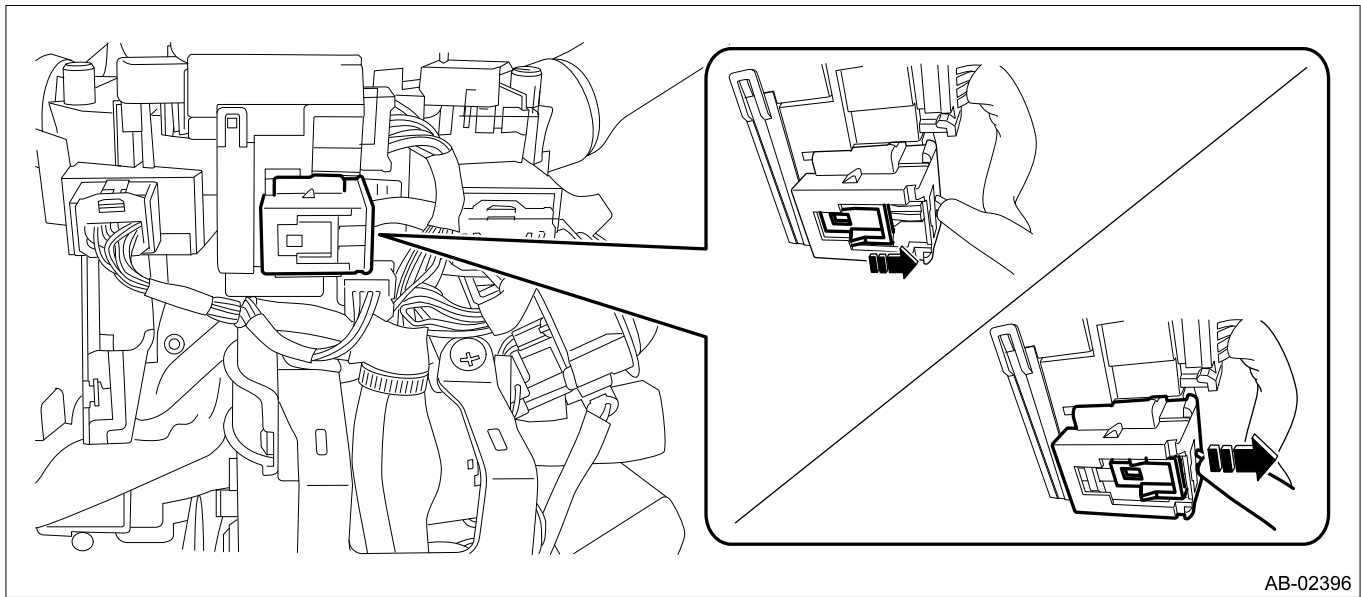

- 5.** Cut off the body harness approx. 70 mm (2.76 in) from the edge of the removed body side connector.

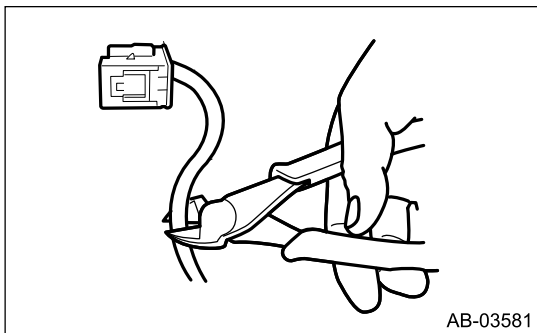

- 6.** Using a wire stripper or similar, peel off the shield (approx. 20 mm (0.79 in)) from the harnesses of the removed body side connector (at 4 locations).

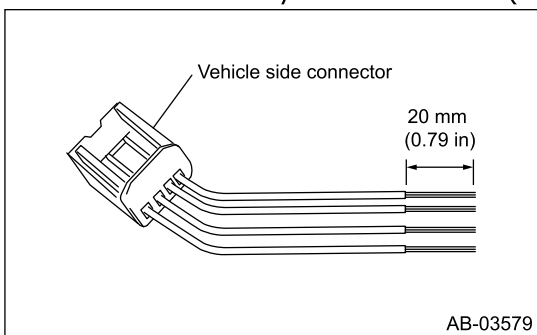

- 7.** Twist the end of harness as shown in the figure.

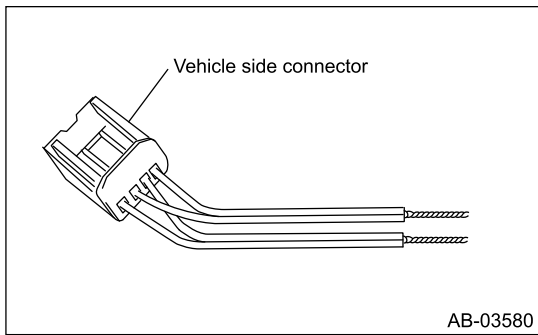

8. Prepare vinyl-shielded parallel wires of 6 m (19 ft) long. Peel off the ends of the shields of each wire approx. 20 mm (0.79 in), and fabricate one end of a wire into an alligator clip, and one end of the other wire into a terminal.
9. Short the terminal to the alligator clip.

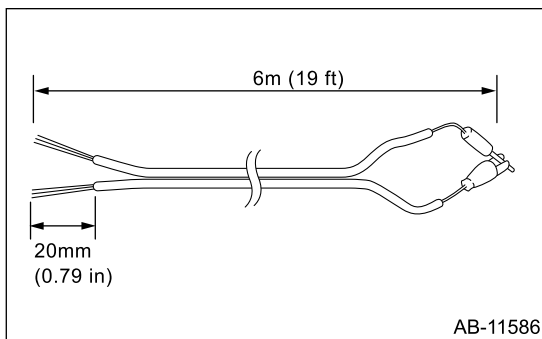

**Note:**  
**No concern about polarity.**

10. Connect the other end of each wire to the harnesses of the modified body connector as shown in the figure, and insulate them with vinyl tape.
11. After completing the connecting work, connect the body side connector to the connector of the airbag connector lower side again.

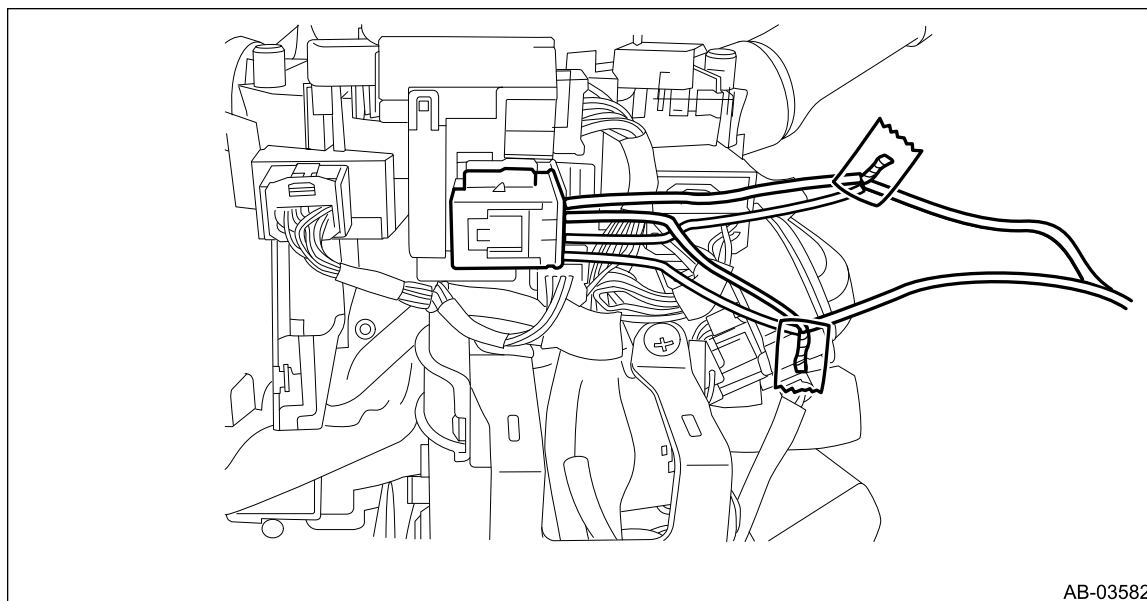

12. Bring the vinyl-shielded parallel wire for operation out of the vehicle, and make sure there is no person in the vehicle.

- 13.** Extend the vinyl-shielded parallel wire prepared in the previous procedure to the limit, and close all the windows and sunroof completely.

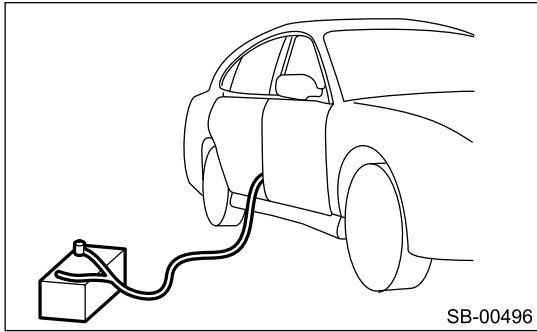

- 14.** Move the battery at least 5 m (16 ft) from the vehicle, and confirm safety in the area.  
**15.** Connect the alligator clip of vinyl-shielded parallel wire to the battery negative (-) terminal.  
**16.** Connect the other terminal of vinyl-shielded parallel wire to the battery positive (+) terminal, and activate the airbag module.

**Caution:**

- After activation, the airbag module will be extremely hot. Let it cool down for at least 40 minutes in an area with no one around.
- Do not expose the activated airbag module to water.

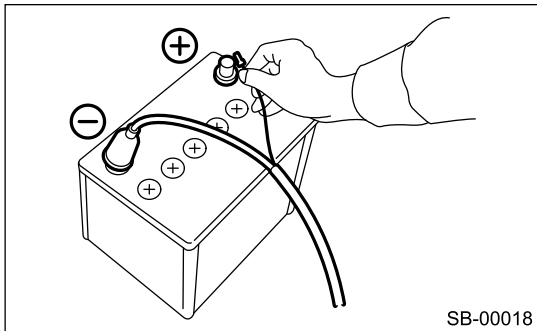

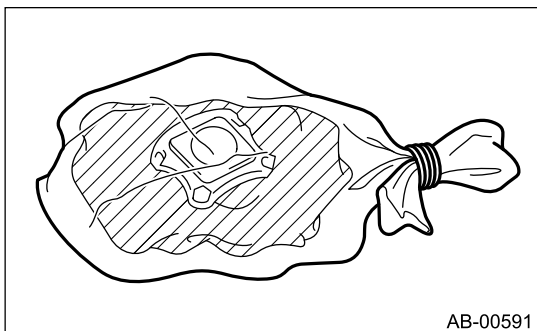

- 17.** Remove the driver's airbag module.  [Ref. to AIRBAG SYSTEM>Driver's Airbag Module>REMOVAL.](#)  
**18.** Place the activated airbag module in a sealed vinyl bag, then discard.



## 2. KNEE AIRBAG MODULE

- 1.** Turn the ignition switch to OFF.
- 2.** Disconnect the ground terminal from the battery sensor, and wait for at least 60 seconds before starting work.  [Ref. to REPAIR CONTENTS>NOTE > BATTERY.](#)

3. Remove the cover LWR driver.  [Ref. to EXTERIOR/INTERIOR TRIM>Instrument Panel Lower Cover>REMOVAL.](#)
4. Remove the knee airbag module.  [Ref. to AIRBAG SYSTEM>Knee Airbag Module>REMOVAL.](#)
5. Hold the knee airbag module using a vise, and bend the data link connector BRKT in the arrow direction.

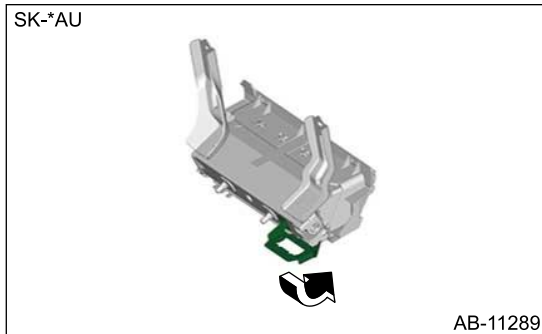

**Note:**

**Bend the data link connector BRKT to an extent that the connector of TEST HARNESS ADAPTER D does not contact.**

6. Activate the knee airbag module.

**Preparation tool:**

ST1: AIRBAG DEPLOYMENT TOOL (98299PA030)

ST2: TEST HARNESS ADAPTER D (98299SA010)

- (1) Short the terminal to the alligator clip furnished as ST1.

**Caution:**

**ST1 should be kept shorted on the terminals until just before activation of airbag module.**

- (2) Connect the ST1 with ST2.

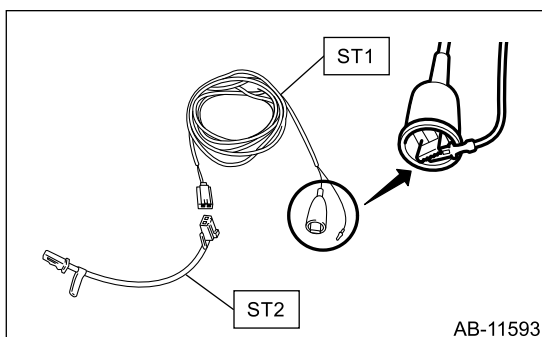

- (3) Connect the ST2 to the knee airbag module and install the knee airbag module to the vehicle again.

**Tightening torque:**

7.5 N·m (0.8 kgf·m, 5.5 ft-lb)

BWT\*BU

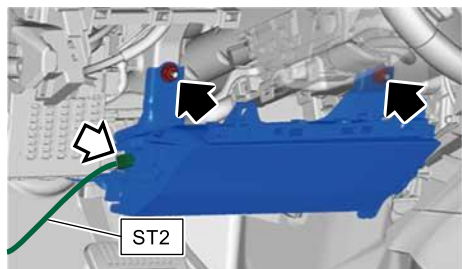

AB-11594

(4) Make sure there is no one inside the vehicle.

(5) Extend the wiring of ST1 to the limit, and close all the windows and sunroof completely.

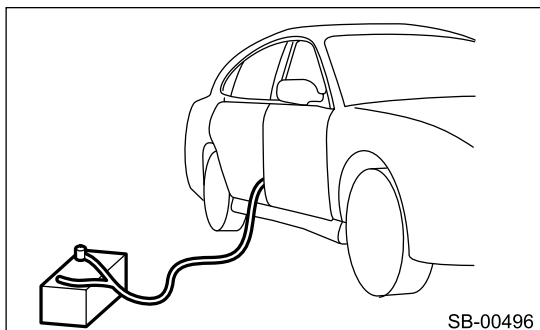

SB-00496

(6) Move the battery at least 5 m (16 ft) from the vehicle, and confirm safety in the area.

(7) Connect the ST1 alligator clip to the battery negative (–) terminal.

(8) Connect the other cable of ST1 to the battery positive (+) terminal, and activate the airbag module.

**Caution:**

- **After activation, the airbag module will be extremely hot. Let it cool down for at least 40 minutes in an area with no one around.**
- **Do not expose the activated airbag module to water.**

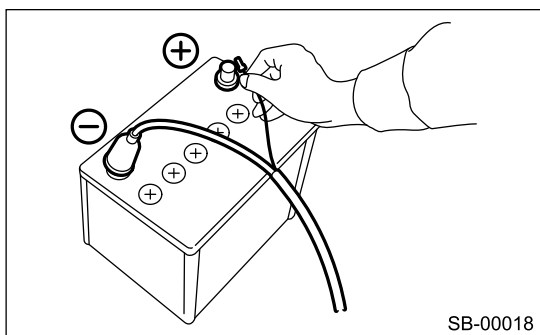

SB-00018

**7.** Remove the knee airbag module.  [Ref. to AIRBAG SYSTEM>Knee Airbag Module>REMOVAL.](#)



**8.** Place the activated airbag module in a sealed vinyl bag, then discard.

**Note:**

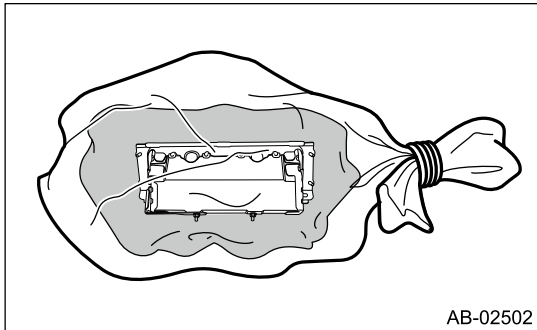
**When necessary, fold the fabric part of airbag into three or four sections, rope and seal in a vinyl bag.**



### 3. PASSENGER'S AIRBAG MODULE

1. Turn the ignition switch to OFF.
2. Disconnect the ground terminal from the battery sensor, and wait for at least 60 seconds before starting work.  [Ref. to REPAIR CONTENTS>NOTE > BATTERY.](#)
3. Remove the panel instrument passenger.  [Ref. to EXTERIOR/INTERIOR TRIM>Glove Box>REMOVAL > BACK PANEL.](#)
4. Disconnect the passenger's airbag module connector.  [Ref. to AIRBAG SYSTEM>Airbag Connector>PROCEDURE > PASSENGER'S AIRBAG MODULE, REAR SEAT BELT PRETENSIONER, FRONT SEAT BELT PRETENSIONER & ADAPTIVE FORCE LIMITER.](#)
5. Operate the passenger's airbag module.

#### Preparation tool:

ST1: AIRBAG DEPLOYMENT TOOL (98299PA030)

ST2: TEST HARNESS ADAPTER AM (98299FJ000)

- (1) Prepare two ST1s and short the terminal to the alligator clip furnished.

#### Caution:

**ST1 should be kept shorted on the terminals until just before activation of airbag module.**

- (2) Connect the ST1 with ST2.

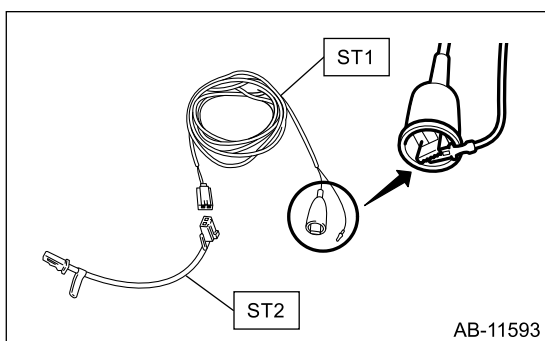

- (3) Connect ST2 to the airbag connector.

VBN\*BU

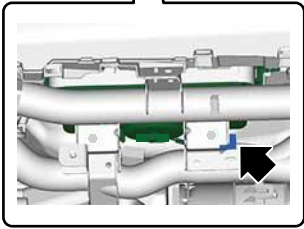
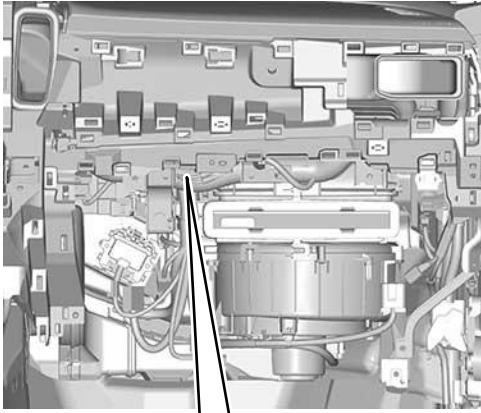

AB-12025

- (4) Make sure there is no one inside the vehicle.
- (5) Extend the wiring of ST1 to the limit, and close all the windows and sunroof completely.

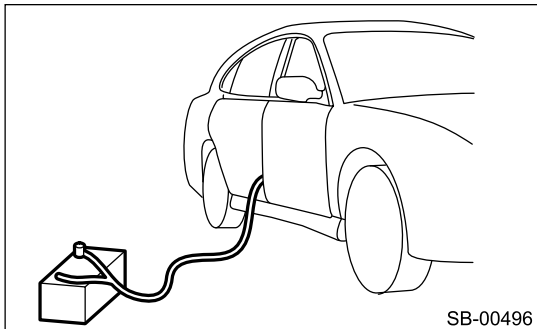



SB-00496

- (6) Move the battery at least 5 m (16 ft) from the vehicle, and confirm safety in the area.
- (7) Connect the ST1 alligator clip to the battery negative (-) terminal.
- (8) Connect the other cable of ST1 to the battery positive (+) terminal, and activate the airbag module.

**Caution:**

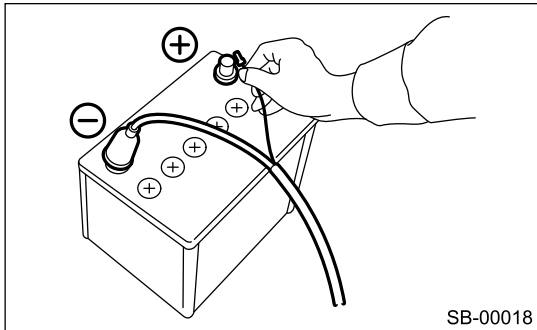
- **After activation, the airbag module will be extremely hot. Let it cool down for at least 40 minutes in an area with no one around.**
- **Do not expose the activated airbag module to water.**



6. Remove the passenger's airbag module.  [Ref. to AIRBAG SYSTEM>Passenger's Airbag Module>REMOVAL.](#)
7. Place the activated airbag module in a sealed vinyl bag, then discard.

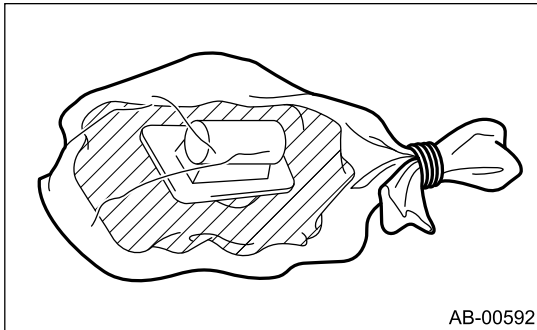

#### 4. SIDE AIRBAG MODULE

1. Turn the ignition switch to OFF.
2. Disconnect the ground terminal from the battery sensor, and wait for at least 60 seconds before starting work.  [Ref. to REPAIR CONTENTS>NOTE > BATTERY.](#)
3. Remove the bolts that secure the front seat.

**Note:**

**For models with power seat, remove the slide rail installing bolt before disconnecting the ground terminal from the battery sensor.**

4. Disconnect the side airbag module connector under the front seat cushion.  [Ref. to AIRBAG SYSTEM>Airbag Connector>PROCEDURE > SIDE AIRBAG MODULE.](#)
5. Activate the side airbag module.

**Preparation tool:**

ST1: AIRBAG DEPLOYMENT TOOL (98299PA030)

ST2: TEST HARNESS ADAPTER AR (98299CA000)

- (1) Short the terminal to the alligator clip furnished as ST1.

**Caution:**

**ST1 should be kept shorted on the terminals until just before activation of airbag module.**

- (2) Connect the ST1 with ST2.

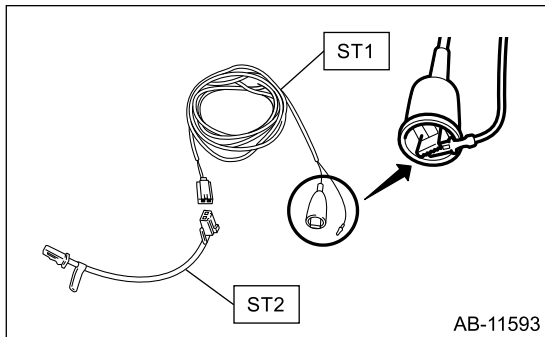

(3) Connect ST2 to the side airbag module connector.

**Caution:**

**Do not place any object on front seat.**

(4) Tighten the front seat to the specified torque.

**Tightening torque:**

Front seat assembly: 53 N·m (5.4 kgf-m, 39.1 ft-lb)

(5) Make sure there is no one inside the vehicle.

(6) Extend the wiring of ST1 to the limit, and close all the windows and sunroof completely.

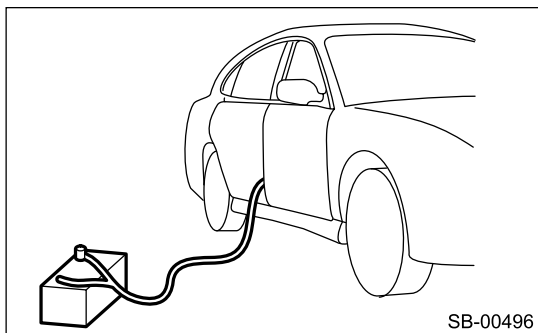

(7) Move the battery at least 5 m (16 ft) from the vehicle, and confirm safety in the area.

(8) Connect the ST1 alligator clip to the battery negative (-) terminal.

(9) Connect the other cable of ST1 to the battery positive (+) terminal, and activate the airbag module.

**Caution:**

- After activation, the airbag module will be extremely hot. Let it cool down for at least 40 minutes in an area with no one around.
- Do not expose the activated airbag module to water.

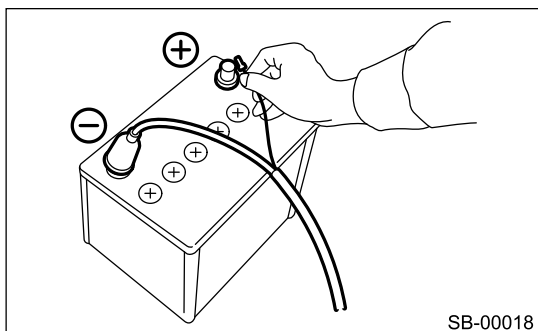

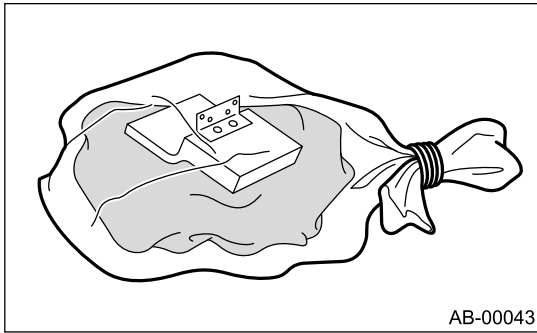

**6.** Remove the side airbag module.  [Ref. to AIRBAG SYSTEM>Side Airbag Module>REMOVAL.](#)

**7.** Place the activated airbag module in a sealed vinyl bag, then discard.



## 5. CURTAIN AIRBAG MODULE

1. Turn the ignition switch to OFF.
2. Disconnect the ground terminal from the battery sensor, and wait for at least 60 seconds before starting work.  [Ref. to REPAIR CONTENTS>NOTE > BATTERY.](#)
3. Remove the trim panel roof assembly.  [Ref. to EXTERIOR/INTERIOR TRIM>Roof Trim>REMOVAL.](#)
4. Disconnect the curtain airbag module connector.  [Ref. to AIRBAG SYSTEM>Airbag Connector>PROCEDURE > CURTAIN AIRBAG MODULE.](#)
5. Activate the curtain airbag module.

### Preparation tool:

ST1: AIRBAG DEPLOYMENT TOOL (98299PA030)

ST2: TEST HARNESS ADAPTER D (98299SA010)

- (1) Short the terminal to the alligator clip furnished as ST1.

### Caution:

**ST1 should be kept shorted on the terminals until just before activation of airbag module.**

- (2) Connect the ST1 with ST2.

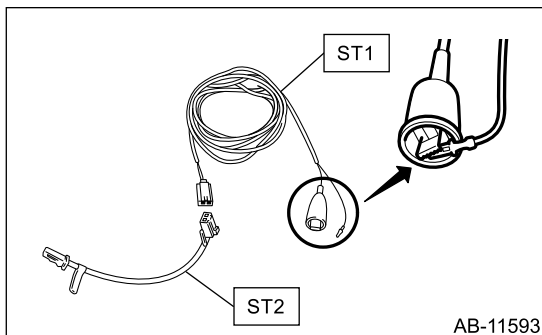

- (3) Connect the ST2 to the curtain airbag module.

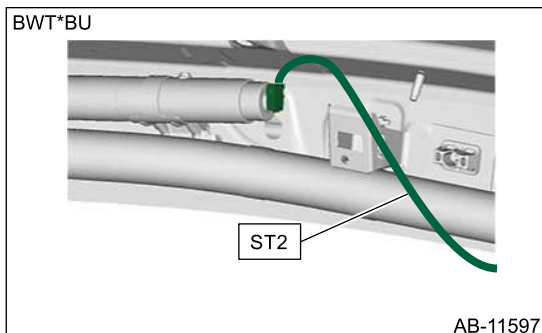

- (4) Make sure there is no one inside the vehicle.
- (5) Extend the wiring of ST1 to the limit, and close all the windows and sunroof completely.

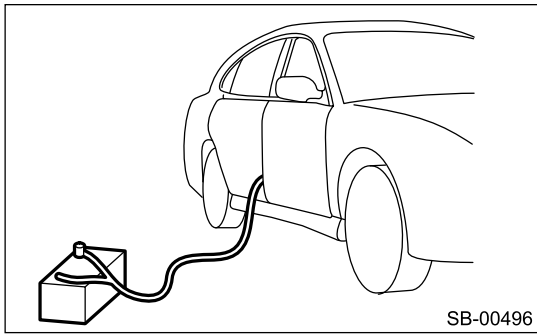

- (6) Move the battery at least 5 m (16 ft) from the vehicle, and confirm safety in the area.
- (7) Connect the ST1 alligator clip to the battery negative (-) terminal.
- (8) Connect the other cable of ST1 to the battery positive (+) terminal, and activate the airbag module.

**Caution:**

- After activation, the airbag module will be extremely hot. Let it cool down for at least 40 minutes in an area with no one around.
- Do not expose the activated airbag module to water.

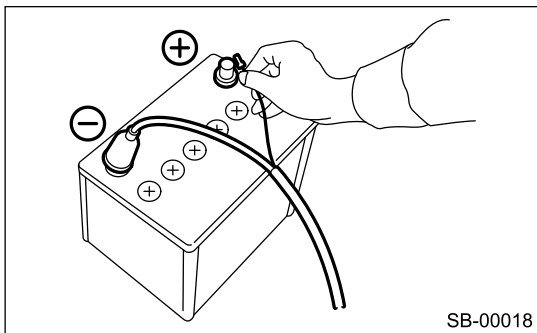

6. Remove the curtain airbag module.  [Ref. to AIRBAG SYSTEM>Curtain Airbag Module>REMOVAL.](#)
7. Place the activated airbag module in a sealed vinyl bag, then discard.

**Note:**

**When necessary, fold the fabric part of airbag into three or four sections, rope and seal in a vinyl bag.**

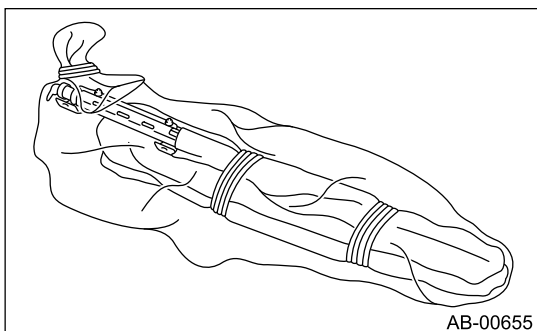

# SEAT BELT SYSTEM

**SB**

- 
1. General Description
  2. Pretensioner Connector
  3. Inspection Locations after a Collision
  4. Seat Belt Warning System
  5. Front Seat Belt
  6. Rear Seat Belt
  7. Disposal of Pretensioner

## SEAT BELT SYSTEM > General Description

### CAUTION

---

For details of the following precautions for seat belt pretensioner, refer to "AIRBAG SYSTEM" section.

[Ref. to AIRBAG SYSTEM>General Description>CAUTION.](#)

- When performing service operation, refer to "Repair Contents" in "General Description". [Ref. to REPAIR CONTENTS>Repair Contents.](#)
- Before performing vehicle maintenance, turn the ignition switch to OFF, and wait for 60 seconds or more after disconnecting the ground terminal from the battery sensor. [Ref. to REPAIR CONTENTS>NOTE > BATTERY.](#)
- Do not drop or apply any impact to the pretensioner.
- Do not allow oil, grease or water to come in contact with the pretensioner.
- Do not expose the pretensioner to high temperature or flame.
- Do not allow current to flow through or voltage to reach the pretensioner. Do not use a circuit tester to check resistance of the pretensioner.
- Do not disassemble or attempt to repair the pretensioner. If it is dented, cracked or deformed, replace it with a new genuine part.
- Do not use the airbag or pretensioner parts from other vehicles. Always replace parts with new genuine parts.
- When handling a seat belt with deployed pretensioner, wear gloves and goggles. Wash your hands afterwards.
- Do not reuse a seat belt with deployed pretensioner.
- Before disposal, make sure to perform an operation process to the pretensioners. [Ref. to SEAT BELT SYSTEM>Disposal of Pretensioner>PROCEDURE.](#)
- If material enters the eyes or contacts skin during operation process, wash it away with clean water, and then consult a doctor.

## SEAT BELT SYSTEM > General Description

### COMPONENT

---

# 1. FRONT SEAT BELT

(1) Adjuster shoulder anchor	(5) Spring wave washer	<b><i>Tightening torque: N-m (kgf-m, ft-lb)</i></b>
(2) Belt ASSY front OUT RH	(6) Belt ASSY front INN LH*	<b><i>T1: 7.5 (0.8, 5.5)</i></b>
(3) Cover shoulder anchor	(7) Belt ASSY front OUT LH	<b><i>T2: 30 (3.1, 22.1)</i></b>
(4) Belt ASSY front INN RH*		<b><i>T3: 38 (3.9, 28.0)</i></b>
		<b><i>T4: 53 (5.4, 39.1)</i></b>

\*: Apply grease when replacing the belt assembly front INN. [Ref. to SEAT BELT SYSTEM>Front Seat Belt>INSTALLATION > BELT ASSEMBLY FRONT INN.](#)

## 2. REAR SEAT BELT

- |                                  |                            |
|----------------------------------|----------------------------|
| (1) Belt ASSY rear OUT RH        | (4) Cover CTR ELR          |
| (2) Belt ASSY rear INN center LH | (5) Belt ASSY rear OUT CTR |
| (3) Belt ASSY rear OUT LH        | (6) Belt cover             |

**Tightening torque: N-m (kgf-m, ft-lb)**

**T1: 30 (3.1, 22.1)**

**T2: 53 (5.4, 39.1)**

**T3: Ref. to SEAT BELT SYSTEM>Rear Seat Belt>INSTALLATION > BELT ASSEMBLY REAR OUT RH AND LH.**

### SEAT BELT SYSTEM > General Description

#### INSPECTION

---

For inspection of seat belt pretensioner and lap pretensioner, refer to the followings.

#### 1. BASIC INSPECTION

For basic inspection, refer to "Basic Diagnostic Procedure" of "AIRBAG (DIAGNOSTICS)" section. [Ref. to AIRBAG\(DIAGNOSTICS\)>Basic Diagnostic Procedure.](#)

#### 2. SYSTEM BLOCK DIAGRAM

For system block diagram, refer to "System Block Diagram" in "AIRBAG (DIAGNOSTICS)" section. [Ref. to AIRBAG\(DIAGNOSTICS\)>General Description>SYSTEM BLOCK DIAGRAM.](#)

### 3. MODULE I/O SIGNAL

For the specification (electrical component), refer to "Control Module I/O Signal" of "AIRBAG (DIAGNOSTICS)" section. [Ref. to AIRBAG\(DIAGNOSTICS\)>Control Module I/O Signal.](#)

#### SEAT BELT SYSTEM > General Description

#### PREPARATION TOOL

---

#### 1. SUBARU SPECIAL TOOL

ILLUSTRATION	TOOL NUMBER	DESCRIPTION	REMARKS
	—	SUBARU SELECT MONITOR 4	Used for setting of each function and troubleshooting for electrical system. <b>Note:</b> <ul style="list-style-type: none"><li>• For detailed operation procedures, refer to "Help" of application.</li><li>• Used together with interface for Subaru Select Monitor (such as DST-i and DST-010).</li></ul>
	98299SA010	TEST HARNESS ADAPTER D	<ul style="list-style-type: none"><li>• Used for operation process of front pretensioner.</li><li>• Used for operation process of adaptive force limiter.</li><li>• Used together with AIRBAG DEPLOYMENT TOOL. (98299PA030)</li></ul>
	98299SA050	TEST HARNESS ADAPTER F	<ul style="list-style-type: none"><li>• Used for operation process of lap seat belt pretensioner.</li><li>• Used together with AIRBAG DEPLOYMENT TOOL. (98299PA030)</li></ul>

ILLUSTRATION	TOOL NUMBER	DESCRIPTION	REMARKS
	98299FJ000	TEST HARNESS ADAPTER AM	<ul style="list-style-type: none"> <li>• Used for operation process of rear pretensioner.</li> <li>• Used together with AIRBAG DEPLOYMENT TOOL. (98299PA030)</li> </ul>
	98299PA030	AIRBAG DEPLOYMENT TOOL	<ul style="list-style-type: none"> <li>• Used for operation process of pretensioner.</li> <li>• Used together with each test harness adapter.</li> </ul>

## 2. OTHER

	REMARKS
Circuit tester	Used for measuring resistance, voltage and current.

## SEAT BELT SYSTEM > Pretensioner Connector

### NOTE

---

For connectors of front seat belt pretensioner & adaptive force limiter, lap seat belt pretensioner (passenger's side), rear seat belt pretensioner and passenger's seat buckle switch, refer to "Airbag Connector" of the "AIRBAG SYSTEM" section. [Ref. to AIRBAG SYSTEM>Airbag\\_Connector>PROCEDURE.](#)

## SEAT BELT SYSTEM > Inspection Locations after a Collision

### INSPECTION

---

For inspection locations after a collision, refer to "Inspection Locations after a Collision" of the "AIRBAG SYSTEM" section. [\\_Ref. to AIRBAG SYSTEM>Inspection Locations after a Collision.](#)

## SEAT BELT SYSTEM > Seat Belt Warning System

### WIRING DIAGRAM

---

For the wiring diagram, refer to "Seat Belt Warning System" in the wiring diagram. [Ref. to WIRING SYSTEM>Seat Belt Warning System>WIRING DIAGRAM.](#)

## SEAT BELT SYSTEM > Seat Belt Warning System

### INSPECTION

---

#### Caution:

- **Before handling the airbag system components, refer to "CAUTION" of "General Description" in "AIRBAG SYSTEM". [Ref. to AIRBAG SYSTEM>General Description>CAUTION.](#)**
- **When inspecting the airbag main harness, disconnect the connectors of the driver's airbag module, passenger's airbag module and knee airbag module for safety reasons.**
- **When inspecting the airbag rear harness, disconnect the side airbag module connector, curtain airbag module connector and seat belt pretensioner connector for safety reasons.**

#### Trouble symptom:

- Seat belt warning light for each seat does not illuminate (blink) or it remains illuminating (blinking).
- Warning buzzer does not beep.

### 1. CHECK DRIVER'S SEAT BELT WARNING LIGHT

1. Turn the ignition switch to ON.
2. Sit on the driver's seat, and check that the driver's seat belt warning light in the combination meter assembly blinks when the seat belt tongue plate is not inserted in the buckle.
3. While sitting on the driver's seat, check that the driver's seat belt warning light in the combination meter assembly turns off when the seat belt tongue plate is inserted in the buckle.

### 2. CHECK PASSENGER'S SEAT BELT WARNING LIGHT

1. Turn the ignition switch to ON.
2. Sit on the passenger's seat, and check that the passenger's seat belt warning light in the warning box blinks when the seat belt tongue plate is not inserted in the buckle.
3. While sitting the passenger's seat, check that the passenger's seat belt warning light in the warning box turns off when the seat belt tongue plate is inserted in the buckle.

### 3. CHECK REAR SEAT BELT WARNING LIGHT

1. Turn the ignition switch to ON.
2. Sit on the rear seat and check that all rear seat belt warning lights in the warning box turn on when the seat belt tongue plates are not inserted in the buckle.
3. Sit on the rear seat and check that the corresponding rear seat belt warning light in the warning box turns off when each seat belt tongue plate is inserted in the buckle.

### 4. CHECK DRIVER'S SEAT BELT WARNING BUZZER

1. Lift up the vehicle.
2. Turn the ignition switch to ON and start the engine.

3. Drive the vehicle at 20 km/h (12 MPH) or more while the driver's seat belt tongue plate is not inserted in the buckle. Check that the buzzer in the combination meter sounds intermittently for approx. 110 seconds and the warning light turns on (blinks).
4. Turn the ignition switch to OFF when the buzzer stops, and start the engine again. Check that the buzzer sounds again by driving the vehicle at 20 km/h (12 MPH) or more while the seat belt tongue plate is not inserted in the buckle.
5. Insert the seat belt tongue plate in the buckle when the buzzer stops, and drive the vehicle at 20 km/h (12 MPH) or more. Check that the buzzer sounds again when the seat belt is unfastened.
6. After stopping the buzzer, set the shift position to "R" and then set it to "D" (CVT model) or a position other than "R" (MT model). Check that the buzzer sounds again by driving the vehicle at 20 km/h (12 MPH) or more while the seat belt tongue plate is not inserted in the buckle.

## **5. CHECK PASSENGER'S SEAT BELT WARNING BUZZER**

1. Lift up the vehicle.
2. Turn the ignition switch to ON and start the engine.
3. Insert the driver's seat belt tongue plate in the buckle.
4. Sit on the passenger's seat and drive the vehicle at 20 km/h (12 MPH) or more while the passenger's seat belt tongue plate is not inserted in the buckle. Check that the buzzer in the combination meter sounds intermittently for approx. 110 seconds and the warning light turns on (blinks).
5. Turn the ignition switch to OFF when the buzzer stops, and start the engine again. Check that the buzzer sounds again by driving the vehicle at 20 km/h (12 MPH) or more while the seat belt tongue plate is not inserted in the buckle.
6. Insert the seat belt tongue plate in the buckle when the buzzer stops, and drive the vehicle at 20 km/h (12 MPH) or more. Check that the buzzer sounds again when the seat belt is unfastened.
7. After stopping the buzzer, set the shift position to "R" and then set it to "D" (CVT model) or a position other than "R" (MT model). Check that the buzzer sounds again by driving the vehicle at 20 km/h (12 MPH) or more while the seat belt tongue plate is not inserted in the buckle.

## **6. CHECK REAR SEAT BELT WARNING BUZZER**

1. Lift up the vehicle.
2. Turn the ignition switch to ON and start the engine.
3. Insert the driver's seat belt tongue plate in the buckle.
4. Sit on the corresponding rear seat and then drive the vehicle at 20 km/h (12 MPH) or more while the seat belt tongue plate is not inserted in the buckle. Check that the buzzer in the combination meter sounds intermittently for approx. 35 seconds and the warning light blinks.
5. Turn the ignition switch to OFF when the buzzer stops, and start the engine again. Check that the buzzer sounds again by driving the vehicle at 20 km/h (12 MPH) or more while the seat belt tongue plate is not inserted in the buckle.
6. Insert the seat belt tongue plate in the buckle when the buzzer stops, and drive the vehicle at 20 km/h (12 MPH) or more. Check that the buzzer sounds again when the seat belt is unfastened.
7. After stopping the buzzer, set the shift position to "R" and then set it to "D" (CVT model) or a position other than "R" (MT model). Check that the buzzer sounds again by driving the vehicle at 20 km/h (12 MPH) or more while the seat belt tongue plate is not inserted in the buckle.

## **7. DRIVER'S SEAT BELT WARNING LIGHT DOES NOT ILLUMINATE**

**Wiring diagram:**

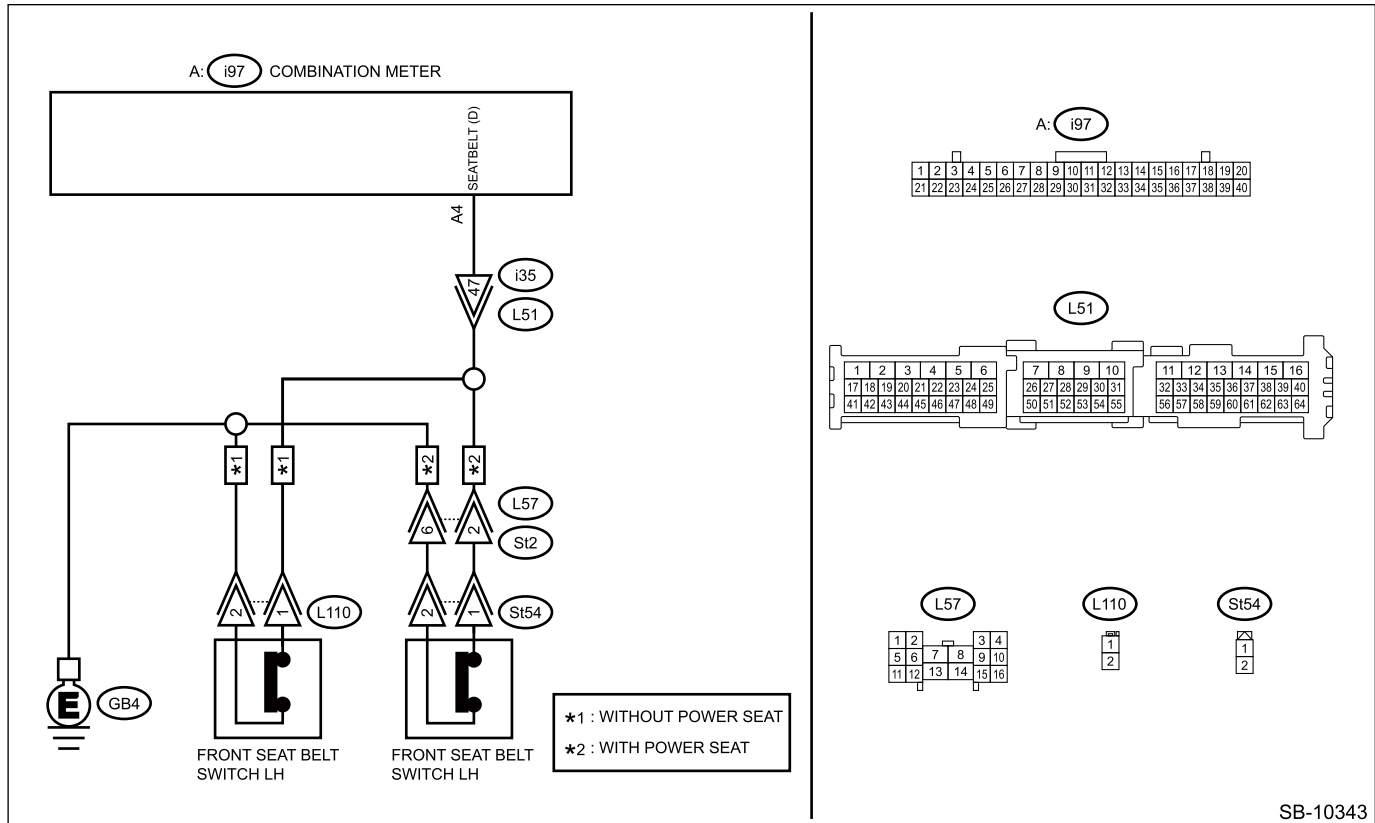

SB-10343

## 1. CHECK FUNCTION.

1. Turn the ignition switch to ON.
2. Using the Subaru Select Monitor, perform the [Driver side seat belt] function check using the [Active Test] of [Combination Meter]. [Ref. to COMBINATION METER \(DIAGNOSTICS\)>Active Test.](#)

Does the driver's seat belt warning light illuminate (blink) or go off?

Yes

[Go to 2.](#)

No

Replace the combination meter assembly. [Ref. to INSTRUMENTATION/DRIVER INFO>Combination Meter.](#)

## 2. CHECK DRIVER'S SEAT BELT BUCKLE SWITCH.

1. Turn the ignition switch to OFF.
2. Perform unit inspection for driver's seat belt buckle switch. [Ref. to SEAT BELT SYSTEM>Front Seat Belt>INSPECTION.](#)

Is the check result OK?

 Yes

[Go to 3.](#)

 No

Replace the belt assembly front INN RH. [Ref. to SEAT BELT SYSTEM>Front Seat Belt.](#)

## 3. CHECK HARNESS.

1. Disconnect the combination meter connector and the driver's seat belt buckle switch connector.
2. Check for short circuit to battery, open circuit and short circuit to ground between the combination meter and the driver's seat belt buckle switch.

### Connector & terminal

#### Except for model with power seat

(L110) No. 1 — (i97) No. 4:

#### Model with power seat

(St54) No. 1 — (i97) No. 4:

Is harness normal?

 Yes

[Go to 4.](#)

 No

Repair or replace the defective part.

#### 4. CHECK HARNESS.

Measure the resistance between the driver's seat belt buckle switch connector and chassis ground.

##### Connector & terminal

##### Except for model with power seat

(L110) No. 2 — Chassis ground:

##### Model with power seat

(St54) No. 2 — Chassis ground:

Is harness normal?

Yes

Replace the combination meter assembly. [Ref. to INSTRUMENTATION/DRIVER INFO>Combination Meter.](#)

No

Repair or replace the defective part.

#### 8. PASSENGER'S SEAT BELT WARNING LIGHT DOES NOT ILLUMINATE

##### Wiring diagram:

Seat belt warning system [Ref. to WIRING SYSTEM>Seat Belt Warning\\_System>WIRING DIAGRAM.](#)

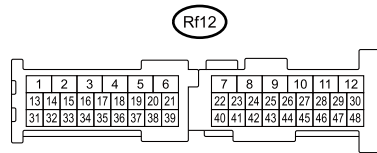
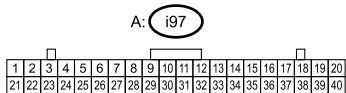
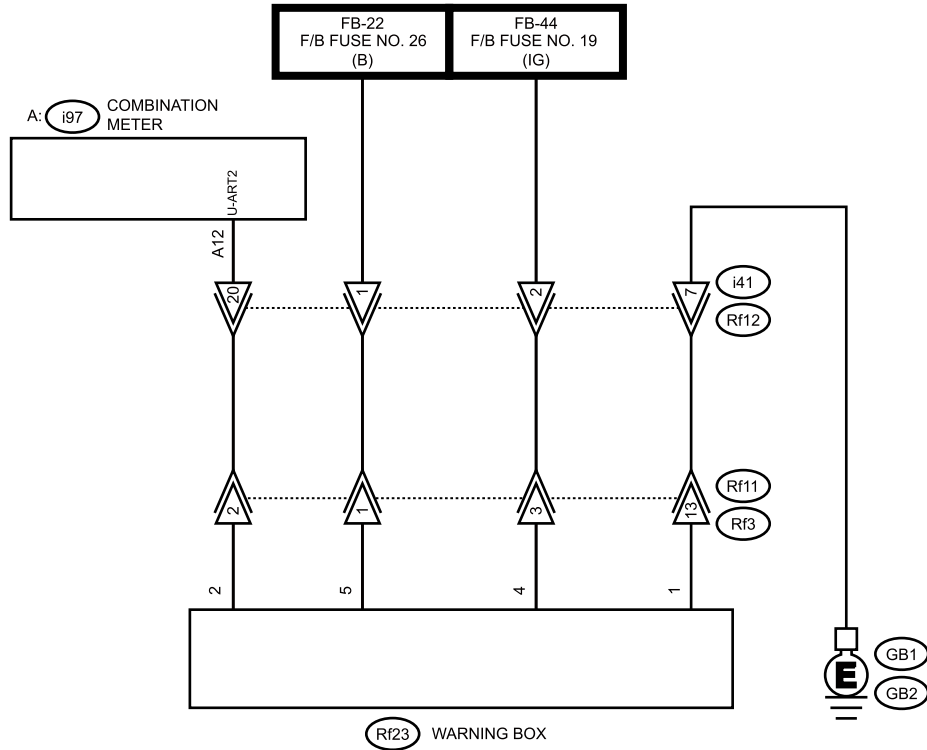

SB-10344

## 1. CHECK FUNCTION.

1. Sit on the passenger's seat and disconnect the seat belt.
2. Turn the ignition switch to ON (engine OFF).
3. Fasten and detach the passenger's seat belt buckle.

Does the seat belt warning light display vary according to the operation of the seat belt buckle?

Yes

It may be a temporary poor contact. Check the contacting condition of harness and connector.

No

[Go to 2.](#)

## 2. CHECK DATA MONITOR.

1. Using Subaru Select Monitor, display [Passenger side seat belt state] in [Data monitor] of [Combination Meter]. [Ref. to COMMON \(DIAGNOSTICS\)>Data Monitor.](#)
2. Fasten and detach the passenger's side seat belt buckle, and read the data of the seat belt switch.

Does the display vary according to the operation of the seat belt buckle?

Yes

[Go to 5.](#)

No

[Go to 3.](#)

## 3. CHECK DTC.

Using the Subaru Select Monitor, read all DTCs. [Ref. to LAN SYSTEM \(DIAGNOSTICS\)>Diagnostic Trouble Code \(DTC\).](#)

Is DTC displayed?

Yes

Perform the diagnosis for the displayed DTCs.

No

[Go to 4.](#)

## 4. CHECK AIRBAG CONTROL MODULE AND COMBINATION METER.

Inspect LAN system. [Ref. to LAN SYSTEM \(DIAGNOSTICS\)>Basic Diagnostic Procedure>PROCEDURE.](#)

Is the check result OK?

Yes

[Go to 5.](#)

No

Follow the diagnostic procedure and repair or replace the defective part.

## 5. CHECK WARNING BOX POWER SUPPLY VOLTAGE.

1. Turn the ignition switch to OFF.
2. Disconnect the warning box connector.
3. Turn the ignition switch to ON.
4. Measure the voltage between the warning box connector and chassis ground.

### Connector & terminal

(Rf23) No. 5 (+) — Chassis ground (-):

(Rf23) No. 4 (+) — Chassis ground (-):

Is the voltage 10 V or more?

 Yes

[Go to 6.](#)

 No

Repair or replace the defective part.

## 6. CHECK WARNING BOX GROUND CIRCUIT.

1. Turn the ignition switch to OFF.
2. Measure the resistance between the warning box connector and chassis ground.

### Connector & terminal

(Rf23) No. 1 — Chassis ground:

Is the resistance less than 10  $\Omega$ ?

 Yes

[Go to 7.](#)

 No

Repair or replace the defective part.

## 7. CHECK HARNESS BETWEEN WARNING BOX AND COMBINATION METER.

1. Disconnect the connector of combination meter.
2. Measure the resistance between warning box and combination meter.

### Connector & terminal

(Rf23) No. 2 — (i97) No. 12:

Is the resistance less than 10  $\Omega$ ?

Yes

[Go to 8.](#)

No

Repair or replace the defective part.

## 8. CHECK WARNING BOX AND COMBINATION METER.

1. Remove the warning box, and install a properly operating warning box (new warning box).
2. Connect the connector and then turn the ignition switch to ON.

Is the warning box properly displayed?

Yes

Replace the warning box. [Ref. to INSTRUMENTATION/DRIVER INFO>Warning Box.](#)

No

Replace the combination meter assembly. [Ref. to INSTRUMENTATION/DRIVER INFO>Combination Meter.](#)

## 9. REAR SEAT BELT WARNING LIGHT DOES NOT ILLUMINATE

### Wiring diagram:

Seat belt warning system [Ref. to WIRING SYSTEM>Seat Belt Warning System>WIRING DIAGRAM.](#)

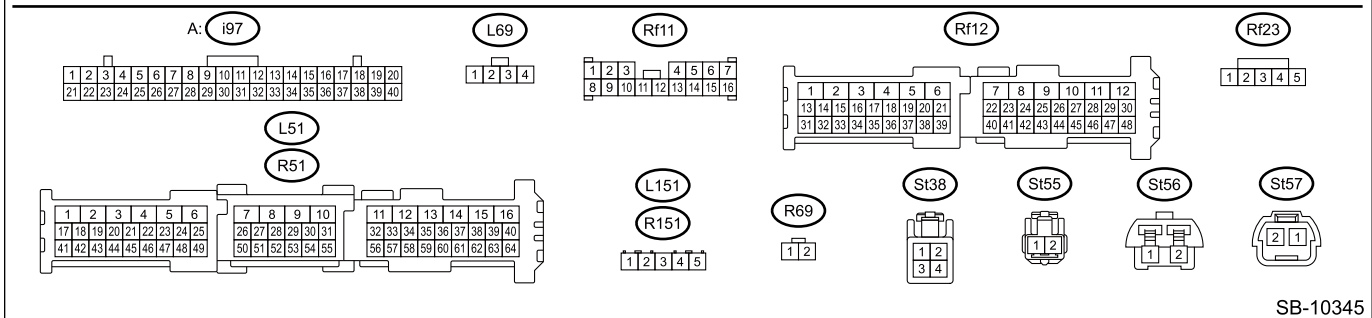
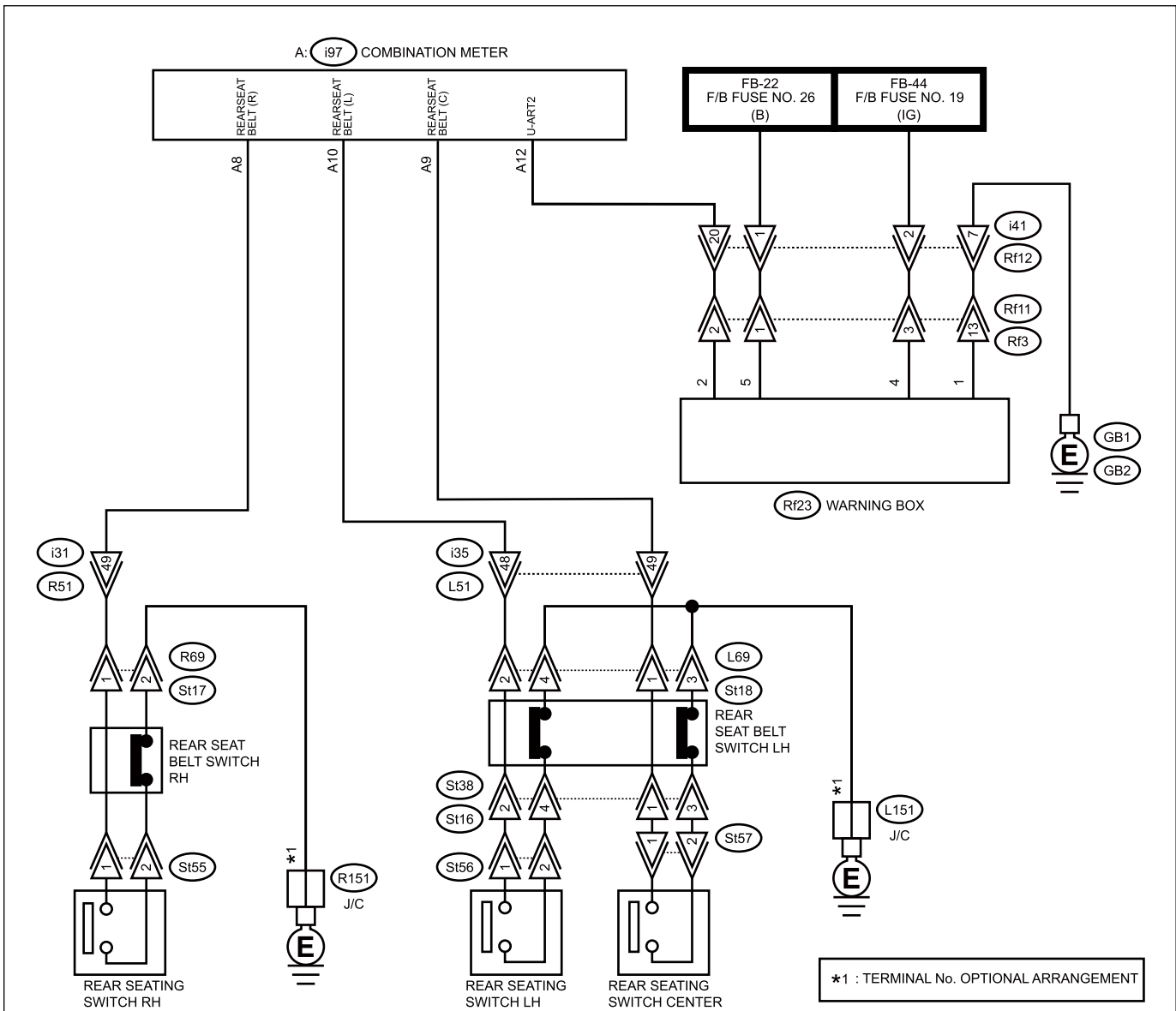

## 1. CHECK FUNCTION.

1. Sit on each rear seat position and disconnect the seat belt.
2. Turn the ignition switch to ON (engine OFF).
3. Fasten and detach the rear seat belt buckle.

Does the rear seat belt warning light illuminate or go off?

Yes

It may be a temporary poor contact. Check the contacting condition of harness and connector.

No

[Go to 2.](#)

## 2. CHECK DATA MONITOR.

1. Using the Subaru Select Monitor, display the following items in the [Data monitor] of [Combination Meter]. [Ref. to COMMON \(DIAGNOSTICS\)>Data Monitor.](#)
  - [Rear side (right) seat belt state]
  - [Rear side (center) seatbelt state]
  - [Rear side (left) seat belt state]
2. Fasten and detach the rear seat belt buckle at each position, and read the data of the seat belt switch.

Does the display vary according to the operation of the seat belt buckle?

Yes

It may be a temporary poor contact. Check the contacting condition of harness and connector.

No

[Go to 3.](#)

### 3. CHECK WARNING BOX POWER SUPPLY CIRCUIT.

1. Turn the ignition switch to OFF.
2. Disconnect the warning box connector.
3. Turn the ignition switch to ON.
4. Measure the voltage between the warning box connector and chassis ground.

#### Connector & terminal

(Rf23) No. 5 (+) — Chassis ground (-):

(Rf23) No. 4 (+) — Chassis ground (-):

Is the voltage 10 V or more?

 Yes

[Go to 4.](#)

 No

Repair or replace the defective part.

### 4. CHECK WARNING BOX GROUND CIRCUIT.

1. Turn the ignition switch to OFF.
2. Measure the resistance between the warning box connector and chassis ground.

#### Connector & terminal

(Rf23) No. 1 — Chassis ground:

Is the resistance less than 10  $\Omega$ ?

 Yes

[Go to 5.](#)

 No

Repair or replace the defective part.

## 5. CHECK HARNESS BETWEEN WARNING BOX AND COMBINATION METER.

1. Disconnect the harness of the combination meter.
2. Measure the resistance between the warning box connector and combination meter.

### Connector & terminal

(Rf23) No. 2 — (i97) No. 12:

Is the resistance less than 10  $\Omega$ ?

Yes

[Go to 6.](#)

No

Repair or replace the defective part.

## 6. CHECK COMMUNICATION STATUS BETWEEN WARNING BOX AND COMBINATION METER.

1. Remove the warning box, and install a properly operating warning box (new warning box).
2. Connect the connector and then turn the ignition switch to ON.

Is the warning box properly displayed?

Yes

Replace the warning box. [Ref. to INSTRUMENTATION/DRIVER INFO>Warning Box.](#)

No

[Go to 7.](#)

## 7. CHECK REAR SEAT SEATING SENSOR.

1. Turn the ignition switch to OFF.
2. Perform unit inspection for the rear seat seating sensor. [Ref. to SEAT BELT SYSTEM>Rear Seat Belt>INSPECTION > CHECK SEATING SENSOR MAT.](#)

Does the rear seat seating sensor operate normally?

Yes

[Go to 8.](#)

No

Replace the rear seat seating sensor mat together with the seat cushion pad. [Ref. to SEATS>Rear Seat.](#)

## 8. CHECK REAR SEAT BELT BUCKLE SWITCH.

Perform unit inspection for rear seat belt buckle switches.

Is the resistance when the belt is fastened 1 M $\Omega$  or more, and less than 10  $\Omega$  when the belt is detached?

Yes

[Go to 9.](#)

No

Replace the defective seat belt buckle switch. [Ref. to SEAT BELT SYSTEM>Rear Seat Belt.](#)

## 9. CHECK HARNESS.

1. Disconnect the combination meter connector and the rear seat belt buckle switch connector.
2. Check for short circuit to battery, open circuit and short circuit to ground between the combination meter connector and the rear seat belt buckle switch connector.

### Connector & terminal

#### RH

(i97) No. 8 — (R69) No. 1:

#### CTR

(i97) No. 9 — (L69) No. 1:

#### LH

(i97) No. 10 — (L69) No. 2:

Is harness normal?

Yes

Replace the combination meter assembly. [Ref. to INSTRUMENTATION/DRIVER INFO>Combination Meter.](#)

No

Repair or replace the defective part.

## SEAT BELT SYSTEM > Seat Belt Warning System

### NOTE

For procedure of components in the seat belt warning system, refer to the sections below.

- Combination meter assembly: [Ref. to INSTRUMENTATION/DRIVER INFO>Combination Meter.](#)
- Warning box: [Ref. to INSTRUMENTATION/DRIVER INFO>Warning Box.](#)
- Belt assembly front: [Ref. to SEAT BELT SYSTEM>Front Seat Belt.](#)
- Belt assembly rear: [Ref. to SEAT BELT SYSTEM>Rear Seat Belt.](#)
- Front seat: [Ref. to SEATS>Front Seat.](#)
- Rear seat cushion: [Ref. to SEATS>Rear Seat.](#)

## SEAT BELT SYSTEM > Front Seat Belt

### REMOVAL

---

#### 1. BELT ASSEMBLY FRONT OUT

**Caution:**

- **Before handling the airbag system components, refer to "CAUTION" of "General Description" in "AIRBAG SYSTEM". [Ref. to AIRBAG SYSTEM>General Description>CAUTION.](#)**
- **Side impact sensor (under the rear center seat) for the airbag system is located under the front center of the rear seat cushion. Be careful not to apply strong impact to the sensor when working with the rear seat cushion removed.**
- **Do not drop or subject the pretensioner to any impact.**
- **Since the pretensioner and bracket are integrated as a unit, do not disassemble them.**

1. Tilt the front seat backrest assembly forward, and move the front seat all the way forward.
2. Disconnect the ground terminal from the battery sensor, and wait for at least 60 seconds before starting work. [Ref. to REPAIR CONTENTS>NOTE > BATTERY.](#)
3. Remove the rear seat cushion assembly. [Ref. to SEATS>Rear Seat>REMOVAL.](#)
4. Remove the cover side sill front Rr and the trim panel assembly B pillar LWR. [Ref. to EXTERIOR/INTERIOR TRIM>Lower Inner Trim>REMOVAL.](#)
5. Remove the cover shoulder anchor. [Ref. to EXTERIOR/INTERIOR TRIM>Upper Inner Trim>REMOVAL > B PILLAR TRIM.](#)
6. Remove the belt assembly front OUT.
  - (1) Turn over the floor mat to disconnect the following connectors.
    - Front seat belt pretensioner & adaptive force limiter [Ref. to AIRBAG SYSTEM>Airbag Connector>PROCEDURE > PASSENGER'S AIRBAG MODULE, REAR SEAT BELT PRETENSIONER, FRONT SEAT BELT PRETENSIONER & ADAPTIVE FORCE LIMITER.](#)
    - Lap pretensioner (passenger's side) [Ref. to AIRBAG SYSTEM>Airbag Connector>PROCEDURE > KNEE AIRBAG MODULE, DRIVER'S AIRBAG MODULE & LAP SEAT BELT PRETENSIONER.](#)
  - (2) Remove the anchor bolts of seat belts.
  - (3) Remove the bolt to remove the seat belt retractor.
  - (4) Remove the lower anchor bolt (lap pretensioner), and remove the belt assembly front OUT.

7. Remove the trim panel assembly B pillar UPR. [Ref. to EXTERIOR/INTERIOR TRIM>Upper Inner Trim>REMOVAL > B PILLAR TRIM.](#)
8. Remove the bolt, and then remove the adjuster shoulder anchor.

## 2. BELT ASSEMBLY FRONT INN

**Caution:**

**Before handling the airbag system components, refer to "CAUTION" of "General Description" in "AIRBAG SYSTEM". [Ref. to AIRBAG SYSTEM>General Description>CAUTION.](#)**

1. Disconnect the ground terminal from the battery sensor, and wait for at least 60 seconds before starting work. [Ref. to REPAIR CONTENTS>NOTE > BATTERY.](#)
2. Remove the front seats. [Ref. to SEATS>Front Seat>REMOVAL.](#)
3. Remove the belt assembly front INN.
  - (1) Remove the clip for the seat belt harness located under the seat cushion.
  - (2) Remove the nut, and then remove the belt assembly front INN.

**Note:**

**For details on harness routing behind the seat, refer to "SEATS" section. [Ref. to SEATS>Front Seat>ASSEMBLY > CONNECTOR & HARNESS.](#)**

- Driver's seat

- Passenger's seat

## SEAT BELT SYSTEM > Front Seat Belt

### INSTALLATION

---

#### 1. BELT ASSEMBLY FRONT OUT

**Caution:**

- **Before handling the airbag system components, refer to "CAUTION" of "General Description" in "AIRBAG SYSTEM". [Ref. to AIRBAG SYSTEM>General Description>CAUTION.](#)**
- **Side impact sensor (under the rear center seat) for the airbag system is located under the front center of the rear seat cushion. Be careful not to apply strong impact to the sensor when working with the rear seat cushion removed.**

- 1.** Before installation, perform a unit inspection of retractor. [Ref. to SEAT BELT SYSTEM>Front Seat Belt>INSPECTION.](#)
- 2.** Install the adjuster shoulder anchor.  
**Tightening torque:**  
53 N·m (5.4 kgf-m, 39.1 ft-lb)
- 3.** Install the trim panel assembly B pillar UPR. [Ref. to EXTERIOR/INTERIOR TRIM>Upper Inner Trim>INSTALLATION > B PILLAR TRIM.](#)
- 4.** Install the belt assembly front OUT.

**Caution:**

- The parts of the driver and passenger sides are not the same. Before installation, make sure that the correct part is used.
- During installation, make sure that the seat belts are not twisted.
- After installation, make sure that the seat belt can be pulled out and retracted smoothly.

**Tightening torque:**

Refer to "COMPONENT" of "General Description" for the tightening torque. [Ref. to SEAT BELT SYSTEM>General Description>COMPONENT > FRONT SEAT BELT.](#)

5. Connect the connector of the pretensioner.
  - Front seat belt pretensioner & adaptive force limiter [Ref. to AIRBAG SYSTEM>Airbag Connector>PROCEDURE > PASSENGER'S AIRBAG MODULE, REAR SEAT BELT PRETENSIONER, FRONT SEAT BELT PRETENSIONER & ADAPTIVE FORCE LIMITER.](#)
  - Lap pretensioner (passenger's side) [Ref. to AIRBAG SYSTEM>Airbag Connector>PROCEDURE > KNEE AIRBAG MODULE, DRIVER'S AIRBAG MODULE & LAP SEAT BELT PRETENSIONER.](#)
6. Install the cover shoulder anchor. [Ref. to EXTERIOR/INTERIOR TRIM>Upper Inner Trim>INSTALLATION > B PILLAR TRIM.](#)
7. Install the trim panel assembly B pillar LWR and cover side sill front Rr. [Ref. to EXTERIOR/INTERIOR TRIM>Lower Inner Trim>INSTALLATION.](#)
8. Install the rear seat cushion assembly. [Ref. to SEATS>Rear Seat>INSTALLATION.](#)
9. Connect the ground terminal to battery sensor. [Ref. to REPAIR CONTENTS>NOTE > BATTERY.](#)
10. After installation, check the following points.
  - The seat belt is not twisted.
  - The seat belt can be pulled out and retracted smoothly.
  - The adjuster shoulder anchor can be moved smoothly.
  - Check that the airbag warning light lights up for approximately 6 seconds and then turns off when connecting the ground terminal to the battery sensor and turning the ignition switch to ON.

**2. BELT ASSEMBLY FRONT INN****Caution:**

**Before handling the airbag system components, refer to "CAUTION" of "General Description" in "AIRBAG SYSTEM".** [Ref. to AIRBAG SYSTEM>General Description>CAUTION.](#)

1. Install the belt assembly front INN.

**Caution:**

- Before installation, make sure that the correct part is used.
  - Make sure that the seat belt harness is not caught anywhere. Wrong harness routing may cause the harness short from pinch.
  - Do not forget the spring wave washer, when installing the belt assembly front INN.
  - Attach unwoven cloth of the spring wave washer with the cloth facing downward.
  - Apply grease to the bolt stepped section (a) and the stopper section (b) when replacing the belt assembly front INN.
- Do not apply grease to the thread and the nut tightening surface (c).  
Use grease not containing silicone. Vaporized silicone may adhere to the electrical contact and lead to poor continuity.

**Preparation items:**

Grease: IDEMITSU APOLLOIL AUTOLEX A or equivalent [Ref. to RECOMMENDED MATERIALS>GREASE>SEAT.](#)

(1) Install in the order of spring wave washer, belt assembly front INN and nut.

**Tightening torque:**

38 N·m (3.9 kgf-m, 28.0 ft-lb)

(2) Locate the seat belt harness and retain it with a harness clip.

**Note:**

**For details on harness routing behind the seat, refer to "SEATS" section. [Ref. to SEATS>Front Seat>ASSEMBLY > CONNECTOR & HARNESS.](#)**

2. Install the front seat. [Ref. to SEATS>Front Seat>INSTALLATION.](#)
3. Connect the ground terminal to battery sensor. [Ref. to REPAIR CONTENTS>NOTE > BATTERY.](#)
4. If the passenger's seat is removed, perform [Rezeroing] in the occupant detection system. [Ref. to AIRBAG\(DIAGNOSTICS\)>Rezero.](#)
5. If the passenger's seat is removed, perform "Occupant Detection System Inspection" to check if the occupant detection system operates normally. [Ref. to SEAT BELT SYSTEM>Seat Belt Warning System>INSPECTION.](#)

**SEAT BELT SYSTEM > Front Seat Belt****INSPECTION****1. VISUAL INSPECTION**

Check for the following, and replace with new parts if necessary.

- Pretensioner is cracked or deformed.
- Adjuster shoulder anchor is cracked or deformed.

- Seat belt is slackened, bent or worn.
- Seat belt is abnormally wound or extended.
- Belt assembly front INN is deformed or damaged.
- Seat belt buckle cannot be engaged properly.

## **2. ELR LOCK MECHANISM INSPECTION**

- 1.** Hold the retractor upright (as installed in the vehicle) and check the ELR lock mechanism.
- 2.** Tilt the retractor from the upright posture and check the following points.
  - It does not lock if the inclination angle is  $15^{\circ}$  or less.

- It remains locked if the inclination angle is  $27^{\circ}$  or more.

3. If the ELR lock mechanism does not operate properly, replace the belt assembly front OUT with a new part.

### 3. CHECK SEAT BELT SWITCH

- Driver's seat  
Check the resistance between the terminals when the belt assembly front INN is in each of the following operation conditions.

<b>Terminal No.</b>	<b>Inspection conditions</b>	<b>Standard</b>
2 – 1	Tongue plate inserted	1 M $\Omega$ or more
2 – 1	Tongue plate detached	1 $\Omega$ or less

Replace the belt assembly front INN if the inspection result is not within the standard.

- Passenger's seat  
Measure the current value between the terminals when the belt assembly front INN is in each of the following operation conditions.

<b>Terminal No.</b>	<b>Inspection conditions</b>	<b>Standard</b>
1 – 2	Tongue plate inserted	12 – 18 mA
1 – 2	Tongue plate detached	4 – 7 mA

Replace the belt assembly front INN if the inspection result is not within the standard.

#### **4. CHECK SEAT BELT WARNING LIGHT**

- 1.** Check the seat belt warning light.
  - Driver's seat: [Ref. to SEAT BELT SYSTEM>Seat Belt Warning System>INSPECTION > CHECK DRIVER'S SEAT BELT WARNING LIGHT.](#)
  - Passenger's seat: [Ref. to SEAT BELT SYSTEM>Seat Belt Warning System>INSPECTION > CHECK PASSENGER'S SEAT BELT WARNING LIGHT.](#)
- 2.** If the inspection result indicates an improper operation, check the seat belt switch and seat belt warning system.
  - Seat belt switch: [Ref. to SEAT BELT SYSTEM>Front Seat Belt>INSPECTION > CHECK SEAT BELT SWITCH.](#)
  - Driver's seat belt warning system: [Ref. to SEAT BELT SYSTEM>Seat Belt Warning System>INSPECTION > DRIVER'S SEAT BELT WARNING LIGHT DOES NOT ILLUMINATE.](#)
  - Passenger's seat belt warning system: [Ref. to SEAT BELT SYSTEM>Seat Belt Warning System>INSPECTION > PASSENGER'S SEAT BELT WARNING LIGHT DOES NOT ILLUMINATE.](#)

## SEAT BELT SYSTEM > Rear Seat Belt

### REMOVAL

---

#### 1. BELT ASSEMBLY REAR OUT RH AND LH

**Caution:**

- **Before handling the airbag system components, refer to "CAUTION" of "General Description" in "AIRBAG SYSTEM". [Ref. to AIRBAG SYSTEM>General Description>CAUTION.](#)**
- **Side impact sensor (under the rear center seat) for the airbag system is located under the front center of the rear seat cushion. Be careful not to apply strong impact to the sensor when working with the rear seat cushion removed.**

- 1.** Disconnect the ground terminal from the battery sensor, and wait for at least 60 seconds before starting work. [Ref. to REPAIR CONTENTS>NOTE > BATTERY.](#)
- 2.** Remove the rear seat cushion assembly and the backrest assembly. [Ref. to SEATS>Rear Seat>REMOVAL.](#)
- 3.** Remove the trim panel assembly C pillar LWR and the trim panel assembly C pillar. [Ref. to EXTERIOR/INTERIOR TRIM>Rear Quarter Trim>REMOVAL.](#)
- 4.** Remove the trim panel assembly rear shelf. [Ref. to EXTERIOR/INTERIOR TRIM>Rear Shelf Trim>REMOVAL.](#)
- 5.** Remove the belt assembly rear OUT.
  - (1) Disconnect connector of the pretensioner. [Ref. to AIRBAG SYSTEM>Airbag Connector>PROCEDURE > PASSENGER'S AIRBAG MODULE, REAR SEAT BELT PRETENSIONER, FRONT SEAT BELT PRETENSIONER & ADAPTIVE FORCE LIMITER.](#)
  - (2) Remove the bolt, and then remove the belt assembly rear OUT.

#### 2. BELT ASSEMBLY REAR OUT CTR

**Caution:**

- **Before handling the airbag system components, refer to "CAUTION" of "General Description" in "AIRBAG SYSTEM". [Ref. to AIRBAG SYSTEM>General Description>CAUTION.](#)**
- **Side impact sensor (under the rear center seat) for the airbag system is located under the front center of the rear seat cushion. Be careful not to apply strong impact to the sensor when working with the rear seat cushion removed.**

- 1.** Disconnect the ground terminal from the battery sensor, and wait for at least 60 seconds before starting work. [Ref. to REPAIR CONTENTS>NOTE > BATTERY.](#)
- 2.** Remove the rear seat cushion assembly and the backrest assembly. [Ref. to SEATS>Rear Seat>REMOVAL.](#)
- 3.** Remove the trim panel assembly C pillar LWR and the trim panel assembly C pillar. [Ref. to EXTERIOR/INTERIOR TRIM>Rear Quarter Trim>REMOVAL.](#)
- 4.** Remove the belt assembly rear OUT CTR lower anchor.
  - (1) Disconnect the connector.
  - (2) Remove the bolts, and then remove the belt assembly rear OUT CTR lower anchor.
- 5.** Remove the trim panel assembly rear shelf. [Ref. to EXTERIOR/INTERIOR TRIM>Rear Shelf Trim>REMOVAL.](#)
- 6.** Remove the bolts, and then remove the belt assembly rear OUT CTR.

### **3. BELT ASSEMBLY REAR INN CENTER LH**

**Caution:**

- Before handling the airbag system components, refer to "CAUTION" of "General Description" in "AIRBAG SYSTEM". [Ref. to AIRBAG SYSTEM>General Description>CAUTION.](#)
- Side impact sensor (under the rear center seat) for the airbag system is located under the front center of the rear seat cushion. Be careful not to apply strong impact to the sensor when working with the rear seat cushion removed.

1. Disconnect the ground terminal from the battery sensor, and wait for at least 60 seconds before starting work. [Ref. to REPAIR CONTENTS>NOTE > BATTERY.](#)
2. Remove the rear seat cushion assembly. [Ref. to SEATS>Rear Seat>REMOVAL.](#)
3. Remove the belt assembly rear INN center RH and LH.
  - (1) Disconnect the connector.
  - (2) Remove the bolts and then remove the belt assembly rear INN center RH and LH.

**SEAT BELT SYSTEM > Rear Seat Belt****INSTALLATION**

---

**1. BELT ASSEMBLY REAR OUT RH AND LH****Caution:**

- Before handling the airbag system components, refer to "CAUTION" of "General Description" in "AIRBAG SYSTEM". [Ref. to AIRBAG SYSTEM>General Description>CAUTION.](#)
- Side impact sensor (under the rear center seat) for the airbag system is located under the front center of the rear seat cushion. Be careful not to apply strong impact to the sensor when working with the rear seat cushion removed.

1. Before installation, perform a unit inspection of retractor. [Ref. to SEAT BELT SYSTEM>Rear Seat Belt>INSPECTION.](#)
2. Install the belt assembly rear OUT.

**Caution:**

- **During installation, make sure that the seat belts are not twisted.**
- **After installation, make sure that the seat belts are smoothly extended and wound.**
- **While tightening, push the anchor plate against the stud bolt.**

A RH side

B LH side

(a) Front side of vehicle

(b) Stud bolt

**Tightening torque:**

30 N·m (3.1 kgf-m, 22.1 ft-lb)

3. Connect the connector of the pretensioner. [Ref. to AIRBAG SYSTEM>Airbag Connector>PROCEDURE > PASSENGER'S AIRBAG MODULE, REAR SEAT BELT PRETENSIONER, FRONT SEAT BELT PRETENSIONER & ADAPTIVE FORCE LIMITER.](#)
4. Install the trim panel assembly rear shelf. [Ref. to EXTERIOR/INTERIOR TRIM>Rear Shelf Trim>INSTALLATION.](#)
5. Install the trim panel assembly C pillar and the trim panel assembly C pillar LWR. [Ref. to EXTERIOR/INTERIOR TRIM>Rear Quarter Trim>INSTALLATION.](#)
6. Install the backrest assembly and rear seat cushion assembly. [Ref. to SEATS>Rear Seat>INSTALLATION.](#)
7. Connect the ground terminal to battery sensor. [Ref. to REPAIR CONTENTS>NOTE > BATTERY.](#)
8. After installation, check the following points.
  - The seat belt is not twisted.
  - The seat belt can be pulled out and retracted smoothly.

**2. BELT ASSEMBLY REAR OUT CTR****Caution:**

- **Before handling the airbag system components, refer to "CAUTION" of "General Description" in "AIRBAG SYSTEM".** [Ref. to AIRBAG SYSTEM>General Description>CAUTION.](#)
- **Side impact sensor (under the rear center seat) for the airbag system is located under the front center of the rear seat cushion. Be careful not to apply strong impact to the sensor when working with the rear seat cushion removed.**

1. Install the belt assembly rear OUT CTR.

**Tightening torque:**

Refer to "COMPONENT" of "General Description" for the tightening torque. [Ref. to SEAT BELT SYSTEM>General Description>COMPONENT > REAR SEAT BELT.](#)

2. Install the trim panel assembly rear shelf. [Ref. to EXTERIOR/INTERIOR TRIM>Rear Shelf Trim>INSTALLATION.](#)
3. Install the belt assembly rear OUT CTR lower anchor, and connect the connector.  
**Tightening torque:**  
30 N·m (3.1 kgf-m, 22.1 ft-lb)
4. Install the trim panel assembly C pillar and the trim panel assembly C pillar LWR. [Ref. to EXTERIOR/INTERIOR TRIM>Rear Quarter Trim>INSTALLATION.](#)
5. Install the backrest assembly and rear seat cushion assembly. [Ref. to SEATS>Rear Seat>INSTALLATION.](#)
6. Connect the ground terminal to battery sensor. [Ref. to REPAIR CONTENTS>NOTE > BATTERY.](#)
7. After installation, check the following points.
  - The seat belt is not twisted.
  - The seat belt can be pulled out and retracted smoothly.

**Note:**

**While performing the winding inspection, place your hand on the tongue plate.**

### 3. BELT ASSEMBLY REAR INN CENTER LH

**Caution:**

- **Before handling the airbag system components, refer to "CAUTION" of "General Description" in "AIRBAG SYSTEM". [Ref. to AIRBAG SYSTEM>General Description>CAUTION.](#)**
- **Side impact sensor (under the rear center seat) for the airbag system is located under the front center of the rear seat cushion. Be careful not to apply strong impact to the sensor when working with the rear seat cushion removed.**

1. Install the belt assembly rear INN center RH and LH, and connect the connector.  
**Tightening torque:**  
30 N·m (3.1 kgf-m, 22.1 ft-lb)
2. Install the rear seat cushion assembly. [Ref. to SEATS>Rear Seat>INSTALLATION.](#)
3. Connect the ground terminal to battery sensor. [Ref. to REPAIR CONTENTS>NOTE > BATTERY.](#)
4. After installation, check the following points.
  - The seat belt is not twisted.
  - The seat belt engagement can be performed smoothly.

## SEAT BELT SYSTEM > Rear Seat Belt

### INSPECTION

---

#### 1. VISUAL INSPECTION

Check for the following, and replace with new parts if necessary.

- Seat belt is slackened, bent or worn.
- Seat belt is abnormally wound or extended.
- Belt assembly rear INN is deformed or damaged.
- Seat belt buckle cannot be engaged properly.

## 2. ELR LOCK MECHANISM INSPECTION

1. Hold the retractor upright (as installed in the vehicle) and check the ELR lock mechanism.
2. Tilt the retractor from the upright posture and check the following points.
  - It does not lock if the inclination angle is 15° or less.

- It remains locked if the inclination angle is 27° or more.

3. If the ELR lock mechanism does not operate properly, replace the belt assembly rear OUT with a new part.

## 3. CHECK SEAT BELT SWITCH

1. Measure the resistance between the terminals using each belt assembly rear INN inspection conditions.
  - RH

Terminal No.	Inspection conditions	Standard
A 1 — B 1	Always	1 Ω or less
A 2 — B 2	Tongue plate inserted	1 MΩ or more

<b>Terminal No.</b>	<b>Inspection conditions</b>	<b>Standard</b>
A 2 — B 2	Tongue plate detached	1 Ω or less

- CTR and LH

<b>Terminal No.</b>	<b>Inspection conditions</b>	<b>Standard</b>
A 1 — B 1	Always	1 Ω or less
A 3 — B 3	CTR tongue plate inserted	1 MΩ or more
A 3 — B 3	CTR tongue plate detached	1 Ω or less
A 2 — B 2	Always	1 Ω or less
A 4 — B 4	LH tongue plate inserted	1 MΩ or more
A 4 — B 4	LH tongue plate detached	1 Ω or less

2. Replace the belt assembly rear INN if the inspection result is not within the standard value.

#### **4. CHECK SEATING SENSOR MAT**

1. Disconnect the connector of the seat belt switch and seating sensor mat.
2. Measure the resistance between the terminals when the seating sensor mat is in each of the following operation conditions.
  - RH

<b>Terminal No.</b>	<b>Inspection conditions</b>	<b>Standard</b>
1 — 2	Sit on the rear seat RH	1 Ω or less
1 — 2	Do not sit on the rear seat RH	1 MΩ or more

- CTR

Terminal No.	Inspection conditions	Standard
1 – 3	Sit on the rear seat CTR	1 $\Omega$ or less
1 – 3	Do not sit on the rear seat CTR	1 M $\Omega$ or more

- LH

Terminal No.	Inspection conditions	Standard
2 – 4	Sit on the rear seat LH	1 $\Omega$ or less
2 – 4	Do not sit on the rear seat LH	1 M $\Omega$ or more

3. Replace the rear seat seating sensor mat together with the pad & frame assembly rear cushion if the inspection result is not within the standard value.

## 5. CHECK SEAT BELT WARNING LIGHT

1. Check the rear seat belt warning light. [Ref. to SEAT BELT SYSTEM>Seat Belt Warning System>INSPECTION > CHECK REAR SEAT BELT WARNING LIGHT.](#)
2. If the inspection result indicates an improper operation, check the rear seat belt switch and rear seat belt warning system.
  - Rear seat belt switch: [Ref. to SEAT BELT SYSTEM>Rear Seat Belt>INSPECTION > CHECK SEAT BELT SWITCH.](#)
  - Rear seat belt warning system: [Ref. to SEAT BELT SYSTEM>Seat Belt Warning System>INSPECTION > REAR SEAT BELT WARNING LIGHT DOES NOT ILLUMINATE.](#)

## SEAT BELT SYSTEM > Disposal of Pretensioner

### PROCEDURE

#### Caution:

- Before handling the airbag system components, refer to "CAUTION" of "General Description" in "AIRBAG SYSTEM". [Ref. to AIRBAG SYSTEM>General Description>CAUTION.](#)
- Side impact sensor (under the rear center seat) for the airbag system is located under the front center of the rear seat cushion. Be careful not to apply strong impact to the sensor when working with the rear seat cushion removed.
- Before discarding a pretensioner, always perform an activation process to prevent any false activation.
- Wear protective gloves, safety goggles and earplugs during this operation. Wash your hands afterwards.
- Do not touch the pretensioner just after activation because it is very hot. Before handling it for disposal, wait for 40 minutes.
- Perform a pretensioner operation process in a safe, level place. Do not perform the process outdoors when there is a strong rain or wind.
- Perform front seat belt operation process at each location one after another. Do not perform operation process simultaneously on front pretensioner, lap pretensioner and adaptive force limiter.
- Do not drop or damage the pretensioner.
- A large explosive noise will occur when the pretensioner is deployed. Warn persons in the area, and do not allow anyone to approach a radius of 5 m (16 ft) from the discard location.
- After activating the pretensioner, smoke may arise. Therefore, always perform an operation process in a well-ventilated place without any smoke sensor.
- Do not expose the activated pretensioner to water.
- Wrap the activated pretensioner in a sealed vinyl bag when discarding.
- If it is impossible to perform a pretensioner activation process due to some situational reasons, consult SUBARU dealership or one of the authorized workshops.

1. Fold the backrest all the way forward, and move the front seat all the way forward.
2. Turn the ignition switch to OFF.
3. Disconnect the ground terminal from the battery sensor, and wait for at least 60 seconds before starting work. [Ref. to REPAIR CONTENTS>NOTE > BATTERY.](#)
4. Disconnect connector of the pretensioner.
  - Front

- Rear

**5.** Activate each pretensioner.

**Preparation tool:**

ST1: AIRBAG DEPLOYMENT TOOL (98299PA030)

ST2: TEST HARNESS ADAPTER D (98299SA010)

Front pretensioner

Adaptive force limiter

ST3: TEST HARNESS ADAPTER F (98299SA050)

Lap pretensioner

ST4: TEST HARNESS ADAPTER AM (98299FJ000)

Rear pretensioner

(1) Short the ST1 alligator clip to the terminal.

**Caution:**

**Short ST1 terminals until just before the pretensioner operation process.**

(2) Connect ST1 (A) and ST2, ST3 or ST4 (B).

(3) Connect the connector of ST2, ST3, or ST4 to the pretensioner or adaptive force limiter.

(4) Make sure there is no one inside the vehicle.

(5) Extend the wiring of ST1 to the limit, and close all the windows and sunroof completely.

- (6) Move the battery 5 m (16 ft) or more from the vehicle, and affix nearby.
- (7) Connect the ST1 alligator clip to the battery negative (–) terminal.
- (8) Connect the other cable of ST1 to the battery positive (+) terminal, and activate the pretensioner.

**Caution:**

- **After activation, the pretensioner will be extremely hot. Let it cool down for at least 40 minutes in an area with no one around.**
- **Do not expose the activated pretensioner to water.**

- 6.** Remove the seat belt outer.
    - Front: [Ref. to SEAT BELT SYSTEM>Front Seat Belt>REMOVAL > BELT ASSEMBLY FRONT OUT.](#)
    - Rear: [Ref. to SEAT BELT SYSTEM>Rear Seat Belt>REMOVAL.](#)
  - 7.** Cut the seat belt at a position as close as possible to the seat belt retractor.
- 
- 8.** Cut the seat belt at a position as close as possible to the lap seat belt pretensioner.

9. Place the activated pretensioner in a sealed vinyl bag, then discard.