



-
1. General Description
 2. Differential Gear Oil
 3. Front Differential
 4. Rear Differential (VB-type)
 5. Differential Front Oil Seal
 6. Differential Side Retainer Oil Seal
 7. Rear Differential Front Member
 8. Rear Differential Mount Bushing
 9. Symptoms and causes

DIFFERENTIALS > General Description

CAUTION

- When performing service operation, refer to "Repair Contents" in "General Description".  [Ref. to REPAIR CONTENTS>Repair Contents.](#)
- Prior to starting work, pay special attention to the following:
 1. Always wear work clothes, a work cap, and protective shoes. Additionally, wear a helmet, protective goggles, etc. if necessary.
 2. Protect the vehicle using a seat cover, fender cover, etc.
 3. Prepare the service tools, clean cloth, containers to catch grease and oil, etc.
- Prevent scattering of grease and oil. If it scatters, wipe it off immediately to prevent it from penetrating the floor or flowing out, to protect the environmental.
- If the grease and oil is spilt over the engine, exhaust pipe or the under cover, completely wipe it off to avoid emission of smoke or causing a fire.
- Vehicle components are extremely hot immediately after driving. Be wary of receiving burns from heated parts.
- When performing a repair, identify the cause of trouble and avoid unnecessary work.
- Before disconnecting connectors of sensors or units, be sure to disconnect the ground terminal from the battery sensor.
- Always use the jack-up point when the lifting device, shop jacks or rigid racks are used to support the vehicle.
- Before starting works, remove dirt and corrosion around the target area.
- Keep the removed parts in order and protect them from dust and dirt.
- All removed parts, if to be reused, should be reinstalled in the original positions with attention to the correct directions, etc.
- For the parts except for the non-reusable parts, replace them with new parts if necessary.
- Be sure to tighten bolts and nuts to the specified torque.
- Always use new application oil during work.

SPECIFICATION**1. REAR DIFFERENTIAL**

Rear differential type		VB3
LSD type		—
Type of gear		Hypoid gear
Gear ratio	MT model	4.111
	CVT model	4.444
Drive pinion bearing preload		 Ref. to DIFFERENTIALS>Rear Differential (VB-type)>ASSEMBLY.
Backlash between the differential bevel gear and differential bevel pinion	mm (in)	0.13 — 0.18 (0.005 — 0.007)
Hypoid gear set backlash	mm (in)	0.10 — 0.15 (0.004 — 0.006)
Companion flange mating surface runout	mm (in)	0.08 (0.003)
Companion flange runout on its inner side	mm (in)	0.08 (0.003)

2. DIFFERENTIAL GEAR OIL**Caution:**

Do not mix different kinds of oil.

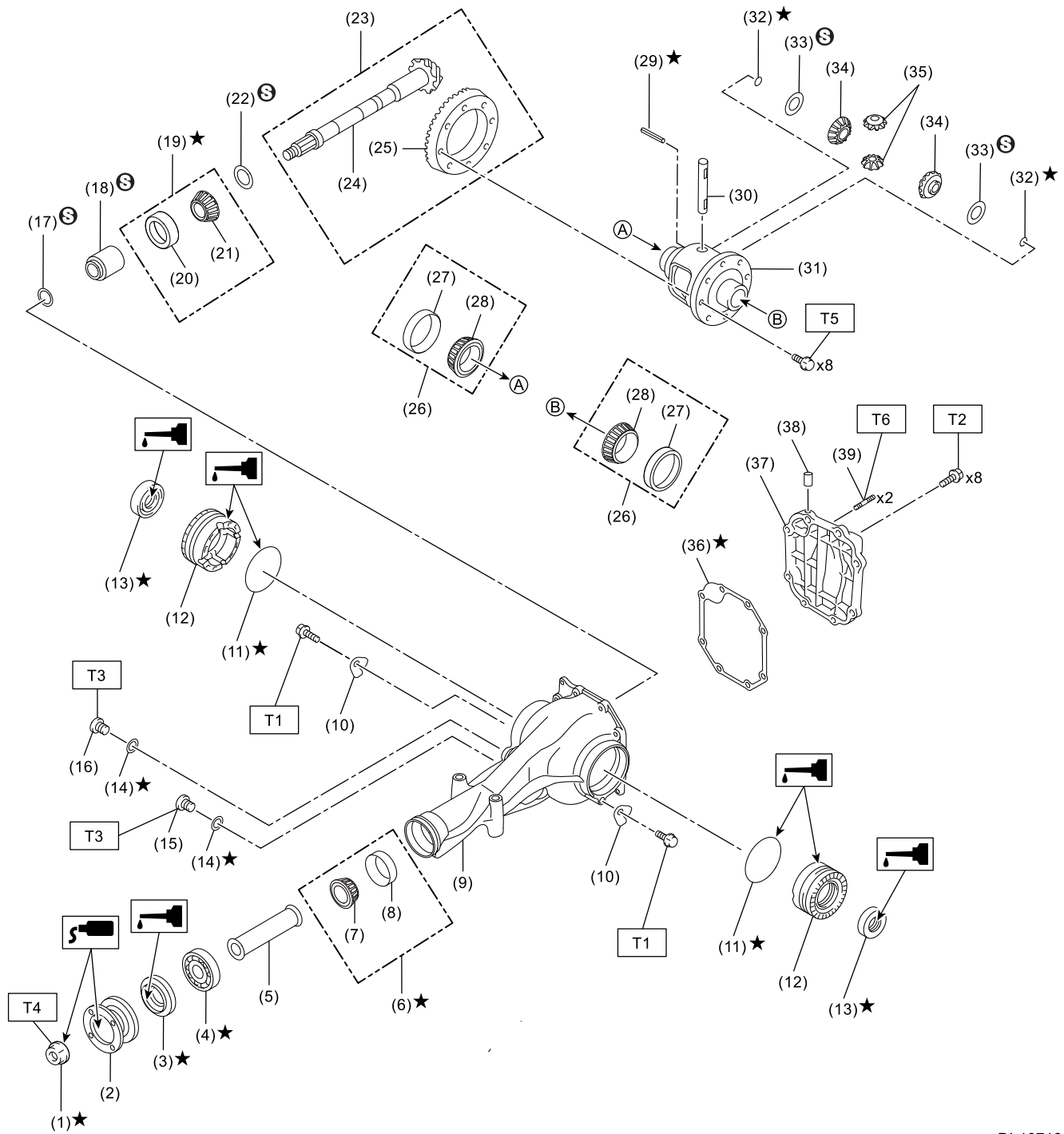
Note:

Using any materials other than recommended may result in abnormal noise, vibration, functional decline, or poor fuel economy.

Recommended and alternative materials	Capacity
<ul style="list-style-type: none"> Recommended materials: API standard GL-5 (75W-90) 	L (US qt, Imp qt) 0.8 (0.8, 0.7)

COMPONENT

1. REAR DIFFERENTIAL



DI-10716

- | | | |
|---------------------------------|-------------------------------------|--------------------------------|
| (1) ★ Self-locking nut | (17) Preload adjusting washer | (33) Thrust washer |
| (2) Companion flange | (18) Preload adjusting spacer | (34) Differential bevel gear |
| (3) Differential front oil seal | (19) Rear bearing | (35) Differential bevel pinion |
| (4) ★ Pilot bearing | (20) Rear bearing outer race | (36) Gasket |
| (5) Spacer | (21) Rear bearing inner race | (37) Rear cover |
| (6) ★ Front bearing | (22) Pinion height adjusting washer | (38) Air breather cap |

- | | |
|--|------------------------------|
| (7) Front bearing inner race | (23) Hypoid gear set |
| (8) Front bearing outer race | (24) Drive pinion |
| (9) Differential carrier | (25) Driven gear |
| (10) Lock plate | (26) Side bearing* |
| (11) O-ring | (27) Side bearing outer race |
| (12) Differential side retainer | (28) Side bearing inner race |
| (13) Differential side retainer oil seal | (29) Spring pin |
| (14) Gasket | (30) Pinion shaft |
| (15) Filler plug | (31) Differential case |
| (16) Drain plug | (32) Circlip |


- (39) Stud bolt


Tightening torque: N·m (kgf-m, ft-lb)


T1: 25 (2.5, 18.4)

T2: 34 (3.5, 25.1)

T3: 50 (5.1, 36.9)

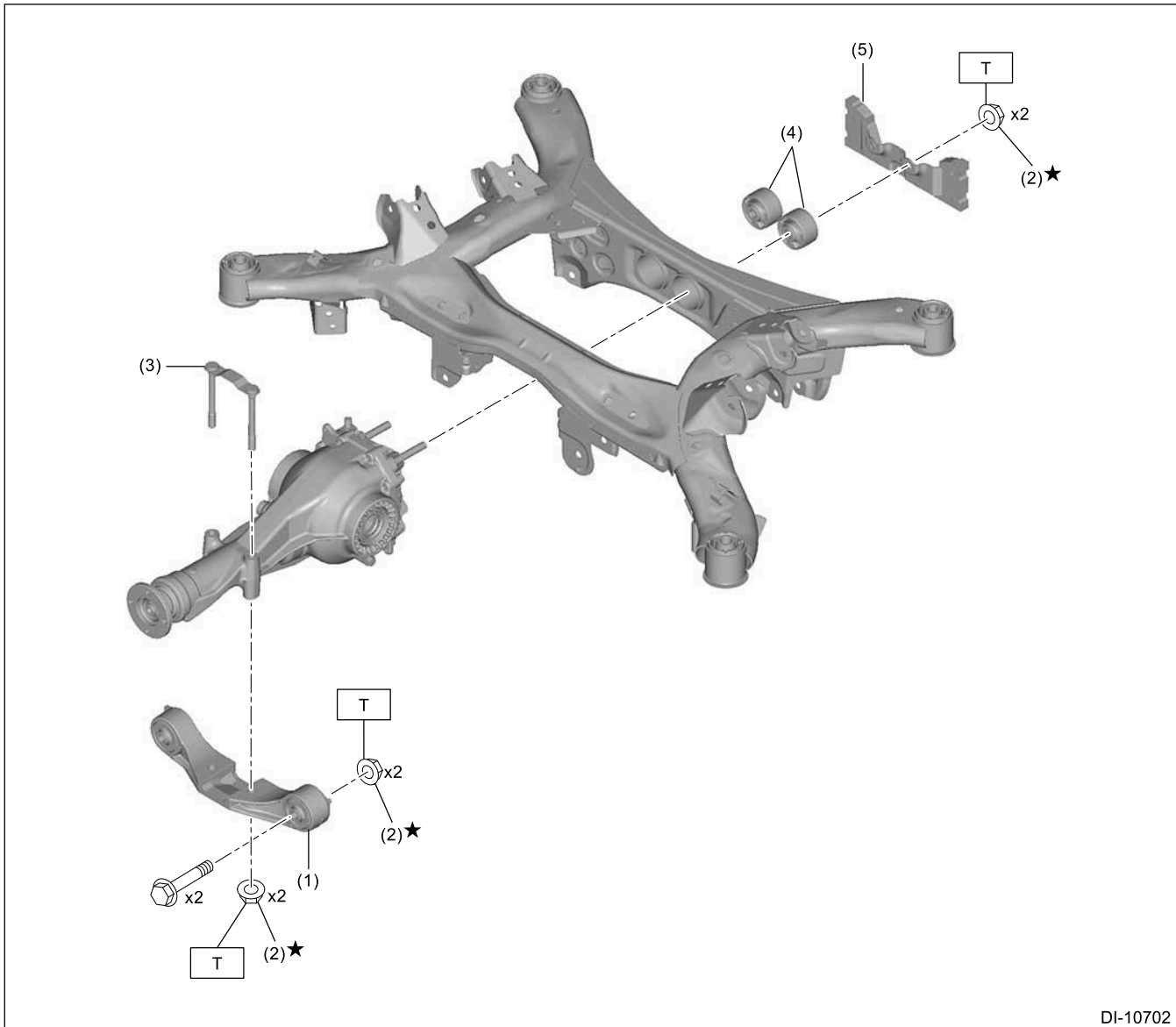
T4:  Ref. to [DIFFERENTIALS>Rear Differential \(VB-type\)>ASSEMBLY.](#)

T5:  Ref. to [DIFFERENTIALS>Rear Differential \(VB-type\)>ASSEMBLY.](#)

T6:  Ref. to [DIFFERENTIALS>Rear Differential \(VB-type\)>ASSEMBLY.](#)

*: If the side bearing outer race is removed from the differential side retainer, or if the side bearing inner race is removed from the differential case, replace the side bearing with a new part.


2. REAR DIFFERENTIAL MOUNTING SYSTEM



DI-10702

- | | |
|------------------------------------|-------------------------------------|
| (1) Rear differential front member | (4) Rear differential mount bushing |
| (2) Self-locking nut | (5) Mass damper (CVT model) |
| (3) Rear differential member plate | |

Tightening torque: N·m (kgf-m, ft-lb)

T:  **Ref. to**
DIFFERENTIALS>Rear
Differential (VB-
type)>INSTALLATION.

PREPARATION TOOL**1. SPECIAL TOOL**

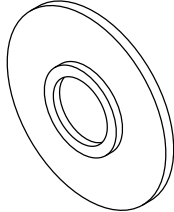
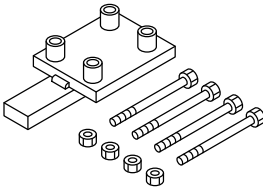
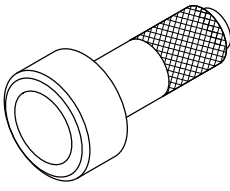
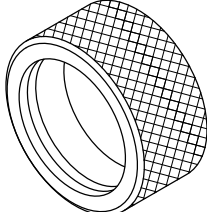
ILLUSTRATION	TOOL NUMBER	DESCRIPTION	REMARKS
 <p data-bbox="305 699 435 720">ST-39817700</p>	398177700	INSTALLER	Used for installing the rear bearing inner race.
 <p data-bbox="305 1066 435 1087">ST-398217700</p>	398217700	ATTACHMENT SET	Used for disassembly and assembly of differential carrier.
 <p data-bbox="305 1434 435 1455">ST-398417700</p>	398417700	DRIFT	Used for installing the side bearing outer race.
 <p data-bbox="305 1801 435 1822">ST-398437700</p>	398437700	OIL SEAL INSTALLER	Used for installing the differential side retainer oil seal.

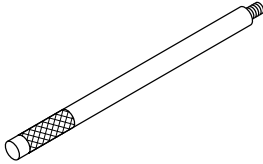
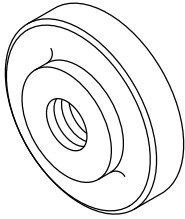
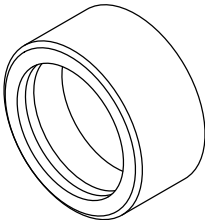
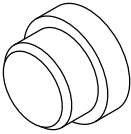
ILLUSTRATION	TOOL NUMBER	DESCRIPTION	REMARKS
 <p data-bbox="310 506 435 527">ST-398477701</p>	398477701	HANDLE	<p data-bbox="935 191 1393 258">Used for installing the rear bearing outer race.</p> <div data-bbox="935 264 1440 384" style="border: 1px solid black; padding: 5px;"> <p data-bbox="935 268 1016 296">Note:</p> <p data-bbox="959 306 1370 380">Used together with DRIFT 2 (398477703).</p> </div>
 <p data-bbox="310 873 435 894">ST-398477703</p>	398477703	DRIFT 2	<ul data-bbox="928 556 1440 825" style="list-style-type: none"> <li data-bbox="928 556 1440 623">• Used for installing the front bearing outer race. <div data-bbox="959 630 1440 749" style="border: 1px solid black; padding: 5px;"> <p data-bbox="959 634 1040 661">Note:</p> <p data-bbox="984 672 1386 745">Used together with INSTALLER (18654AA000).</p> </div> <ul data-bbox="928 751 1440 825" style="list-style-type: none"> <li data-bbox="928 751 1440 825">• Used for installing the rear bearing outer race. <div data-bbox="959 831 1440 951" style="border: 1px solid black; padding: 5px;"> <p data-bbox="959 835 1040 863">Note:</p> <p data-bbox="984 873 1398 947">Used together with HANDLE (398477701).</p> </div>
 <p data-bbox="310 1272 435 1293">ST-398487700</p>	398487700	DRIFT	<p data-bbox="935 959 1393 1026">Used for installing the side bearing inner race.</p>
 <p data-bbox="310 1642 435 1663">ST-398497701</p>	398497701	SEAT	<p data-bbox="935 1325 1393 1392">Used for removing the side bearing inner race.</p> <div data-bbox="935 1398 1440 1518" style="border: 1px solid black; padding: 5px;"> <p data-bbox="935 1402 1016 1430">Note:</p> <p data-bbox="959 1440 1425 1514">Used together with PULLER SET (899524100).</p> </div>

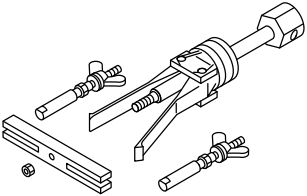
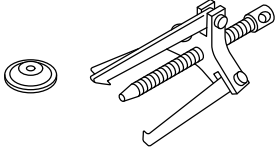
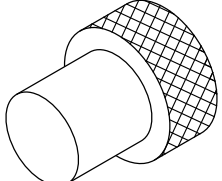
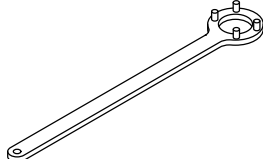
ILLUSTRATION	TOOL NUMBER	DESCRIPTION	REMARKS
 <p data-bbox="305 504 430 525">ST-398527700</p>	398527700	PULLER ASSY	<p data-bbox="933 189 1396 262">Used for removing the side bearing outer race.</p> <div data-bbox="933 262 1437 378" style="border: 1px solid black; padding: 5px;"> <p data-bbox="933 268 1015 298">Note:</p> <p data-bbox="958 304 1339 378">Used together with CLAW (18760AA000).</p> </div>
 <p data-bbox="305 871 430 892">ST-399703600</p>	399703600	PULLER ASSY	Used for removing companion flange.
 <p data-bbox="305 1239 430 1260">ST-399780104</p>	399780104	WEIGHT	Used for installing the drive pinion.
 <p data-bbox="305 1606 430 1627">ST-498427200</p>	498427200	FLANGE WRENCH	<ul data-bbox="933 1291 1437 1554" style="list-style-type: none"> • Used for removing and installing the self-locking nut of companion flange. • Used for adjusting hypoid gear set backlash. • Used for adjusting preload on the side bearing.

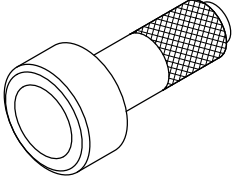
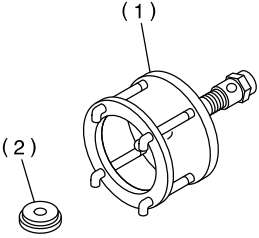
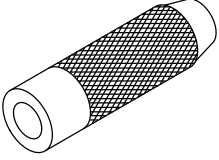
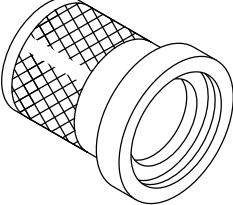
ILLUSTRATION	TOOL NUMBER	DESCRIPTION	REMARKS
 <p data-bbox="310 506 435 527">ST-498447120</p>	498447120	INSTALLER	Used for installing the differential front oil seal.
 <p data-bbox="310 873 435 894">ST-899524100</p>	899524100	PULLER SET	<p>Used for removing the side bearing inner race.</p> <ul style="list-style-type: none"> • (1) Puller • (2) Cap <div data-bbox="935 709 1438 827" style="border: 1px solid black; padding: 5px;"> <p>Note: Used together with SEAT (398497701).</p> </div>
 <p data-bbox="310 1241 435 1262">ST-899580100</p>	899580100	INSTALLER	<ul style="list-style-type: none"> • Used for installing the front bearing inner race. • Used for installing the pilot bearing.
 <p data-bbox="310 1608 435 1629">ST-899874100</p>	899874100	INSTALLER	Used for installing the companion flange.

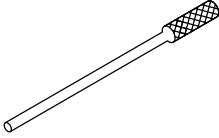
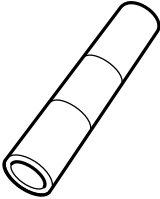
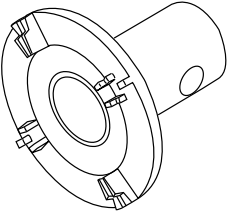
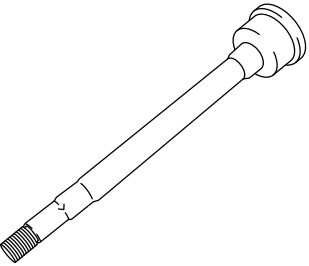
ILLUSTRATION	TOOL NUMBER	DESCRIPTION	REMARKS
 <p data-bbox="310 506 435 527">ST-899904100</p>	899904100	STRAIGHT PIN REMOVER	Used for removing and installing the spring pin.
 <p data-bbox="302 877 435 898">ST18654AA000</p>	18654AA000	INSTALLER	Used for installing the front bearing outer race. <div data-bbox="935 632 1440 747" style="border: 1px solid black; padding: 5px;"> <p>Note: Used together with DRIFT 2 (398477703).</p> </div>
 <p data-bbox="302 1224 435 1245">ST18658AA021</p>	18658AA021	WRENCH COMPL RETAINER	<ul style="list-style-type: none"> • Used for removing and installing the differential side retainer. • Used for adjusting hypoid gear set backlash.
 <p data-bbox="302 1608 435 1629">ST18678AA000</p>	18678AA000	DUMMY SHAFT	<ul style="list-style-type: none"> • Used for adjusting preload for front bearing and rear bearing. • Used for adjusting drive pinion height. <div data-bbox="959 1444 1440 1602" style="border: 1px solid black; padding: 5px;"> <p>Note: Used together with DIFFERENTIAL CARRIER GAUGE (18831AA010).</p> </div>

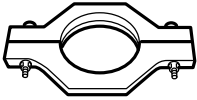
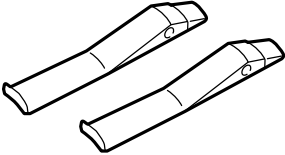
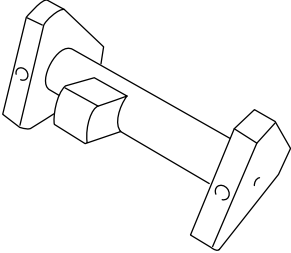
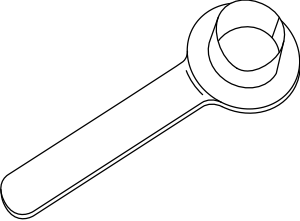
ILLUSTRATION	TOOL NUMBER	DESCRIPTION	REMARKS
 <p data-bbox="298 506 431 527">ST18720AA000</p>	18720AA000	REMOVER	Used for removing the rear bearing inner race.
 <p data-bbox="298 873 431 894">ST18760AA000</p>	18760AA000	CLAW	Used for removing the side bearing outer race. <div data-bbox="935 632 1438 747" style="border: 1px solid black; padding: 5px;"> <p>Note: Used together with PULLER ASSY (398527700).</p> </div>
 <p data-bbox="298 1245 431 1266">ST18831AA010</p>	18831AA010	DIFFERENTIAL CARRIER GAUGE	Used for adjusting drive pinion height. <div data-bbox="935 961 1438 1077" style="border: 1px solid black; padding: 5px;"> <p>Note: Used together with DUMMY SHAFT (18678AA000).</p> </div>
 <p data-bbox="298 1608 431 1629">ST28099PA090</p>	28099PA090	OIL SEAL PROTECTOR	Used for installing the rear drive shaft.

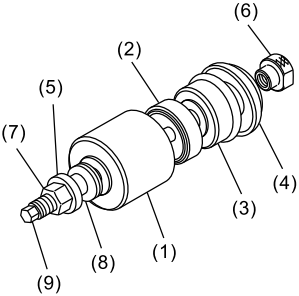
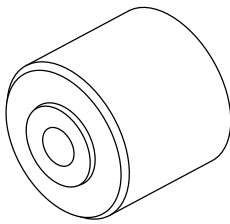
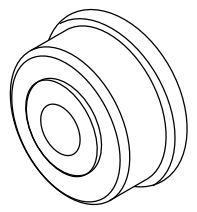
ILLUSTRATION	TOOL NUMBER	DESCRIPTION	REMARKS
 <p data-bbox="300 504 430 525">ST41399FG001</p>	41399FG001	SPECIAL TOOL ASSY	<ul style="list-style-type: none"> • Used for removing and installing the rear differential mount bushing. <div style="border: 1px solid black; padding: 5px; margin: 5px 0;"> <p>Caution: Apply the molybdenum grease on the threads.</p> </div> <ul style="list-style-type: none"> • Use (1), (2), (5), (6), (7), (8) and (9) for removal. • Use (3), (4), (5), (6), (7), (8) and (9) for installation. <p>(1) SPECIAL TOOL A (41399FG010) (2) SPECIAL TOOL C (41399FG031) (3) SPECIAL TOOL B (41399FG020) (4) SPECIAL TOOL D (41399FG041) (5) SPECIAL TOOL SLEEVE (41399FG050) (6) SPECIAL TOOL RING (41399FG061) (7) SPECIAL TOOL NUT (41399FG070) (8) SPECIAL TOOL BEARING (41399FG080) (9) SPECIAL TOOL SHAFT (41399FG091)</p>
 <p data-bbox="300 1407 430 1428">ST41399FG010</p>	41399FG010	SPECIAL TOOL A	<p>Used for removing the rear differential mount bushing.</p> <div style="border: 1px solid black; padding: 5px; margin: 5px 0;"> <p>Note: For combination of tools, refer to "SPECIAL TOOL ASSY (41399FG001)".</p> </div>
 <p data-bbox="300 1774 430 1795">ST41399FG020</p>	41399FG020	SPECIAL TOOL B	<p>Used for installing the rear differential mount bushing.</p> <div style="border: 1px solid black; padding: 5px; margin: 5px 0;"> <p>Note: For combination of tools, refer to "SPECIAL TOOL ASSY (41399FG001)".</p> </div>

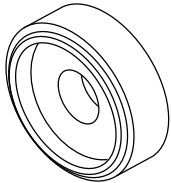
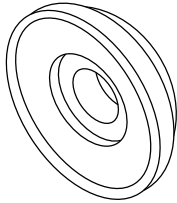
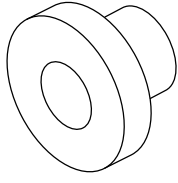
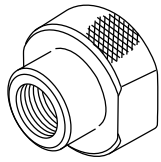
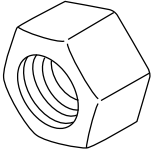
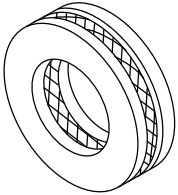
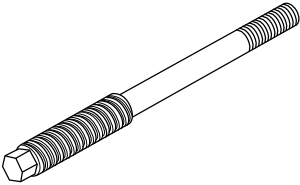

ILLUSTRATION	TOOL NUMBER	DESCRIPTION	REMARKS
 <p data-bbox="298 506 433 527">ST41399FG031</p>	41399FG031	SPECIAL TOOL C	<p data-bbox="935 191 1433 258">Used for removing the rear differential mount bushing.</p> <div data-bbox="935 264 1433 422" style="border: 1px solid black; padding: 5px;"> <p data-bbox="935 268 1016 296">Note:</p> <p data-bbox="959 306 1409 415">For combination of tools, refer to "SPECIAL TOOL ASSY (41399FG001)".</p> </div>
 <p data-bbox="298 871 433 892">ST41399FG041</p>	41399FG041	SPECIAL TOOL D	<p data-bbox="935 558 1433 625">Used for installing the rear differential mount bushing.</p> <div data-bbox="935 632 1433 789" style="border: 1px solid black; padding: 5px;"> <p data-bbox="935 636 1016 663">Note:</p> <p data-bbox="959 674 1409 783">For combination of tools, refer to "SPECIAL TOOL ASSY (41399FG001)".</p> </div>
 <p data-bbox="298 1239 433 1260">ST41399FG050</p>	41399FG050	SPECIAL TOOL SLEEVE	<p data-bbox="935 926 1409 993">Used for removing and installing the rear differential mount bushing.</p> <div data-bbox="935 999 1433 1157" style="border: 1px solid black; padding: 5px;"> <p data-bbox="935 1003 1016 1031">Note:</p> <p data-bbox="959 1041 1409 1150">For combination of tools, refer to "SPECIAL TOOL ASSY (41399FG001)".</p> </div>
 <p data-bbox="298 1606 433 1627">ST41399FG061</p>	41399FG061	SPECIAL TOOL RING	<p data-bbox="935 1293 1409 1360">Used for removing and installing the rear differential mount bushing.</p> <div data-bbox="935 1367 1433 1524" style="border: 1px solid black; padding: 5px;"> <p data-bbox="935 1371 1016 1398">Note:</p> <p data-bbox="959 1409 1409 1518">For combination of tools, refer to "SPECIAL TOOL ASSY (41399FG001)".</p> </div>

ILLUSTRATION	TOOL NUMBER	DESCRIPTION	REMARKS
 <p>ST41399FG070</p>	41399FG070	SPECIAL TOOL NUT	<p>Used for removing and installing the rear differential mount bushing.</p> <p>Note: For combination of tools, refer to "SPECIAL TOOL ASSY (41399FG001)".</p>
 <p>ST41399FG080</p>	41399FG080	SPECIAL TOOL BEARING	<p>Used for removing and installing the rear differential mount bushing.</p> <p>Note: For combination of tools, refer to "SPECIAL TOOL ASSY (41399FG001)".</p>
 <p>ST41399FG091</p>	41399FG091	SPECIAL TOOL SHAFT	<p>Used for removing and installing the rear differential mount bushing.</p> <p>Note: For combination of tools, refer to "SPECIAL TOOL ASSY (41399FG001)".</p>
 <p>STSSM4</p>	—	SUBARU SELECT MONITOR 4	<p>Used for setting of each function and troubleshooting for electrical system.</p> <p>Note:</p> <ul style="list-style-type: none"> • For detailed operation procedures, refer to "Help" of application. • Used together with interface for Subaru Select Monitor (such as DST-i and DST-010).

2. GENERAL TOOL

TOOL NAME	REMARKS
Thickness gauge	Used for various inspections.
Spring scale	Used for measuring the initial load.
Crowbar	Used for removing the rear drive shaft.
Angle gauge	Used for angle tightening.
Dial gauge	<ul style="list-style-type: none"><li data-bbox="781 451 1442 485">• Used for measuring backlash. (Spindle type) <div data-bbox="813 489 1442 569" style="border: 1px solid black; padding: 2px;"><p data-bbox="813 495 1442 569">Note: Used together with magnet stand.</p></div> <ul style="list-style-type: none"><li data-bbox="781 573 1442 648">• Used for measuring the companion flange runout. (Lever type) <div data-bbox="813 653 1442 730" style="border: 1px solid black; padding: 2px;"><p data-bbox="813 659 1442 730">Note: Used together with magnet stand.</p></div>
Magnet stand	<ul style="list-style-type: none"><li data-bbox="781 737 1442 770">• Used for measuring backlash. <div data-bbox="813 774 1442 892" style="border: 1px solid black; padding: 2px;"><p data-bbox="813 781 1442 892">Note: Used together with the dial gauge (spindle type).</p></div> <ul style="list-style-type: none"><li data-bbox="781 896 1442 972">• Used for measuring the companion flange runout. <div data-bbox="813 976 1442 1092" style="border: 1px solid black; padding: 2px;"><p data-bbox="813 982 1442 1092">Note: Used together with the dial gauge (lever type).</p></div>

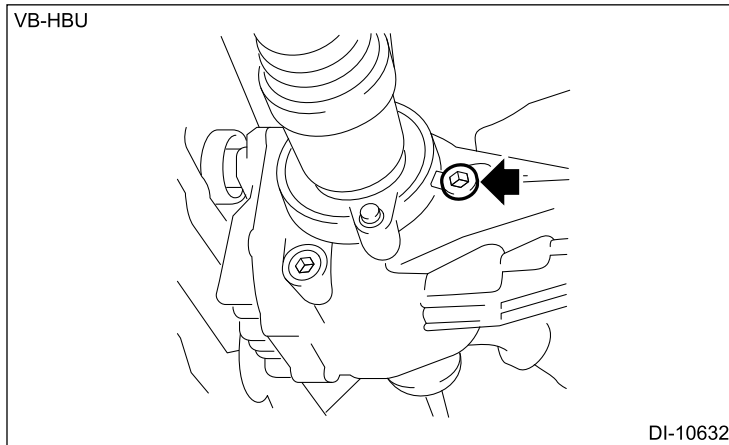
DIFFERENTIALS > Differential Gear Oil

INSPECTION

Caution:

If the differential gear oil is spilt over exhaust pipe, etc., wipe it off to avoid emitting smoke or causing a fire.

1. Remove the filler plug.



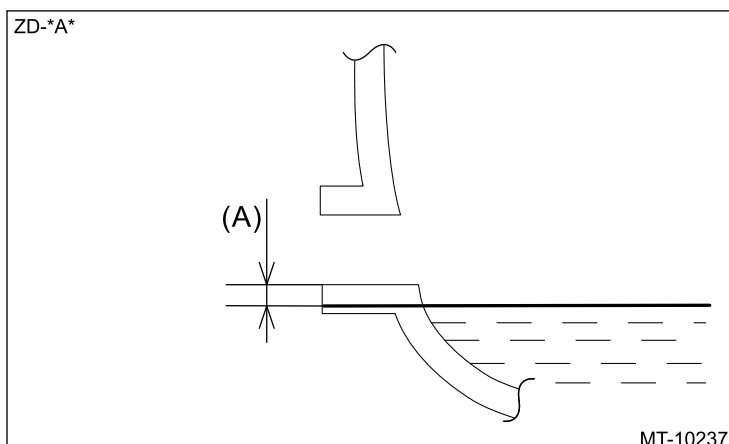
2. Check the differential gear oil.
Replace the differential gear oil if it is degraded, clouded or contaminated. [🔗 Ref. to DIFFERENTIALS>Differential Gear Oil>REPLACEMENT.](#)
3. Check that the differential gear oil level is within 5 mm (0.2 in) from the bottom of the filler plug hole. If the differential gear oil level is low, make sure that there is no oil leakage and refill up to the bottom of filler plug hole.

Note:

- Excessive or insufficient differential gear oil level causes failures.
- Perform inspection with the vehicle being level.
- Fill the differential gear oil until it flow out of the filler plug hole and wait the outflow to stop.

Preparation items:

Differential gear oil: [🔗 Ref. to DIFFERENTIALS>General Description>SPECIFICATION > DIFFERENTIAL GEAR OIL.](#)



(A) 5 mm (0.2 in)

4. Using a new gasket, install the filler plug.

Tightening torque:

50 N·m (5.1 kgf-m, 36.9 ft-lb)

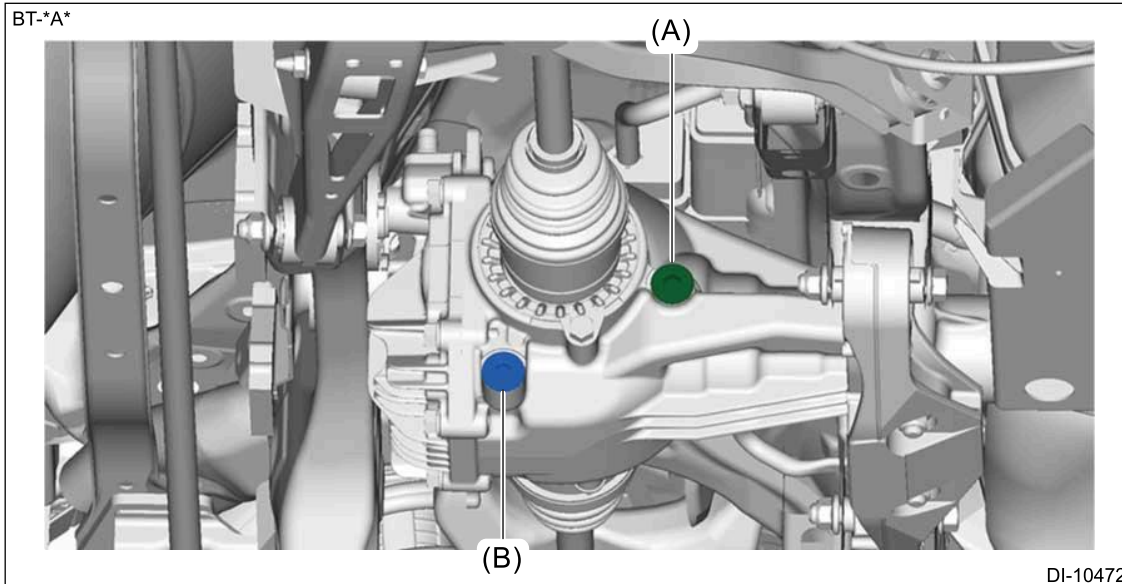
DIFFERENTIALS > Differential Gear Oil

REPLACEMENT

Caution:

If the differential gear oil is spilt over exhaust pipe, etc., wipe it off to avoid emitting smoke or causing a fire.

1. Remove the filler plug (A).
2. Remove the drain plug (B), and drain differential gear oil.



3. Remove the iron powder, etc. from the drain plug.
4. Install the drain plug using a new gasket.
Tightening torque:
50 N·m (5.1 kgf-m, 36.9 ft-lb)
5. Fill the differential gear oil to the bottom of filler plug hole.

Note:

Fill the differential gear oil until it flow out of the filler plug hole and wait the outflow to stop.

Preparation items:

Differential gear oil:  [Ref. to DIFFERENTIALS>General Description>SPECIFICATION > DIFFERENTIAL GEAR OIL.](#)

6. Using a new gasket, install the filler plug.

Tightening torque:

50 N·m (5.1 kgf-m, 36.9 ft-lb)

DIFFERENTIALS > Front Differential

SPECIFICATION

1. MT MODEL

For the front differential, refer to the "MANUAL TRANSMISSION AND DIFFERENTIAL (TY75)".

 [Ref. to MANUAL TRANSMISSION AND DIFFERENTIAL\(TY75\)>Front Differential.](#)

2. CVT MODEL




For the front differential, refer to the "CONTINUOUSLY VARIABLE TRANSMISSION (TR690)".

 [Ref. to CONTINUOUSLY VARIABLE TRANSMISSION\(TR690\)>Drive Pinion.](#)

DIFFERENTIALS > Rear Differential (VB-type)

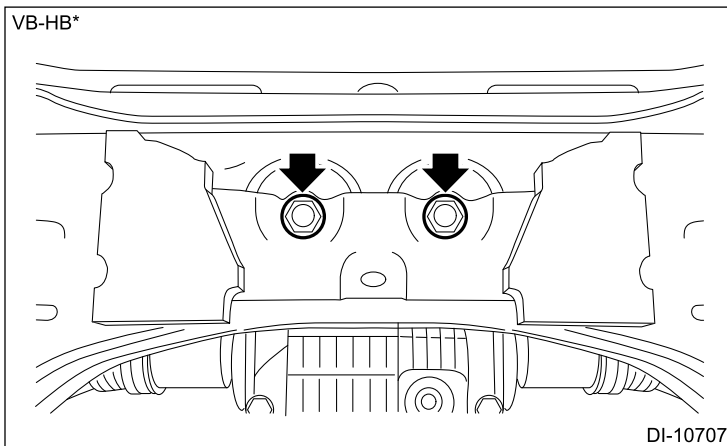
REMOVAL



1. Release the parking brake.
2. Release the shift lock and shift the select lever to the "N range". (CVT model)  Ref. to [CONTROL SYSTEMS>Select Lever>REMOVAL](#).
3. Drain differential gear oil.  Ref. to [DIFFERENTIALS>Differential Gear Oil>REPLACEMENT](#).
4. Remove the propeller shaft.  Ref. to [PROPELLER SHAFT / DRIVE SHAFT / AXLE>Propeller Shaft>REMOVAL](#).
5. Loosen the self-locking nuts which hold the rear differential.

Caution:

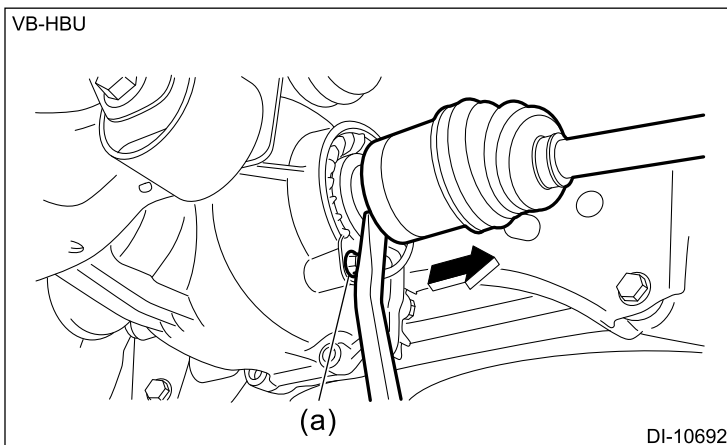
Do not over-loosen the self-locking nut because the rear differential may fall off.



6. Using a crowbar, etc., disengage the rear drive shaft.

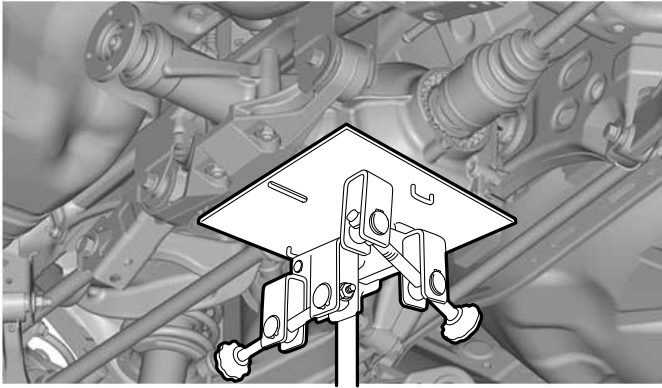
Caution:

Crowbar, etc. must keep in contact with the bolt (a) securing the lock plate.



7. Set the transmission jack.

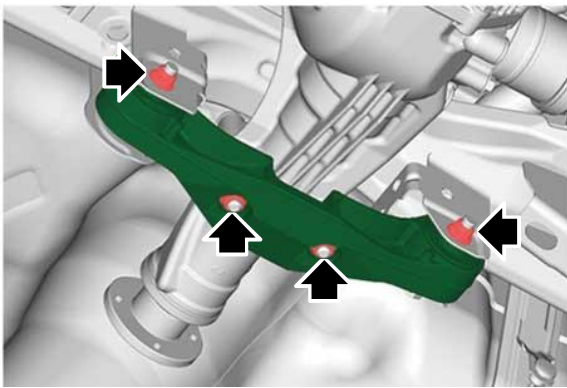
VB-HB*



DI-10721

8. Remove the rear differential front member.

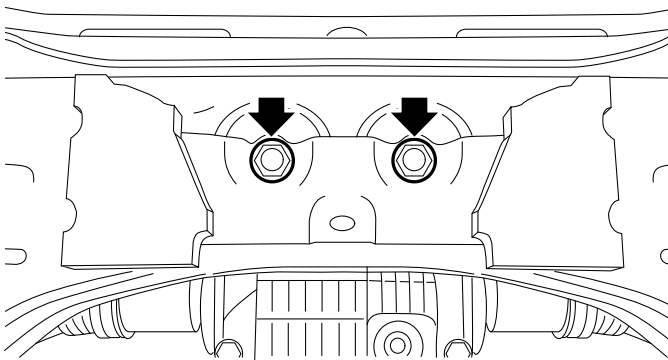
VB-HB*



DI-10722

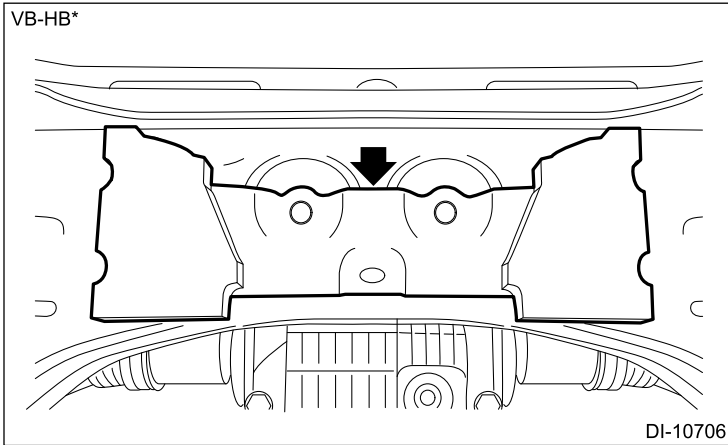
9. Remove the self-locking nut.

VB-HB*



DI-10707

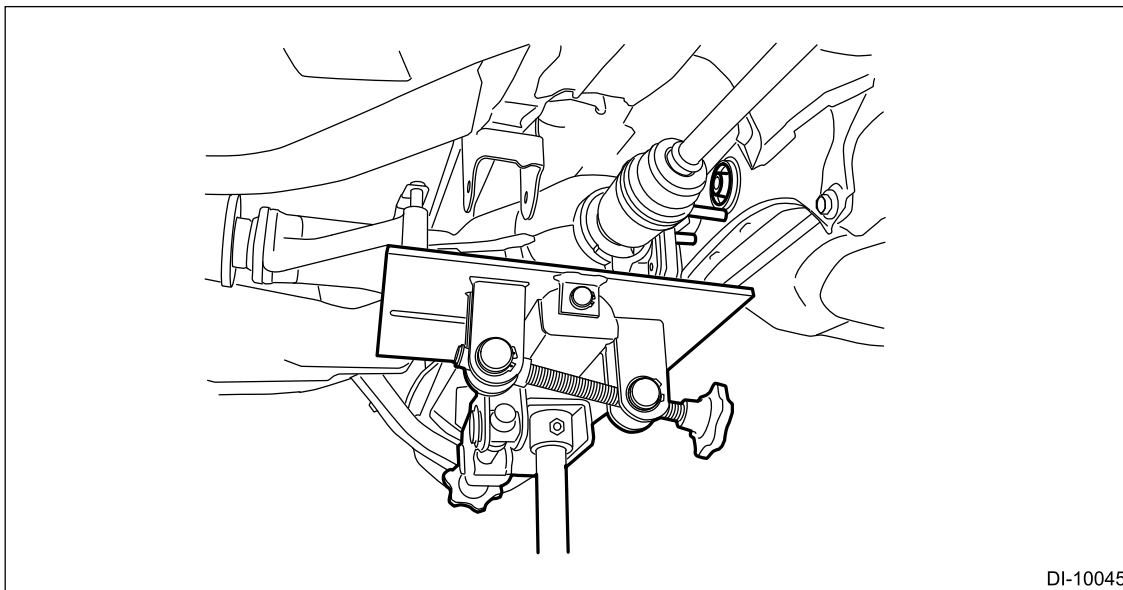
10. Remove the mass damper. (CVT model)



11. Remove the stud bolt.


Note:

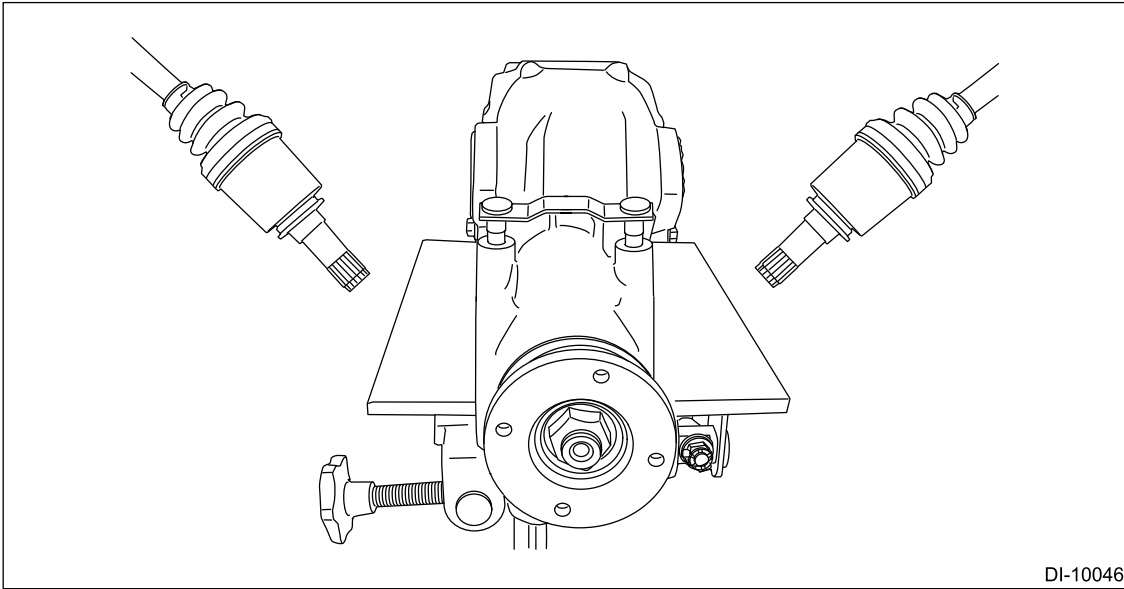
Adjust the position and angle of the transmission jack if necessary.



12. Lower the transmission jack, pull out the rear drive shaft and remove the rear differential.

Caution:

If the circlip is adhered to the rear drive shaft, overhaul the differential case.  [Ref. to DIFFERENTIALS>Rear Differential \(VB-type\)>DISASSEMBLY.](#)



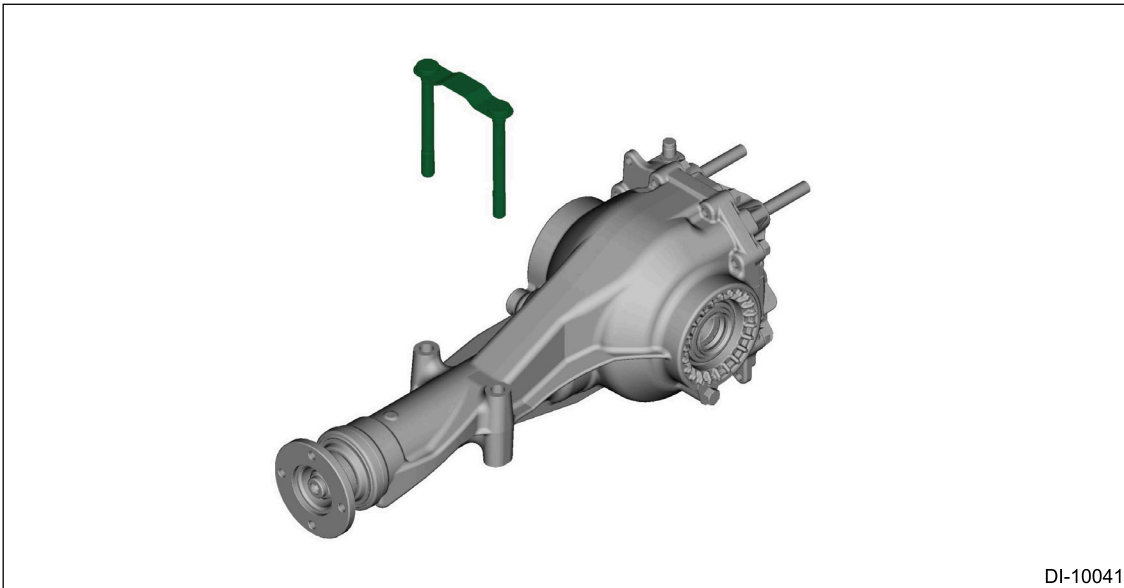
DI-10046

13. Hang the rear drive shaft with a string, etc.

Note:

This is necessary to prevent damage of the rear drive shaft.

14. Remove the rear differential member plate.




DI-10041

DIFFERENTIALS > Rear Differential (VB-type)

INSTALLATION

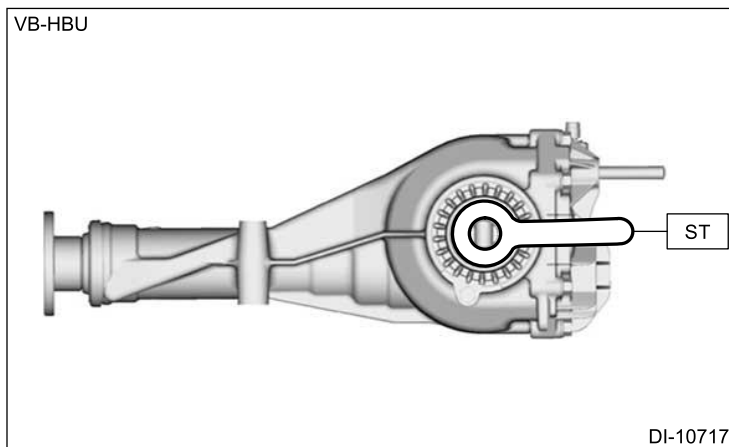
Caution:

Use a rear differential as specified.

1. Replace with a new differential side retainer oil seal.  [Ref. to DIFFERENTIALS>Differential Side Retainer Oil Seal>REPLACEMENT.](#)
2. Set the rear differential member plate to the rear differential.
3. Set the rear differential to transmission jack.
4. Apply differential gear oil to the differential side retainer oil seal lip and rear drive shaft insertion section.
5. Set the ST.

Preparation tool:

ST: OIL SEAL PROTECTOR (28099PA090)

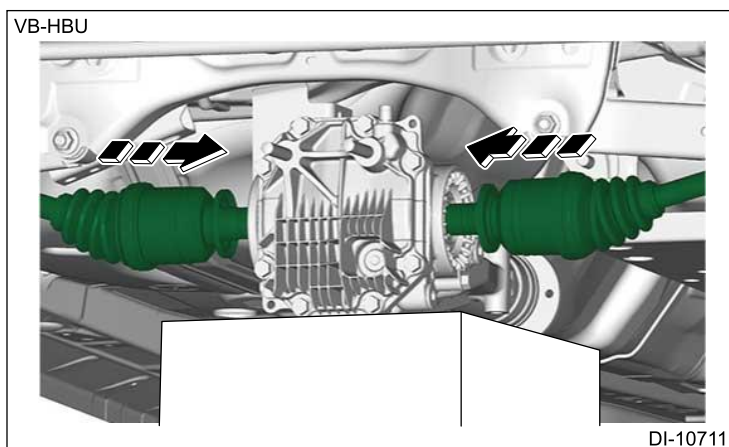


6. Insert the splines of the rear drive shaft into the rear differential and remove the ST.

Note:

Remove it before inserting the rear drive shaft completely.

7. Insert the rear drive shaft completely.



8. Insert the stud bolt into the rear differential mount bushing.

Note:

Adjust the position and angle of the transmission jack if necessary.

9. Set the mass damper to the stud bolt. (CVT model)

10. Temporarily install the self-locking nut.

Caution:

Be sure to use a new self-locking nut.

11. Temporarily install the rear differential front member.

Caution:

Be sure to use a new self-locking nut.

12. Detach the transmission jack, and tighten the self-locking nut.

Caution:

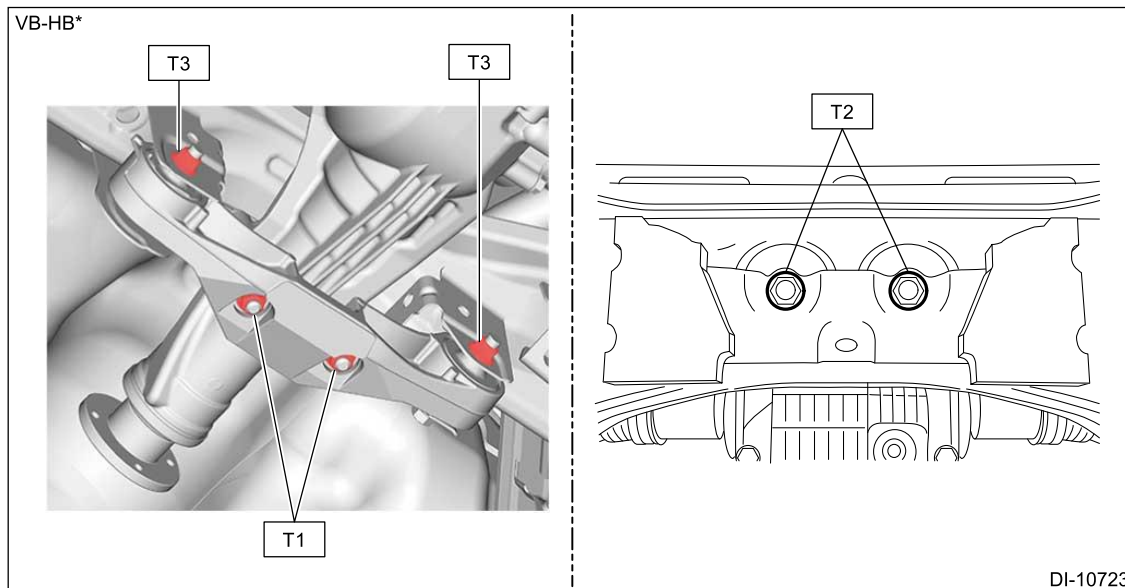
Be sure to detach the transmission jack, and tighten the self-locking nut with the rear differential seated under its own weight.

Tightening torque:

T1: 50 N·m (5.1 kgf-m, 36.9 ft-lb)


T2: 70 N·m (7.1 kgf-m, 51.6 ft-lb)

T3: 110 N·m (11.2 kgf-m, 81.1 ft-lb)



13. Install the propeller shaft.  [Ref. to PROPELLER SHAFT / DRIVE SHAFT / AXLE>Propeller Shaft>INSTALLATION.](#)

14. Fill differential gear oil.  [Ref. to DIFFERENTIALS>Differential Gear Oil>REPLACEMENT.](#)

15. Shift the select lever to "P range". (CVT model)  [Ref. to CONTROL SYSTEMS>Select Lever>INSTALLATION.](#)

16. Apply the parking brake.

DIFFERENTIALS > Rear Differential (VB-type)

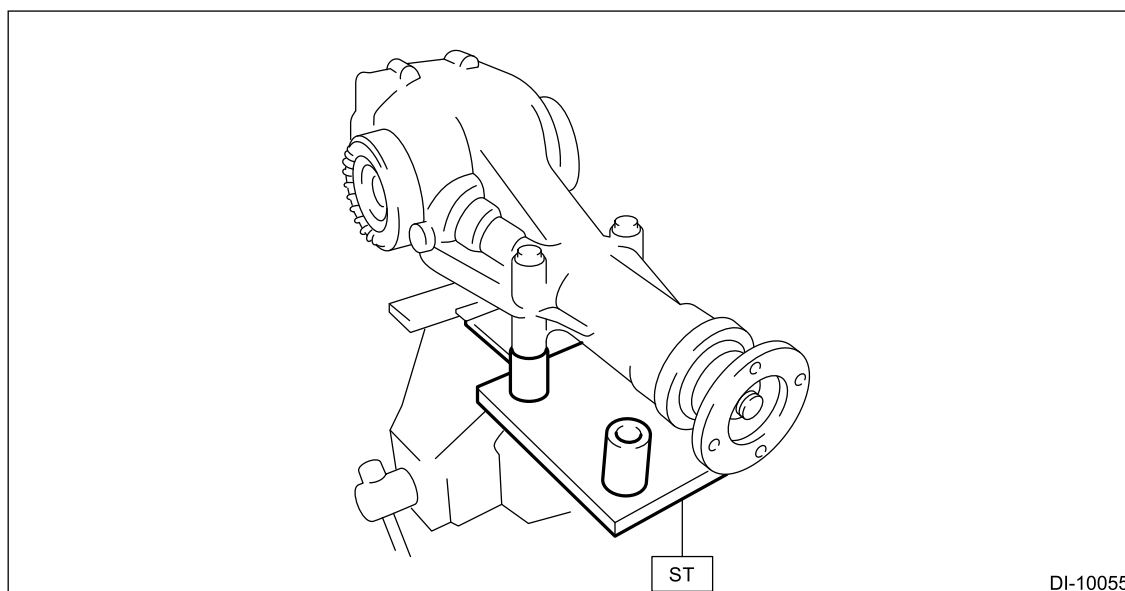
DISASSEMBLY



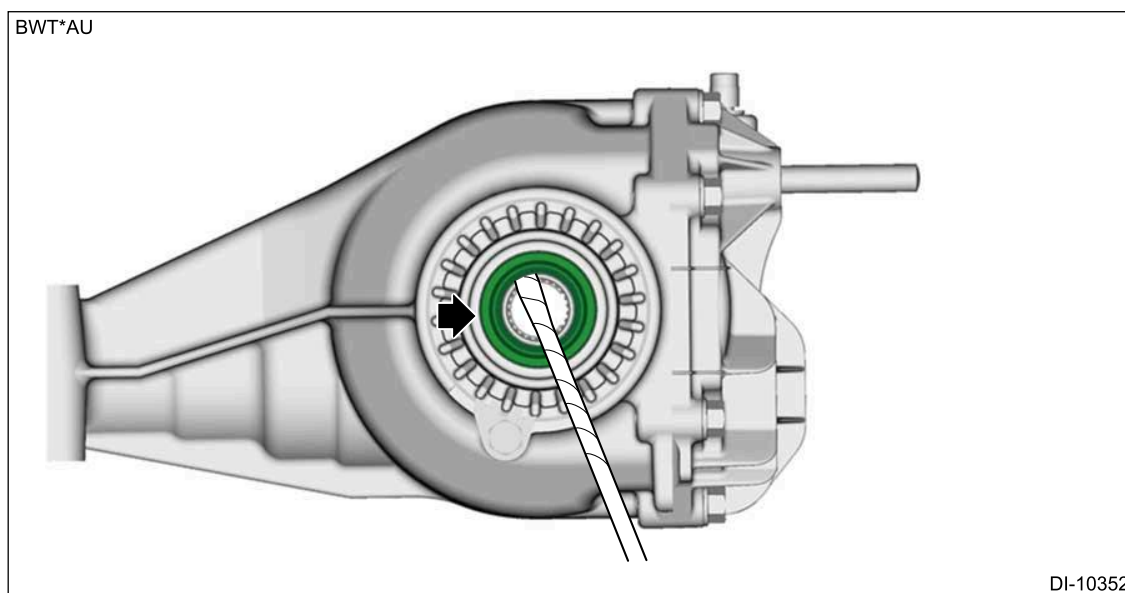
1. Set the ST on vise and install the rear differential.

Preparation tool:

ST: ATTACHMENT SET (398217700)



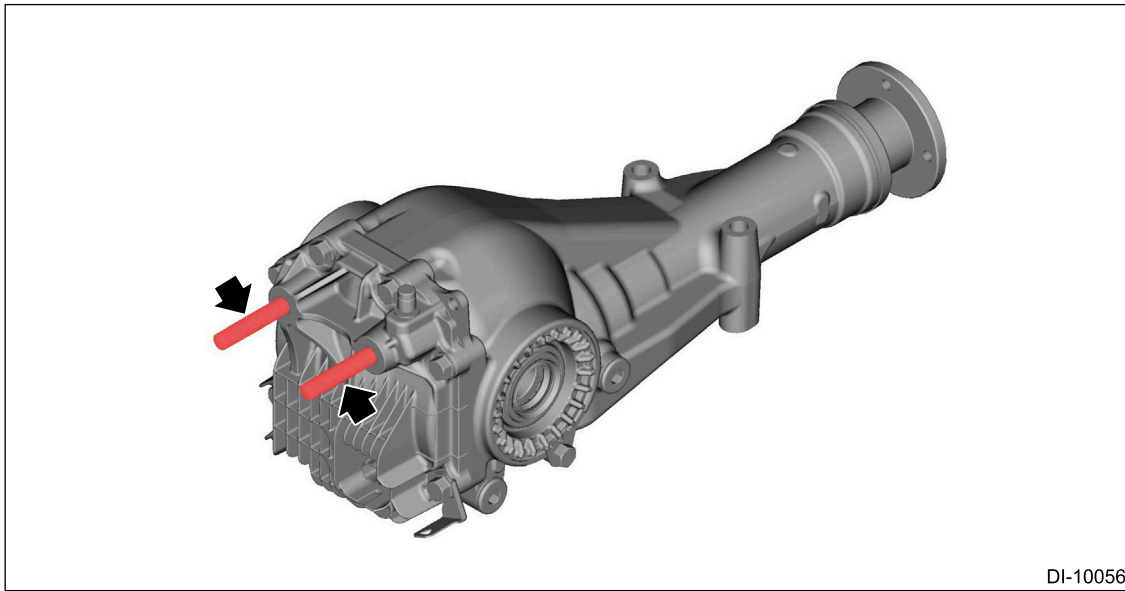
2. Remove the differential side retainer oil seal using a flat tip screwdriver wrapped with protection tape, etc.



3. Remove the stud bolt.

Note:

Perform this procedure only when required.



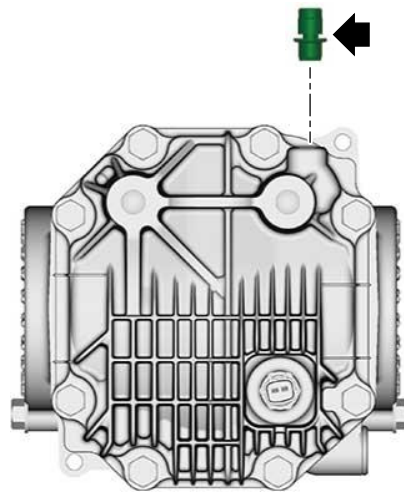
DI-10056

4. Remove the air breather cap.

Note:

Perform this procedure only when required.

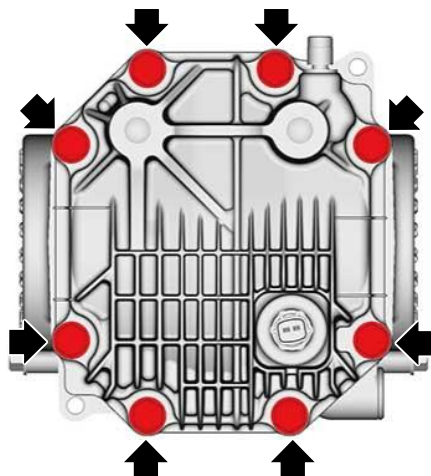
SK-*BE




DI-10441

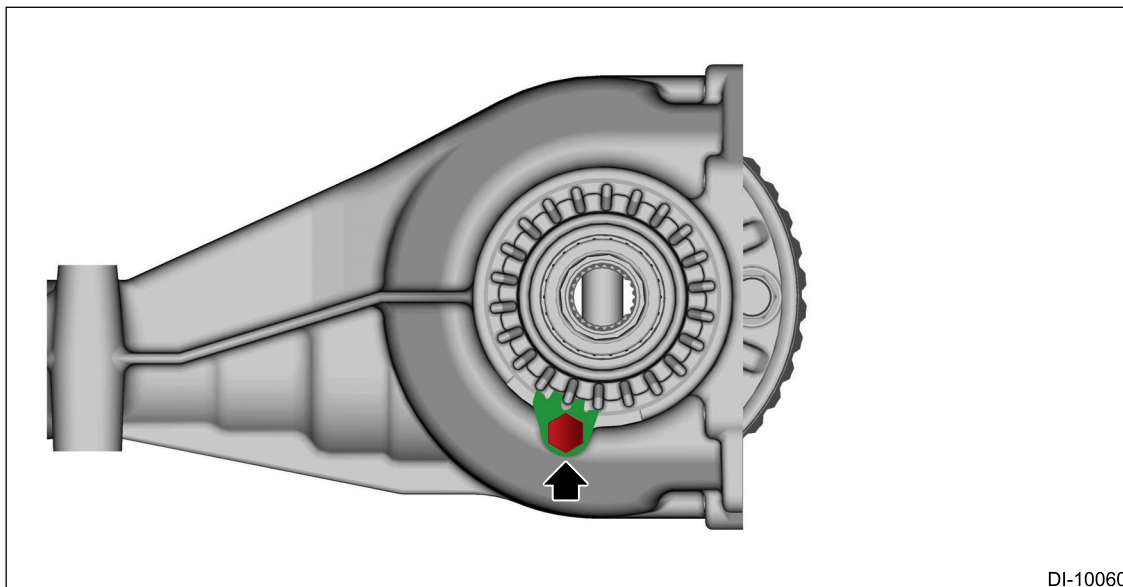
5. Remove the bolts, and remove the rear cover while lightly tapping with a plastic hammer.

SK-*BE



DI-10442

6. Measure and record the tooth contact and backlash of hypoid gear set.  [Ref. to DIFFERENTIALS>Rear Differential \(VB-type\)>ASSEMBLY.](#)
7. Remove the lock plate.



DI-10060

8. Remove the differential side retainer using the ST.

Caution:

- Be careful not to drop the differential case.
- Be careful not to hit the teeth of driven gear against the differential carrier.

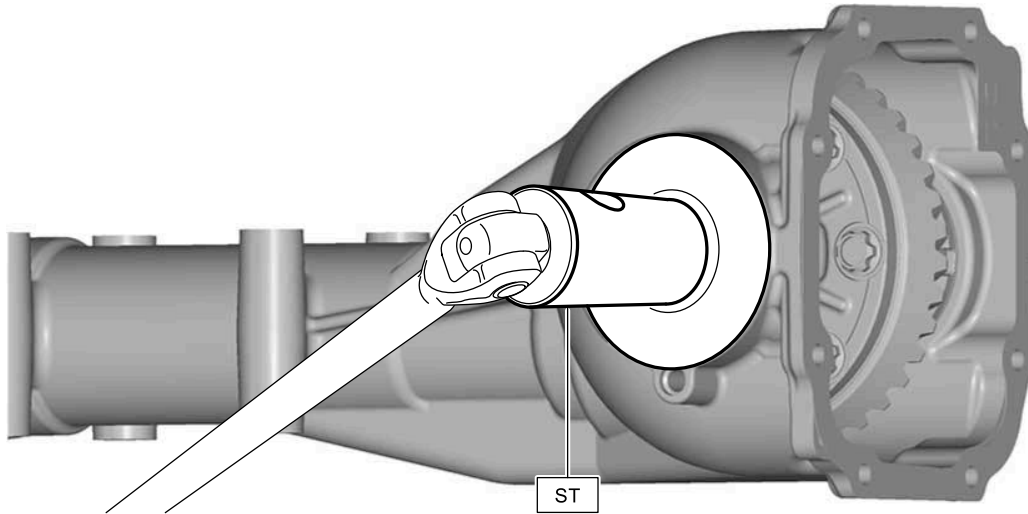
Note:

When there is no replacement of side bearing, do not confuse the left and right side.

Preparation tool:

ST: WRENCH COMPL RETAINER (18658AA021)

BWT*AU

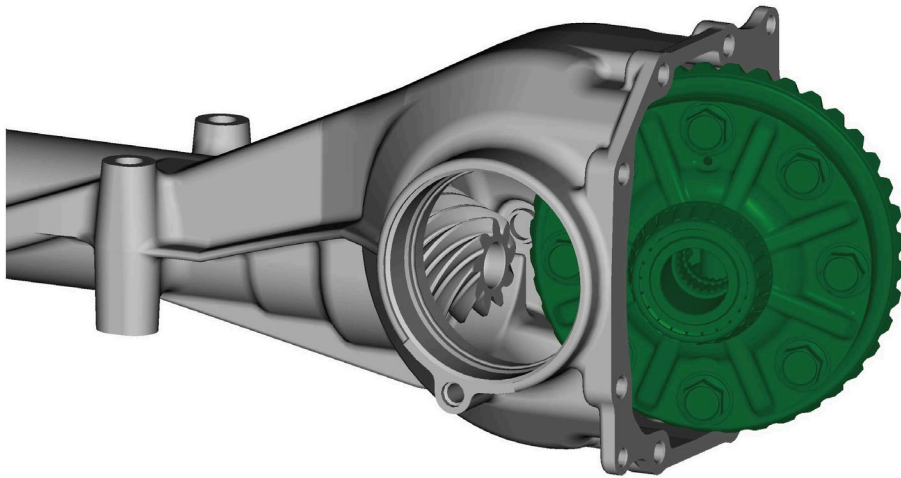


DI-10439

9. Remove the differential case.

Caution:

Be careful not to hit the teeth of driven gear against the differential carrier.



DI-10062

10. Remove the side bearing outer race using ST1 and ST2.

Note:

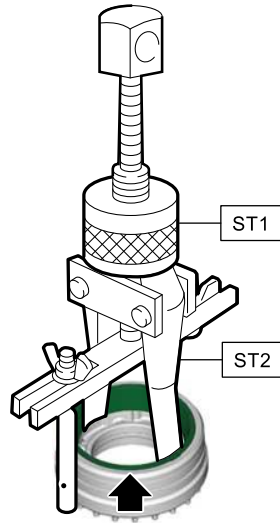
Perform this procedure only when required.

Preparation tool:

ST1: PULLER ASSY (398527700)

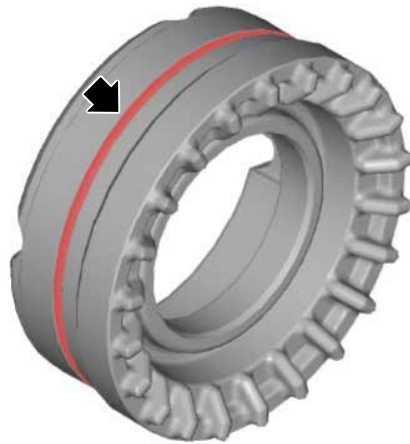
ST2: CLAW (18760AA000)

BWT*AU



DI-10359

11. Remove the O-rings.



DI-10085

12. Remove the side bearing inner race using ST1 and ST2.

Note:

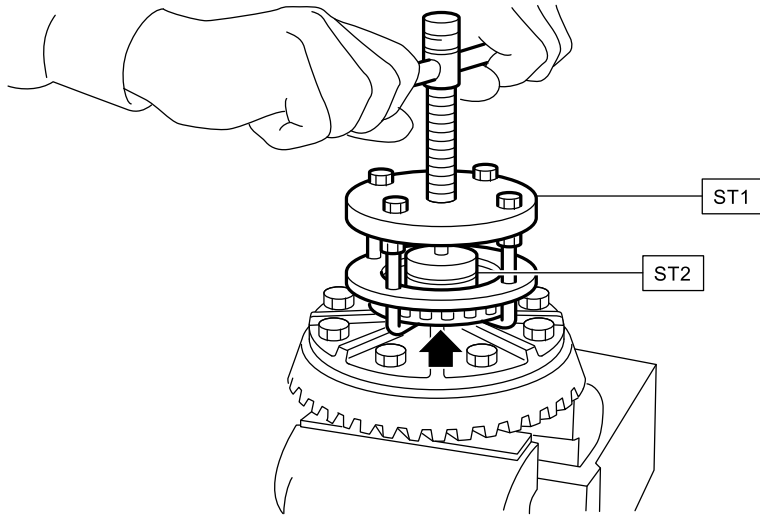
Perform this procedure only when required.

Preparation tool:

ST1: PULLER SET (899524100)

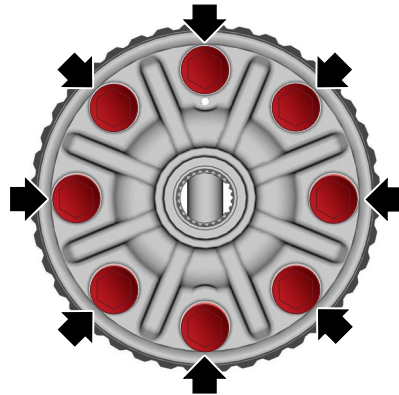
ST2: SEAT (398497701)

BWT*AU



DI-10364

13. Remove the driven gear.

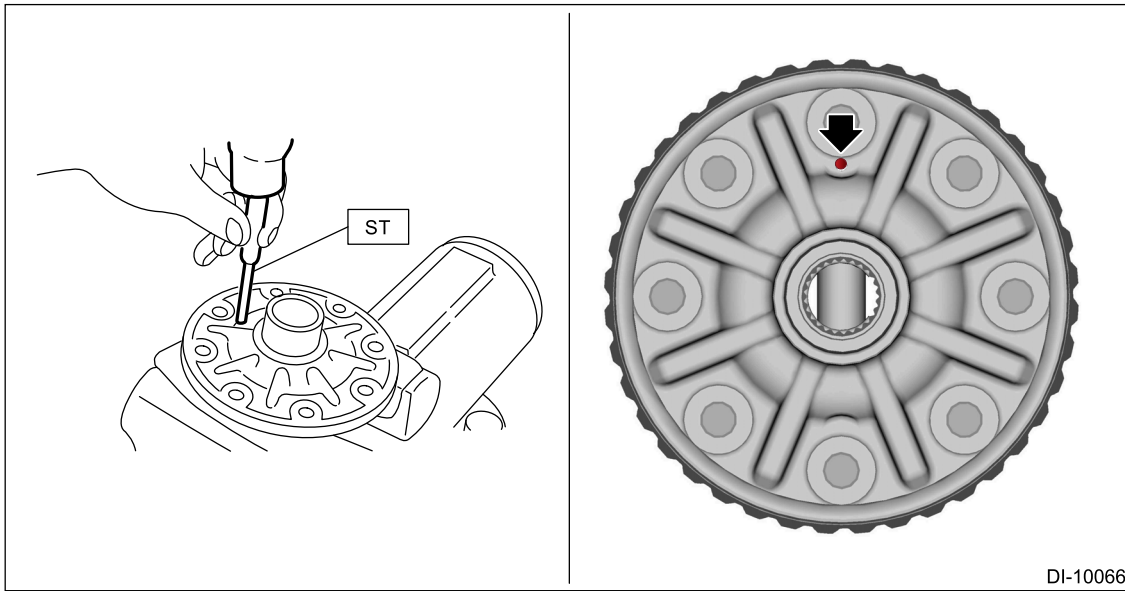


DI-10065

14. Using the ST, remove the spring pin.

Preparation tool:

ST: STRAIGHT PIN REMOVER (899904100)

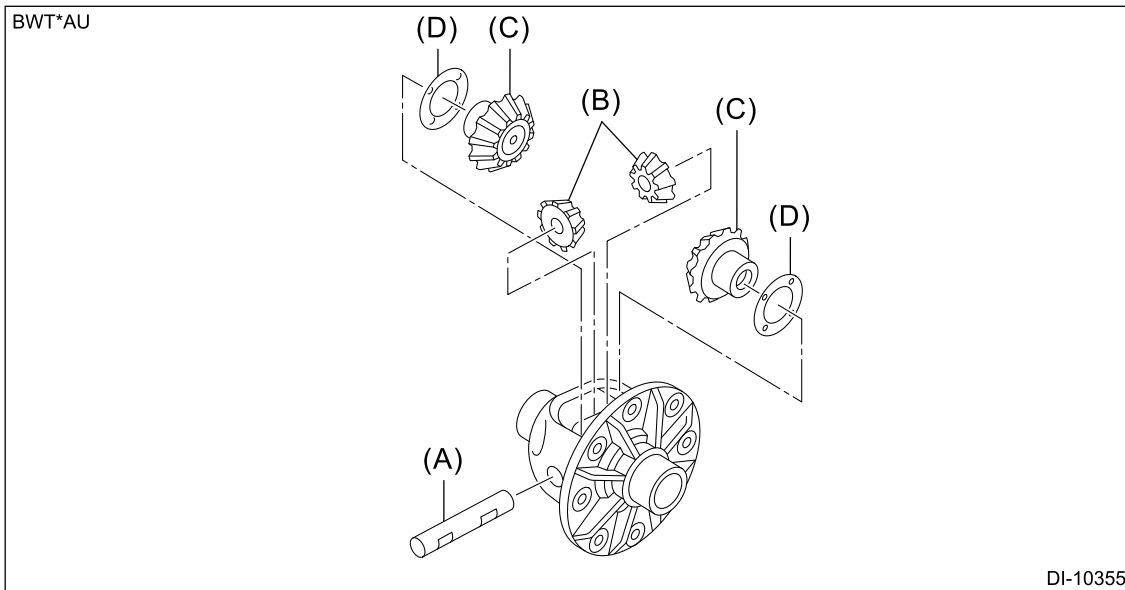


DI-10066

15. Pull out the pinion shaft, and remove the differential bevel pinion, differential bevel gear and thrust washer.

Note:

If each part is reused, do not confuse the installation position.



DI-10355

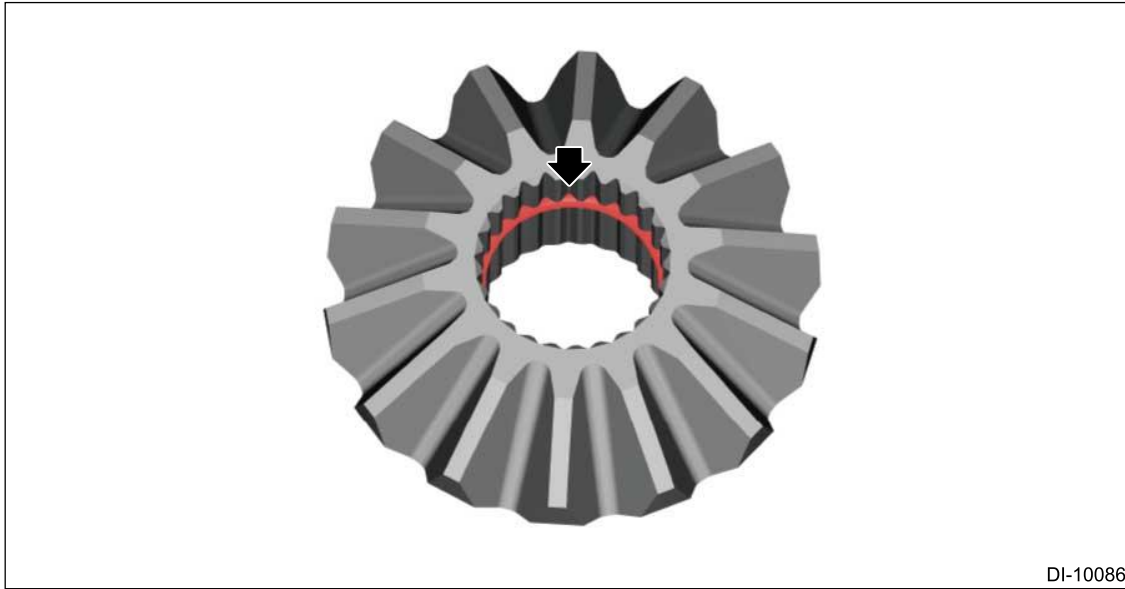
(A) Pinion shaft

(C) Differential bevel gear

(D) Thrust washer

(B) Differential bevel pinion

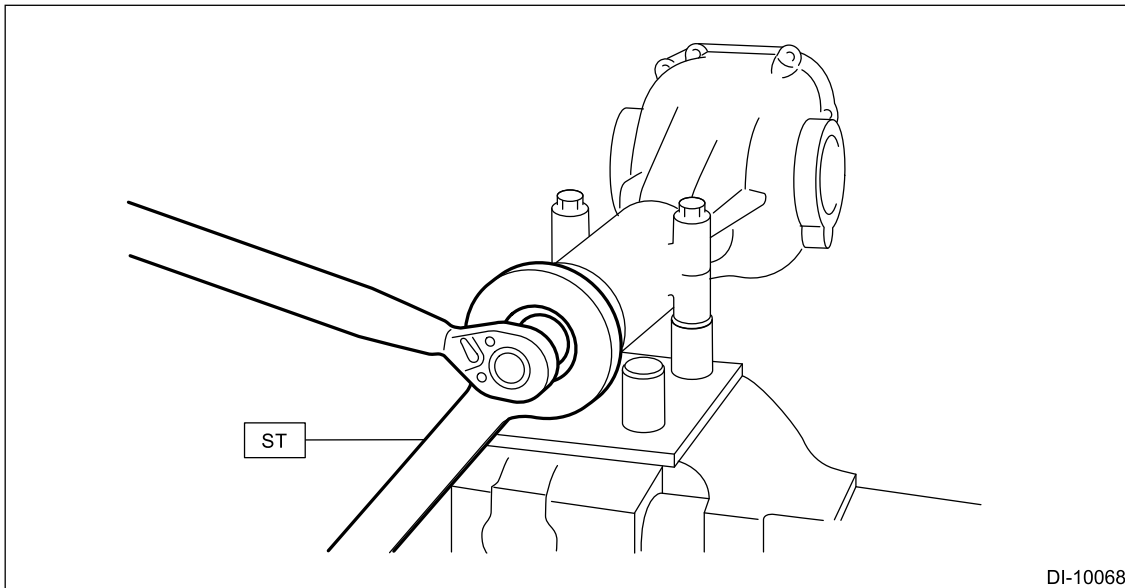
16. Remove the circlips.



17. Remove the self-locking nut while securing the companion flange with ST.

Preparation tool:

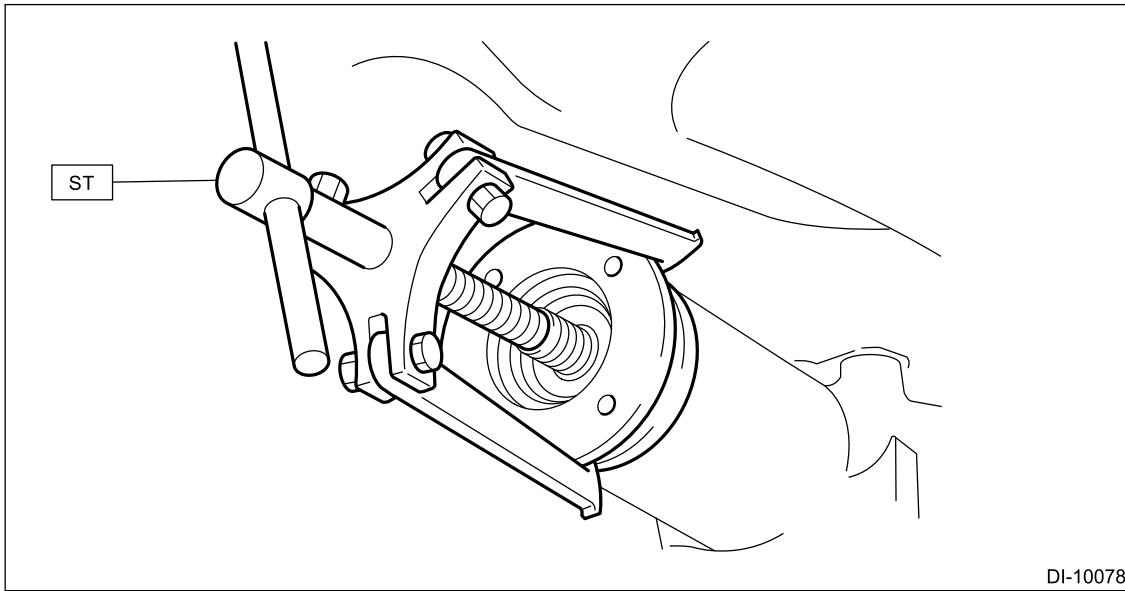
ST: FLANGE WRENCH (498427200)



18. Extract the companion flange using the ST.

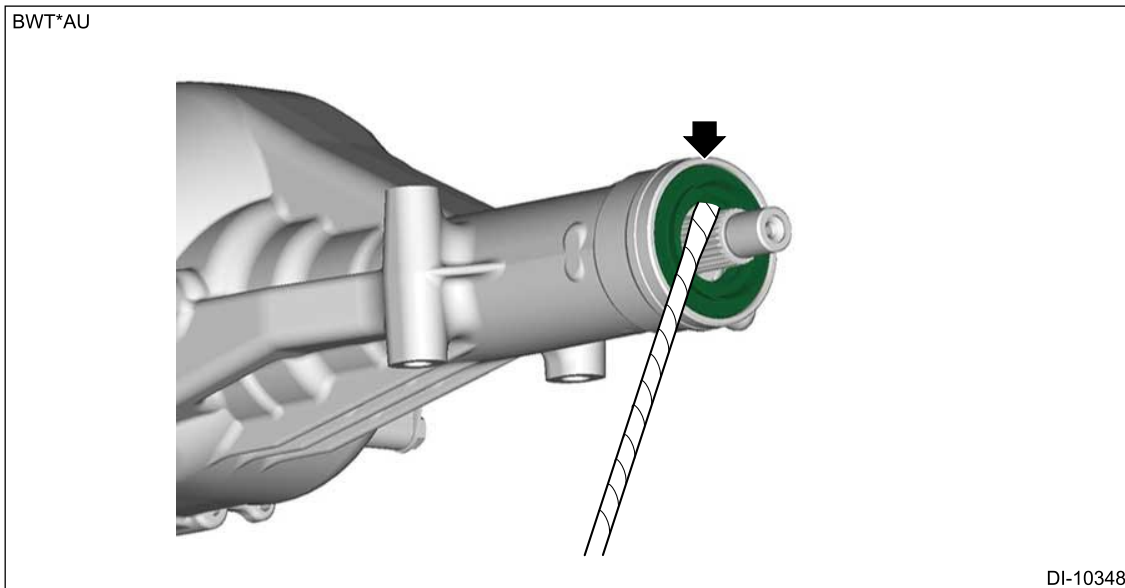
Preparation tool:

ST: PULLER ASSY (399703600)



DI-10078

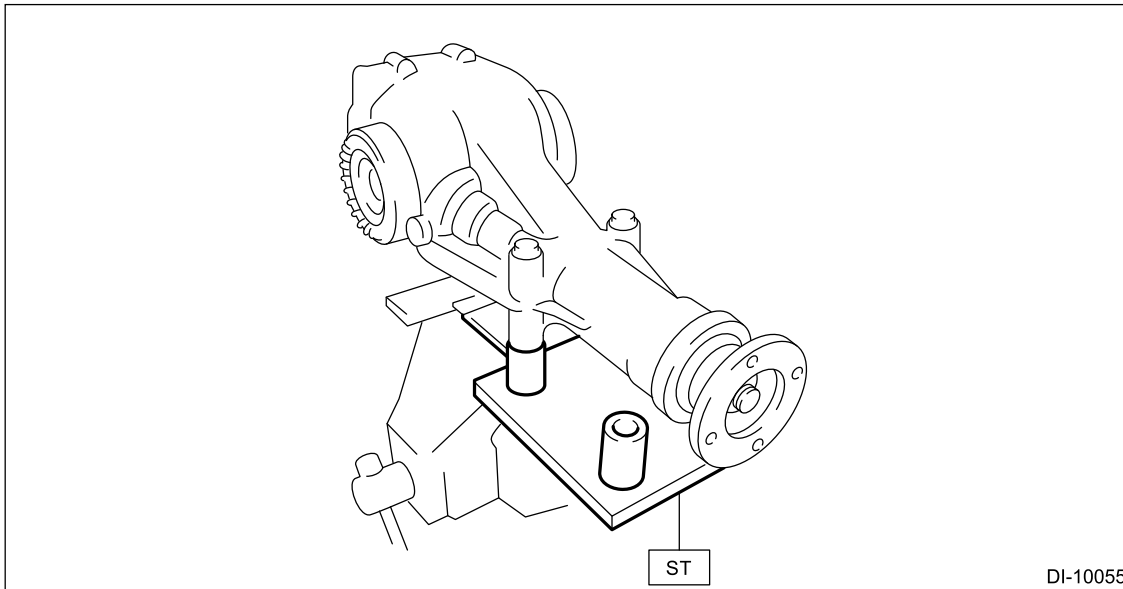
19. Remove the differential front oil seal using a flat tip screwdriver wrapped with protection tape, etc.



DI-10348

20. Remove seal material from the thread portions of the companion flange and drive pinion.

21. Remove the rear differential from ST.

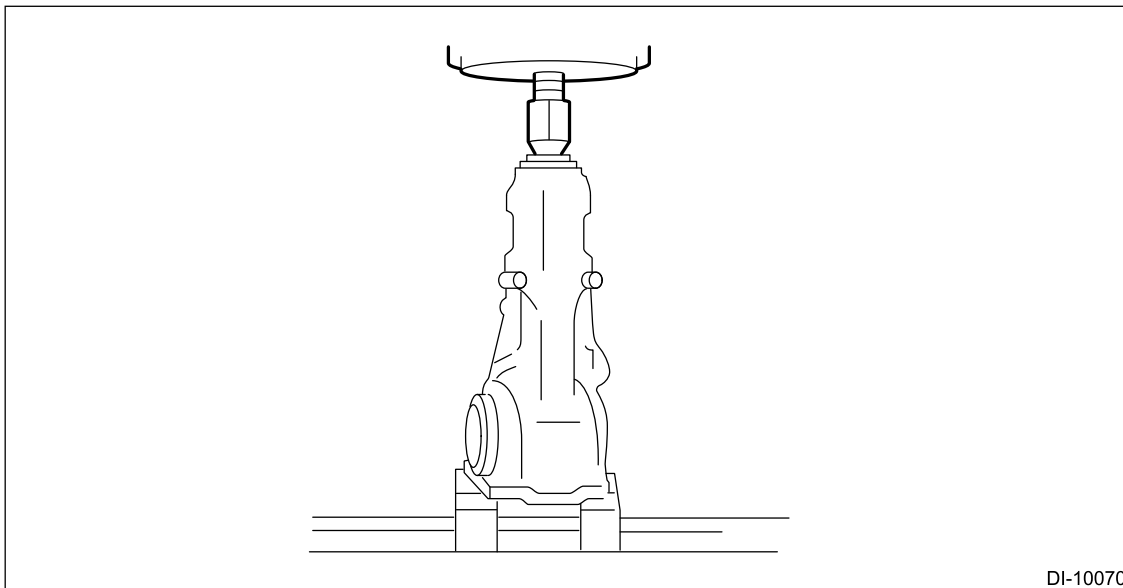


DI-10055

22. Press the end of drive pinion using the press, and remove the drive pinion, pinion height adjusting washer, rear bearing inner race, preload adjusting spacer and preload adjusting washer as a set.

Caution:

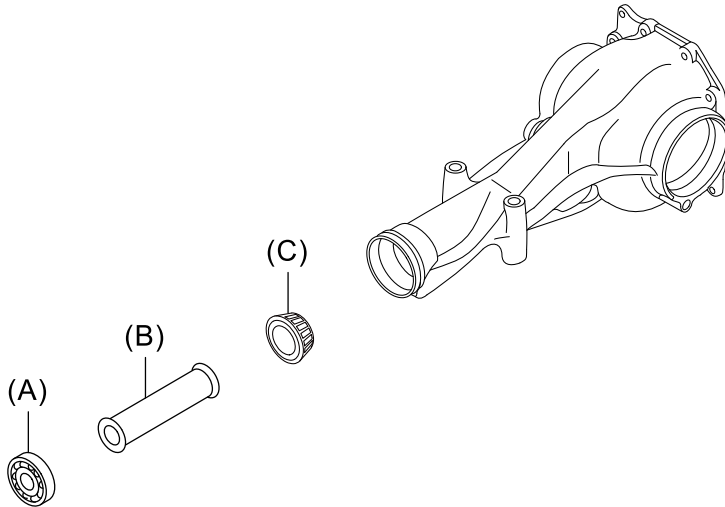
Be careful not to drop the drive pinion.



DI-10070

23. Remove the pilot bearing, spacer and front bearing inner race.

BWT*AU



DI-10360

(A) Pilot bearing

(B) Spacer

(C) Front bearing inner race

24. Remove the rear bearing inner race using the ST and a press.

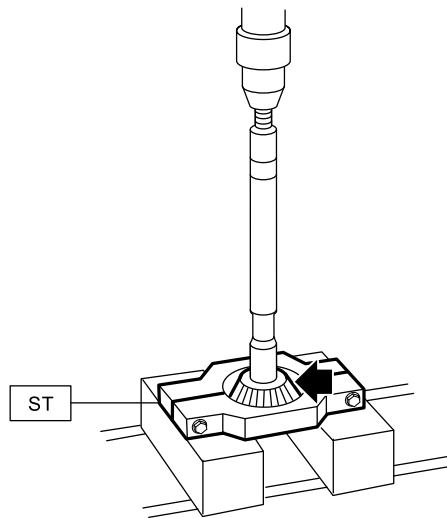
Caution:

Be careful not to drop the drive pinion.

Preparation tool:

ST: REMOVER (18720AA000)

SK-*CJ



DI-10468

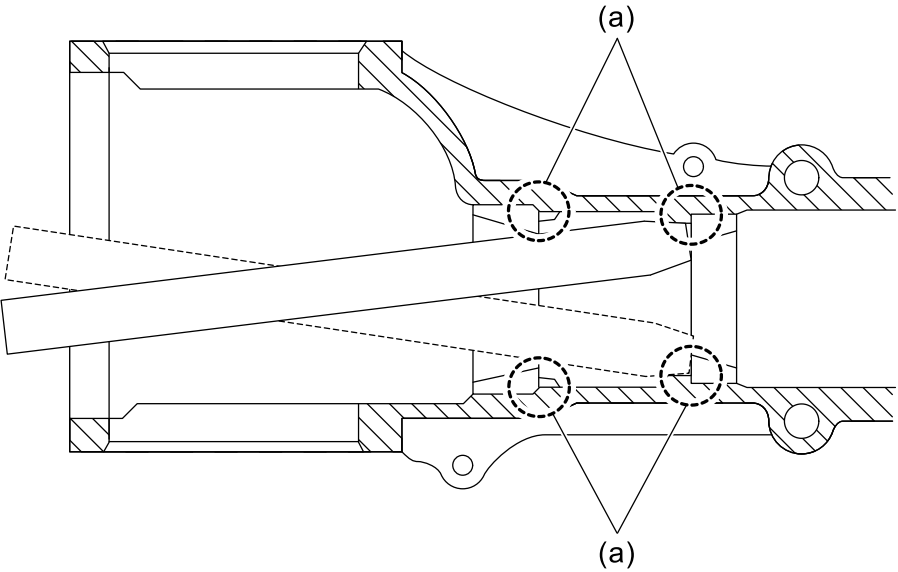
25. Measure and record the thickness of the pinion height adjusting washer.

26. Tap out and remove the front bearing outer race and rear bearing outer race using a brass bar.

Note:

- Remove the front bearing outer race first.
- Tap out the rear bearing outer race from the front side to remove.
- Using the indentation (a) on the differential carrier, tap out the two points alternately to remove.

BWT*AU



DI-10362

DIFFERENTIALS > Rear Differential (VB-type)

ASSEMBLY

1. Adjusting preload for front bearing and rear bearing

Note:

The adjustment must be carried out with the differential front oil seal removed.

(1) Press-fit the new rear bearing outer race (A) using the ST1, ST2 and press.

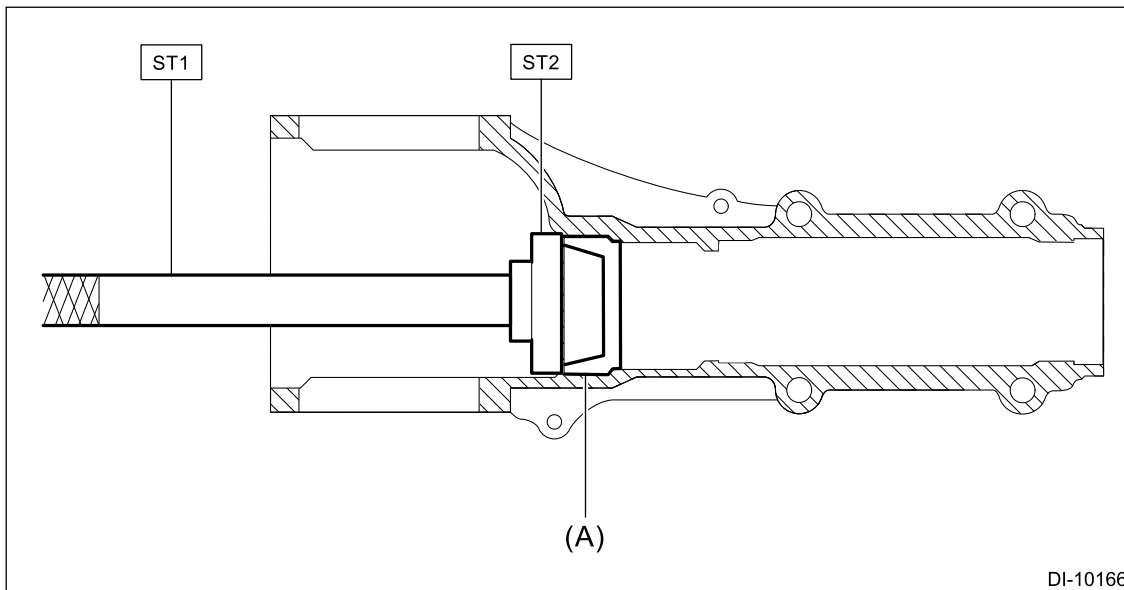
Note:

Apply the differential gear oil to the rear bearing outer race.

Preparation tool:

ST1: HANDLE (398477701)

ST2: DRIFT 2 (398477703)



(2) Press-fit the new front bearing outer race (A) using the ST1, ST2 and press.

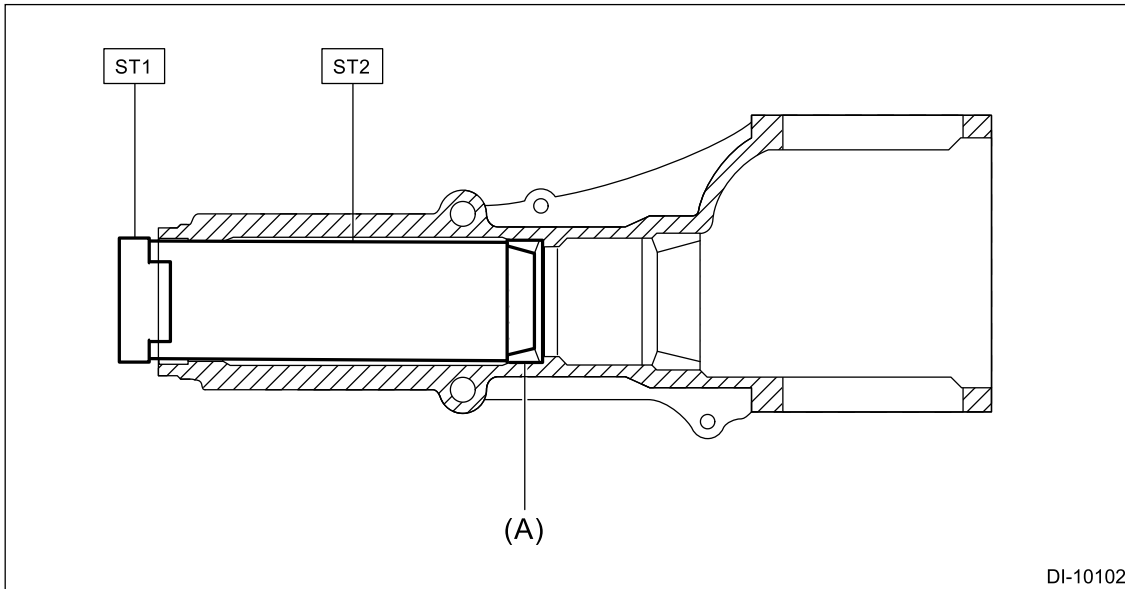
Note:

Apply the differential gear oil to the front bearing outer race.

Preparation tool:

ST1: DRIFT 2 (398477703)

ST2: INSTALLER (18654AA000)



DI-10102

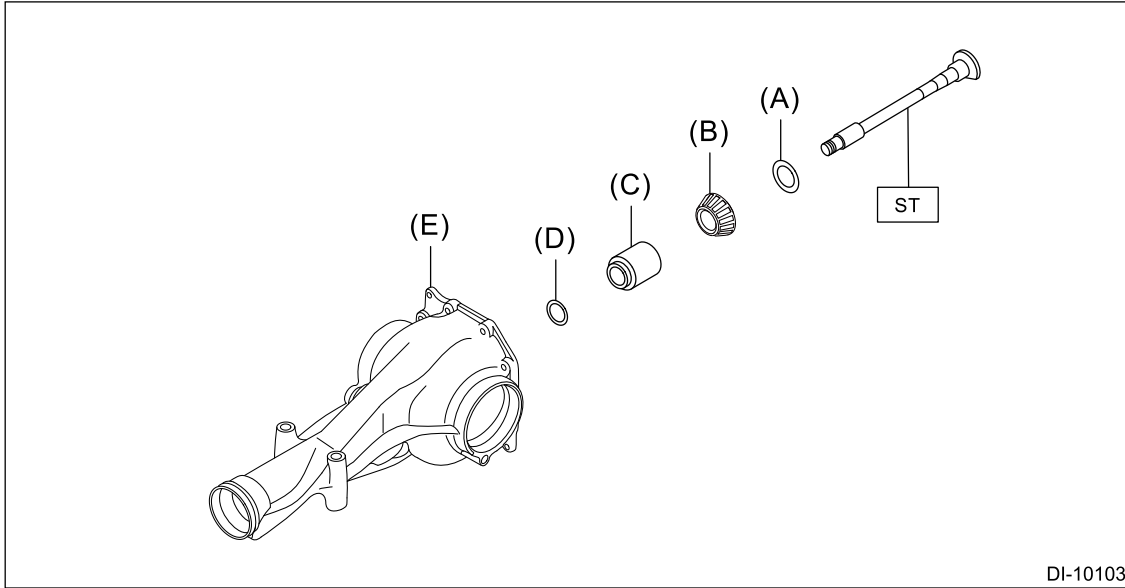
(3) Select the pinion height adjusting washer based on the backlash, tooth contact and pinion height adjusting washer thickness of the hypoid gear set measured when disassembling.

Note:
In the inspection before disassembly, if the backlash and tooth contact of the hypoid gear set are normal, check that the pinion height adjusting washer is not deformed or damaged to reuse it.

(4) Set the pinion height adjusting washer, new rear bearing inner race, preload adjusting spacer and preload adjusting washer on the ST and insert them in the differential carrier.

Note:
Apply the differential gear oil to the rear bearing inner race.

Preparation tool:
 ST: DUMMY SHAFT (18678AA000)



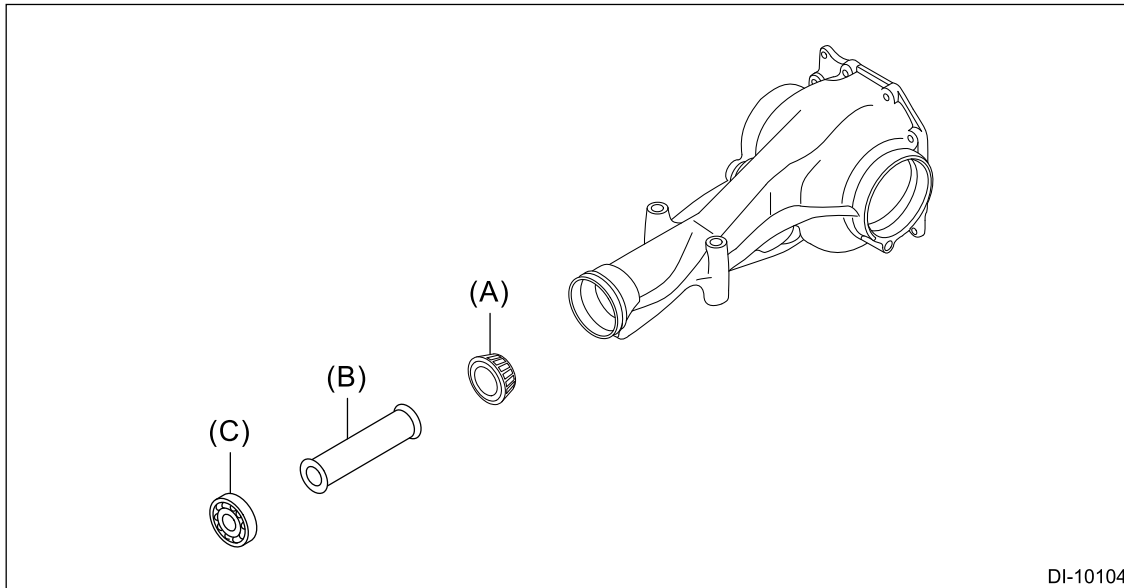
DI-10103

- | | | |
|------------------------------------|------------------------------|--------------------------|
| (A) Pinion height adjusting washer | (C) Preload adjusting spacer | (E) Differential carrier |
| (B) Rear bearing inner race | (D) Preload adjusting washer | |

(5) Set a new front bearing inner race, spacer, and a new pilot bearing.

Note:

Apply the differential gear oil to the front bearing inner race and the pilot bearing.



DI-10104

(A) Front bearing inner race

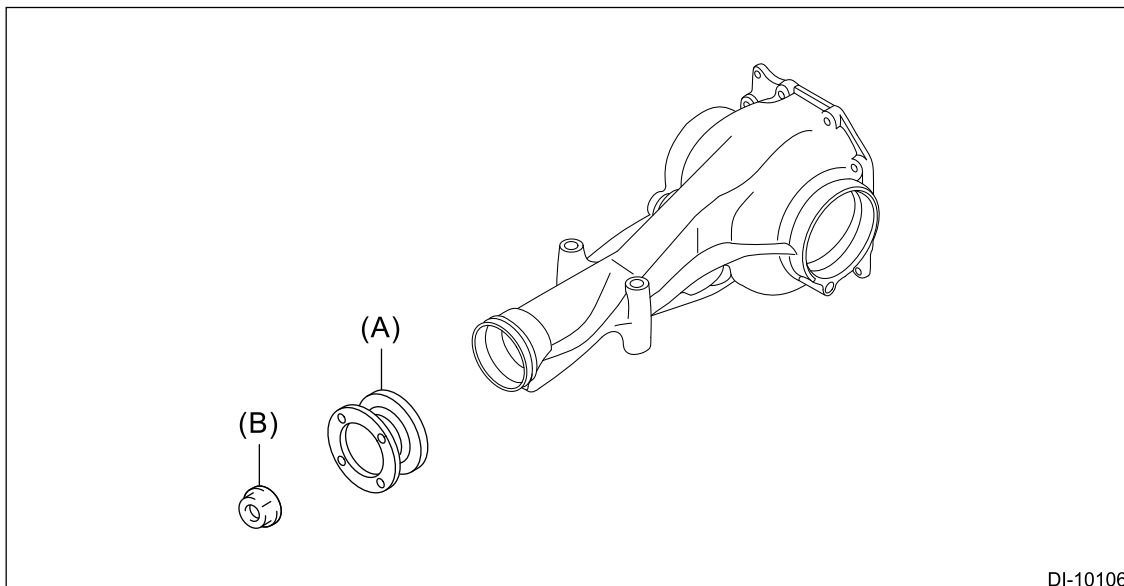
(B) Spacer

(C) Pilot bearing

(6) Set the companion flange and temporarily install the self-locking nut.

Note:

- Use the self-locking nut removed when disassembling.
- Do not install the differential front oil seal.



DI-10106

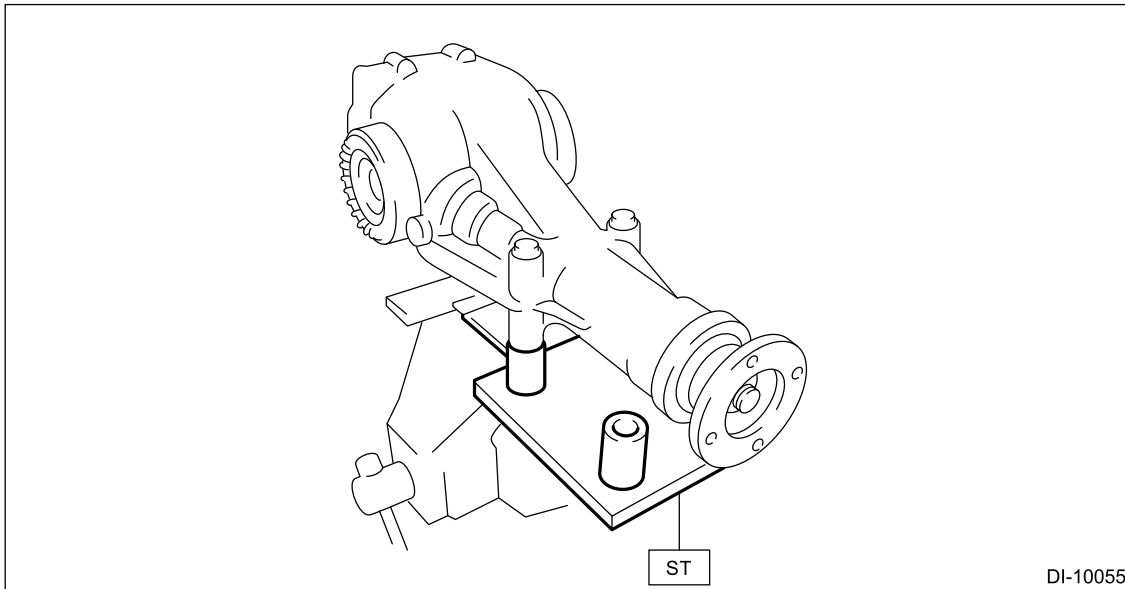
(A) Companion flange

(B) Self-locking nut

(7) Set the ST on vise and install the rear differential.

Preparation tool:

ST: ATTACHMENT SET (398217700)



- (8) Turn the companion flange by hand to smooth each bearing.
- (9) Tighten the self-locking nut while measuring the initial torque or initial load torque with a torque wrench or spring scale.

Caution:

If the initial torque or the initial load exceeds the specification before reaching the tightening torque, immediately stop the tightening.

Note:

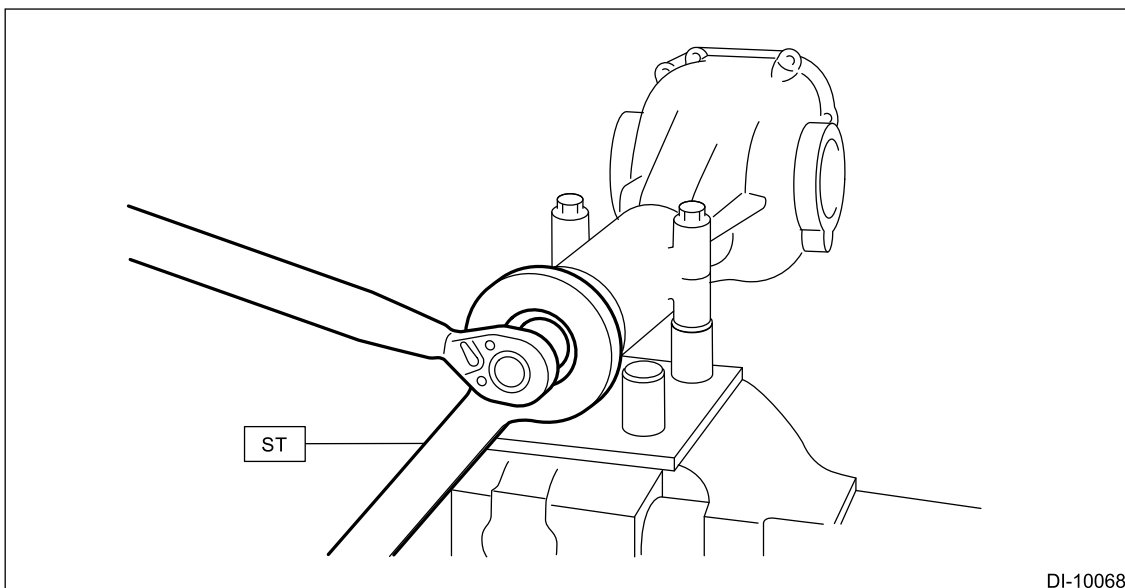
- When tightening the self-locking nut, use the ST to fix the companion flange in place.
- When torque tightening, select the preload adjusting washer and the preload adjusting spacer so that the initial torque or the initial load is within the specification.

Preparation tool:

ST: FLANGE WRENCH (498427200)

Tightening torque:

191 N·m (19.5 kgf·m, 140.9 ft·lb)



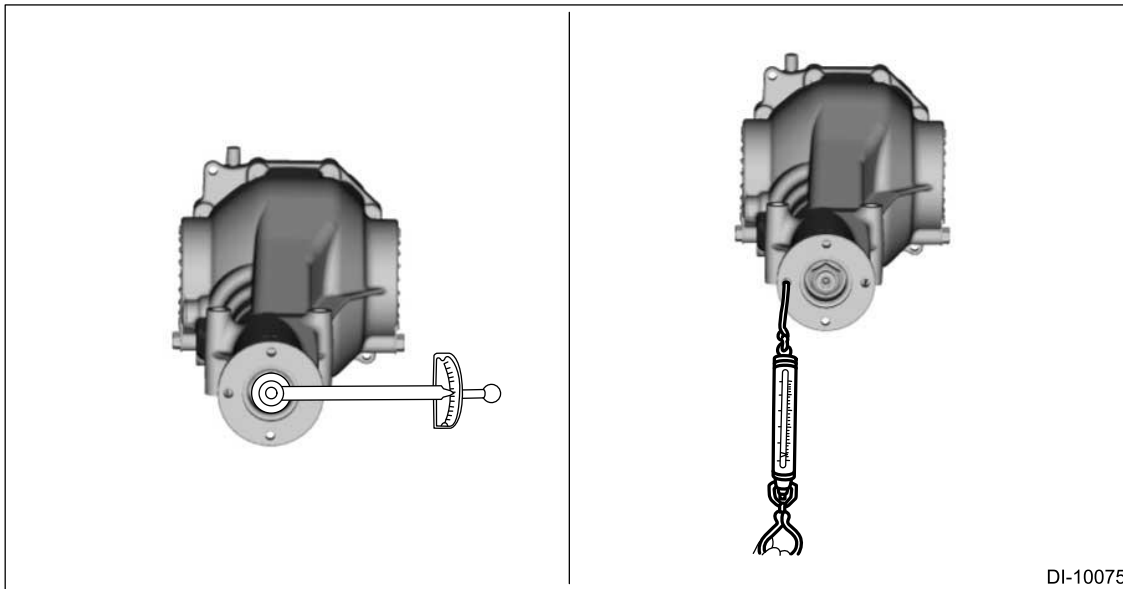
Specification:

Initial torque

0.48 — 1.22 N·m (0.05 — 0.12 kgf-m, 0.35 — 0.90 ft-lb)

Initial load

12.7 — 32.2 N (1.29 — 3.28 kgf, 2.86 — 7.24 lbf)



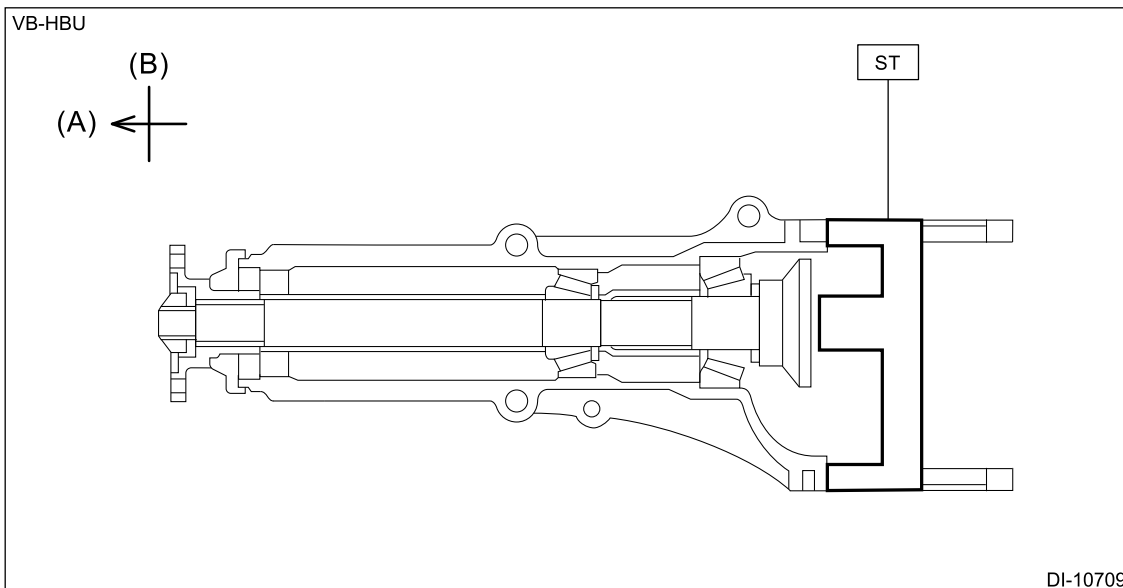
(10) Record the initial torque or initial load after preload adjustment.

2. Adjusting drive pinion height

(1) Set the ST.

Preparation tool:

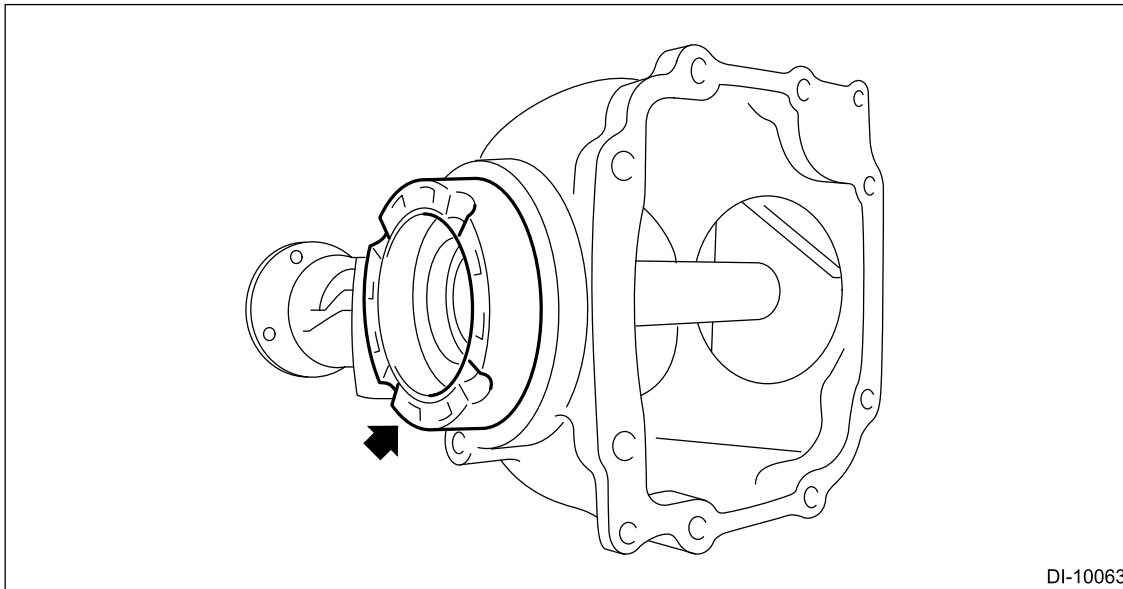
ST: DIFFERENTIAL CARRIER GAUGE (18831AA010)



(A) Front side

(B) RH side

(2) Install the differential side retainer to the left side of the differential carrier in the reverse direction.



DI-10063

(3) Measure the clearance between the ST1 and ST2 by using a thickness gauge.

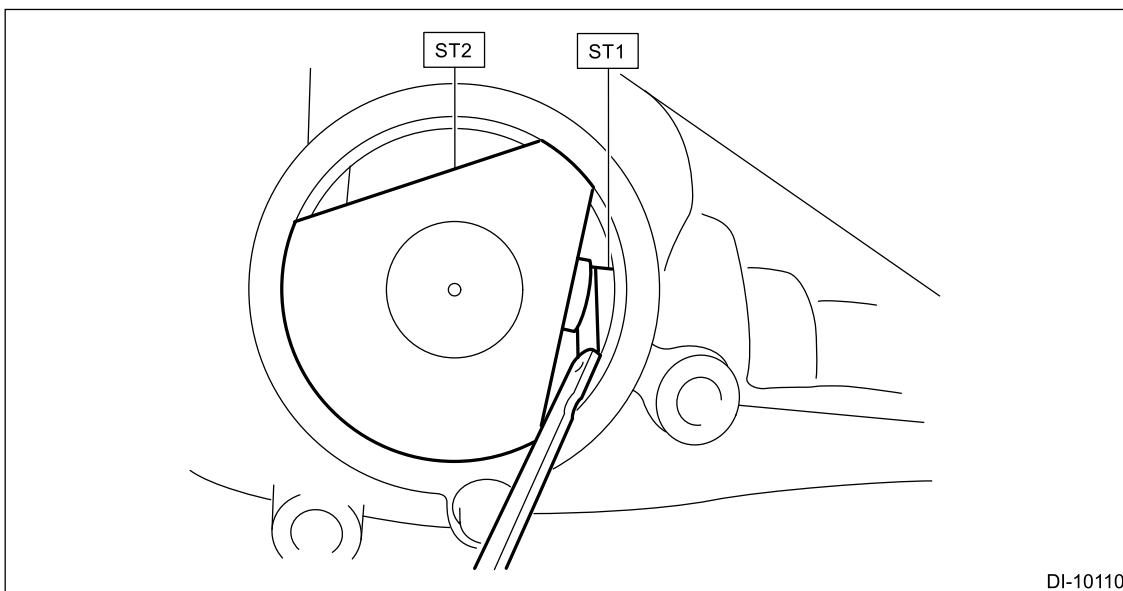
Note:

Make sure there is no clearance between the differential carrier and ST2.

Preparation tool:

ST1: DUMMY SHAFT (18678AA000)

ST2: DIFFERENTIAL CARRIER GAUGE (18831AA010)



DI-10110

(4) Select an appropriate pinion height adjusting washer using the following calculation.

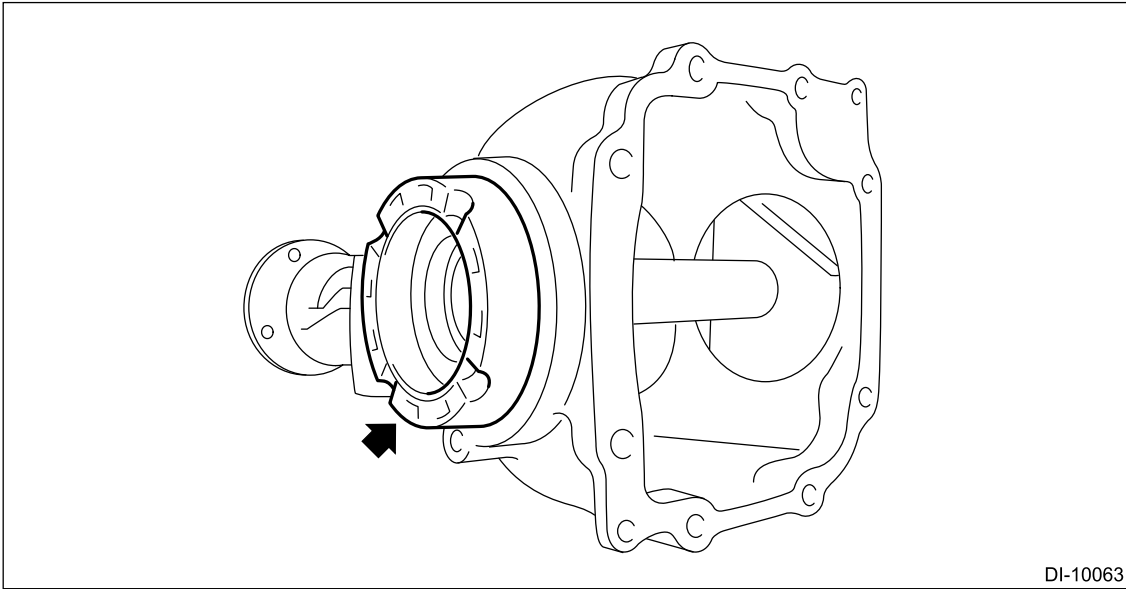
Note:

Adjust using 1 – 3 pieces.

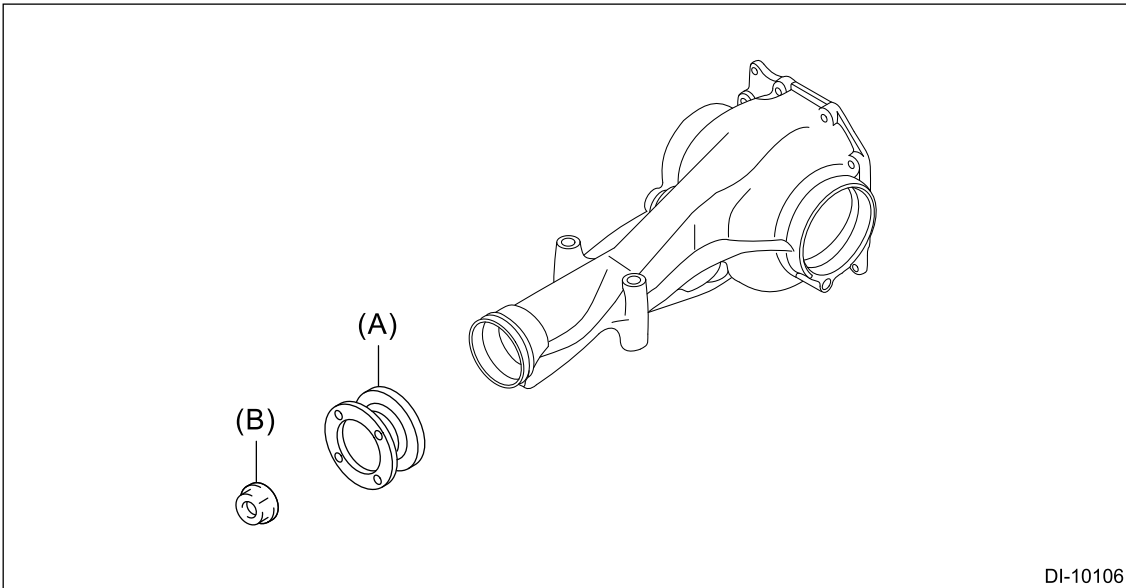
$$T = T_o + C - 0.05 \text{ mm (0.002 in)}$$

T	Thickness of pinion height adjusting washer mm (in)
T _o	Thickness of washer temporarily inserted mm (in)
C	Clearance of thickness gauge mm (in)

3. Remove the differential side retainer.



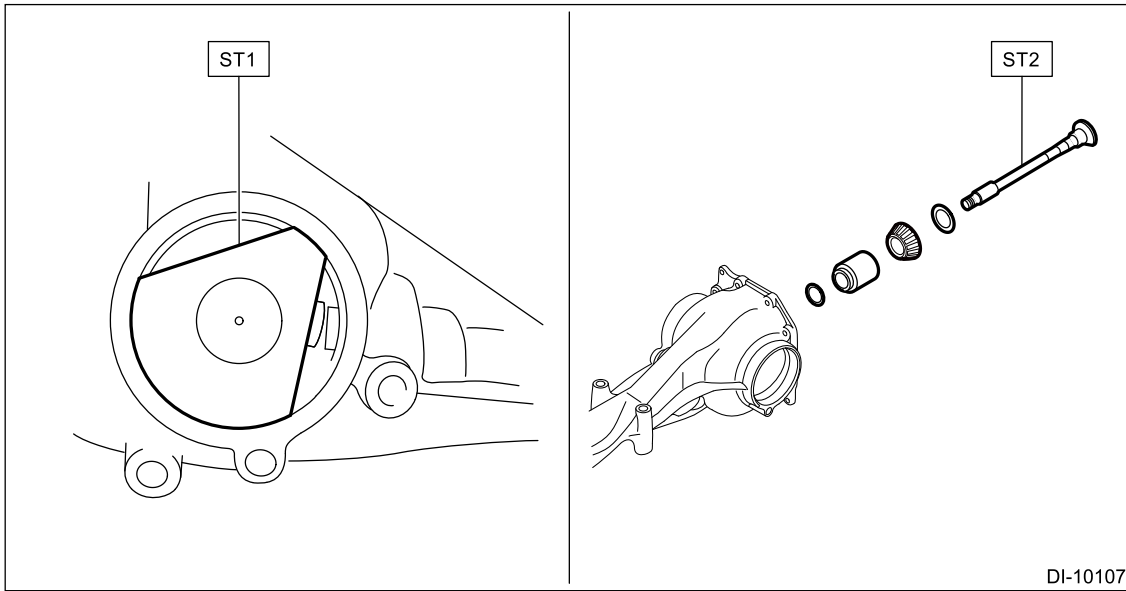
4. Remove the self-locking nut and the companion flange.



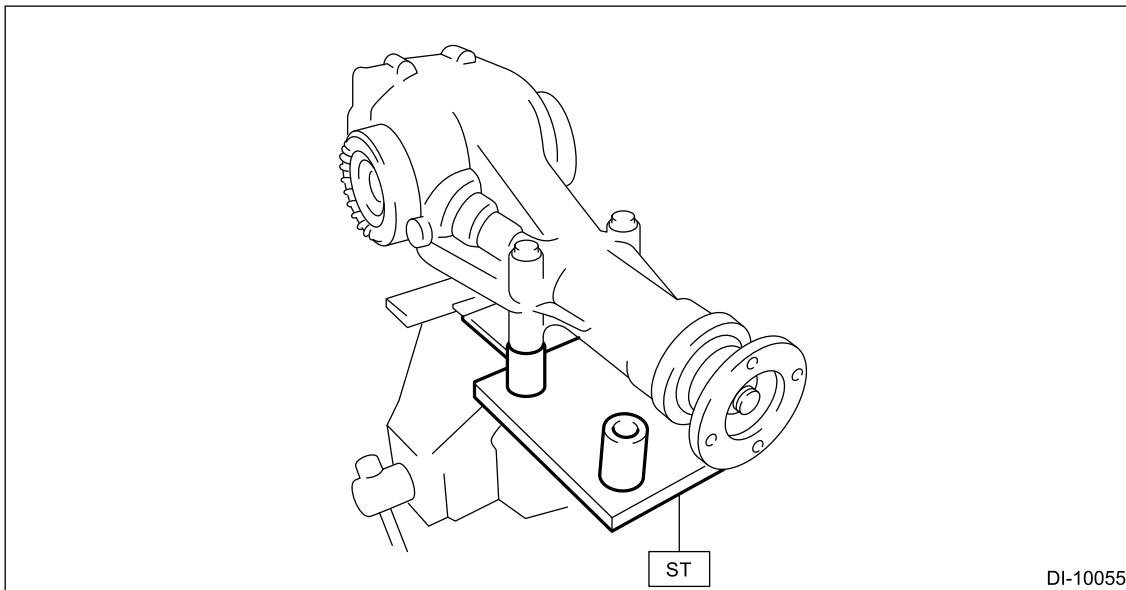
(A) Companion flange

(B) Self-locking nut

5. Remove the ST1, ST2 and each part.

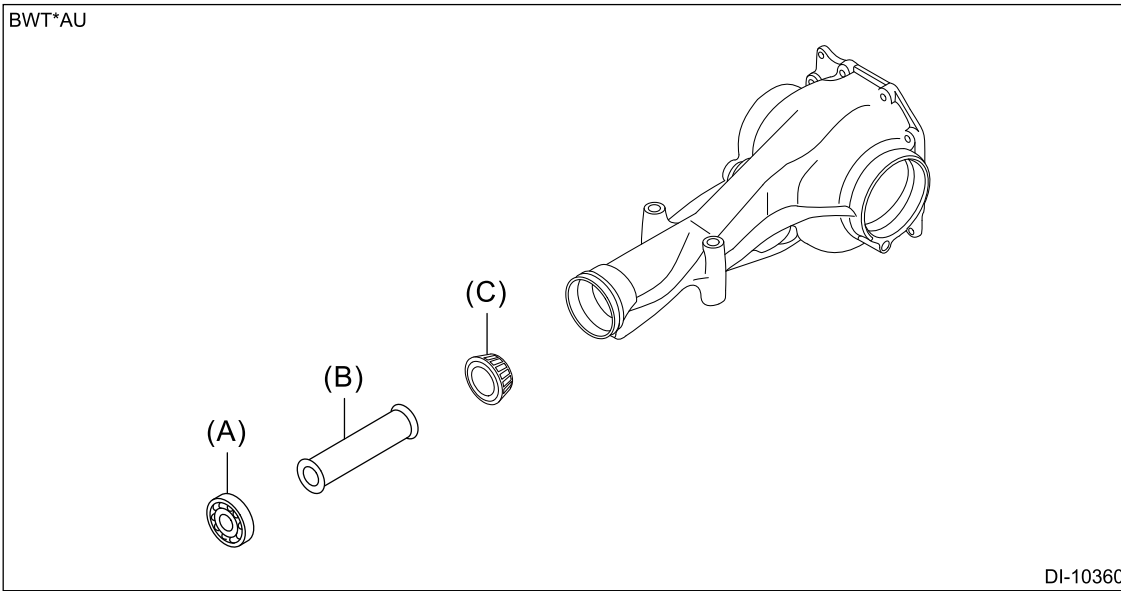


6. Remove the rear differential from ST.



7. Remove the pilot bearing, spacer and front bearing inner race.

BWT*AU



DI-10360

(A) Pilot bearing

(B) Spacer

(C) Front bearing inner race

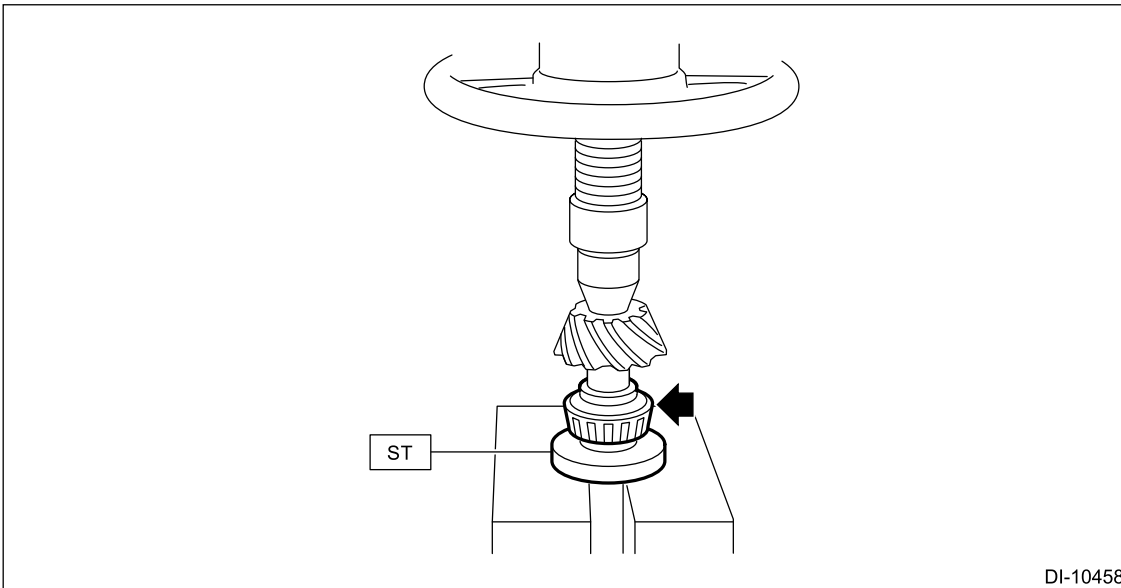
8. Set the pinion height adjusting washer to the drive pinion.
9. Press-fit the rear bearing inner race using the ST and a press.

Note:

Apply the differential gear oil to the rear bearing inner race.

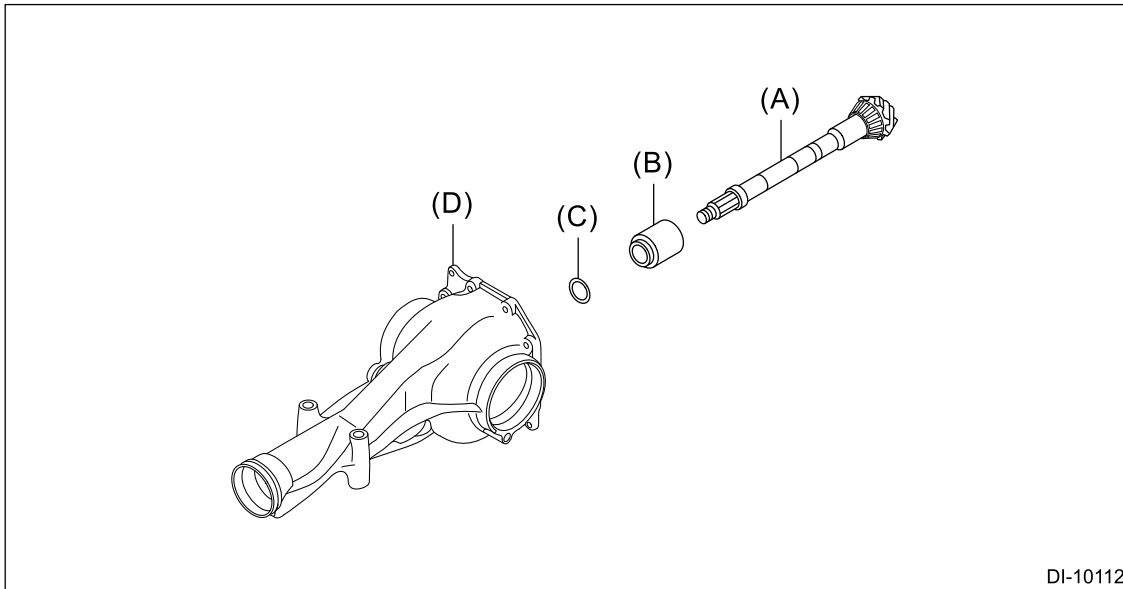
Preparation tool:

ST: INSTALLER (398177700)



DI-10458

10. Set the preload adjusting spacer and preload adjusting washer on the drive pinion, and insert them in the differential carrier.



DI-10112

- (A) Drive pinion (C) Preload adjusting washer (D) Differential carrier
 (B) Preload adjusting spacer

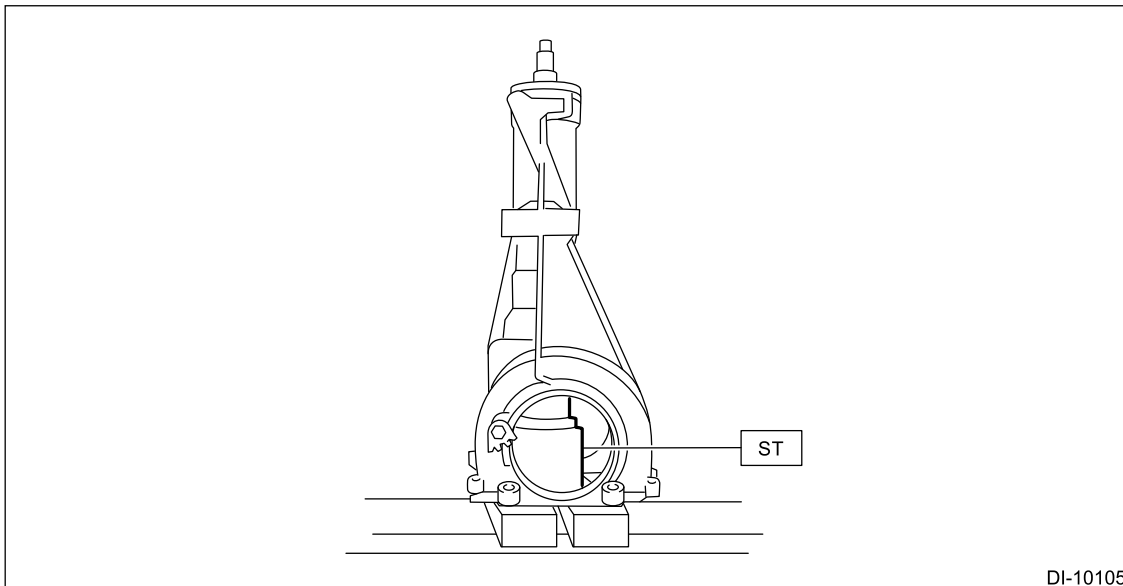
11. Set the ST and differential carrier to the press.

Note:

Leave the ST and differential carrier set on the press until the companion flange is press-fitted.

Preparation tool:

ST: WEIGHT (399780104)



DI-10105

12. Press-fit the front bearing inner race (A) using the ST, spacer (B) and press.

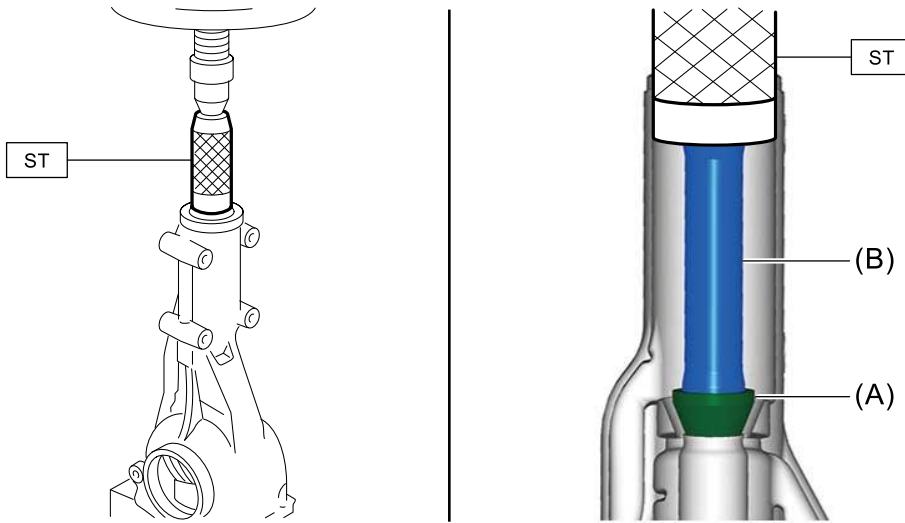
Note:

- Apply the differential gear oil to the front bearing inner race.
- Leave the spacer as being set.

Preparation tool:

ST: INSTALLER (899580100)

SK-*AE



DI-10138

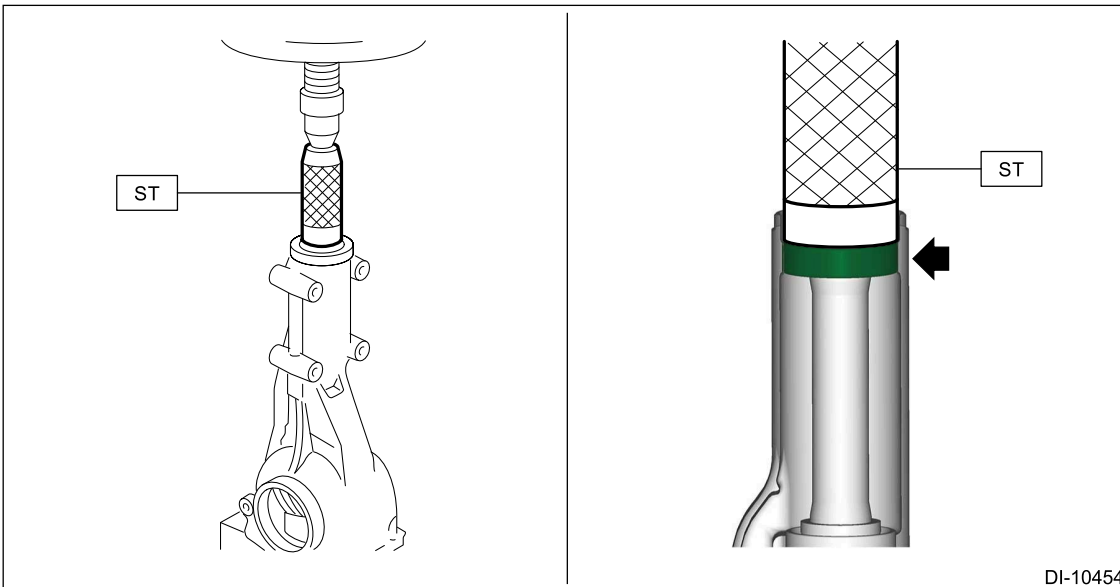
13. Press-fit a pilot bearing using the ST and a press.

Note:

Apply the differential gear oil to the pilot bearing.

Preparation tool:

ST: INSTALLER (899580100)



DI-10454

14. Press-fit a new differential front oil seal using the ST and press.

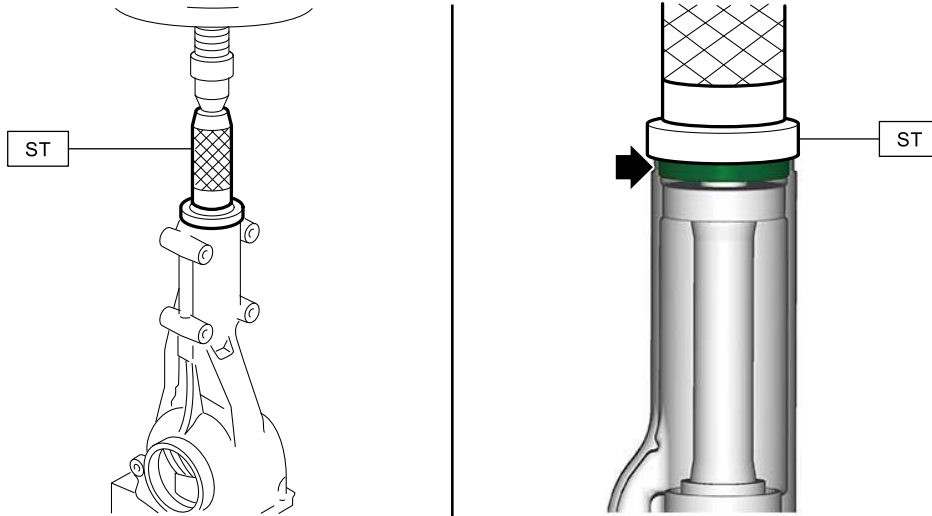
Note:

- Press-fit the differential front oil seal so that it comes 1 mm (0.04 in) inward from end of carrier.
- Apply differential gear oil to the differential front oil seal lip.

Preparation tool:

ST: INSTALLER (498447120)

BWT*AU



DI-10369

15. Press-fit the companion flange with ST and press.

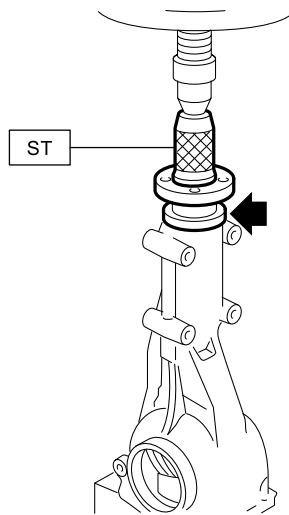
Caution:

Be careful not to damage the pilot bearing.

Preparation tool:

ST: INSTALLER (899874100)

BWT*AU

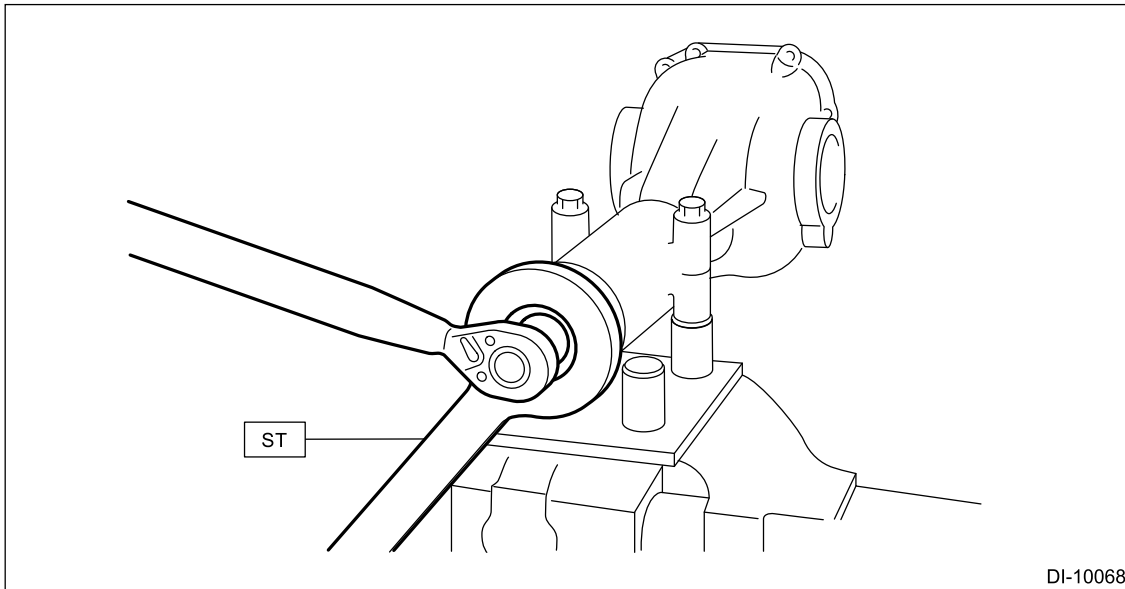


DI-10372

16. Attach the rear differential to the ST.

Preparation tool:

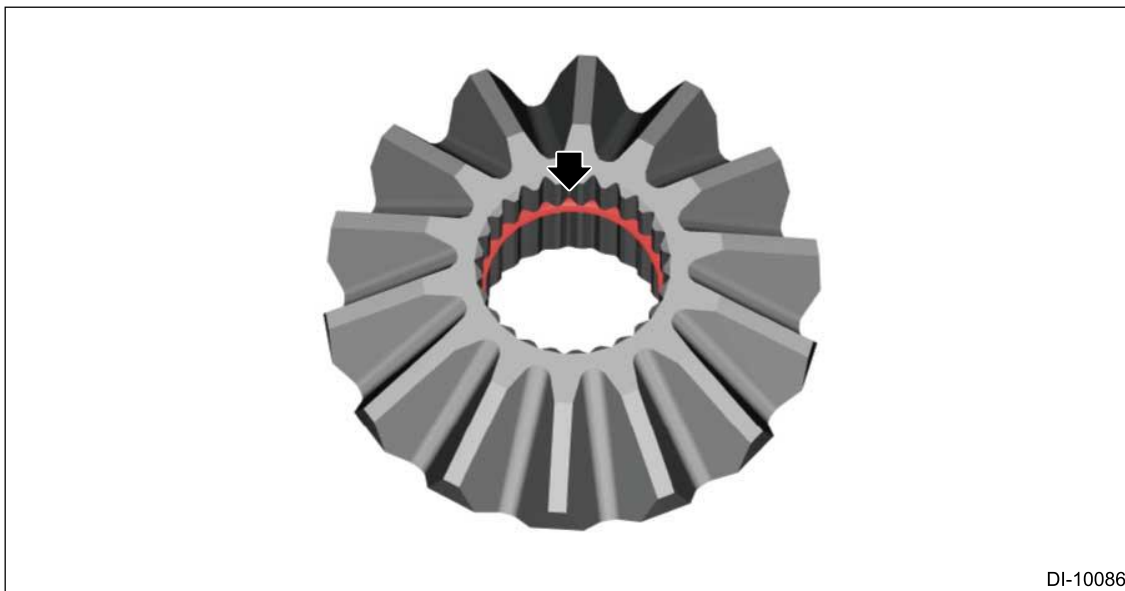
ST: ATTACHMENT SET (398217700)



DI-10068

19. Assembling differential case

(1) Install new circlips.

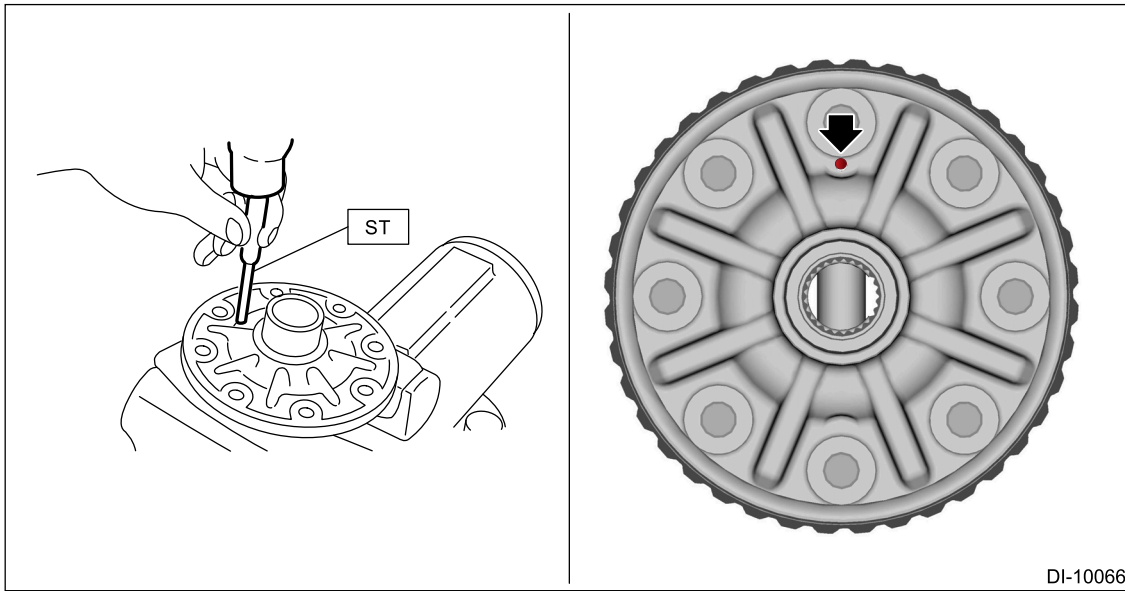


DI-10086

(2) Set the differential bevel pinion, differential bevel gear and thrust washer, and install the pinion shaft.

Note:

- Apply differential gear oil on the sliding portion of the differential bevel gear, thrust washer and pinion shaft.
- Install the thrust washer with its chamfered side facing the differential bevel gear.



DI-10066

20. Install the driven gear to the differential case.

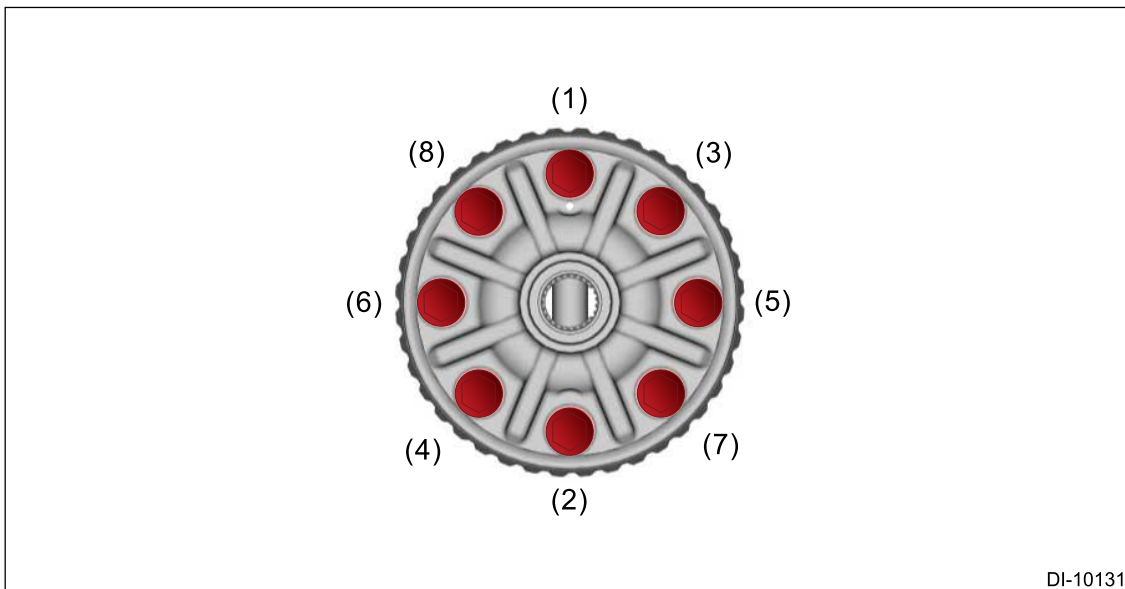
(1) Tighten the bolts in the numerical order as shown in the figure.

Note:

Make sure there is no clearance between the differential case and driven gear.

Tightening torque:

20 N·m (2.0 kgf-m, 14.8 ft-lb)

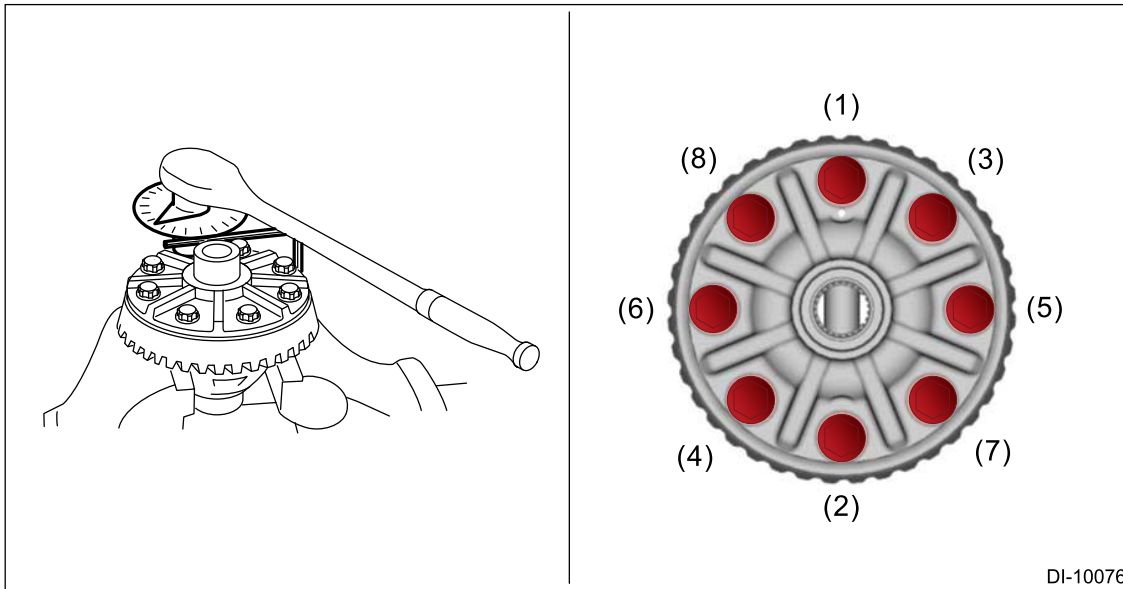


DI-10131

(2) Using an angle gauge, tighten the bolts to the specified angle in the numerical order as shown in the figure.

Tightening angle:

46°



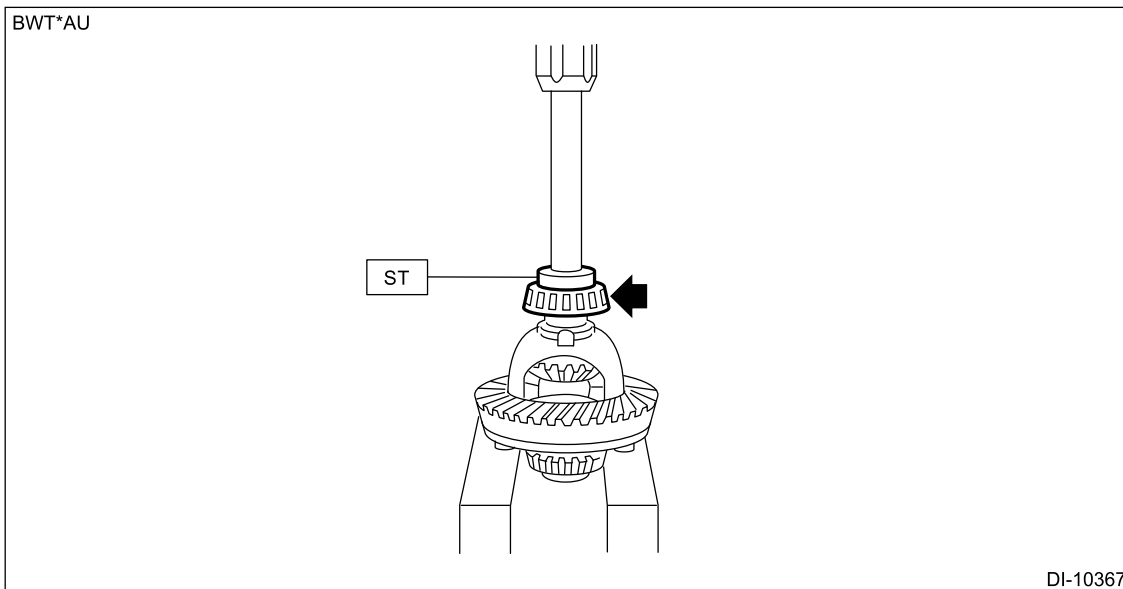
21. Press-fit a new side bearing inner race using the ST and a press.

Note:

Apply the differential gear oil to the side bearing inner race.

Preparation tool:

ST: DRIFT (398487700)



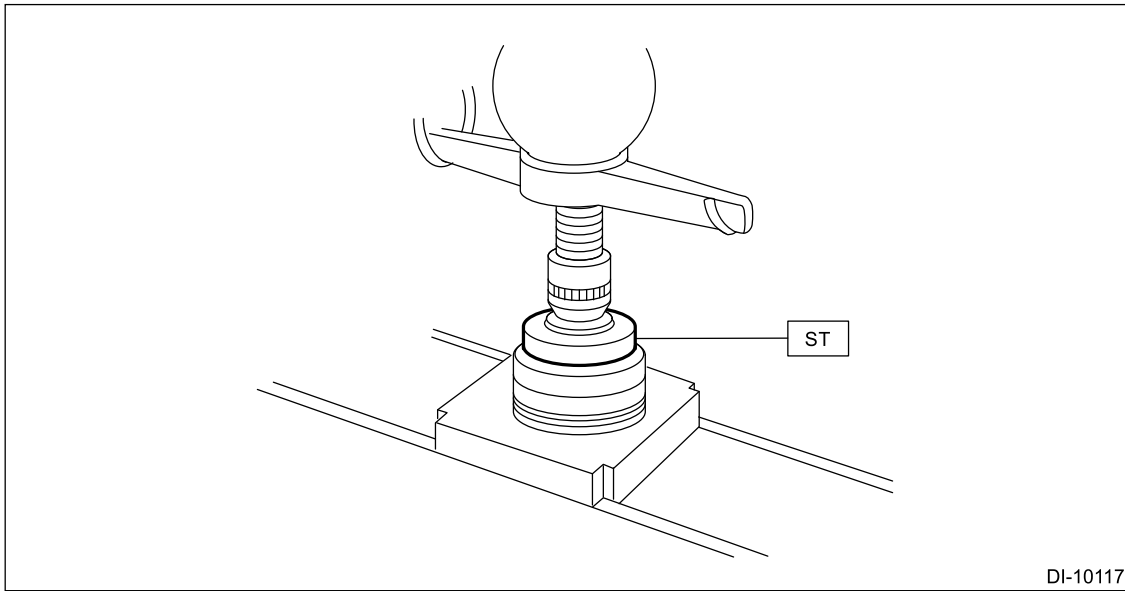
22. Press-fit a new side bearing outer race using the ST and a press.

Note:

Apply the differential gear oil to the side bearing outer race.

Preparation tool:

ST: DRIFT (398417700)

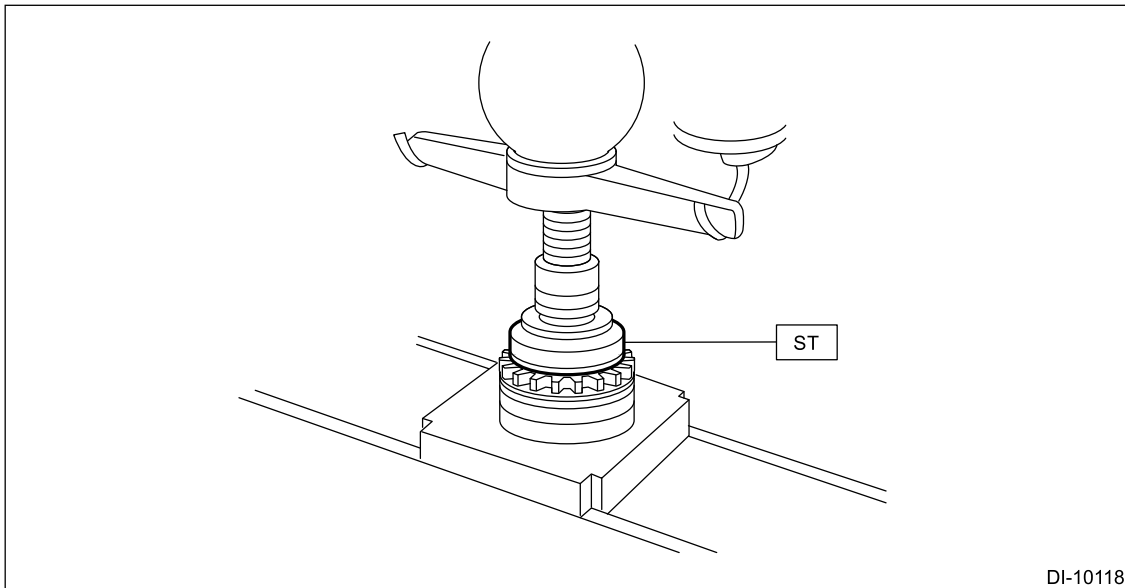


DI-10117

23. Press-fit a new differential side retainer oil seal using the ST and press.

Preparation tool:

ST: OIL SEAL INSTALLER (398437700)

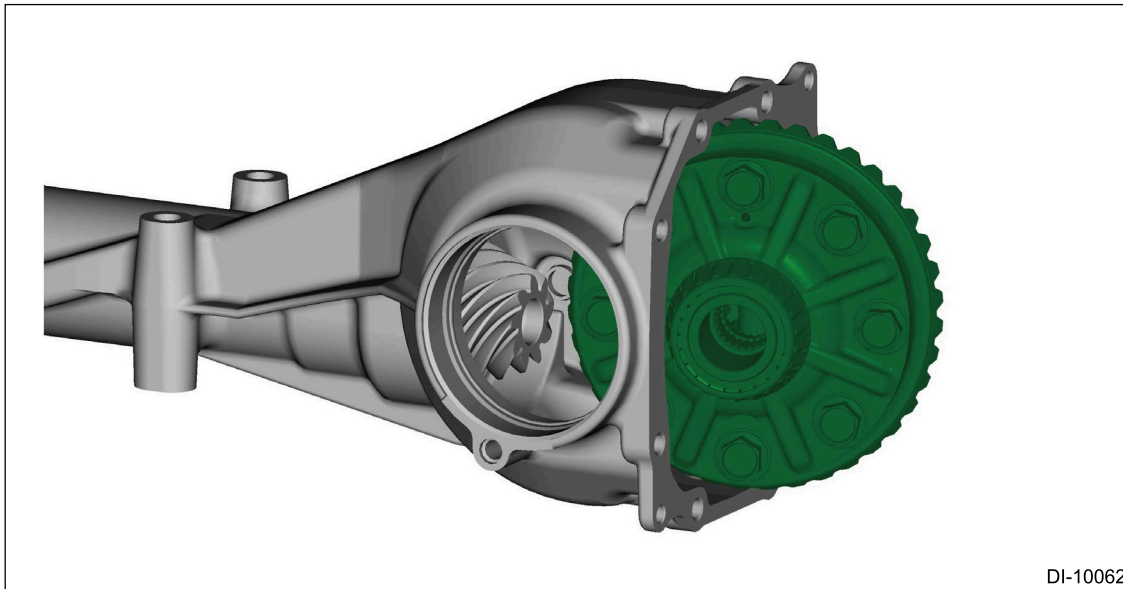


DI-10118

24. Set the differential case.

Caution:

- Be careful not to drop the differential carrier.
- Be careful not to hit the teeth of driven gear against the differential carrier.



25. Temporarily install the differential side retainer.

Caution:

- **Be careful not to drop the differential carrier.**
- **Be careful not to hit the teeth of driven gear against the differential carrier.**

Note:

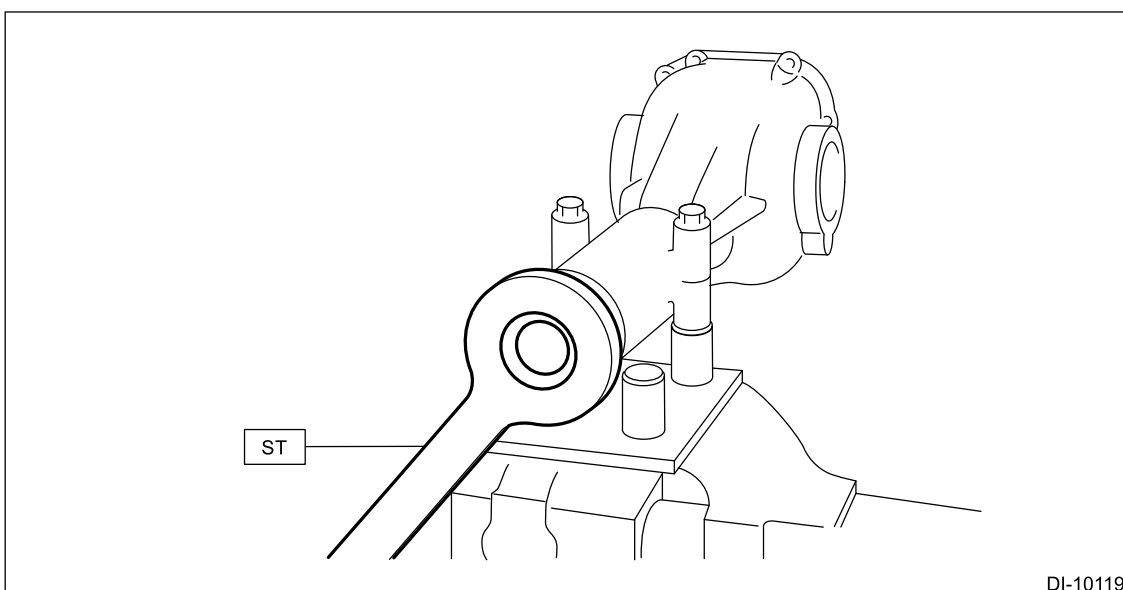
- **When the side bearing is reused, do not confuse the left and right side.**
- **Apply differential gear oil to the threads of the side bearing and the differential side retainer.**
- **Do not install the O-ring.**

26. Backlash adjustment of hypoid gear set and preload adjustment of side bearing

(1) Turn the drive pinion with the ST to seat the side bearing securely.

Preparation tool:

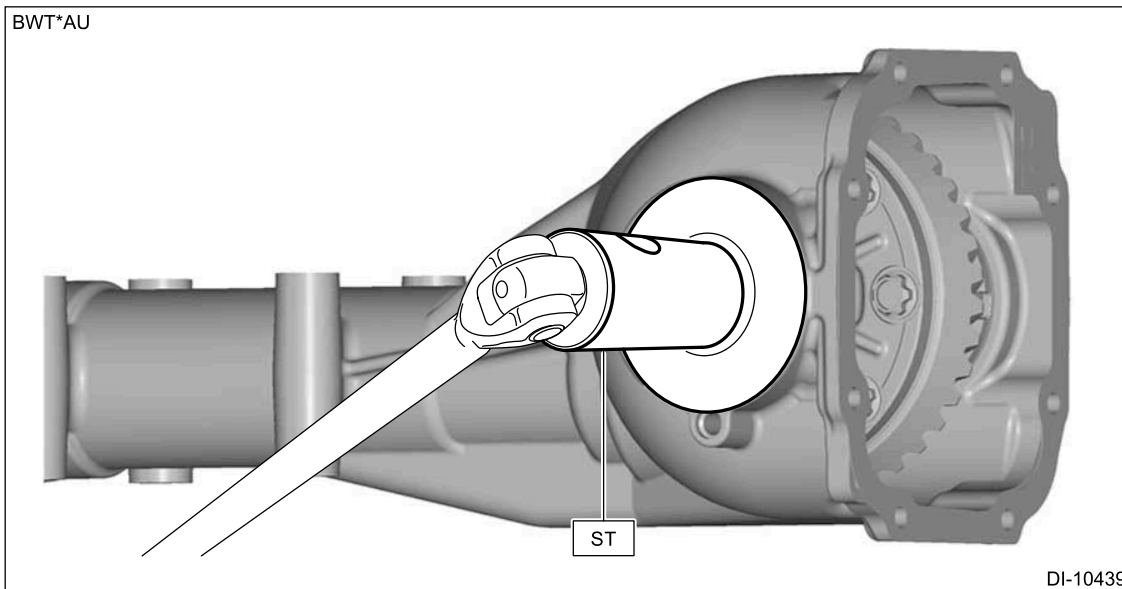
ST: FLANGE WRENCH (498427200)



(2) Using the ST, tighten differential side retainer (RH side), and then tighten differential side retainer (LH side) until there is no backlash.

Caution:
Be careful not to overtighten.

Preparation tool:
ST: WRENCH COMPL RETAINER (18658AA021)

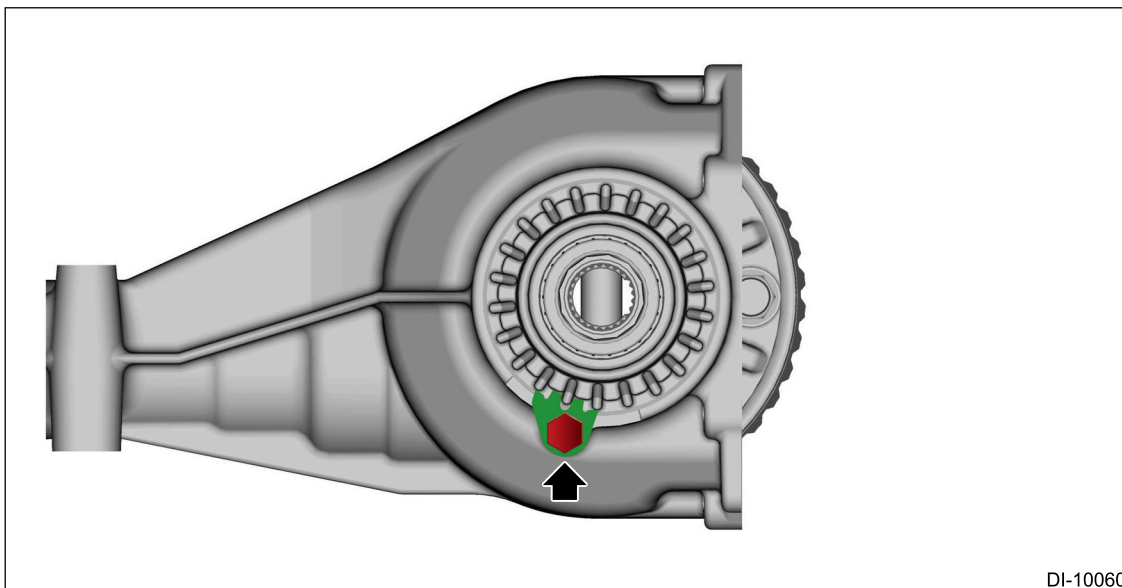


- (3) Return the differential side retainer (LH) by 1.5 notches, and tighten the differential side retainer (RH) by 2 notches.

Note:
This sets the preload.

- (4) Temporarily attach the lock plate.

Note:
Turn over the lock plate to shift by 0.5 teeth if the lock plate does not align with the teeth.



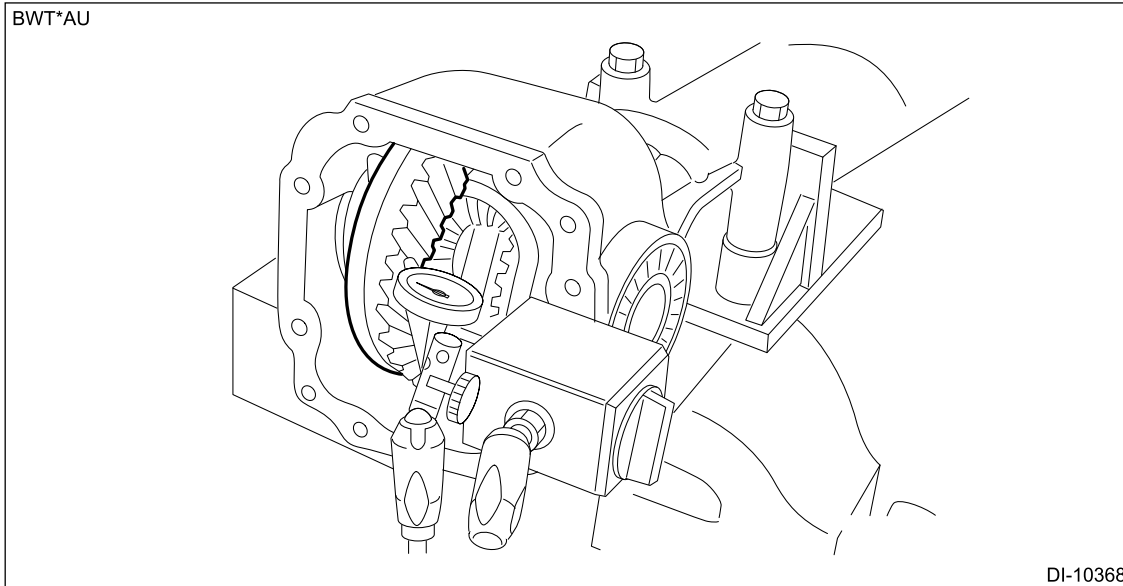
- (5) Using a magnet stand and dial gauge (spindle type), measure the backlash of hypoid gear set.

Note:

If it is outside the specification, perform the backlash adjustment of the hypoid gear set and the preload adjustment of the side bearing again.

Specification:

0.10 — 0.15 mm (0.004 — 0.006 in)



27. Checking and adjusting the tooth contact of hypoid gear set

- (1) Apply lead-free red dye evenly on the three to four teeth of the driven gear.
- (2) Rotate the driven gear back and forth several times, and check the tooth contact.

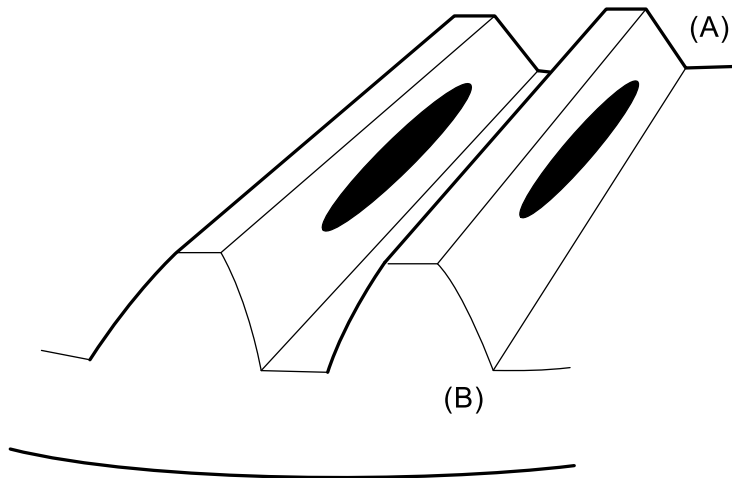
Note:

- **If proper tooth contact is not obtained, readjust the backlash of hypoid gear set and drive pinion height.**
- **Wipe off the lead-free red dye completely after the check and adjustment are completed.**

a. **Correct tooth contact**

Tooth contact pattern is slightly shifted toward toe side under no-load rotation. (When driving, it moves towards the heel side.)

BT-*A*



DI-10522

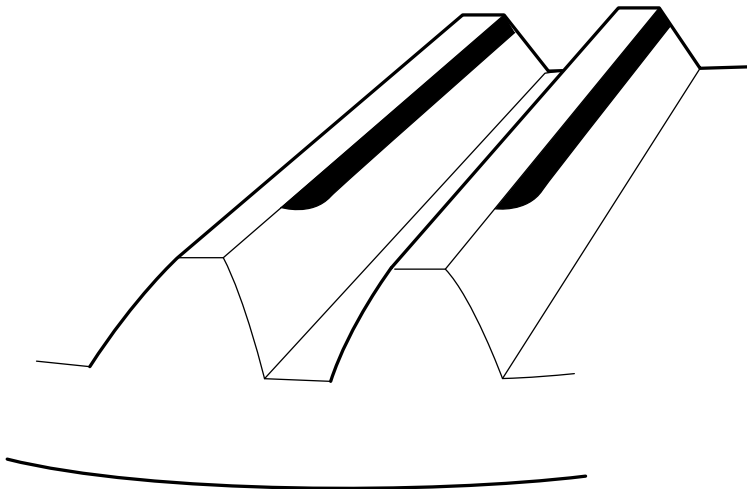
(A) Toe side (inside)

(B) Heel side (outside)

b. Face contact

Cause: Excessive backlash

BT-*A*

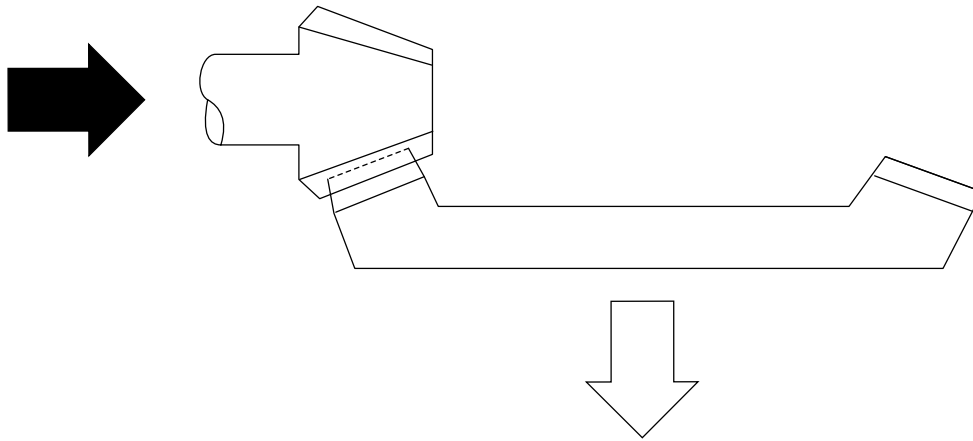


DI-10523

Adjustment: Loosen the differential side retainer (RH), and tighten the differential side retainer (LH) by the same amount.

Or, adjust the pinion height adjusting washer thickness to move the drive pinion toward the driven gear side.

BT-*A*

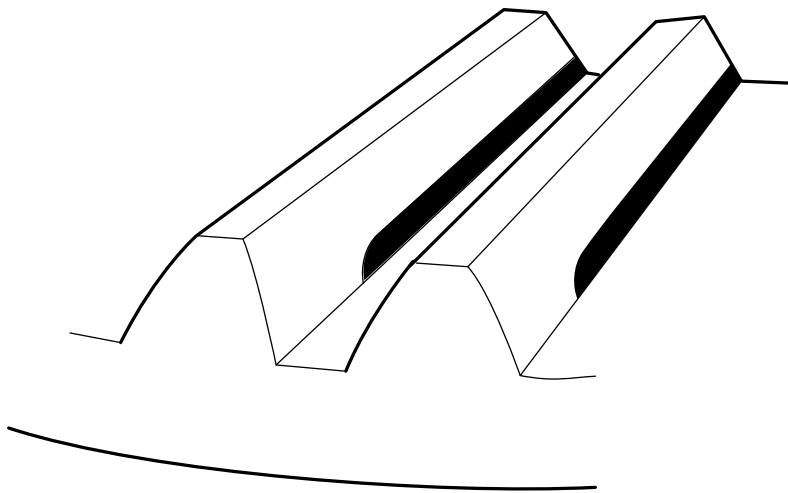


DI-10524

c. Flank contact

Cause: Too small backlash

BT-*A*

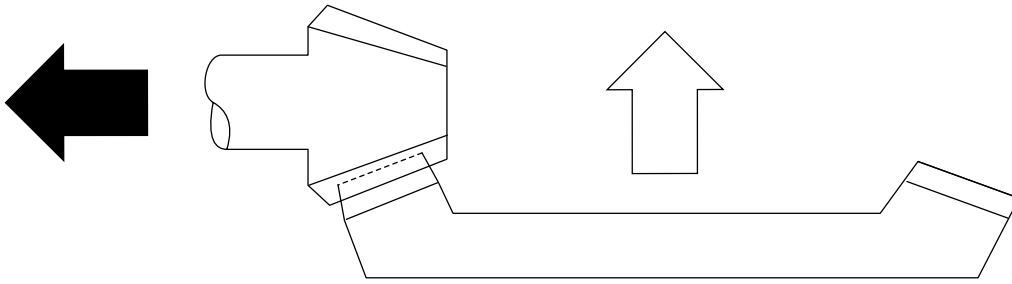


DI-10525

Adjustment: Loosen the differential side retainer (LH), and tighten the differential side retainer (RH) by the same amount.

Or, adjust the pinion height adjusting washer thickness to separate the drive pinion from the driven gear.

BT-*A*

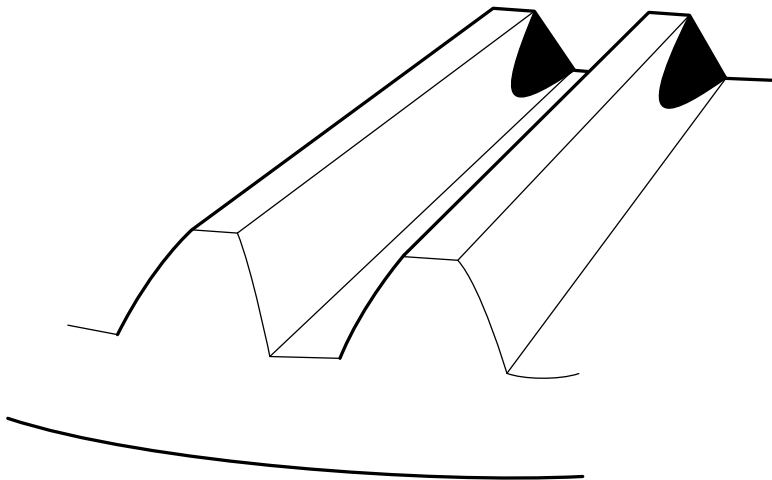


DI-10526

d. Toe contact (inside contact)

Cause: Teeth contact area is too small.

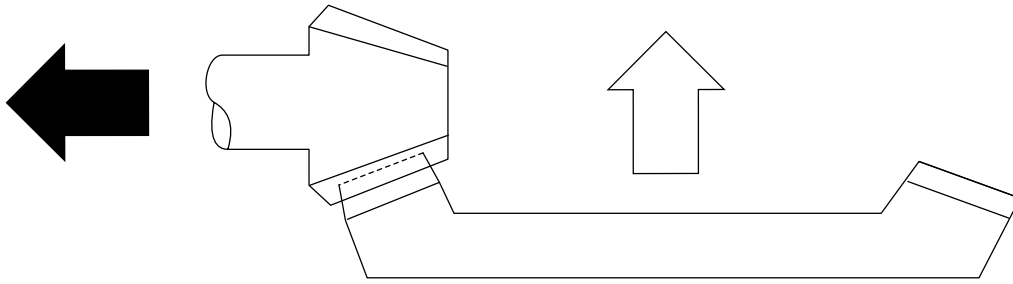
BT-*A*



DI-10527

Adjustment: Adjust the pinion height adjusting washer thickness and separate the drive pinion from the driven gear.

BT-*A*

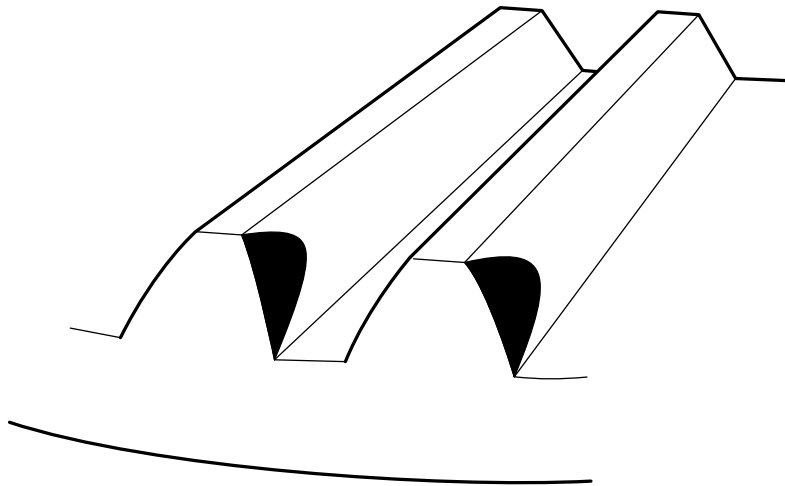


DI-10526

e. Heel contact (outside end contact)

Cause: Teeth contact area is too small.

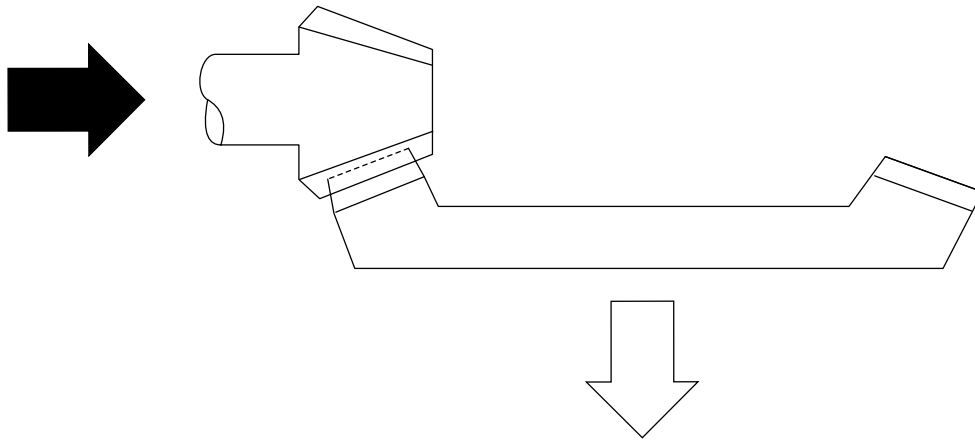
BT-*A*



DI-10528

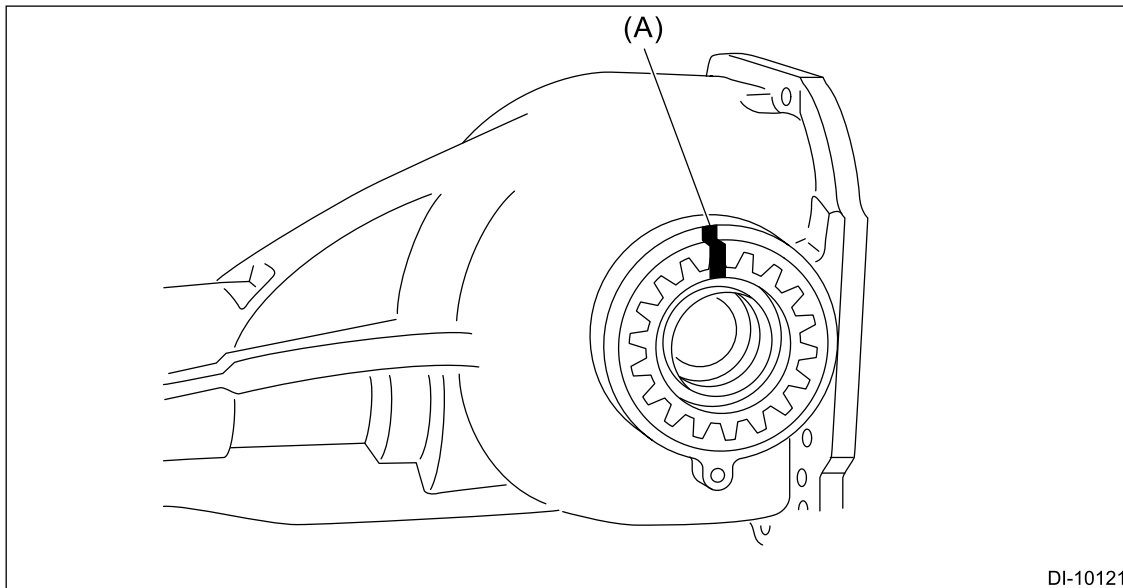
Adjustment: Adjust the pinion height adjusting washer thickness and move the drive pinion to the driven gear side.

BT-*A*



DI-10524

28. Put alignment marks (A) on the differential carrier and the differential side retainer.

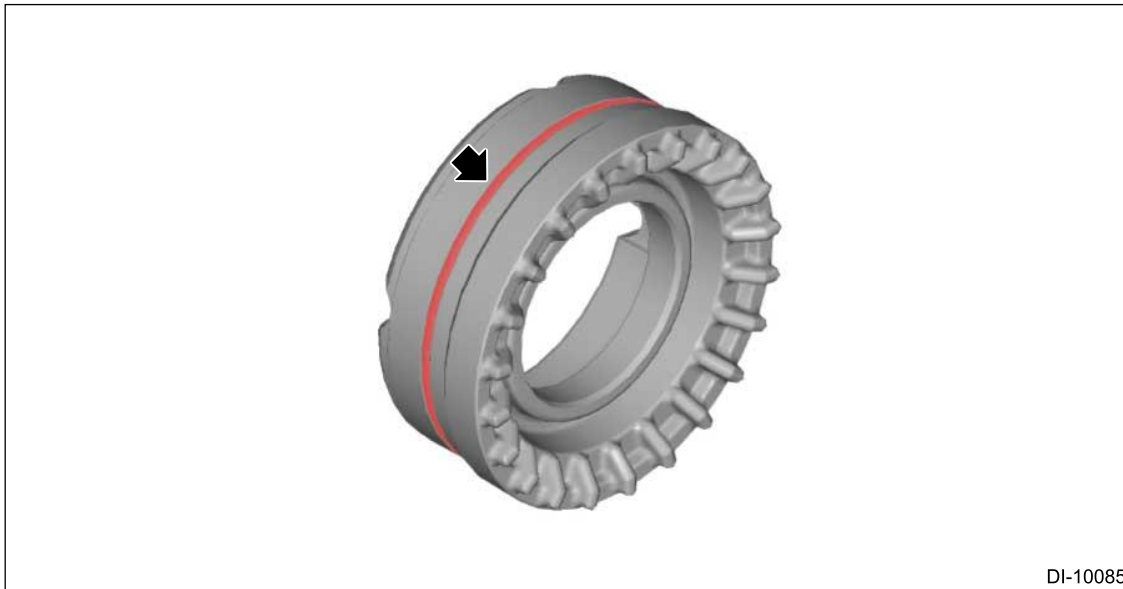


DI-10121

29. Remove the differential side retainers one by one and install new O-rings.

Note:

Apply differential gear oil to the threads of the side bearing and the differential side retainer, and to the O-ring.

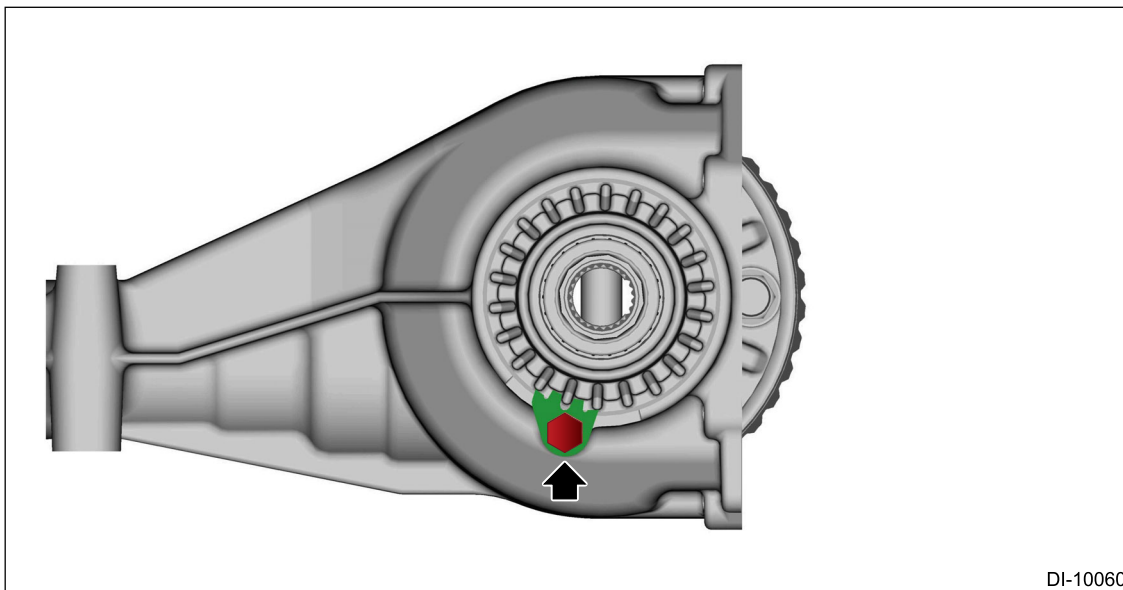


DI-10085

30. Return the differential side retainer to the original tightening position and install the lock plate.

Tightening torque:

25 N·m (2.5 kgf-m, 18.4 ft-lb)



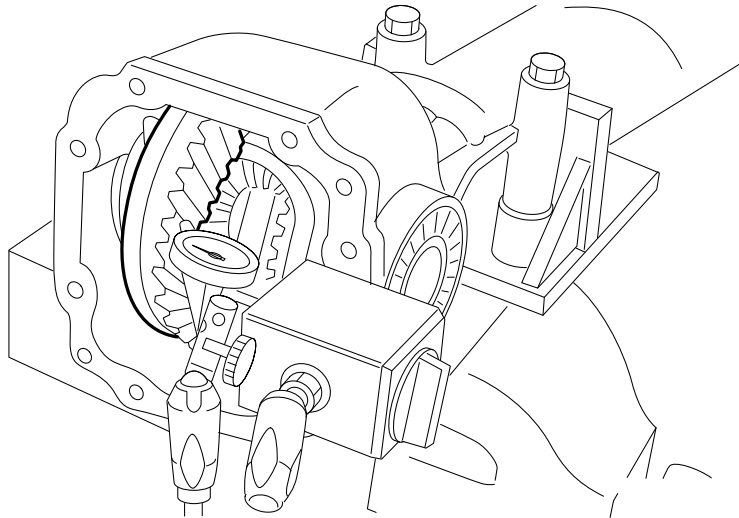
DI-10060

31. Using a magnet stand and dial gauge (spindle type), recheck the backlash of hypoid gear set.

Specification:

0.10 — 0.15 mm (0.004 — 0.006 in)

BWT*AU



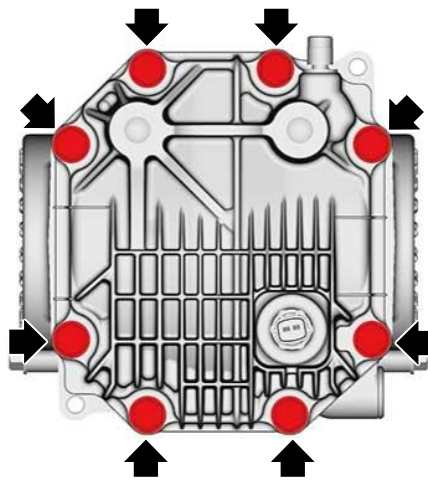
DI-10368

32. Using a new gasket, install the rear cover.

Tightening torque:

34 N·m (3.5 kgf-m, 25.1 ft-lb)

SK-*BE



DI-10442

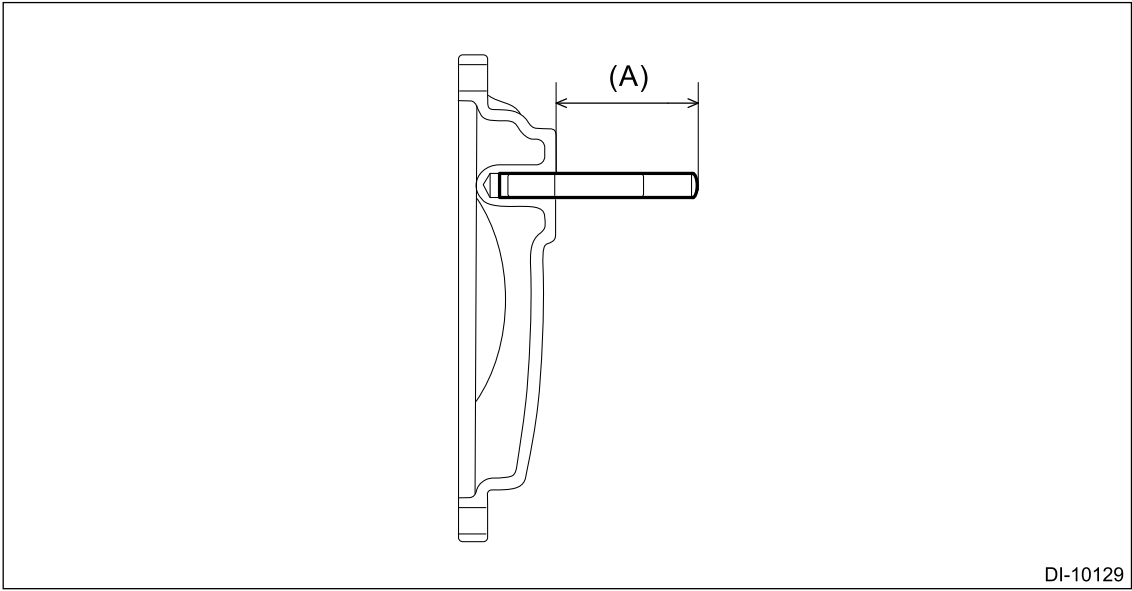
33. Install the stud bolt so that the protruding portion (A) becomes within the standard.

Caution:

Do not tighten with a tightening torque of 55 N·m (5.6 kgf-m, 40.6 ft-lb) (reference value) or more.

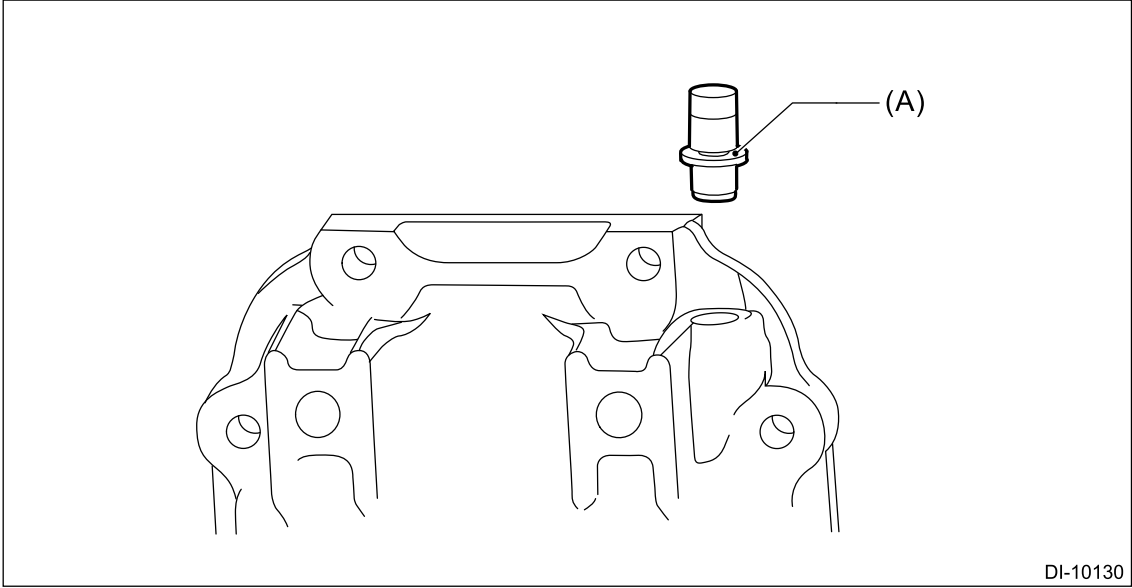
Specification:

59.0 — 61.0 mm (2.32 — 2.40 in)



DI-10129

34. Install the air breather cap by tapping the section (A).





DI-10130

DIFFERENTIALS > Rear Differential (VB-type)

INSPECTION

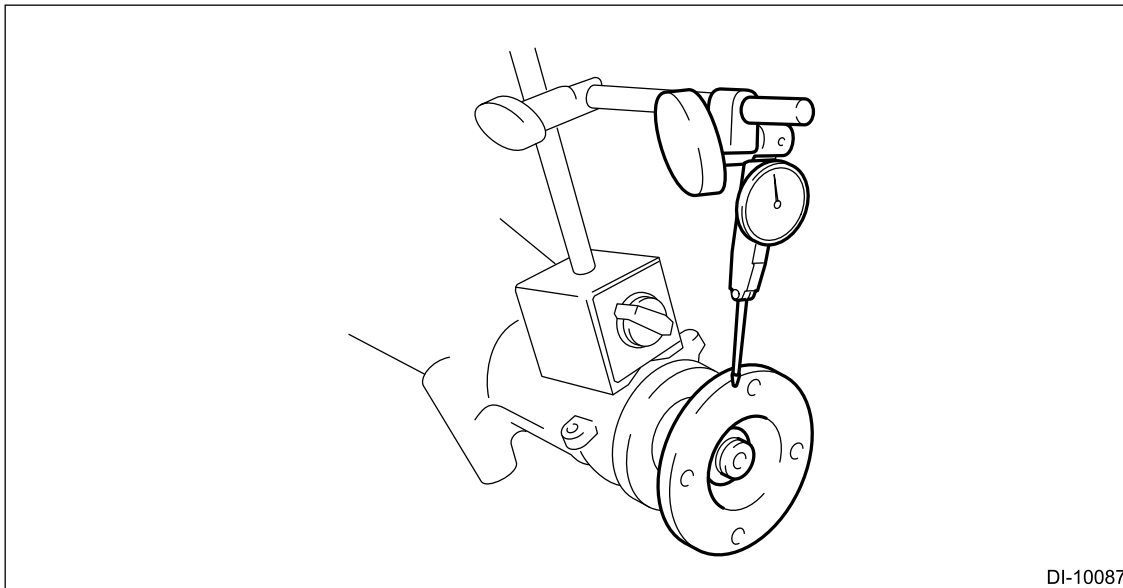
Note:

- For backlash between the differential bevel gear and differential bevel pinion, refer to "ASSEMBLY".  [Ref. to DIFFERENTIALS>Rear Differential \(VB-type\)>ASSEMBLY.](#)
- For backlash and tooth contact of hypoid gear set, refer to "ASSEMBLY".  [Ref. to DIFFERENTIALS>Rear Differential \(VB-type\)>ASSEMBLY.](#)

1. Check for oil leaks.
2. Check that there is no deformation, cracks or other damages.
3. Check each part for excessive wear.
4. Check the differential carrier and companion flange for excessive rust.
5. Check the companion flange runout.
 - (1) Remove the foreign matter and rust completely from the companion flange.
 - (2) Measure the runout of the companion flange mating surface using a magnet stand and dial gauge (lever type).

Service limit:

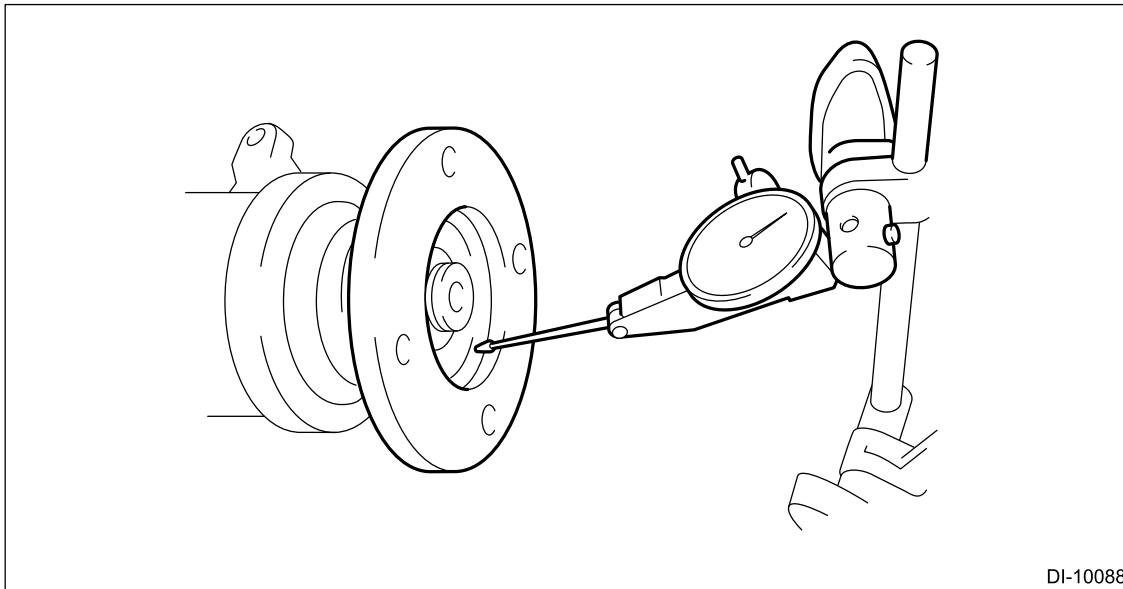
0.08 mm (0.003 in)



- (3) Measure the runout inside the companion flange using a magnet stand and dial gauge (lever type).

Service limit:

0.08 mm (0.003 in)






(4) If either runout exceeds the limit, move the phase of companion flange and drive pinion by 90° each, and find the point where the runout is within the limit.

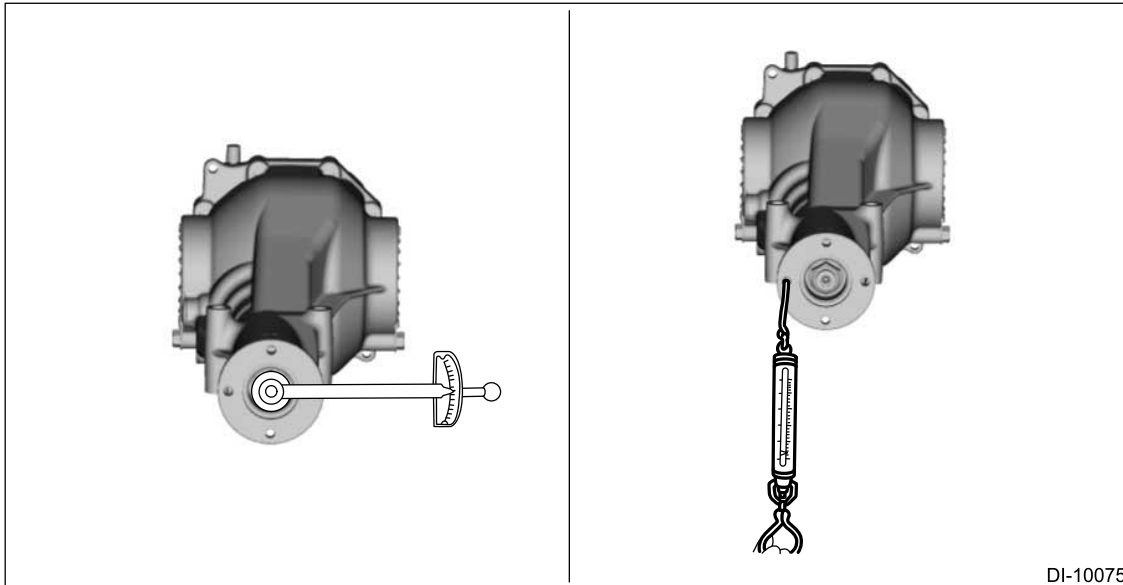
Note:

- **If the runout exceeds the limit after changing the phase, replace the companion flange and recheck the runout.**
- **If the runout exceeds the limit after replacing the companion flange, the drive pinion or bearing may be defective.**

DIFFERENTIALS > Differential Front Oil Seal

REPLACEMENT

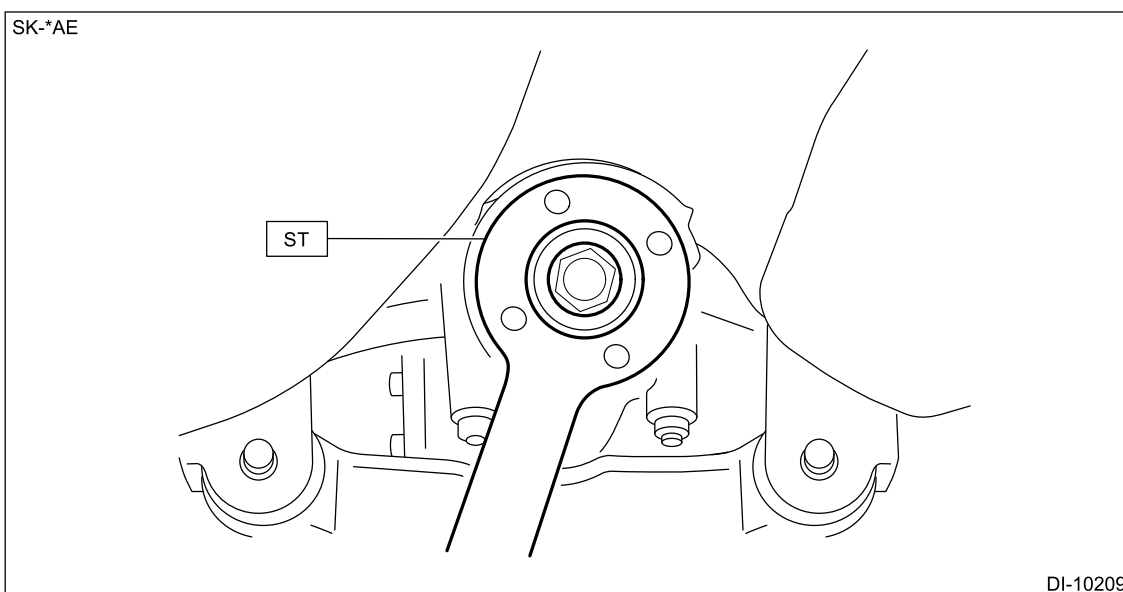
1. Release the parking brake.
2. Release the shift lock and shift the select lever to the "N range". (CVT model)  [Ref. to CONTROL SYSTEMS>Select Lever>REMOVAL.](#)
3. Drain differential gear oil.  [Ref. to DIFFERENTIALS>Differential Gear Oil>REPLACEMENT.](#)
4. Remove the propeller shaft.  [Ref. to PROPELLER SHAFT / DRIVE SHAFT / AXLE>Propeller Shaft>REMOVAL.](#)
5. Measure and record the initial torque or initial load before removing the companion flange.



6. Remove the self-locking nut while securing the companion flange with ST.

Preparation tool:

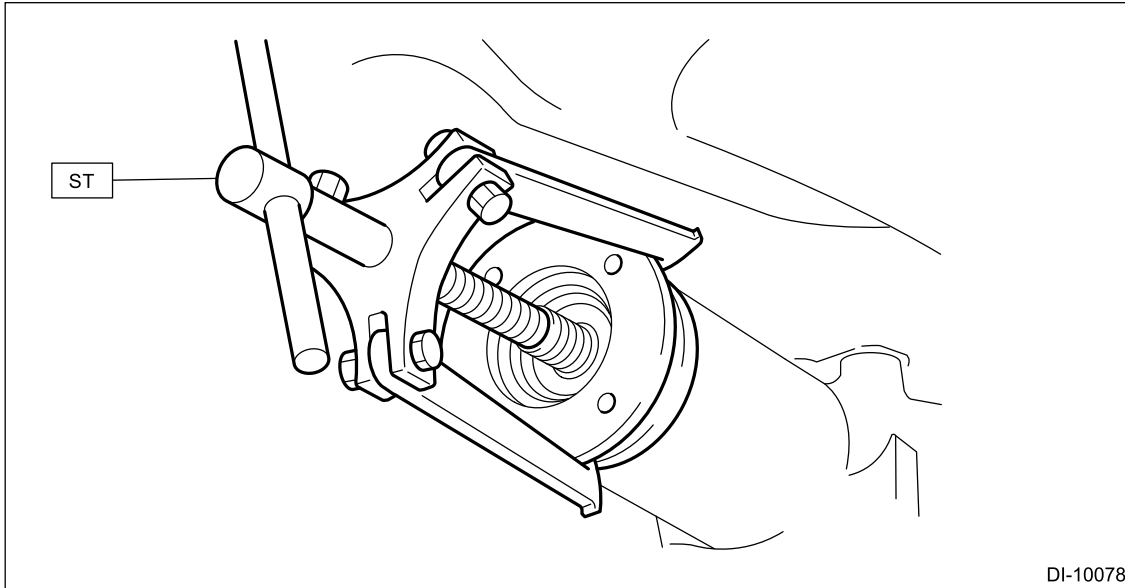
ST: FLANGE WRENCH (498427200)



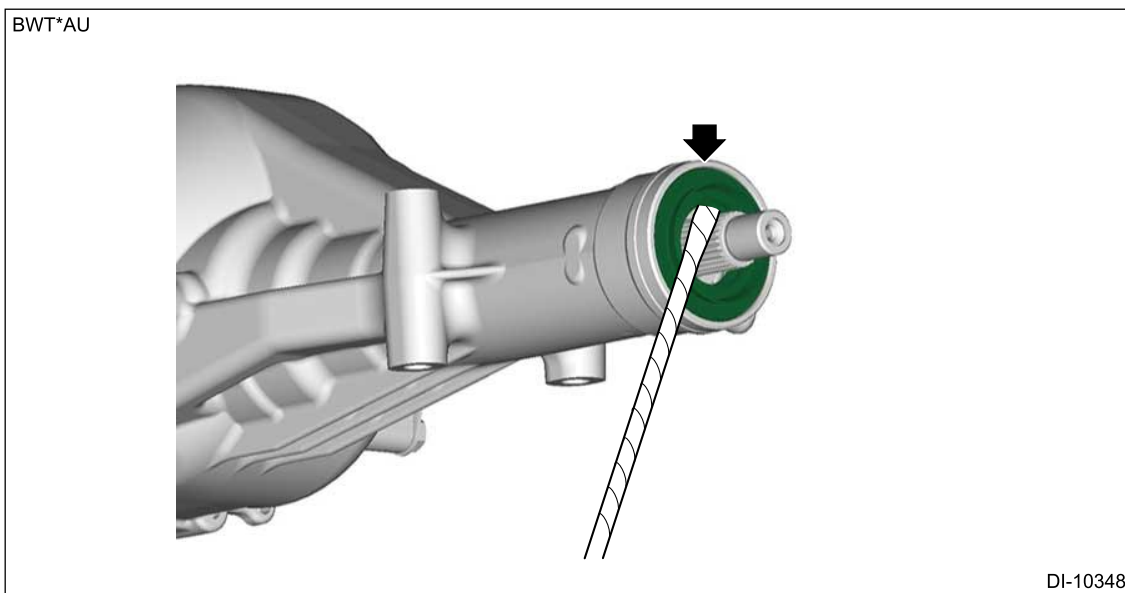
7. Extract the companion flange using the ST.

Preparation tool:

ST: PULLER ASSY (399703600)



8. Remove the differential front oil seal using a flat tip screwdriver wrapped with protection tape, etc.



9. Remove seal material from the thread portions of the companion flange and drive pinion.

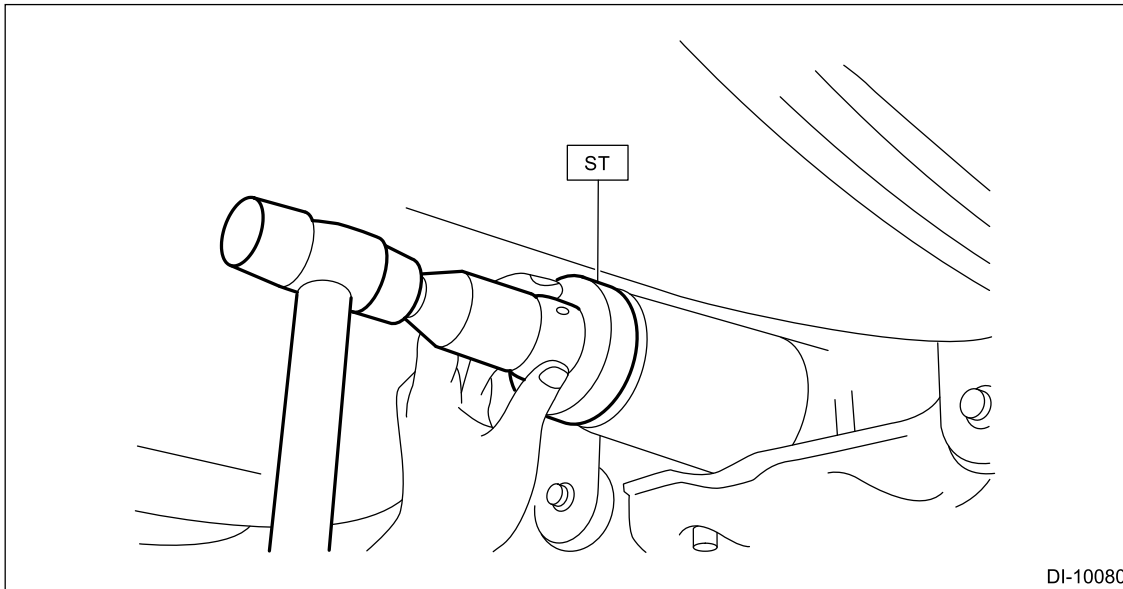
10. Install the new differential front oil seal using the ST.

Note:

- Press-fit the differential front oil seal so that it comes 1 mm (0.04 in) inward from end of the differential carrier.
- After installation, apply differential gear oil to the differential front oil seal lip.

Preparation tool:

ST: INSTALLER (498447120)



- 11.** Use a plastic hammer, etc. to install companion flange.
- 12.** Apply seal material to the drive pinion threads and the self-locking nut seat surface.

Caution:

Be sure to use a new self-locking nut.

Note:

Before applying the seal material, decrease the contact surfaces of the self locking nut and companion flange and the thread portions of the drive pinion.

Preparation items:

Seal material: THREE BOND 1324 (part No. 004403042) or equivalent

- 13.** Install the self-locking nut while securing the companion flange with the ST.

Caution:

Tighten it while adjusting within the specified torque so that the companion flange initial torque or initial load becomes the same value as that was recorded in step 5.

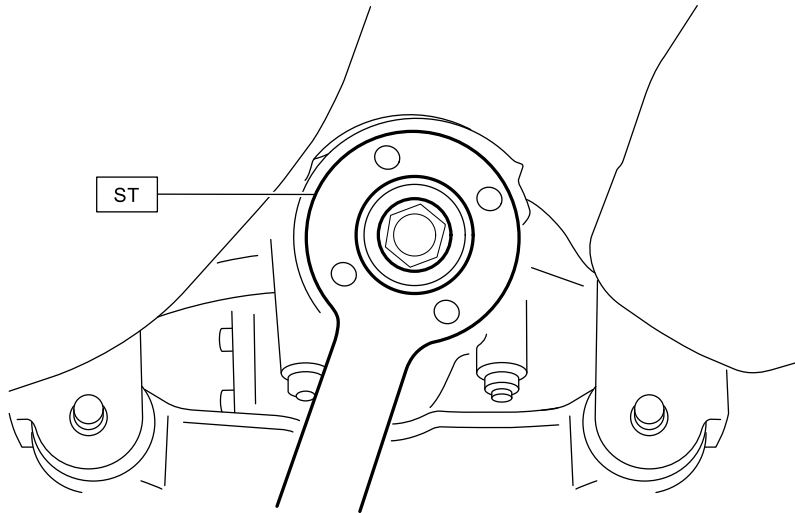
Preparation tool:

ST: FLANGE WRENCH (498427200)




Tightening torque:

162 – 220 N·m (16.5 – 22.4 kgf-m, 119.5 – 162.3 ft-lb)

SK*AE



DI-10209

- 14.** Install the propeller shaft.  [Ref. to PROPELLER SHAFT / DRIVE SHAFT / AXLE>Propeller Shaft>INSTALLATION.](#)
- 15.** Fill differential gear oil.  [Ref. to DIFFERENTIALS>Differential Gear Oil>REPLACEMENT.](#)
- 16.** Release the shift lock and shift the select lever to the "P range". (CVT model)  [Ref. to CONTROL SYSTEMS>Select Lever>INSTALLATION.](#)
- 17.** Apply the parking brake.




DIFFERENTIALS > Differential Front Oil Seal

INSPECTION

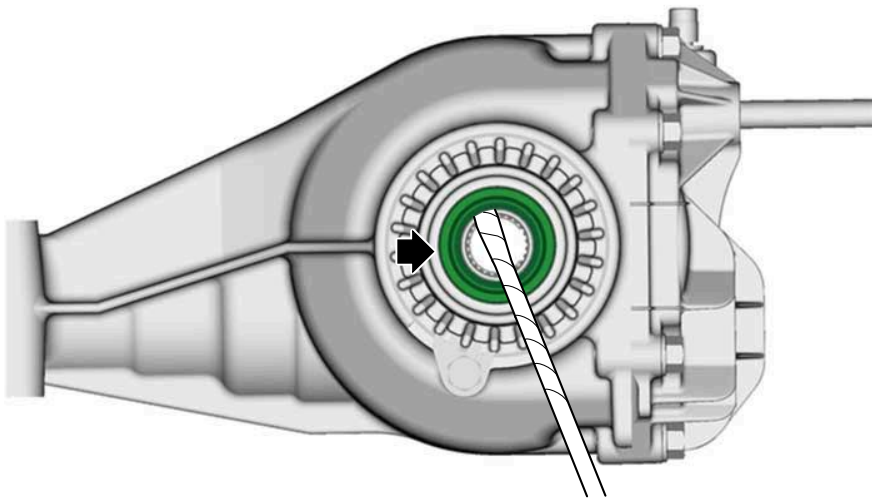
- 1.** Check for oil leaks.
- 2.** Check that there is no deformation, cracks or other damages.

DIFFERENTIALS > Differential Side Retainer Oil Seal

REPLACEMENT

- 1.** Release the parking brake.
- 2.** Release the shift lock and shift the select lever to the "N range". (CVT model)  [Ref. to CONTROL SYSTEMS>Select Lever>REMOVAL.](#)
- 3.** Drain differential gear oil.  [Ref. to DIFFERENTIALS>Differential Gear Oil>REPLACEMENT.](#)
- 4.** Remove the rear differential.  [Ref. to DIFFERENTIALS>Rear Differential \(VB-type\)>REMOVAL.](#)
- 5.** Remove the differential side retainer oil seal using a flat tip screwdriver wrapped with protection tape, etc.

BWT*AU



DI-10352

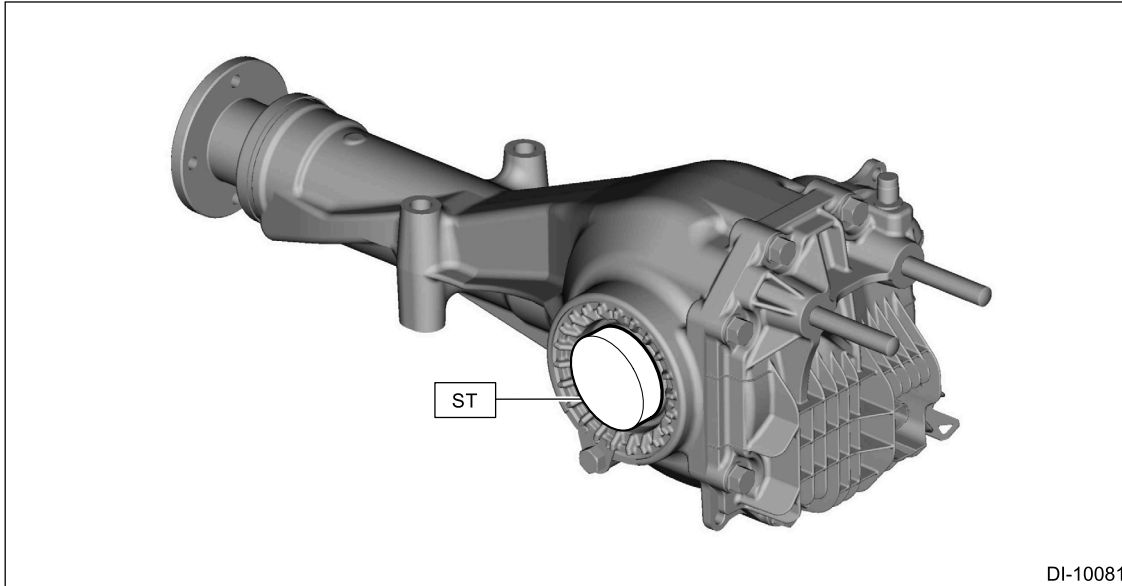
6. Install the new differential side retainer oil seal using the ST.




Note:

Since the differential side retainer oil seal has an identification mark (R or L), be careful not to mix up the RH and LH when installing.

Preparation tool:

ST: OIL SEAL INSTALLER (398437700)



7. Install the rear differential.  [Ref. to DIFFERENTIALS>Rear Differential \(VB-type\)>INSTALLATION.](#)
8. Fill differential gear oil.  [Ref. to DIFFERENTIALS>Differential Gear Oil>REPLACEMENT.](#)
9. Release the shift lock and shift the select lever to the "P range". (CVT model)  [Ref. to CONTROL SYSTEMS>Select Lever>INSTALLATION.](#)
10. Apply the parking brake.

DIFFERENTIALS > Differential Side Retainer Oil Seal

INSPECTION

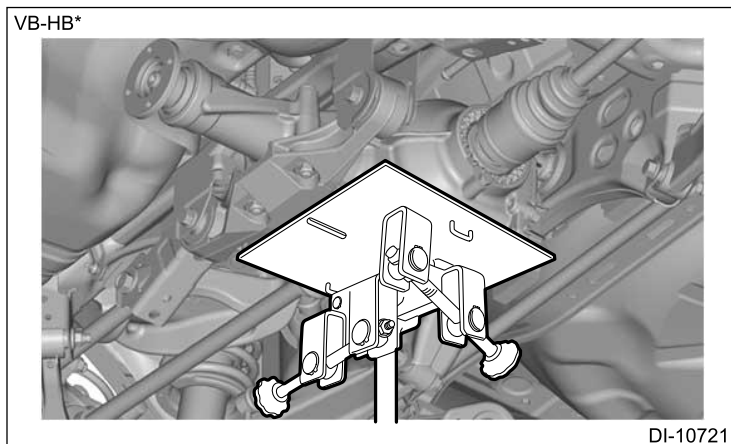
1. Check for oil leaks.
2. Check that there is no deformation, cracks or other damages.

DIFFERENTIALS > Rear Differential Front Member

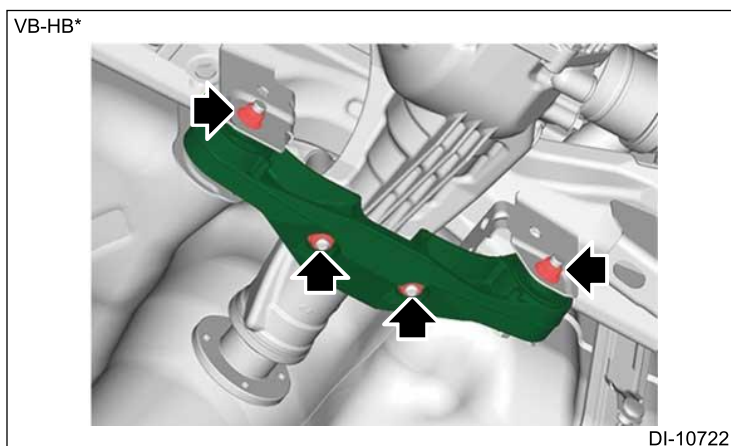
REMOVAL



1. Set the transmission jack.



2. Remove the rear differential front member.



DIFFERENTIALS > Rear Differential Front Member

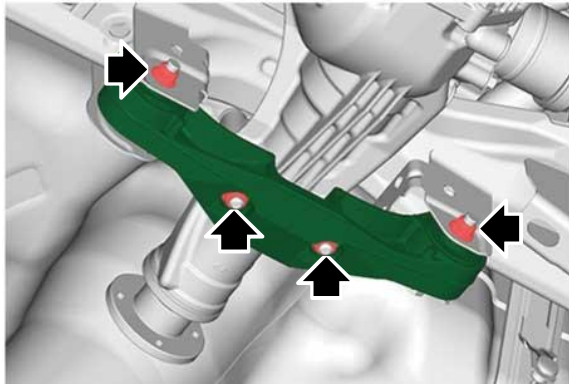
INSTALLATION

1. Temporarily install the rear differential front member.

Caution:

Be sure to use a new self-locking nut.

VB-HB*



DI-10722

2. Detach the transmission jack, and tighten the self-locking nut.

Caution:

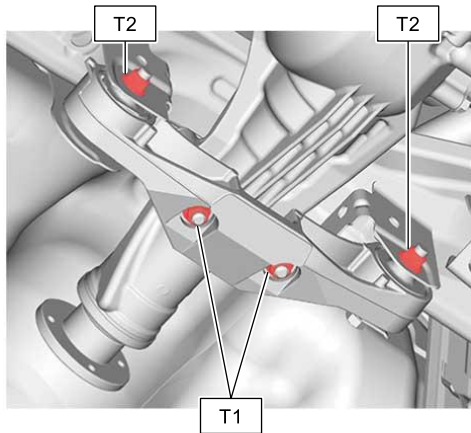
Be sure to detach the transmission jack, and tighten the self-locking nut with the rear differential seated under its own weight.

Tightening torque:

T1: 50 N·m (5.1 kgf-m, 36.9 ft-lb)

T2: 110 N·m (11.2 kgf-m, 81.1 ft-lb)

VB-HB*



DI-10724

DIFFERENTIALS > Rear Differential Front Member

INSPECTION


1. Check that there is no deformation, cracks or other damages.
2. Check for excessive rusting.
3. Check the bushing for crack or excessive hardening.

DIFFERENTIALS > Rear Differential Mount Bushing

REPLACEMENT

Caution:

Be sure to remove dirt and rust before work.

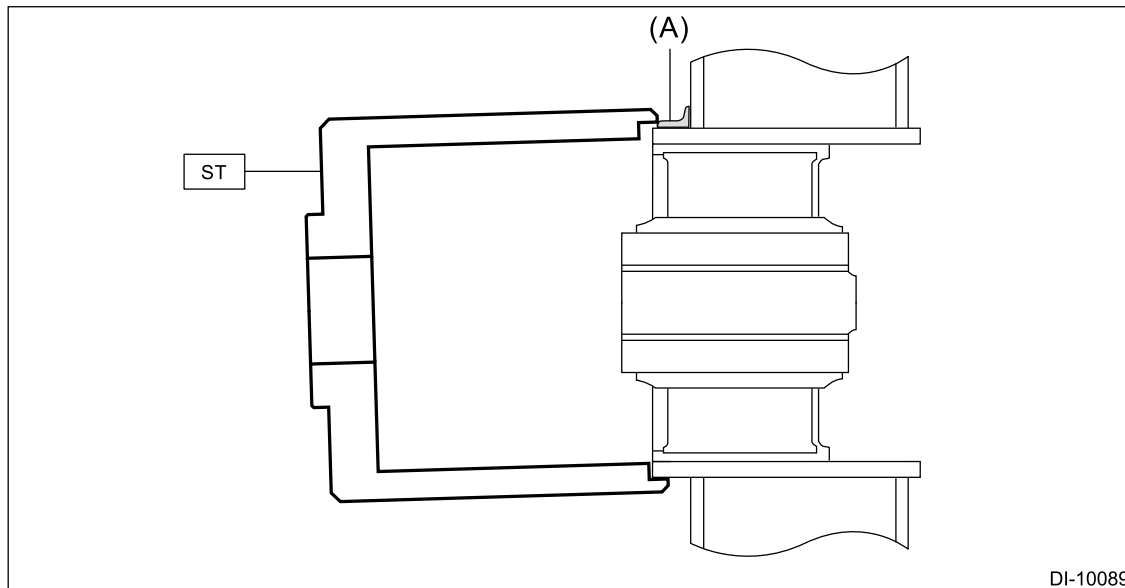
1. Remove the rear differential.  Ref. to [DIFFERENTIALS>Rear Differential \(VB-type\)>REMOVAL](#).
2. Fit the ST to the periphery of the sub frame cylinder, and make sure that the ST does not contact with welded spots (A) or spatters.

Caution:

If the ST rises on the welded spots (A) or spatters, the ST may be damaged during the operation. To avoid this, grind the excessive welds or spatters with a sander or equivalent so that the ST contacts the cylinder peripheral part.

Preparation tool:

ST: SPECIAL TOOL A (41399FG010)



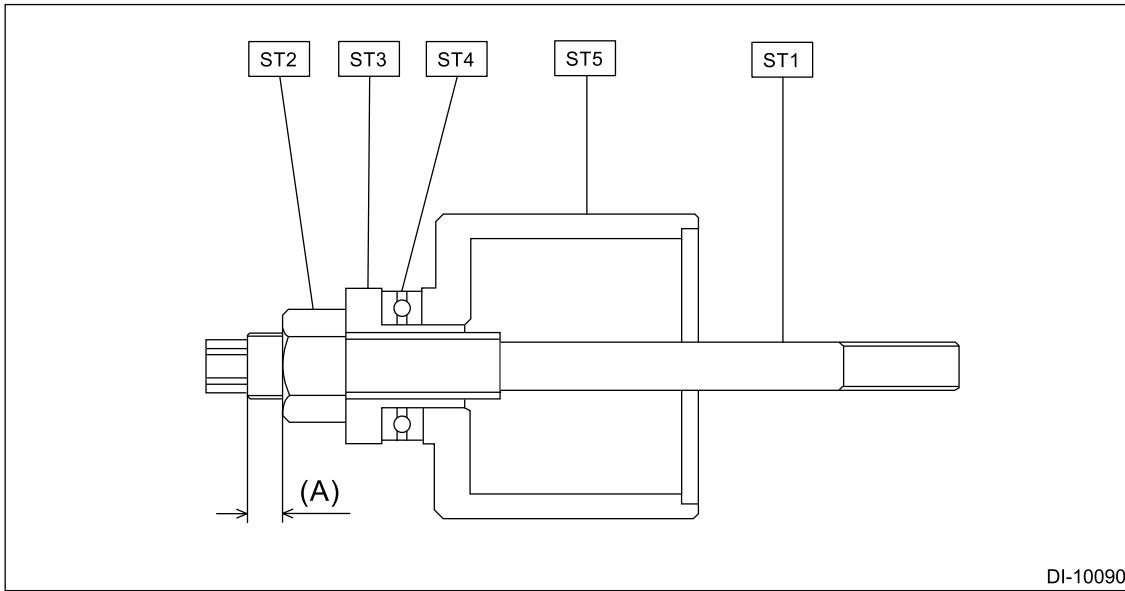
3. Set the ST1, ST2, ST3, ST4 and ST5 as shown in the figure.

Caution:

Apply the molybdenum grease on the thread of the ST.

Preparation tool:

ST1: SPECIAL TOOL SHAFT (41399FG091)
ST2: SPECIAL TOOL NUT (41399FG070)
ST3: SPECIAL TOOL SLEEVE (41399FG050)
ST4: SPECIAL TOOL BEARING (41399FG080)
ST5: SPECIAL TOOL A (41399FG010)



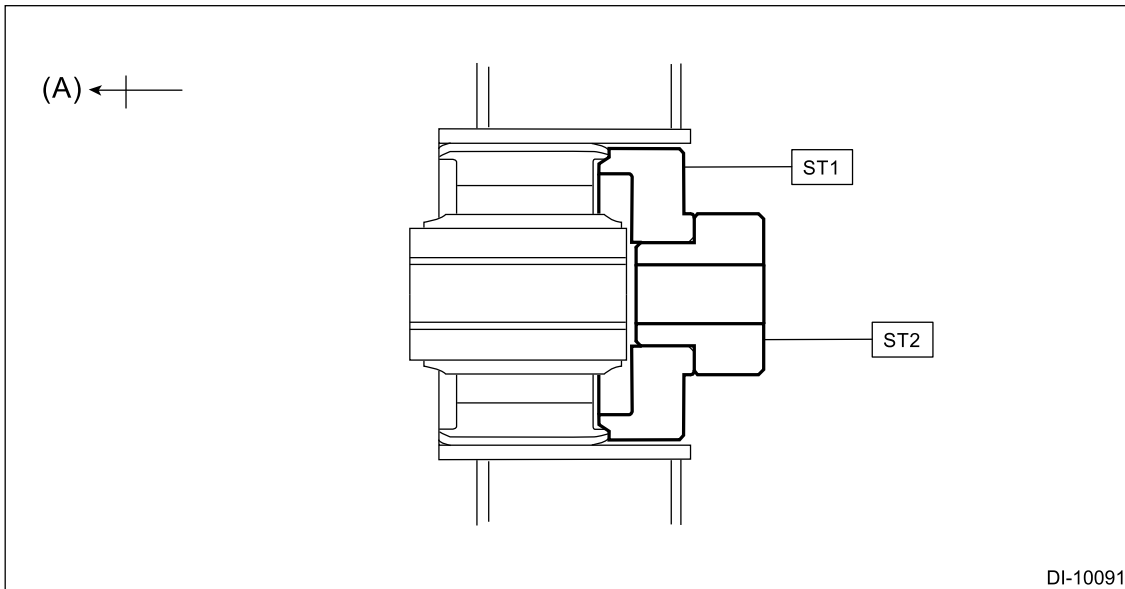
(A) 5 mm (0.2 in) or less

4. Set the ST1 and ST2 in the rear side of the rear differential mount bushing, and hold them.

Preparation tool:

ST1: SPECIAL TOOL C (41399FG031)

ST2: SPECIAL TOOL RING (41399FG061)



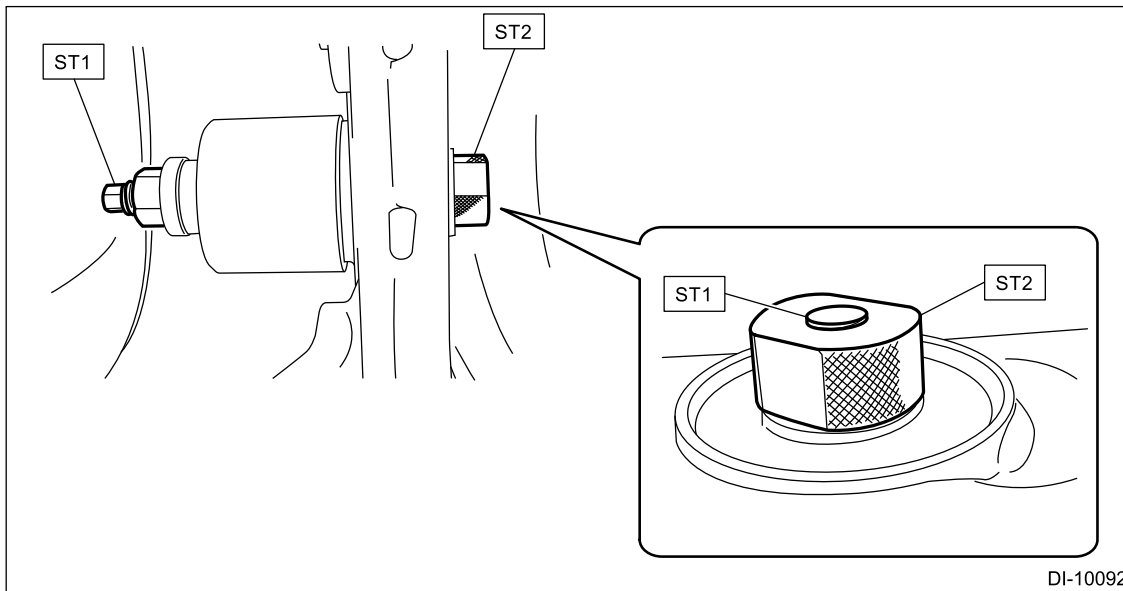
(A) Front side

5. Insert the ST set in step 3. through the rear differential mount bushing hole from the front side, and screw in the ST1 by hand till the front end of ST1 comes out from the rear end of ST2 by approx. 3.0 mm (0.12 in).

Preparation tool:

ST1: SPECIAL TOOL SHAFT (41399FG091)

ST2: SPECIAL TOOL RING (41399FG061)



6. Hold the ST1 to prevent it from rotating, and screw in the ST3 by hand till there is no loose fit on the ST2.

Caution:

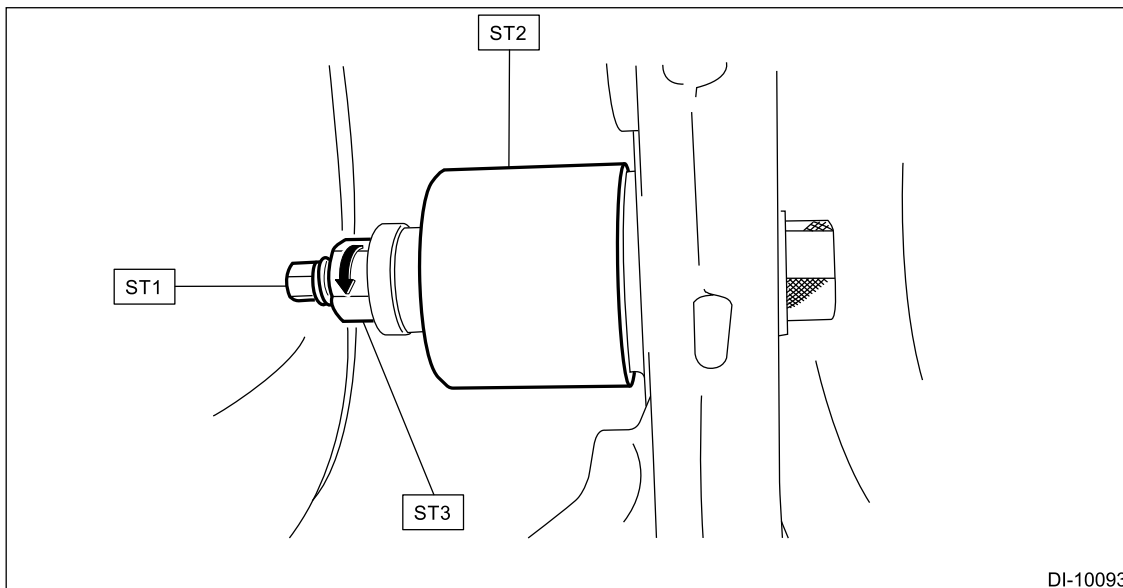
- Check that the ST2 contacts the cylinder circumference of the sub frame.
- Check that the ST is not tilted.

Preparation tool:

ST1: SPECIAL TOOL SHAFT (41399FG091)

ST2: SPECIAL TOOL A (41399FG010)

ST3: SPECIAL TOOL NUT (41399FG070)



7. Hold the ST1 with a tool to prevent it from rotating, and screw in the ST2 to remove the rear differential mount bushing.

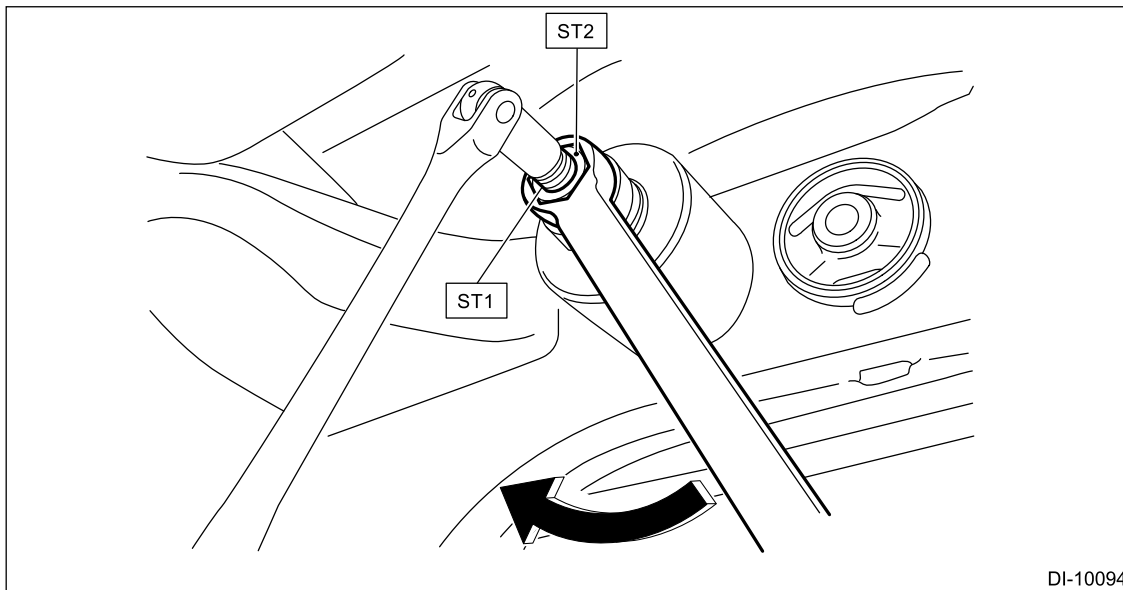
Caution:

- Rotation of ST1 will damage the ST. Never rotate the ST1.
- If the ST starts to tilt, stop the work and set the ST again.

Preparation tool:

ST1: SPECIAL TOOL SHAFT (41399FG091)

ST2: SPECIAL TOOL NUT (41399FG070)



8. Set the ST1, ST2, ST3, ST4, ST5 and rear differential mount bushing as shown in the figure.

Caution:

Apply the molybdenum grease on the thread of the ST.

Note:

- Set the ST2 nut near to the end of ST1 screw.
- Hold the rear differential mount bushing with the arrow marked side facing toward the rear side, and set the arrow mark facing upward.
- Mark the bottom end of rear differential mount bushing to identify the installing direction.

Preparation tool:

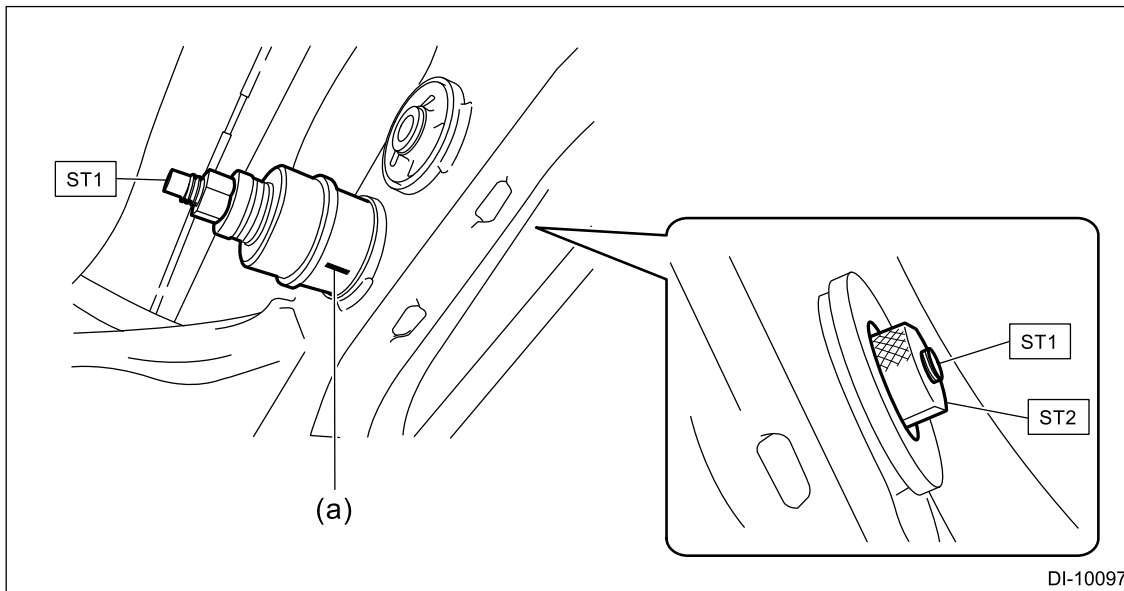
ST1: SPECIAL TOOL SHAFT (41399FG091)

ST2: SPECIAL TOOL NUT (41399FG070)

ST3: SPECIAL TOOL SLEEVE (41399FG050)

ST4: SPECIAL TOOL BEARING (41399FG080)

ST5: SPECIAL TOOL B (41399FG020)



11. Hold the ST1 to prevent it from rotating, and screw in the ST2 by hand till there is no loose fit on the ST and the rear differential mount bushing.

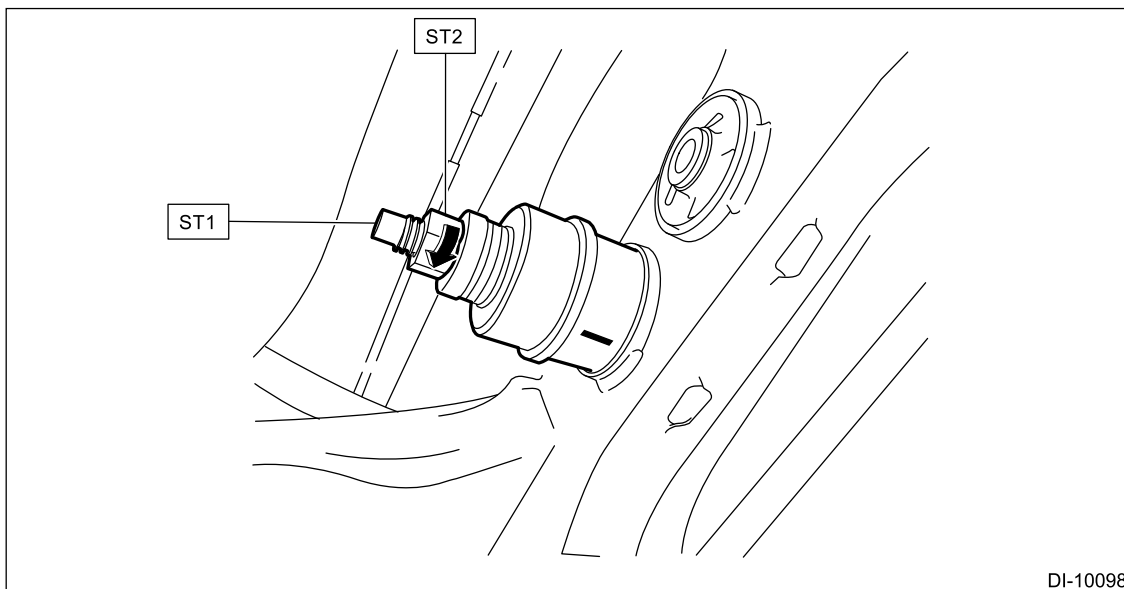
Caution:

Make sure that the ST and rear differential mount bushing are not tilted.

Preparation tool:

ST1: SPECIAL TOOL SHAFT (41399FG091)

ST2: SPECIAL TOOL NUT (41399FG070)



12. Screw in the ST2 while holding the ST1 with a tool to prevent it from rotating, and press-fit the rear differential mount bushing to the front end of sub frame cylinder.

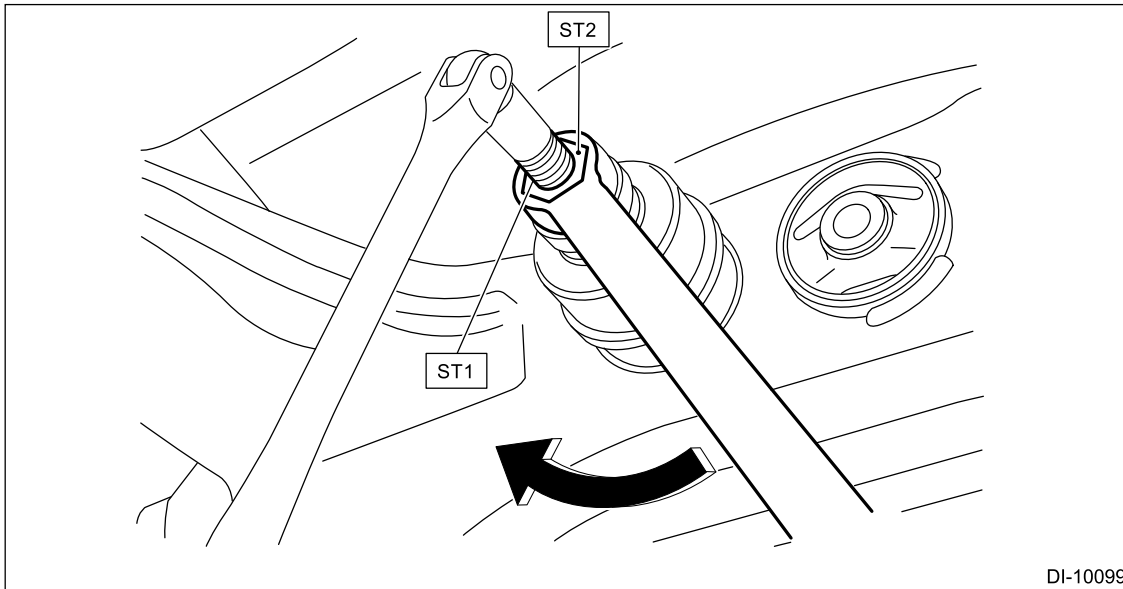
Caution:

- **Rotation of ST1 will damage the ST. Never rotate the ST1.**
- **If the ST starts to tilt, stop the work and set the ST again.**

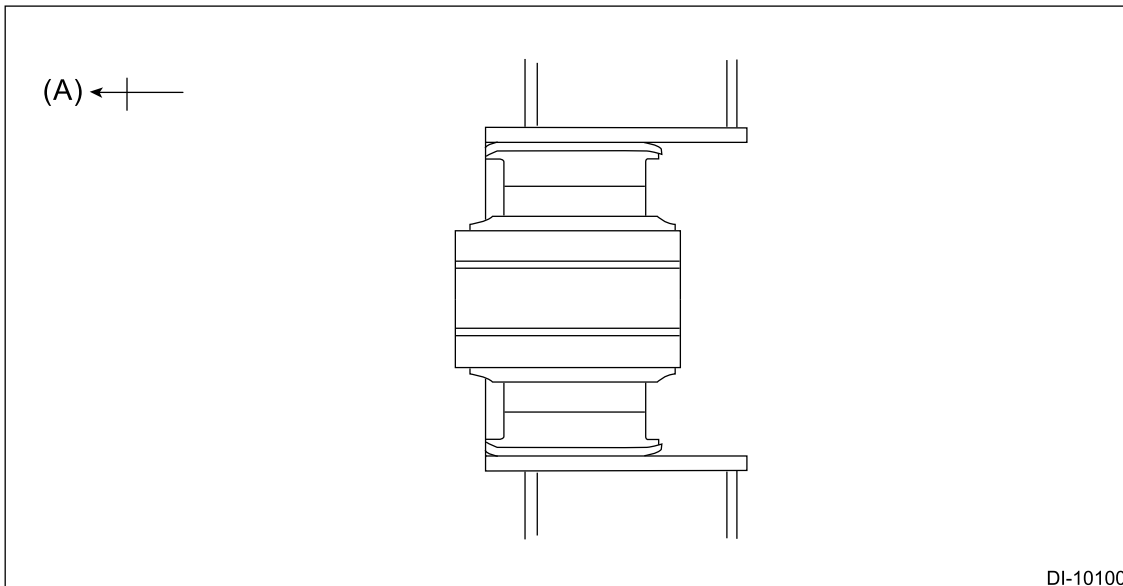
Preparation tool:

ST1: SPECIAL TOOL SHAFT (41399FG091)

ST2: SPECIAL TOOL NUT (41399FG070)



13. Make sure that the rear differential mount bushing is inserted to the front end of sub frame cylinder.



(A) Front side

14. Install the rear differential.  [Ref. to DIFFERENTIALS>Rear Differential \(VB-type\)>INSTALLATION.](#)

DIFFERENTIALS > Rear Differential Mount Bushing


INSPECTION

- 1.** Check that there is no deformation, cracks or other damages.
- 2.** Check the bushing for crack or excessive hardening.

DIFFERENTIALS > Symptoms and causes

INSPECTION

Caution:

- **If noise occurs, identify the cause before work.**
- **Check the control operation history.**  **Ref. to ENGINE (DIAGNOSTICS)(H4DOTC)>Work Support>OPERATION.**

Symptoms	Problem parts etc.	Possible cause
Noise when shifting from P range or N range or starting	Hypoid gear set	Excessive hypoid gear backlash
	Drive pinion or companion flange	Wear or damage at splines of drive pinion or companion flange
	Self-locking nut securing the companion flange	Loose self-locking nut
	Front bearing or rear bearing	Insufficient preload for front bearing or rear bearing
	Thrust washer	Excessive backlash between the differential bevel gear and differential bevel pinion
	Differential bevel gear	Wear or damage of the splines
	Pinion gear or pinion shaft	Wear or damage at connection of pinion gear and pinion shaft
	Rear differential front member or rear differential mount bushing	Excessive hardening or damage of rear differential front member and rear differential mount bushing
Noise when turning	Differential bevel gear, differential bevel pinion	Damaged gear
	Pinion shaft	Excessive wear or damage of pinion shaft
	Thrust washer	Excessive wear or damage of thrust washer
Noise when driving (under constant load)	Each bearing	Wear, damage or seizure of each bearing
	Each gear	Damage of each gear
Oil leakage from rear differential	Each oil seal	Wear or damage of each oil seal
	Differential gear oil	Excessive differential gear oil level

PROPELLER SHAFT / DRIVE SHAFT / AXLE

PDA

1. General Description
2. Propeller Shaft
3. Front Drive Shaft
4. Front Axle
5. Front Hub Unit Bearing
6. Rear Drive Shaft
7. Rear Axle
8. Rear Hub Unit Bearing
9. Symptoms and causes

PROPELLER SHAFT / DRIVE SHAFT / AXLE > General Description

CAUTION

- When performing service operation, refer to "Repair Contents" in "General Description". [Ref. to REPAIR CONTENTS>Repair Contents.](#)
- Prior to starting work, pay special attention to the following:
 1. Always wear work clothes, a work cap, and protective shoes. Additionally, wear a helmet, protective goggles, etc. if necessary.
 2. Protect the vehicle using a seat cover, fender cover, etc.
 3. Prepare the service tools, clean cloth, containers to catch grease and oil, etc.
- Prevent scattering of grease and oil. If it scatters, wipe it off immediately to prevent it from penetrating the floor or flowing out, to protect the environmental.
- If the grease and oil is spilt over the engine, exhaust pipe or the under cover, completely wipe it off to avoid emission of smoke or causing a fire.
- Vehicle components are extremely hot immediately after driving. Be wary of receiving burns from heated parts.
- When performing a repair, identify the cause of trouble and avoid unnecessary work.
- Before disconnecting connectors of sensors or units, be sure to disconnect the ground terminal from the battery sensor.
- Always use the jack-up point when the lifting device, shop jacks or rigid racks are used to support the vehicle.
- Before starting works, remove dirt and corrosion around the target area.
- Keep the removed parts in order and protect them from dust and dirt.
- All removed parts, if to be reused, should be reinstalled in the original positions with attention to the correct directions, etc.
- For the parts except for the non-reusable parts, replace them with new parts if necessary.
- Be sure to tighten bolts and nuts to the specified torque.
- Always use new application oil during work.
- Be sure that the brake disc and brake pad is free from grease or oil.

PROPELLER SHAFT / DRIVE SHAFT / AXLE > General Description

SPECIFICATION

1. PROPELLER SHAFT

Joint type			Cardan joint + Double offset constant velocity joint
Propeller shaft (front side) joint-to-joint length: L1	mm (in)	MT model	735.5 (28.96)
		CVT model	578.0 (22.76)
Propeller shaft (rear side) joint-to-joint length: L2	mm (in)		747.0 (29.41)
Outer diameter of tube:	mm (in)	D1	63.5 (2.50)
		D2	57.5 (2.26)

(A) Cardan joint

(B) Double offset constant velocity joint

2. FRONT DRIVE SHAFT

Joint type	IN side	Sliding tripod constant velocity joint
	OUT side	Rzeppa constant velocity joint
Axle length: L	mm (in)	360.7 (14.20)
Axle diameter: D	mm (in)	22.0 (0.87)

3. REAR DRIVE SHAFT

Joint type	IN side	Double offset constant velocity joint
	OUT side	Rzeppa constant velocity joint
Axle length: L	mm (in)	399.5 (15.73)

Axle diameter: D	mm (in)	22.0 (0.87)
------------------	---------	-------------

PROPELLER SHAFT / DRIVE SHAFT / AXLE > General Description

COMPONENT

1. PROPELLER SHAFT

(1) Propeller shaft (MT model)

(2) Propeller shaft (CVT model)

**Tightening torque: N·m (kgf-m,
ft-lb)**

T1: 31 (3.2, 22.9)

T2: 52 (5.3, 38.4)

2. FRONT AXLE AND FRONT DRIVE SHAFT

- | | |
|-----------------------|-----------------------------|
| (1) Circlip | (10) O-ring |
| (2) Outer race | (11) Shaft ASSY |
| (3) Snap ring | (12) Bolt |
| (4) Roller cassette | (13) Front axle housing |
| (5) Tripod | (14) Front brake back plate |
| (6) Circlip | (15) Hub bolt |
| (7) Boot band (large) | (16) Front hub unit bearing |
| (8) Boot (IN side) | (17) Axle nut |
| (9) Boot band (small) | |

Tightening torque: N·m (kgf-m, ft-lb)

T1: 18 (1.8, 13.3)

T2: 95 (9.7, 70.1)

T3: 220 (22.4, 162.3)

3. REAR AXLE AND REAR DRIVE SHAFT

(1) Outer race	(10) Boot band (small)	(19) Rear brake back plate (CVT model)
(2) Snap ring	(11) Boot (OUT side)	(20) Hub bolt
(3) Ball	(12) Boot band (large)	(21) Rear hub unit bearing
(4) Inner race	(13) Shaft ASSY	(22) Axle nut
(5) Cage	(14) Bolt	
(6) Circlip	(15) Rear axle housing (MT model)	Tightening torque: N·m (kgf-m, ft-lb)
(7) Boot band (large)	(16) Rubber bushing trailing link	T1: 85 (8.7, 62.7)
(8) Boot (IN side)	(17) Rear brake back plate (MT model)	T2: 190 (19.4, 140.1)
(9) Boot band (small)	(18) Rear axle housing (CVT model)*	

*: For CVT model, rubber bushing trailing link cannot be disassembled.

If the rubber bushing trailing link has been removed, replace the rear axle housing with a new part.

PROPELLER SHAFT / DRIVE SHAFT / AXLE > General Description

PREPARATION TOOL

1. SUBARU SPECIAL TOOL

ILLUSTRATION	TOOL NUMBER	DESCRIPTION	REMARKS
	926470000	AXLE SHAFT PULLER	Used for removing the drive shaft. Note: Used together with AXLE SHAFT PULLER PLATE (28099PA110).
	20099FG000	BUSHING REMOVER	Used for replacing the rubber bushing trailing link of rear axle housing. Note: Used together with base part of INSTALLER & REMOVER (20099PA010).
	20099PA010	INSTALLER & REMOVER	Used for replacing the rubber bushing trailing link of rear axle housing. Note: Used together with BUSHING REMOVER (20099FG000).
	28099AC000	BOOT BAND PLIER	Used for tightening the boot band of the front drive shaft.

ILLUSTRATION	TOOL NUMBER	DESCRIPTION	REMARKS
	28099PA080	HUB STAND	Used for press-fitting hub bolt.
	28099PA110	AXLE SHAFT PULLER PLATE	Exchange with the plate of the AXLE SHAFT PULLER (926470000) to use.
	28399AG000	HUB STAND	Used for extracting hub bolt.
	28399SA010	OIL SEAL PROTECTOR	Used for installing the front drive shaft.

ILLUSTRATION	TOOL NUMBER	DESCRIPTION	REMARKS
	—	SUBARU SELECT MONITOR 4	Used for setting of each function and troubleshooting for electrical system. Note: <ul style="list-style-type: none"> • For detailed operation procedures, refer to “Help” of application. • Used together with interface for Subaru Select Monitor (such as DST-i and DST-010).

2. OTHER

	REMARKS
Ball joint puller	Used for disconnecting joints.
Magnet stand	Used for measuring the propeller shaft and hub unit bearing. Note: Used together with dial gauge.
DIAL GAUGE	Used for measuring the propeller shaft and hub unit bearing. Note: Used together with magnet stand.
Crowbar	Used for removing the drive shaft.

PROPELLER SHAFT / DRIVE SHAFT / AXLE > Propeller Shaft

REMOVAL

1. Release the parking brake.
2. Release the shift lock and shift the select lever to the "N range". (CVT model) [_Ref. to CONTROL SYSTEMS>Select Lever>REMOVAL.](#)
3. Remove the rear exhaust pipe and center exhaust cover. [_Ref. to EXHAUST\(H4DOTC\)>Rear Exhaust Pipe>REMOVAL.](#)
4. Remove the center exhaust pipe (rear). [_Ref. to EXHAUST\(H4DOTC\)>Center Exhaust Pipe>REMOVAL > CENTER EXHAUST PIPE \(REAR\).](#)
5. Wrap a cloth, etc. at the point shown in the figure to protect the boot.

6. Place an alignment mark (A) on the joint portion of the propeller shaft and the rear differential.

7. Disconnect the propeller shaft and rear differential.

Caution:

Do not bend the joint of the propeller shaft more than required.

8. Remove the center bearing bolt and remove the propeller shaft.

Caution:

- Do not bend the joint of the propeller shaft more than required.
- Be careful not to damage the oil seal.
- After removal, protect the tip end with a cloth or the like.
- Prepare a container for draining of CVTF or the transmission gear oil.

9. Install an appropriate cap, etc. to the transmission.

Caution:

- Be careful not to damage the oil seal.

INSTALLATION

1. Apply transmission gear oil to the oil seal lip and propeller shaft sleeve yoke. (MT model)
2. Apply CVTF to the oil seal lip and propeller shaft sleeve yoke. (CVT model)
3. Insert the sleeve yoke into the transmission and attach center bearing bolt.

Caution:

Do not bend the joint of the propeller shaft more than required.

Tightening torque:

52 N·m (5.3 kgf-m, 38.4 ft-lb)

4. Align the alignment marks (A), and connect the propeller shaft and rear differential.

Tightening torque:

31 N·m (3.2 kgf-m, 22.9 ft-lb)

5. Install the center exhaust pipe (rear). [Ref. to EXHAUST\(H4DOTC\)>Center Exhaust Pipe>INSTALLATION > CENTER EXHAUST PIPE \(REAR\).](#)
6. Install the center exhaust cover and rear exhaust pipe. [Ref. to EXHAUST\(H4DOTC\)>Rear Exhaust Pipe>INSTALLATION.](#)
7. Release the shift lock and shift the select lever to the "P range". (CVT model) [Ref. to CONTROL SYSTEMS>Select Lever>INSTALLATION.](#)
8. Apply the parking brake.
9. Check the level of the transmission gear oil. (MT model) [Ref. to MANUAL TRANSMISSION AND DIFFERENTIAL\(TY75\)>Transmission Gear Oil>INSPECTION.](#)
10. Check the CVTF level. (CVT model) [Ref. to CONTINUOUSLY VARIABLE TRANSMISSION\(TR690\)>CVTF>INSPECTION.](#)

PROPELLER SHAFT / DRIVE SHAFT / AXLE > Propeller Shaft

DISASSEMBLY

Propeller shaft cannot be disassembled.

PROPELLER SHAFT / DRIVE SHAFT / AXLE > Propeller Shaft

INSPECTION

1. Check that there is no deformation, cracks or other damages.
2. Check each part for looseness and runout.

Note:

Check with the propeller shaft installed to the vehicle.

- (1) Release the shift lock and shift the select lever to the "N range". (CVT model) [Ref. to CONTROL SYSTEMS>Select Lever>REMOVAL.](#)
- (2) Remove the rear exhaust pipe. [Ref. to EXHAUST\(H4DOTC\)>Rear Exhaust Pipe>REMOVAL.](#)
- (3) Remove the center exhaust pipe (rear). [Ref. to EXHAUST\(H4DOTC\)>Center Exhaust Pipe>REMOVAL > CENTER EXHAUST PIPE \(REAR\).](#)
- (4) Check for looseness while moving the splines, universal joint section and center bearing by hand.

- (5) Measure the runout of the propeller shaft using a magnet stand and dial gauge.

Note:

- **Measurement must be performed at the center of the propeller shaft.**
- **When measuring, turn the rear tier to rotate the propeller shaft.**

Service limit:

Front side: 0.8 mm (0.03 in)

Rear side: 0.8 mm (0.03 in)

(6) Release the shift lock and shift the select lever to the "P range". (CVT model) [Ref. to CONTROL SYSTEMS>Select Lever>INSTALLATION.](#)

PROPELLER SHAFT / DRIVE SHAFT / AXLE > Front Drive Shaft

REMOVAL

Caution:

Do not loosen the axle nut while the front axle is loaded.

1. Disconnect the ground terminal from battery sensor. [Ref. to REPAIR CONTENTS>NOTE > BATTERY.](#)

Note:

Perform this procedure only when removing the LH side.

2. Remove the front wheels. [Ref. to WHEEL AND TIRE SYSTEM>Tire and Wheel>REMOVAL.](#)
3. Lift the crimped section of axle nut.

4. Remove the axle nut while depressing the brake pedal.
5. Drain the transmission gear oil. (MT model) [Ref. to MANUAL TRANSMISSION AND DIFFERENTIAL\(TY75\)>Transmission Gear Oil>REPLACEMENT.](#)
6. Drain differential gear oil. (CVT model) [Ref. to CONTINUOUSLY VARIABLE TRANSMISSION\(TR690\)>Differential Gear Oil>REPLACEMENT.](#)
7. Remove the crossmember support rear RH. [Ref. to FRONT SUSPENSION>Crossmember Support>REMOVAL.](#)

Note:

Perform this procedure only when removing the RH side.

8. Remove the center exhaust pipe (rear). [Ref. to EXHAUST\(H4DOTC\)>Center Exhaust Pipe>REMOVAL > CENTER EXHAUST PIPE \(REAR\).](#)

Note:

Perform this procedure only when removing the LH side.

9. Remove the brake hose bracket. [Ref. to FRONT SUSPENSION>Front Strut>REMOVAL.](#)

Note:

Remove only the brake hose bracket.

10. Disconnect the arm assembly front.
 - (1) Remove the bolt and nut from the front axle housing.
 - (2) Lower the arm assembly front, and remove the ball stud from the front axle housing.

Caution:

Be careful not to damage the boot of the ball joint.

11. Pull out the front drive shaft from the front hub unit bearing.

Caution:

- Be careful not to damage the spline portion of the front drive shaft.
- Be careful not to damage the front hub unit bearing.
- Be careful not to damage the boot of the joint.

Note:

- If it is hard to remove, use ST1 and ST2.
- When using the ST1 and ST2, remove the caliper body. [Ref. to BRAKE>Front Disc Brake Assembly>REMOVAL.](#)

Preparation tool:

ST1: AXLE SHAFT PULLER (926470000)

ST2: AXLE SHAFT PULLER PLATE (28099PA110)

12. Insert a crowbar, etc. between the differential side retainer and front drive shaft, and remove the front drive shaft.

Caution:

Be careful not to damage the peripheral parts.

PROPELLER SHAFT / DRIVE SHAFT / AXLE > Front Drive Shaft

INSTALLATION

Note:

When the front drive shaft is removed using the ST, install the caliper body. [Ref. to BRAKE>Front Disc Brake Assembly>INSTALLATION.](#)

1. Replace with a new differential side retainer oil seal.

MT model:

[_Ref. to MANUAL TRANSMISSION AND DIFFERENTIAL\(TY75\)>Differential Side Retainer Oil Seal>REPLACEMENT.](#)

CVT model:

[_Ref. to CONTINUOUSLY VARIABLE TRANSMISSION\(TR690\)>Differential Side Retainer Oil Seal>REPLACEMENT.](#)

2. Replace the circlip with a new part.
3. Apply transmission gear oil to the differential side retainer oil seal lip and front drive shaft insertion section. (MT model)
4. Apply differential gear oil to the differential side retainer oil seal lip and front drive shaft insertion section. (CVT model)
5. Set the ST to differential side retainer.

Preparation tool:

ST: OIL SEAL PROTECTOR (28399SA010)

6. Insert the front drive shaft spline section into transmission and remove the ST (OIL SEAL PROTECTOR).

Note:

Remove it before inserting the front drive shaft completely.

7. Insert the front drive shaft completely.
8. Insert the front drive shaft into the front hub unit bearing.

Caution:

- **Be careful not to damage the spline portion of the front drive shaft.**
- **Be careful not to damage the front hub unit bearing.**
- **Be careful not to damage the boot of the joint.**
- **Do not strike the front drive shaft with a hammer, etc.**

9. Connect the arm assembly front.

Caution:

- **Always use a new flange bolt and a new flange nut.**
- **While holding the bolt side, tighten the nut to the specified torque.**
- **Be careful not to damage the boot of the ball joint.**

Tightening torque:

70 N·m (7.1 kgf-m, 51.6 ft-lb)

- (a) Bottom surface of front axle housing
- (b) Front axle housing
- (c) Arm ASSY front

10. Install the brake hose bracket. [Ref. to FRONT SUSPENSION>Front Strut>INSTALLATION.](#)
11. Install the center exhaust pipe (rear). [Ref. to EXHAUST\(H4DOTC\)>Center Exhaust Pipe>INSTALLATION > CENTER EXHAUST PIPE \(REAR\).](#)
12. Install the crossmember support rear RH. [Ref. to FRONT SUSPENSION>Crossmember Support>INSTALLATION.](#)

13. Fill the transmission gear oil. (MT model) [Ref. to MANUAL TRANSMISSION AND DIFFERENTIAL\(TY75\)>Transmission Gear Oil>REPLACEMENT.](#)

14. Fill differential gear oil. (CVT model) [Ref. to CONTINUOUSLY VARIABLE TRANSMISSION\(TR690\)>Differential Gear Oil>REPLACEMENT.](#)

15. While depressing the brake pedal, install the axle nut.

Caution:

Be sure to use a new axle nut.

Tightening torque:

220 N·m (22.4 kgf-m, 162.3 ft-lb)

16. Crimp the axle nut.

17. Install the front wheels. [Ref. to WHEEL AND TIRE SYSTEM>Tire and Wheel>INSTALLATION.](#)

18. Connect the ground terminal to battery sensor. [Ref. to REPAIR CONTENTS>NOTE > BATTERY.](#)

19. Perform VDC sensor midpoint setting mode. [Ref. to VEHICLE DYNAMICS CONTROL \(VDC\)>VDC Control Module and Hydraulic Control Unit \(VDCCM&H/U\)>ADJUSTMENT > VDC SENSOR MIDPOINT SETTING MODE.](#)

20. Perform the lane keep assist learning value clear. (Models with EyeSight) [Ref. to EyeSight \(DIAGNOSTICS\)>Work Support.](#)

PROPELLER SHAFT / DRIVE SHAFT / AXLE > Front Drive Shaft

DISASSEMBLY

Note:

OUT side joint (Rzeppa constant velocity joint) and boot (OUT side) cannot be disassembled.

1. Place alignment marks (A) on the shaft assembly and outer race.

2. Remove the boot band (large) and boot band (small) and move the boot (IN side) to the central side of the shaft assembly.

Caution:

Be careful not to damage the boot (IN side).

3. Remove the circlip, and remove the outer race.

Caution:

Be careful not to let the roller cassette drop off.

4. Wipe off the grease and place identification marks on the roller cassette and the tripod.

5. Remove the roller cassette.
6. Wipe off the grease and place alignment marks (A) on the tripod and shaft assembly.

7. Remove the snap ring and then remove the tripod.

8. Remove the boot (IN side).

Caution:

Be sure to wrap the shaft assembly splines with vinyl tape, etc. to protect the boot (IN side) from scratches.

9. Remove the O-ring from the shaft assembly.

10. Clean each part.

Caution:

Be careful not to erase the identification and alignment marks.

PROPELLER SHAFT / DRIVE SHAFT / AXLE > Front Drive Shaft

ASSEMBLY

1. Pass the boot band (small), boot (IN side) and circlip through the shaft assembly.

Caution:

Be sure to wrap the shaft assembly splines with vinyl tape, etc. to protect the boot (IN side) from scratches.

(A) Boot band (small)

(B) Boot (IN side)

(C) Circlip

2. Roll up a thick piece of paper to a size where the shaft assembly can pass through, and affix with tape to form a cylinder.

3. Set a new O-ring on this cylinder.

Caution:

- **Be careful not to damage the O-ring.**
- **Make sure to install the O-ring so that it does not twist.**
- **Do not stretch the O-ring to 30 mm (1.2 in) or more in an inner diameter.**

(A) O-ring

(B) Cylinder material

4. Pass the cylinder material through the shaft assembly.

(A) Shaft ASSY

(B) Cylinder material

(C) O-ring

5. Slide the cylinder material to the shaft assembly boot groove, and move the O-ring from the cylinder material onto the shaft assembly boot groove.

Caution:

- **Attach the O-ring to the shaft assembly boot groove center.**
- **Make sure to install the O-ring so that it does not twist.**
- **Check that the O-ring does not become scratched and that there are no foreign objects attached to it.**

(A) Shaft ASSY

(C) O-ring

(D) Boot groove

(B) Cylinder material

6. Remove the cylinder material.
7. Align alignment marks (A), set the tripod and install the snap ring.

Caution:

Pull the shaft assembly lightly and assure that the snap ring is completely fitted.

8. Apply 100 — 110 g (3.5 — 3.9 oz) of grease into the interior of outer race.

Preparation items:

Grease: NKG302 or the equivalent

9. Apply a thin coat of grease to the roller cassette and roller cassette installing area of the tripod.

Preparation items:

Grease: NKG302 or the equivalent

10. Align identification marks, and install the roller cassette.

11. Align alignment marks (A), set the outer race and install the circlip.

Caution:

Pull the shaft assembly lightly and assure that the circlip is completely fitted.

12. Apply 45 — 50 g (1.6 — 1.8 oz) of grease evenly to the entire inner surface of boot (IN side).

Preparation items:

Grease: NKG302 or the equivalent

13. Install the boot (IN side).

Caution:

- **Do not twist the boot (IN side).**
- **Completely remove any grease that comes out and adheres to the outer surface of the boot (IN side).**
- **Check that it fits in the boot groove securely.**

(A) Shaft ASSY

(C) O-ring

(D) Boot groove

(B) Boot (IN side)

14. Set the new boot band (large) and new boot band (small).

15. Tighten the boot band (large) and boot band (small) using the ST.

Caution:

The boot band (large) and boot band (small) are to be tightened so that the omega shaped part is at the position indicated in the figure.

(A) Omega shaped part

(B) Boot band

(C) Outer race

Tightening torque:

Boot band (large)

178 N·m (18.2 kgf-m, 131.3 ft-lb)

Boot band (small)

145 N·m (14.8 kgf-m, 106.9 ft-lb)

Preparation tool:

ST: BOOT BAND PLIER (28099AC000)

(A) Boot band

(B) Torque wrench

(C) Spinner handle, etc.

16. Extend and retract the boot (IN side) repeatedly so that grease is spread evenly.

PROPELLER SHAFT / DRIVE SHAFT / AXLE > Front Drive Shaft

INSPECTION

- 1.** Check that there is no deformation, cracks or other damages.
- 2.** Check for grease leakage.
- 3.** Check the joint for looseness.
- 4.** Check for excessive wear.
- 5.** Check for excessive rusting.

PROPELLER SHAFT / DRIVE SHAFT / AXLE > Front Axle

REMOVAL



Caution:

Do not loosen the axle nut while the front axle is loaded.

1. Remove the front wheels. [_Ref. to WHEEL AND TIRE SYSTEM>Tire and Wheel>REMOVAL.](#)
2. Lift the crimped section of axle nut.

3. Remove the axle nut while depressing the brake pedal.
4. Remove the front disc rotor. [_Ref. to BRAKE>Front Disc Rotor>REMOVAL.](#)
5. Remove the front brake back plate.

6. Remove the sensor sub assembly front.

Caution:

- **Be careful not to damage the sensor.**
- **Do not apply excessive force to the sensor harness.**

7. Disconnect the tie-rod end. [Ref. to POWER ASSISTED SYSTEM \(POWER STEERING\)>Tie-rod end>REMOVAL.](#)

8. Loosen the flange nuts.

(1) Place an alignment mark (A) on the adjusting bolt and the strut assembly.

(2) Loosen the flange nuts of the strut assembly.

Caution:

Loosen the nut side while holding the bolt side.

9. Disconnect the arm assembly front.

(1) Remove the bolt and nut from the front axle housing.

(2) Lower the arm assembly front, and remove the ball stud from the front axle housing.

Caution:

Be careful not to damage the boot of the ball joint.

10. Pull out the front drive shaft from the front hub unit bearing.

Caution:

- Be careful not to damage the spline portion of the front drive shaft.
- Be careful not to damage the front hub unit bearing.
- Be careful not to damage the boot of the joint.

Note:

If it is hard to remove, use ST1 and ST2.

Preparation tool:

ST1: AXLE SHAFT PULLER (926470000)

ST2: AXLE SHAFT PULLER PLATE (28099PA110)

11. Hang the front drive shaft with a string, etc.

12. Remove the front axle housing.

Caution:

Since the front axle housing is heavy, be careful not to drop it.

13. Remove the front hub unit bearing. [Ref. to PROPELLER SHAFT / DRIVE SHAFT / AXLE>Front Hub Unit Bearing>REMOVAL.](#)

PROPELLER SHAFT / DRIVE SHAFT / AXLE > Front Axle

INSTALLATION

- 1.** Install the front hub unit bearing. [Ref. to PROPELLER SHAFT / DRIVE SHAFT / AXLE>Front Hub Unit Bearing>INSTALLATION.](#)
- 2.** Temporarily install the front axle housing.

Caution:

- **Always use a new flange nut.**
- **Do not forget to install the adjusting washer.**

- 3.** Insert the front drive shaft into the front hub unit bearing.

Caution:

- **Be careful not to damage the spline portion of the front drive shaft.**
- **Be careful not to damage the front hub unit bearing.**
- **Be careful not to damage the boot of the joint.**
- **Do not strike the front drive shaft with a hammer, etc.**

- 4.** Connect the arm assembly front.

Caution:

- **Always use a new flange bolt and a new flange nut.**
- **While holding the bolt side, tighten the nut to the specified torque.**
- **Be careful not to damage the boot of the ball joint.**

Tightening torque:

70 N·m (7.1 kgf-m, 51.6 ft-lb)

- (a) Bottom surface of front axle housing
- (b) Front axle housing
- (c) Arm ASSY front

- 5.** Align the alignment marks (A) on the adjusting bolt for the strut assembly and the strut, and tighten the flange nut.

Caution:

While holding the bolt side, tighten the nut to the specified torque.

Note:

First, tighten the adjusting bolt (upper side) to the specified torque.

Tightening torque:

155 N·m (15.8 kgf-m, 114.3 ft-lb)

6. Connect the tie-rod ends. [Ref. to POWER ASSISTED SYSTEM \(POWER STEERING\)>Tie-rod end>INSTALLATION.](#)

7. Install the sensor sub assembly front.

Tightening torque:

7.5 N·m (0.8 kgf-m, 5.5 ft-lb)

8. Install the front brake back plate.

Tightening torque:

18 N·m (1.8 kgf-m, 13.3 ft-lb)

9. Install the front disc rotor. [Ref. to BRAKE>Front Disc Rotor>INSTALLATION.](#)

10. While depressing the brake pedal, install the axle nut.

Caution:

Be sure to use a new axle nut.

Tightening torque:

220 N·m (22.4 kgf-m, 162.3 ft-lb)

11. Crimp the axle nut.

12. Install the front wheels. [Ref. to WHEEL AND TIRE SYSTEM>Tire and Wheel>INSTALLATION.](#)

13. Inspect the wheel alignment and adjust if necessary. [Ref. to FRONT SUSPENSION>Wheel Alignment>INSPECTION.](#)

14. Perform VDC sensor midpoint setting mode. [Ref. to VEHICLE DYNAMICS CONTROL \(VDC\)>VDC Control Module and Hydraulic Control Unit \(VDCCM&H/U\)>ADJUSTMENT > VDC SENSOR MIDPOINT SETTING MODE.](#)

15. Perform the lane keep assist learning value clear. (Models with EyeSight) [Ref. to EyeSight \(DIAGNOSTICS\)>Work Support.](#)

PROPELLER SHAFT / DRIVE SHAFT / AXLE > Front Axle

INSPECTION

- 1.** Check that there is no deformation, cracks or other damages.
- 2.** Check for excessive rusting.

PROPELLER SHAFT / DRIVE SHAFT / AXLE > Front Hub Unit Bearing

REMOVAL



Caution:

Do not loosen the axle nut while the front axle is loaded.

1. Remove the front wheels. [Ref. to WHEEL AND TIRE SYSTEM>Tire and Wheel>REMOVAL.](#)
2. Lift the crimped section of axle nut.

3. Remove the axle nut while depressing the brake pedal.
4. Remove the front disc rotor. [Ref. to BRAKE>Front Disc Rotor>REMOVAL.](#)
5. Remove the front hub unit bearing.

Caution:

- **Be careful not to damage the front hub unit bearing.**
- **Do not get closer the tool which charged magnetism to the front hub unit bearing.**

PROPELLER SHAFT / DRIVE SHAFT / AXLE > Front Hub Unit Bearing

INSTALLATION

1. Install the front hub unit bearing.

Caution:

- Always use a new bolt.
- Be careful not to damage the spline portion of the front drive shaft.
- Be careful not to damage the front hub unit bearing.
- Do not get closer the tool which charged magnetism to the front hub unit bearing.

Tightening torque:

95 N·m (9.7 kgf-m, 70.1 ft-lb)

2. Install the front disc rotor. [Ref. to BRAKE>Front Disc Rotor>INSTALLATION.](#)
3. While depressing the brake pedal, install the axle nut.

Caution:

Be sure to use a new axle nut.

Tightening torque:

220 N·m (22.4 kgf-m, 162.3 ft-lb)

4. Crimp the axle nut.

5. Install the front wheels. [Ref. to WHEEL AND TIRE SYSTEM>Tire and Wheel>INSTALLATION.](#)

PROPELLER SHAFT / DRIVE SHAFT / AXLE > Front Hub Unit Bearing

DISASSEMBLY

Using the ST or a press, push out the hub bolt (B) from the front hub unit bearing (A).

Caution:

Be careful not to use a hammer, etc. to tap the hub bolts. This may deform the front hub unit bearing.

Note:

Front hub unit bearing cannot be disassembled.

Preparation tool:

ST: HUB STAND (28399AG000)

PROPELLER SHAFT / DRIVE SHAFT / AXLE > Front Hub Unit Bearing

ASSEMBLY

1. Set the front hub unit bearing and hub bolt to the ST.

Caution:

Always use a new hub bolt.

Preparation tool:

ST: HUB STAND (28099PA080)

2. Using a press, press the hub bolt (B) until its seating surface contacts the hub unit bearing (A).

Note:

Use the 12 mm (0.5 in) dia. holes of ST to prevent bolts from tilting.

PROPELLER SHAFT / DRIVE SHAFT / AXLE > Front Hub Unit Bearing

INSPECTION

1. Check that there is no deformation, cracks or other damages.
2. Check for excessive rusting.
3. Check the following items by turning the front tires by hand.
 - Check for smooth rotation.
 - Check for noise.
4. Check the front hub unit bearing for looseness.
 - (1) Rock the front tire as shown in the figure.
 - Looseness exists → Go to next step.
 - No looseness → Normal (Perform step 5 if precise inspection is required.)

(2) Check the play with the brake pedal depressed using the same procedure as step (1).

- Looseness exists → Check the ball joint, each bushing, front suspension and front axle housing.
 - No looseness → Replace the front hub unit bearing.
5. To perform a precise inspection, use a magnet stand and dial gauge to check for looseness in the axial direction of the front hub unit bearing.

Service limit:

0.05 mm (0.002 in)

PROPELLER SHAFT / DRIVE SHAFT / AXLE > Rear Drive Shaft

REMOVAL

Caution:

Do not loosen the axle nut while the rear axle is loaded.

1. Release the parking brake.
2. Execute the brake maintenance mode. (CVT model) [Ref. to PARKING BRAKE>Parking Brake System>OPERATION > BRAKE MAINTENANCE MODE.](#)
3. Release the shift lock and shift the select lever to the "N range". (CVT model) [Ref. to CONTROL SYSTEMS>Select Lever>REMOVAL.](#)
4. Disconnect the ground terminal from battery sensor. [Ref. to REPAIR CONTENTS>NOTE > BATTERY.](#)
5. Remove the rear wheels. [Ref. to WHEEL AND TIRE SYSTEM>Tire and Wheel>REMOVAL.](#)
6. Lift the crimped section of axle nut.

7. Remove the axle nut while depressing the brake pedal.
8. Drain differential gear oil. [Ref. to DIFFERENTIALS>Differential Gear Oil>REPLACEMENT.](#)
9. Remove the rear differential. [Ref. to DIFFERENTIALS>Rear Differential \(VB-type\)>REMOVAL.](#)

Caution:

If the circlip is adhered to the rear drive shaft, overhaul the differential case. [Ref. to DIFFERENTIALS>Rear Differential \(VB-type\)>DISASSEMBLY.](#)

10. Pull out the rear drive shaft from the rear hub unit bearing.

Caution:

- **Be careful not to damage the spline portion of the rear drive shaft.**
- **Be careful not to damage the rear hub unit bearing.**

Note:

- **If it is hard to remove, use ST1 and ST2.**
- **When using the ST1 and ST2, remove the caliper body. [Ref. to BRAKE>Rear Disc Brake Assembly>REMOVAL.](#)**

Preparation tool:

ST1: AXLE SHAFT PULLER (926470000)

ST2: AXLE SHAFT PULLER PLATE (28099PA110)

PROPELLER SHAFT / DRIVE SHAFT / AXLE > Rear Drive Shaft

INSTALLATION

Note:

When the rear drive shaft is removed using the ST, install the caliper body. [Ref. to BRAKE>Rear Disc Brake Assembly>INSTALLATION.](#)

1. Replace with a new differential side retainer oil seal. [Ref. to DIFFERENTIALS>Differential Side Retainer Oil Seal>REPLACEMENT.](#)

2. Insert the rear drive shaft into the rear hub unit bearing.

Caution:

- Be careful not to damage the spline portion of the rear drive shaft.
- Be careful not to damage the rear hub unit bearing.
- Do not strike the rear drive shaft with a hammer, etc.

3. Temporarily attach the axle nut.

Caution:

Be sure to use a new axle nut.

4. Install the rear differential. [Ref. to DIFFERENTIALS>Rear Differential \(VB-type\)>INSTALLATION.](#)
5. Fill differential gear oil. [Ref. to DIFFERENTIALS>Differential Gear Oil>REPLACEMENT.](#)
6. While depressing the brake pedal, tighten the axle nut.

Tightening torque:

190 N·m (19.4 kgf-m, 140.1 ft-lb)

7. Crimp the axle nut.

- 8.** Install the rear wheels. [Ref. to WHEEL AND TIRE SYSTEM>Tire and Wheel>INSTALLATION.](#)
- 9.** Release the shift lock and shift the select lever to the "P range". (CVT model) [Ref. to CONTROL SYSTEMS>Select Lever>INSTALLATION.](#)
- 10.** Connect the ground terminal to battery sensor. [Ref. to REPAIR CONTENTS>NOTE > BATTERY.](#)
- 11.** Exit the brake maintenance mode. (CVT model) [Ref. to PARKING BRAKE>Parking Brake System>OPERATION > BRAKE MAINTENANCE MODE.](#)
- 12.** After the operation is completed, apply and release the parking brake five times and ensure that the brake operates normally.
- 13.** Apply the parking brake.

PROPELLER SHAFT / DRIVE SHAFT / AXLE > Rear Drive Shaft

DISASSEMBLY

- 1.** Place alignment marks (A) on the shaft assembly and outer race.

- 2.** Remove the boot band (large) and boot band (small) and move the boot (IN side) to the central side of the shaft assembly.

Caution:

Be careful not to damage the boot (IN side).

3. Remove the circlip, and remove the outer race.

Caution:

Be careful not to drop the ball.

4. Remove the ball.

Caution:

Be careful not to lose the ball.

5. Rotate the cage by a half pitch to shift to the central side of the shaft assembly.

6. Wipe off the grease and place alignment marks (A) on the inner race and shaft assembly.

7. Remove the snap ring, and remove the inner race.

8. Remove the cage.

9. Remove the boot (IN side).

Caution:

Be sure to wrap the shaft assembly splines with vinyl tape, etc. to protect the boot (IN side) from scratches.

10. Remove the boot band (large) and boot band (small) and remove the boot (OUT side).

Caution:

Be sure to wrap the shaft assembly splines with vinyl tape, etc. to protect the boot (OUT side) from scratches.

Note:

OUT side joint (Rzeppa constant velocity joint) cannot be disassembled.

- 11.** Clean each part.

Caution:

Be careful not to erase the alignment marks.

PROPELLER SHAFT / DRIVE SHAFT / AXLE > Rear Drive Shaft

ASSEMBLY

- 1.** Pass the boot (OUT side) through the shaft assembly.

Caution:

Be sure to wrap the shaft assembly splines with vinyl tape, etc. to protect the boot (OUT side) from scratches.

- 2.** Apply 30 — 45 g (1.1 — 1.6 oz) of grease to the boot (OUT side).

Preparation items:

Grease: NKG814 or the equivalent

- 3.** Install the boot (OUT side).

Caution:

- **Do not twist the boot.**
- **Completely remove any grease that comes out and adheres to the outer surface of the boot (OUT side).**
- **Check that it fits in the boot groove securely.**

4. Install the new boot band (large) and boot band (small).
5. Extend and retract the boot (OUT side) repeatedly so that grease is spread evenly.
6. Pass the boot band (small) and boot (IN side) through the shaft assembly.

Caution:

Be sure to wrap the shaft assembly splines with vinyl tape, etc. to protect the boot (IN side) from scratches.

7. Pass the cage through the shaft assembly.

Note:

Insert with its narrow part facing toward the boot (IN side).

8. Set the inner race by aligning the alignment marks (A), and install the snap ring.

Caution:

Check that the snap ring is completely fitted.

9. Install the cage to the inner race.

Note:

Insert by aligning the cage side face hole and the inner race protrusion and secure it by turning the cage by a half pitch.

10. Apply 55 — 65 g (1.9 — 2.3 oz) of grease into the interior of outer race.

Preparation items:

Grease: NKG814 or the equivalent

11. Apply a thin coat of grease to the ball and ball installation portion of the cage.

Preparation items:

Grease: NKG814 or the equivalent

12. Set the ball to the cage.

Caution:

Be careful not to drop the ball.

13. Align alignment marks (A), set the outer race and install the circlip.

Caution:

Pull the shaft assembly lightly and assure that the circlip is completely fitted.

14. Apply 20 – 25 g (0.7 – 0.9 oz) of grease evenly to the entire inner surface of boot (IN side).

Preparation items:

Grease: NKG814 or the equivalent

15. Install the boot (IN side).

Caution:

- **Do not twist the boot (IN side).**
- **Completely remove any grease that comes out and adheres to the outer surface of the boot (IN side).**
- **Check that it fits in the boot groove securely.**

(A) Boot (IN side)

(B) Shaft ASSY

(C) Boot groove

16. Install the new boot band (large) and boot band (small).

17. Extend and retract the boot (IN side) repeatedly so that grease is spread evenly.

PROPELLER SHAFT / DRIVE SHAFT / AXLE > Rear Drive Shaft

INSPECTION

- 1.** Check that there is no deformation, cracks or other damages.
- 2.** Check for grease leakage.
- 3.** Check the joint for looseness.
- 4.** Check for excessive wear.
- 5.** Check for excessive rusting.

PROPELLER SHAFT / DRIVE SHAFT / AXLE > Rear Axle

REMOVAL



Caution:

Do not loosen the axle nut while the rear axle is loaded.

1. Release the parking brake.
2. Execute the brake maintenance mode. (CVT model) [_Ref. to PARKING BRAKE>Parking Brake System>OPERATION > BRAKE MAINTENANCE MODE.](#)
3. Release the shift lock and shift the select lever to the "N range". (CVT model) [_Ref. to CONTROL SYSTEMS>Select Lever>REMOVAL.](#)
4. Disconnect the ground terminal from battery sensor. [_Ref. to REPAIR CONTENTS>NOTE > BATTERY.](#)
5. Remove the rear wheels. [_Ref. to WHEEL AND TIRE SYSTEM>Tire and Wheel>REMOVAL.](#)
6. Lift the crimped section of axle nut.

7. Remove the axle nut while depressing the brake pedal.
8. Remove the sensor sub assembly rear.

Caution:

- **Be careful not to damage the sensor.**
- **Do not apply excessive force to the sensor harness.**

9. Remove the parking brake assembly. (MT model) [_Ref. to PARKING BRAKE>Parking Brake Assembly \(Rear Disc Brake\)>REMOVAL > EXCEPT FOR THE ELECTRONIC PARKING BRAKE MODEL.](#)

10. Disconnect the bracket. (MT model)

11. Remove the clamp hand brake cable, and disconnect the cable assembly hand brake. (MT model)

12. Remove the rear disc rotor. (CVT model) [Ref. to BRAKE>Rear Disc Rotor>REMOVAL.](#)

13. Disconnect the adapter cord EPB bracket. (CVT model)

14. Disconnect the rear lateral link assembly front.

- MT model

1. Remove the snap pin (A) and nut (B).
2. Separate the rear axle housing and the ball joint (C) using the ball joint puller (D).

Caution:

- **Be careful not to damage the boot of the ball joint.**
- **Be careful not to damage the peripheral parts.**

Note:

Securely hook the ball joint puller (D) to the rear axle housing.

- CVT model
 1. Remove the snap pin (A), nut (B), and washer (C).
 2. Separate the rear axle housing and the ball joint (D) using the ball joint puller (E).

Caution:

- **Be careful not to damage the boot of the ball joint.**
- **Be careful not to damage the peripheral parts.**

Note:

Securely hook the ball joint puller (E) to the collar (F).

15. Disconnect the trailing link assembly rear.

16. Disconnect the rear lateral link assembly rear (D).

- (1) Disconnect the rear axle housing (A).
- (2) Disconnect the shock absorber assembly rear (B).
- (3) Disconnect the stabilizer link rear (C).

17. Pull out the rear drive shaft from the rear hub unit bearing.

Caution:

- **Be careful not to damage the spline portion of the rear drive shaft.**
- **Be careful not to damage the rear hub unit bearing.**

Note:

If it is hard to remove, use ST1 and ST2.

Preparation tool:

ST1: AXLE SHAFT PULLER (926470000)

ST2: AXLE SHAFT PULLER PLATE (28099PA110)

18. Hang the rear drive shaft with a string, etc.

19. Remove the rear axle housing.

Caution:

- **Since the rear axle housing is heavy, be careful not to drop it.**
- **Be careful not to damage the boot of the ball joint.**

20. Remove the rear hub unit bearing. [Ref. to PROPELLER SHAFT / DRIVE SHAFT / AXLE>Rear Hub Unit Bearing>REMOVAL.](#)

PROPELLER SHAFT / DRIVE SHAFT / AXLE > Rear Axle

INSTALLATION

1. Install the rear hub unit bearing. [Ref. to PROPELLER SHAFT / DRIVE SHAFT / AXLE>Rear Hub Unit Bearing>INSTALLATION.](#)

2. Temporarily install the rear axle housing.

(1) Temporarily install to the rear lateral link assembly front (A).

Caution:

- **Make sure there is no clearance between rear axle housing and collar. (CVT model)**
- **If the collar comes off from the rear axle housing, replace the rear axle housing with a new part. (CVT model)**
- **Do not forget to install the washer. (CVT model)**
- **Be careful not to damage the boot of the ball joint.**

(2) Insert the rear drive shaft (B).

Caution:

- Be careful not to damage the spline portion of the rear drive shaft.
- Be careful not to damage the rear hub unit bearing.
- Do not strike the rear drive shaft with a hammer, etc.

(3) Temporarily install to the arm assembly rear upper (C).

Caution:

- Be sure to use new self-locking nuts and new flange bolts.
- Check if the collar is protruding from the rear axle housing.
- Do not apply grease, etc. to the ball stud shaft portion.
- Be careful not to damage the boot of the ball joint.
- The flange bolt length differs between MT model and CVT model. Confirm the part number before installation.

3. Temporarily install the stabilizer link rear to the rear lateral link assembly rear.

Caution:

Always use a new flange nut.

4. Temporarily install the shock absorber assembly rear to the rear lateral link assembly rear.

Caution:

Be sure to use a new self-locking nut.

5. Temporarily install the rear axle housing to the rear lateral link assembly rear.

Caution:

Be sure to use a new self-locking nut.

6. Temporarily install the rear axle housing to the trailing link assembly rear.

Caution:

Be sure to use new self-locking nuts and new flange bolts.

7. Tighten the self-locking nut securing the rear axle housing to the arm assembly rear upper.

Tightening torque:

80 N·m (8.2 kgf-m, 59.0 ft-lb)

8. Connect the rear lateral link assembly front to the rear axle housing.

(1) Connect the rear lateral link assembly front to the rear axle housing.

Caution:

- Do not apply grease, etc. to the tapered portion of ball joint.
- Be careful not to damage the boot of the ball joint.

Tightening torque:

60 N·m (6.1 kgf-m, 44.3 ft-lb)

(2) Install a new snap pin.

9. Apply a load to the rear axle housing using a transmission jack.

Note:

- **Set a wooden block, etc. on the contact surface between the transmission jack and housing.**
- **Confirm that the vehicle is in empty condition (at curb weight).**

10. Tighten the bolt securing the rear axle housing to the trailing link assembly rear.

Tightening torque:

100 N·m (10.2 kgf-m, 73.8 ft-lb)

11. Tighten the flange nut securing the stabilizer link rear to the rear lateral link assembly rear.

Tightening torque:

38 N·m (3.9 kgf-m, 28.0 ft-lb)

12. Tighten the self-locking nut securing the shock absorber assembly rear to the rear lateral link assembly rear.

Tightening torque:

85 N·m (8.7 kgf-m, 62.7 ft-lb)

13. Tighten the self-locking nut securing the rear lateral link assembly rear to the rear axle housing.

Tightening torque:

82.5 N·m (8.4 kgf-m, 60.8 ft-lb)

14. Remove the transmission jack.

15. Install the clamp hand brake cable, and connect the cable assembly hand brake. (MT model)

16. Connect the bracket. (MT model)

Tightening torque:

18 N·m (1.8 kgf-m, 13.3 ft-lb)

17. Install the parking brake assembly. (MT model) [Ref. to PARKING BRAKE>Parking Brake Assembly \(Rear Disc Brake\)>INSTALLATION > EXCEPT FOR THE ELECTRONIC PARKING BRAKE MODEL.](#)

18. Connect the adapter cord EPB bracket. (CVT model)

Tightening torque:

18 N·m (1.8 kgf-m, 13.3 ft-lb)

19. Install the rear disc rotor. (CVT model) [Ref. to BRAKE>Rear Disc Rotor>INSTALLATION.](#)

20. Install the sensor sub assembly rear.

Tightening torque:

7.5 N·m (0.8 kgf-m, 5.5 ft-lb)

21. While depressing the brake pedal, install the axle nut.

Caution:

Be sure to use a new axle nut.

Tightening torque:

190 N·m (19.4 kgf-m, 140.1 ft-lb)

22. Crimp the axle nut.

23. Install the rear wheels. [Ref. to WHEEL AND TIRE SYSTEM>Tire and Wheel>INSTALLATION.](#)

24. Release the shift lock and shift the select lever to the "P range". (CVT model) [Ref. to CONTROL SYSTEMS>Select Lever>INSTALLATION.](#)

25. Connect the ground terminal to battery sensor. [Ref. to REPAIR CONTENTS>NOTE > BATTERY.](#)

26. Exit the brake maintenance mode. (CVT model) [Ref. to PARKING BRAKE>Parking Brake System>OPERATION > BRAKE MAINTENANCE MODE.](#)

27. After the operation is completed, apply and release the parking brake five times and ensure that the brake operates normally.

28. Inspect the wheel alignment and adjust if necessary. [Ref. to FRONT SUSPENSION>Wheel Alignment>INSPECTION.](#)

29. Perform VDC sensor midpoint setting mode. [Ref. to VEHICLE DYNAMICS CONTROL \(VDC\)>VDC Control Module and Hydraulic Control Unit \(VDCM&H/U\)>ADJUSTMENT > VDC SENSOR MIDPOINT SETTING MODE.](#)

30. Perform the lane keep assist learning value clear. (Models with EyeSight) [Ref. to EyeSight \(DIAGNOSTICS\)>Work Support.](#)

PROPELLER SHAFT / DRIVE SHAFT / AXLE > Rear Axle

DISASSEMBLY

Note:

For CVT model, parts cannot be disassembled.

If disassembled, replace the rear axle housing with a new part.

1. Pull out the rubber bushing trailing link (A) using ST1, ST2 and a press.

Note:

- **ST1 and ST2 have different orientations for pull-out and press-fit.**
- **Pillow ball bushing (a) cannot be disassembled.**

Preparation tool:

ST1: BUSHING REMOVER (20099FG000)
ST2: INSTALLER & REMOVER (20099PA010)

PROPELLER SHAFT / DRIVE SHAFT / AXLE > Rear Axle

ASSEMBLY

1. Press-fit the rubber bushing trailing link (A) using ST1, ST2 and a press.

Caution:

Hold the bushing so that it is not tilted.

Note:

ST1 and ST2 have different orientations for pull-out and press-fit.

Preparation tool:

ST1: BUSHING REMOVER (20099FG000)
ST2: INSTALLER & REMOVER (20099PA010)

PROPELLER SHAFT / DRIVE SHAFT / AXLE > Rear Axle

INSPECTION

1. Check that there is no deformation, cracks or other damages.
2. Check for excessive rusting.
3. Check the bushing for crack or excessive hardening.
4. Check the pillow ball bushing for looseness.

PROPELLER SHAFT / DRIVE SHAFT / AXLE > Rear Hub Unit Bearing

REMOVAL



Caution:

Do not loosen the axle nut while the rear axle is loaded.

1. Release the parking brake.
2. Execute the brake maintenance mode. (CVT model) [Ref. to PARKING BRAKE>Parking Brake System>OPERATION > BRAKE MAINTENANCE MODE.](#)
3. Release the shift lock and shift the select lever to the "N range". (CVT model) [Ref. to CONTROL SYSTEMS>Select Lever>REMOVAL.](#)
4. Disconnect the ground terminal from battery sensor. [Ref. to REPAIR CONTENTS>NOTE > BATTERY.](#)
5. Remove the rear wheels. [Ref. to WHEEL AND TIRE SYSTEM>Tire and Wheel>REMOVAL.](#)
6. Lift the crimped section of axle nut.

7. Remove the axle nut while depressing the brake pedal.
8. Remove the parking brake assembly. (MT model) [Ref. to PARKING BRAKE>Parking Brake Assembly \(Rear Disc Brake\)>REMOVAL > EXCEPT FOR THE ELECTRONIC PARKING BRAKE MODEL.](#)
9. Disconnect the bracket. (MT model)

10. Remove the clamp hand brake cable, and disconnect the cable assembly hand brake. (MT model)

11. Remove the rear disc rotor. (CVT model) [Ref. to BRAKE>Rear Disc Rotor>REMOVAL.](#)

12. Disconnect the adapter cord EPB bracket. (CVT model)

13. Remove the rear hub unit bearing and rear brake back plate.

Caution:

- **Be careful not to damage the rear hub unit bearing.**
- **Do not get closer the tool which charged magnetism to the rear hub unit bearing.**

Note:

If it is hard to remove, use ST1 and ST2.

Preparation tool:

ST1: AXLE SHAFT PULLER (926470000)

ST2: AXLE SHAFT PULLER PLATE (28099PA110)

PROPELLER SHAFT / DRIVE SHAFT / AXLE > Rear Hub Unit Bearing

INSTALLATION

1. Install the rear brake back plate and rear hub unit bearing.

Caution:

- Always use a new bolt.
- Be careful not to damage the spline portion of the rear drive shaft.
- Be careful not to damage the rear hub unit bearing.
- Do not get closer the tool which charged magnetism to the rear hub unit bearing.

Tightening torque:

85 N·m (8.7 kgf-m, 62.7 ft-lb)

2. Install the clamp hand brake cable, and connect the cable assembly hand brake. (MT model)
3. Connect the bracket.

Tightening torque:

18 N·m (1.8 kgf-m, 13.3 ft-lb)

4. Install the parking brake assembly. (MT model) [Ref. to PARKING BRAKE>Parking Brake Assembly \(Rear Disc Brake\)>INSTALLATION > EXCEPT FOR THE ELECTRONIC PARKING BRAKE MODEL.](#)
5. Connect the adapter cord EPB bracket. (CVT model)

Tightening torque:

18 N·m (1.8 kgf-m, 13.3 ft-lb)

6. Install the rear disc rotor. (CVT model) [Ref. to BRAKE>Rear Disc Rotor>INSTALLATION.](#)
7. While depressing the brake pedal, install the axle nut.

Caution:

- Be sure to use a new axle nut.

Tightening torque:

190 N·m (19.4 kgf-m, 140.1 ft-lb)

8. Crimp the axle nut.

9. Install the rear wheels. [Ref. to WHEEL AND TIRE SYSTEM>Tire and Wheel>INSTALLATION.](#)
10. Release the shift lock and shift the select lever to the "P range". (CVT model) [Ref. to CONTROL SYSTEMS>Select Lever>INSTALLATION.](#)
11. Connect the ground terminal to battery sensor. [Ref. to REPAIR CONTENTS>NOTE > BATTERY.](#)
12. Exit the brake maintenance mode. (CVT model) [Ref. to PARKING BRAKE>Parking Brake System>OPERATION > BRAKE MAINTENANCE MODE.](#)
13. After the operation is completed, apply and release the parking brake five times and ensure that the brake operates normally.
14. Apply the parking brake.

PROPELLER SHAFT / DRIVE SHAFT / AXLE > Rear Hub Unit Bearing

DISASSEMBLY



Using the ST and a press, push out the hub bolt (B) from the rear hub unit bearing (A).

Caution:

Be careful not to tap the hub bolts with a hammer, etc. This may deform the rear hub unit bearing.

Note:

Rear hub unit bearing cannot be disassembled.

Preparation tool:

ST: HUB STAND (28399AG000)

PROPELLER SHAFT / DRIVE SHAFT / AXLE > Rear Hub Unit Bearing

ASSEMBLY

1. Set the rear hub unit bearing and hub bolt to the ST.

Caution:

Always use a new hub bolt.

Preparation tool:

ST: HUB STAND (28099PA080)

2. Using a press, press-fit the hub bolt (B) until its seating surface contacts the rear hub unit bearing (A).

Note:

Use the 12 mm (0.5 in) dia. holes of ST to prevent bolts from tilting.

PROPELLER SHAFT / DRIVE SHAFT / AXLE > Rear Hub Unit Bearing

INSPECTION

1. Check that there is no deformation, cracks or other damages.
2. Check for excessive rusting.
3. Check the following items by turning the rear tires by hand.
 - Check for smooth rotation.
 - Check for noise.
4. Check the rear hub unit bearing for looseness.
 - (1) Rock the rear tire as shown in the figure.
 - Looseness exists → Go to next step.
 - No looseness → Normal (Perform step 5 if precise inspection is required.)

(2) Check the play with the brake pedal depressed using the same procedure as step (1).

- Looseness exists → Check the ball joint, each bushing, rear suspension and rear axle housing.
 - No looseness → Replace the rear hub unit bearing.
5. To perform a precise inspection, use a magnet stand and dial gauge to check for looseness in the axial direction of the rear hub unit bearing.

Service limit:

0.05 mm (0.002 in)

PROPELLER SHAFT / DRIVE SHAFT / AXLE > Symptoms and causes

INSPECTION

Caution:

If noise occurs, identify the cause before work.

Symptoms	Problem parts etc.	Possible cause
Booming noise or vibration occurs at a specific vehicle speed.	Propeller shaft	Unbalanced propeller shaft
		Deformation, damage or excessive hardening of bushing
	Companion flange of rear differential	Looseness at joint section
Continuous noise during driving (frequency is proportional to vehicle speed)	Hub unit bearing	Defective hub unit bearing
	Propeller shaft	Defective center bearing
Noise when turning	Drive shaft	Defective joint section