


FUEL INJECTION (FUEL SYSTEMS)(H4DOTC)

FU(H4DOTC)

1. General Description
2. Throttle Body
3. Intake Manifold Assembly
4. Tumble Generator Valve
5. Tumble Generator Valve Actuator
6. Fuel Insulator
7. Fuel Injector
8. Fuel Pressure Sensor
9. High Pressure Fuel Pump
10. High Pressure Fuel Delivery Pipe
11. Engine Wiring Harness
12. Engine Coolant Temperature Sensor
13. Engine Oil Temperature Sensor
14. Crankshaft Position Sensor
15. Crankshaft Position Sensor Plate
16. Camshaft Position Sensor
17. Oil Control Solenoid
18. Knock Sensor
19. Throttle Position Sensor
20. Mass Air Flow and Intake Air Temperature Sensor
21. Manifold Absolute Pressure and Intake Air Temperature Sensor
22. CPC Pressure Sensor
23. Front Oxygen (A/F) Sensor
24. Rear Oxygen Sensor
25. SI-DRIVE (SUBARU Intelligent Drive) Selector
26. Engine Control Module (ECM)
27. Main Relay
28. Electronic Throttle Control Relay
29. Fuel Pump Relay
30. Fuel Pump Control Unit
31. Fuel
32. Fuel Tank Protector
33. Fuel Tank
34. Fuel Filler Cap
35. Fuel Filler Pipe
36. Fuel Pump Assembly
37. Fuel Level Sensor
38. Fuel Sub Level Sensor
39. Fuel Filter
40. Fuel Delivery and Evaporation Lines
41. Symptoms and causes

FUEL INJECTION (FUEL SYSTEMS)(H4DOTC) > General Description

CAUTION

- When performing service operation, refer to "Repair Contents" in "General Description".  [Ref. to REPAIR CONTENTS>Repair Contents.](#)
- Prior to starting work, pay special attention to the following:
 1. Always wear work clothes, a work cap, and protective shoes. Additionally, wear a helmet, protective goggles, etc. if necessary.
 2. Protect the vehicle using a seat cover, fender cover, etc.
 3. Prepare the service tools, clean cloth, containers to catch grease and oil, etc.
- Prevent scattering of grease and oil. If it scatters, wipe it off immediately to prevent it from penetrating the floor or flowing out, to protect the environmental.
- If the grease and oil is spilt over the engine, exhaust pipe or the under cover, completely wipe it off to avoid emission of smoke or causing a fire.
- Vehicle components are extremely hot immediately after driving. Be wary of receiving burns from heated parts.
- When performing a repair, identify the cause of trouble and avoid unnecessary work.
- Before disconnecting connectors of sensors or units, be sure to disconnect the ground terminal from the battery sensor.
- Always use the jack-up point when the lifting device, shop jacks or rigid racks are used to support the vehicle.
- Before starting works, remove dirt and corrosion around the target area.
- Keep the removed parts in order and protect them from dust and dirt.
- All removed parts, if to be reused, should be reinstalled in the original positions with attention to the correct directions, etc.
- For the parts except for the non-reusable parts, replace them with new parts if necessary.
- Be sure to tighten bolts and nuts to the specified torque.
- Always use new application oil during work.
- When working on the fuel lines, place "NO OPEN FLAMES" signs near the working area.
- Always ventilate sufficiently when working on the fuel lines.
- Always inspect for fuel leaks after working on the fuel lines is completed.
- Follow all government and local regulations concerning disposal of refuse when disposing fuel.

FUEL INJECTION (FUEL SYSTEMS)(H4DOTC) > General Description

SPECIFICATION

1. FUEL TANK

Capacity	63 L (16.6 US gal, 13.9 Imp gal)
Location	Under rear seat

2. FUEL PUMP

Type	Impeller
Shutoff discharge pressure	1140 kPa (11.6 kg/cm ² , 165.3 psi) or less (12.5 V)
Discharge rate	153 L (40.4 US gal, 33.7 Imp gal)/h or more [12.5 V at 343 kPa (3.5 kg/cm ² , 49.7 psi)]

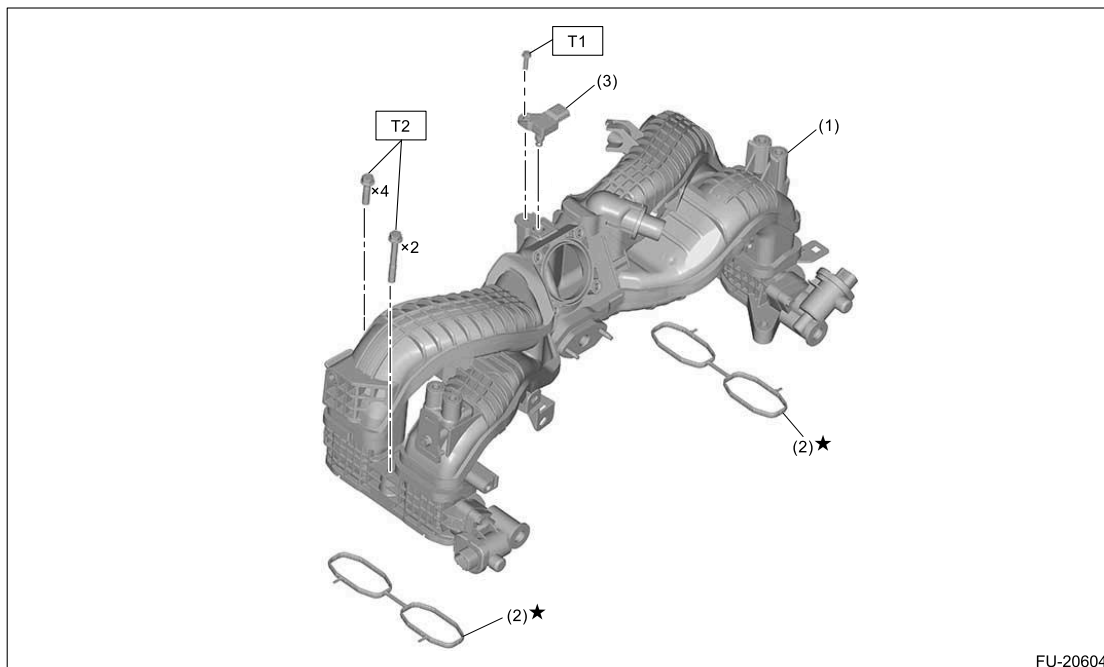
3. FUEL FILTER

Fuel filter	In-tank type
-------------	--------------

FUEL INJECTION (FUEL SYSTEMS)(H4DOTC) > General Description

COMPONENT

1. INTAKE MANIFOLD ASSEMBLY



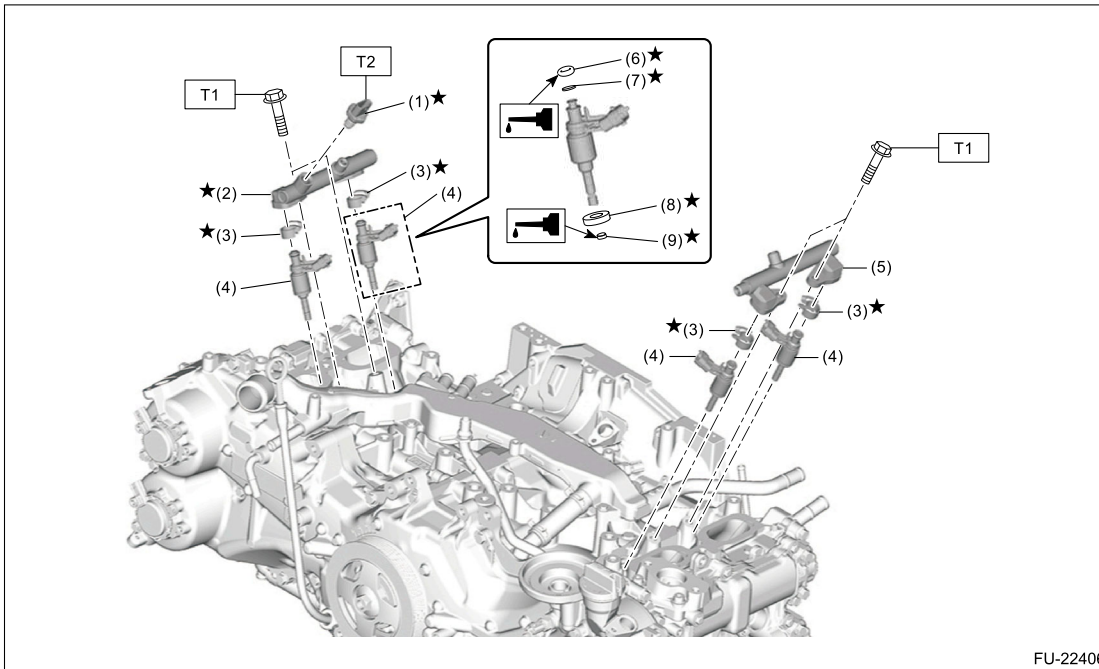
- (1) Intake manifold ASSY
- (2) Gasket
- (3) Manifold absolute pressure and intake air temperature sensor

Tightening torque: N·m (kgf·m, ft·lb)

T1: 3.4 (0.3, 2.5)

T2: 25 (2.5, 18.4)

2. FUEL INJECTOR



FU-22406

- (1) Fuel pressure sensor
- ★(2) Fuel injector pipe RH*
- ★(3) Holder
- (4) Fuel injector ASSY
- (5) Fuel injector pipe LH

- (6) O-ring
- (7) Support disc
- (8) Decoupling
- (9) Fuel injector seal

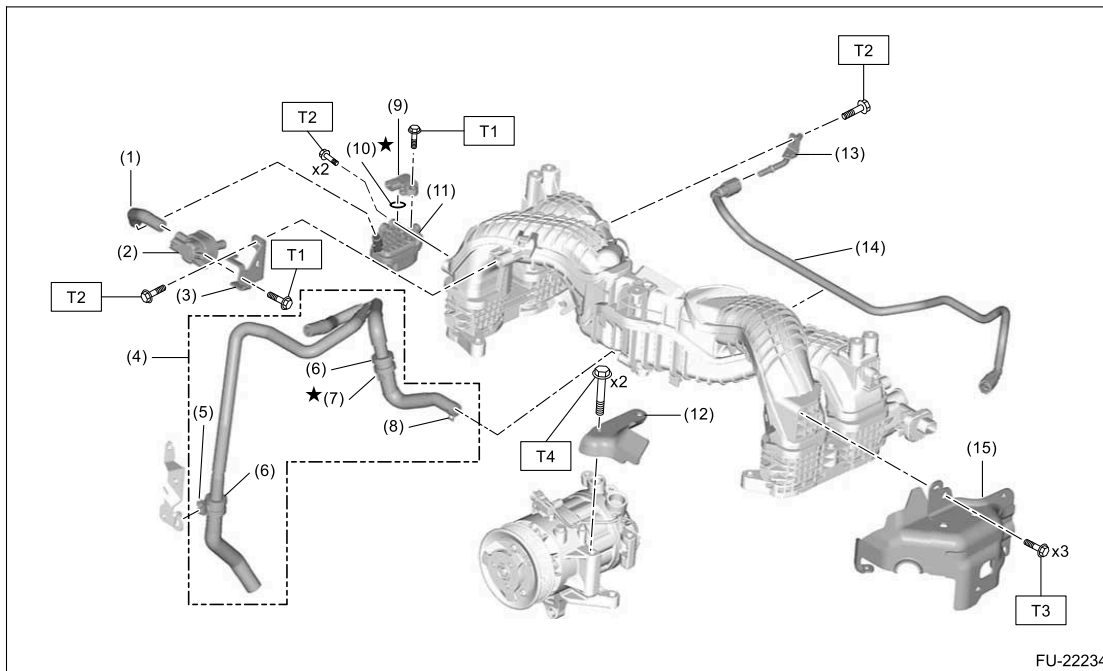
Tightening torque: N·m (kgf-m, ft-lb)

T1: 19 (1.9, 14.0)

T2: 46 (4.7, 33.9)

*: When removing the fuel pressure sensor from the fuel injector pipe RH, replace it with a new one.

3. FUEL PIPE 1



FU-22234

- | | |
|--|--------------------------------|
| (1) Vacuum hose | (9) CPC pressure sensor |
| (2) Purge control solenoid valve | (10) O-ring |
| (3) Purge control solenoid valve bracket | (11) Vacuum pipe ASSY |
| (4) Vacuum hose ASSY | (12) Fuel pipe protector No. 1 |
| (5) Band clip | (13) Fuel pipe |
| (6) Check valve | (14) Fuel delivery pipe |
| (7) Clamp | (15) Fuel pipe protector No. 2 |
| (8) Clip | |

Tightening torque: N·m (kgf·m, ft·lb)

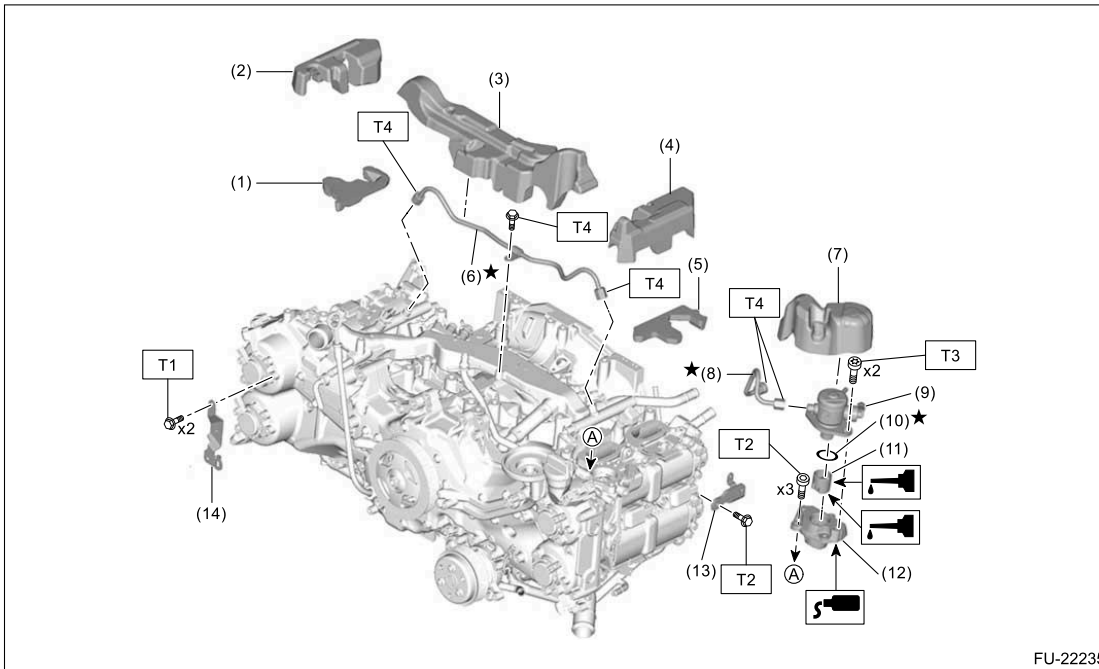
T1: 3.4 (0.3, 2.5)

T2: 6.4 (0.7, 4.7)

T3: 19 (1.9, 14.0)

T4: 25 (2.5, 18.4)

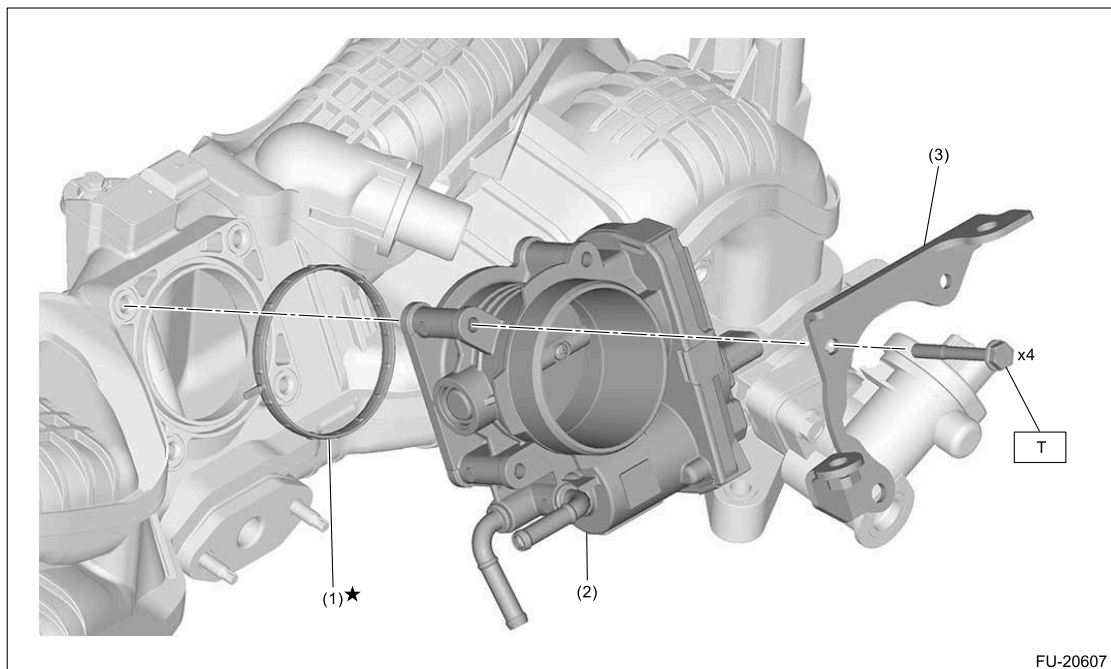
4. FUEL PIPE 2



FU-22235

- | | | |
|---|--------------------------------------|--|
| (1) Fuel pipe insulator No. 1 | (8) High-pressure fuel delivery pipe | Tightening torque: N·m (kgf-m, ft-lb) |
| (2) Fuel pipe insulator No. 2 | (9) High-pressure fuel pump | T1: 6.4 (0.7, 4.7) |
| (3) Fuel pipe insulator No. 3 | (10) O-ring | T2: 19 (1.9, 14.0) |
| (4) Fuel pipe insulator No. 4 | (11) Fuel pump lifter | T3: 21 (2.1, 15.5) |
| (5) Fuel pipe insulator No. 5 | (12) High-pressure fuel pump case | T4: Ref. to FUEL INJECTION (FUEL SYSTEMS)(H4DOTC)>High Pressure Fuel Delivery Pipe>INSTALLATION. |
| (6) High-pressure fuel delivery pipe ASSY | (13) Protector stay | |
| (7) Fuel pump insulator | (14) Vacuum hose stay | |

5. THROTTLE BODY



(1) Gasket

(3) Throttle body stay

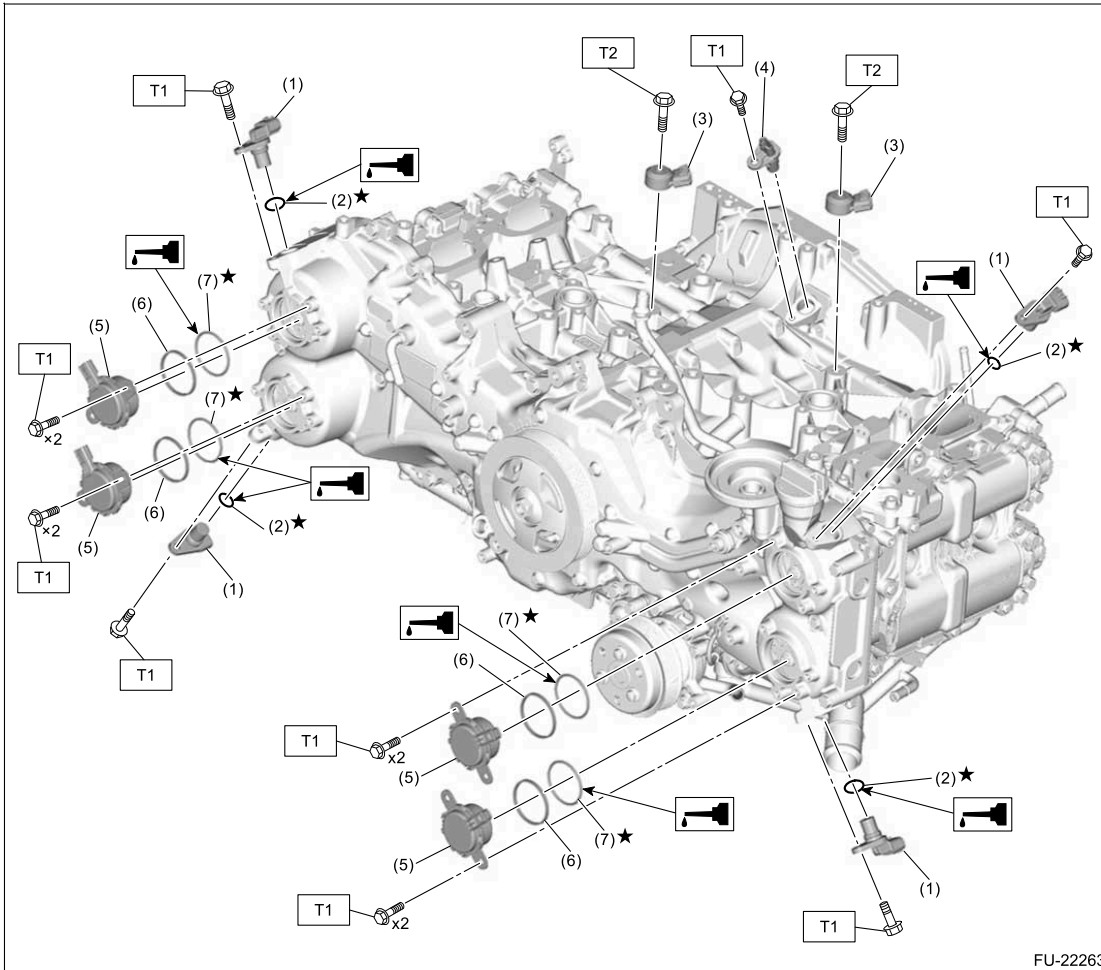
**Tightening torque: N·m (kgf·m,
ft·lb)**

(2) Throttle body

T: 8 (0.8, 5.9)

6. CRANKSHAFT POSITION SENSOR, CAMSHAFT POSITION SENSOR, KNOCK SENSOR AND OIL

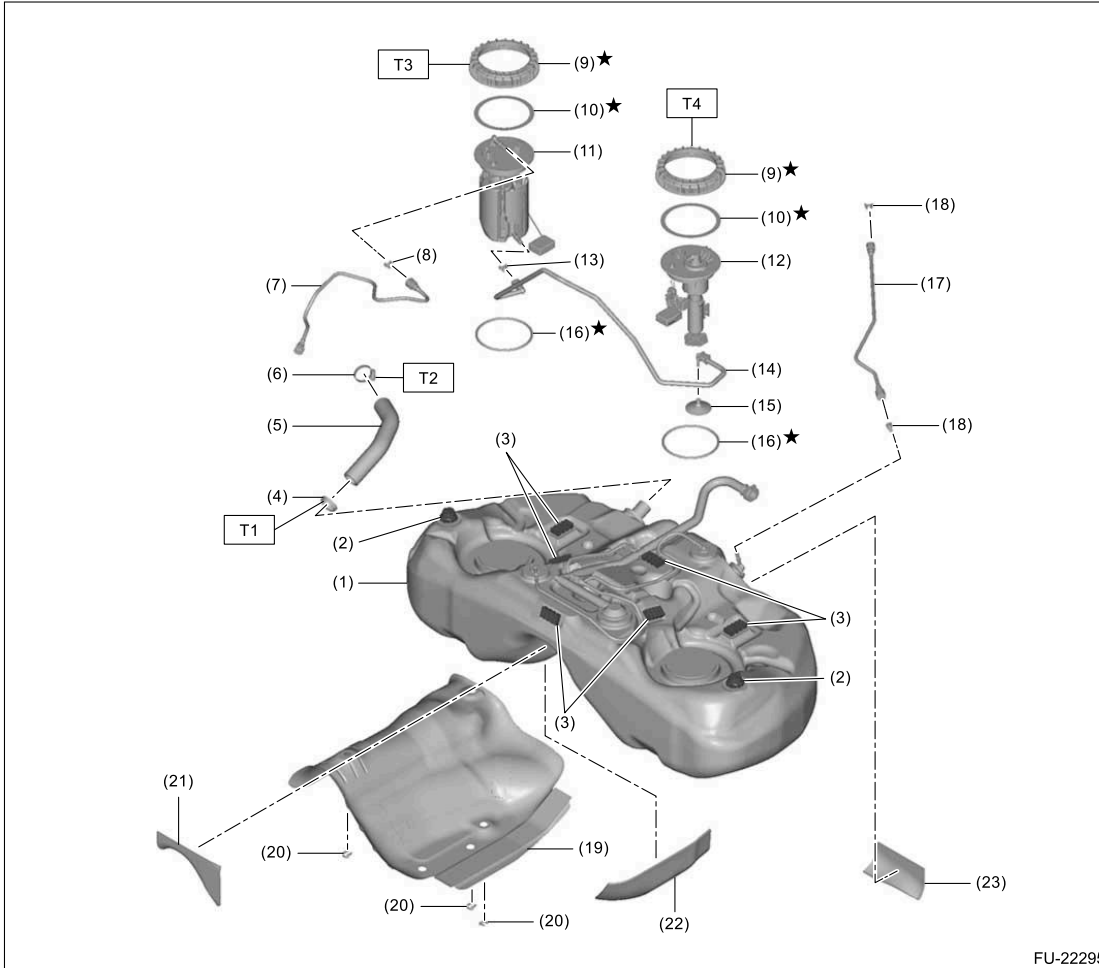
CONTROL SOLENOID



- (1) Camshaft position sensor
- (2) O-ring
- (3) Knock sensor
- (4) Crankshaft position sensor
- (5) Oil control solenoid
- (6) Back-up ring
- (7) O-ring

Tightening torque: N·m (kgf·m, ft·lb)
T1: 6.4 (0.7, 4.7)
T2: 24 (2.4, 17.7)

7. FUEL TANK 1



FU-22295

- | | | |
|------------------------|-----------------------------|------------------------|
| (1) Fuel tank | (11) Fuel pump ASSY | (21) Tank sheet No. 1* |
| (2) Cushion ASSY | (12) Fuel sub level sensor | (22) Tank sheet No. 2* |
| (3) Cushion* | (13) Retainer | (23) Tank sheet No. 3* |
| (4) Clamp | (14) Fuel sub delivery tube | |
| (5) Fuel filler hose | (15) Filter | |
| (6) Clamp | (16) Gasket | |
| (7) Fuel delivery tube | (17) Circulate tube | |
| (8) Retainer | (18) Retainer | |
| (9) Ring nut | (19) Fuel tank cover | |
| (10) Ring nut plate | (20) Cover clamp | |

*: When removing from the fuel tank, replace it with a new part.

Tightening torque: N·m (kgf-m, ft-lb)

T1: 2 (0.2, 1.5)

T2: 5 (0.5, 3.7)

T3:  Ref. to FUEL

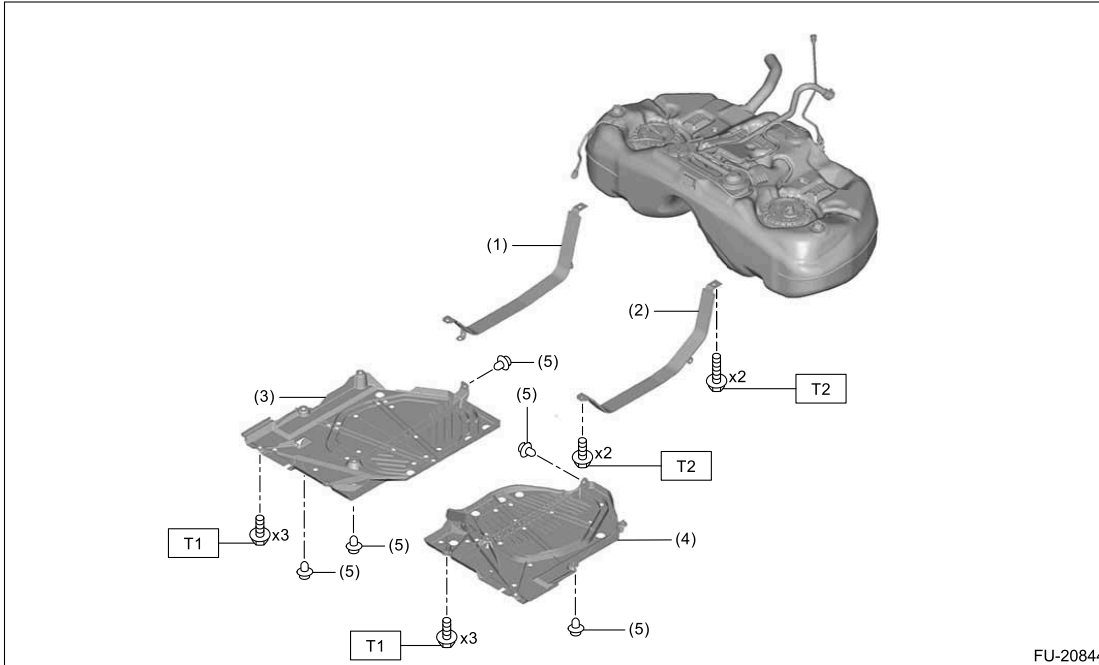
INJECTION (FUEL SYSTEMS)(H4DOTC)>Fuel Pump

Assembly>INSTALLATION.

T4:  Ref. to FUEL

INJECTION (FUEL SYSTEMS)(H4DOTC)>Fuel Sub Level Sensor>INSTALLATION.

8. FUEL TANK 2



FU-20844

- (1) Fuel tank band RH
- (2) Fuel tank band LH
- (3) Fuel tank protector RH

- (4) Fuel tank protector LH
- (5) Clip

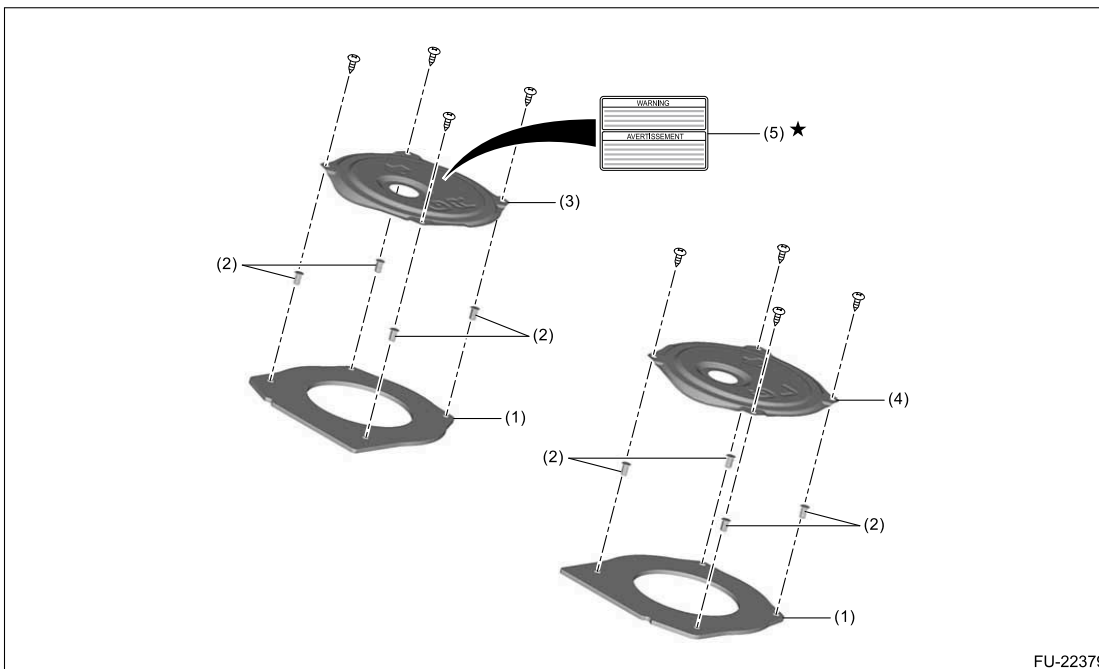
Tightening torque: N·m (kgf-m, ft-lb)

T1: 18 (1.8, 13.3)

T2:  Ref. to FUEL

INJECTION (FUEL SYSTEMS)(H4DOTC)>Fuel Tank>INSTALLATION.

9. FUEL TANK 3



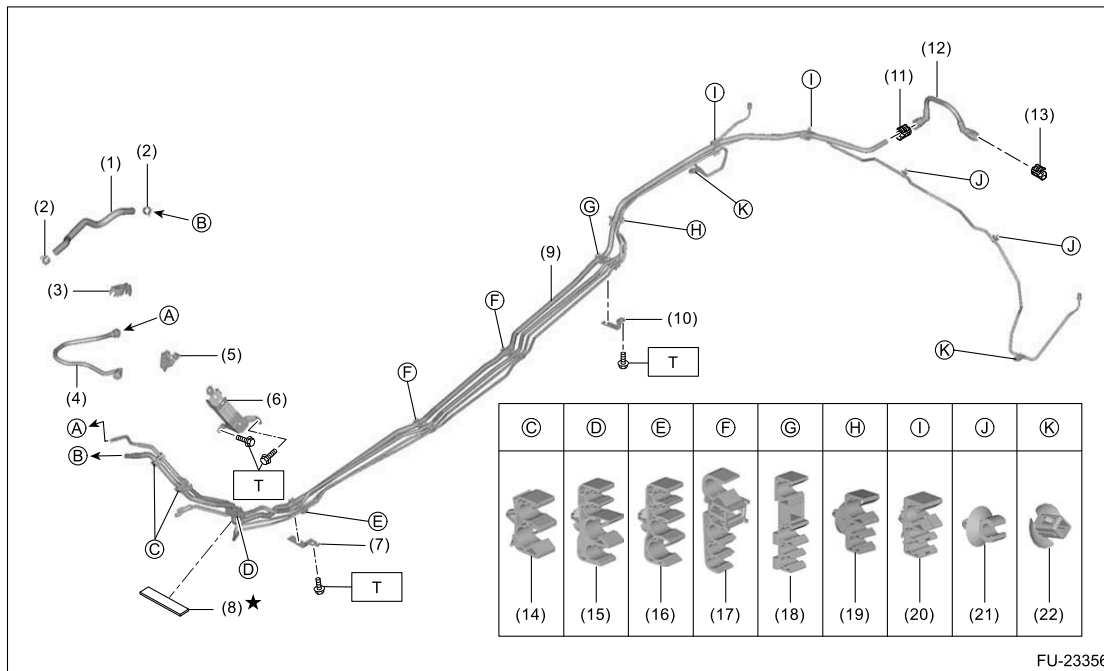
FU-22379

- (1) Gasket
- (2) Grommet

- (3) Service hole cover RH
- (4) Service hole cover LH

- (5) Label

10. FUEL LINE 1



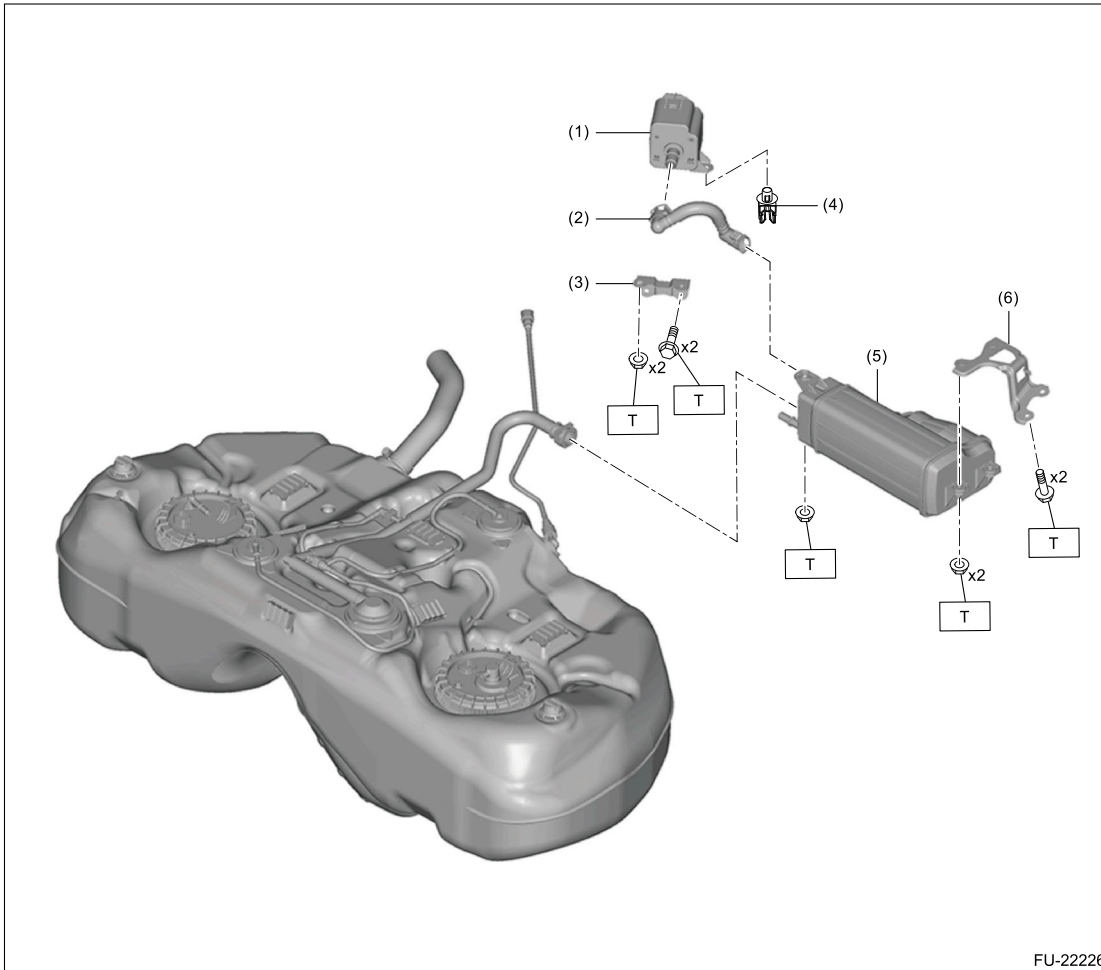
FU-23356

- | | | |
|------------------------------|--------------------------|-----------------|
| (1) Evaporation hose | (9) Fuel pipe ASSY | (17) Pipe clamp |
| (2) Clip | (10) Fuel pipe bracket C | (18) Pipe clamp |
| (3) Fuel delivery tube clamp | (11) Retainer | (19) Pipe clamp |
| (4) Fuel delivery tube | (12) Purge tube | (20) Pipe clamp |
| (5) Fuel delivery tube clamp | (13) Retainer | (21) Pipe clamp |
| (6) Fuel pipe bracket A | (14) Pipe clamp | (22) Pipe clamp |
| (7) Fuel pipe bracket B | (15) Pipe clamp | |
| (8) Cushion | (16) Pipe clamp | |

Tightening torque: N·m (kgf·m, ft·lb)

T: 18 (1.8, 13.3)

11. FUEL LINE 2



FU-22226

(1) Leak check valve ASSY

(4) Tube clamp

**Tightening torque: N·m (kgf·m,
ft·lb)**

(2) Drain tube

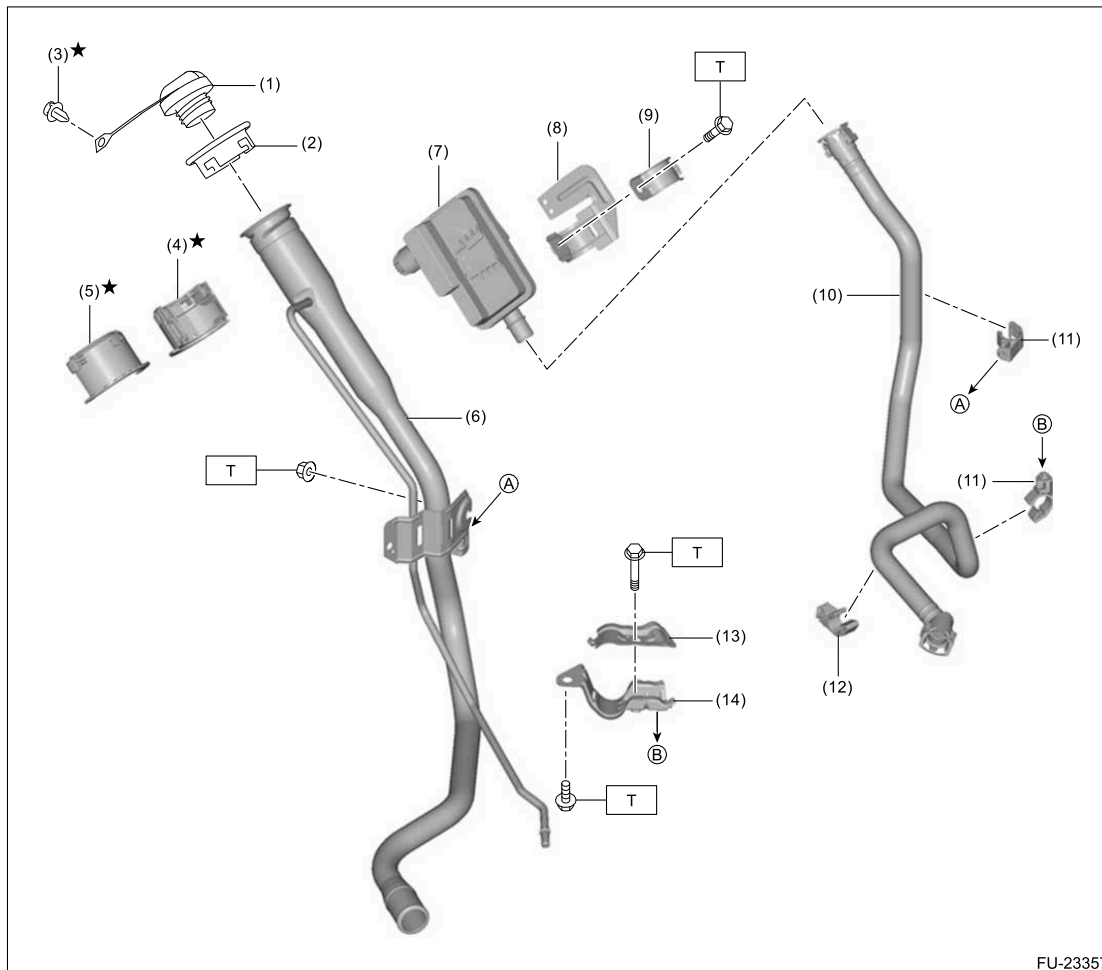
(5) Canister

T: 8 (0.8, 5.9)

(3) Leak check valve ASSY
bracket

(6) Canister bracket

12. FUEL FILLER PIPE



FU-23357


- | | | |
|--------------------------------|-----------------------------|--------------------|
| (1) Fuel filler cap | (7) Drain filter ASSY* | (13) Upper bracket |
| (2) Fuel filler pipe protector | (8) Drain filter bracket A* | (14) Lower bracket |
| (3) Clip | (9) Drain filter bracket B | |
| (4) Neck holder A | (10) Drain tube | |
| (5) Neck holder B | (11) Tube clamp | |
| (6) Fuel filler pipe | (12) Tube clamp | |

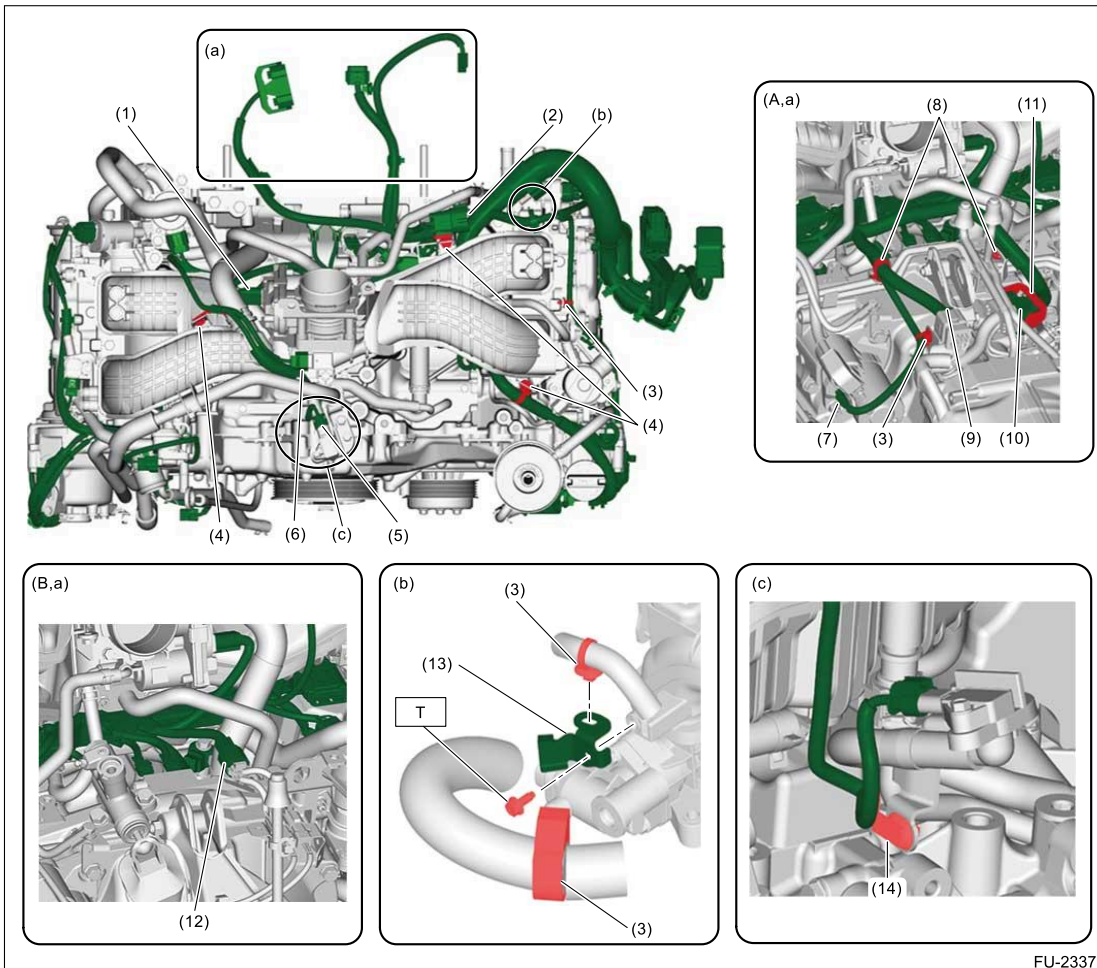
Tightening torque: N·m (kgf-m, ft-lb)

T: 7.5 (0.8, 5.5)

*: If the drain filter bracket A is removed from the drain filter, be sure to replace the drain filter and drain filter bracket A with new parts.

13. FUEL LID

For the fuel lid components, refer to the "SECURITY AND LOCKS".  [Ref. to SECURITY AND LOCKS>General Description>COMPONENT.](#)



FU-23371

(A) CVT model

(B) MT model

(1) Throttle position sensor connector

(2) 11P connector

(3) Secure the clip to the stay.

(4) Secure a clip to the intake manifold.

(5) Pressure sensor connector

(6) Manifold pressure and intake air temperature sensor connector

(7) Starter magnet switch

(8) Secure to the CVT pipe stay.

(9) CVT transmission harness connector (20P)

(10) CVT transmission harness connector (30P)

(11) Lock the lever firmly.

(12) MT transmission harness connector

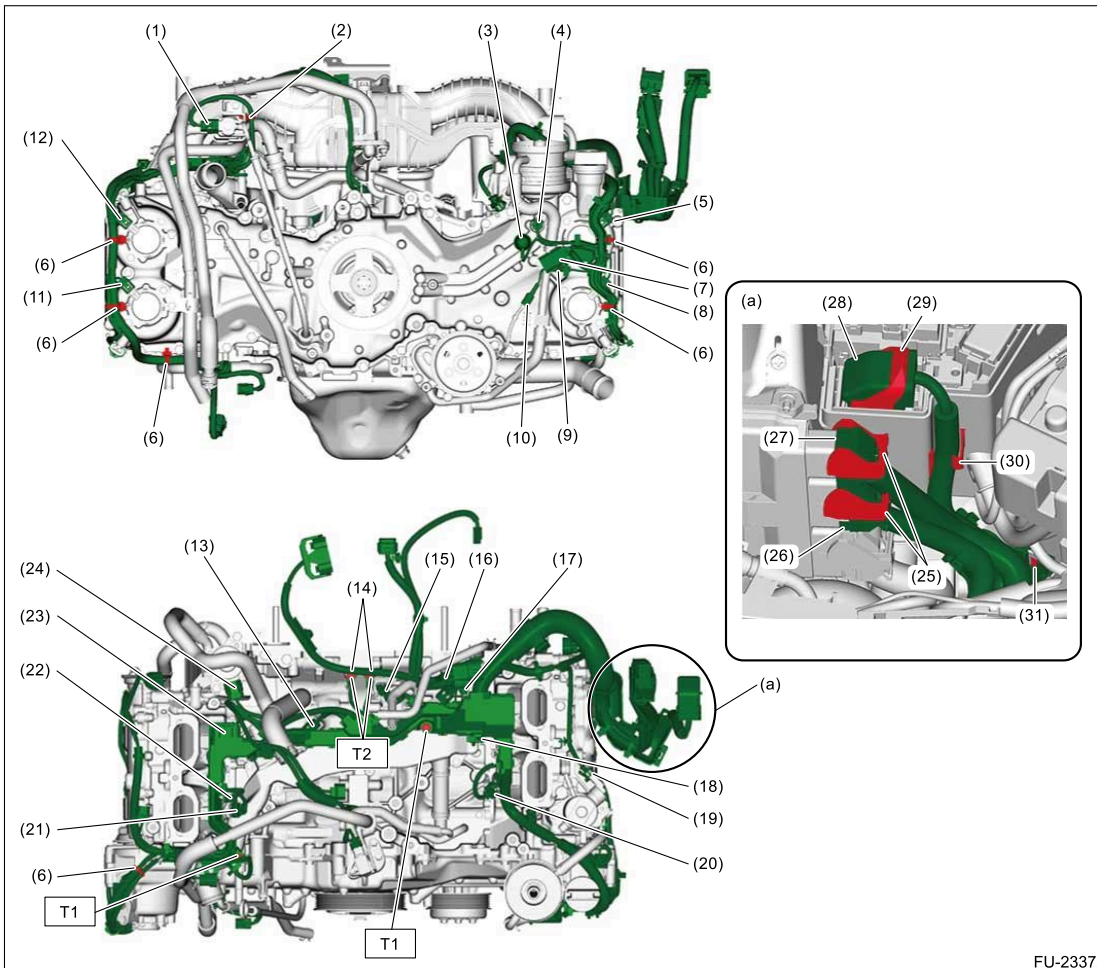
(13) Harness stay

(14) Secure the clip.


Tightening torque: N·m (kgf·m, ft·lb)

T: 6.4 (0.7, 4.7)

- Structural diagram 2



FU-23372

- (1) Purge control solenoid valve connector
- (2) Secure the clip to the purge control solenoid valve bracket.
- (3) Oil pressure switch (Refer to "Oil Pressure Switch" of "LUBRICATION" for installation.  [Ref. to LUBRICATION\(H4DOTC\)>Oil Pressure Switch>INSTALLATION.](#))
- (4) Engine oil temperature sensor connector
- (5) Intake oil control solenoid connector LH
- (6) Secure the clip to the screw hole.
- (7) Front oxygen (A/F) sensor connector
- (8) Exhaust oil control solenoid connector LH
- (9) Secure the clip to the oil cooler pipe.
- (10) Oil level switch connector
- (11) Exhaust oil control solenoid connector RH
- (12) Intake oil control solenoid connector RH
- (13) Knock sensor connector RH
- (14) Engine ground
- (15) Crankshaft position sensor connector
- (16) Knock sensor connector LH
- (17) Engine coolant temperature sensor connector
- (18) Fuel injector connector (#4)
- (19) High-pressure fuel pump connector
- (20) Fuel injector connector (#2)
- (21) Fuel pressure sensor connector
- (22) Fuel injector connector (#1)
- (23) Fuel injector connector (#3)

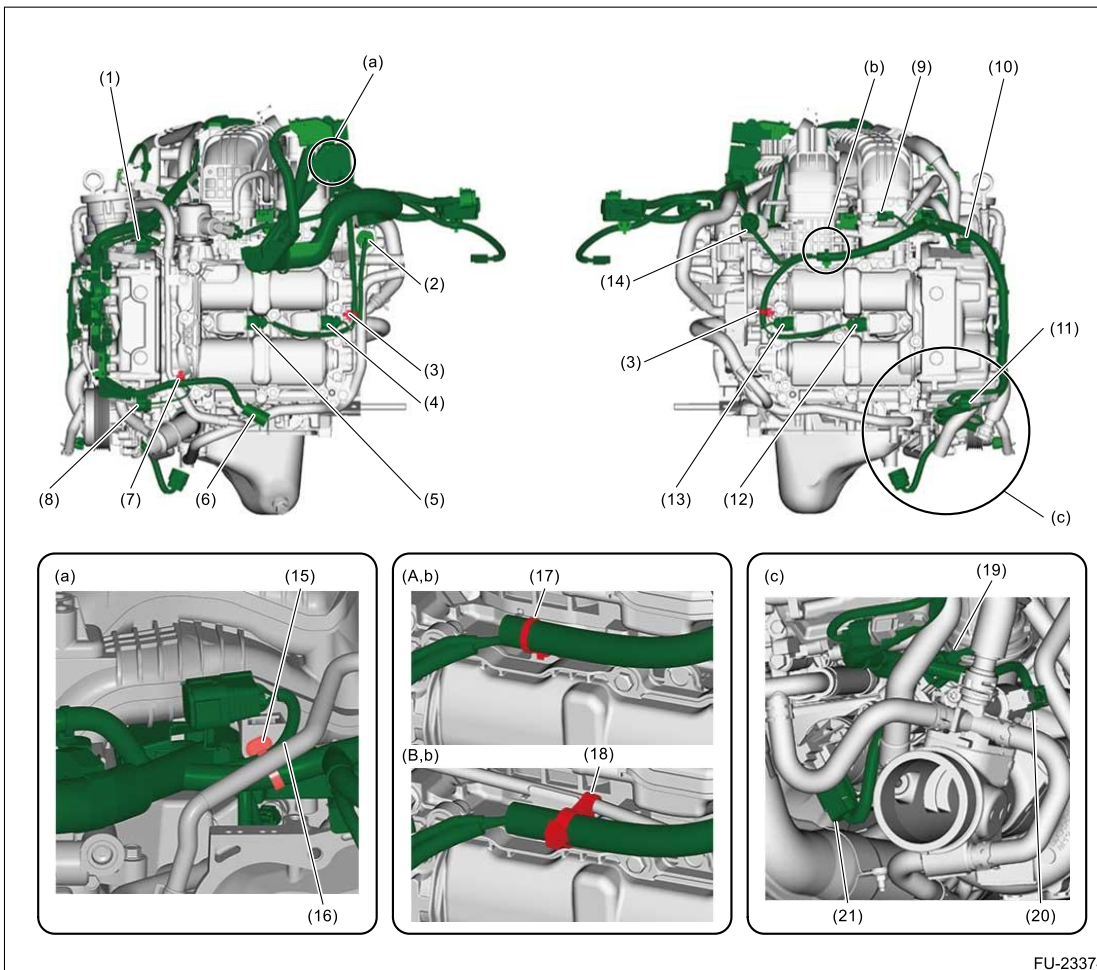
- (24) EGR control valve connector
- (25) Lock the lever firmly.
- (26) ECM connector (64P)
- (27) ECM connector (32P)
- (28) M/B connector (76P)
- (29) Push in the lock lever securely.
- (30) Secure the harness to the clip.
- (31) Secure to the harness stay.

Tightening torque: N·m (kgf·m, ft·lb)

T1: 6.4 (0.7, 4.7)

T2: 19 (1.9, 14.0)

- Structural diagram 3



FU-23374

- (A) CVT model
- (B) MT model
- (1) Intake camshaft position sensor connector LH
- (2) Tumble generator valve actuator connector LH
- (3) Secure the clip to the screw hole.
- (4) Ignition coil connector (#4)
- (5) Ignition coil connector (#2)
- (6) Rear oxygen sensor connector
- (7) Secure the clip to the stay.
- (8) Exhaust camshaft position sensor connector LH
- (9) CPC pressure sensor connector

- (10) Intake camshaft position sensor connector RH
- (11) Exhaust camshaft position sensor connector RH
- (12) Ignition coil connector (#1)
- (13) Ignition coil connector (#3)
- (14) Tumble generator valve actuator connector RH
- (15) Secure a clip to the intake manifold.
- (16) Route the harness between the preheater hose and the intake manifold.
- (17) Secure the clip to the cam carrier.
- (18) Secure the clip to the oil pipe.
- (19) Electronic air by-pass valve connector
- (20) ON-OFF solenoid valve connector
- (21) Electronic wastegate valve connector

FUEL INJECTION (FUEL SYSTEMS)(H4DOTC) > General Description

PREPARATION TOOL

1. SUBARU SPECIAL TOOL


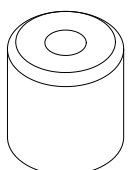
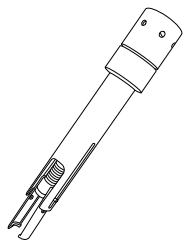
ILLUSTRATION	TOOL NUMBER	DESCRIPTION	REMARKS
 <p>ST18271AA030</p>	18271AA030	GUIDE	Used for installing the fuel injector seal.
 <p>ST18271AA040</p>	18271AA040	ADJUSTER	Used for installing the fuel injector seal.
 <p>ST18356AA010</p>	18356AA010	INJECTOR REMOVER	Used for removing the fuel injector.

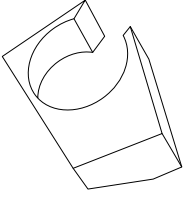
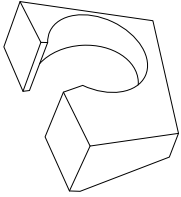
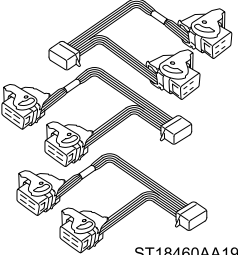
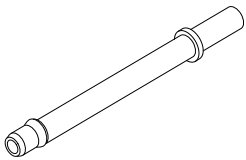
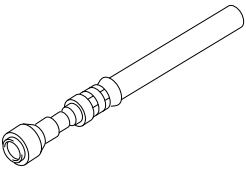
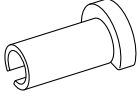
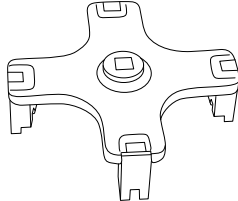

ILLUSTRATION	TOOL NUMBER	DESCRIPTION	REMARKS
 <p data-bbox="261 443 378 464">ST18362AA060</p>	18362AA060	ADAPTER R	Used for removing the fuel injector #1.
 <p data-bbox="261 747 378 768">ST18362AA070</p>	18362AA070	ADAPTER L	Used for removing the fuel injector #2.
 <p data-bbox="261 1052 378 1073">ST18460AA190</p>	18460AA190	CHECK BOARD	Used for measuring voltage and resistance of ECM terminals.
 <p data-bbox="261 1356 378 1377">ST18471AA000</p>	18471AA000	FUEL PIPE ADAPTER	Used for draining fuel.
 <p data-bbox="261 1661 378 1682">ST42075AG690</p>	42075AG690	FUEL HOSE	Used for draining fuel. <div data-bbox="789 1423 1208 1524" style="border: 1px solid black; padding: 5px;"> Note: This is the SUBARU genuine part. </div>

ILLUSTRATION	TOOL NUMBER	DESCRIPTION	REMARKS
 <p data-bbox="261 443 375 464">ST42099AE000</p>	42099AE000	QUICK CONNECTOR RELEASE	Used for removing the quick connector on the fuel hose.
 <p data-bbox="261 747 375 768">ST42099FL000</p>	42099FL000	ST FUEL PUMP	Used for removing and installing fuel pump and fuel sub level sensor.
 <p data-bbox="302 1052 375 1073">STSSM4</p>	—	SUBARU SELECT MONITOR 4	Used for setting of each function and troubleshooting for electrical system. <p data-bbox="789 852 854 873">Note:</p> <ul data-bbox="805 884 1195 1073" style="list-style-type: none"> • For detailed operation procedures, refer to “Help” of application. • Used together with interface for Subaru Select Monitor (such as DST-i and DST-010).

2. OTHER

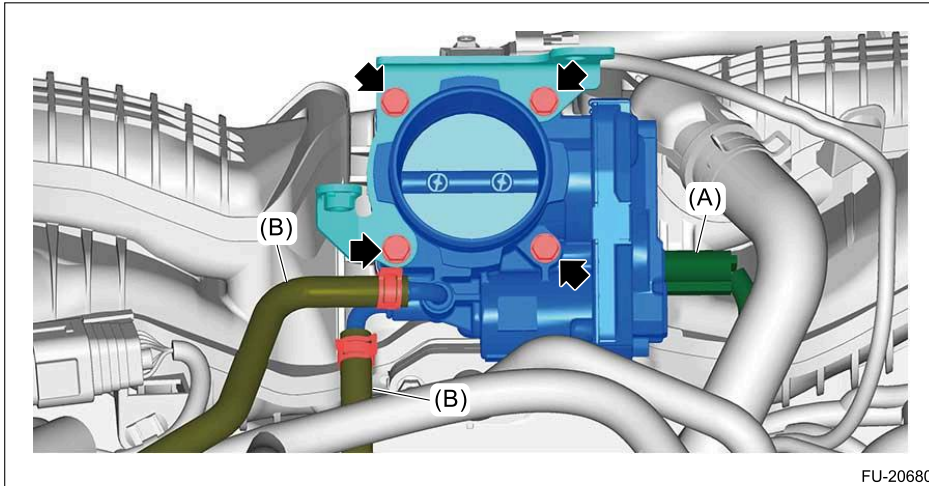
	REMARKS
TORX® E5	Used for removing and installing the EGR pipe stud bolts.
TORX PLUS® 40IP	Used for removing and installing high-pressure fuel pump.
Circuit tester	Used for measuring resistance, voltage and current.
Oscilloscope	Used for inspecting the waveform of each sensor.
Mighty Vac	Used for inspecting the manifold absolute pressure and intake air temperature sensor.

FUEL INJECTION (FUEL SYSTEMS)(H4DOTC) > Throttle Body

REMOVAL



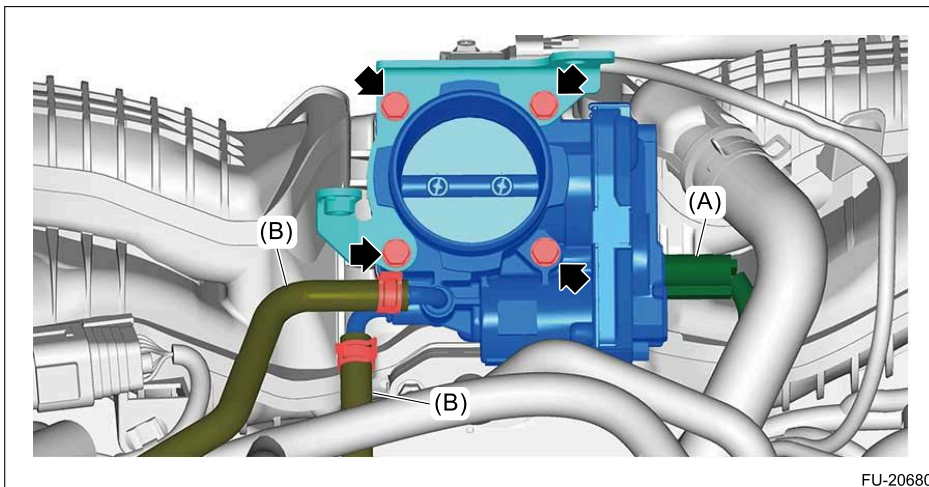
1. Disconnect the ground terminal from battery sensor. [Ref. to REPAIR CONTENTS>NOTE > BATTERY.](#)
2. Drain engine coolant. [Ref. to COOLING\(H4DOTC\)>Engine Coolant>REPLACEMENT > DRAINING OF ENGINE COOLANT.](#)
3. Remove the intercooler. [Ref. to INTAKE \(INDUCTION\)\(H4DOTC\)>Intercooler>REMOVAL.](#)
4. Disconnect the connector (A).
5. Disconnect the preheater hose (B).
6. Remove the throttle body together with the throttle body stay.



FUEL INJECTION (FUEL SYSTEMS)(H4DOTC) > Throttle Body

INSTALLATION

1. Set a new gasket, and install the throttle body together with the throttle body stay.
Tightening torque:
8 N·m (0.8 kgf-m, 5.9 ft-lb)
2. Connect the preheater hose (B).
3. Connect the connector (A).






4. Install the intercooler. [Ref. to INTAKE \(INDUCTION\)\(H4DOTC\)>Intercooler>INSTALLATION.](#)
5. Connect the ground terminal to battery sensor. [Ref. to REPAIR CONTENTS>NOTE > BATTERY.](#)
6. Fill engine coolant. [Ref. to COOLING\(H4DOTC\)>Engine Coolant>REPLACEMENT > FILLING OF ENGINE COOLANT.](#)

INSPECTION

1. THROTTLE SENSOR (METHOD WITH CIRCUIT TESTER)


Note:

Individual difference of the accelerator pedal may not be corrected sufficiently on the ECM side after the memory was cleared or the battery was removed and installed on the vehicle. Therefore, when the reference voltage is not reached after following the procedure, repeat the ignition switch ON (engine OFF) and ignition switch OFF operations 40 times at intervals of three seconds or more, and then measure the voltage again.

1. After warming-up the engine, turn the ignition switch to OFF.
2. Disconnect the ground terminal from battery sensor.  [Ref. to REPAIR CONTENTS>NOTE > BATTERY.](#)
3. Disconnect the connector from ECM.  [Ref. to FUEL INJECTION \(FUEL SYSTEMS\)\(H4DOTC\)>Engine Control Module \(ECM\)>REMOVAL.](#)
4. Attach the ST between the ECM, engine wiring harness and the bulkhead wiring harness.  [Ref. to ENGINE \(DIAGNOSTICS\) \(H4DOTC\)>General Description>PREPARATION TOOL > HOW TO USE CHECK BOARD.](#)

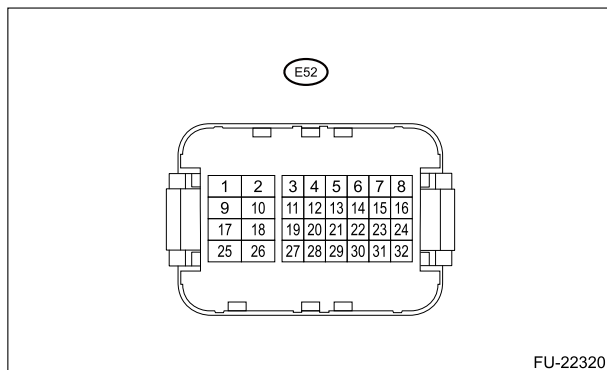
Special tool:

CHECK BOARD (18460AA190)

5. Connect the ground terminal to battery sensor.  [Ref. to REPAIR CONTENTS>NOTE > BATTERY.](#)
6. Turn the ignition switch to ON. (Engine OFF)
7. Check the voltage between ECM connector terminals when accelerator pedal is fully closed and fully open.

Check

- **When voltage is within standard values** → Normal
- **When voltage is not within standard values** → It is possible that there is a connector connection failure, harness open circuit, short circuit, or malfunction of the throttle body. Perform inspection or replacement.
- **If throttle sensor voltage does not change** → Go to step 8.



Throttle sensor	Accelerator pedal	Terminal No.	Standard
Main	Not depressed (full closed)	31 (+) – 23 (-)	Approx. 0.5 – 0.8 V
	Depressed (full opened)		Approx. 3.9 – 4.5 V
Sub	Not depressed (full closed)	15 (+) – 23 (-)	Approx. 0.6 – 1.2 V
	Depressed (full opened)		Approx. 4.2 – 4.5 V

8. Start the engine.
9. Check the voltage between ECM connector terminals when accelerator pedal is fully closed and fully open.

Caution:

When depressing the accelerator pedal to fully open, perform it in as short a time as possible, but within the range where the inspection result is not adversely affected.

Note:

Perform the inspection in the following conditions.

- For AT model or CVT model: Select lever is in "P" range.
- For MT model: Gear shift lever is in the neutral position.
- Parking brake activated

Check

- When voltage is within standard values → Normal
- When voltage is not within standard values → It is possible that there is a connector connection failure, harness open circuit, short circuit, or malfunction of the throttle body. Perform inspection or replacement.


10. After inspection, install the related parts in the reverse order of removal.


Note:

For installation procedures of ECM connectors, refer to Engine Control Module (ECM).  [Ref. to FUEL INJECTION \(FUEL SYSTEMS\)\(H4DOTC\)>Engine Control Module \(ECM\)>INSTALLATION.](#)

2. THROTTLE SENSOR (METHOD WITH SUBARU SELECT MONITOR)

Note:

- Individual difference of the accelerator pedal may not be corrected sufficiently on the ECM side after the memory was cleared or the battery was removed and installed on the vehicle. Therefore, using the Subaru Select Monitor, check that the accelerator opening angle signal indicates [100%], when the accelerator pedal is fully depressed, and then perform the inspection.
- If the accelerator opening angle signal does not indicate [100%], check the accelerator pedal.  [Ref. to SPEED CONTROL SYSTEMS\(H4DOTC\)>Accelerator Pedal>INSPECTION.](#)

1. After warming-up the engine, turn the ignition switch to OFF.
2. Turn the ignition switch to ON. (Engine OFF)
3. Using the Subaru Select Monitor, read the accelerator opening angle signal and throttle sensor voltage when accelerator pedal is fully closed and fully open.  [Ref. to ENGINE \(DIAGNOSTICS\)\(H4DOTC\)>Data Monitor.](#)

Note:

Due to the specification of the Subaru Select Monitor, value read from the accelerator opening angle signal is highlighted and displayed as the voltage readings of sub throttle sensor.

Check

- When voltage is within standard values → Normal
- When voltage is not within standard values → It is possible that there is a connector connection failure, harness open circuit, short circuit, or malfunction of the throttle body. Perform inspection or replacement.
- If throttle sensor voltage does not change → Go to step 4.

Throttle sensor	Accelerator pedal	Acceleration opening angle signal	Standard
Main	Not depressed (full closed)	0.0 %	Approx. 0.7 V
	Depressed (full opened)	100.0 %	Approx. 3.9 V
Sub	Not depressed (full closed)	0.0 %	Approx. 0.7 V
	Depressed (full opened)	100.0 %	Approx. 3.9 V

4. Start the engine.
5. Using the Subaru Select Monitor, read the accelerator opening angle signal and throttle sensor voltage when accelerator pedal is fully closed and fully open.

Caution:

When depressing the accelerator pedal to fully open, perform it in as short a time as possible, but within the range where the inspection result is not adversely affected.

Note:

Perform the inspection in the following conditions.

- For AT model or CVT model: Select lever is in "P" range.
- For MT model: Gear shift lever is in the neutral position.
- Parking brake activated

Check

- **When voltage is within standard values** → Normal
- **When voltage is not within standard values** → It is possible that there is a connector connection failure, harness open circuit, short circuit, or malfunction of the throttle body. Perform inspection or replacement.

3. OTHER INSPECTIONS

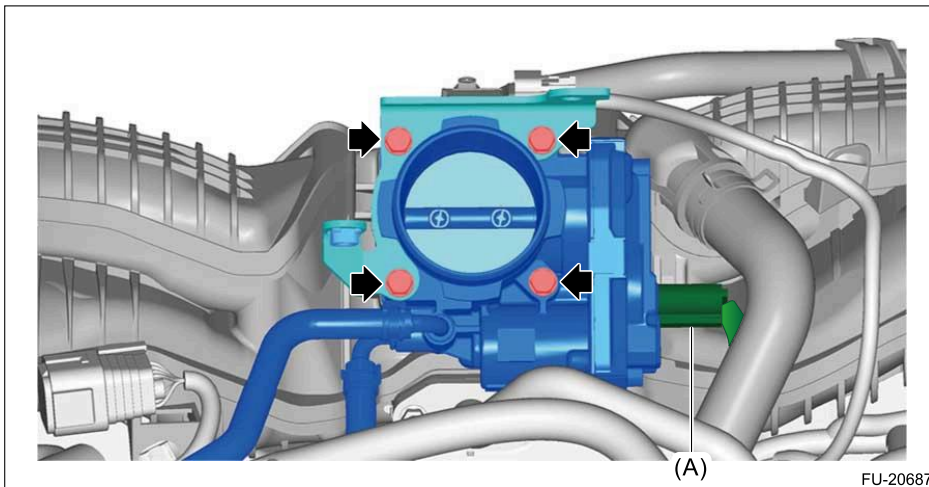
- 1.** Check that the throttle body has no deformation, cracks or other damages.
- 2.** Check that the preheater hose has no cracks, damage or loose part.

FUEL INJECTION (FUEL SYSTEMS)(H4DOTC) > Intake Manifold Assembly

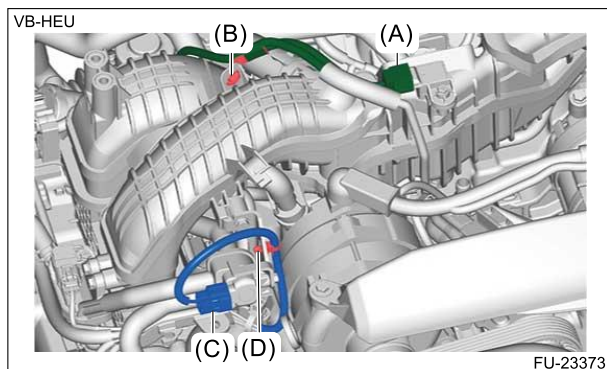
REMOVAL



1. Release the fuel pressure. [Ref. to FUEL INJECTION \(FUEL SYSTEMS\)\(H4DOTC\)>Fuel>PROCEDURE > RELEASING OF FUEL PRESSURE.](#)
2. Open the fuel filler lid and remove the fuel filler cap.
Note:
This operation is required to release the inner pressure of the fuel tank.
3. Disconnect the ground terminal from battery sensor. [Ref. to REPAIR CONTENTS>NOTE > BATTERY.](#)
4. Remove the intercooler. [Ref. to INTAKE \(INDUCTION\)\(H4DOTC\)>Intercooler>REMOVAL.](#)
5. Remove the intake duct No. 2. [Ref. to INTAKE \(INDUCTION\)\(H4DOTC\)>Intake Duct>REMOVAL > INTAKE DUCT NO. 2.](#)
6. Remove the PCV pipe assembly. [Ref. to EMISSION CONTROL \(AUX. EMISSION CONTROL DEVICES\)\(H4DOTC\)>PCV Pipe>REMOVAL.](#)
7. When the engine coolant remains before removing the intake manifold assembly
 - (1) Disconnect the connector (A).
 - (2) Remove the bolts securing the throttle body and throttle body stay, and move the throttle body aside so that it does not interfere with the work.

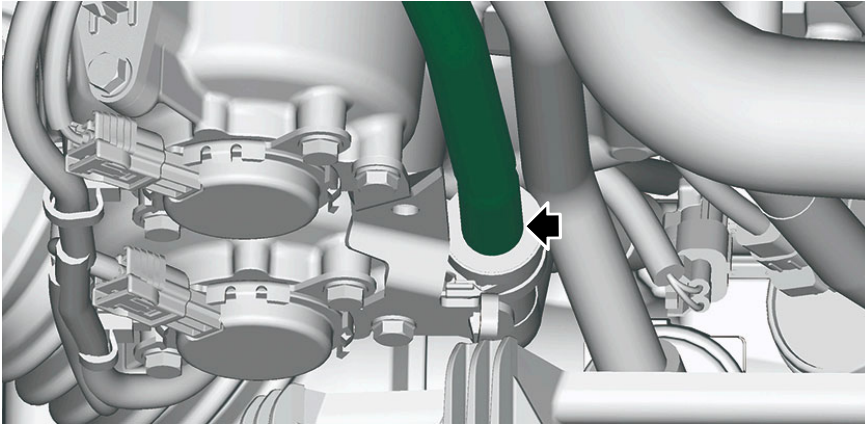


8. When the engine coolant has been drained before removing the intake manifold assembly
 - (1) Remove the throttle body. [Ref. to FUEL INJECTION \(FUEL SYSTEMS\)\(H4DOTC\)>Throttle Body>REMOVAL.](#)
9. Disconnect the connector (A) and remove the clip (B).
10. Disconnect the connector (C) and remove the clip (D).




11. Disconnect the vacuum hose.

VB-HBU



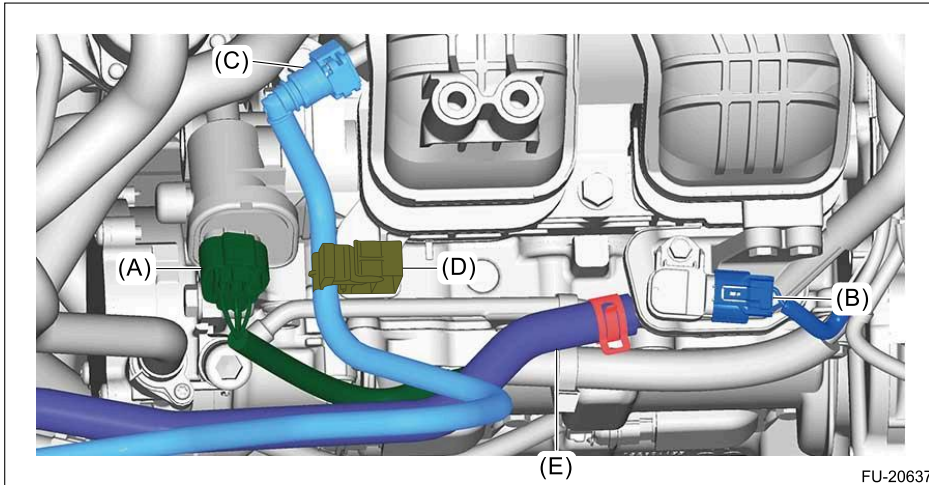
FU-22274

12. Remove the connector (A) and connector (B).

13. Disconnect the fuel delivery tube (C).  Ref. to [FUEL INJECTION \(FUEL SYSTEMS\)\(H4DOTC\)>Fuel Delivery and Evaporation Lines>REMOVAL > QUICK CONNECTOR DISCONNECTION \(TYPE A\)](#).

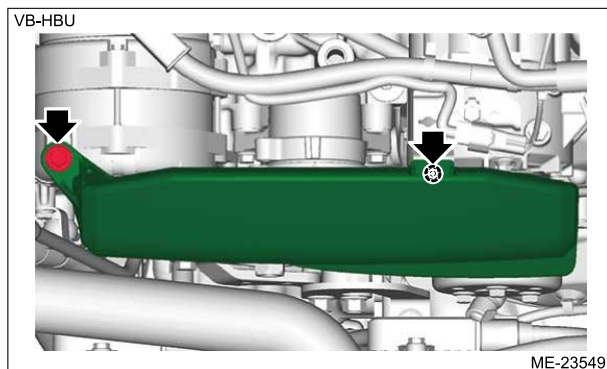
14. Remove the fuel delivery tube clamp (D).

15. Disconnect the evaporation hose (E).

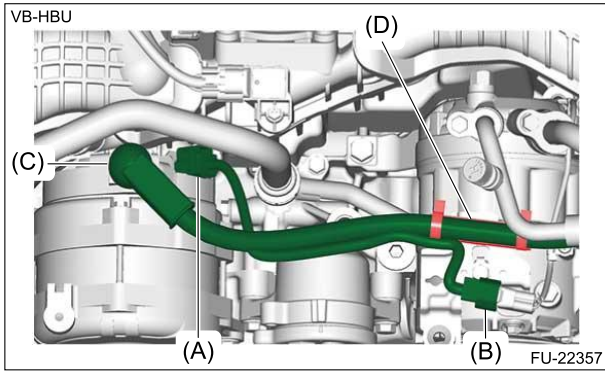


FU-20637

16. Remove the V-belt covers.

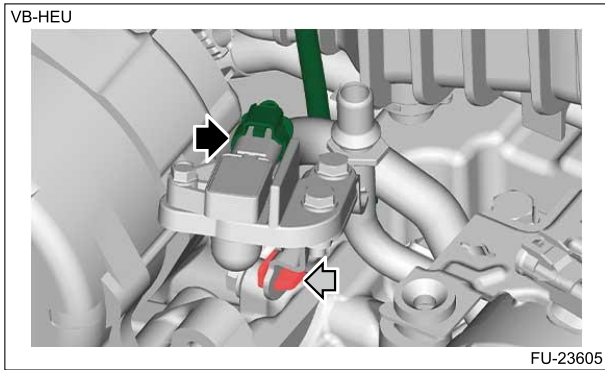


17. Disconnect the connector (A), connector (B) and terminal (C), and remove the clip (D).

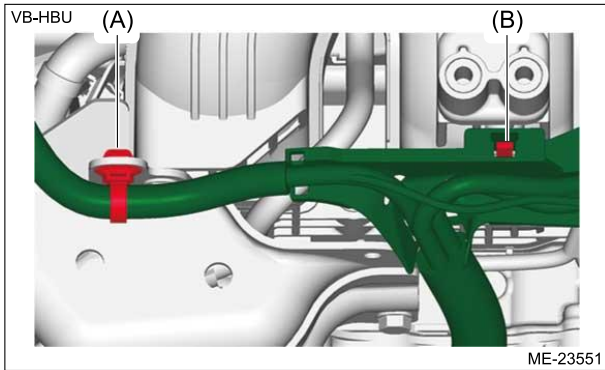


18. Remove the V-belt tensioner assembly.  Ref. to [MECHANICAL\(H4DOTC\)>V-belt>REMOVAL > V-BELT TENSIONER ASSEMBLY.](#)

19. Disconnect the connector from the pressure sensor and remove the clip.

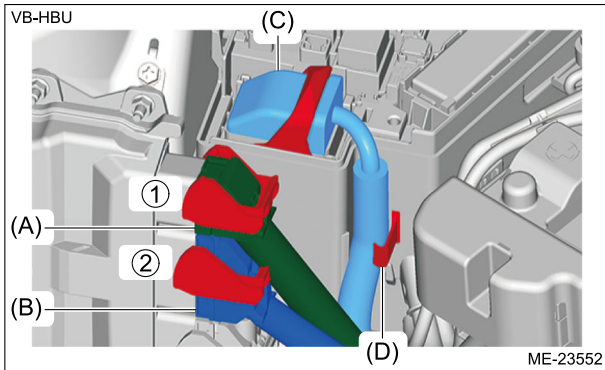


20. Remove the clip (A) securing battery cable assembly and release the claw (B).

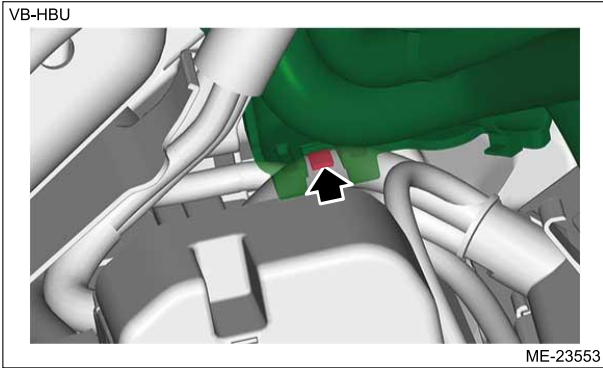


21. Remove the connector (A) and connector (B) in numerical order shown in figure.

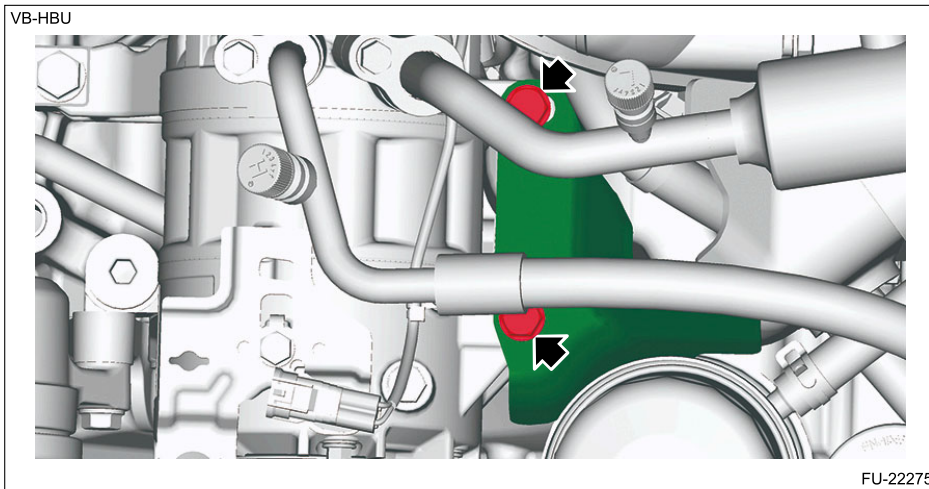
22. Disconnect the connector (C), and remove the engine wiring harness from the clip (D).



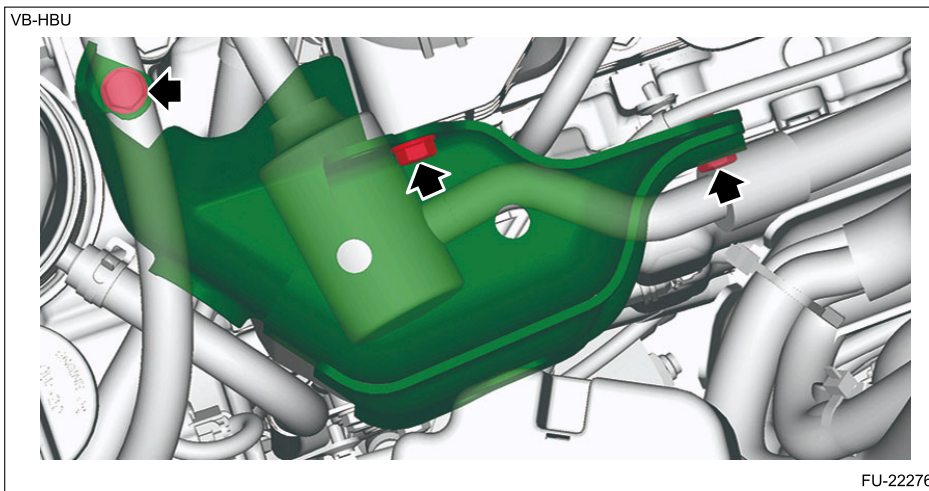
23. Release the claw securing the engine wiring harness to the bracket, and place it aside so that it does not interfere with work.




24. Remove the fuel pipe protector No. 1.



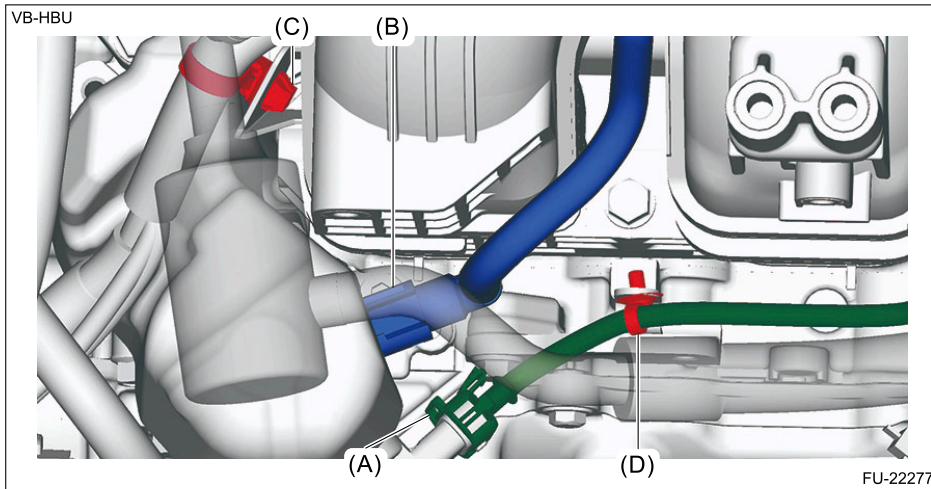
25. Remove the fuel pipe protector No. 2.



26. Disconnect the connector (A).

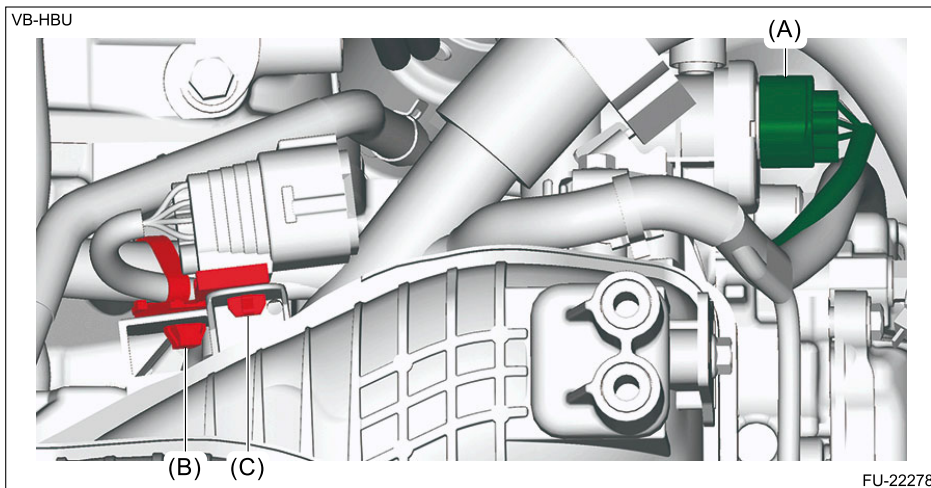
27. Disconnect the fuel delivery pipe (B).  [Ref. to FUEL INJECTION \(FUEL SYSTEMS\)\(H4DOTC\)>Fuel Delivery and Evaporation Lines>REMOVAL > QUICK CONNECTOR DISCONNECTION \(TYPE B\).](#)

28. Remove the clip (C) and clip (D).



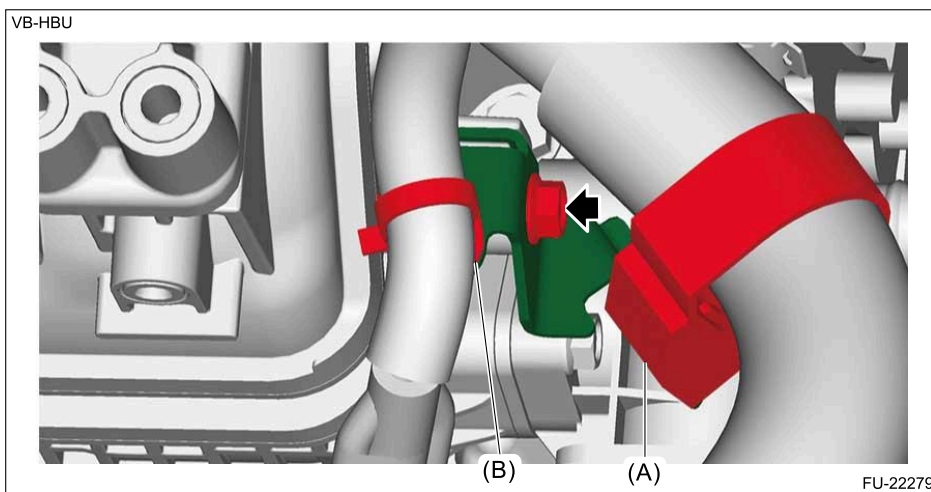
29. Disconnect the connector (A).

30. Remove the clip (B) and clip (C).



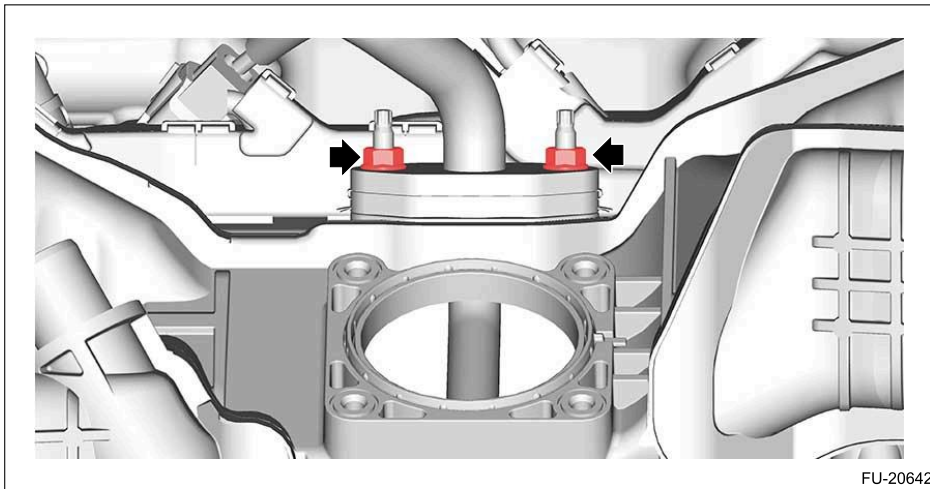
31. Remove the clip (A) from the harness stay.

32. Remove the harness stay and remove the clip (B).

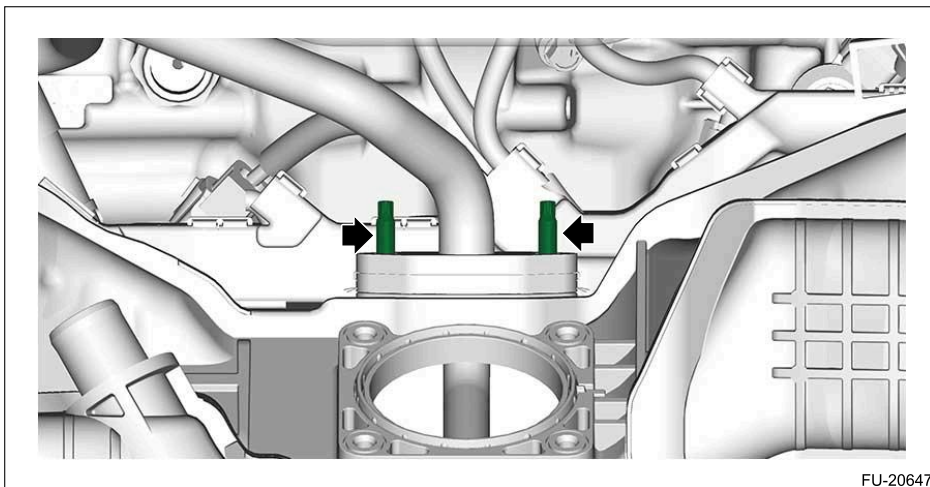


33. Remove the PCV hose.  [Ref. to EMISSION CONTROL \(AUX. EMISSION CONTROL DEVICES\)\(H4DOTC\)>PCV Hose>REMOVAL.](#)

34. Remove the nuts securing the EGR pipe No. 2.



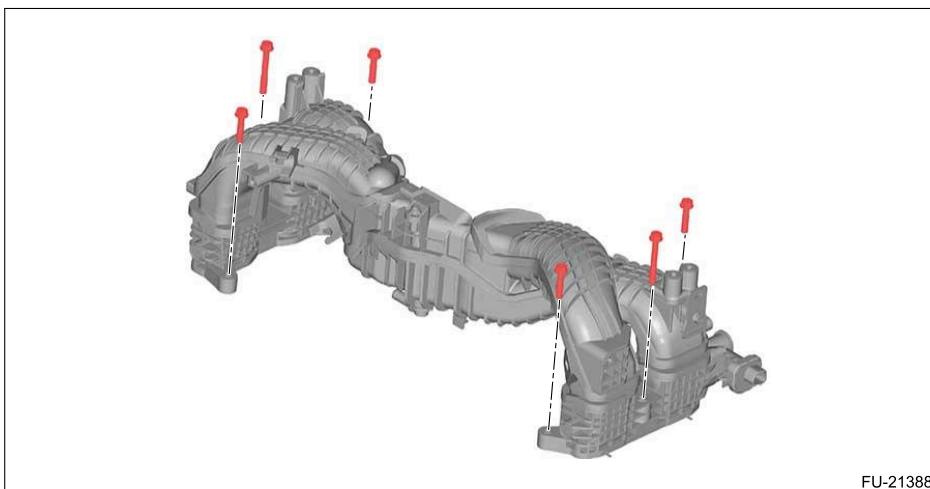
35. Remove the stud bolts using TORX® E5.



36. Remove the intake manifold assembly.

Caution:

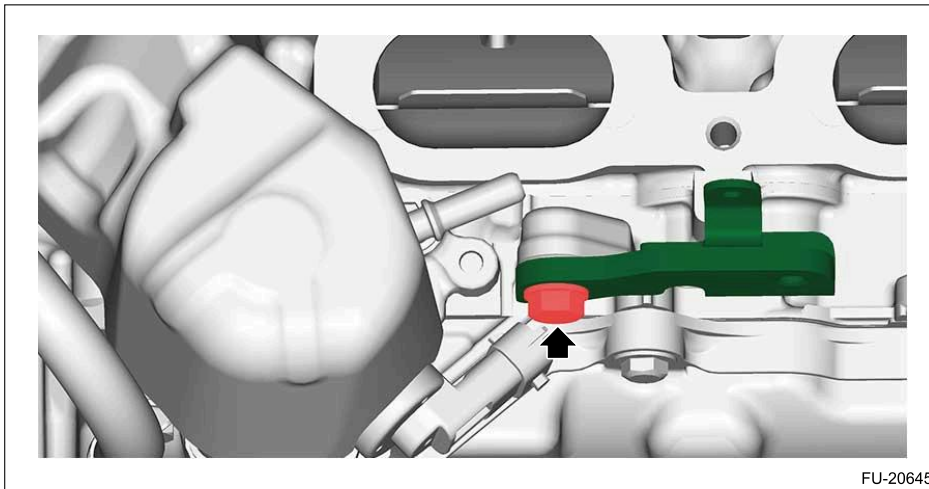
Remove the intake manifold assembly so that it is not damaged by adjacent parts.



37. Remove the fuel pipe protector stay.

Note:

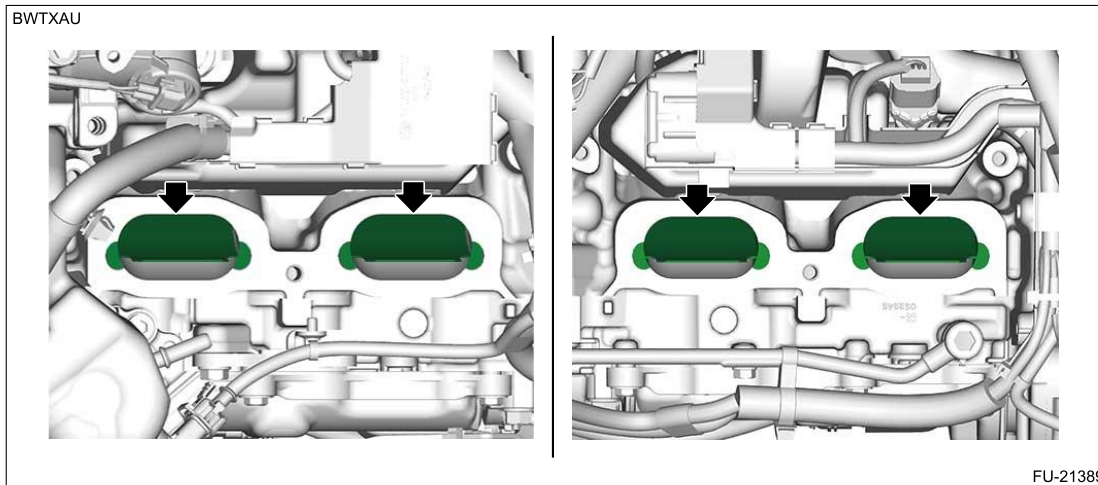
Perform this procedure only when required.



38. Remove the cylinder head plate from cylinder head.

Note:

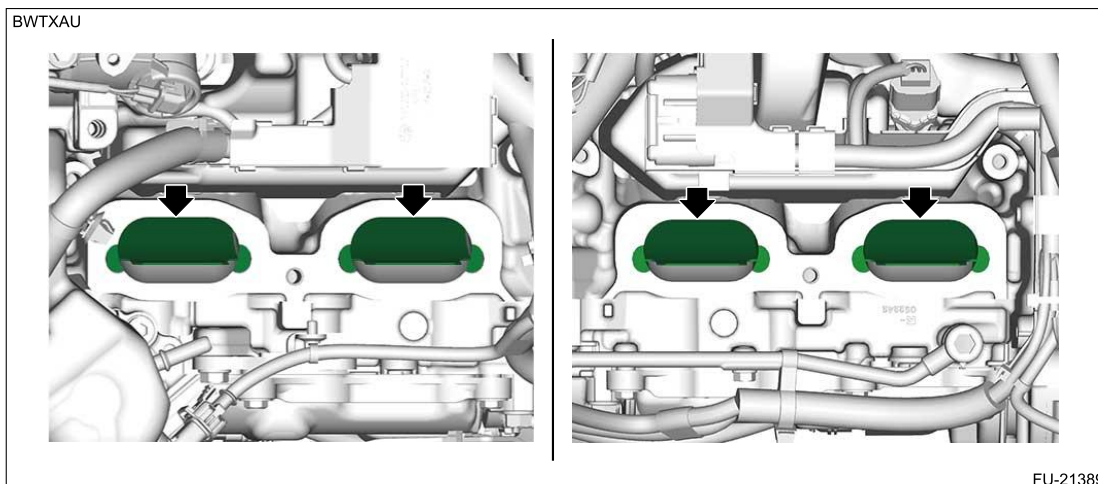
Perform this procedure only when required.



FUEL INJECTION (FUEL SYSTEMS)(H4DOTC) > Intake Manifold Assembly

INSTALLATION

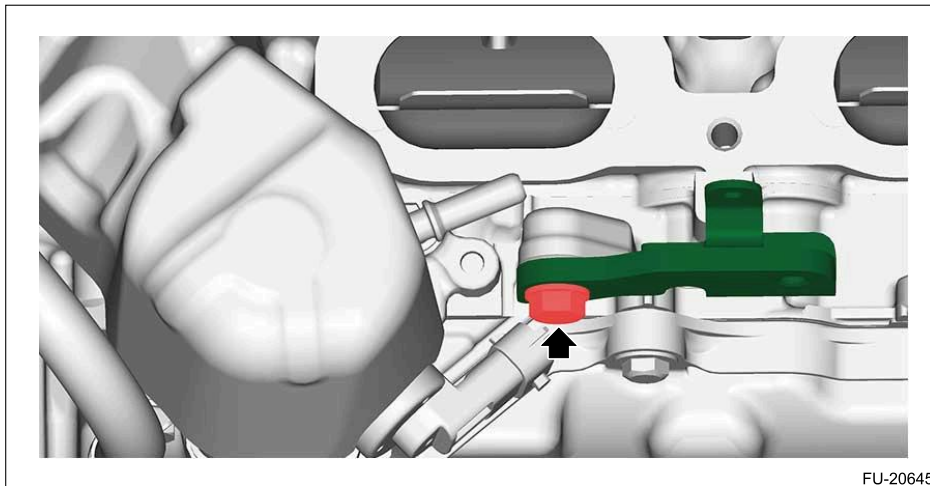
1. Install the cylinder head plate to the cylinder head.



2. Install the fuel pipe protector stay.

Tightening torque:

19 N·m (1.9 kgf-m, 14.0 ft-lb)



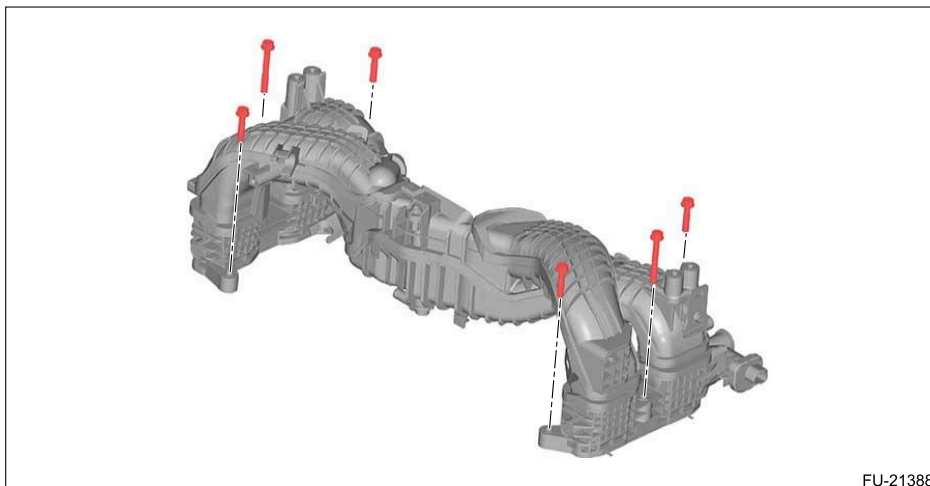
3. Set a new gasket and install the intake manifold assembly.

Caution:

- Install the intake manifold assembly so that it is not damaged by adjacent parts.
- Be careful not to let the engine wiring harness be caught by the parts.

Tightening torque:

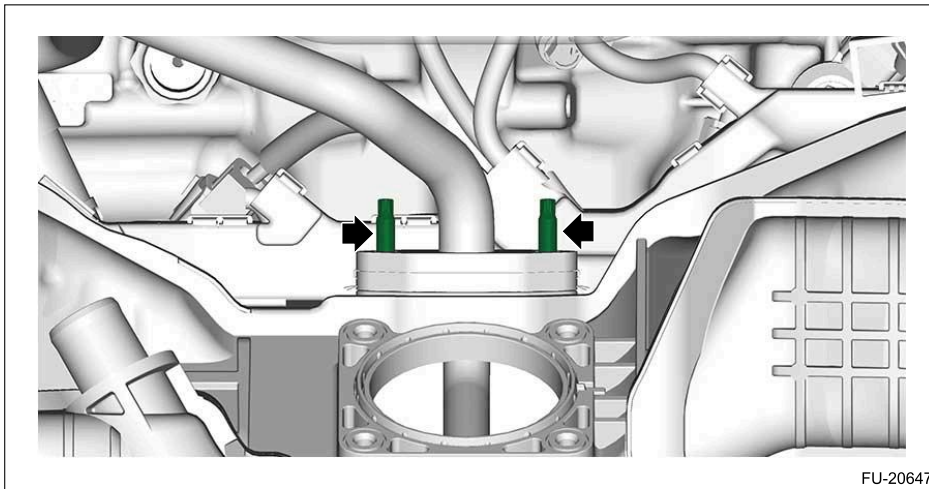
25 N·m (2.5 kgf-m, 18.4 ft-lb)



4. Set a new gasket, and install the stud bolts using TORX® E5.

Tightening torque:

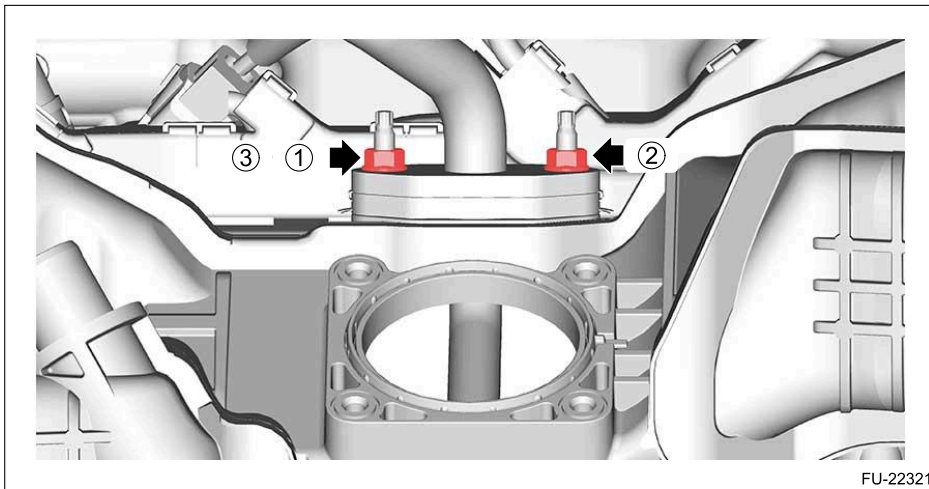
6.4 N·m (0.7 kgf-m, 4.7 ft-lb)



5. Temporarily attach the EGR pipe No. 2 and tighten it in order of ①→②→③.

Tightening torque:

9 N·m (0.9 kgf-m, 6.6 ft-lb)



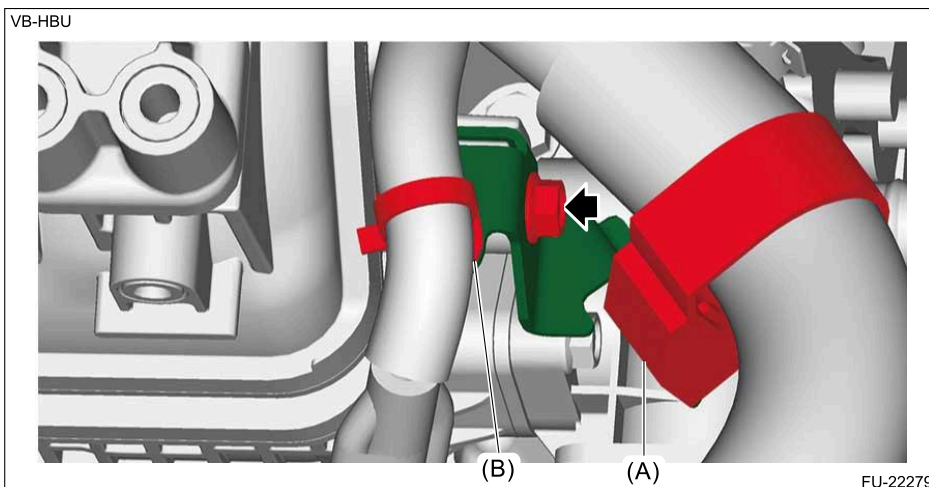
6. Install the PCV hose. [Ref. to EMISSION CONTROL \(AUX. EMISSION CONTROL DEVICES\)\(H4DOTC\)>PCV Hose>INSTALLATION.](#)

7. Install the harness stay.

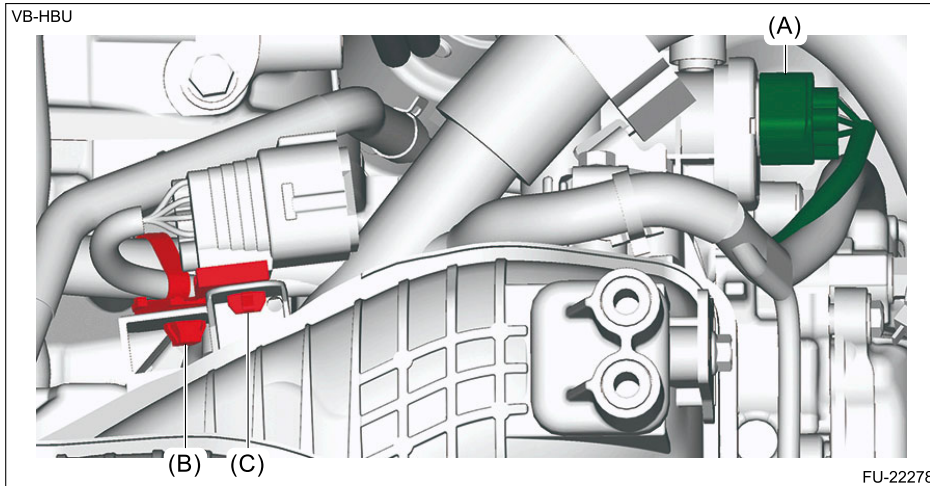
Tightening torque:

6.4 N·m (0.7 kgf-m, 4.7 ft-lb)

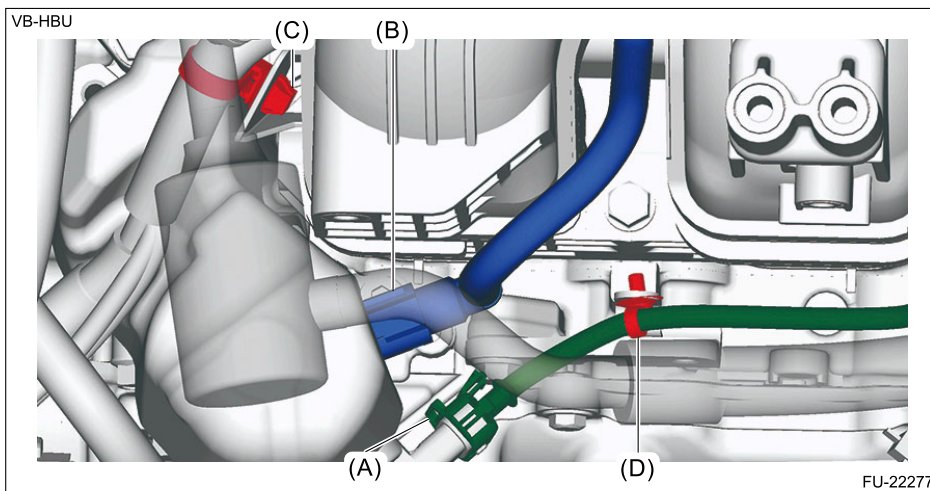
8. Install the clip (A) and clip (B) to the harness stay.



- 9. Connect the connector (A).
- 10. Install the clip (B) and clip (C).



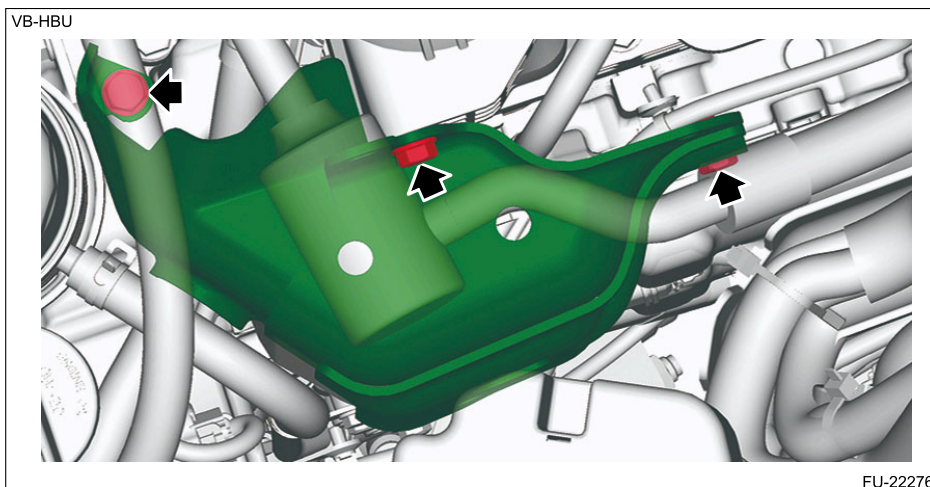
- 11. Install the clip (C) and clip (D).
- 12. Connect the fuel delivery pipe (B). [Ref. to FUEL INJECTION \(FUEL SYSTEMS\)\(H4DOTC\)>Fuel Delivery and Evaporation Lines>INSTALLATION > QUICK CONNECTOR CONNECTION \(TYPE B\).](#)
- 13. Connect the connector (A).



- 14. Temporarily install the fuel pipe protector No. 2, and tighten the bolts.

Tightening torque:

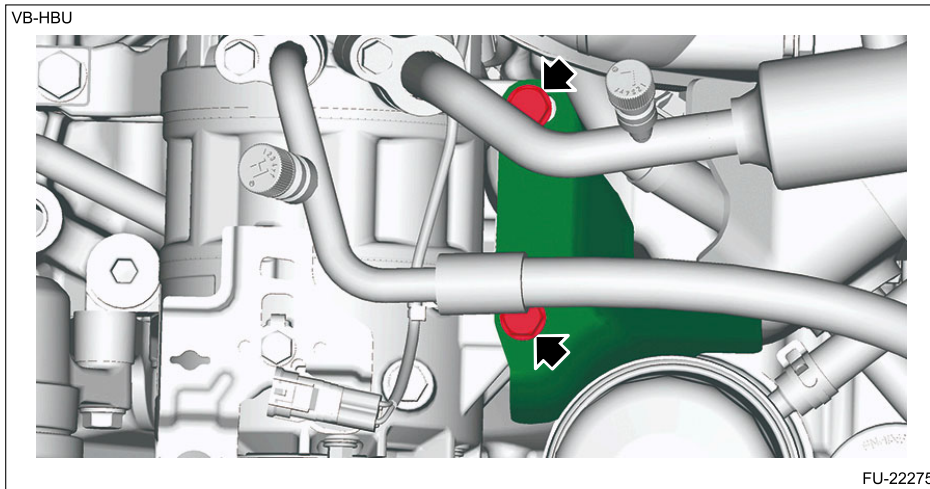
19 N·m (1.9 kgf-m, 14.0 ft-lb)



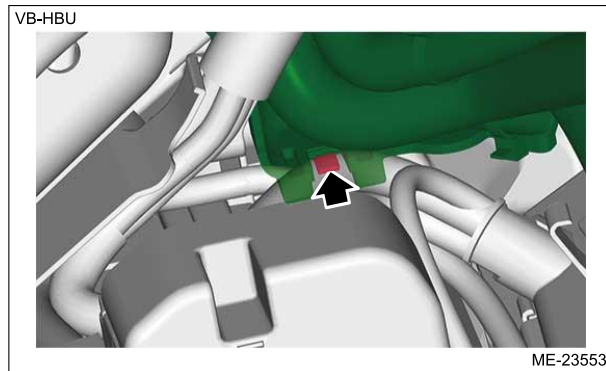
15. Install the fuel pipe protector No. 1.

Tightening torque:

25 N·m (2.5 kgf-m, 18.4 ft-lb)

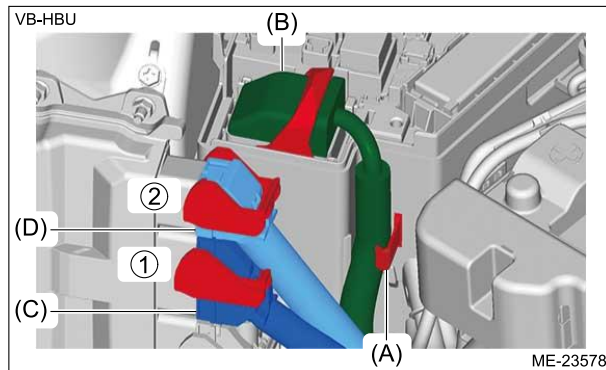


16. Set the engine wiring harness and secure the engine wiring harness to the bracket with the claw.

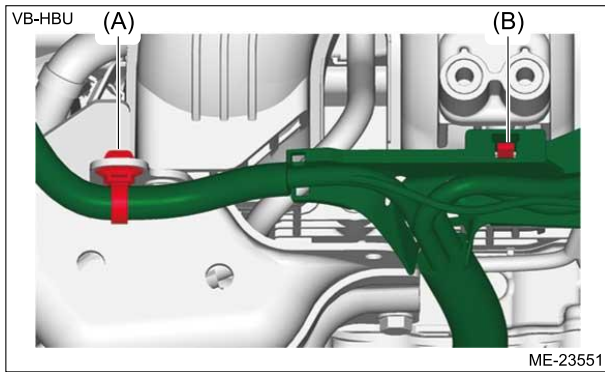


17. Install the engine wiring harness to the clip (A), and connect the connector (B).

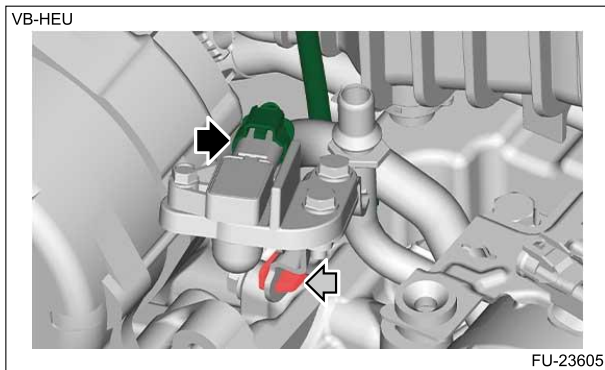
18. Connect the connector (C) and connector (D) in numerical order shown in figure.



19. Secure the battery cable assembly with the claw (B) and clip (A).



20. Connect the connector to the pressure sensor and install the clip.



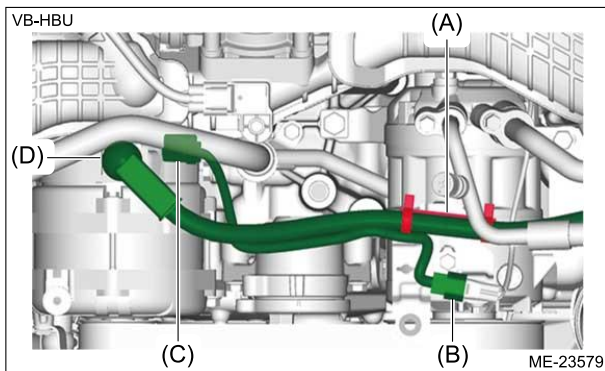
21. Install the V-belt tensioner assembly.  Ref. to [MECHANICAL\(H4DOTC\)>V-belt>INSTALLATION > V-BELT TENSIONER ASSEMBLY](#).

22. Secure the battery cable assembly with the clip (A).

23. Connect the connector (B), connector (C) and terminal (D).

Tightening torque:

15.5 N·m (1.6 kgf-m, 11.4 ft-lb)



24. Install the V-belt cover.

Note:


- Check the grommet for peel-off or disengagement.
- Be careful not to deform the bracket during installation.

Tightening torque:

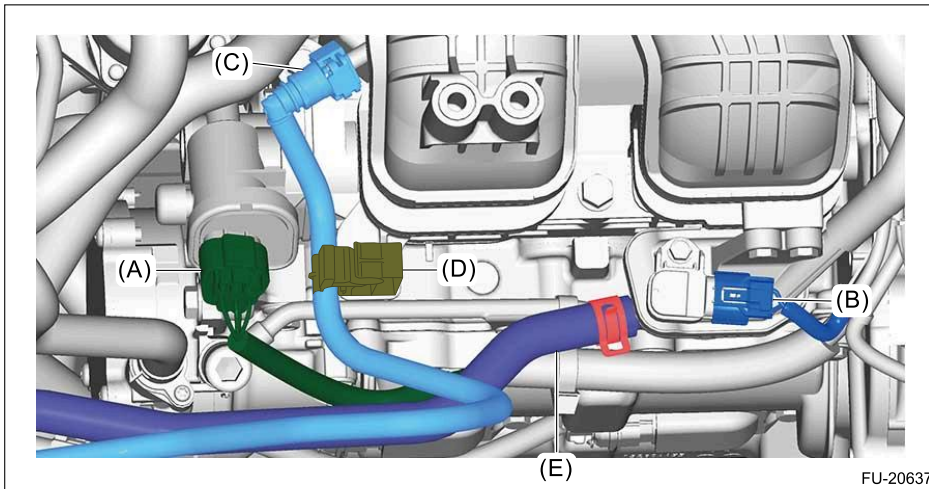
7 N·m (0.7 kgf-m, 5.2 ft-lb)

25. Connect the evaporation hose (E).

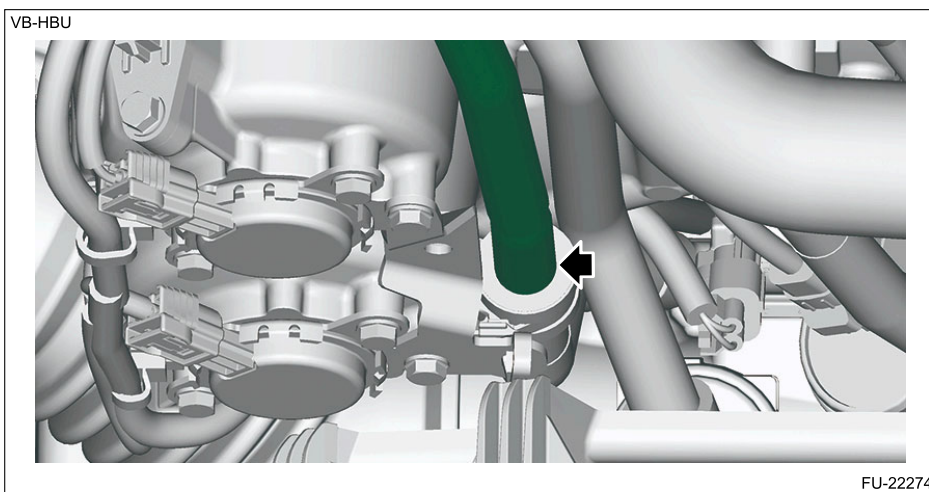
26. Install the fuel delivery tube clamp (D).

27. Connect the fuel delivery tube (C).  Ref. to [FUEL INJECTION \(FUEL SYSTEMS\)\(H4DOTC\)>Fuel Delivery and Evaporation Lines>INSTALLATION > QUICK CONNECTOR CONNECTION \(TYPE A\)](#).

28. Connect the connector (A) and connector (B).

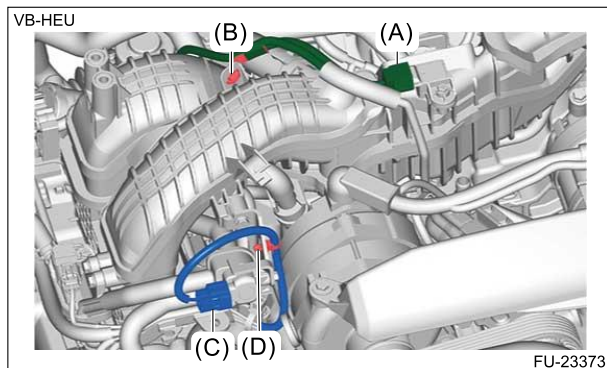


29. Connect the vacuum hose.



30. Connect the connector (C) and secure it with the clip (D).

31. Connect the connector (A) and secure it with clip (B).




32. Install the PCV pipe assembly.  [Ref. to EMISSION CONTROL \(AUX. EMISSION CONTROL DEVICES\)\(H4DOTC\)>PCV Pipe>INSTALLATION.](#)

33. Install the throttle body.  [Ref. to FUEL INJECTION \(FUEL SYSTEMS\)\(H4DOTC\)>Throttle Body>INSTALLATION.](#)

34. Install the intake duct No. 2.  [Ref. to INTAKE \(INDUCTION\)\(H4DOTC\)>Intake Duct>INSTALLATION > INTAKE DUCT NO. 2.](#)

35. Install the intercooler.  [Ref. to INTAKE \(INDUCTION\)\(H4DOTC\)>Intercooler>INSTALLATION.](#)

36. Connect the ground terminal to battery sensor.  [Ref. to REPAIR CONTENTS>NOTE > BATTERY.](#)

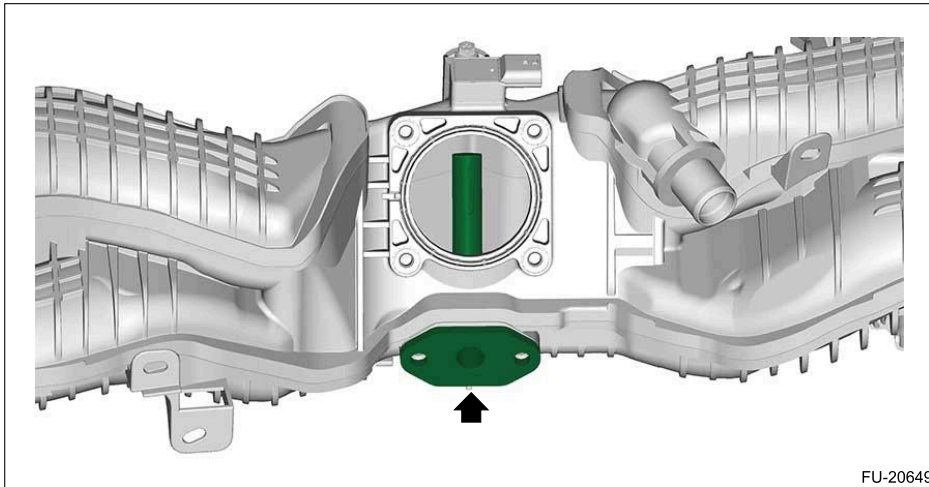
37. Install the fuel filler cap, and close the fuel filler lid.

FUEL INJECTION (FUEL SYSTEMS)(H4DOTC) > Intake Manifold Assembly





DISASSEMBLY

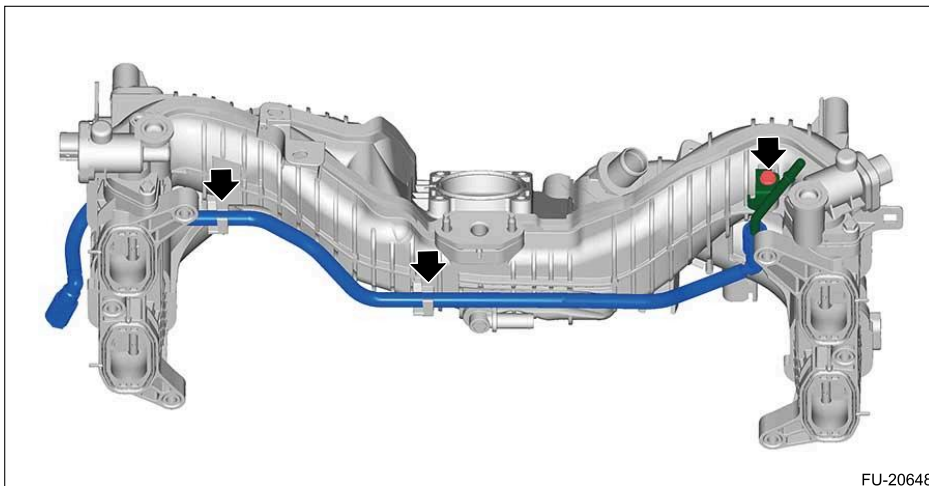


1. Remove the EGR pipe No. 1.




FU-20649


2. Remove the purge control solenoid valve.  Ref. to [EMISSION CONTROL \(AUX. EMISSION CONTROL DEVICES\) \(H4DOTC\)>Purge Control Solenoid Valve>REMOVAL](#).
3. Remove the manifold absolute pressure and intake air temperature sensor.  Ref. to [FUEL INJECTION \(FUEL SYSTEMS\) \(H4DOTC\)>Manifold Absolute Pressure and Intake Air Temperature Sensor>REMOVAL](#).
4. Remove the check valve.  Ref. to [EMISSION CONTROL \(AUX. EMISSION CONTROL DEVICES\)\(H4DOTC\)>Check Valve>REMOVAL](#).
5. Remove the vacuum pipe assembly.  Ref. to [EMISSION CONTROL \(AUX. EMISSION CONTROL DEVICES\)\(H4DOTC\)>Vacuum Pipe Assembly>REMOVAL](#).
6. Remove the fuel pipe and fuel delivery pipe.



FU-20648

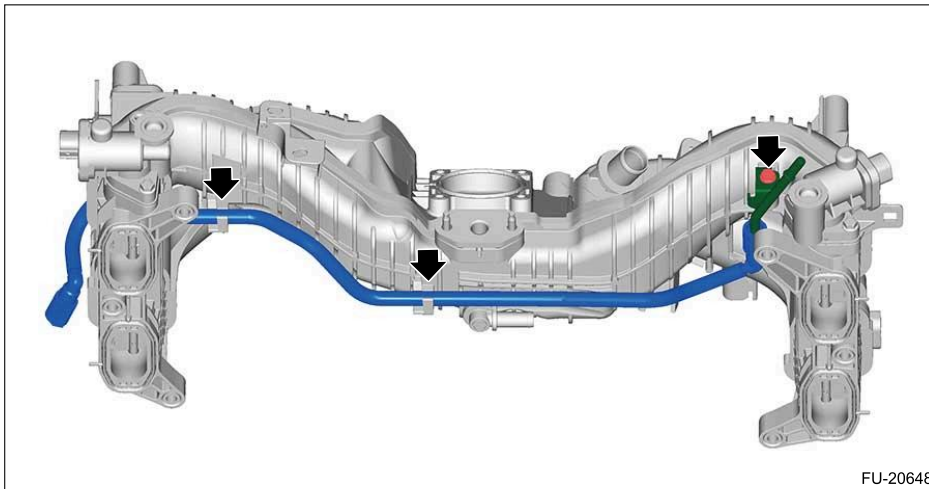
7. Disconnect the fuel delivery pipe from the fuel pipe.  Ref. to [FUEL INJECTION \(FUEL SYSTEMS\)\(H4DOTC\)>Fuel Delivery and Evaporation Lines>REMOVAL > QUICK CONNECTOR DISCONNECTION \(TYPE B\)](#).





FUEL INJECTION (FUEL SYSTEMS)(H4DOTC) > Intake Manifold Assembly ASSEMBLY

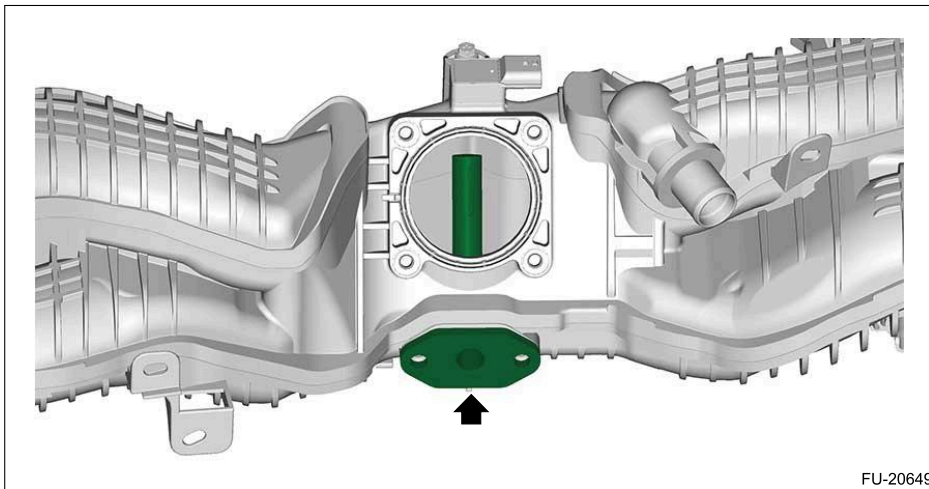
1. Connect the fuel delivery pipe to the fuel pipe.  Ref. to [FUEL INJECTION \(FUEL SYSTEMS\)\(H4DOTC\)>Fuel Delivery and Evaporation Lines>INSTALLATION > QUICK CONNECTOR CONNECTION \(TYPE B\)](#).
2. Install the fuel pipe and fuel delivery pipe.

Tightening torque:

6.4 N·m (0.7 kgf-m, 4.7 ft-lb)



3. Install the vacuum pipe assembly.  [Ref. to EMISSION CONTROL \(AUX. EMISSION CONTROL DEVICES\)\(H4DOTC\)>Vacuum Pipe Assembly>INSTALLATION.](#)
4. Install the check valve.  [Ref. to EMISSION CONTROL \(AUX. EMISSION CONTROL DEVICES\)\(H4DOTC\)>Check Valve>INSTALLATION.](#)
5. Install the manifold absolute pressure and intake air temperature sensor.  [Ref. to FUEL INJECTION \(FUEL SYSTEMS\)\(H4DOTC\)>Manifold Absolute Pressure and Intake Air Temperature Sensor>INSTALLATION.](#)
6. Install the purge control solenoid valve.  [Ref. to EMISSION CONTROL \(AUX. EMISSION CONTROL DEVICES\)\(H4DOTC\)>Purge Control Solenoid Valve>INSTALLATION.](#)
7. Set a new gasket, and temporarily install the EGR pipe No. 1.



FUEL INJECTION (FUEL SYSTEMS)(H4DOTC) > Intake Manifold Assembly

INSPECTION



1. Check that the intake manifold assembly and the fuel pipe have no deformation, cracks and other damages.
2. Check that the hose has no cracks, damage or loose part.
3. Check tumble generator valve for contamination or clogging.

FUEL INJECTION (FUEL SYSTEMS)(H4DOTC) > Tumble Generator Valve

SPECIFICATION

The tumble generator valve is integrated in the intake manifold assembly.



Refer to "Intake Manifold Assembly" for removal and installation.

-  [Ref. to FUEL INJECTION \(FUEL SYSTEMS\)\(H4DOTC\)>Intake Manifold Assembly>REMOVAL.](#)
-  [Ref. to FUEL INJECTION \(FUEL SYSTEMS\)\(H4DOTC\)>Intake Manifold Assembly>INSTALLATION.](#)

FUEL INJECTION (FUEL SYSTEMS)(H4DOTC) > Tumble Generator Valve Actuator

SPECIFICATION

The tumble generator valve actuator cannot be disassembled.

-  [Ref. to FUEL INJECTION \(FUEL SYSTEMS\)\(H4DOTC\)>Intake Manifold Assembly>REMOVAL.](#)
-  [Ref. to FUEL INJECTION \(FUEL SYSTEMS\)\(H4DOTC\)>Intake Manifold Assembly>INSTALLATION.](#)

FUEL INJECTION (FUEL SYSTEMS)(H4DOTC) > Fuel Insulator

REMOVAL



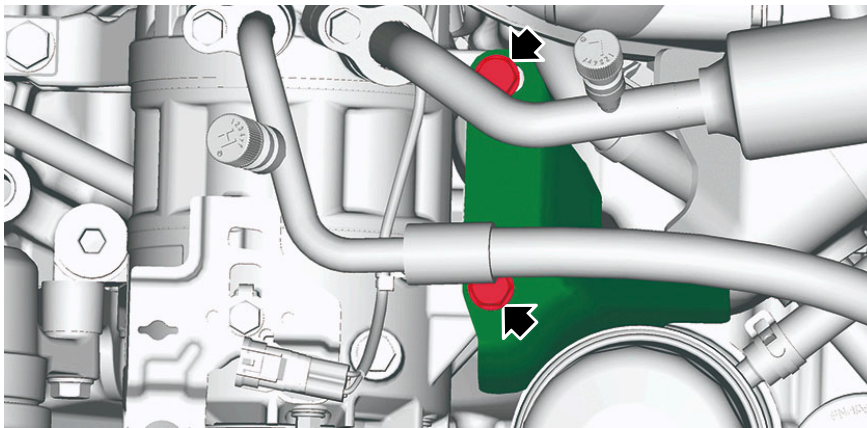
1. Disconnect the ground terminal from battery sensor. [Ref. to REPAIR CONTENTS>NOTE > BATTERY.](#)
2. Remove the intake manifold assembly. [Ref. to FUEL INJECTION \(FUEL SYSTEMS\)\(H4DOTC\)>Intake Manifold Assembly>REMOVAL.](#)
3. Move the A/C compressor aside so that it does not interfere with the work.

Note:

This procedure is required to remove the fuel pump insulator.

- (1) Remove the V-belts. [Ref. to MECHANICAL\(H4DOTC\)>V-belt>REMOVAL > V-BELT.](#)
- (2) Remove the fuel pipe protector No. 1.

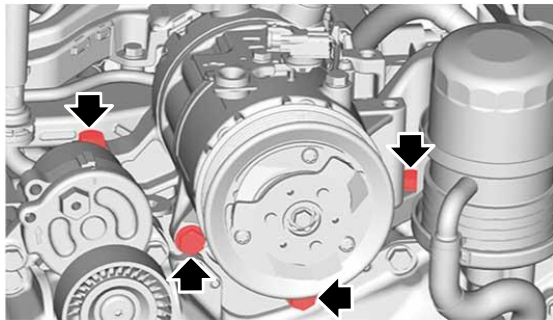
VB-HBU



FU-22275

- (3) Remove the bolt securing the A/C compressor.

VB-HBU



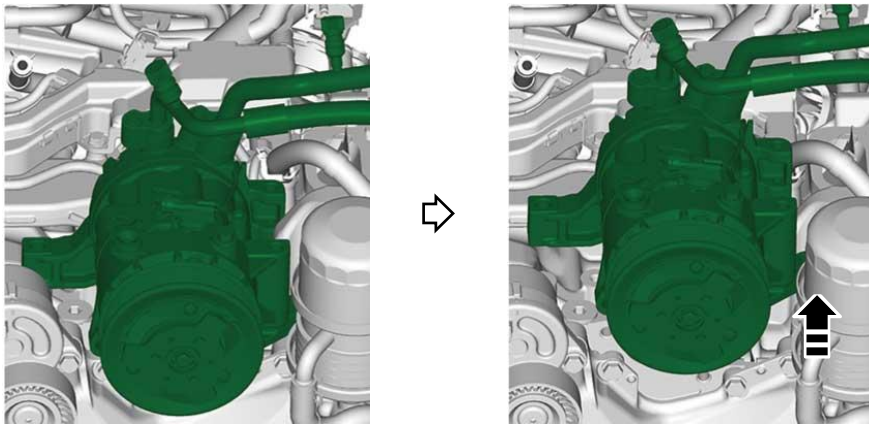
FU-22297

- (4) Move the A/C compressor as shown in the figure.

Caution:

- Do not bend the pipe portion of the hose pressure discharge and the hose pressure suction.
- Be careful not to drop the A/C compressor.
- Be careful not to damage the adjacent parts with the A/C compressor.

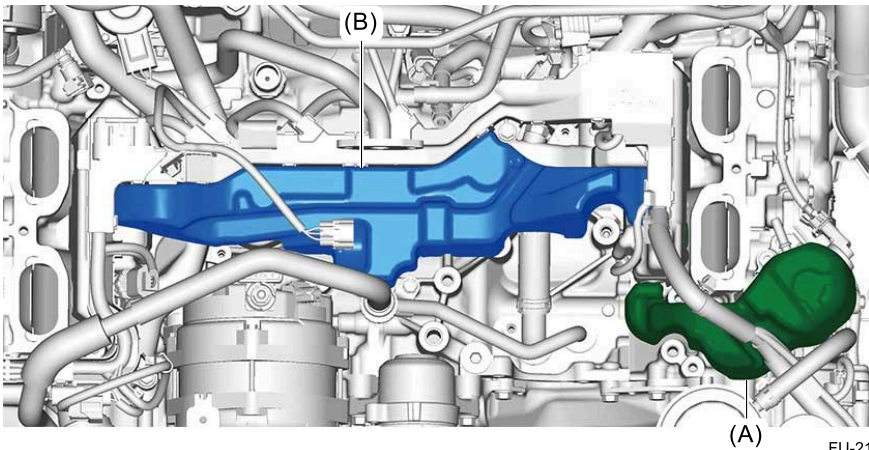
VB-HBU



FU-22298

4. Remove the fuel pump insulator (A) and fuel pipe insulator No. 3 (B).

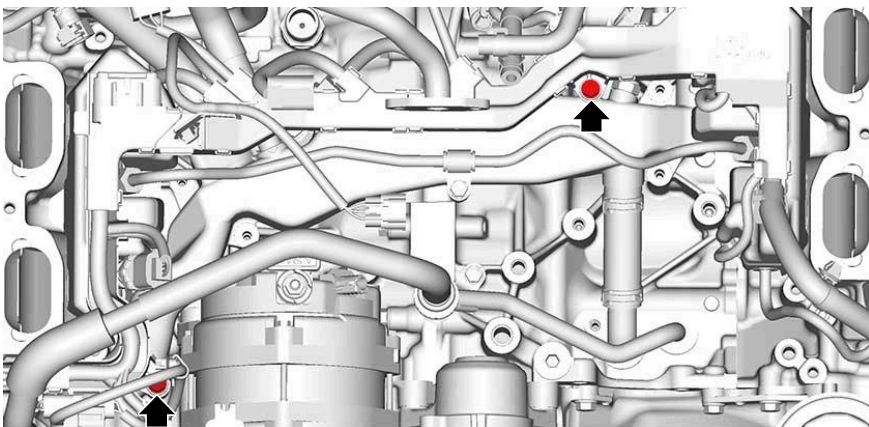
BWTXAU



FU-21446

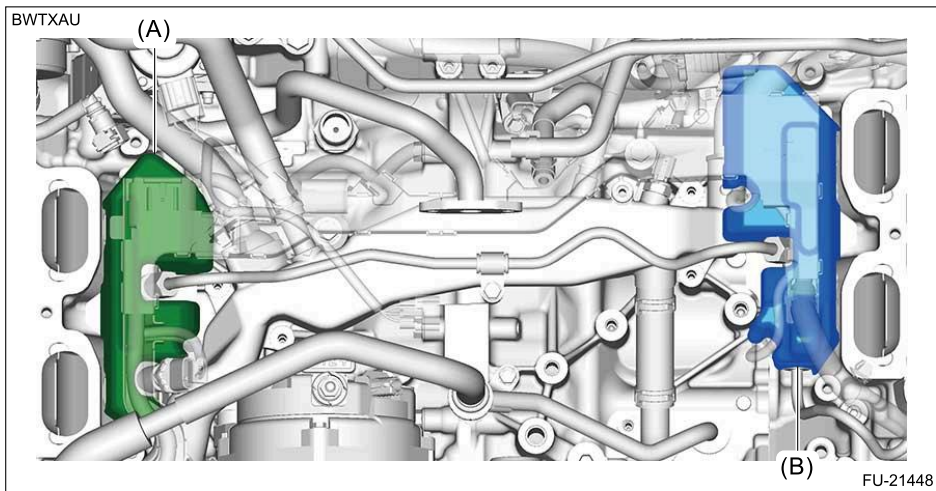
5. Remove the bolts securing the engine wiring harness.

BWTXAU

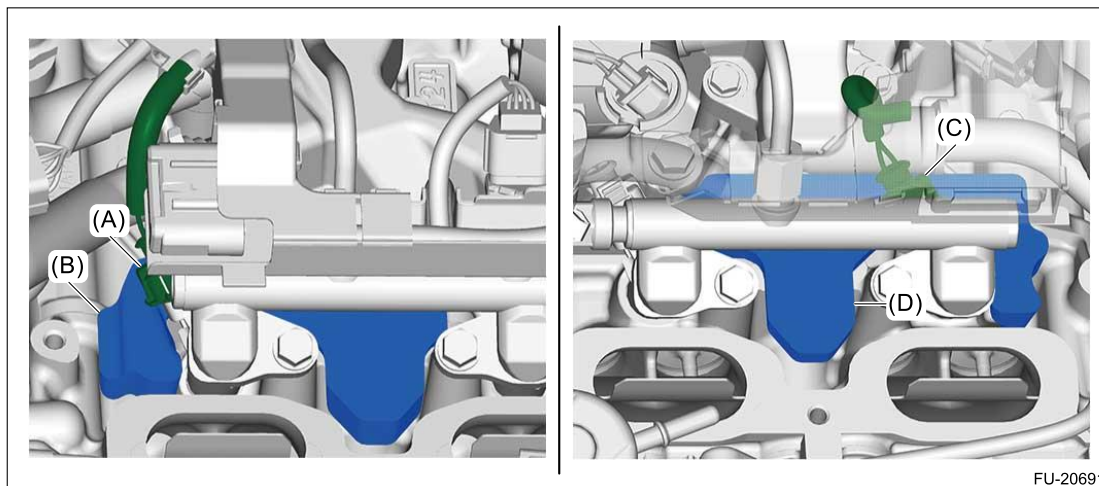


FU-21447

6. Remove the fuel pipe insulator No. 2 (A) and fuel pipe insulator No. 4 (B).



7. Disconnect the connector (A) from fuel injector #3, and remove the fuel pipe insulator No. 1 (B).
8. Disconnect the connector (C) from fuel injector #4, and remove the fuel pipe insulator No. 5 (D).



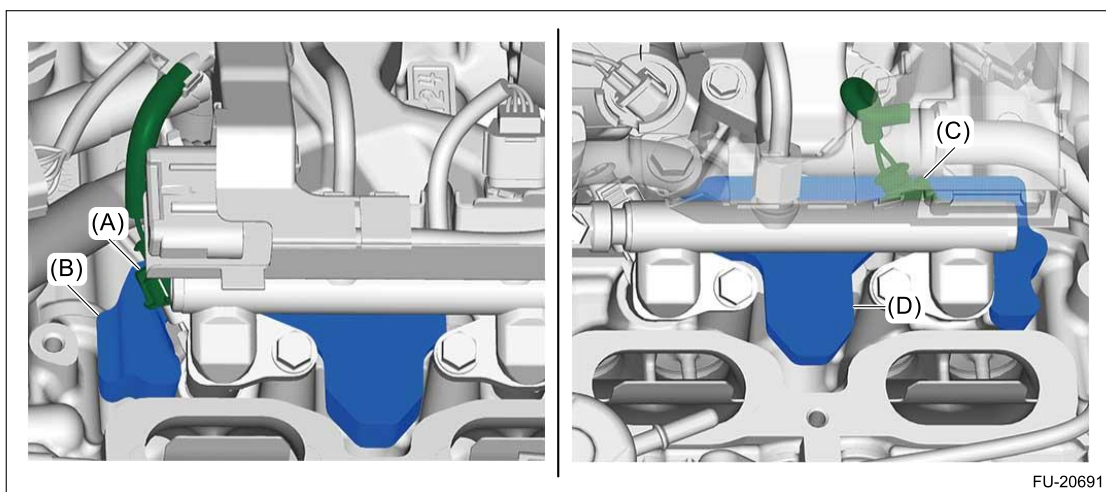
FUEL INJECTION (FUEL SYSTEMS)(H4DOTC) > Fuel Insulator

INSTALLATION

Caution:

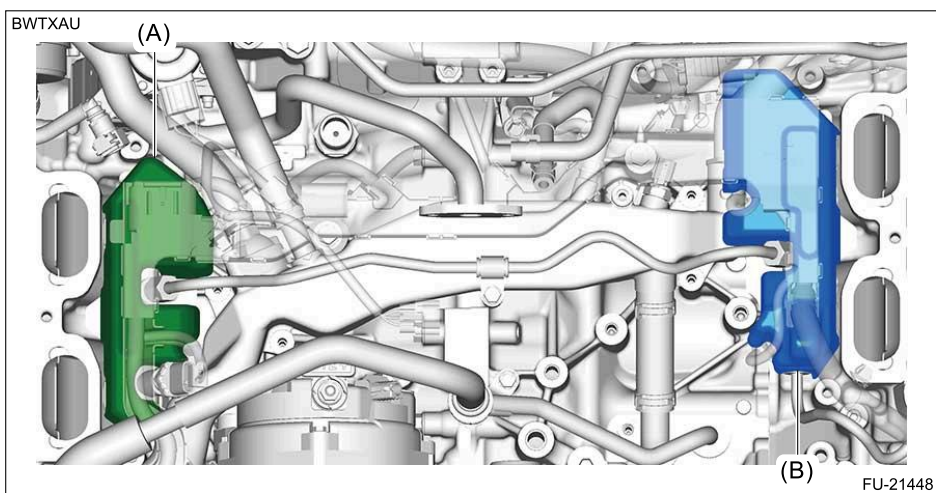
- If substantial amount of fuel or parts cleaner come into contact with the fuel insulator, replace it with a new one.
- If only small amount of fuel comes into contact with the fuel insulator, wait for the fuel to evaporate before installing it.

1. Install the fuel pipe insulator No. 1 (B), and connect the connector (A) to the fuel injector #3.
2. Install the fuel pipe insulator No. 5 (D), and connect the connector (C) to the fuel injector #4.



FU-20691

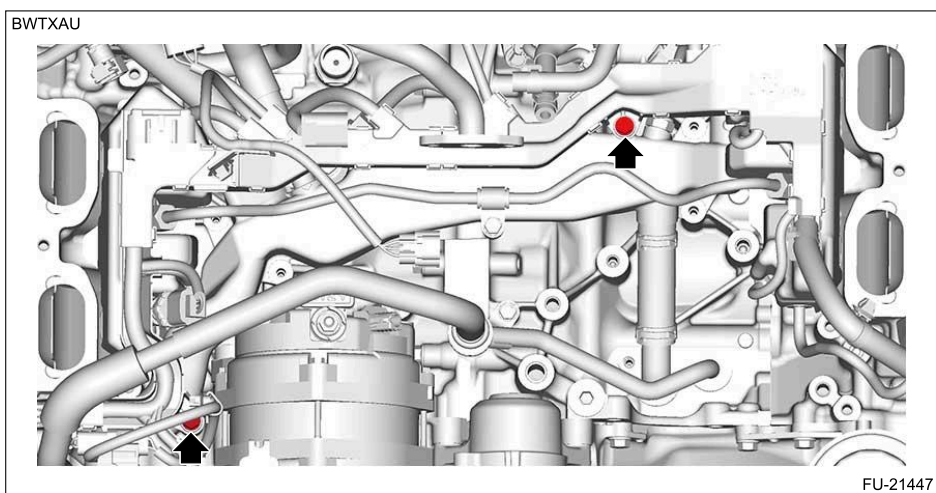
3. Install the fuel pipe insulator No. 2 (A) and fuel pipe insulator No. 4 (B).



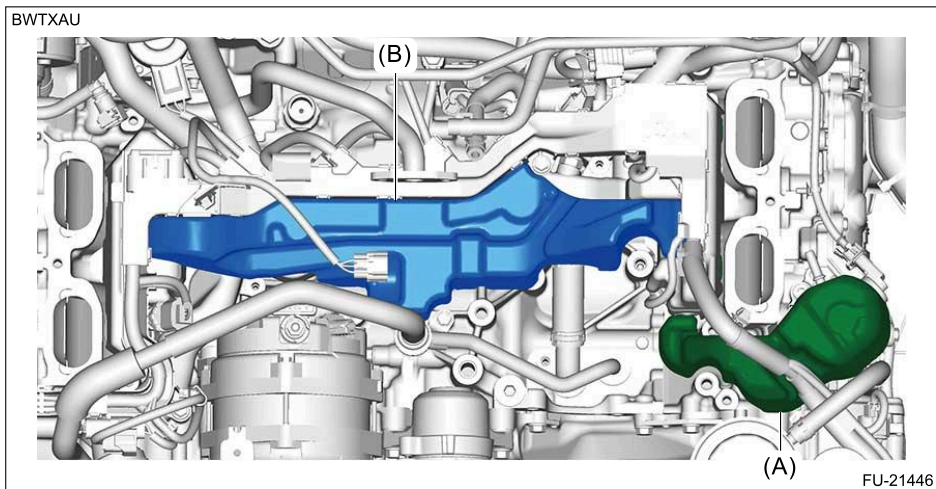
4. Secure the engine wiring harness with the bolts.

Tightening torque:

6.4 N·m (0.7 kgf-m, 4.7 ft-lb)



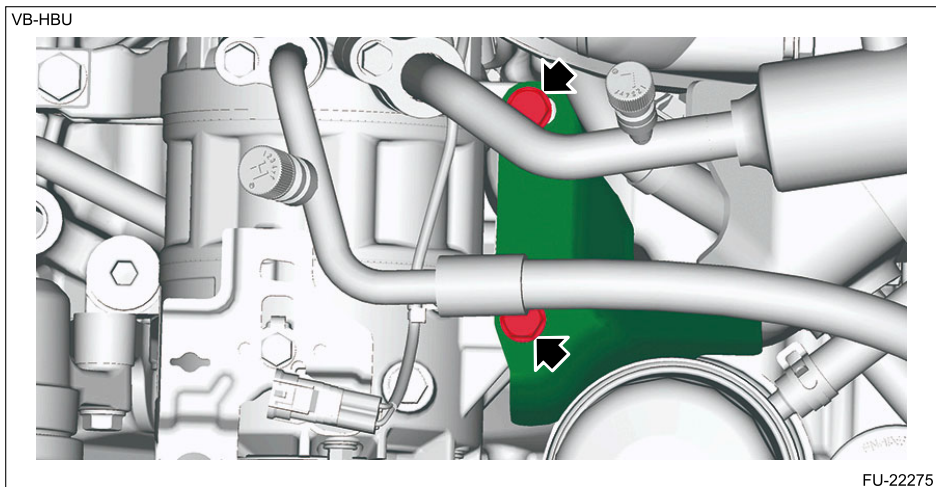
5. Install the fuel pump insulator (A) and fuel pipe insulator No. 3 (B).



6. Install the A/C compressor. [Ref. to AIR CONDITIONER>Compressor>INSTALLATION.](#)
7. Install the fuel pipe protector No. 1.

Tightening torque:

25 N·m (2.5 kgf·m, 18.4 ft·lb)



8. Install the intake manifold assembly. [Ref. to FUEL INJECTION \(FUEL SYSTEMS\)\(H4DOTC\)>Intake Manifold Assembly>INSTALLATION.](#)
9. Connect the ground terminal to battery sensor. [Ref. to REPAIR CONTENTS>NOTE > BATTERY.](#)
10. Check refrigerant leaks. [Ref. to AIR CONDITIONER>Refrigerant Leak Check>INSPECTION.](#)

FUEL INJECTION (FUEL SYSTEMS)(H4DOTC) > Fuel Insulator

INSPECTION

Check that the fuel insulator has no deformation, cracks or other damages.

REMOVAL



1. FUEL INJECTOR RH

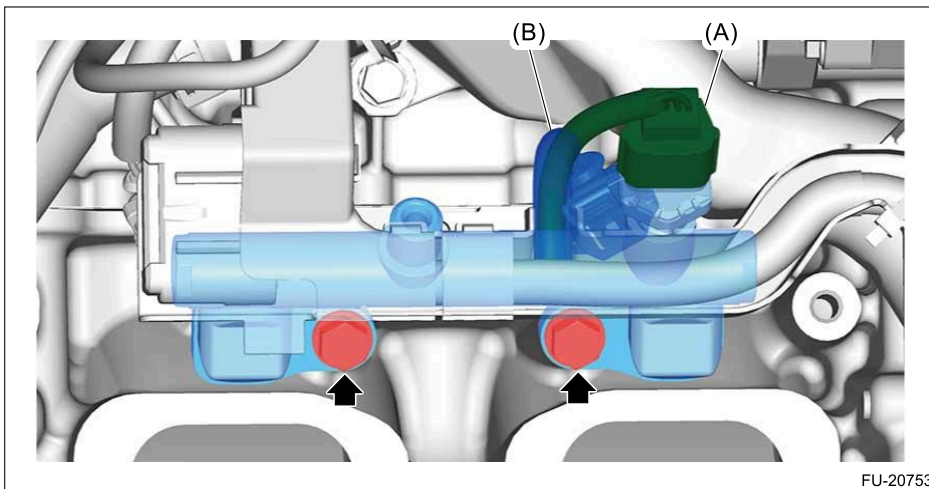
Caution:

- Be careful not to spill fuel.
- Catch the fuel from the pipes using a container or cloth.

1. Disconnect the ground terminal from battery sensor. Ref. to REPAIR CONTENTS>NOTE > BATTERY.
2. Remove the high-pressure fuel delivery pipe assembly. Ref. to FUEL INJECTION (FUEL SYSTEMS)(H4DOTC)>High Pressure Fuel Delivery Pipe>REMOVAL > HIGH-PRESSURE FUEL DELIVERY PIPE ASSEMBLY.
3. Disconnect the connector (A) from the fuel pressure sensor.
4. Disconnect the connector (B) from fuel injector #1, and remove the fuel injector pipe RH.

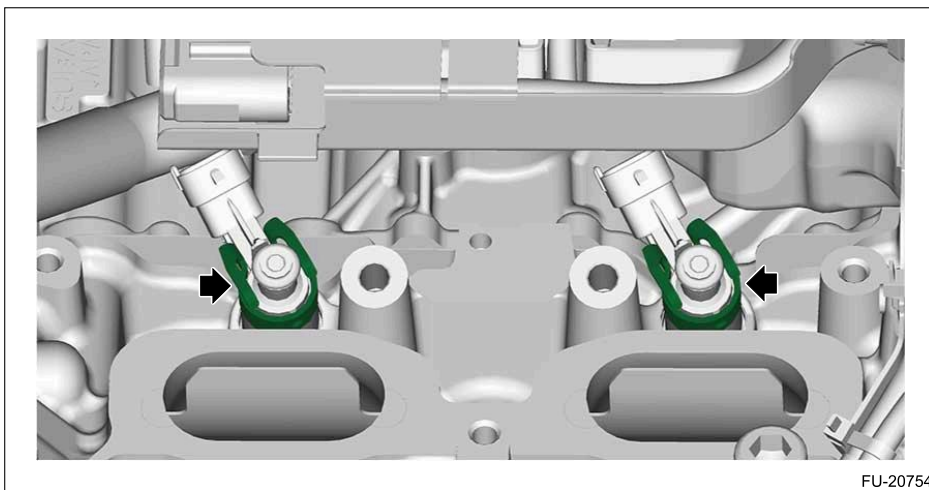
Caution:

Pull out the fuel injector pipe RH straight so that its seal surface is not damaged.



FU-20753

5. Remove the holder from the fuel injector assembly.



FU-20754

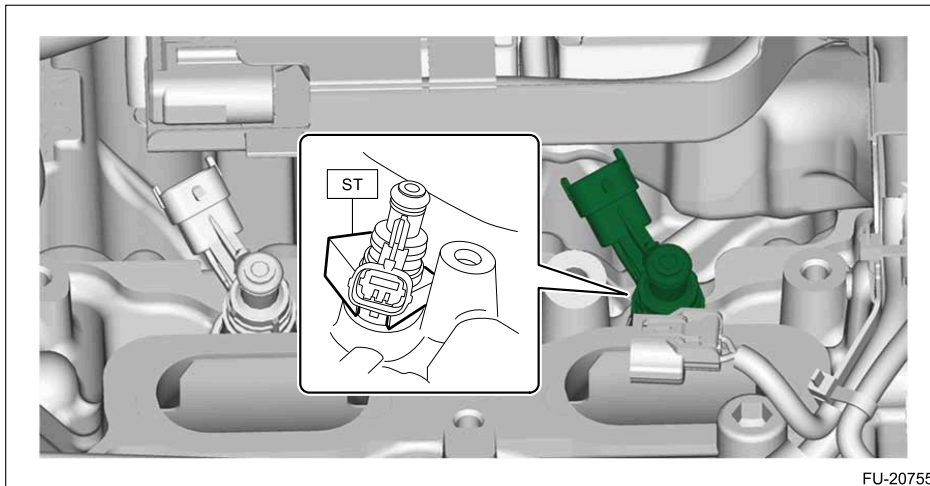
6. Using ST, remove the fuel injector assembly from the cylinder head.
(1) Set the ST to the fuel injector #1.

Note:

Do not use the ST adapter for the fuel injector #3.

Preparation tool:

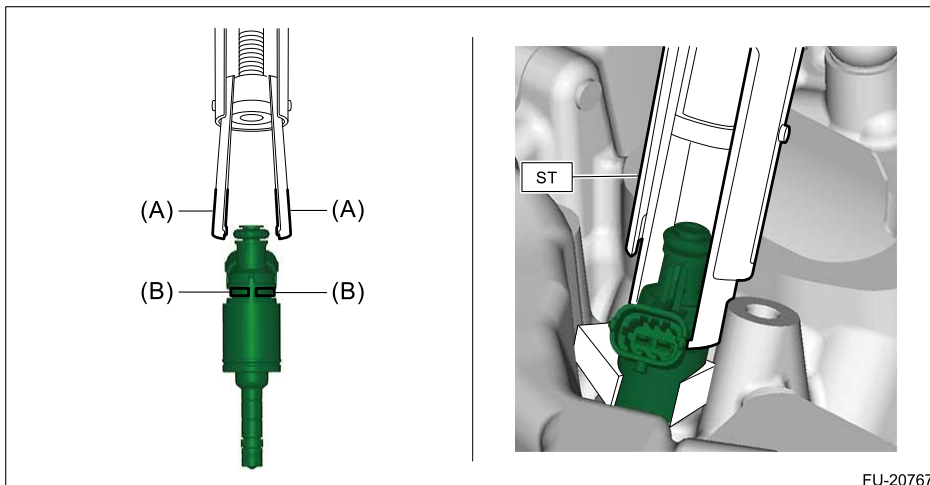
ST: ADAPTER R (18362AA060)



(2) Pinch the fuel injector groove (B) with the claw (A) of the ST.

Preparation tool:

ST: INJECTOR REMOVER (18356AA010)



(3) Press the ST to the cylinder head.

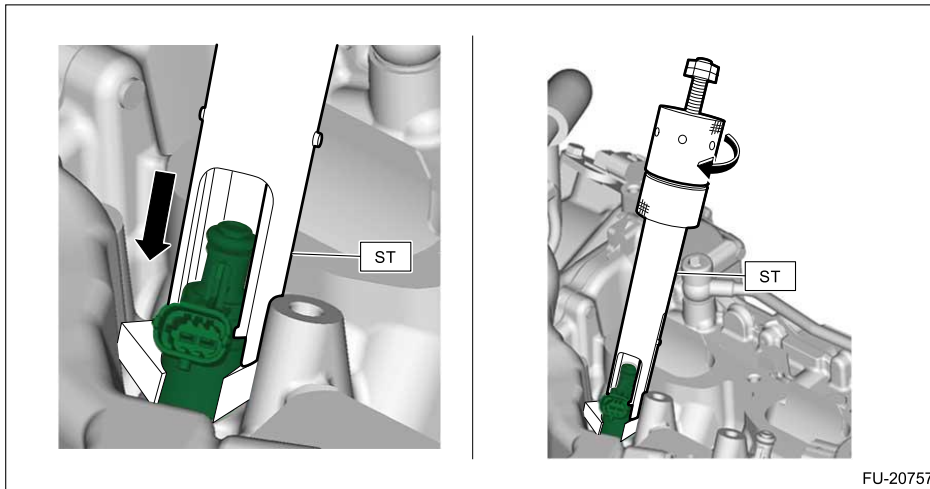
(4) Screw in the threaded section of the ST clockwise, and remove the fuel injector assembly from the cylinder head.

Caution:

- If the tip of the fuel injector assembly is hit or the assembly is dropped, replace the fuel injector assembly with a new part.
- Identify the removed fuel injector assembly with a tag etc. marked with the cylinder number.

Preparation tool:




ST: INJECTOR REMOVER (18356AA010)



2. FUEL INJECTOR LH

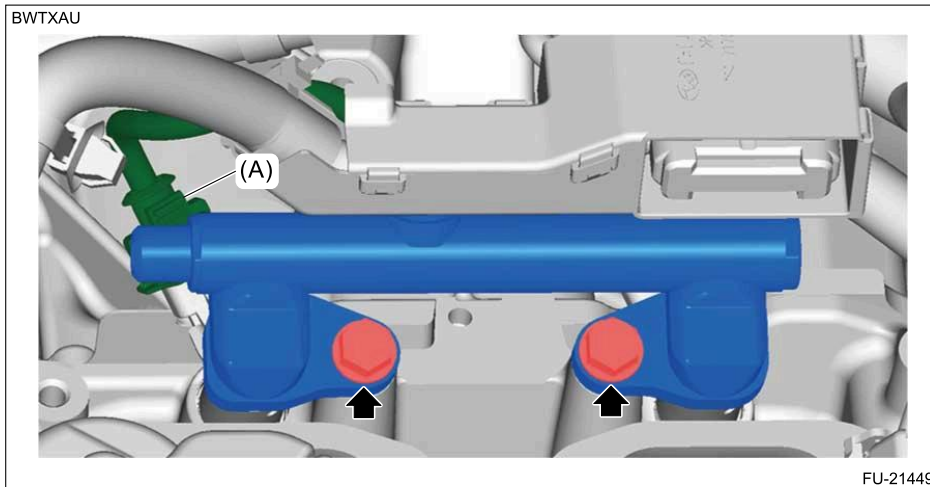
Caution:

- Be careful not to spill fuel.
- Catch the fuel from the pipes using a container or cloth.

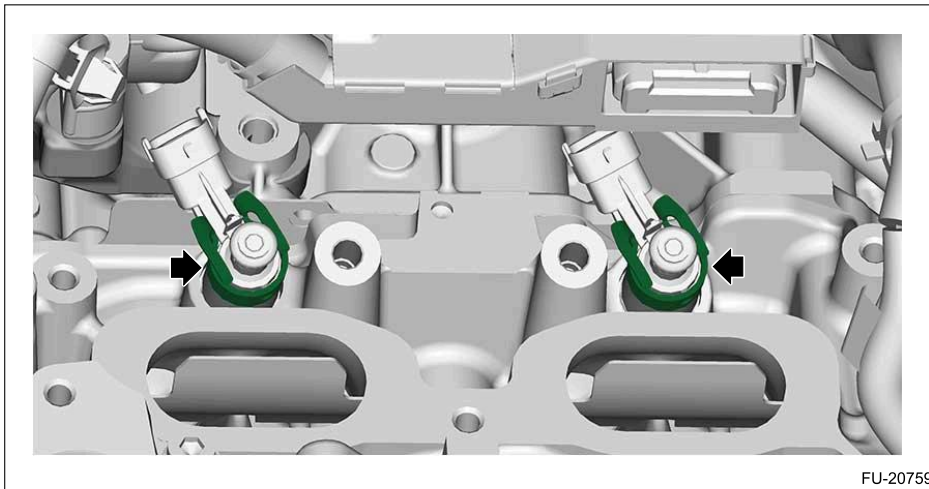
1. Disconnect the ground terminal from battery sensor.  [Ref. to REPAIR CONTENTS>NOTE > BATTERY.](#)
2. Remove the high-pressure fuel delivery pipe assembly.  [Ref. to FUEL INJECTION \(FUEL SYSTEMS\)\(H4DOTC\)>High Pressure Fuel Delivery Pipe>REMOVAL > HIGH-PRESSURE FUEL DELIVERY PIPE ASSEMBLY.](#)
3. Remove the high-pressure fuel delivery pipes.  [Ref. to FUEL INJECTION \(FUEL SYSTEMS\)\(H4DOTC\)>High Pressure Fuel Delivery Pipe>REMOVAL > HIGH-PRESSURE FUEL DELIVERY PIPE.](#)
4. Disconnect the connector (A) from fuel injector #2, and remove the fuel injector pipe LH.

Caution:

Pull out the fuel injector pipe LH straight so that its seal surface is not damaged.



5. Remove the holder from the fuel injector assembly.



6. Using ST, remove the fuel injector assembly from the cylinder head.

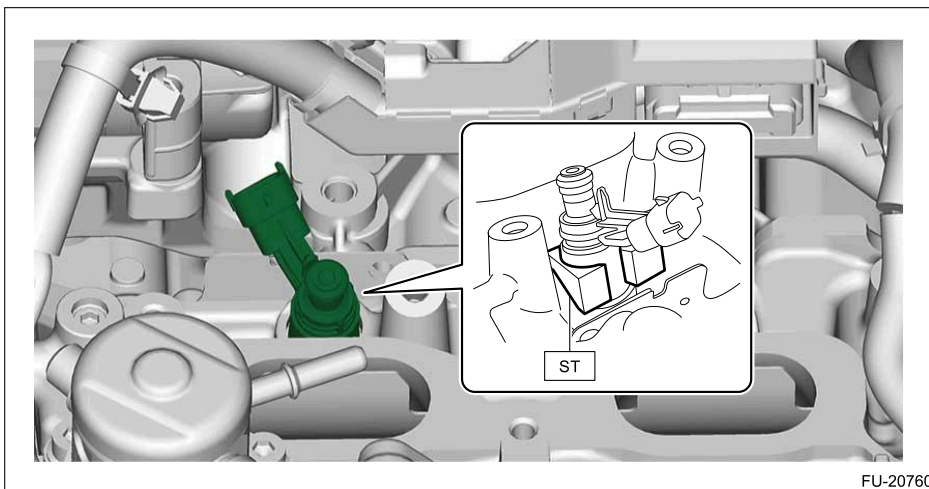
(1) Set the ST to the fuel injector #2.

Note:

Do not use the ST adapter for the fuel injector #4.

Preparation tool:

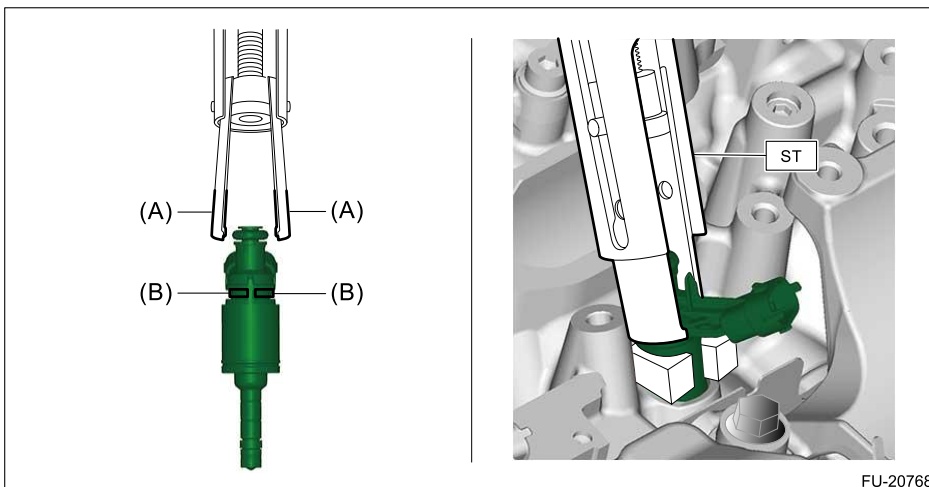
ST: ADAPTER L (18362AA070)



(2) Pinch the fuel injector groove (B) with the claw (A) of the ST.

Preparation tool:

ST: INJECTOR REMOVER (18356AA010)



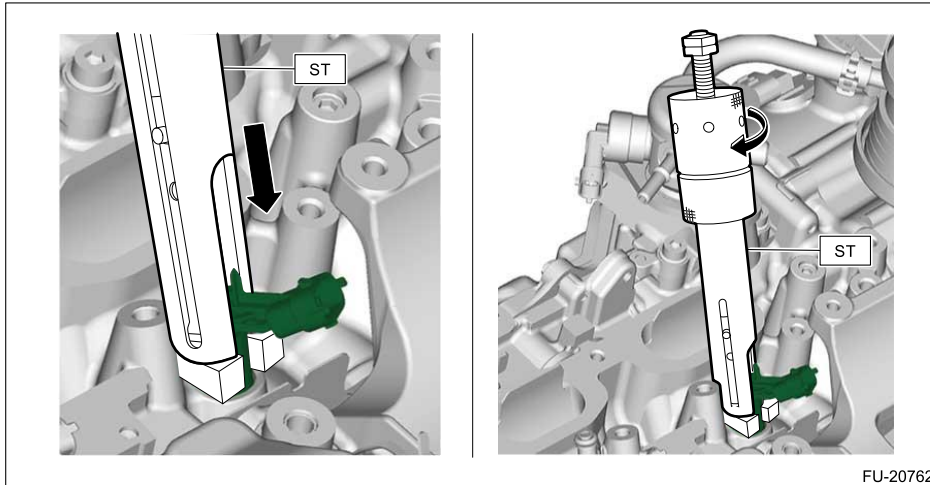
- (3) Press the ST to the cylinder head.
- (4) Screw in the threaded section of the ST clockwise, and remove the fuel injector assembly from the cylinder head.

Caution:

- If the tip of the fuel injector assembly is hit or the assembly is dropped, replace the fuel injector assembly with a new part.
- Identify the removed fuel injector assembly with a tag etc. marked with the cylinder number.

Preparation tool:

ST: INJECTOR REMOVER (18356AA010)




FUEL INJECTION (FUEL SYSTEMS)(H4DOTC) > Fuel Injector

INSTALLATION

1. FUEL INJECTOR RH

1. When reusing the fuel injector

(1) Replace fuel injector seal, decoupling, support disc and O-ring with new parts.  [Ref. to FUEL INJECTION \(FUEL SYSTEMS\)\(H4DOTC\)>Fuel Injector>REPLACEMENT.](#)

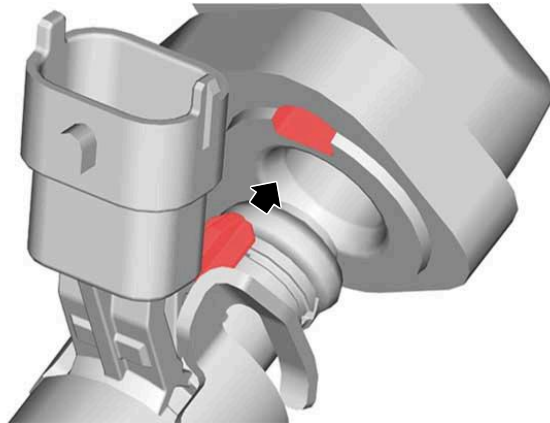
2. Set the holder to the fuel injector assembly, and install it straight to the fuel injector pipe RH.

Caution:

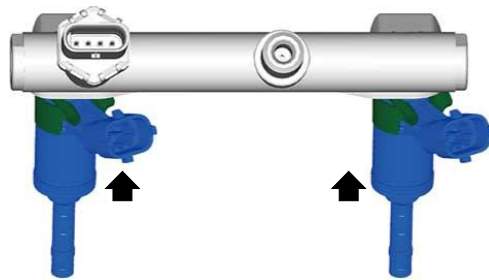
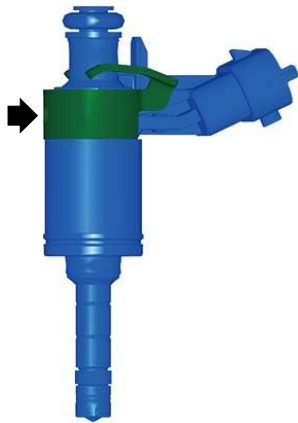
- Always use a new holder.
- Degrease inside of the fuel injector insertion hole of the fuel injector pipe.
- Check the inside of the fuel injector insertion hole of the fuel injector pipe for foreign materials or damage.
- Be careful not to allow gasoline to contact with the fuel injector seal and the inside of the mounting hole.
- Apply liquid paraffin to the O-ring and install it.
- Be careful not to twist the O-ring.
- To prevent damage to the O-ring, insert the part straight along the fuel injector insertion axis without tilting it and avoid removing and inserting the part again.
- To prevent the tip of the fuel injector from bending, do not apply force to the fuel injector tip.
- Check that the tip of the fuel injector has no bend or damage.
- Make sure there is no gap between the fuel injector pipe and the fuel injector holder.
- Make sure there is no gap between the fuel injector and the fuel injector holder.

Note:

Align the protrusion of the fuel injector with the fuel injector pipe RH hole.



FU-20761

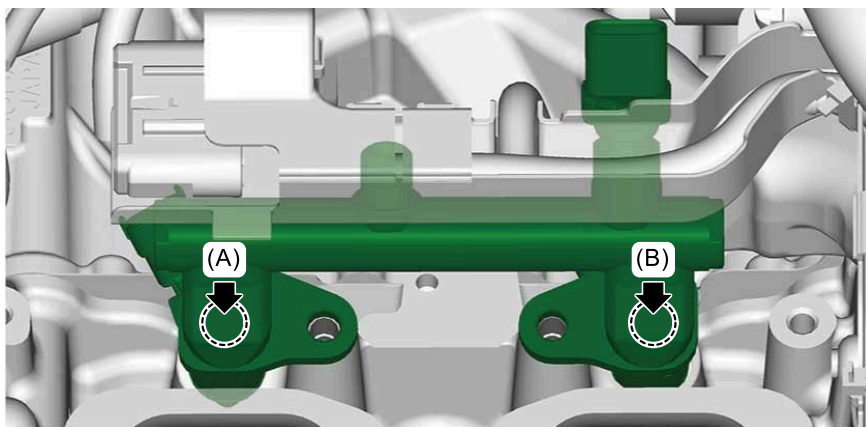


FU-20769

3. Insert the fuel injector pipe RH and fuel injector assembly as a single unit into the cylinder head, and align their positions. Then, evenly press the sections (A) and (B).

Caution:

- When installing, apply liquid paraffin to the fuel injector seal.
- In order to prevent damaging the O-ring, do not install the fuel injector pipe and fuel injector by tilting them toward the cylinder head.



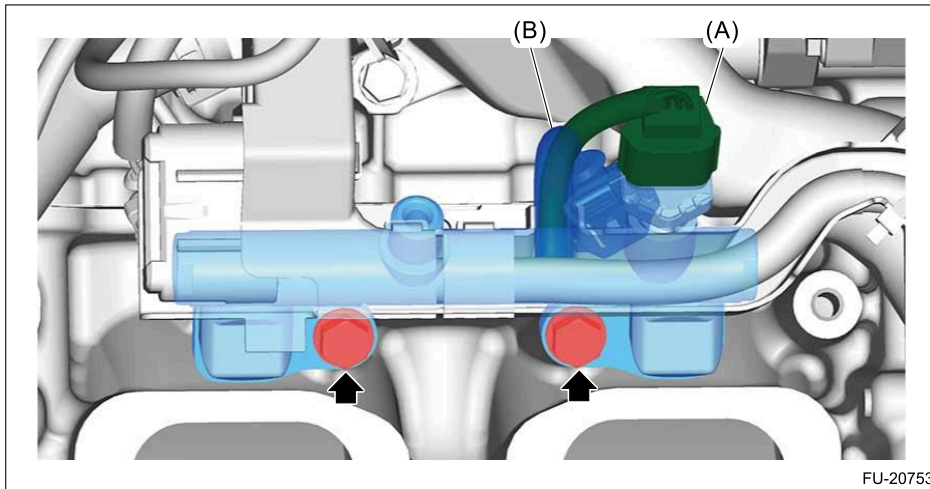
FU-20763

4. Tighten the bolt on fuel injector pipe RH, and connect the connector (B) to the fuel injector #1.

Tightening torque:

19 N·m (1.9 kgf-m, 14.0 ft-lb)

5. Connect connector (A) to the fuel pressure sensor.



6. Install the high-pressure fuel delivery pipe assembly. [🔗 Ref. to FUEL INJECTION \(FUEL SYSTEMS\)\(H4DOTC\)>High Pressure Fuel Delivery Pipe>INSTALLATION > HIGH-PRESSURE FUEL DELIVERY PIPE ASSEMBLY.](#)

7. Connect the ground terminal to battery sensor. [🔗 Ref. to REPAIR CONTENTS>NOTE > BATTERY.](#)

2. FUEL INJECTOR LH

1. When reusing the fuel injector

(1) Replace fuel injector seal, decoupling, support disc and O-ring with new parts. [🔗 Ref. to FUEL INJECTION \(FUEL SYSTEMS\)\(H4DOTC\)>Fuel Injector>REPLACEMENT.](#)

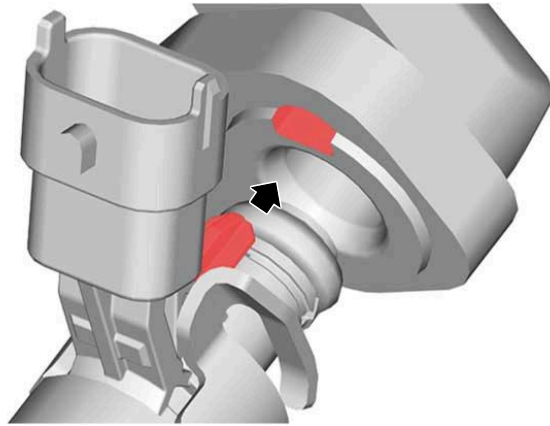
2. Set the holder to the fuel injector assembly, and install it straight to the fuel injector pipe LH.

Caution:

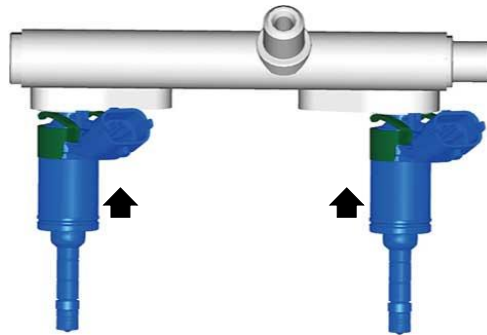
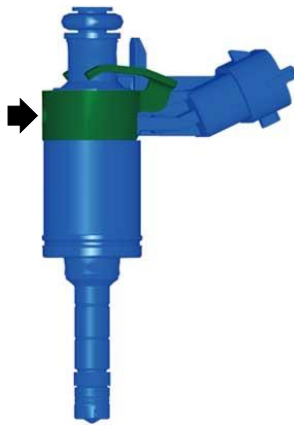
- Always use a new holder.
- Degrease inside of the fuel injector insertion hole of the fuel injector pipe.
- Check the inside of the fuel injector insertion hole of the fuel injector pipe for foreign materials or damage.
- Be careful not to allow gasoline to contact with the fuel injector seal and the inside of the mounting hole.
- Apply liquid paraffin to the O-ring and install it.
- Be careful not to twist the O-ring.
- To prevent damage to the O-ring, insert the part straight along the fuel injector insertion axis without tilting it and avoid removing and inserting the part again.
- To prevent the tip of the fuel injector from bending, do not apply force to the fuel injector tip.
- Check that the tip of the fuel injector has no bend or damage.
- Make sure there is no gap between the fuel injector pipe and the fuel injector holder.
- Make sure there is no gap between the fuel injector and the fuel injector holder.

Note:

Align the protrusion of the fuel injector with the fuel injector pipe LH hole.



FU-20761



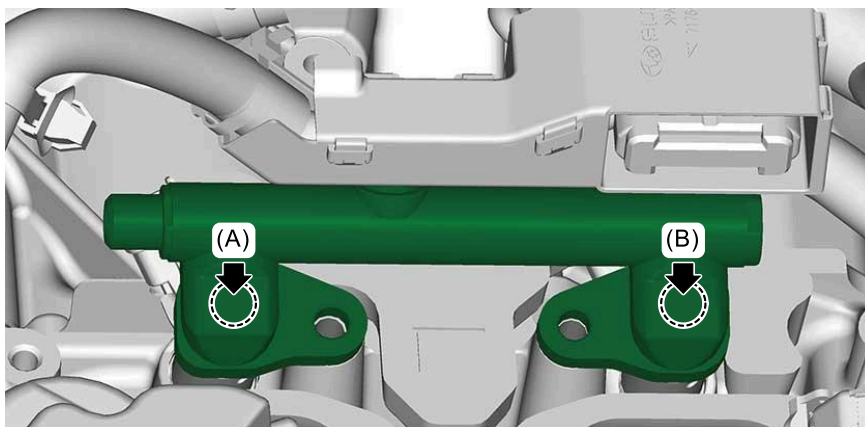
FU-20770

3. Insert the fuel injector pipe LH and fuel injector assembly as a single unit into the cylinder head, and align their positions. Then, evenly press the sections (A) and (B).

Caution:

- When installing, apply liquid paraffin to the fuel injector seal.
- In order to prevent damaging the O-ring, do not install the fuel injector pipe and fuel injector by tilting them toward the cylinder head.

BWTXAU

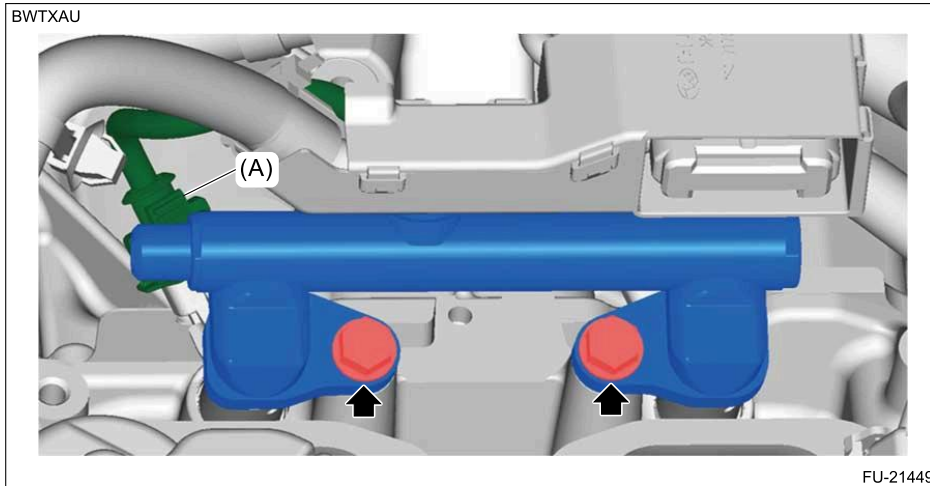





FU-21450

4. Tighten the bolt on fuel injector pipe LH, and connect the connector (A) to the fuel injector #2.

Tightening torque:

19 N·m (1.9 kgf-m, 14.0 ft-lb)

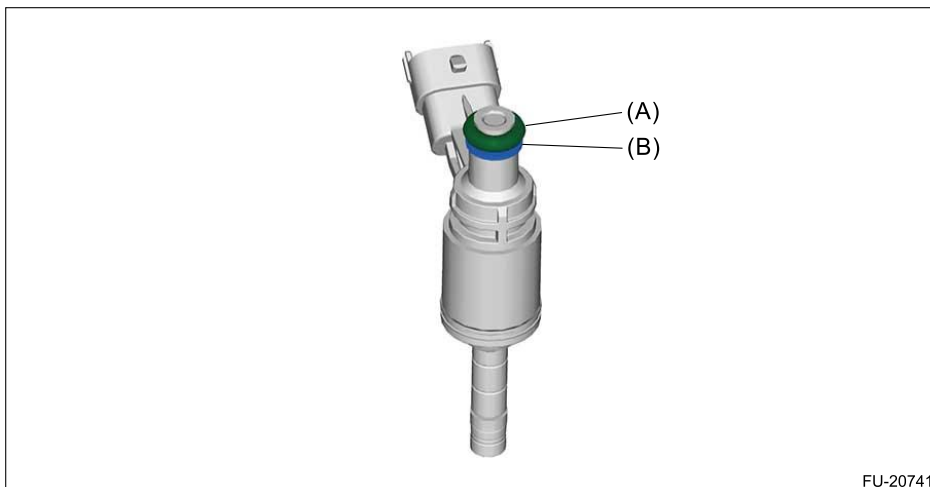


5. Install the high-pressure fuel delivery pipe assembly.  Ref. to [FUEL INJECTION \(FUEL SYSTEMS\)\(H4DOTC\)>High Pressure Fuel Delivery Pipe>INSTALLATION > HIGH-PRESSURE FUEL DELIVERY PIPE ASSEMBLY](#).
6. Install the high-pressure fuel delivery pipe.  Ref. to [FUEL INJECTION \(FUEL SYSTEMS\)\(H4DOTC\)>High Pressure Fuel Delivery Pipe>INSTALLATION > HIGH-PRESSURE FUEL DELIVERY PIPE](#).
7. Connect the ground terminal to battery sensor.  Ref. to [REPAIR CONTENTS>NOTE > BATTERY](#).

FUEL INJECTION (FUEL SYSTEMS)(H4DOTC) > Fuel Injector

REPLACEMENT

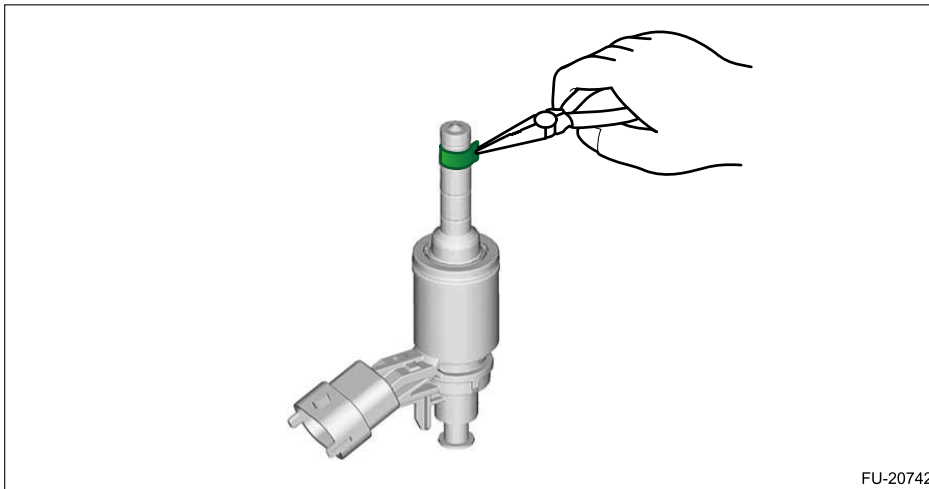
1. Remove the O-ring (A) and support disc (B).



2. Gradually expand the fuel injector seal and remove the fuel injector seal.

Caution:

- Be careful not to apply too much force when pinching the fuel injector seal, or the fuel injector groove may be damaged.
- If the tip of the fuel injector assembly is hit or the assembly is dropped, replace the fuel injector assembly with a new one.

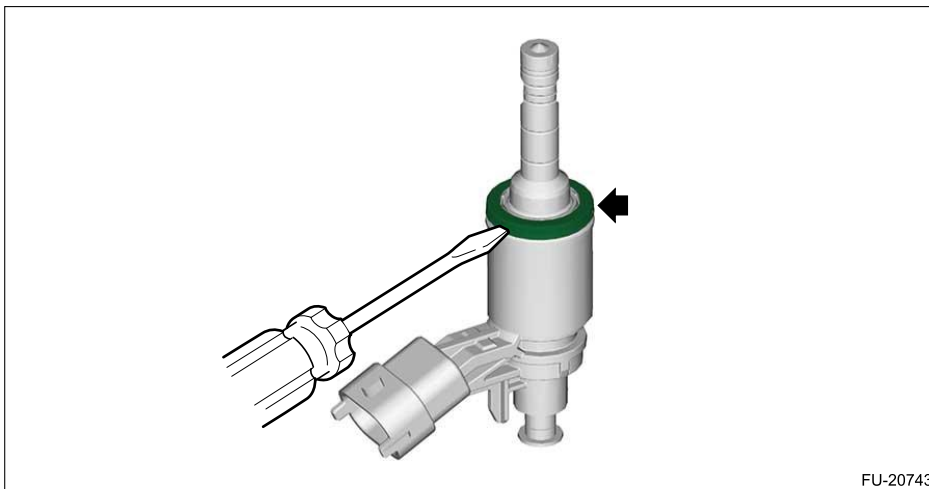


FU-20742

3. Remove the decoupling.

Note:

Perform this procedure only when required.



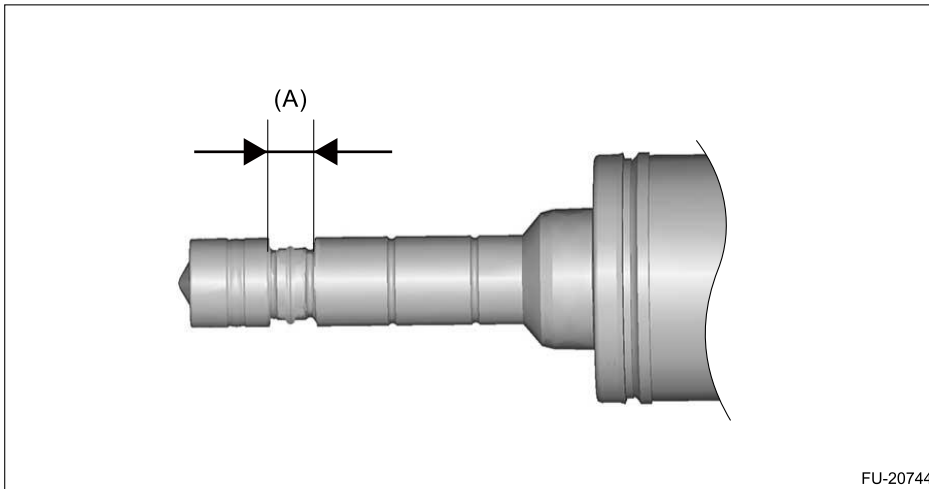
FU-20743

4. Install the fuel injector seal.

(1) Remove carbon from area (A) shown in the figure (fuel injector seal groove).

Caution:

- **Do not attempt to clean the tip.**
- **Do not use a wire-brush.**
- **If the tip of the fuel injector assembly is hit or the assembly is dropped, replace the fuel injector assembly with a new one.**



(2) Set the ST1 on the end of fuel injector, and install new fuel injector seal (A) on the ST1.

Caution:

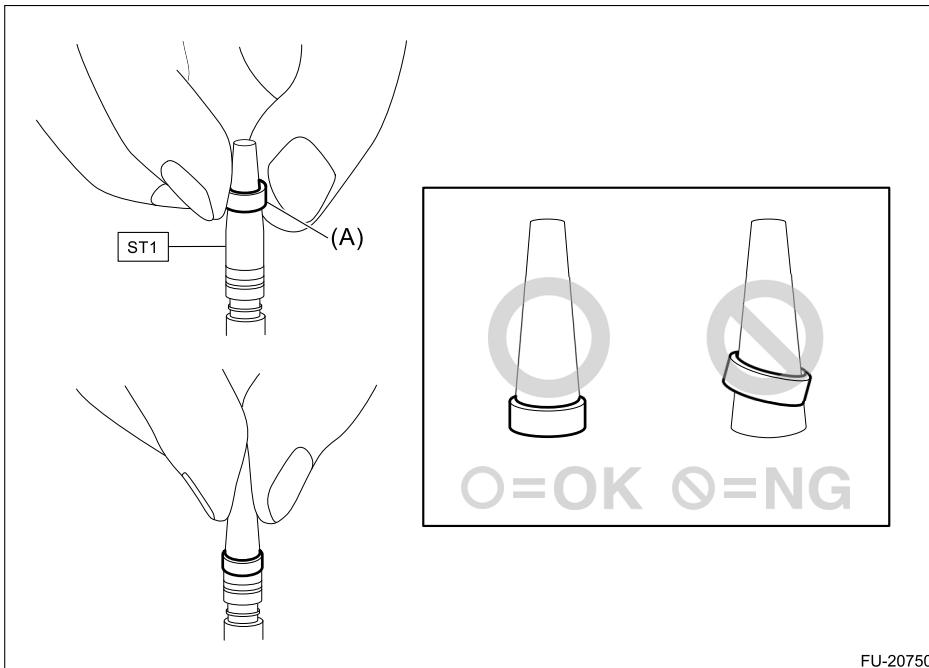
When setting the fuel injector seal on the ST1, be careful not to set it obliquely, or the seal is stretched and become hard to be fixed.

Note:

- Apply liquid paraffin to the fuel injector seal and fuel injector groove.
- Do not let liquid paraffin contact inside the fuel injector and the port located at the tip end of the fuel injector.

Preparation tool:

ST1: GUIDE (18271AA030)



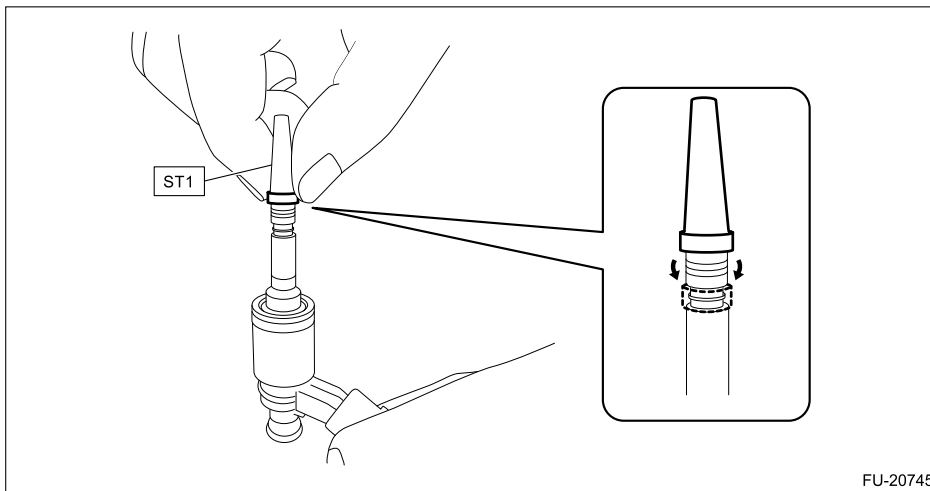
(3) Use fingers to push down on the fuel injector seal installed to the ST1, and install it to the fuel injector groove as shown in the figure.

Caution:

Make sure that the entire perimeter of the fuel injector seal fit in the groove.

Preparation tool:

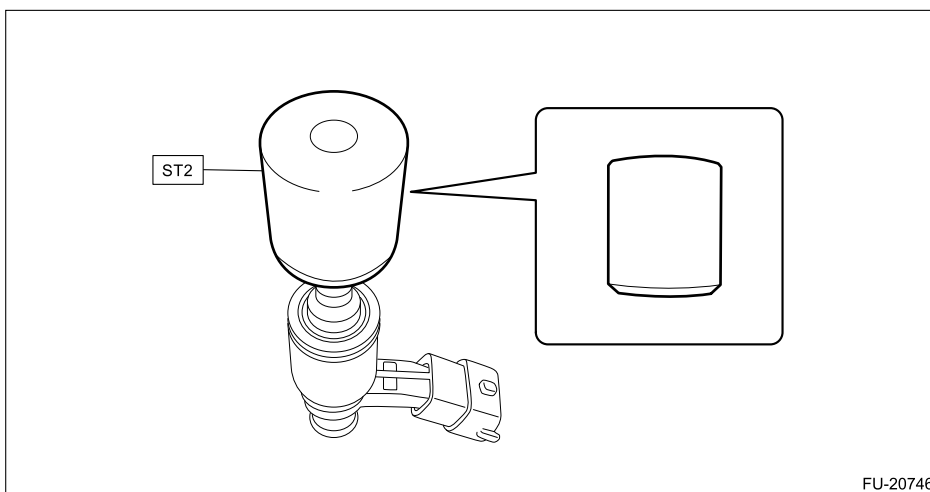
ST1: GUIDE (18271AA030)



(4) Set the ST2 on the fuel injector as shown in the figure.

Preparation tool:

ST2: ADJUSTER (18271AA040)



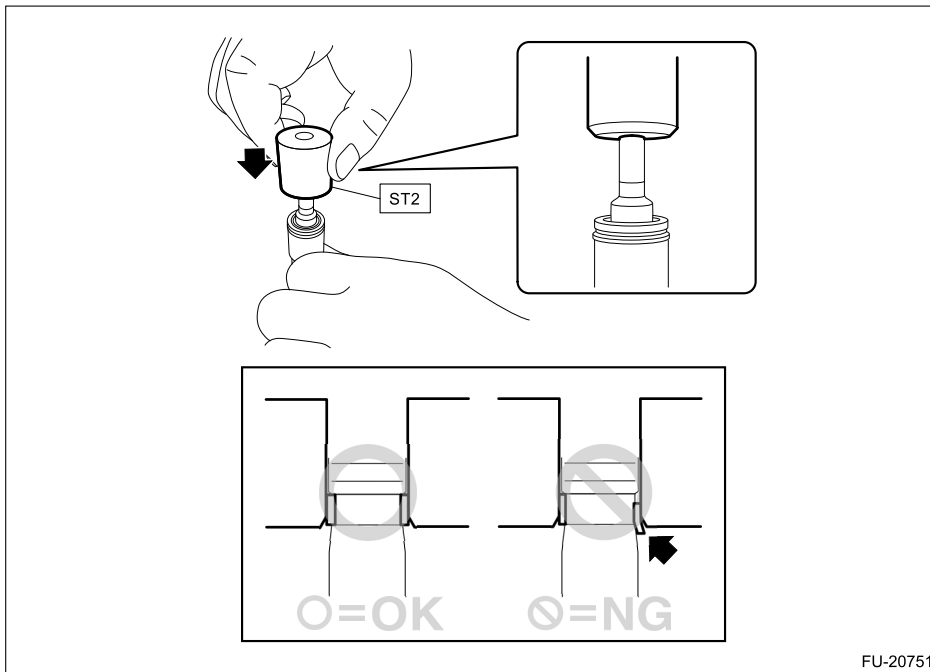
(5) Slowly press the ST2 downward in the direction of arrow and seat the fuel injector seal into the fuel injector groove.

Caution:

Be careful not to let the fuel injector seal get caught in the ST2 and the fuel injector groove. If it gets caught, repeat the procedure from the step (2).

Preparation tool:

ST2: ADJUSTER (18271AA040)



- (6) Further press the ST2 downward and hold it for 5 seconds or more after the ST2 come all the way to the end, and then rectify the fuel injector seal.

Caution:

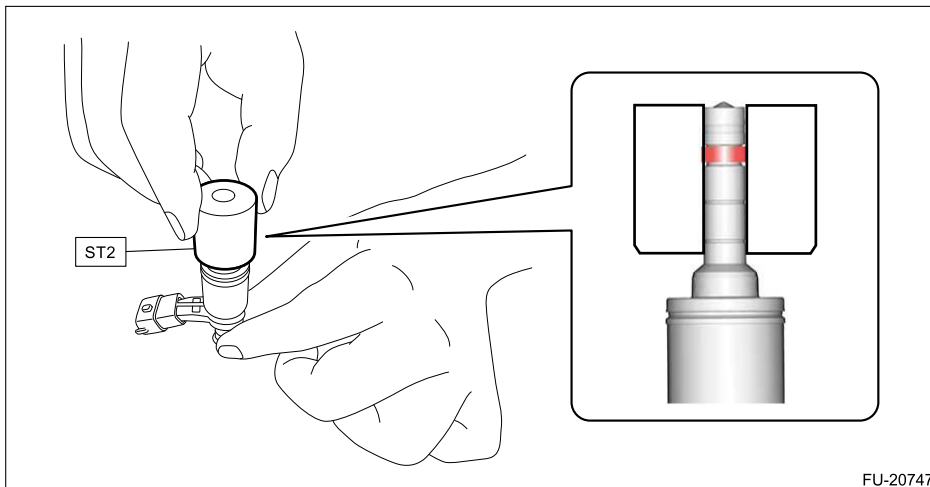
Be careful not to let the fuel injector seal get caught in the ST2 and the fuel injector groove. If it gets caught, repeat the procedure from the step (2).

Note:

If it is hard to press down the ST2, try to slowly press down the ST2 by shaking it side to side.

Preparation tool:

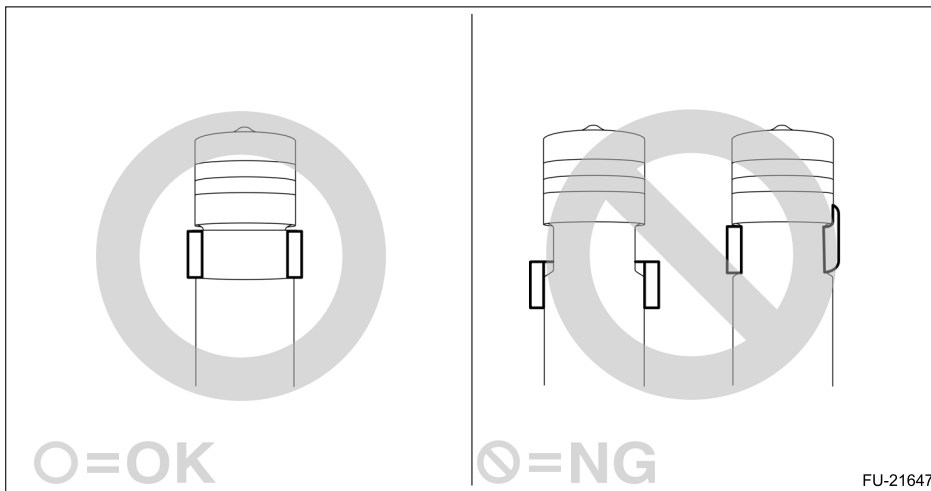
ST2: ADJUSTER (18271AA040)



- (7) After installing the fuel injector seal, check the seal for scratches, crushed area, or dislocation from the groove.

Caution:

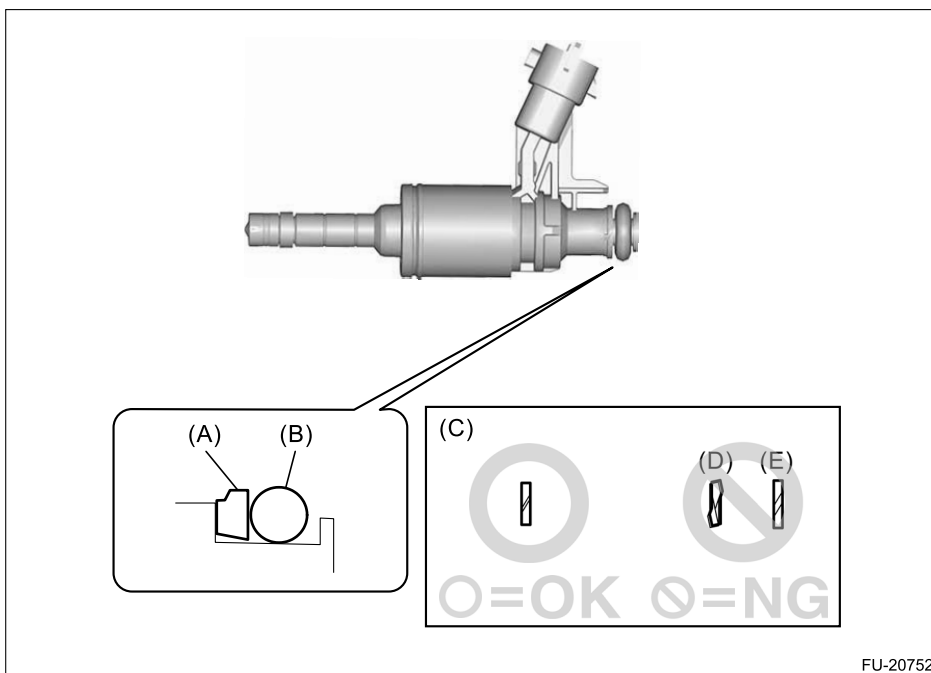
If scratches, crushed area, or dislocation from the groove is found in the fuel injector seal, repeat the procedure from the step (2).



5. Install the new support disc and new O-ring.

Caution:

- If the tip of the fuel injector assembly is hit or the assembly is dropped, replace the fuel injector assembly with a new one.
- Check the O-ring seal groove of the fuel injector for foreign materials or damage.
- Be careful of the orientation of the support disc.
- Make sure that the installation order of the support disc and O-ring is correct.
- There should be no expansion or ride over at the support disc gap as shown in the figure.



(A) Support disc

(B) O-ring

(C) Support disc gap

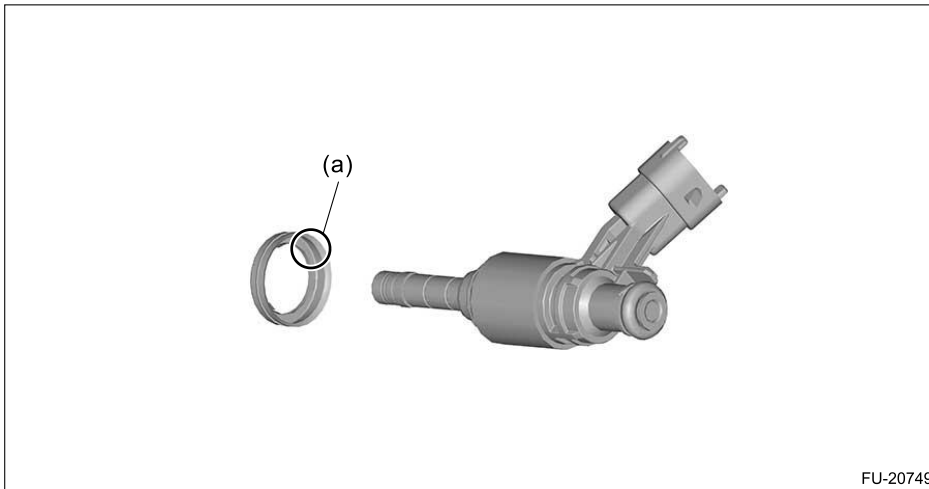
(D) Ride over

(E) Expansion

6. Install a new decoupling.

Caution:

- If the tip of the fuel injector assembly is hit or the assembly is dropped, replace the fuel injector assembly with a new one.
- When installing the decoupling, the groove side (a) should face toward the fuel injector.



7. After assembling the parts, check that there is no foreign materials or damage on the fuel injector seal.

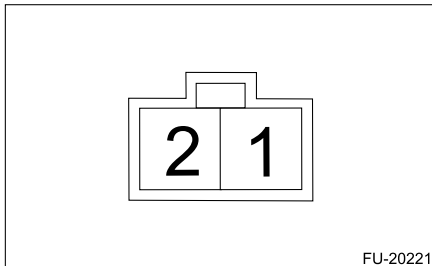
FUEL INJECTION (FUEL SYSTEMS)(H4DOTC) > Fuel Injector

INSPECTION

1. Check that the fuel injector has no deformation, cracks or other damages.
2. Measure the resistance between fuel injector terminals.

Note:

This inspection can be used for judgment on short circuit or open circuit among the causes of faulty operation.



Terminal No.	Standard
1 – 2	Approx. 1.5 Ω (when 23°C (73°F))

FUEL INJECTION (FUEL SYSTEMS)(H4DOTC) > Fuel Pressure Sensor

REMOVAL



Caution:

- Be careful not to spill fuel.
- Catch the fuel from the pipes using a container or cloth.

1. Disconnect the ground terminal from battery sensor. [Ref. to REPAIR CONTENTS>NOTE > BATTERY.](#)
2. Remove the intake manifold assembly. [Ref. to FUEL INJECTION \(FUEL SYSTEMS\)\(H4DOTC\)>Intake Manifold Assembly>REMOVAL.](#)
3. Remove the fuel injector RH. [Ref. to FUEL INJECTION \(FUEL SYSTEMS\)\(H4DOTC\)>Fuel Injector>REMOVAL > FUEL INJECTOR RH.](#)

Note:

When replacing the fuel pressure sensor or fuel injector pipe RH, it is not necessary to remove the fuel pressure sensor from the fuel injector pipe RH as both parts are replaced with new parts.

FUEL INJECTION (FUEL SYSTEMS)(H4DOTC) > Fuel Pressure Sensor

INSTALLATION

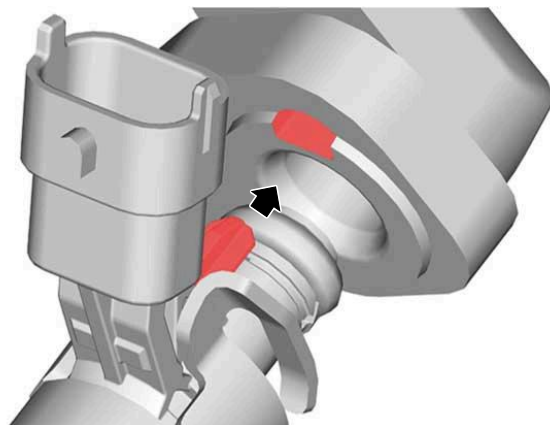
1. Replace fuel injector seal, decoupling, support disc and O-ring with new parts. [Ref. to FUEL INJECTION \(FUEL SYSTEMS\)\(H4DOTC\)>Fuel Injector>REPLACEMENT.](#)
2. Set the holder to the fuel injector, and install it straight to the fuel injector pipe RH.

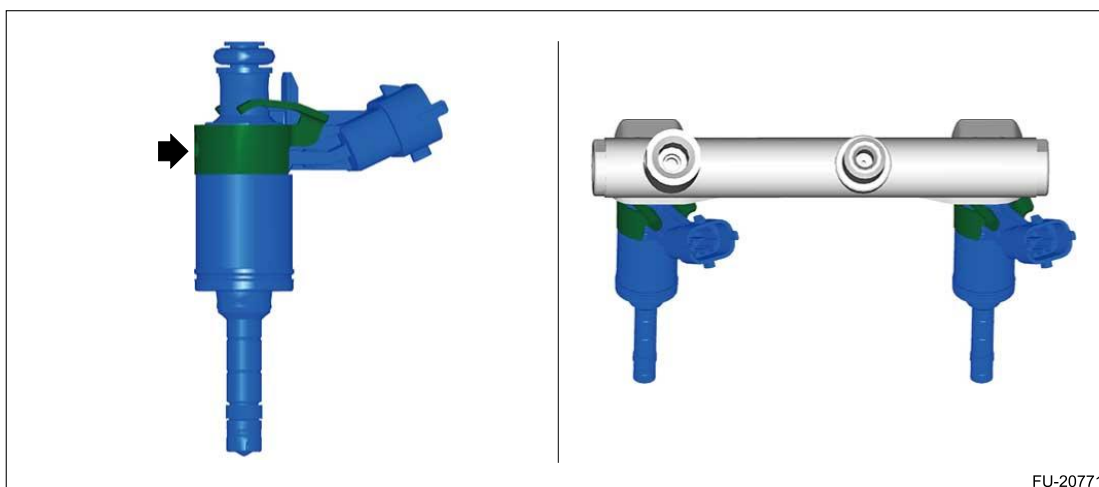
Caution:

- Always use a new holder and fuel injector pipe RH.
- Degrease inside of the fuel injector insertion hole of the fuel injector pipe.
- Check the inside of the fuel injector insertion hole of the fuel injector pipe for foreign materials or damage.
- Be careful not to allow gasoline to contact with the fuel injector seal and the inside of the mounting hole.
- Apply liquid paraffin to the O-ring and install it.
- Be careful not to twist the O-ring.
- To prevent damage to the O-ring, insert the part straight along the fuel injector insertion axis without tilting it and avoid removing and inserting the part again.
- To prevent the tip of the fuel injector from bending, do not apply force to the fuel injector tip.
- Check that the tip of the fuel injector has no bend or damage.
- Make sure there is no gap between the fuel injector pipe and the fuel injector holder.
- Make sure there is no gap between the fuel injector and the fuel injector holder.

Note:

Align the protrusion of the fuel injector with the fuel injector pipe RH hole.



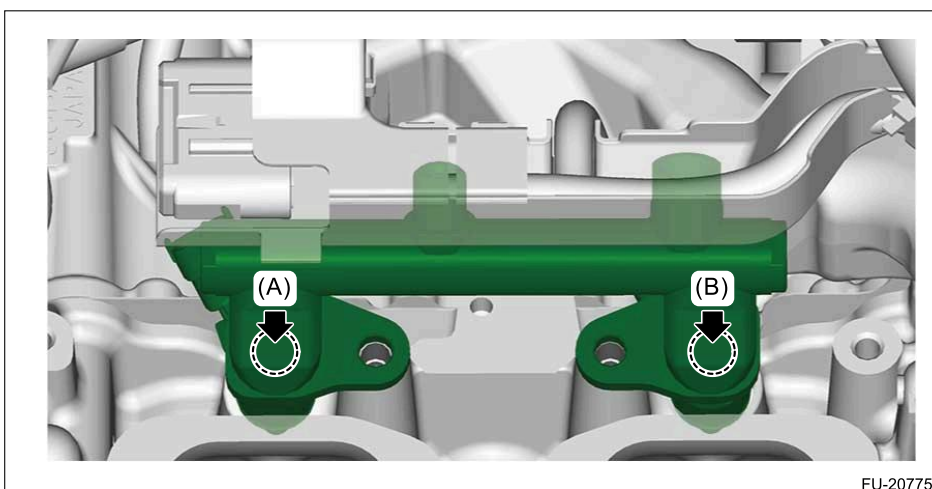


FU-20771

3. Insert the fuel injector pipe RH and fuel injector as a single unit into the cylinder head, and align their positions. Then, evenly press the sections (A) and (B).

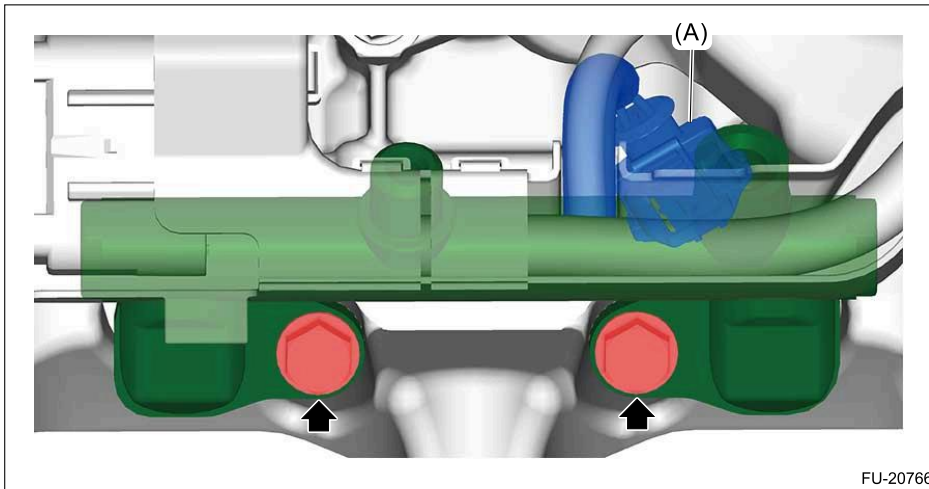
Caution:

- When installing, apply liquid paraffin to the fuel injector seal.
- In order to prevent damaging the O-ring, do not install the fuel injector pipe and fuel injector by tilting them toward the cylinder head.



FU-20775

4. Tighten the fuel injector pipe RH.
Tightening torque:
 19 N·m (1.9 kgf-m, 14.0 ft-lb)
5. Connect the connector (A) to fuel injector #1.



6. Temporarily tighten the fuel pressure sensor to the fuel injector pipe RH until it cannot be turned by hand.

Caution:

Always use a new fuel pressure sensor.

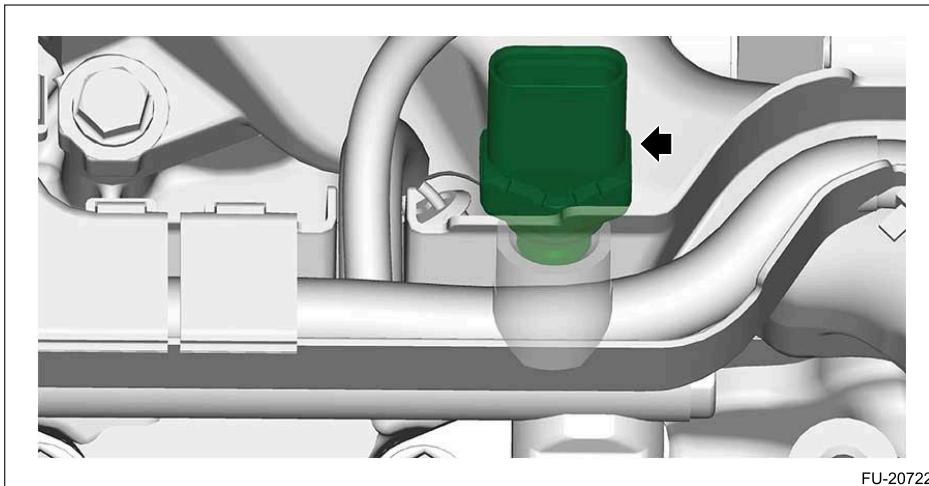
7. Tighten the fuel pressure sensor.

Caution:

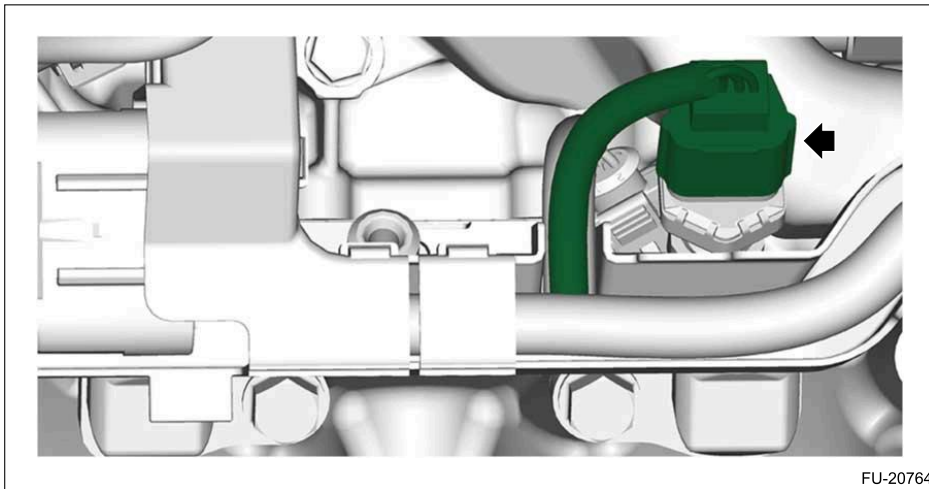
- Be careful not to spill oil on the screw sections of the fuel pressure sensor and the fuel injector pipe RH.
- Be careful not to let foreign matter enter into the fuel pressure sensor during installation.
- The sensor should be installed perpendicularly to the fuel pressure sensor's threaded hole of the fuel injector pipe RH, and tightened to the specified torque.
- Do not recheck the tightening torque after tightening the fuel pressure sensor with specified torque.



Tightening torque:

46 N·m (4.7 kgf-m, 33.9 ft-lb)



8. Connect connector to the fuel pressure sensor.



- 9.** Install the high-pressure fuel delivery pipe assembly.  [Ref. to FUEL INJECTION \(FUEL SYSTEMS\)\(H4DOTC\)>High Pressure Fuel Delivery Pipe>INSTALLATION > HIGH-PRESSURE FUEL DELIVERY PIPE ASSEMBLY.](#)
- 10.** Connect the ground terminal to battery sensor.  [Ref. to REPAIR CONTENTS>NOTE > BATTERY.](#)

FUEL INJECTION (FUEL SYSTEMS)(H4DOTC) > Fuel Pressure Sensor

INSPECTION

Check that the fuel pressure sensor has no deformation, cracks or other damages.



REMOVAL



1. HIGH-PRESSURE FUEL PUMP

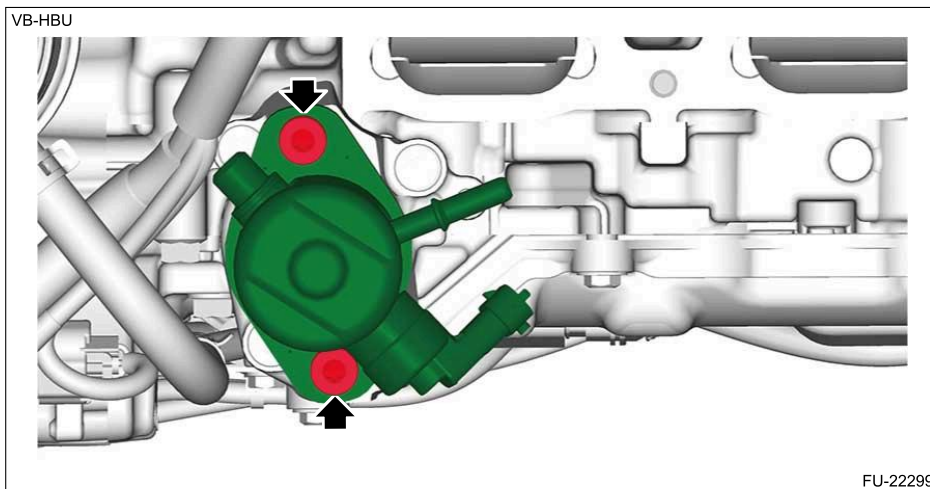
Caution:

- Be careful not to spill fuel.
- Catch the fuel from the pipes using a container or cloth.

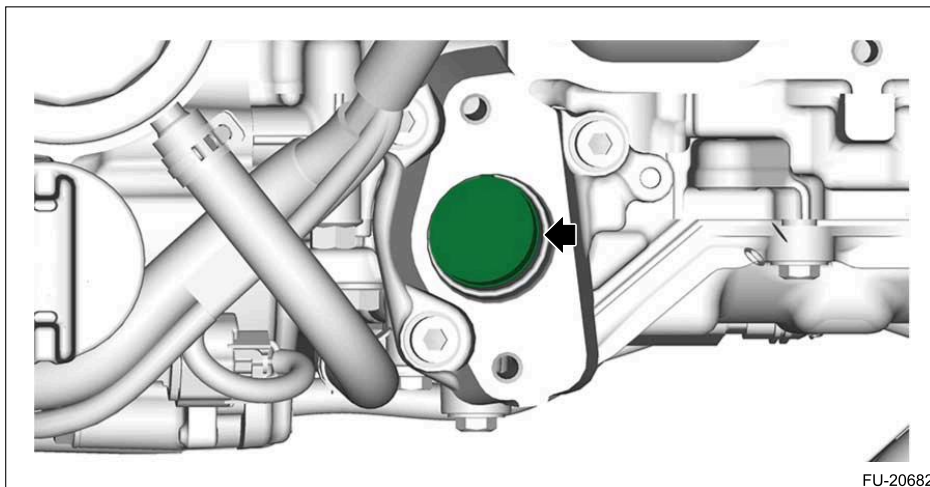
1. Disconnect the ground terminal from battery sensor.  [Ref. to REPAIR CONTENTS>NOTE > BATTERY.](#)
2. Remove the high-pressure fuel delivery pipes.  [Ref. to FUEL INJECTION \(FUEL SYSTEMS\)\(H4DOTC\)>High Pressure Fuel Delivery Pipe>REMOVAL > HIGH-PRESSURE FUEL DELIVERY PIPE.](#)
3. Using TORX PLUS® 40IP, remove the high-pressure fuel pump.

Caution:


Carefully remove it because the high-pressure fuel pump may be pressurized depending on the camshaft position.

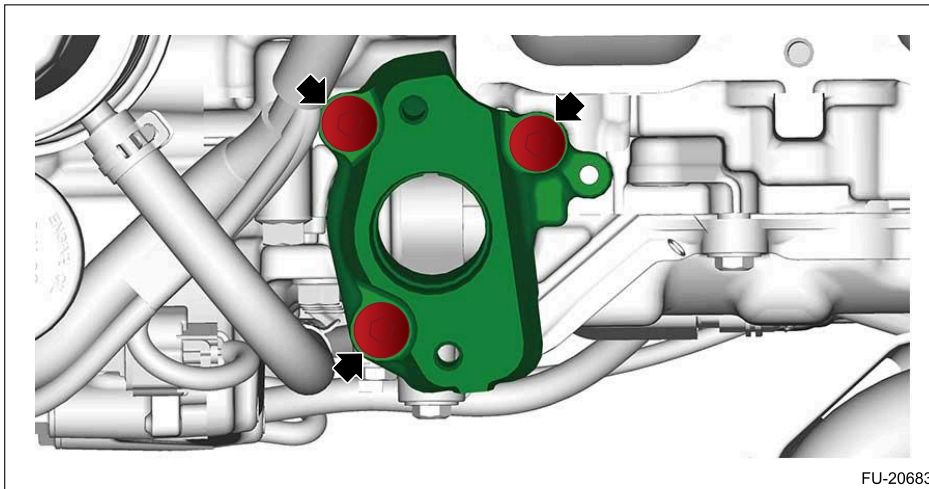


4. Remove the fuel pump lifter from the fuel pump case.



2. HIGH-PRESSURE FUEL PUMP CASE

1. Remove the high-pressure fuel pump.  [Ref. to FUEL INJECTION \(FUEL SYSTEMS\)\(H4DOTC\)>High Pressure Fuel Pump>REMOVAL > HIGH-PRESSURE FUEL PUMP.](#)
2. Remove the high-pressure fuel pump case from the cam carrier assembly LH.



3. Remove liquid gasket from the high-pressure fuel pump case and the cam carrier assembly LH.

FUEL INJECTION (FUEL SYSTEMS)(H4DOTC) > High Pressure Fuel Pump

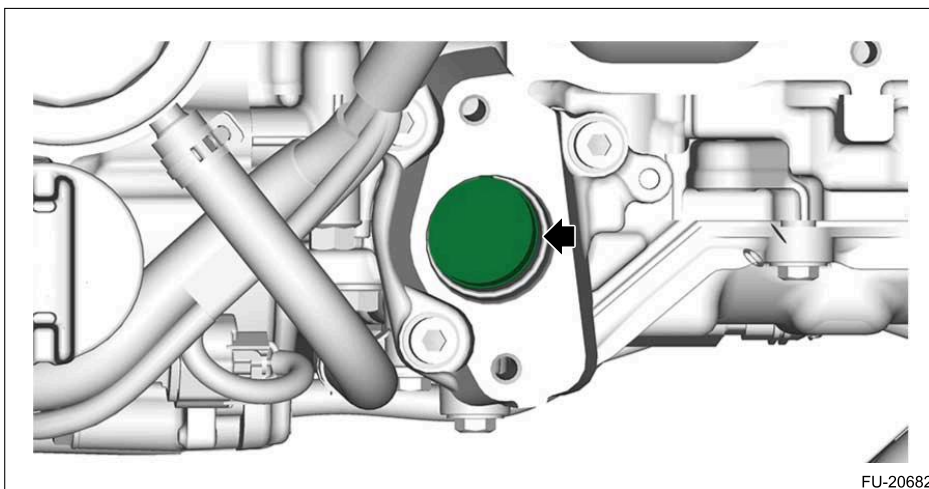
INSTALLATION

1. HIGH-PRESSURE FUEL PUMP

1. Install the high-pressure fuel pump.
 - (1) Install the fuel pump lifter to the high-pressure fuel pump case.

Note:

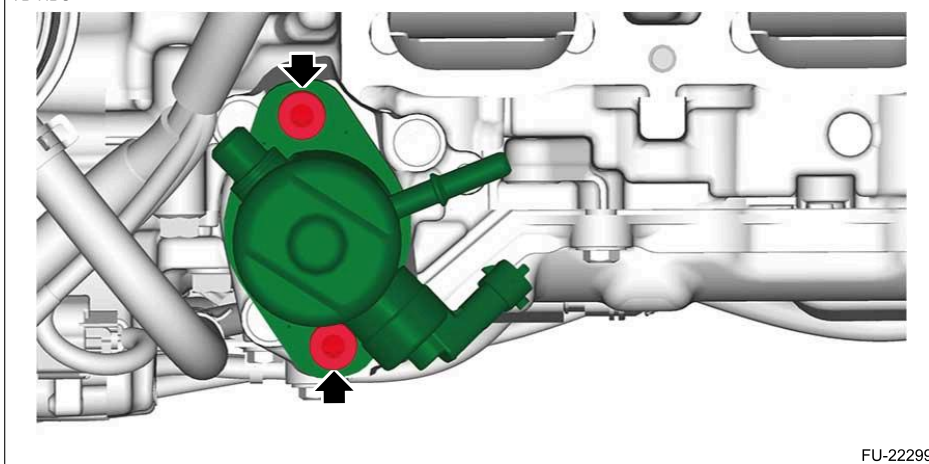
- Apply engine oil to the side of the high-pressure fuel pump case and to the bottom surface of the fuel pump lifter.
- After installing the fuel pump lifter, rotate the crankshaft in order to set the fuel pump lifter comes to the lowest position.





- (2) Set new O-rings.
- (3) Using TORX PLUS® 40IP, temporarily tighten the mounting bolts alternately to install the high-pressure fuel pump.
- (4) Tighten the bolts which hold the high-pressure fuel pump.

Tightening torque:

21 N·m (2.1 kgf-m, 15.5 ft-lb)



FU-22299

2. Install the high-pressure fuel delivery pipe.  Ref. to [FUEL INJECTION \(FUEL SYSTEMS\)\(H4DOTC\)>High Pressure Fuel Delivery Pipe>INSTALLATION > HIGH-PRESSURE FUEL DELIVERY PIPE](#).
3. Connect the ground terminal to battery sensor.  Ref. to [REPAIR CONTENTS>NOTE > BATTERY](#).

2. HIGH-PRESSURE FUEL PUMP CASE

1. Apply liquid gasket to the mating surfaces of fuel pump case, and install the high-pressure fuel pump case.

Note:

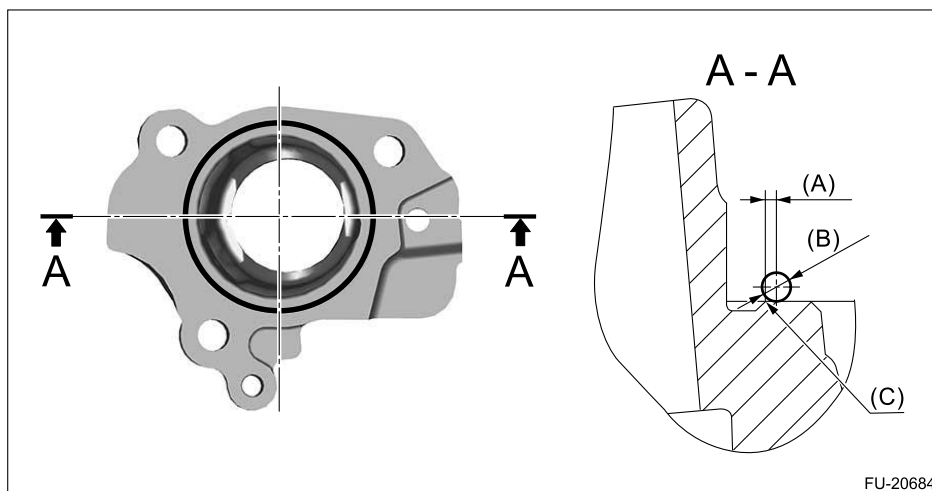
- Before applying liquid gasket, degrease the old liquid gasket seal surface of the high-pressure fuel pump case and the cam carrier assembly LH.
- Install within 5 min. after applying liquid gasket.

Preparation items:

Liquid gasket: THREE BOND 1217G (part No. K0877Y0100), THREE BOND 1217H or equivalent

Liquid gasket applying diameter:

3.5±1 mm (0.1378±0.0394 in)



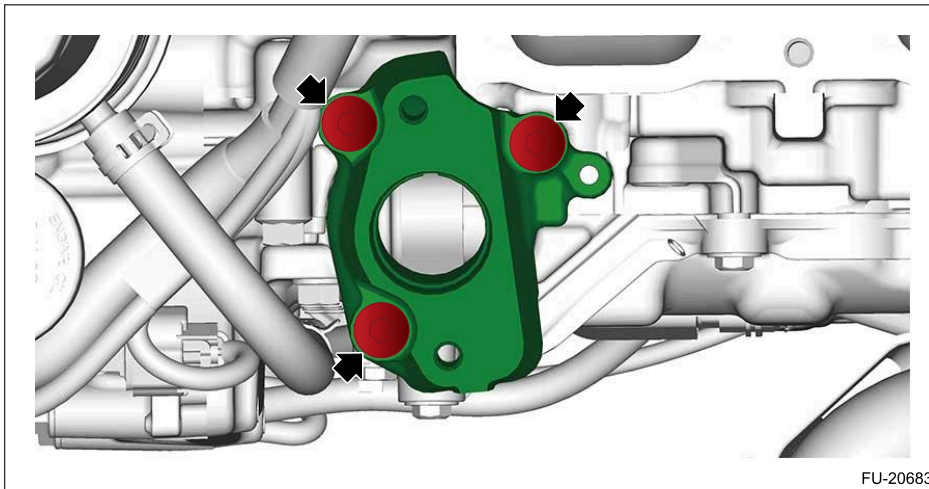
FU-20684

- (A) Within 1 mm (within 0.0394 in) (B) 3.5 mm (0.1378 in) (C) Chamfer edge

2. Install the high-pressure fuel pump case to the cam carrier assembly LH.

Tightening torque:

19 N·m (1.9 kgf-m, 14.0 ft-lb)



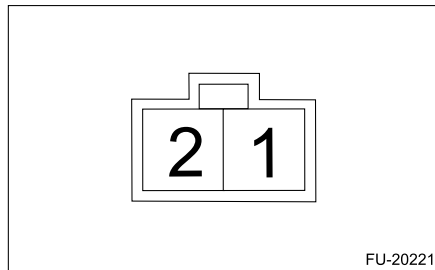
3. Install the high-pressure fuel pump.  Ref. to [FUEL INJECTION \(FUEL SYSTEMS\)\(H4DOTC\)>High Pressure Fuel Pump>INSTALLATION > HIGH-PRESSURE FUEL PUMP.](#)

FUEL INJECTION (FUEL SYSTEMS)(H4DOTC) > High Pressure Fuel Pump

INSPECTION

1. CHECK HIGH-PRESSURE FUEL PUMP

1. Check that the high-pressure fuel pump has no deformation, cracks or other damages.
2. Measure the resistance between high-pressure fuel pump terminals.



Terminal No.	Standard
1 – 2	Approx. 10 Ω (at 20°C (68°F))

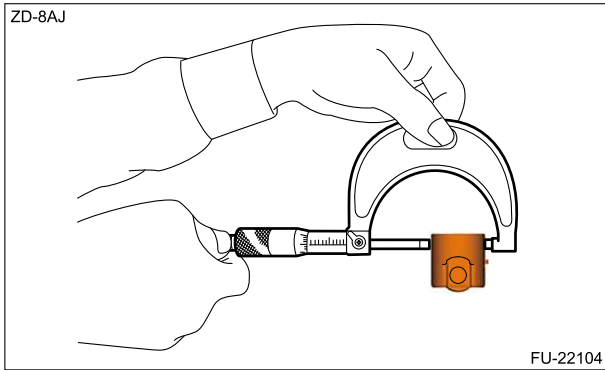
2. CHECK THE HIGH-PRESSURE FUEL PUMP CASE AND FUEL PUMP LIFTER

1. Check that the high-pressure fuel pump case and the fuel pump lifter have no deformation, cracks or other damages.
2. Check the clearance between the fuel pump lifter and high-pressure fuel pump case bore. Check the clearance between fuel pump lifter and high-pressure fuel pump case bore by measuring the outer diameter of fuel pump lifter and the inner diameter of high-pressure fuel pump case bore respectively.

(1) Measure the outer diameter of fuel pump lifter with a micrometer.

Note:

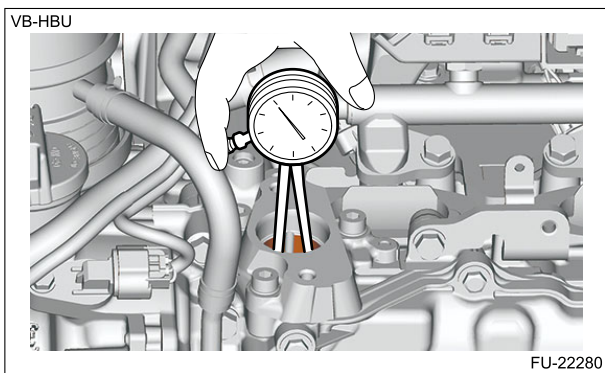
- Measurement should be performed at a temperature of 20°C (68°F).
- Measure at several points, and take notes of the value of most worn location.



(2) Using a caliper gauge, measure the inner diameter of high-pressure fuel pump case bore.

Note:

- Measurement should be performed at a temperature of 20°C (68°F).
- Measure at several points, and take notes of the value of most worn location.



(3) Calculate the clearance between the fuel pump lifter and high-pressure fuel pump case bore. If it is not within the standard, replace the fuel pump lifter and high-pressure fuel pump case as a set.

Clearance between fuel pump lifter and high-pressure fuel pump case bore:

Standard

0.039 — 0.107 mm (0.0015 — 0.0042 in)

REMOVAL

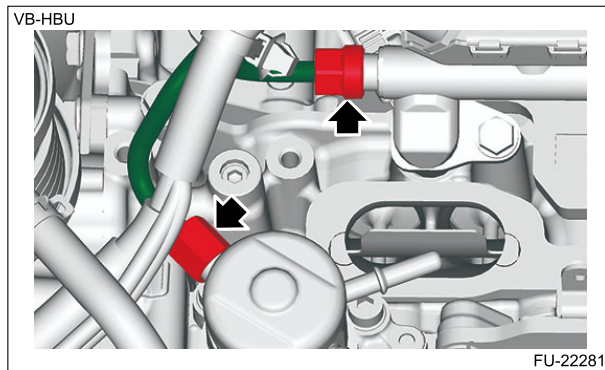


1. HIGH-PRESSURE FUEL DELIVERY PIPE

Caution:

- **Be careful not to spill fuel.**
- **Catch the fuel from the pipes using a container or cloth.**

1. Disconnect the ground terminal from battery sensor. [Ref. to REPAIR CONTENTS>NOTE > BATTERY.](#)
2. Remove the intake manifold assembly. [Ref. to FUEL INJECTION \(FUEL SYSTEMS\)\(H4DOTC\)>Intake Manifold Assembly>REMOVAL.](#)
3. Remove the fuel pump insulator, fuel pipe insulator No. 3, fuel pipe insulator No. 4 and fuel pipe insulator No. 5. [Ref. to FUEL INJECTION \(FUEL SYSTEMS\)\(H4DOTC\)>Fuel Insulator>REMOVAL.](#)
4. Remove the high-pressure fuel delivery pipes.

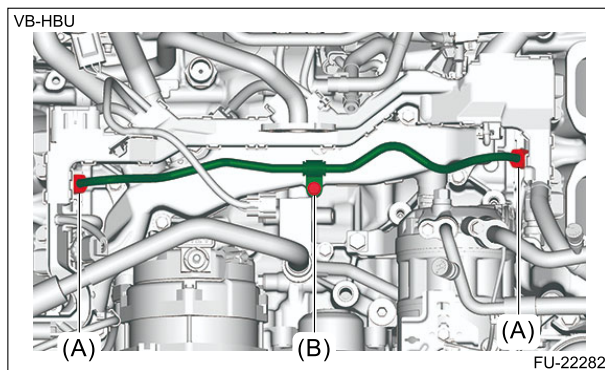


2. HIGH-PRESSURE FUEL DELIVERY PIPE ASSEMBLY

Caution:

- **Be careful not to spill fuel.**
- **Catch the fuel from the pipes using a container or cloth.**

1. Disconnect the ground terminal from battery sensor. [Ref. to REPAIR CONTENTS>NOTE > BATTERY.](#)
2. Remove the intake manifold assembly. [Ref. to FUEL INJECTION \(FUEL SYSTEMS\)\(H4DOTC\)>Intake Manifold Assembly>REMOVAL.](#)
3. Remove the fuel pipe insulator No. 1, fuel pipe insulator No. 2, fuel pipe insulator No. 3, fuel pipe insulator No. 4 and fuel pipe insulator No. 5. [Ref. to FUEL INJECTION \(FUEL SYSTEMS\)\(H4DOTC\)>Fuel Insulator>REMOVAL.](#)
4. Remove the flare nut (A) and bolt (B), and then remove the high-pressure fuel delivery pipe assembly.



INSTALLATION

1. HIGH-PRESSURE FUEL DELIVERY PIPE

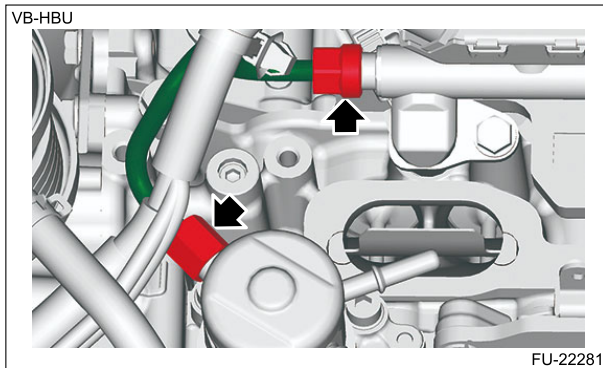
1. Temporarily tighten the flare nut of the high-pressure fuel delivery pipe by hand until it seats, and tighten the flare nuts on both ends.

Caution:

- Always use a new high-pressure fuel delivery pipe.
- Check that the seal surface of the fuel injector pipe LH and the high-pressure fuel pump have no deformation, cracks or other damages.
- Check that the seal surface of the fuel injector pipe LH and the high-pressure fuel pump have no foreign materials.

Tightening torque:

28 N·m (2.9 kgf-m, 20.7 ft-lb)



2. Install the fuel pump insulator, fuel pipe insulator No. 3, fuel pipe insulator No. 4 and fuel pipe insulator No. 5. [Ref. to FUEL INJECTION \(FUEL SYSTEMS\)\(H4DOTC\)>Fuel Insulator>INSTALLATION.](#)
3. Install the intake manifold assembly. [Ref. to FUEL INJECTION \(FUEL SYSTEMS\)\(H4DOTC\)>Intake Manifold Assembly>INSTALLATION.](#)
4. Connect the ground terminal to battery sensor. [Ref. to REPAIR CONTENTS>NOTE > BATTERY.](#)

2. HIGH-PRESSURE FUEL DELIVERY PIPE ASSEMBLY

1. Install the high-pressure fuel delivery pipe assembly.

Caution:

- Always use a new high-pressure fuel delivery pipe assembly.
- Check that the seal surface of the fuel injector pipe have no deformation, cracks or other damages.
- Check that the seal surface of the fuel injector pipe have no foreign materials.

- (1) Temporarily tighten the flare nut (A) to the fuel injector pipe by hand until it is seated, and secure the high-pressure fuel delivery pipe assembly to the water pipe assembly using bolts (B).

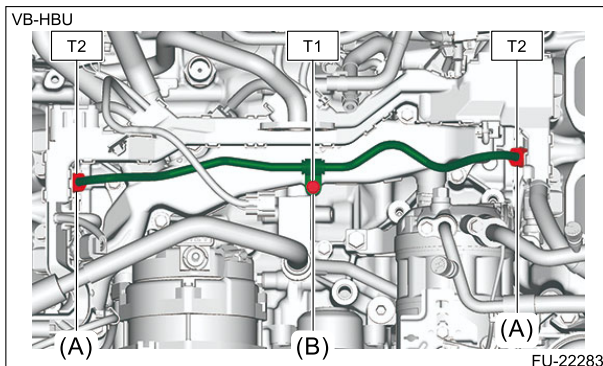
Tightening torque:




T1: 6.4 N·m (0.7 kgf-m, 4.7 ft-lb)

- (2) Tighten the flare nuts (A).

Tightening torque:

T2: 28 N·m (2.9 kgf-m, 20.7 ft-lb)



2. Install the fuel pipe insulator No. 1, fuel pipe insulator No. 2, fuel pipe insulator No. 3, fuel pipe insulator No. 4 and fuel pipe insulator No. 5.  [Ref. to FUEL INJECTION \(FUEL SYSTEMS\)\(H4DOTC\)>Fuel Insulator>INSTALLATION.](#)
3. Install the intake manifold assembly.  [Ref. to FUEL INJECTION \(FUEL SYSTEMS\)\(H4DOTC\)>Intake Manifold Assembly>INSTALLATION.](#)
4. Connect the ground terminal to battery sensor.  [Ref. to REPAIR CONTENTS>NOTE > BATTERY.](#)

FUEL INJECTION (FUEL SYSTEMS)(H4DOTC) > High Pressure Fuel Delivery Pipe

INSPECTION

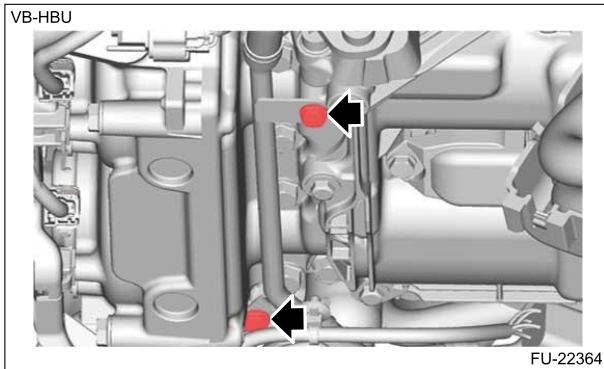
Check that the high-pressure fuel delivery pipe and the high-pressure fuel delivery pipe assembly have no deformation, cracks and other damages.

FUEL INJECTION (FUEL SYSTEMS)(H4DOTC) > Engine Wiring Harness

REMOVAL



1. Remove the battery. [Ref. to STARTING/CHARGING SYSTEMS\(H4DOTC\)>Battery>REMOVAL.](#)
2. Remove the intake manifold assembly. [Ref. to FUEL INJECTION \(FUEL SYSTEMS\)\(H4DOTC\)>Intake Manifold Assembly>REMOVAL.](#)
3. Remove the fuel insulator. [Ref. to FUEL INJECTION \(FUEL SYSTEMS\)\(H4DOTC\)>Fuel Insulator>REMOVAL.](#)
4. Remove the bolts which secure the side engine oil cooler pipe.



5. Disconnect each connector to remove the engine wiring harness. [Ref. to FUEL INJECTION \(FUEL SYSTEMS\)\(H4DOTC\)>General Description>COMPONENT > ENGINE WIRING HARNESS.](#)

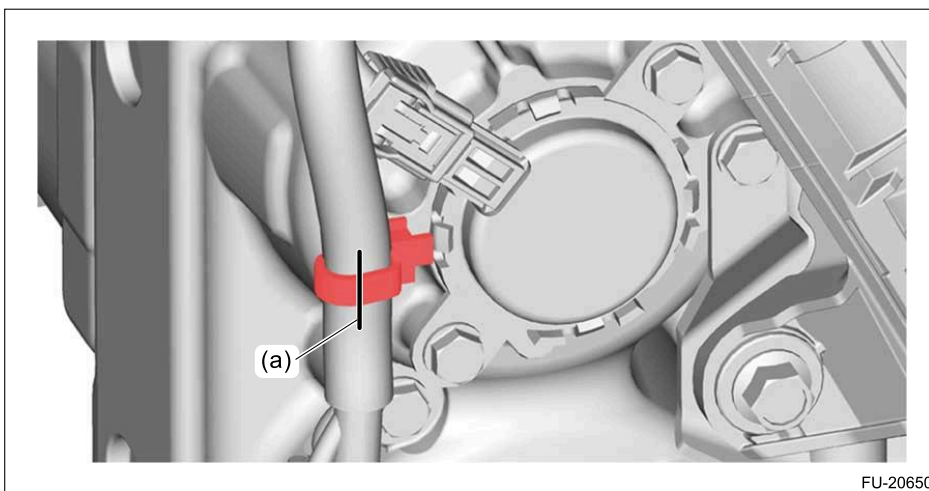
FUEL INJECTION (FUEL SYSTEMS)(H4DOTC) > Engine Wiring Harness

INSTALLATION

1. Set the engine wiring harness to the engine, and connect each connector. [Ref. to FUEL INJECTION \(FUEL SYSTEMS\)\(H4DOTC\)>General Description>COMPONENT > ENGINE WIRING HARNESS.](#)

Note:

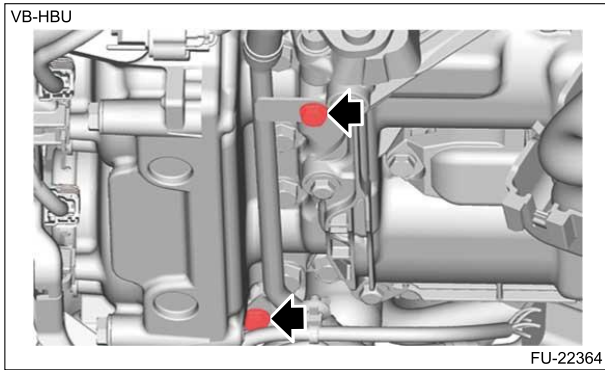
- If the clip is damaged, replace it with a new part.
- Before replacing the clip, put an alignment mark (a) on both engine wiring harness and clip to remove the clip, and then align to the alignment mark (a) to attach a new clip to the engine wiring harness.






2. Install the side engine oil cooler pipe.

Tightening torque:

6.4 N·m (0.7 kgf-m, 4.7 ft-lb)



3. Install the fuel insulator.  [Ref. to FUEL INJECTION \(FUEL SYSTEMS\)\(H4DOTC\)>Fuel Insulator>INSTALLATION.](#)
4. Install the intake manifold assembly.  [Ref. to FUEL INJECTION \(FUEL SYSTEMS\)\(H4DOTC\)>Intake Manifold Assembly>INSTALLATION.](#)
5. Install the battery.  [Ref. to STARTING/CHARGING SYSTEMS\(H4DOTC\)>Battery>INSTALLATION.](#)

FUEL INJECTION (FUEL SYSTEMS)(H4DOTC) > Engine Wiring Harness

INSPECTION

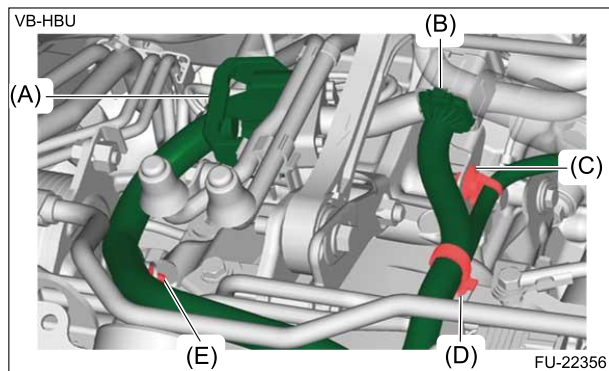
Check that the engine wiring harness does not have deformation, cracks and any other damage.

FUEL INJECTION (FUEL SYSTEMS)(H4DOTC) > Engine Coolant Temperature Sensor

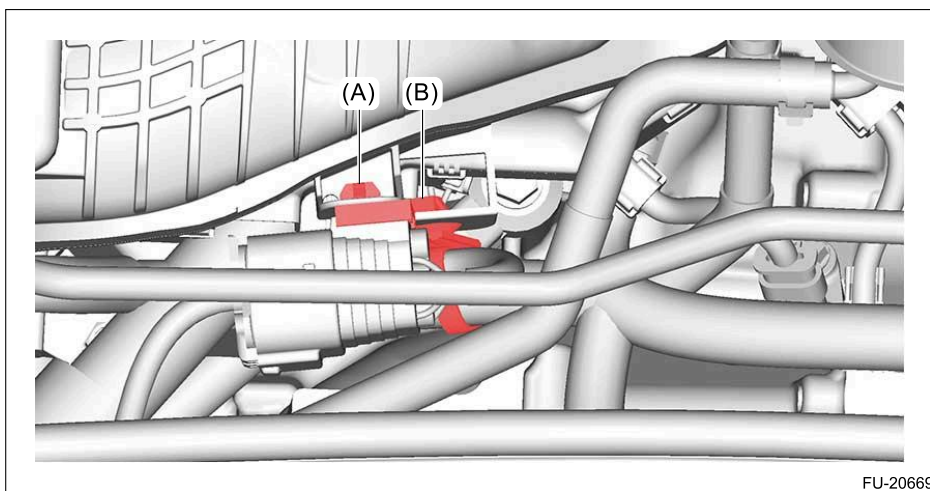
REMOVAL



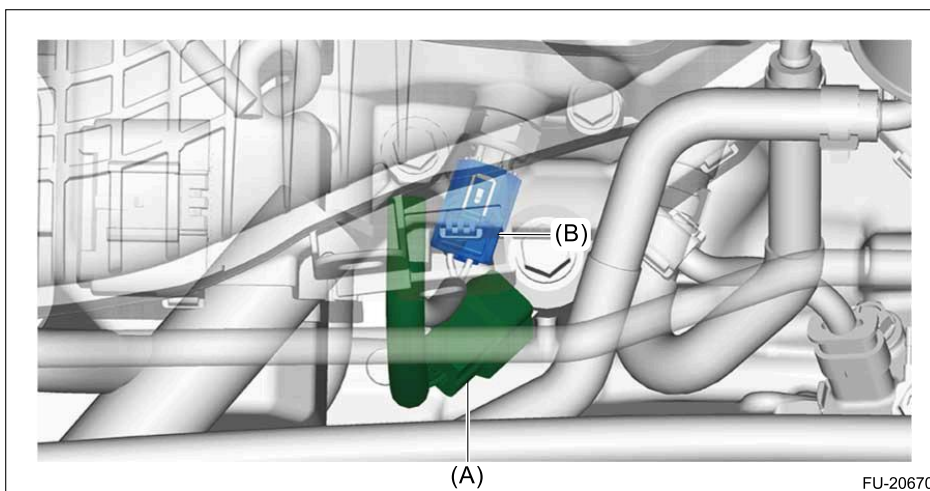
1. Disconnect the ground terminal from battery sensor. [Ref. to REPAIR CONTENTS>NOTE > BATTERY.](#)
2. Drain engine coolant. [Ref. to COOLING\(H4DOTC\)>Engine Coolant>REPLACEMENT > DRAINING OF ENGINE COOLANT.](#)
3. Remove the intercooler. [Ref. to INTAKE \(INDUCTION\)\(H4DOTC\)>Intercooler>REMOVAL.](#)
4. Disconnect the connector (A) and connector (B), and remove the clip (C), clip (D) and clip (E). (CVT model)



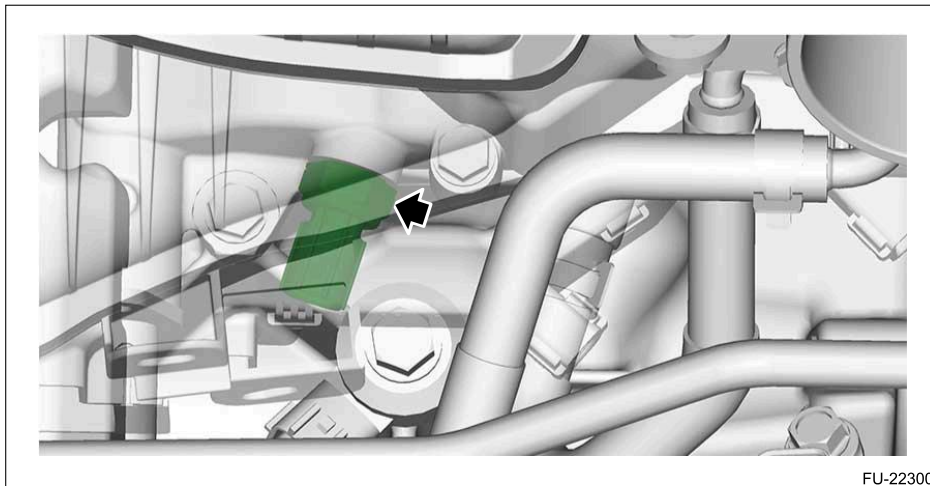
5. Remove the connector (A) and the clip (B).



6. Disconnect the connector (A) from the knock sensor, and disconnect the connector (B) from the engine coolant temperature sensor.



7. Remove the engine coolant temperature sensor.



FUEL INJECTION (FUEL SYSTEMS)(H4DOTC) > Engine Coolant Temperature Sensor

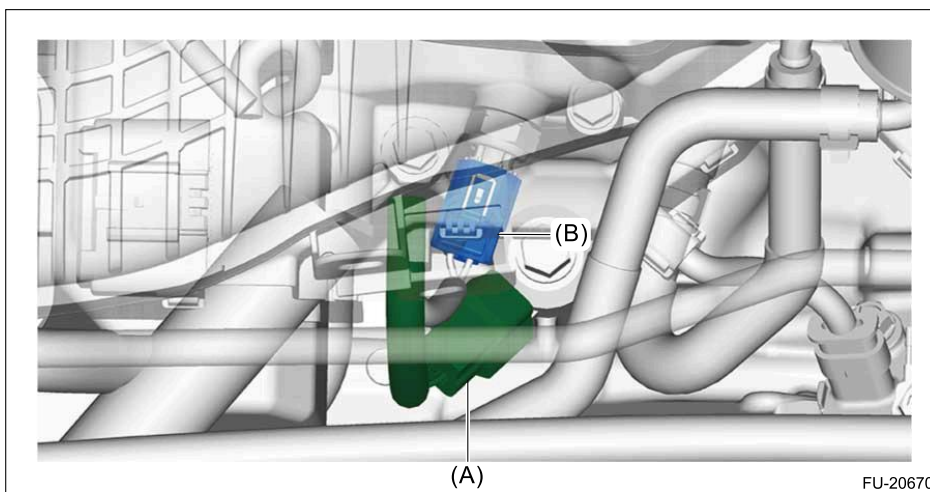
INSTALLATION

1. Place a new gasket and install the engine coolant temperature sensor.

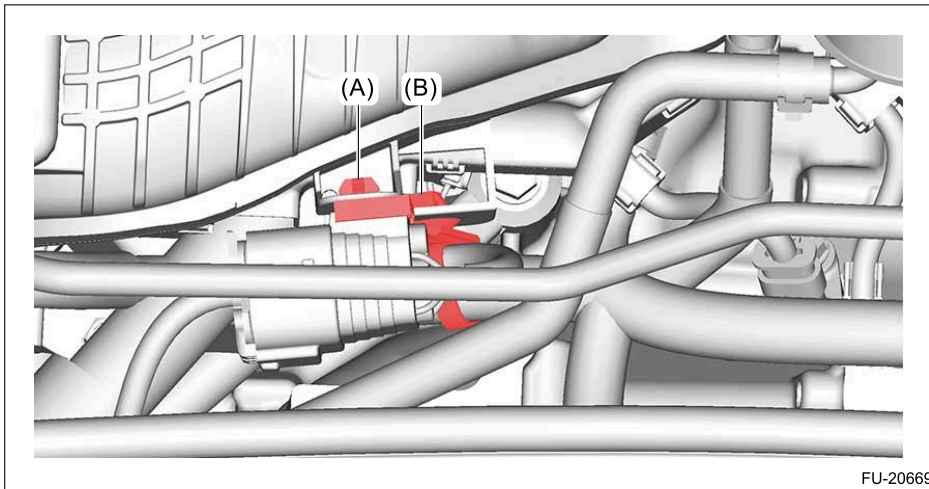
Tightening torque:

16 N·m (1.6 kgf-m, 11.8 ft-lb)

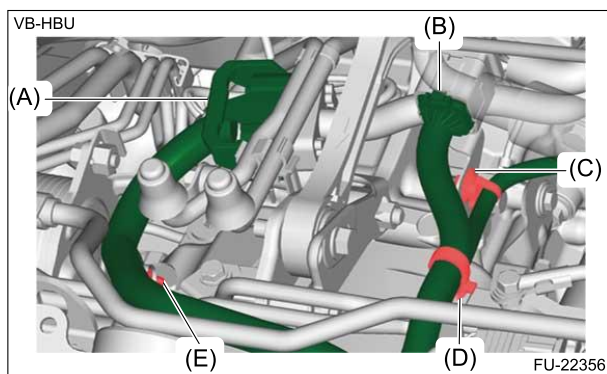
2. Connect the connector (B) to engine coolant temperature sensor and connect the connector (A) to the knock sensor.



3. Install the connector (A) and clip (B).



4. Install the clip (C), clip (D) and clip (E), and connect connector (A) and connector (B). (CVT model)



5. Install the intercooler. [🔧 Ref. to INTAKE \(INDUCTION\)\(H4DOTC\)>Intercooler>INSTALLATION.](#)
6. Connect the ground terminal to battery sensor. [🔧 Ref. to REPAIR CONTENTS>NOTE > BATTERY.](#)
7. Fill engine coolant. [🔧 Ref. to COOLING\(H4DOTC\)>Engine Coolant>REPLACEMENT > FILLING OF ENGINE COOLANT.](#)

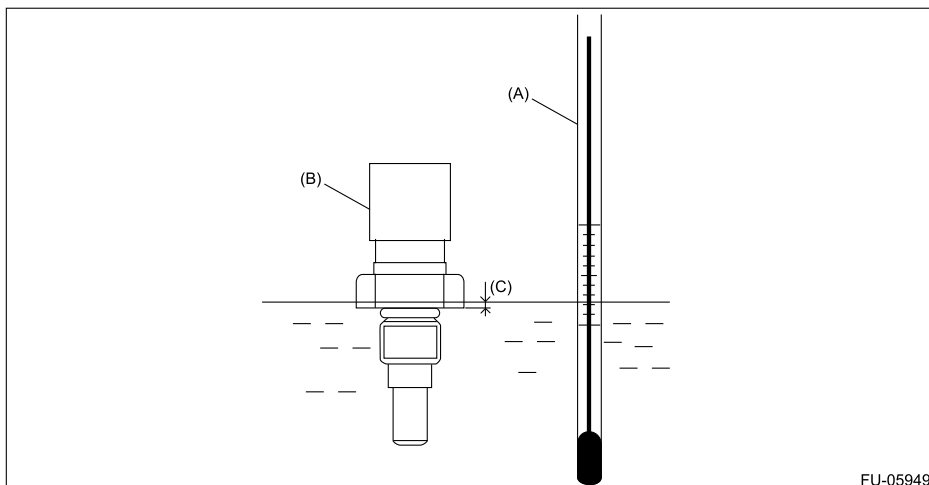
FUEL INJECTION (FUEL SYSTEMS)(H4DOTC) > Engine Coolant Temperature Sensor

INSPECTION

1. Check that the engine coolant temperature sensor has no deformation, cracks or other damages.
2. Immerse the engine coolant temperature sensor and a thermometer in water.

Caution:

Take care not to allow water to get into the engine coolant temperature sensor connector. Completely remove any water inside.



(A) Thermometer

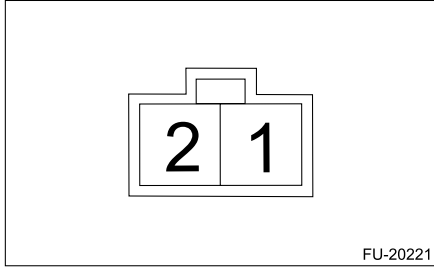
(B) Engine coolant temperature sensor

(C) Hexagonal part height: To approx. $\frac{1}{3}$

3. Raise water temperature gradually, measure the resistance between the engine coolant temperature sensor terminals when the temperature is 20°C (68°F) and 80°C (176°F).

Note:

Agitate the water for even temperature distribution.



Water temperature	Terminal No.	Standard
20°C (68°F)	1 – 2	2.25 – 2.65 kΩ
80°C (176°F)		0.305 – 0.331 kΩ


FUEL INJECTION (FUEL SYSTEMS)(H4DOTC) > Engine Oil Temperature Sensor

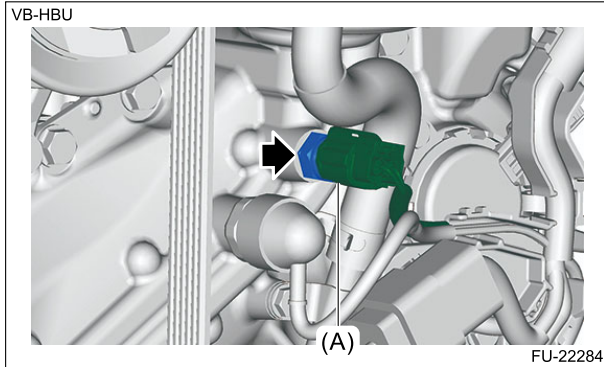
REMOVAL



Caution:


If the engine oil is spilt over exhaust pipe or the under cover, wipe it off with cloth to avoid emission of smoke or causing a fire.

1. Disconnect the ground terminal from battery sensor.  [Ref. to REPAIR CONTENTS>NOTE > BATTERY.](#)
2. Disconnect the connector (A) and remove the engine oil temperature sensor.



FUEL INJECTION (FUEL SYSTEMS)(H4DOTC) > Engine Oil Temperature Sensor

INSTALLATION

1. Place a new gasket and install the engine oil temperature sensor.
Tightening torque:
16 N·m (1.6 kgf-m, 11.8 ft-lb)
2. Connect the connector.
3. Connect the ground terminal to battery sensor.  [Ref. to REPAIR CONTENTS>NOTE > BATTERY.](#)

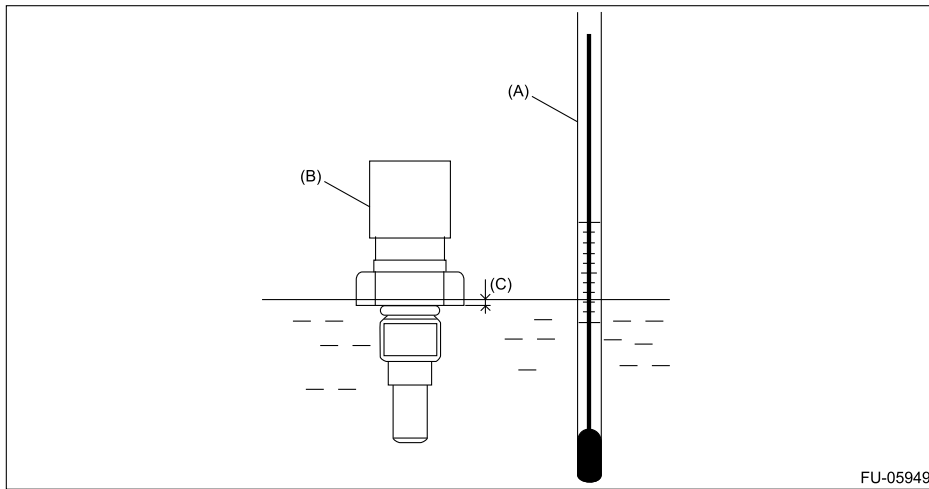
FUEL INJECTION (FUEL SYSTEMS)(H4DOTC) > Engine Oil Temperature Sensor

INSPECTION

1. Check that the engine oil temperature sensor has no deformation, cracks or other damages.
2. Immerse the engine oil temperature sensor and a thermometer in water.

Caution:

Take care not to allow water to get into the engine oil temperature sensor connector. Completely remove any water inside.



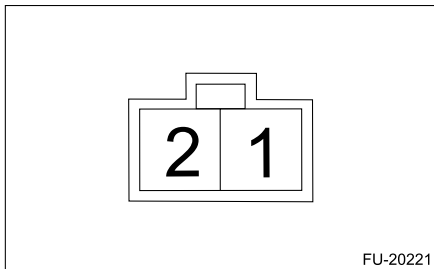
FU-05949

(A) Thermometer (B) Engine oil temperature sensor (C) Hexagonal part height: To approx. $\frac{1}{3}$

3. Raise water temperature gradually, measure the resistance between the engine oil temperature sensor terminals when the temperature is 20°C (68°F) and 80°C (176°F).

Note:

Agitate the water for even temperature distribution.





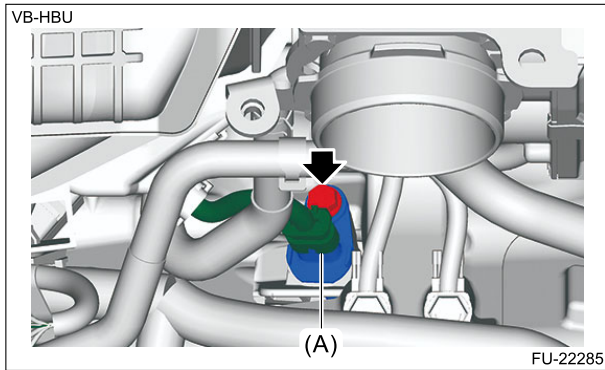
FU-20221

Water temperature	Terminal No.	Standard
20°C (68°F)	1 – 2	2.25 – 2.65 kΩ
80°C (176°F)		0.305 – 0.331 kΩ

FUEL INJECTION (FUEL SYSTEMS)(H4DOTC) > Crankshaft Position Sensor



REMOVAL

1. Disconnect the ground terminal from battery sensor.  [Ref. to REPAIR CONTENTS>NOTE > BATTERY.](#)
2. Remove the intercooler.  [Ref. to INTAKE \(INDUCTION\)\(H4DOTC\)>Intercooler>REMOVAL.](#)
3. Disconnect the connector (A) and remove the crankshaft position sensor.



FUEL INJECTION (FUEL SYSTEMS)(H4DOTC) > Crankshaft Position Sensor




INSTALLATION

1. Install the crankshaft position sensor and connect the connector.
Tightening torque:
6.4 N·m (0.7 kgf-m, 4.7 ft-lb)
2. Install the intercooler.  [Ref. to INTAKE \(INDUCTION\)\(H4DOTC\)>Intercooler>INSTALLATION.](#)
3. Connect the ground terminal to battery sensor.  [Ref. to REPAIR CONTENTS>NOTE > BATTERY.](#)

FUEL INJECTION (FUEL SYSTEMS)(H4DOTC) > Crankshaft Position Sensor

INSPECTION

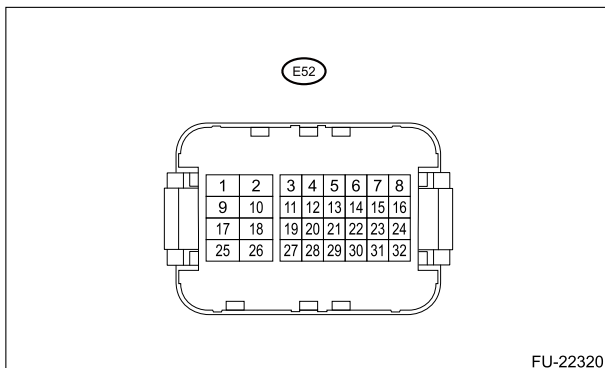
1. CRANKSHAFT POSITION SENSOR

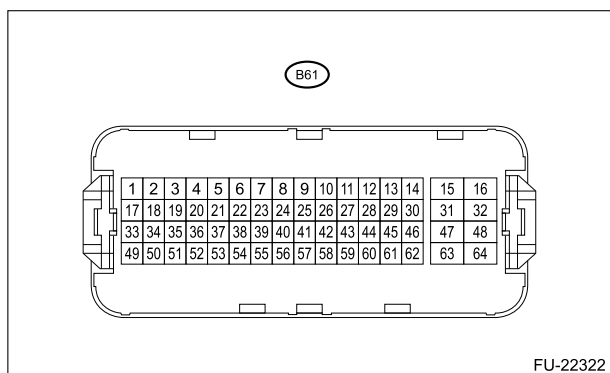
1. Disconnect the ground terminal from battery sensor.  [Ref. to REPAIR CONTENTS>NOTE > BATTERY.](#)
2. Prepare an oscilloscope.
3. Disconnect the connector from ECM.  [Ref. to FUEL INJECTION \(FUEL SYSTEMS\)\(H4DOTC\)>Engine Control Module \(ECM\)>REMOVAL.](#)
4. Attach the ST between the ECM, engine wiring harness and the bulkhead wiring harness.  [Ref. to ENGINE \(DIAGNOSTICS\) \(H4DOTC\)>General Description>PREPARATION TOOL > HOW TO USE CHECK BOARD.](#)

Special tool:

CHECK BOARD (18460AA190)

5. Connect the probe to ST.





Terminal No.	Probe
(E52) No. 4	+
(B61) No. 63	-

6. Connect the ground terminal to battery sensor. [Ref. to REPAIR CONTENTS>NOTE > BATTERY.](#)
7. Start the engine and let it idle.
8. Check the waveforms and voltage.

Note:

For waveform and voltage, refer to "Control Module (ECM) I/O Signal". [Ref. to ENGINE \(DIAGNOSTICS\) \(H4DOTC\)>Control Module I/O Signal>ELECTRICAL SPECIFICATION.](#)

9. After inspection, install the related parts in the reverse order of removal.

Note:

For installation procedures of ECM connectors, refer to Engine Control Module (ECM). [Ref. to FUEL INJECTION \(FUEL SYSTEMS\)\(H4DOTC\)>Engine Control Module \(ECM\)>INSTALLATION.](#)

2. OTHER INSPECTIONS

Check that the crankshaft position sensor has no deformation, cracks or other damages.

FUEL INJECTION (FUEL SYSTEMS)(H4DOTC) > Crankshaft Position Sensor Plate

REMOVAL

The crankshaft position sensor plate is tightened together with the drive plate or flywheel; therefore, refer to "Drive Plate" or "Flywheel" for removal procedure.

Drive plate:

 [Ref. to CONTINUOUSLY VARIABLE TRANSMISSION\(TR690\)>Drive Plate>REMOVAL.](#)

Flywheel:

 [Ref. to CLUTCH SYSTEM>Flywheel>REMOVAL.](#)

FUEL INJECTION (FUEL SYSTEMS)(H4DOTC) > Crankshaft Position Sensor Plate

INSTALLATION

The crankshaft position sensor plate is tightened together with the drive plate or flywheel; therefore, refer to "Drive Plate" or "Flywheel" for installation procedure.

Drive plate:

 [Ref. to CONTINUOUSLY VARIABLE TRANSMISSION\(TR690\)>Drive Plate>INSTALLATION.](#)

Flywheel:

 [Ref. to CLUTCH SYSTEM>Flywheel>INSTALLATION.](#)

FUEL INJECTION (FUEL SYSTEMS)(H4DOTC) > Crankshaft Position Sensor Plate

INSPECTION

Check that the crankshaft position sensor plate has no deformation, cracks or other damages.

REMOVAL





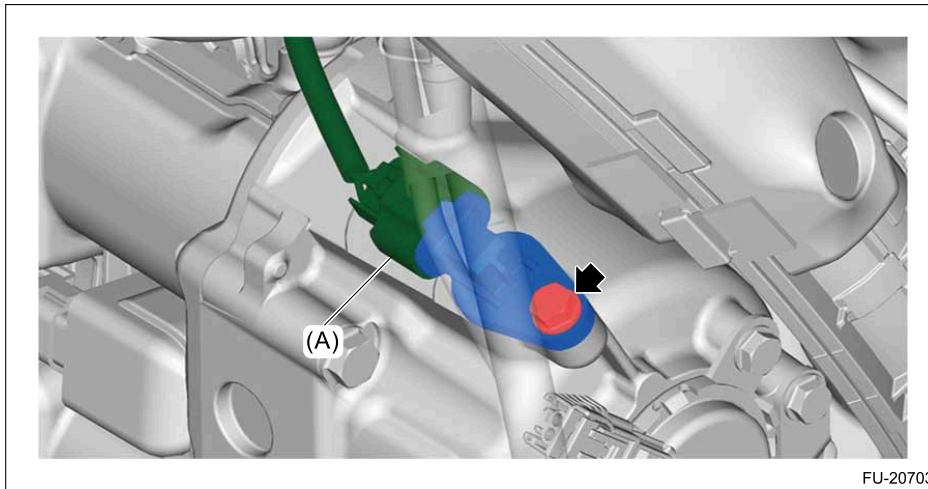
Caution:

If the engine oil is spilt over exhaust pipe or the under cover, wipe it off with cloth to avoid emission of smoke or causing a fire.


1. INTAKE

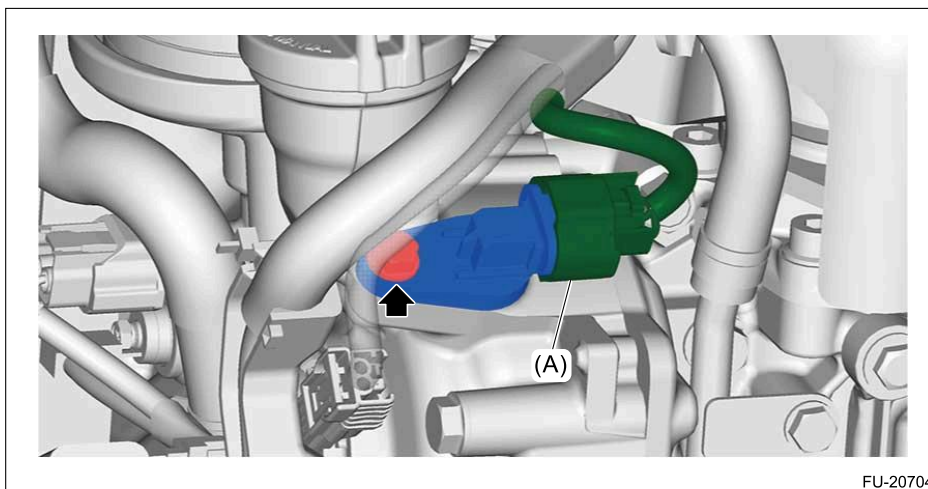
• RH SIDE

1. Disconnect the ground terminal from battery sensor.  [Ref. to REPAIR CONTENTS>NOTE > BATTERY.](#)
2. Remove the air intake duct.  [Ref. to INTAKE \(INDUCTION\)\(H4DOTC\)>Air Intake Duct>REMOVAL.](#)
3. Disconnect the connector (A) and remove the camshaft position sensor.




• LH SIDE

1. Disconnect the ground terminal from battery sensor.  [Ref. to REPAIR CONTENTS>NOTE > BATTERY.](#)
2. Disconnect the connector (A) and remove the camshaft position sensor.

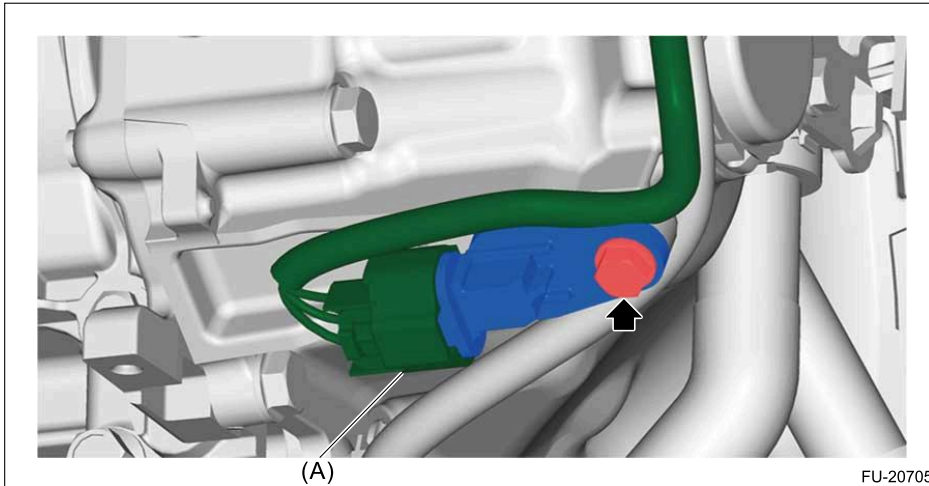


2. EXHAUST

• RH SIDE

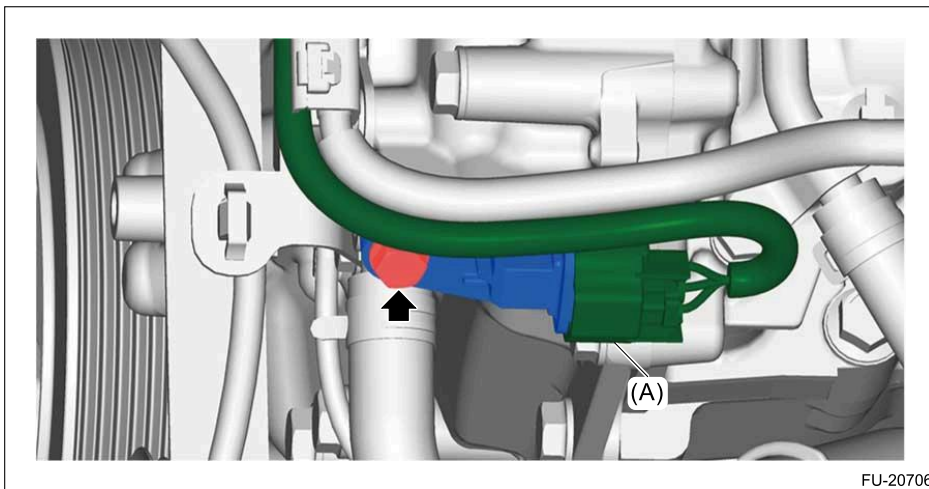
1. Disconnect the ground terminal from battery sensor.  [Ref. to REPAIR CONTENTS>NOTE > BATTERY.](#)
2. Lift up the vehicle.
3. Remove the under cover front.  [Ref. to EXTERIOR/INTERIOR TRIM>Front Under Cover>REMOVAL.](#)

4. Disconnect the connector (A) and remove the camshaft position sensor.



• LH SIDE

1. Disconnect the ground terminal from battery sensor. [🔧 Ref. to REPAIR CONTENTS>NOTE > BATTERY.](#)
2. Lift up the vehicle.
3. Remove the under cover front. [🔧 Ref. to EXTERIOR/INTERIOR TRIM>Front Under Cover>REMOVAL.](#)
4. Disconnect the connector (A) and remove the camshaft position sensor.



FUEL INJECTION (FUEL SYSTEMS)(H4DOTC) > Camshaft Position Sensor

INSTALLATION

1. INTAKE

• RH SIDE

1. Install the camshaft position sensor with new O-ring.

Note:

Apply engine oil to O-ring.

Tightening torque:

6.4 N·m (0.7 kgf-m, 4.7 ft-lb)

2. Connect the connector.
3. Install the air intake duct. [🔧 Ref. to INTAKE \(INDUCTION\)\(H4DOTC\)>Air Intake Duct>INSTALLATION.](#)
4. Connect the ground terminal to battery sensor. [🔧 Ref. to REPAIR CONTENTS>NOTE > BATTERY.](#)

• LH SIDE

1. Install the camshaft position sensor with new O-ring.

Note:

Apply engine oil to O-ring.

Tightening torque:

6.4 N·m (0.7 kgf-m, 4.7 ft-lb)

2. Connect the connector.
3. Connect the ground terminal to battery sensor. [🔧 Ref. to REPAIR CONTENTS>NOTE > BATTERY.](#)

2. EXHAUST

• RH SIDE

1. Install the camshaft position sensor with new O-ring.

Note:

Apply engine oil to O-ring.

Tightening torque:

6.4 N·m (0.7 kgf-m, 4.7 ft-lb)

2. Connect the connector.
3. Install the under cover front. [🔧 Ref. to EXTERIOR/INTERIOR TRIM>Front Under Cover>INSTALLATION.](#)
4. Lower the vehicle.
5. Connect the ground terminal to battery sensor. [🔧 Ref. to REPAIR CONTENTS>NOTE > BATTERY.](#)

• LH SIDE

1. Install the camshaft position sensor with new O-ring.

Note:

Apply engine oil to O-ring.

Tightening torque:

6.4 N·m (0.7 kgf-m, 4.7 ft-lb)

2. Connect the connector.
3. Install the under cover front. [🔧 Ref. to EXTERIOR/INTERIOR TRIM>Front Under Cover>INSTALLATION.](#)
4. Lower the vehicle.
5. Connect the ground terminal to battery sensor. [🔧 Ref. to REPAIR CONTENTS>NOTE > BATTERY.](#)

FUEL INJECTION (FUEL SYSTEMS)(H4DOTC) > Camshaft Position Sensor

INSPECTION

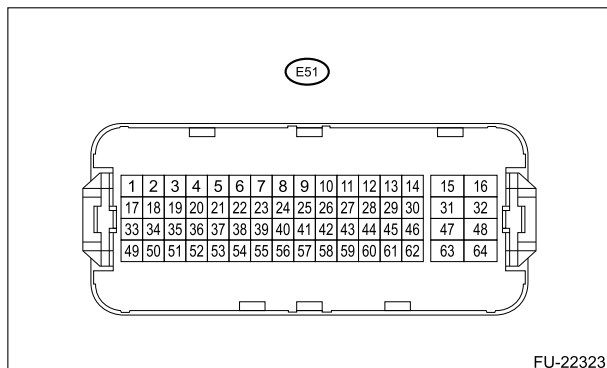
1. CAMSHAFT POSITION SENSOR

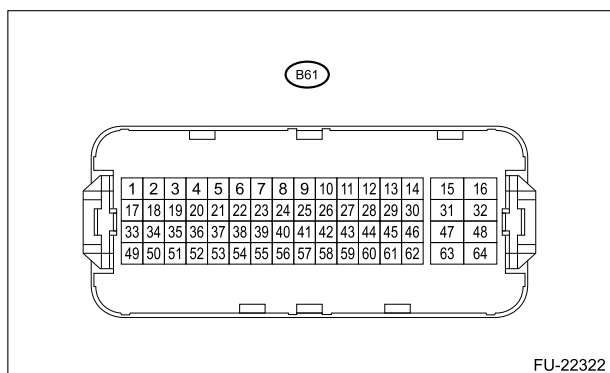
1. Disconnect the ground terminal from battery sensor. [🔧 Ref. to REPAIR CONTENTS>NOTE > BATTERY.](#)
2. Prepare an oscilloscope.
3. Disconnect the connector from ECM. [🔧 Ref. to FUEL INJECTION \(FUEL SYSTEMS\)\(H4DOTC\)>Engine Control Module \(ECM\)>REMOVAL.](#)
4. Attach the ST between the ECM, engine harness and the bulkhead wiring harness. [🔧 Ref. to ENGINE \(DIAGNOSTICS\)\(H4DOTC\)>General Description>PREPARATION TOOL > HOW TO USE CHECK BOARD.](#)

Special tool:

CHECK BOARD (18460AA190)

5. Connect the probe to ST.





Camshaft position sensor		Terminal No.	Probe
Intake	RH	(E51) No. 56	+
	LH	(E51) No. 57	+
Exhaust	RH	(E51) No. 24	+
	LH	(E51) No. 40	+
RH and LH		(B61) No. 63	-

6. Connect the ground terminal to battery sensor. [Ref. to REPAIR CONTENTS>NOTE > BATTERY.](#)
7. Start the engine and let it idle.
8. Check the waveforms and voltage.

Note:

For waveform and voltage, refer to "Control Module (ECM) I/O Signal". [Ref. to ENGINE \(DIAGNOSTICS\) \(H4DOTC\)>Control Module I/O Signal>ELECTRICAL SPECIFICATION.](#)

9. After inspection, install the related parts in the reverse order of removal.

Note:

For installation procedures of ECM connectors, refer to Engine Control Module (ECM). [Ref. to FUEL INJECTION \(FUEL SYSTEMS\)\(H4DOTC\)>Engine Control Module \(ECM\)>INSTALLATION.](#)

2. OTHER INSPECTIONS

Check that the camshaft position sensor has no deformation, cracks or other damages.

REMOVAL



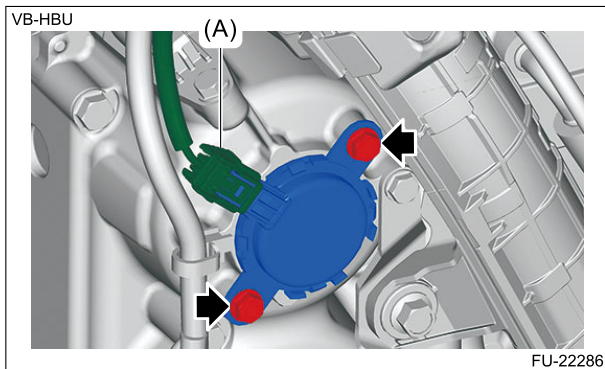
Caution:

If the engine oil is spilt over exhaust pipe or the under cover, wipe it off with cloth to avoid emission of smoke or causing a fire.

1. INTAKE

• RH SIDE

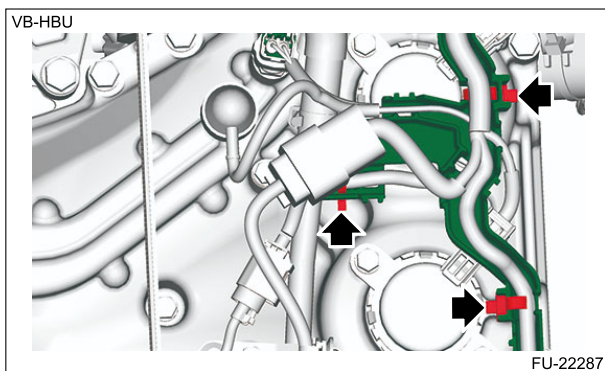
1. Disconnect the ground terminal from battery sensor. [Ref. to REPAIR CONTENTS>NOTE > BATTERY.](#)
2. Remove the air intake duct. [Ref. to INTAKE \(INDUCTION\)\(H4DOTC\)>Air Intake Duct>REMOVAL.](#)
3. Disconnect the connector (A) and remove the oil control solenoid.



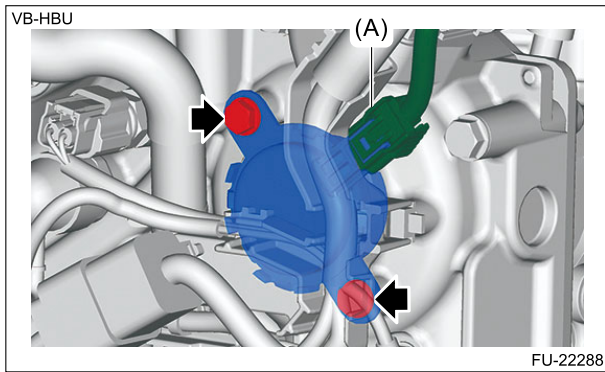
4. Remove the O-ring and back-up ring from the oil control solenoid.

• LH SIDE

1. Disconnect the ground terminal from battery sensor. [Ref. to REPAIR CONTENTS>NOTE > BATTERY.](#)
2. Remove the reservoir tank. [Ref. to COOLING\(H4DOTC\)>Reservoir Tank>REMOVAL.](#)
3. Remove the clip securing the engine wiring harness.



4. Disconnect the connector (A) and remove the oil control solenoid.

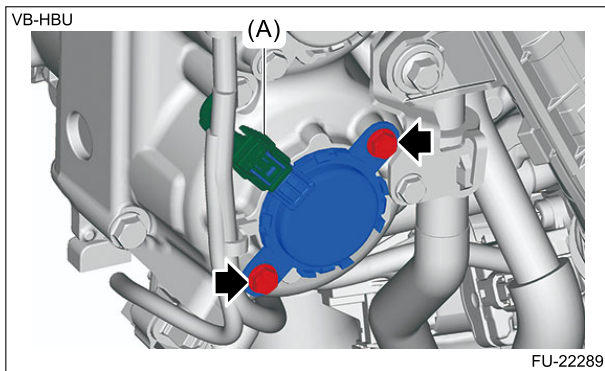


5. Remove the O-ring and back-up ring from the oil control solenoid.

2. EXHAUST

• RH SIDE

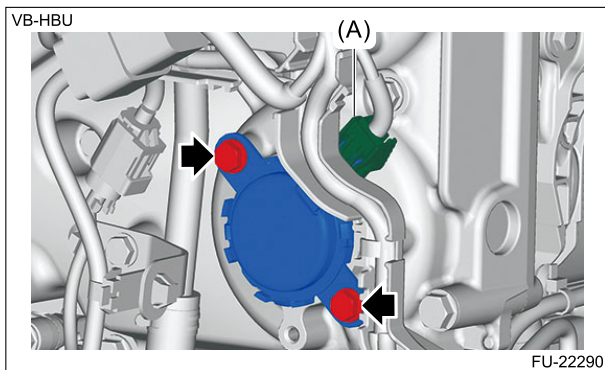
1. Disconnect the ground terminal from battery sensor. [Ref. to REPAIR CONTENTS>NOTE > BATTERY.](#)
2. Remove the air intake duct. [Ref. to INTAKE \(INDUCTION\)\(H4DOTC\)>Air Intake Duct>REMOVAL.](#)
3. Disconnect the connector (A) and remove the oil control solenoid.



4. Remove the O-ring and back-up ring from the oil control solenoid.

• LH SIDE

1. Disconnect the ground terminal from battery sensor. [Ref. to REPAIR CONTENTS>NOTE > BATTERY.](#)
2. Remove the reservoir tank. [Ref. to COOLING\(H4DOTC\)>Reservoir Tank>REMOVAL.](#)
3. Disconnect the connector (A) and remove the oil control solenoid.



4. Remove the O-ring and back-up ring from the oil control solenoid.

FUEL INJECTION (FUEL SYSTEMS)(H4DOTC) > Oil Control Solenoid

INSTALLATION

1. INTAKE

• RH SIDE

1. Install the backup ring to the oil control solenoid.
2. Using a new O-ring, install the oil control solenoid.

Note:

Apply engine oil to O-ring.

Tightening torque:

6.4 N·m (0.7 kgf-m, 4.7 ft-lb)

3. Connect the connector.
4. Install the air intake duct. [🔗 Ref. to INTAKE \(INDUCTION\)\(H4DOTC\)>Air Intake Duct>INSTALLATION.](#)
5. Connect the ground terminal to battery sensor. [🔗 Ref. to REPAIR CONTENTS>NOTE > BATTERY.](#)

• **LH SIDE**

1. Install the backup ring to the oil control solenoid.
2. Using a new O-ring, install the oil control solenoid.

Note:

Apply engine oil to O-ring.

Tightening torque:

6.4 N·m (0.7 kgf-m, 4.7 ft-lb)

3. Connect the connector.
4. Hold the engine wiring harness with the clip.
5. Install the reservoir tank. [🔗 Ref. to COOLING\(H4DOTC\)>Reservoir Tank>INSTALLATION.](#)
6. Connect the ground terminal to battery sensor. [🔗 Ref. to REPAIR CONTENTS>NOTE > BATTERY.](#)

2. EXHAUST SIDE

• **RH SIDE**

1. Install the backup ring to the oil control solenoid.
2. Using a new O-ring, install the oil control solenoid.

Note:

Apply engine oil to O-ring.

Tightening torque:

6.4 N·m (0.7 kgf-m, 4.7 ft-lb)

3. Connect the connector.
4. Install the air intake duct. [🔗 Ref. to INTAKE \(INDUCTION\)\(H4DOTC\)>Air Intake Duct>INSTALLATION.](#)
5. Connect the ground terminal to battery sensor. [🔗 Ref. to REPAIR CONTENTS>NOTE > BATTERY.](#)

• **LH SIDE**

1. Install the backup ring to the oil control solenoid.
2. Using a new O-ring, install the oil control solenoid.

Note:

Apply engine oil to O-ring.

Tightening torque:

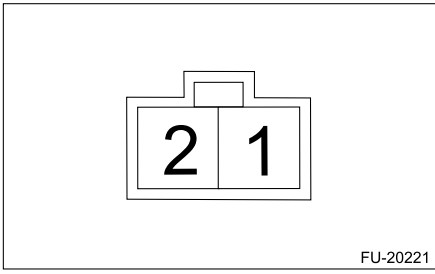
6.4 N·m (0.7 kgf-m, 4.7 ft-lb)

3. Connect the connector.
4. Install the reservoir tank. [🔗 Ref. to COOLING\(H4DOTC\)>Reservoir Tank>INSTALLATION.](#)
5. Connect the ground terminal to battery sensor. [🔗 Ref. to REPAIR CONTENTS>NOTE > BATTERY.](#)

FUEL INJECTION (FUEL SYSTEMS)(H4DOTC) > Oil Control Solenoid

INSPECTION

1. Check that the oil control solenoid has no deformation, cracks or other damages.
2. Measure the resistance between the oil control solenoid terminals.



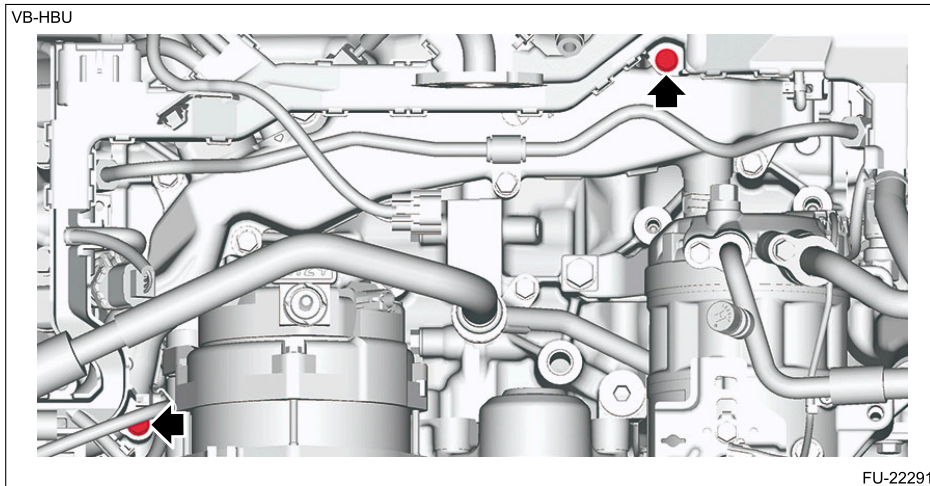
Terminal No.	Standard
1 – 2	6.85 – 7.65 Ω (at 20°C (68°F))

REMOVAL

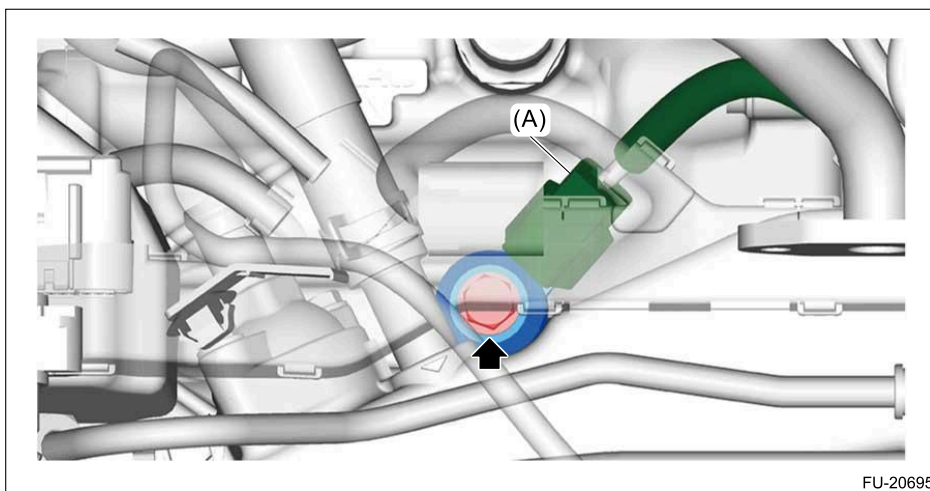


1. RH SIDE

1. Disconnect the ground terminal from battery sensor. [Ref. to REPAIR CONTENTS>NOTE > BATTERY.](#)
2. Remove the intake manifold assembly. [Ref. to FUEL INJECTION \(FUEL SYSTEMS\)\(H4DOTC\)>Intake Manifold Assembly>REMOVAL.](#)
3. Remove the fuel pipe insulator No. 3. [Ref. to FUEL INJECTION \(FUEL SYSTEMS\)\(H4DOTC\)>Fuel Insulator>REMOVAL.](#)
4. Remove the bolts securing the engine wiring harness.

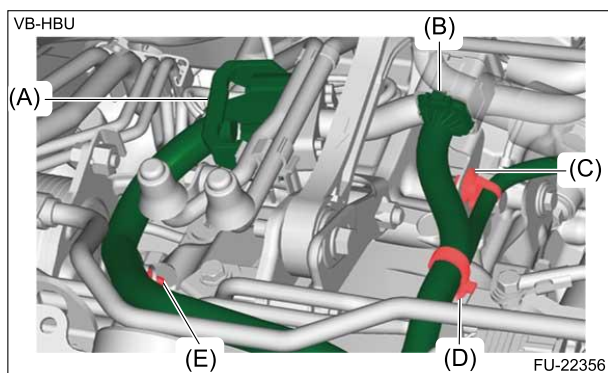


5. Disconnect the connector (A) and remove the knock sensor.

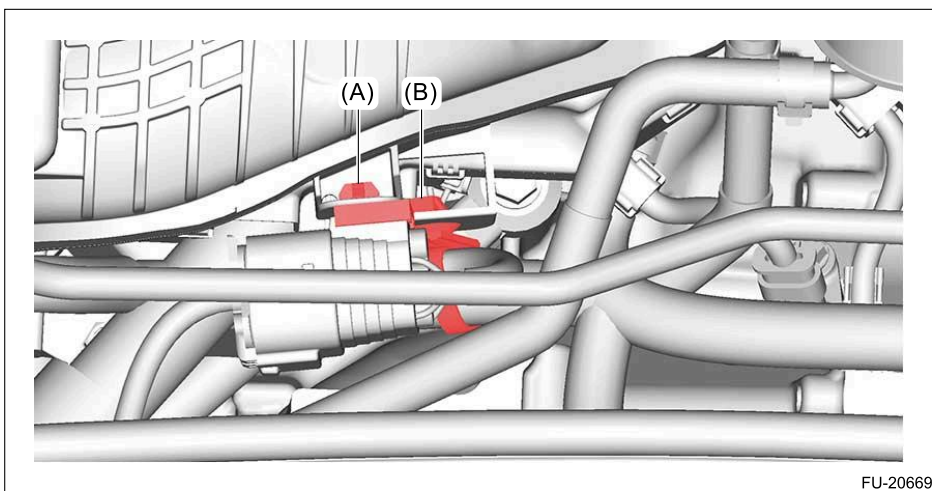


2. LH SIDE

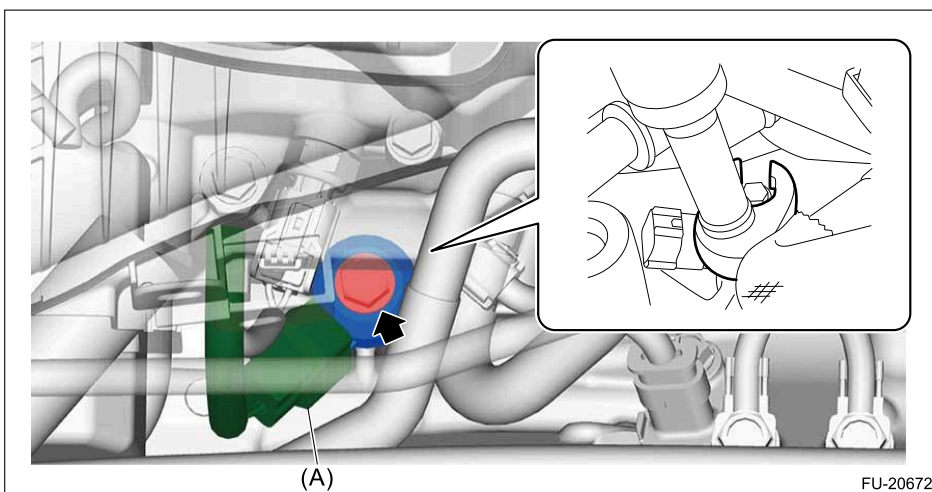
1. Disconnect the ground terminal from battery sensor. [Ref. to REPAIR CONTENTS>NOTE > BATTERY.](#)
2. Remove the intercooler. [Ref. to INTAKE \(INDUCTION\)\(H4DOTC\)>Intercooler>REMOVAL.](#)
3. Disconnect the connector (A) and connector (B), and remove the clip (C), clip (D) and clip (E). (CVT model)



4. Remove the connector (A) and the clip (B).



5. Disconnect the connector (A) and remove the knock sensor using a claw-foot wrench.



FUEL INJECTION (FUEL SYSTEMS)(H4DOTC) > Knock Sensor

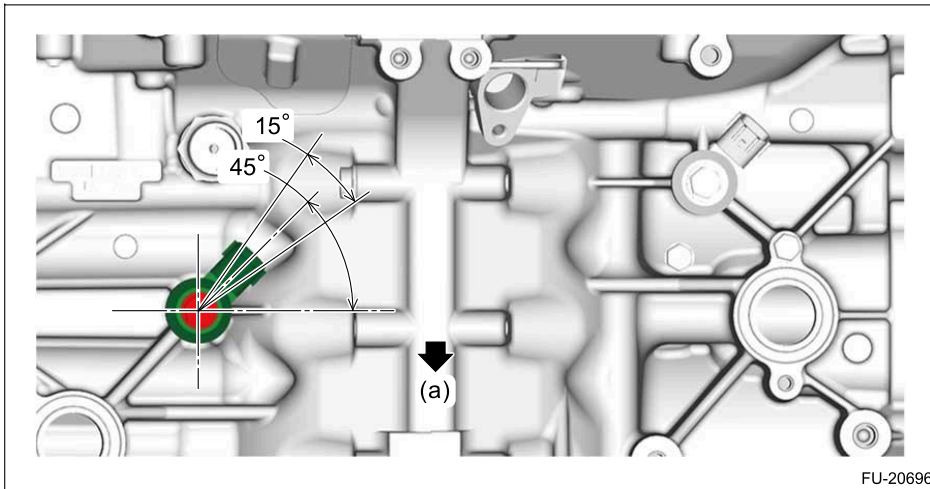
INSTALLATION

1. RH SIDE

1. Install the knock sensor and connect the connector (A).

Note:

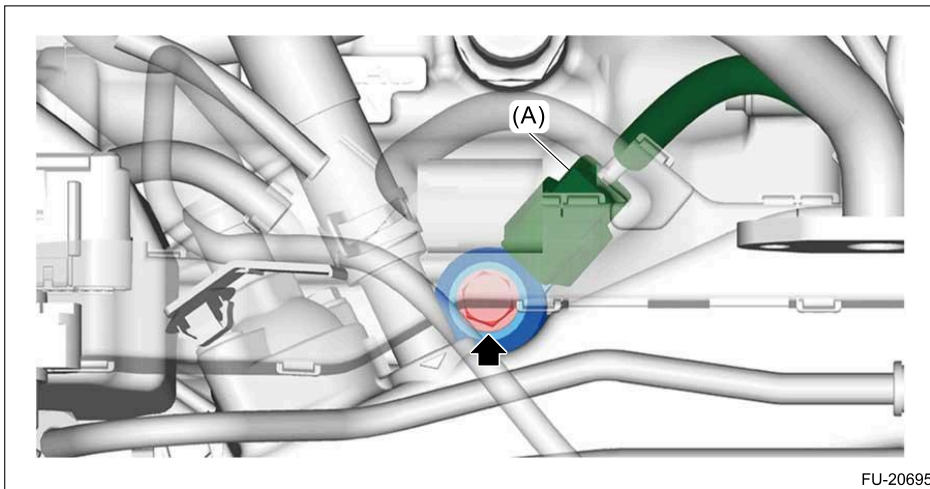
- Knock sensor must be positioned so that the connector center comes within the range shown in the figure.
- Make sure that the knock sensor and its connector do not touch the adjacent parts.



(a) Front of engine

Tightening torque:

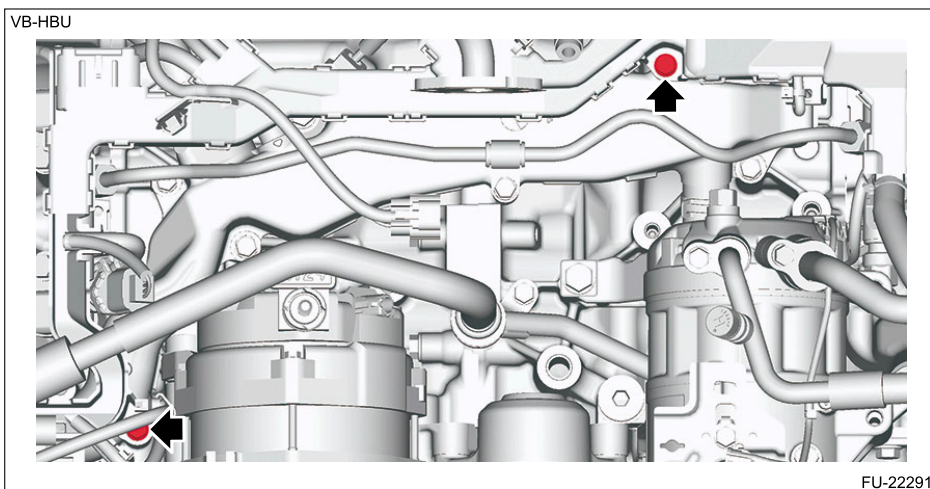
24 N·m (2.4 kgf-m, 17.7 ft-lb)



2. Secure the engine wiring harness with the bolts.

Tightening torque:

6.4 N·m (0.7 kgf-m, 4.7 ft-lb)



3. Install the fuel pipe insulator No. 3.  [Ref. to FUEL INJECTION \(FUEL SYSTEMS\)\(H4DOTC\)>Fuel Insulator>INSTALLATION.](#)

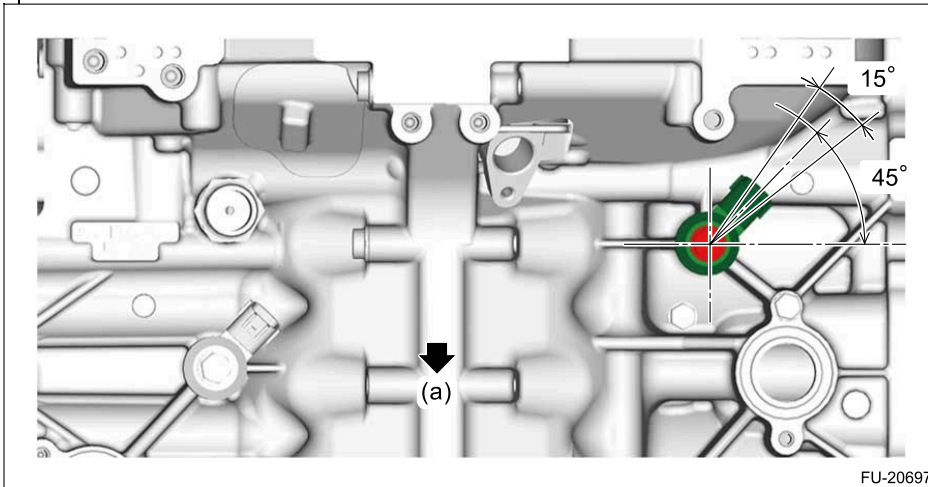
4. Install the intake manifold assembly.  [Ref. to FUEL INJECTION \(FUEL SYSTEMS\)\(H4DOTC\)>Intake Manifold Assembly>INSTALLATION.](#)
5. Connect the ground terminal to battery sensor.  [Ref. to REPAIR CONTENTS>NOTE > BATTERY.](#)

2. LH SIDE

1. Using a claw-foot wrench, install the knock sensor and connect the connector (A).

Note:

- Knock sensor must be positioned so that the connector center comes within the range shown in the figure.
- Make sure that the knock sensor and its connector do not touch the adjacent parts.



(a) Front of engine

FU-20697

Tightening torque:

Calculation formula

$$T = 24 \text{ N}\cdot\text{m} (2.4 \text{ kgf}\cdot\text{m}, 17.7 \text{ ft}\cdot\text{lb}) \times L1 / (L1 + L2)$$

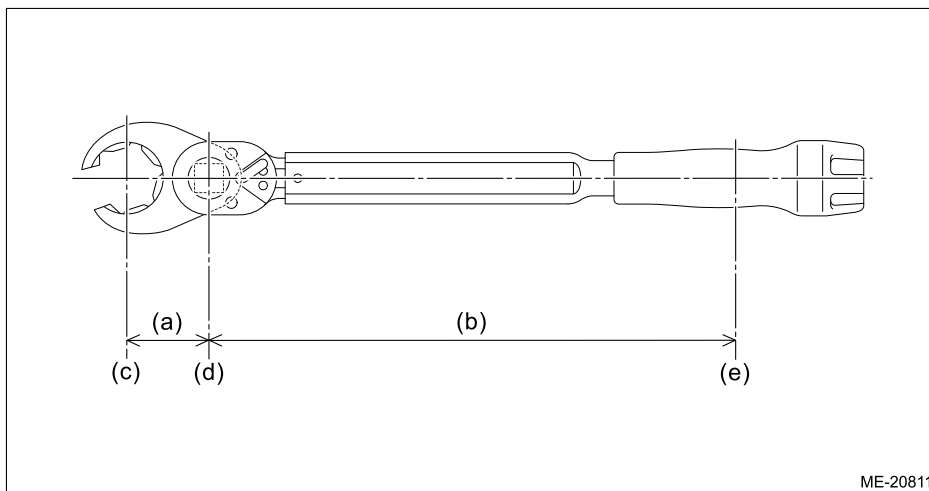
T: Reading of the torque wrench

L1: Effective length of the torque wrench

L2: Effective length of the crowfoot wrench

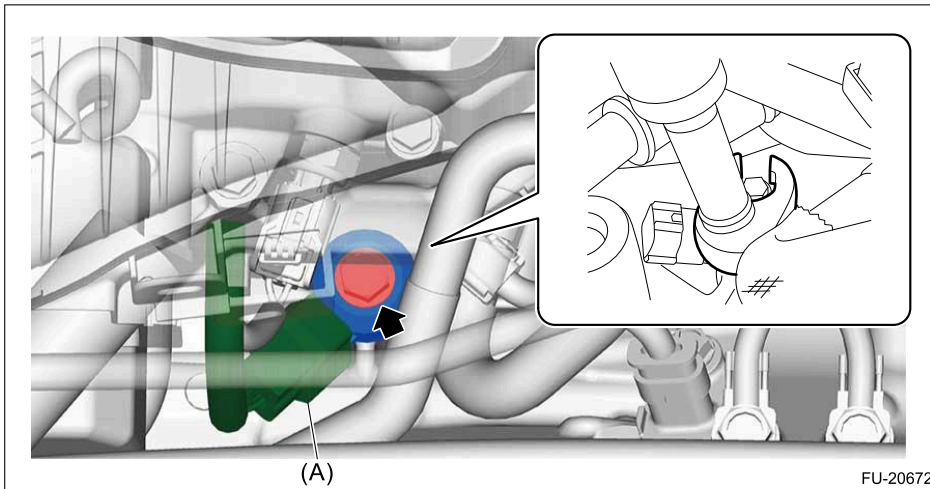
Note:

If the effective length of the tool used is unknown, consult the manufacturer of the tool.

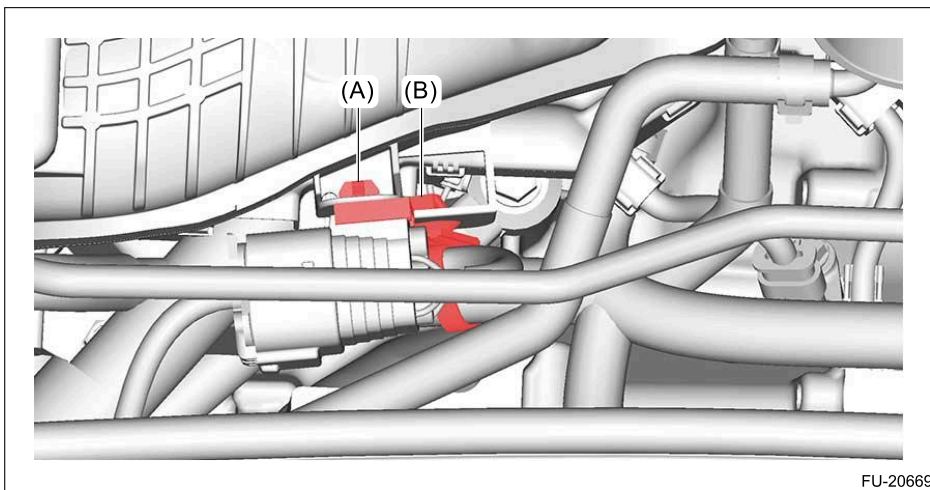


ME-20811

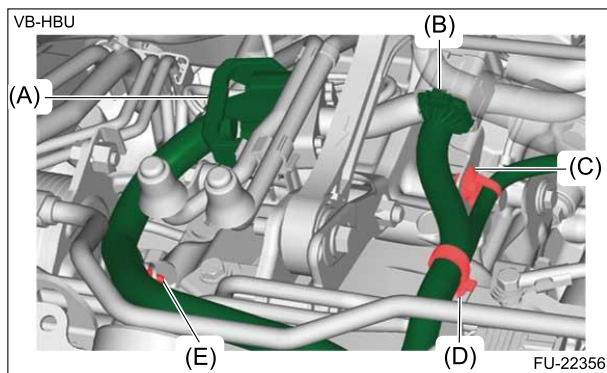
- (a) Effective length of the crowfoot wrench (L2)
- (b) Effective length of the torque wrench (L1)
- (c) Center of the open end of crowfoot wrench
- (d) Center of drive square of the torque wrench
- (e) Center of the position where a force is applied by hand



2. Install the connector (A) and clip (B).



3. Install the clip (C), clip (D) and clip (E), and connect connector (A) and connector (B). (CVT model)



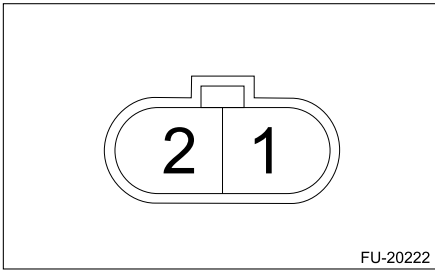
4. Install the intercooler. [Ref. to INTAKE \(INDUCTION\)\(H4DOTC\)>Intercooler>INSTALLATION.](#)

5. Connect the ground terminal to battery sensor. [Ref. to REPAIR CONTENTS>NOTE > BATTERY.](#)

FUEL INJECTION (FUEL SYSTEMS)(H4DOTC) > Knock Sensor

INSPECTION

1. Check that the knock sensor has no deformation, cracks or other damages.
2. Measure the resistance between knock sensor terminals.



FU-20222



Terminal No.	Standard
1 – 2	532 – 588 kΩ

FUEL INJECTION (FUEL SYSTEMS)(H4DOTC) > Throttle Position Sensor

SPECIFICATION


The throttle body cannot be disassembled.

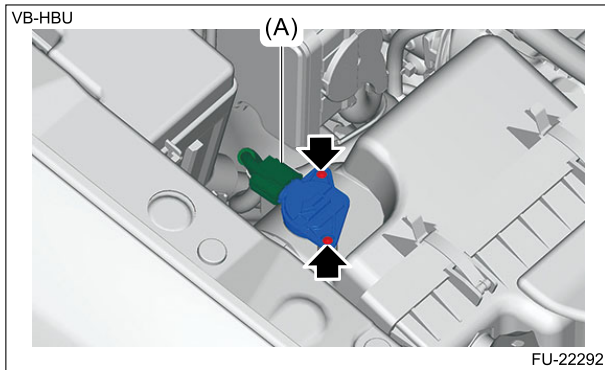
Refer to "Throttle Body" for removal and installation procedure.

-  [Ref. to FUEL INJECTION \(FUEL SYSTEMS\)\(H4DOTC\)>Throttle Body>REMOVAL.](#)
-  [Ref. to FUEL INJECTION \(FUEL SYSTEMS\)\(H4DOTC\)>Throttle Body>INSTALLATION.](#)

FUEL INJECTION (FUEL SYSTEMS)(H4DOTC) > Mass Air Flow and Intake Air Temperature Sensor

REMOVAL

1. Disconnect the ground terminal from battery sensor.  [Ref. to REPAIR CONTENTS>NOTE > BATTERY.](#)
2. Disconnect the connector (A) and remove the mass air flow and intake air temperature sensor.



FUEL INJECTION (FUEL SYSTEMS)(H4DOTC) > Mass Air Flow and Intake Air Temperature Sensor

INSTALLATION

1. Install the mass air flow and intake air temperature sensor, and connect the connector.

Caution:

- If the mass air flow and intake air temperature sensor is reused, check the O-ring and install it so that it is not damaged or pinched.
- If the O-ring is faulty, replace the mass air flow and intake air temperature sensor with a new one.

Tightening torque:


1 N·m (0.1 kgf-m, 0.7 ft-lb)

2. Connect the ground terminal to battery sensor.  [Ref. to REPAIR CONTENTS>NOTE > BATTERY.](#)

FUEL INJECTION (FUEL SYSTEMS)(H4DOTC) > Mass Air Flow and Intake Air Temperature Sensor

INSPECTION

1. CHECK THE MASS AIR FLOW SENSOR UNIT

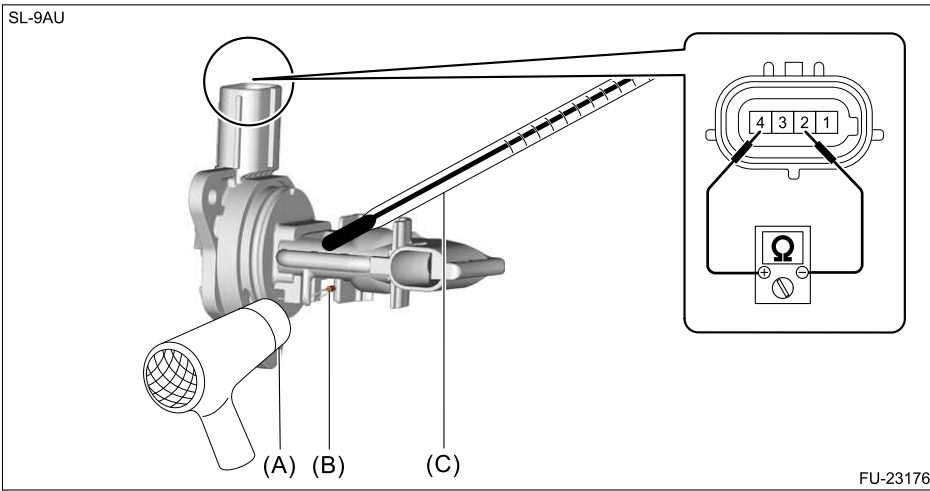
1. Use Subaru Select Monitor and read the intake air amount at each engine speed, and check whether it is within the standard values.  [Ref. to ENGINE \(DIAGNOSTICS\)\(H4DOTC\)>Data Monitor.](#)

Engine speed	Standard
At 0 r/min (Ignition switch ON (engine OFF))	0.5 – 2 g/s (0.1 – 0.3 lb/min)
While idling (Engine fully warmed up, A/C and other electric loads OFF)	2 – 5 g/s (0.3 – 0.7 lb/min)
At 2000 r/min	5 – 10 g/s (0.7 – 1.3 lb/min)

2. CHECK THE INTAKE AIR TEMPERATURE SENSOR UNIT

Raise the temperature gradually, measure the resistance between the air flow and intake air temperature sensor terminals when the temperature is 20°C (68°F) and 60°C (140°F).

SL-9AU



FU-23176

(A) Drier (B) Intake air temperature sensor (C) Thermometer unit

Temperature	Terminal No.	Standard
20°C (68°F)	2 - 4	2.21 - 2.69 kΩ
60°C (140°F)		0.493 - 0.667 kΩ

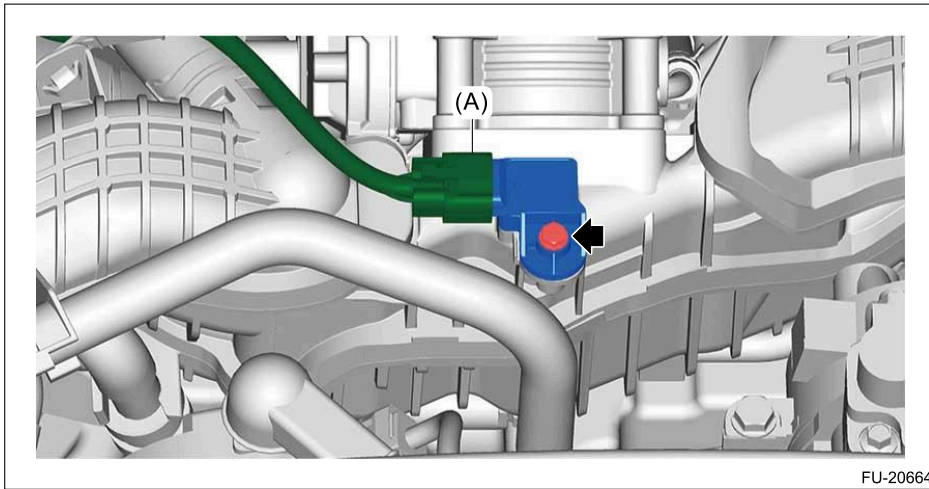
3. OTHER INSPECTIONS

1. Check that the mass air flow and intake air temperature sensor has no deformation, cracks or other damages.
2. Check that the mass air flow and intake air temperature sensor has no dirt.

FUEL INJECTION (FUEL SYSTEMS)(H4DOTC) > Manifold Absolute Pressure and Intake Air Temperature Sensor


REMOVAL

1. Disconnect the ground terminal from battery sensor.  [Ref. to REPAIR CONTENTS>NOTE > BATTERY.](#)
2. Disconnect the connector (A) and remove the manifold absolute pressure and intake air temperature sensor.



FUEL INJECTION (FUEL SYSTEMS)(H4DOTC) > Manifold Absolute Pressure and Intake Air Temperature Sensor

INSTALLATION

1. Install the manifold absolute pressure and intake air temperature sensor.
Tightening torque:
3.4 N·m (0.3 kgf-m, 2.5 ft-lb)
2. Connect the connector.
3. Connect the ground terminal to battery sensor.  [Ref. to REPAIR CONTENTS>NOTE > BATTERY.](#)

FUEL INJECTION (FUEL SYSTEMS)(H4DOTC) > Manifold Absolute Pressure and Intake Air Temperature Sensor

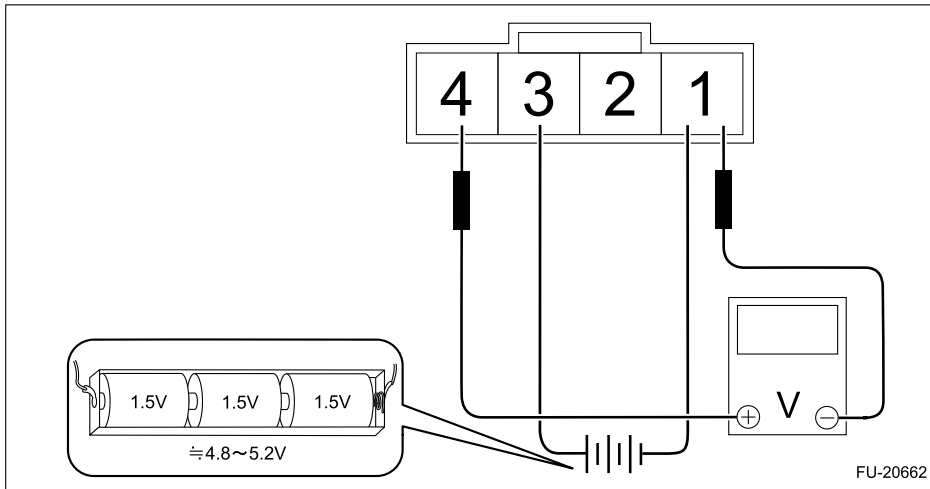
INSPECTION

1. CHECK MANIFOLD ABSOLUTE PRESSURE SENSOR

1. Connect the dry-cell battery positive terminal to terminal No. 3 and the dry-cell battery negative terminal to terminal No. 1, and connect the circuit tester positive terminal to terminal No. 4 and the circuit tester negative terminal to terminal No. 1.

Note:

- Use new dry-cell batteries.
- Using a circuit tester, check that the initial voltage of each dry-cell battery is 1.6 V or more. And also check that the voltage of three batteries in series is between 4.8 – 5.2 V.
- For power supply, 5 V DC constant voltage power source can also be used.



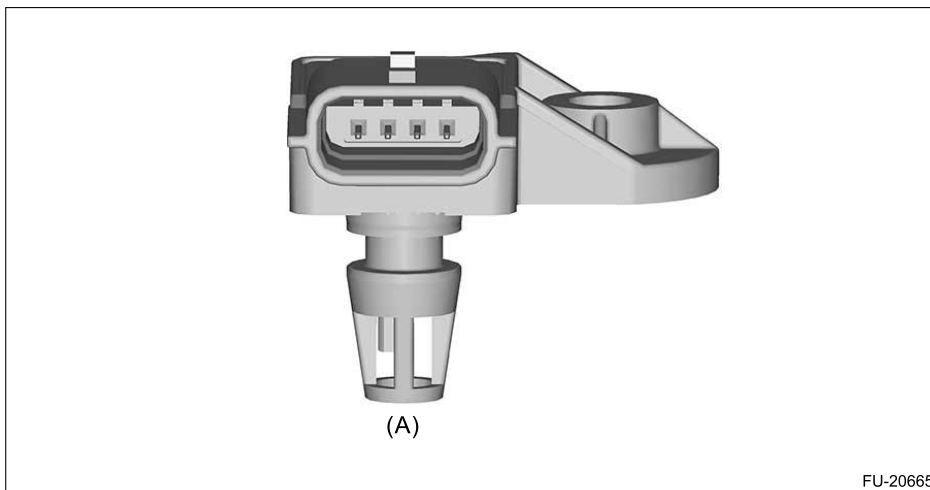
2. Check the voltage at a normal atmospheric pressure.

Note:

The atmospheric pressure at higher altitude is lower than normal. Therefore, the voltage is lower than the standard value.

Terminal No.	Standard
4 (+) – 1 (-)	Approx. 1.7 V (when 25°C (77°F))

3. Connect the Mighty Vac to the pressure port (A).



4. Check the voltage when generating vacuum and positive pressure using Mighty Vac.

Caution:

Do not apply a vacuum that exceeds -88 kPa (-0.9 kg/cm^2 , -12.8 psi). Doing so may damage the manifold pressure and intake air temperature sensor.

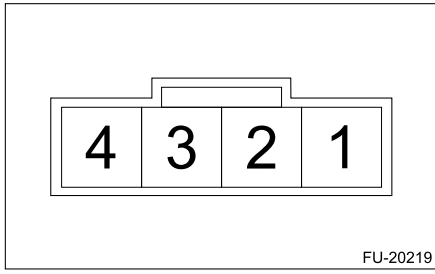
Note:

When vacuum pressure occurs at the pressure port, the voltage will drop from the value as in step 2. When positive pressure occurs, on the other hand, the voltage will rise.

Pressure	Terminal No.	Standard
-88 kPa (-0.9 kg/cm^2 , -12.8 psi)	4 (+) – 1 (-)	Approx. 0.4 V (when 25°C (77°F))

2. CHECK MANIFOLD TEMPERATURE SENSOR UNIT

1. Check the resistance between the terminals at the manifold temperature sensor.



Temperature	Terminal No.	Standard
-20°C (-4°F)	1 – 2	14.7 – 16.1 kΩ
25°C (77°F)		1.9 – 2.1 kΩ
60°C (140°F)		0.5 – 0.6 kΩ

3. OTHER INSPECTIONS

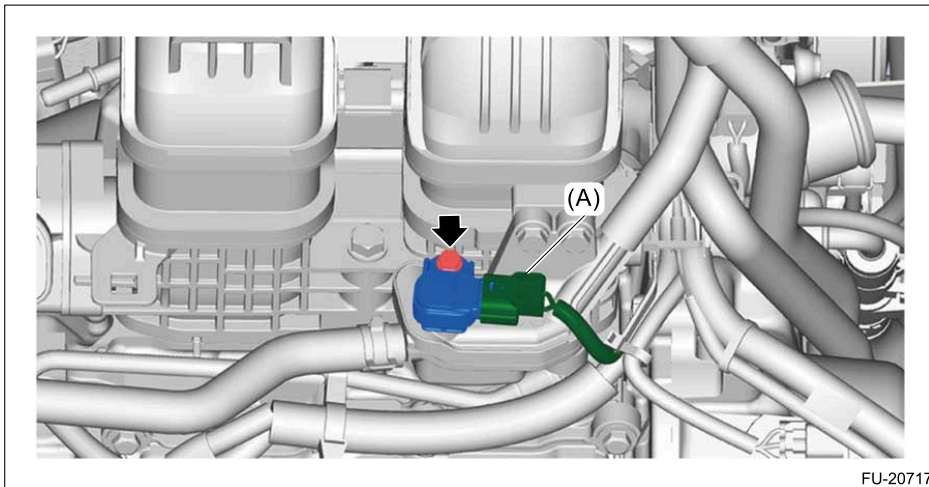
Check that the manifold absolute pressure & intake air temperature sensor has no deformation, cracks or other damages.

FUEL INJECTION (FUEL SYSTEMS)(H4DOTC) > CPC Pressure Sensor

REMOVAL



1. Disconnect the ground terminal from battery sensor. [Ref. to REPAIR CONTENTS>NOTE > BATTERY.](#)
2. Remove the intercooler. [Ref. to INTAKE \(INDUCTION\)\(H4DOTC\)>Intercooler>REMOVAL.](#)
3. Remove the intake duct No. 2. [Ref. to INTAKE \(INDUCTION\)\(H4DOTC\)>Intake Duct>REMOVAL > INTAKE DUCT NO. 2.](#)
4. Disconnect the connector (A) and remove the CPC pressure sensor.



FUEL INJECTION (FUEL SYSTEMS)(H4DOTC) > CPC Pressure Sensor

INSTALLATION

1. Using a new O-ring, install the CPC pressure sensor.
Tightening torque:
3.4 N·m (0.3 kgf-m, 2.5 ft-lb)
2. Connect the connector.
3. Install the intake duct No. 2. [Ref. to INTAKE \(INDUCTION\)\(H4DOTC\)>Intake Duct>INSTALLATION > INTAKE DUCT NO. 2.](#)
4. Install the intercooler. [Ref. to INTAKE \(INDUCTION\)\(H4DOTC\)>Intercooler>INSTALLATION.](#)
5. Connect the ground terminal to battery sensor. [Ref. to REPAIR CONTENTS>NOTE > BATTERY.](#)

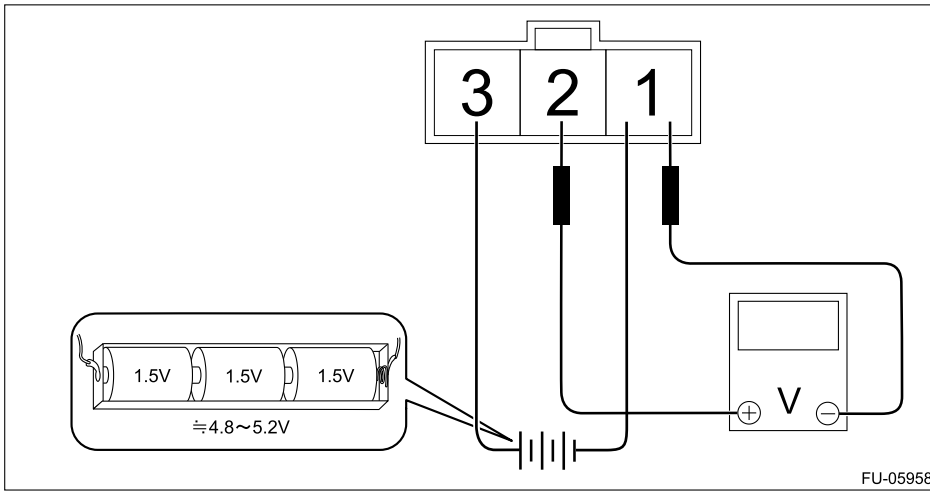
FUEL INJECTION (FUEL SYSTEMS)(H4DOTC) > CPC Pressure Sensor

INSPECTION

1. Check that the CPC pressure sensor has no deformation, cracks or other damages.
2. Connect the dry-cell battery positive terminal to terminal No. 3 and the dry-cell battery negative terminal to terminal No. 1, and connect the circuit tester positive terminal to terminal No. 2 and the circuit tester negative terminal to terminal No. 1.

Note:

- Use new dry-cell batteries.
- Using a circuit tester, check that the initial voltage of each dry-cell battery is 1.6 V or more. And also check that the voltage of three batteries in series is between 4.8 – 5.2 V.
- For power supply, 5 V DC constant voltage power source can also be used.



FU-05958

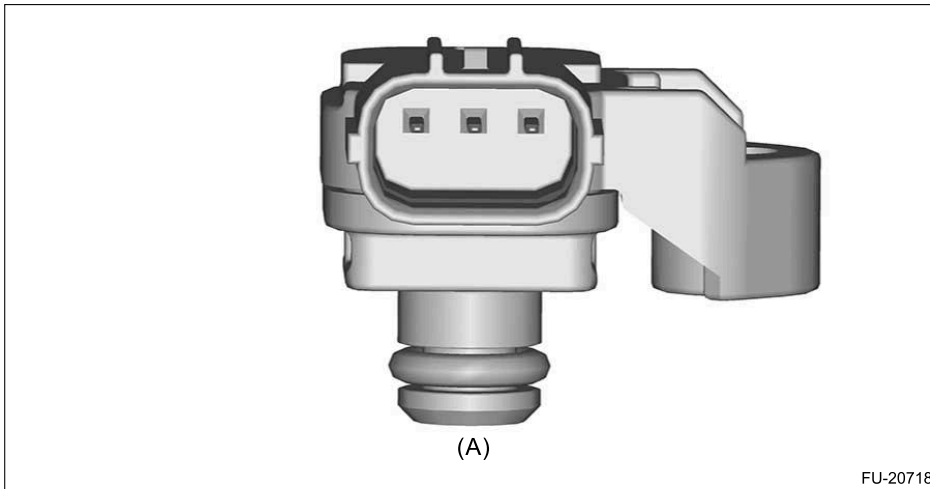
3. Check the voltage at a normal atmospheric pressure.

Note:

The atmospheric pressure at higher altitude is lower than normal. Therefore, the voltage is lower than the standard value.

Terminal No.	Standard
2 (+) – 1 (-)	Approx. 3.6 V (when 25°C (77°F))

4. Connect the Mighty Vac to the pressure port (A) of CPC pressure sensor.



FU-20718

5. Check the voltage when generating vacuum using Mighty Vac.

Caution:

Do not apply a vacuum that exceeds -50 kPa (-0.5 kg/cm^2 , -7.2 psi). Doing so may damage the CPC pressure sensor.

Note:

When vacuum occurs at the pressure port of CPC pressure sensor, the voltage will drop from the value as in step 3.

Pressure	Terminal No.	Standard
-50 kPa (-0.5 kg/cm^2 , -7.2 psi)	2 (+) – 1 (-)	Approx. 2 V (when 25°C (77°F))



FUEL INJECTION (FUEL SYSTEMS)(H4DOTC) > Front Oxygen (A/F) Sensor

REMOVAL



Caution:

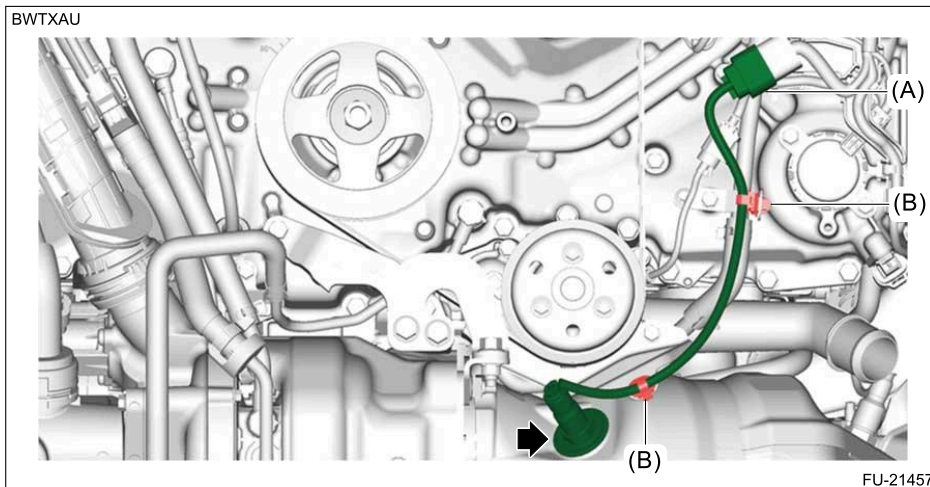
- Vehicle components are extremely hot after driving. Be wary of receiving burns from heated parts.
- When removing the front oxygen (A/F) sensor, wait until exhaust pipe cools, otherwise it will damage the exhaust pipe.

1. Disconnect the ground terminal from battery sensor.  Ref. to [REPAIR CONTENTS>NOTE > BATTERY](#).
2. Lift up the vehicle.
3. Remove the under cover front.  Ref. to [EXTERIOR/INTERIOR TRIM>Front Under Cover>REMOVAL](#).
4. Remove the front oxygen (A/F) sensor.
 - (1) Apply spray-type lubricant to the threaded portion of front oxygen (A/F) sensor, and leave it for one minute or more.

Caution:

In order to prevent smoking and fire, when applying spray-type lubricant, do so only after the exhaust pipe has cooled.

- (2) Disconnect the connector (A) and remove the clip (B).
- (3) Remove the front oxygen (A/F) sensor.



FUEL INJECTION (FUEL SYSTEMS)(H4DOTC) > Front Oxygen (A/F) Sensor

INSTALLATION

Caution:

If lubricant is spilled over the exhaust pipe, wipe it off with cloth to avoid emission of smoke or causing a fire.

1. Install the front oxygen (A/F) sensor.
 - (1) Before installing front oxygen (A/F) sensor, apply anti-seize compound only to the threaded portion of front oxygen (A/F) sensor to make the next removal easier.

Caution:

Never apply anti-seize compound to the protector of front oxygen (A/F) sensor.

Preparation items:

Anti-seize compound: NEVER-SEEZ NSN or equivalent

- (2) Install the front oxygen (A/F) sensor.

Tightening torque:

30 N·m (3.1 kgf-m, 22.1 ft-lb)

- (3) Install the clip, and connect the connector.

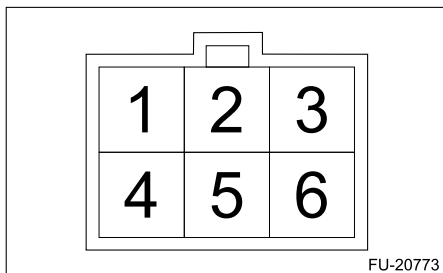
2. Install the under cover front.  Ref. to [EXTERIOR/INTERIOR TRIM>Front Under Cover>INSTALLATION](#).
3. Lower the vehicle.

4. Connect the ground terminal to battery sensor.  [Ref. to REPAIR CONTENTS>NOTE > BATTERY.](#)

FUEL INJECTION (FUEL SYSTEMS)(H4DOTC) > Front Oxygen (A/F) Sensor

INSPECTION

1. Check that the front oxygen (A/F) sensor has no deformation, cracks or other damages.
2. Measure the resistance between front oxygen (A/F) sensor terminals.



Terminal No.	Standard
2 – 3	Approx. 3.5 Ω (when 20°C (68°F))



FUEL INJECTION (FUEL SYSTEMS)(H4DOTC) > Rear Oxygen Sensor

REMOVAL



Caution:

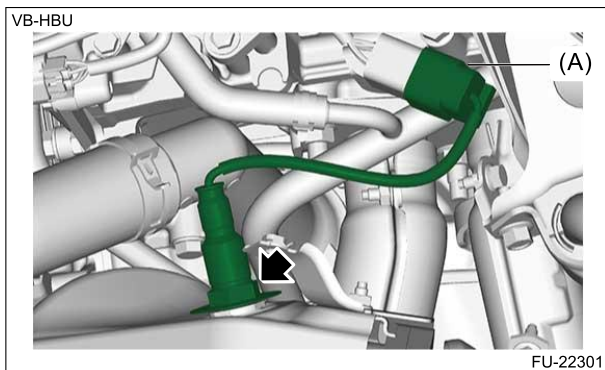
- Vehicle components are extremely hot after driving. Be wary of receiving burns from heated parts.
- When removing the rear oxygen sensor, wait until exhaust pipe cools, otherwise it will damage the exhaust pipe.

1. Disconnect the ground terminal from battery sensor.  [Ref. to REPAIR CONTENTS>NOTE > BATTERY.](#)
2. Lift up the vehicle.
3. Remove the under cover front.  [Ref. to EXTERIOR/INTERIOR TRIM>Front Under Cover>REMOVAL.](#)
4. Remove the rear oxygen sensor.
 - (1) Apply spray-type lubricant to the threaded portion of rear oxygen sensor, and leave it for one minute or more.

Caution:

In order to prevent smoking and fire, when applying spray-type lubricant, do so only after the exhaust pipe has cooled.

- (2) Disconnect the rear oxygen sensor connector (A), and remove the rear oxygen sensor.



FUEL INJECTION (FUEL SYSTEMS)(H4DOTC) > Rear Oxygen Sensor

INSTALLATION

Caution:

If lubricant is spilled over the exhaust pipe, wipe it off with cloth to avoid emission of smoke or causing a fire.

1. Install the rear oxygen sensor.
 - (1) Before installing rear oxygen sensor, apply the anti-seize compound only to the threaded portion of rear oxygen sensor to make the next removal easier.

Caution:

Never apply anti-seize compound to the protector of rear oxygen sensor.

Preparation items:

Anti-seize compound: NEVER-SEEZ NSN or equivalent

- (2) Install the rear oxygen sensor and connect the connector.

Caution:

Do not cross the rear oxygen sensor harness with the ground cord during installation.

Tightening torque:

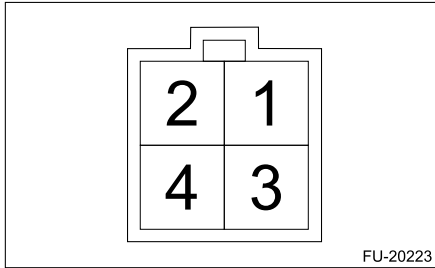
30 N·m (3.1 kgf-m, 22.1 ft-lb)

2. Install the under cover front.  [Ref. to EXTERIOR/INTERIOR TRIM>Front Under Cover>INSTALLATION.](#)
3. Lower the vehicle.
4. Connect the ground terminal to battery sensor.  [Ref. to REPAIR CONTENTS>NOTE > BATTERY.](#)

FUEL INJECTION (FUEL SYSTEMS)(H4DOTC) > Rear Oxygen Sensor

INSPECTION

1. Check that the rear oxygen sensor has no deformation, cracks or other damages.
2. Measure the resistance between rear oxygen sensor terminals.



Terminal No.	Standard
1 – 2	5.4 – 6.6 Ω (at 23°C (73°F))


FUEL INJECTION (FUEL SYSTEMS)(H4DOTC) > SI-DRIVE (SUBARU Intelligent Drive) Selector

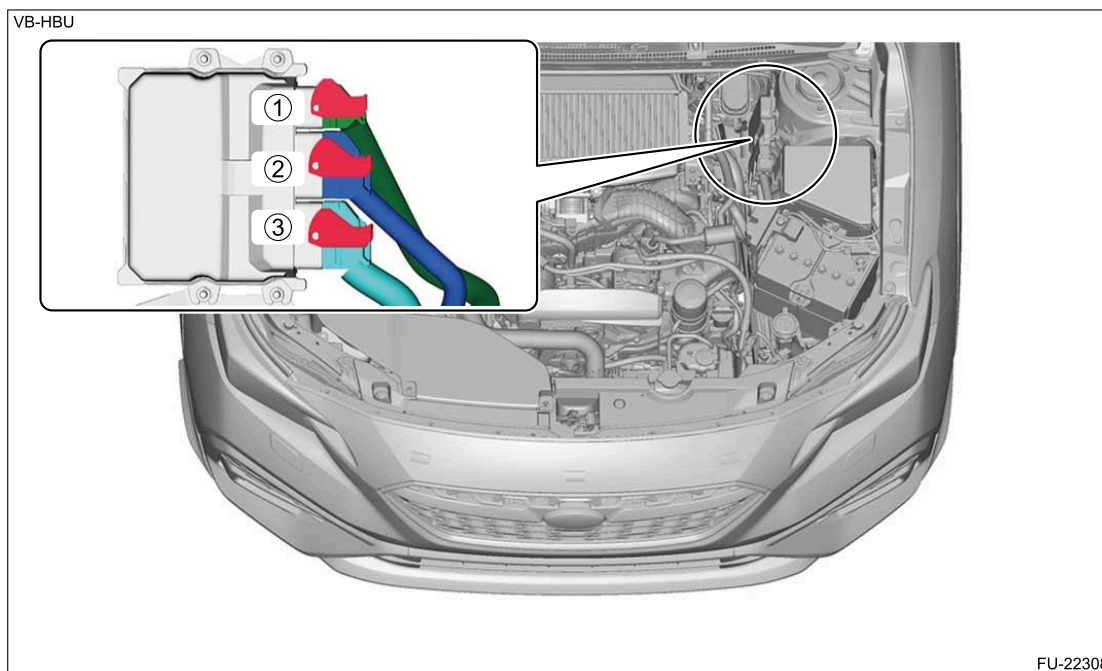
SPECIFICATION

SI-DRIVE (SUBARU Intelligent Drive) selector is integrated as a unit with the EyeSight steering switch.
For removal, installation and inspection, refer to "EyeSight" section.  [Ref. to EyeSight>Steering Switch.](#)

FUEL INJECTION (FUEL SYSTEMS)(H4DOTC) > Engine Control Module (ECM)

REMOVAL

1. Disconnect the ground terminal from battery sensor.  [Ref. to REPAIR CONTENTS>NOTE > BATTERY.](#)
2. Disconnect the connector in numerical order as shown in the figure.



3. Remove the ECM from vehicle.



4. Remove the ECM bracket.



FUEL INJECTION (FUEL SYSTEMS)(H4DOTC) > Engine Control Module (ECM)

INSTALLATION

Caution:

When replacing the ECM, be sure to perform VIN registration, module registration and immobilizer registration after the service.

Note:

When replacing the ECM, be careful not to use the ECM of wrong specification to avoid any damage on the fuel injection system.

1. Install the ECM bracket.

Tightening torque:

7.5 N·m (0.8 kgf-m, 5.5 ft-lb)

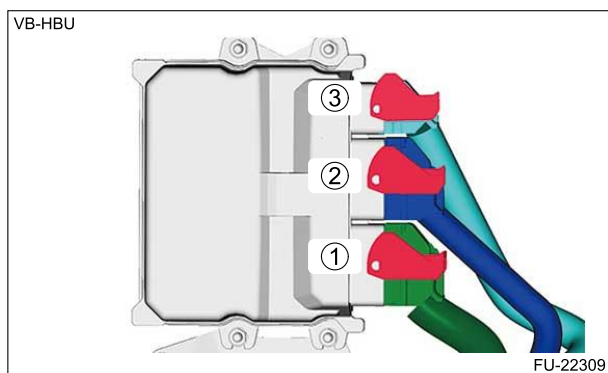
2. Temporarily install the ECM to the vehicle, tighten the fasteners in numerical order as shown in the figure.

Tightening torque:

7.5 N·m (0.8 kgf-m, 5.5 ft-lb)



3. Connect the connector in numerical order as shown in the figure.



4. Connect the ground terminal to battery sensor. [Ref. to REPAIR CONTENTS>NOTE > BATTERY.](#)
5. When the ECM is replaced
 - (1) Perform [Entry VIN]. [Ref. to ENGINE \(DIAGNOSTICS\)\(H4DOTC\)>Work Support>OPERATION.](#)
 - (2) Perform [Module registration]. [Ref. to COMMON \(DIAGNOSTICS\)>Unit Registration>OPERATION.](#)
 - (3) Perform the registration of immobilizer. (Refer to "Type H" described in "REGISTRATION MANUAL FOR IMMOBILIZER".)


FUEL INJECTION (FUEL SYSTEMS)(H4DOTC) > Engine Control Module (ECM)

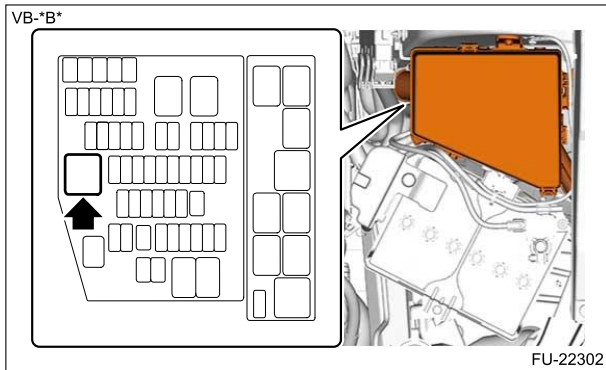
INSPECTION

Check that the ECM has no deformation, cracks or other damages.

FUEL INJECTION (FUEL SYSTEMS)(H4DOTC) > Main Relay

REMOVAL

1. Disconnect the ground terminal from battery sensor.  Ref. to REPAIR CONTENTS>NOTE > BATTERY.
2. Remove the main relay from main fuse box.



FUEL INJECTION (FUEL SYSTEMS)(H4DOTC) > Main Relay

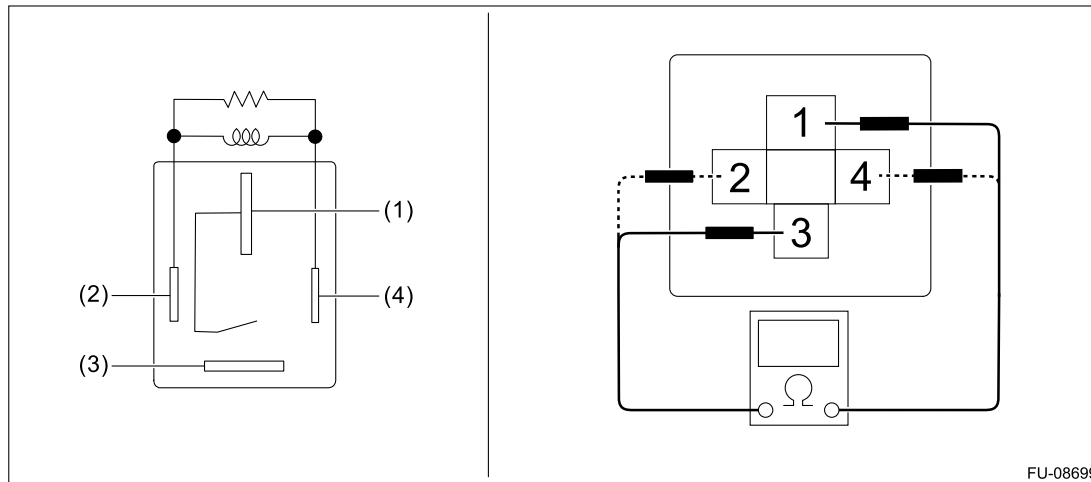
INSTALLATION

1. Install the main relay to the main fuse box.
2. Connect the ground terminal to battery sensor.  Ref. to REPAIR CONTENTS>NOTE > BATTERY.

FUEL INJECTION (FUEL SYSTEMS)(H4DOTC) > Main Relay

INSPECTION

1. Check that the main relay has no deformation, cracks or other damages.
2. Measure the resistance between main relay terminals.




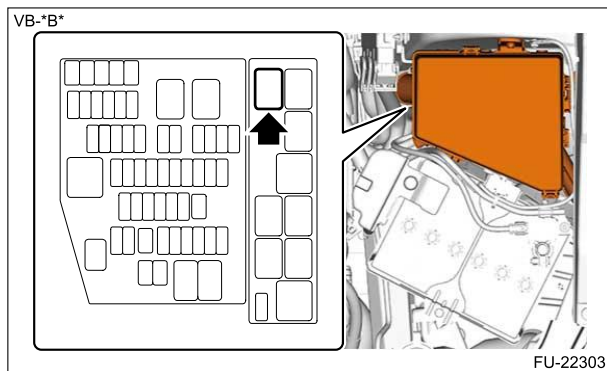
FU-08699

Terminal No.	Inspection conditions	Standard
1 – 3	Always	1 MΩ or more
1 – 3	Apply battery voltage between terminals 2 and 4.	Less than 1 Ω

FUEL INJECTION (FUEL SYSTEMS)(H4DOTC) > Electronic Throttle Control Relay


REMOVAL

1. Disconnect the ground terminal from battery sensor.  [Ref. to REPAIR CONTENTS>NOTE > BATTERY.](#)
2. Remove the electronic throttle control relay from the main fuse box.



FUEL INJECTION (FUEL SYSTEMS)(H4DOTC) > Electronic Throttle Control Relay

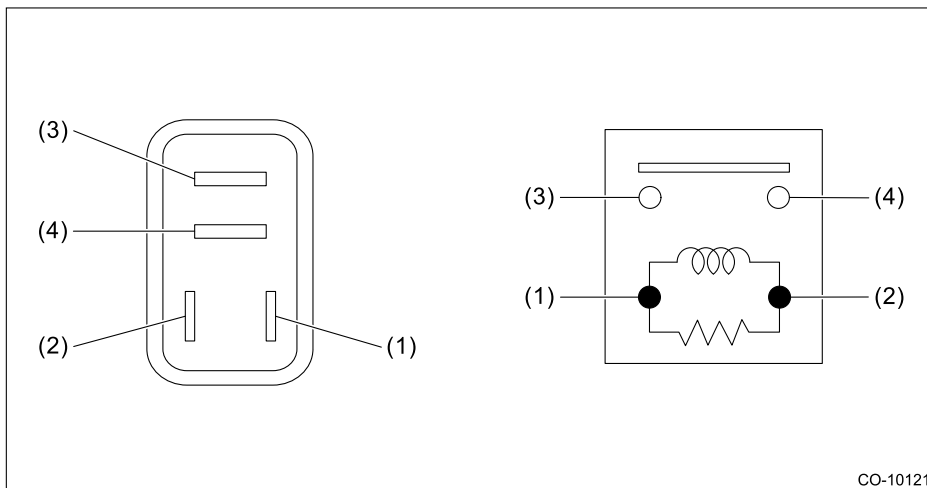
INSTALLATION

1. Install the electronic throttle control relay to the main fuse box.
2. Connect the ground terminal to battery sensor.  [Ref. to REPAIR CONTENTS>NOTE > BATTERY.](#)

FUEL INJECTION (FUEL SYSTEMS)(H4DOTC) > Electronic Throttle Control Relay

INSPECTION

1. Check that the electronic throttle control relay has no deformation, cracks or other damages.
2. Measure the resistance between electronic throttle control relay terminals.




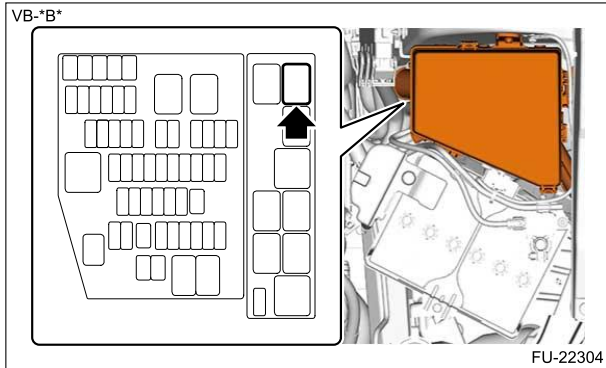
CO-10121

Terminal No.	Inspection conditions	Standard
3 – 4	Always	1 MΩ or more
3 – 4	Apply battery voltage between terminals 1 and 2.	Less than 1 Ω

FUEL INJECTION (FUEL SYSTEMS)(H4DOTC) > Fuel Pump Relay


REMOVAL

1. Disconnect the ground terminal from battery sensor.  [Ref. to REPAIR CONTENTS>NOTE > BATTERY.](#)
2. Remove the fuel pump relay from the main fuse box.



FUEL INJECTION (FUEL SYSTEMS)(H4DOTC) > Fuel Pump Relay

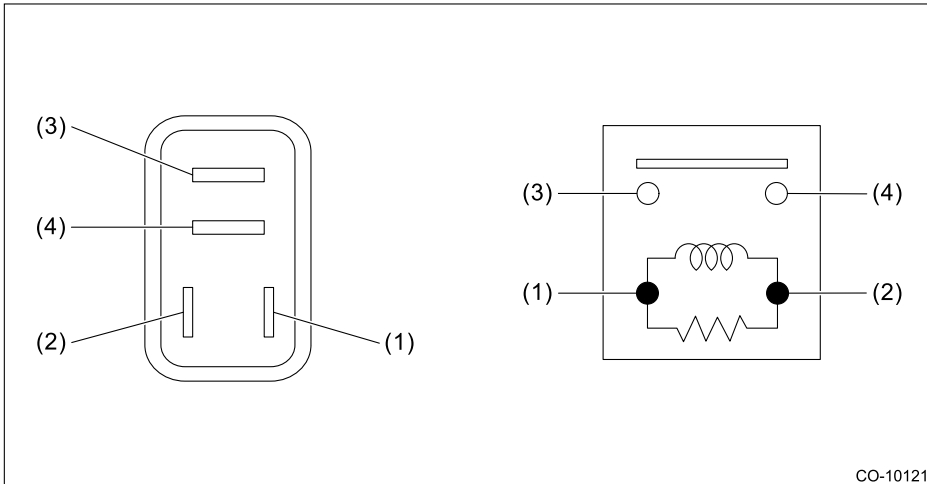
INSTALLATION

1. Install the fuel pump relay to the main fuse box.
2. Connect the ground terminal to battery sensor.  [Ref. to REPAIR CONTENTS>NOTE > BATTERY.](#)

FUEL INJECTION (FUEL SYSTEMS)(H4DOTC) > Fuel Pump Relay

INSPECTION

1. Check that the fuel pump relay has no deformation, cracks or other damages.
2. Measure the resistance between fuel pump relay terminals.

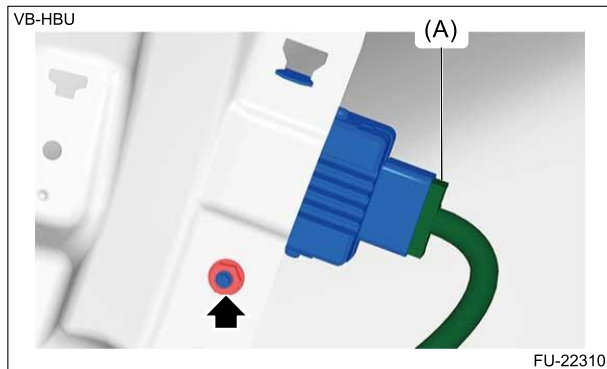


Terminal No.	Inspection conditions	Standard
3 – 4	Always	1 MΩ or more
3 – 4	Apply battery voltage between terminals 1 and 2.	Less than 1 Ω

FUEL INJECTION (FUEL SYSTEMS)(H4DOTC) > Fuel Pump Control Unit

REMOVAL

1. Disconnect the ground terminal from battery sensor. [🔧 Ref. to REPAIR CONTENTS>NOTE > BATTERY.](#)
2. Remove the trim panel trunk side RH. [🔧 Ref. to EXTERIOR/INTERIOR TRIM>Trunk Room Trim>REMOVAL.](#)
3. Disconnect the connector (A), and remove the fuel pump control unit.



FUEL INJECTION (FUEL SYSTEMS)(H4DOTC) > Fuel Pump Control Unit

INSTALLATION

1. Install the fuel pump control module, and connect the connector.
Tightening torque:
5 N·m (0.5 kgf-m, 3.7 ft-lb)
2. Install the trim panel trunk side RH. [🔧 Ref. to EXTERIOR/INTERIOR TRIM>Trunk Room Trim>INSTALLATION.](#)
3. Connect the ground terminal to battery sensor. [🔧 Ref. to REPAIR CONTENTS>NOTE > BATTERY.](#)

FUEL INJECTION (FUEL SYSTEMS)(H4DOTC) > Fuel Pump Control Unit

INSPECTION

Check that the fuel pump control unit has no deformation, cracks or other damages.

PROCEDURE

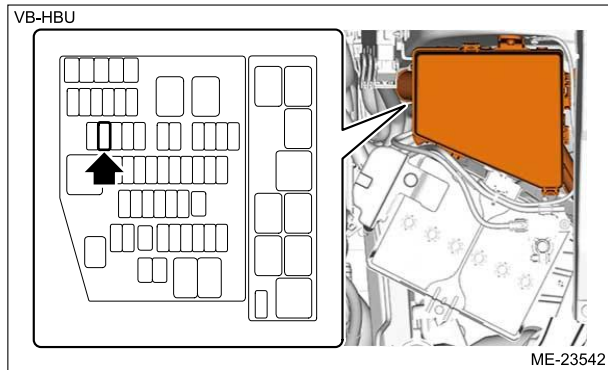


1. RELEASING OF FUEL PRESSURE

Warning:
Place "NO OPEN FLAMES" signs near the working area.

Caution:
Be careful not to spill fuel.

1. Remove the fuse of fuel pump from main fuse box.



2. Start the engine and run it until it stalls.
3. After the engine stalls, crank it for five more seconds.
4. Turn the ignition switch to OFF.
5. Install the fuse of fuel pump to the main fuse box.

2. DRAINING FUEL (WITH SUBARU SELECT MONITOR)

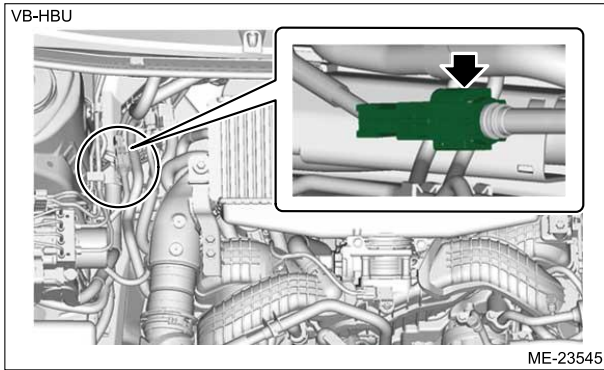
Warning:
Place "NO OPEN FLAMES" signs near the working area.


Caution:
Be careful not to spill fuel.

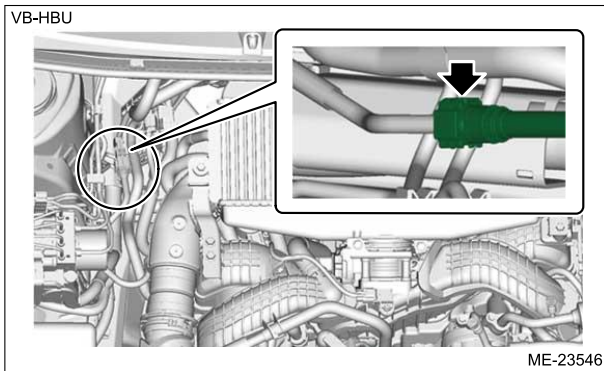
Note:

- If the fuel pump cannot be driven, refer to "DRAINING FUEL (WITH OTHER THAN SUBARU SELECT MONITOR)".
 [Ref. to FUEL INJECTION \(FUEL SYSTEMS\)\(H4DOTC\)>Fuel>PROCEDURE > DRAINING FUEL \(WITH OTHER THAN SUBARU SELECT MONITOR\).](#)
- Be careful not to let the battery run-out.
- Be aware that the fuel may remain in the fuel tank after draining the fuel.

1. Release the fuel pressure. [Ref. to FUEL INJECTION \(FUEL SYSTEMS\)\(H4DOTC\)>Fuel>PROCEDURE > RELEASING OF FUEL PRESSURE.](#)
2. Remove the fuel delivery tube clamp from the fuel delivery tube.



3. Disconnect the quick connector on the fuel delivery tube from the fuel pipe assembly.  [Ref. to FUEL INJECTION \(FUEL SYSTEMS\)\(H4DOTC\)>Fuel Delivery and Evaporation Lines>REMOVAL > QUICK CONNECTOR DISCONNECTION \(TYPE A\).](#)




4. Connect the ST to the fuel pipe assembly.

Note:

The ST is a SUBARU genuine part.

Special tool:

FUEL HOSE (42075AG690)

5. Connect the gasoline proof hose to ST and put the end of the hose in the container.
 6. Drive the fuel pump and drain the fuel using Subaru Select Monitor.  [Ref. to ENGINE \(DIAGNOSTICS\)\(H4DOTC\)>Active Test.](#)

Caution:

- Be careful not to spill fuel.
- Always collect fuel using a dedicated fuel container.

7. Install the related parts in the reverse order after draining the fuel.

Caution:

- Be careful not to spill fuel.
- Catch the fuel from the tubes using a container or cloth.
- Check that there is no damage or dust on the quick connector. If necessary, clean the seal surface of the pipe.
- When connecting the quick connector, make sure to insert it all the way in before locking the slider.
- When it is difficult to lock the slider, check that the connector is fully inserted.
- After locking the slider, pull the quick connector itself to the disconnecting direction, and then push to the connecting direction in order to confirm secure connection. Always make sure to perform this confirmation ending up with a pushing in.

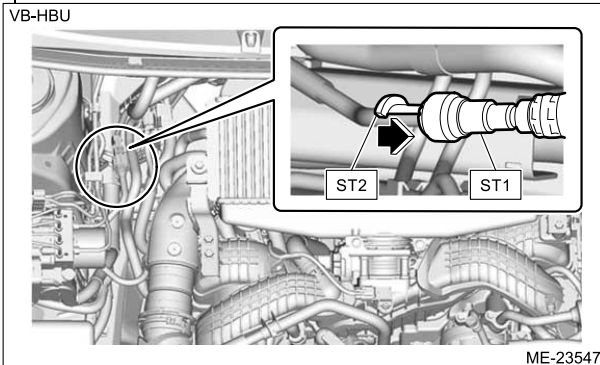
Note:


- When disconnecting the ST1, install the ST2 to the fuel pipe assembly, and press the ST2 in the direction of arrow to disconnect the quick connector on the ST1.

Preparation tool:

ST1: FUEL HOSE (42075AG690)

ST2: QUICK CONNECTOR RELEASE (42099AE000)



- For information about connecting the quick connector on the fuel delivery tube, refer to "Fuel Delivery and Evaporation Lines".  [Ref. to FUEL INJECTION \(FUEL SYSTEMS\)\(H4DOTC\)>Fuel Delivery and Evaporation Lines>INSTALLATION > QUICK CONNECTOR CONNECTION \(TYPE A\).](#)

3. DRAINING FUEL (WITH OTHER THAN SUBARU SELECT MONITOR)

Warning:

Place "NO OPEN FLAMES" signs near the working area.

Caution:

- Be careful not to spill fuel.
- Fuel may remain in the fuel filler pipe. Drain the fuel from the fuel filler pipe through the fill opening using the gasoline proof pump and the gasoline proof hose before the operation.

1. Drain fuel partially.

Note:

Perform this work if the fuel gauge indicates "F".

- (1) Set the vehicle on a lift.
- (2) Open the fuel filler lid and remove the fuel filler cap.
- (3) Drain the fuel from the fuel filler pipe using the gasoline proof pump and the gasoline proof hose.

Caution:

- Be careful not to spill fuel.
- Always collect fuel using a dedicated fuel container.

- a. Mark the location of the specified value of the gasoline proof hose.


Specified value (hose insertion length):

900 mm (35.43 in)

- b. Insert the gasoline proof hose through the fill opening to the marked location.

Caution:

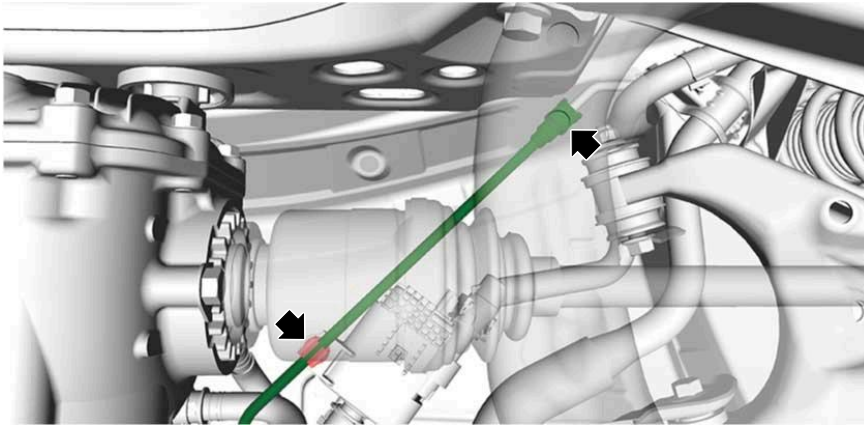
If the hose is inserted into the fuel tank, the check valve may be damaged when pulling out the hose due to getting the hose caught in the check valve. Thus, be careful not to insert the hose more than the specified value.

- c. Drain the fuel from the fuel filler pipe using the gasoline proof pump.
- (4) Lift up the vehicle.
 - (5) Remove the circulate tube from the clip.
 - (6) Set a container under the vehicle, and disconnect the circulate tube from the fuel filler pipe.  [Ref. to FUEL INJECTION \(FUEL SYSTEMS\)\(H4DOTC\)>Fuel Delivery and Evaporation Lines>REMOVAL > QUICK CONNECTOR DISCONNECTION \(TYPE D\).](#)


Caution:

- Be careful not to spill fuel.
- Catch the fuel from fuel filler pipe and circulate tube using a container or cloth.

SK-9BU



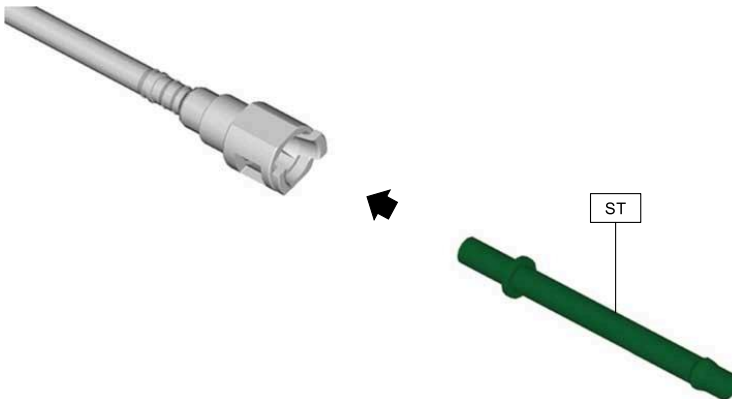
FU-21525

(7) Connect ST to the circulate tube.  Ref. to [FUEL INJECTION \(FUEL SYSTEMS\)\(H4DOTC\)>Fuel Delivery and Evaporation Lines>REMOVAL > QUICK CONNECTOR DISCONNECTION \(TYPE D\)](#).

Preparation tool:

ST: FUEL PIPE ADAPTER (18471AA000)

SK-9BU



FU-21523



(8) Connect the hose of gasoline proof pump to the ST and drain the fuel.

Caution:

- Be careful not to spill fuel.
- Always collect fuel using a dedicated fuel container.

Special tool:

FUEL PIPE ADAPTER (18471AA000)



2. Remove the fuel pump assembly.  Ref. to [FUEL INJECTION \(FUEL SYSTEMS\)\(H4DOTC\)>Fuel Pump Assembly>REMOVAL](#).
3. Remove the fuel sub level sensor.  Ref. to [FUEL INJECTION \(FUEL SYSTEMS\)\(H4DOTC\)>Fuel Sub Level Sensor>REMOVAL](#).
4. Drain the fuel from the fuel tank using the gasoline proof pump.

Caution:

- Be careful not to spill fuel.
- Always collect fuel using a dedicated fuel container.

5. Install the related parts in the reverse order after draining the fuel.

Note:

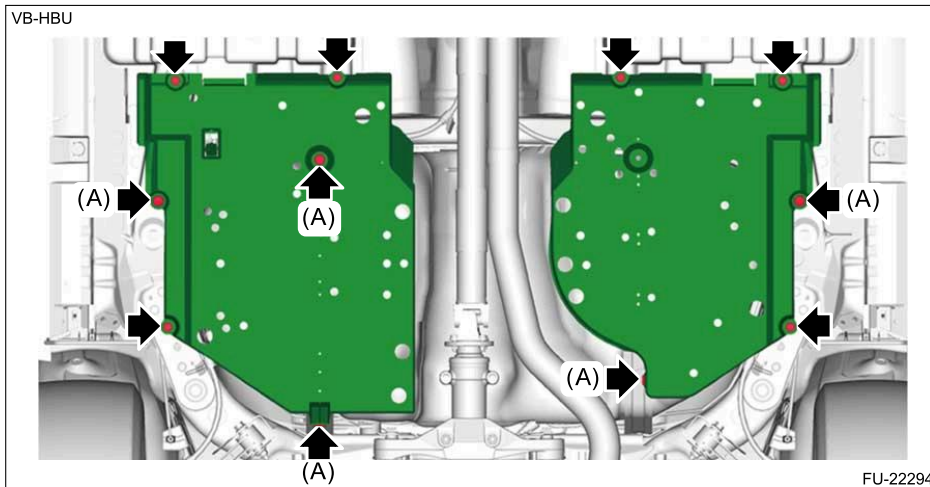
- For information about connecting the quick connector on the circulate tube, refer to "Fuel Delivery and Evaporation Lines".  Ref. to [FUEL INJECTION \(FUEL SYSTEMS\)\(H4DOTC\)>Fuel Delivery and Evaporation Lines>INSTALLATION > QUICK CONNECTOR CONNECTION \(TYPE D\)](#).
- For information about connecting the quick connector on the fuel delivery tube, refer to "Fuel Delivery and Evaporation Lines".  Ref. to [FUEL INJECTION \(FUEL SYSTEMS\)\(H4DOTC\)>Fuel Delivery and Evaporation Lines>INSTALLATION > QUICK CONNECTOR CONNECTION \(TYPE D\)](#).

FUEL INJECTION (FUEL SYSTEMS)(H4DOTC) > Fuel Tank Protector

REMOVAL



1. Lift up the vehicle.
2. Remove the bolt and clip (A) and remove the fuel tank protector.



FUEL INJECTION (FUEL SYSTEMS)(H4DOTC) > Fuel Tank Protector

INSTALLATION

1. Install the fuel tank protector.
Tightening torque:
18 N·m (1.8 kgf-m, 13.3 ft-lb)
2. Lower the vehicle.

FUEL INJECTION (FUEL SYSTEMS)(H4DOTC) > Fuel Tank Protector

INSPECTION

Check that the fuel tank protector has no deformation, cracks or other damages.

REMOVAL



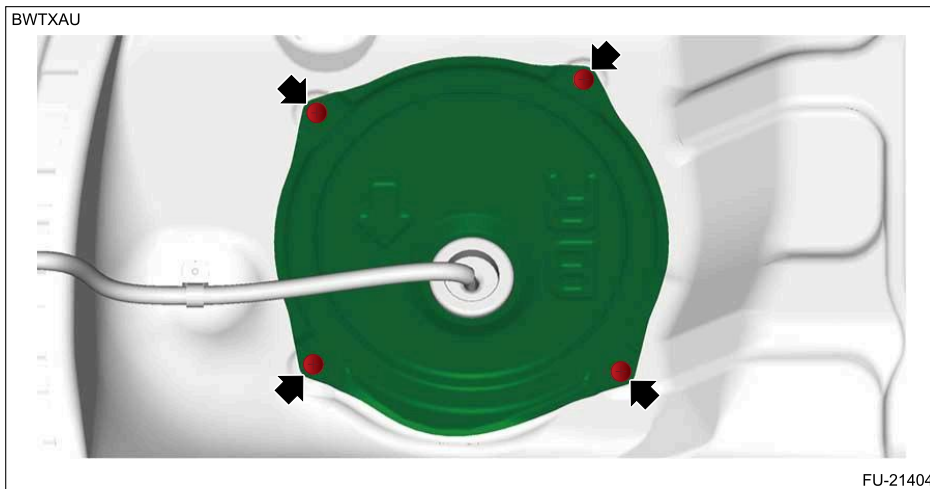
Warning:

Place "NO OPEN FLAMES" signs near the working area.

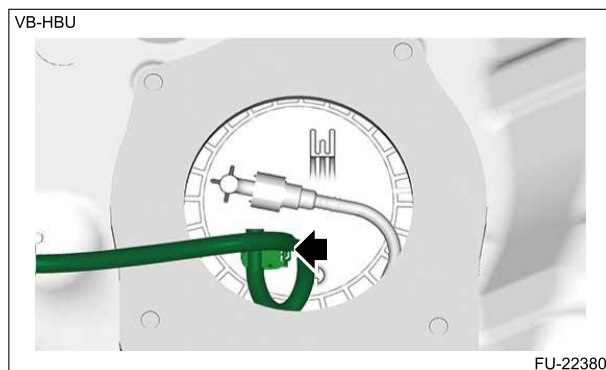
Caution:

- Be careful not to spill fuel.
- Catch the fuel from the tubes using a container or cloth.

1. Release the fuel pressure. [Ref. to FUEL INJECTION \(FUEL SYSTEMS\)\(H4DOTC\)>Fuel>PROCEDURE > RELEASING OF FUEL PRESSURE.](#)
2. Drain fuel. [Ref. to FUEL INJECTION \(FUEL SYSTEMS\)\(H4DOTC\)>Fuel>PROCEDURE > DRAINING FUEL \(WITH SUBARU SELECT MONITOR\).](#)
3. Disconnect the ground terminal from battery sensor. [Ref. to REPAIR CONTENTS>NOTE > BATTERY.](#)
4. Remove the rear seat cushion. [Ref. to SEATS>Rear Seat>REMOVAL.](#)
5. Remove the service hole cover RH.

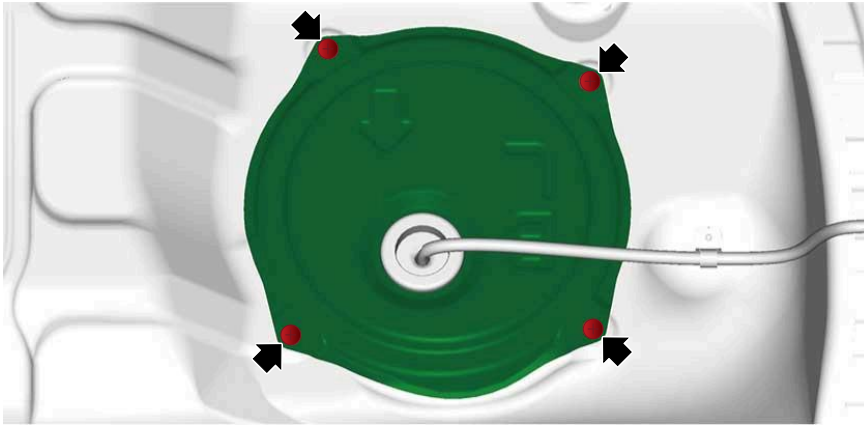


6. Disconnect the connector from fuel pump.



7. Remove the service hole cover LH.

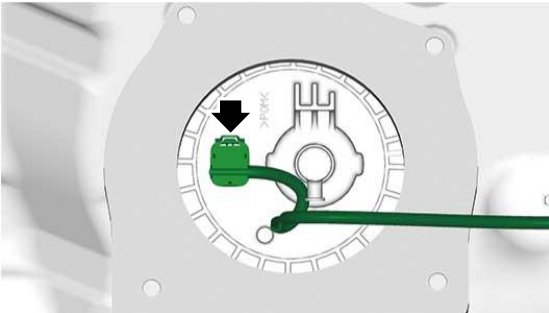
BWTXAU



FU-21406

8. Disconnect the connector from the fuel sub level sensor.

VB-HBU



FU-22381

9. Lift up the vehicle.

10. Remove the fuel tank protector. [Ref. to FUEL INJECTION \(FUEL SYSTEMS\)\(H4DOTC\)>Fuel Tank Protector>REMOVAL.](#)

11. Remove the rear exhaust pipe and muffler as a single unit.

Rear exhaust pipe:

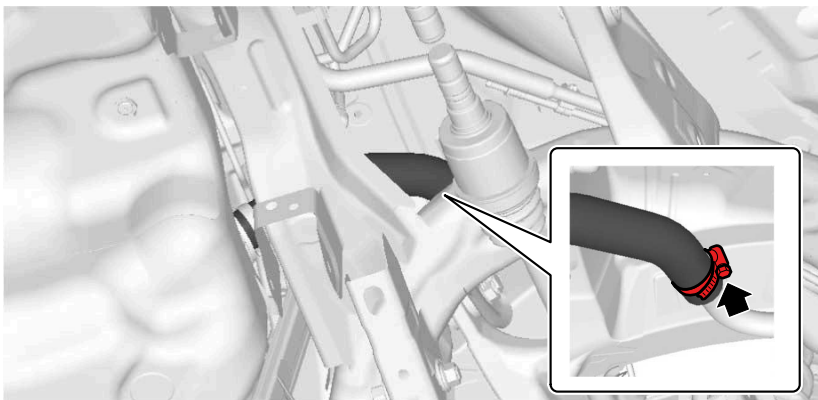
- [Ref. to EXHAUST\(H4DOTC\)>Rear Exhaust Pipe>REMOVAL.](#)

Muffler:

- [Ref. to EXHAUST\(H4DOTC\)>Muffler>REMOVAL.](#)

12. Remove the rear differential. [Ref. to DIFFERENTIALS>Rear Differential \(VB-type\)>REMOVAL.](#)

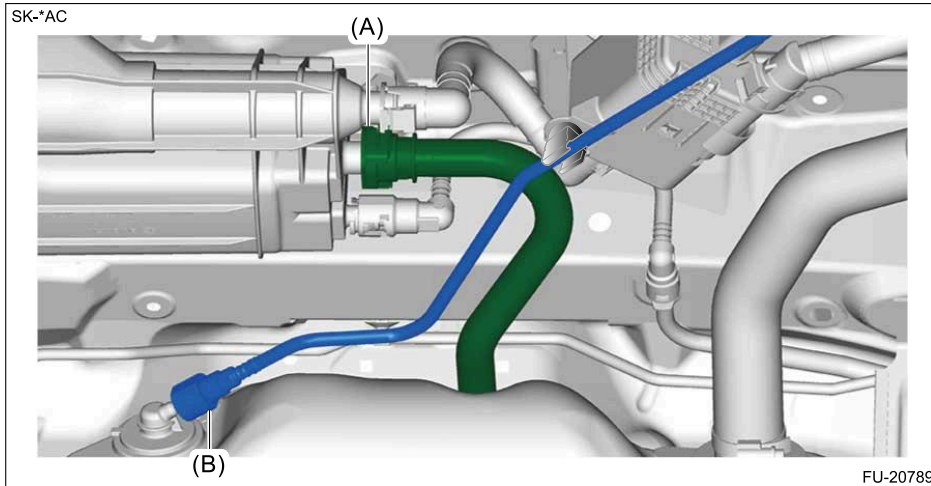
13. Disconnect the fuel filler hose from the fuel filler pipe.



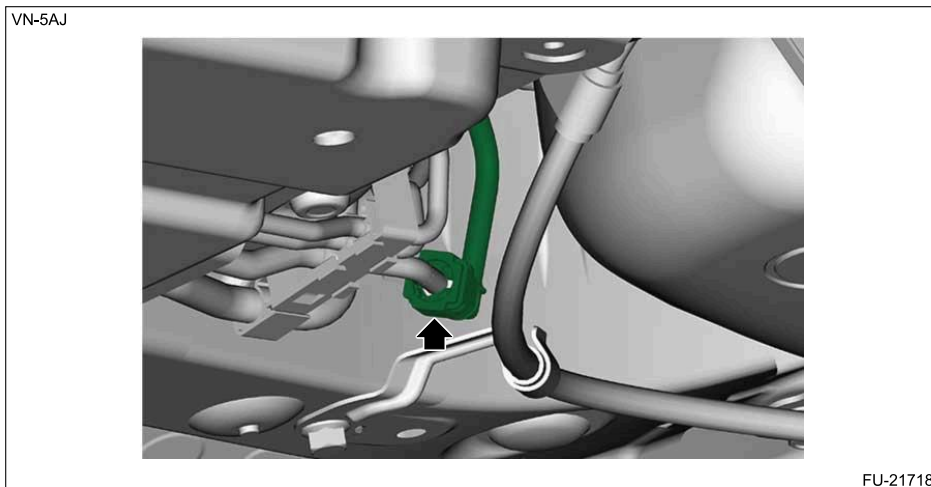
FU-20426

14. Disconnect the vent tube (A) from the canister. [Ref. to FUEL INJECTION \(FUEL SYSTEMS\)\(H4DOTC\)>Fuel Delivery and Evaporation Lines>REMOVAL > QUICK CONNECTOR DISCONNECTION \(TYPE G\).](#)

15. Disconnect the circulate tube (B) from the fuel tank.  Ref. to [FUEL INJECTION \(FUEL SYSTEMS\)\(H4DOTC\)>Fuel Delivery and Evaporation Lines>REMOVAL > QUICK CONNECTOR DISCONNECTION \(TYPE D\)](#).



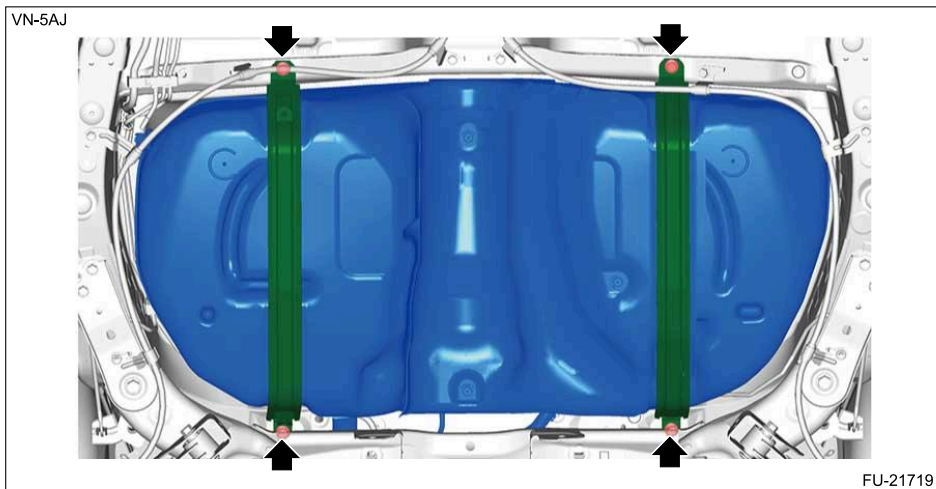
16. Disconnect the fuel delivery tube from the fuel pipe assembly.  Ref. to [FUEL INJECTION \(FUEL SYSTEMS\)\(H4DOTC\)>Fuel Delivery and Evaporation Lines>REMOVAL > QUICK CONNECTOR DISCONNECTION \(TYPE A\)](#).



17. Support the fuel tank with a transmission jack, remove the bolts from the fuel tank band, and remove the fuel tank from the vehicle.

Caution:

- A helper is required to perform this work.
- Fuel may remain in the fuel tank. This will cause the left and right sides to be unbalanced. Be careful not to drop it.



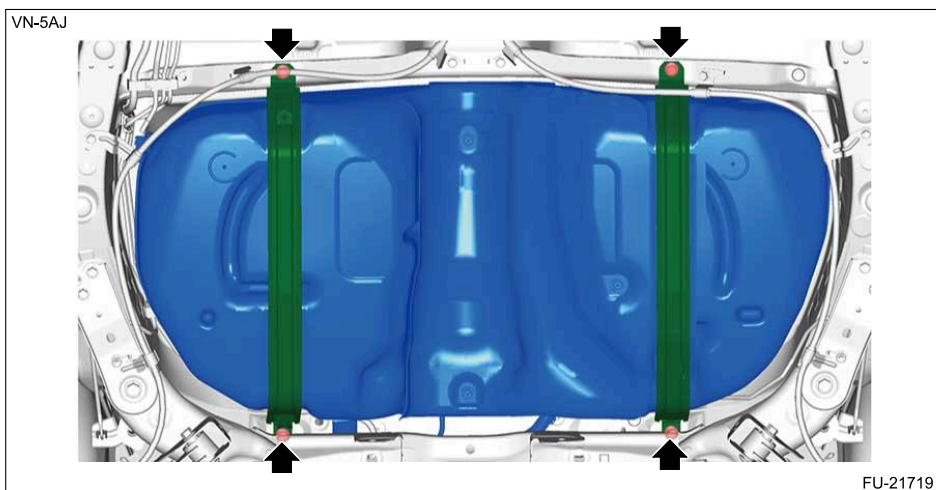
FUEL INJECTION (FUEL SYSTEMS)(H4DOTC) > Fuel Tank

INSTALLATION

1. Support the fuel tank with a transmission jack, set the fuel tank in place, and temporarily tighten the bolts of the fuel tank band.

Caution:

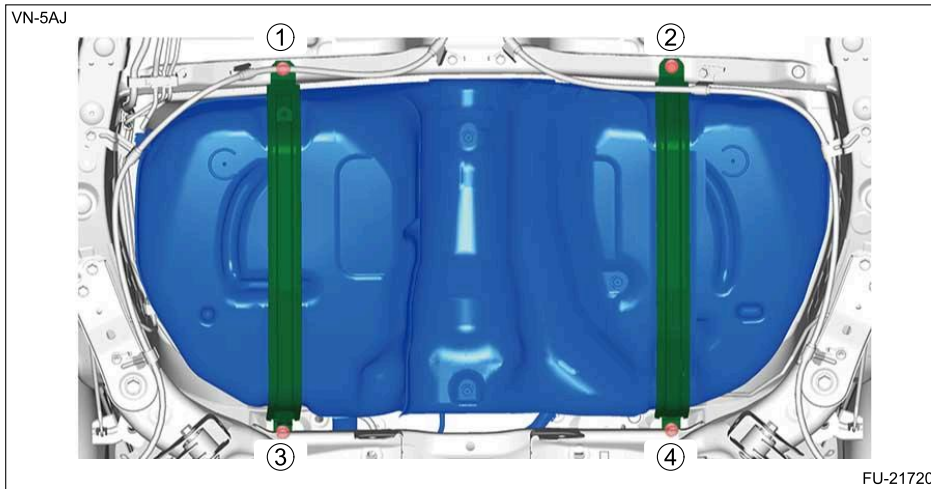
A helper is required to perform this work.



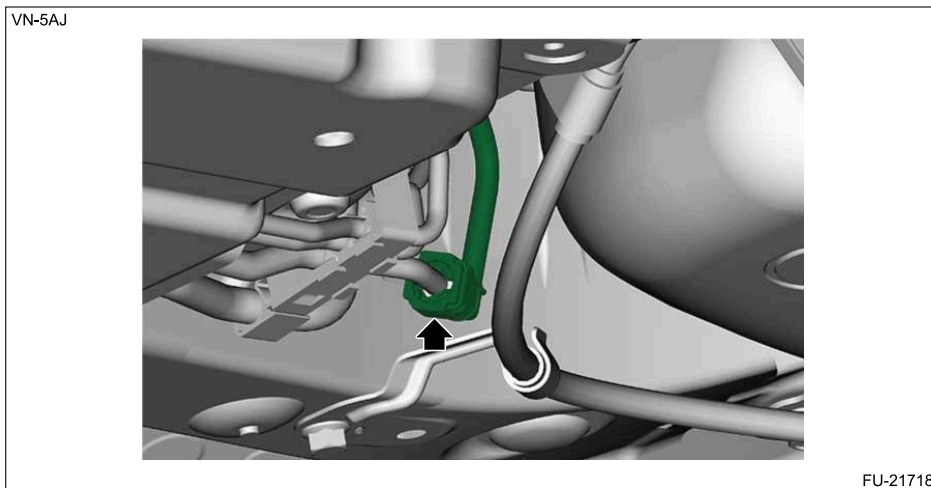
2. Tighten the bolts of the fuel tank band in the numerical order shown in the figure.

Tightening torque:

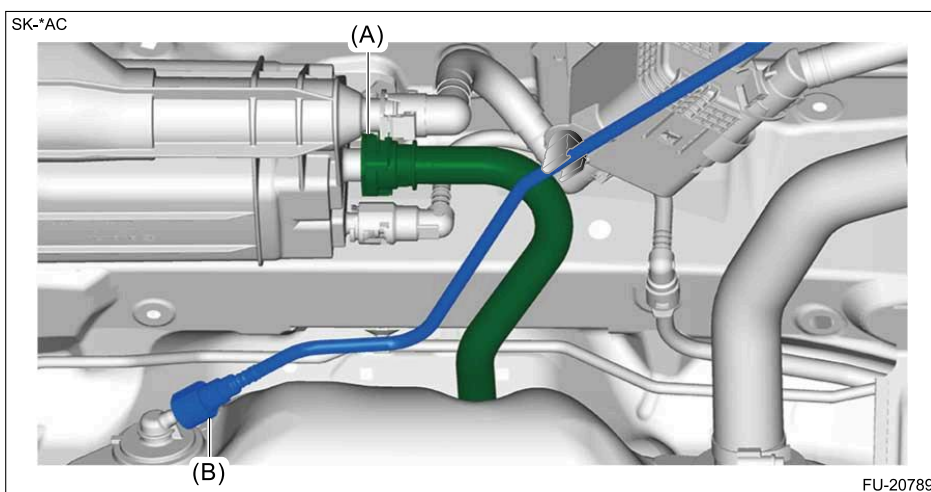
33 N·m (3.4 kgf-m, 24.3 ft-lb)



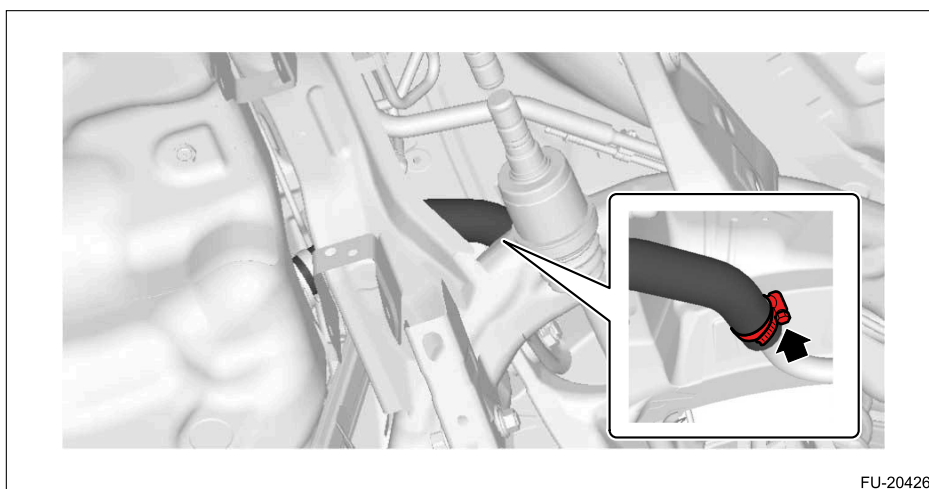
3. Connect the fuel delivery tube to the fuel pipe assembly. [📖 Ref. to FUEL INJECTION \(FUEL SYSTEMS\)\(H4DOTC\)>Fuel Delivery and Evaporation Lines>INSTALLATION > QUICK CONNECTOR CONNECTION \(TYPE A\).](#)



4. Connect the vent tube (A) to the canister. [📖 Ref. to FUEL INJECTION \(FUEL SYSTEMS\)\(H4DOTC\)>Fuel Delivery and Evaporation Lines>INSTALLATION > QUICK CONNECTOR CONNECTION \(TYPE G\).](#)
5. Connect the circulate tube (B) to the fuel tank. [📖 Ref. to FUEL INJECTION \(FUEL SYSTEMS\)\(H4DOTC\)>Fuel Delivery and Evaporation Lines>INSTALLATION > QUICK CONNECTOR CONNECTION \(TYPE D\).](#)



6. Connect the fuel filler hose to the fuel filler pipe. [📖 Ref. to FUEL INJECTION \(FUEL SYSTEMS\)\(H4DOTC\)>Fuel Delivery and Evaporation Lines>INSTALLATION > FUEL FILLER HOSE CONNECTION.](#)



7. Install the rear differential.  [Ref. to DIFFERENTIALS>Rear Differential \(VB-type\)>INSTALLATION.](#)

8. Install the rear exhaust pipe and muffler.

Rear exhaust pipe:

 [Ref. to EXHAUST\(H4DOTC\)>Rear Exhaust Pipe>INSTALLATION.](#)

Muffler:

 [Ref. to EXHAUST\(H4DOTC\)>Muffler>INSTALLATION.](#)

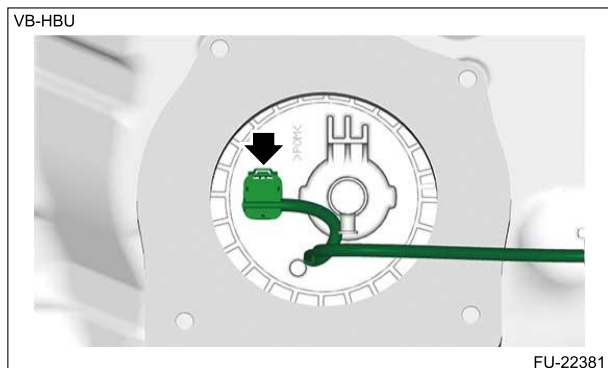
9. Install the fuel tank protector.  [Ref. to FUEL INJECTION \(FUEL SYSTEMS\)\(H4DOTC\)>Fuel Tank Protector>INSTALLATION.](#)

10. Lower the vehicle.

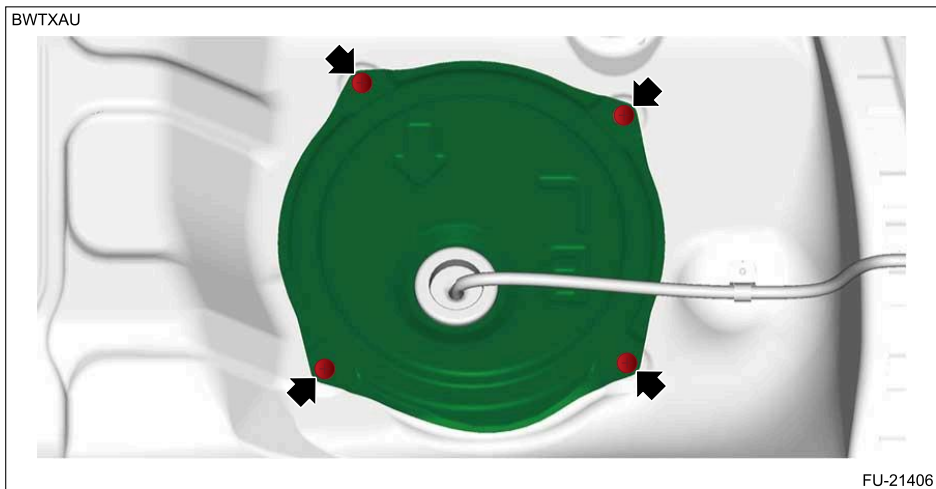
11. Connect the connector to the fuel sub level sensor.

Caution:

Before connecting, make sure that there are no foreign matters, water, etc. inside the connectors of fuel sub level sensor and harness. If any foreign matters, water, etc. are found, remove them with air blow and connect the connector after it has dried completely.



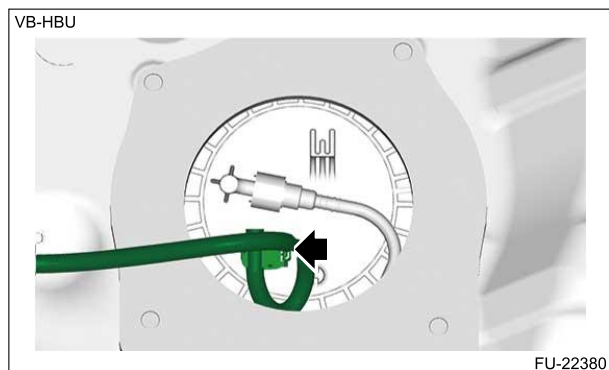
12. Install the service hole cover LH.



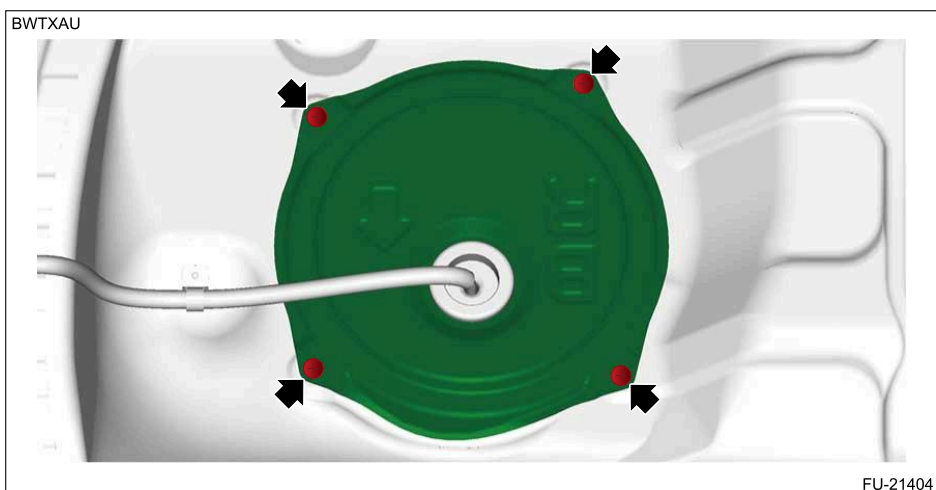
13. Connect the connector to the fuel pump.

Caution:

Before connecting, make sure that there are no foreign matters, water, etc. inside the connectors of fuel pump and harness. If any foreign matters, water, etc. are found, remove them with air blow and connect the connector after it has dried completely.



14. Install the service hole cover RH.



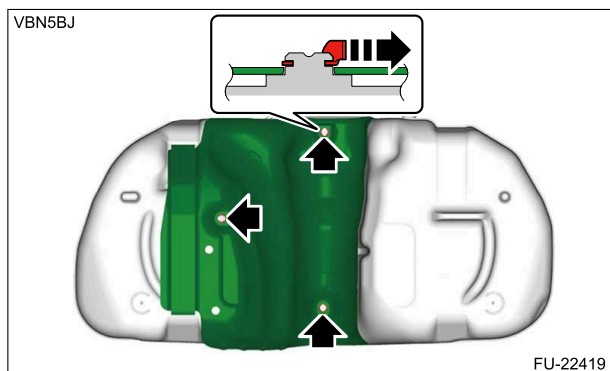
15. Install the rear seat cushion. [📖 Ref. to SEATS>Rear Seat>INSTALLATION.](#)

16. Connect the ground terminal to battery sensor. [📖 Ref. to REPAIR CONTENTS>NOTE > BATTERY.](#)

FUEL INJECTION (FUEL SYSTEMS)(H4DOTC) > Fuel Tank

DISASSEMBLY

1. Remove the hoses from the fuel tank. [Ref. to FUEL INJECTION \(FUEL SYSTEMS\)\(H4DOTC\)>General Description>COMPONENT > FUEL TANK 1.](#)
2. Remove the fuel sub delivery tube. [Ref. to FUEL INJECTION \(FUEL SYSTEMS\)\(H4DOTC\)>Fuel Delivery and Evaporation Lines>REMOVAL.](#)
3. Remove the fuel tank cover from the fuel tank.



FUEL INJECTION (FUEL SYSTEMS)(H4DOTC) > Fuel Tank

ASSEMBLY

1. Install the cushion assembly (A) to the fuel tank. (When replacing with a new part)

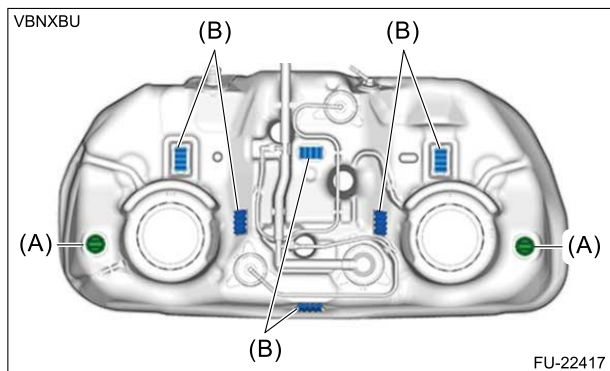
Note:

After installing the cushion assembly, confirm that the claw section on the cushion assembly is securely inserted into the fuel tank.

2. Attach the cushion (B) to the fuel tank. (When replacing with a new part)

Note:

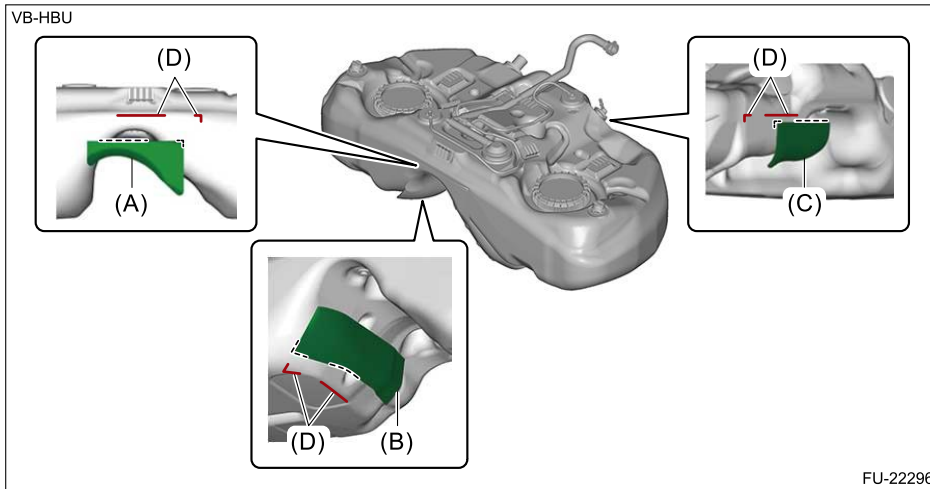
- When replacing the fuel tank with a new one, attach a new cushion before using.
- Before attaching the cushion, degrease the attaching surface of fuel tank.



3. Attach the tank sheet while aligning with the fuel tank positioning mark. (When replacing with a new part)

Note:

- When replacing the fuel tank with a new one, attach a new tank sheet before using.
- Before attaching the tank sheet, degrease the attaching surface of fuel tank.



(A) Tank sheet No. 1

(C) Tank sheet No. 3

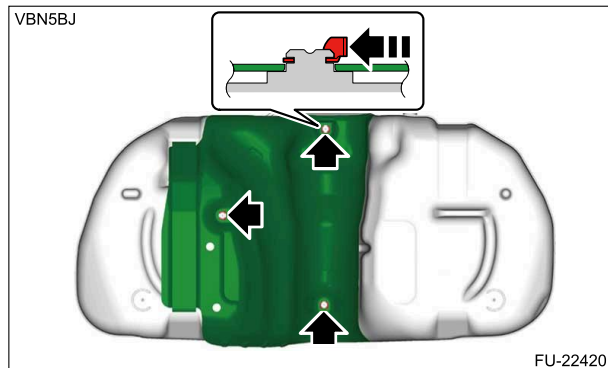
(D) Positioning mark

(B) Tank sheet No. 2

4. Install the fuel tank cover to the fuel tank.

Caution:

Check that the fuel tank cover has no deformation, cracks or other damages. If the fuel tank cover is defective, replace it with a new fuel tank cover.



5. Install the fuel sub delivery tube. [📖 Ref. to FUEL INJECTION \(FUEL SYSTEMS\)\(H4DOTC\)>Fuel Delivery and Evaporation Lines>INSTALLATION.](#)
6. Connect individual hoses to the fuel tank. [📖 Ref. to FUEL INJECTION \(FUEL SYSTEMS\)\(H4DOTC\)>General Description>COMPONENT > FUEL TANK 1.](#)

FUEL INJECTION (FUEL SYSTEMS)(H4DOTC) > Fuel Tank

INSPECTION

1. Check that the fuel tank, fuel tank cover and fuel pipe have no deformation, cracks and other damages.
2. Check that the hose and tube have no cracks, damage or loose part.

FUEL INJECTION (FUEL SYSTEMS)(H4DOTC) > Fuel Filler Cap

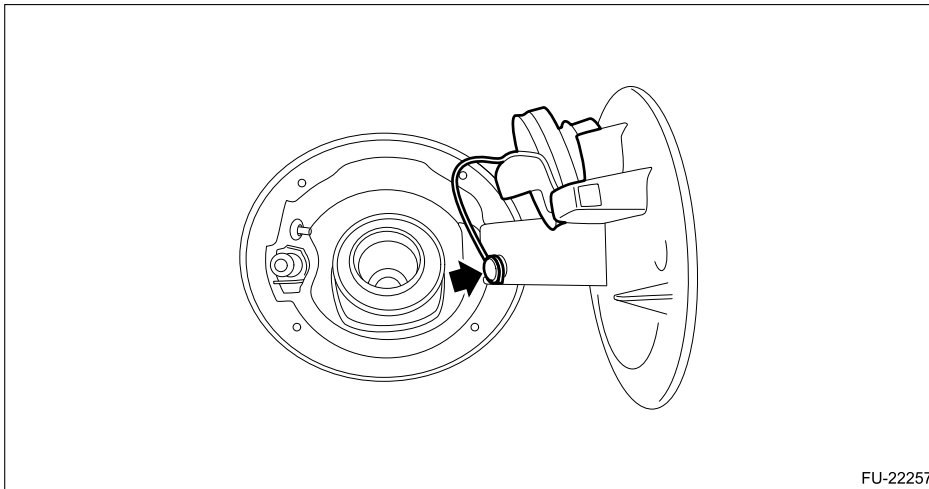
REMOVAL



Warning:

Place **"NO OPEN FLAMES"** signs near the working area.

1. Open the fuel filler lid and remove the fuel filler cap.
2. Remove the clip and remove the fuel filler cap from the filler lid.



FUEL INJECTION (FUEL SYSTEMS)(H4DOTC) > Fuel Filler Cap

INSTALLATION

1. Using a new clip, install the fuel filler cap to the filler lid.
2. Install the fuel filler cap, and close the fuel filler lid.

FUEL INJECTION (FUEL SYSTEMS)(H4DOTC) > Fuel Filler Cap

INSPECTION

Check that the fuel filler cap does not have deformation, cracks or other damages.

REMOVAL



Warning:

Place "NO OPEN FLAMES" signs near the working area.

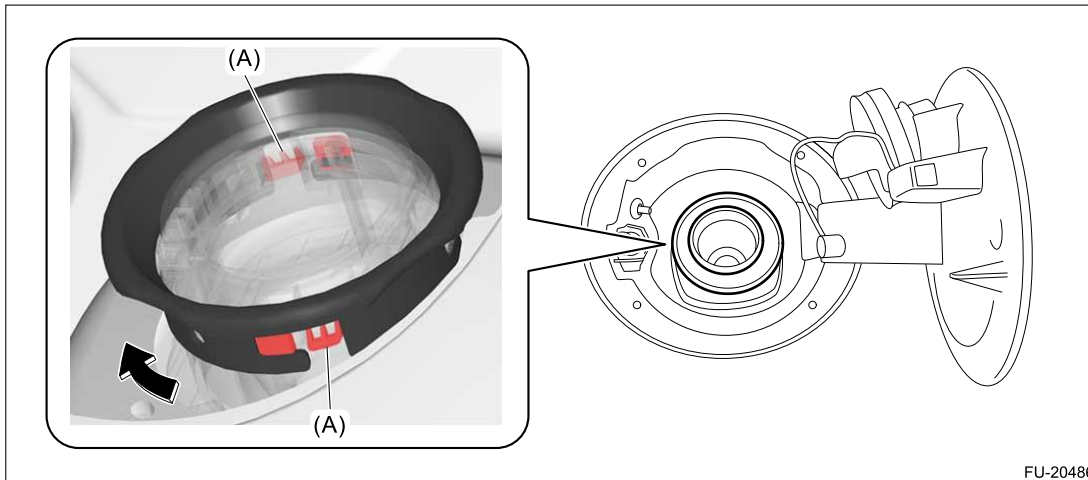
Caution:

Be careful not to spill fuel.

Note:

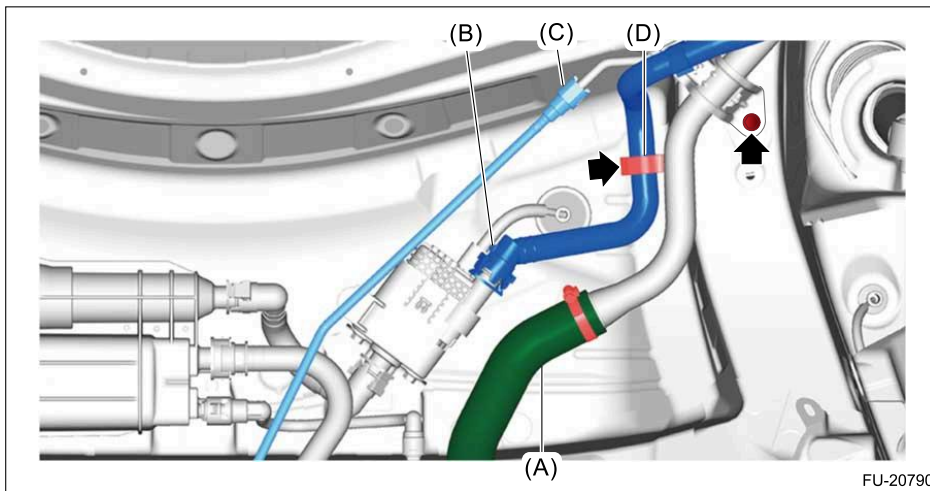
For the removal procedure of fuel filler lid, refer to "Fuel Lid". [Ref. to SECURITY AND LOCKS>Fuel Lid>REMOVAL.](#)

1. Release the fuel pressure. [Ref. to FUEL INJECTION \(FUEL SYSTEMS\)\(H4DOTC\)>Fuel>PROCEDURE > RELEASING OF FUEL PRESSURE.](#)
2. Drain fuel. [Ref. to FUEL INJECTION \(FUEL SYSTEMS\)\(H4DOTC\)>Fuel>PROCEDURE > DRAINING FUEL \(WITH SUBARU SELECT MONITOR\).](#)
3. Open the fuel filler lid and remove the fuel filler cap.
4. Release the lock (A), and turn the fuel filler pipe protector in the direction of the arrow to remove it.

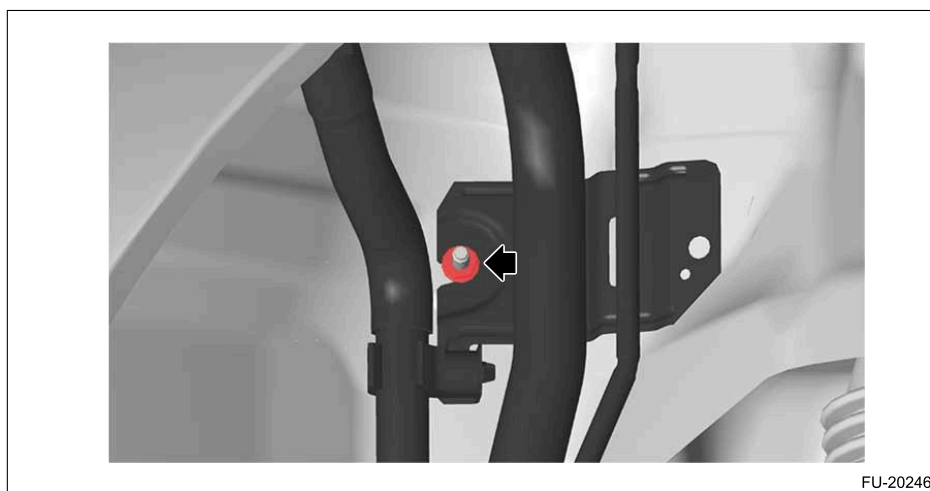


FU-20486

5. Remove the rear sub frame assembly. [Ref. to REAR SUSPENSION>Sub Frame>REMOVAL.](#)
6. Remove the mud guard rear RH. [Ref. to EXTERIOR/INTERIOR TRIM>Mud Guard>REMOVAL.](#)
7. Remove the fuel filler pipe.
 - (1) Disconnect the circulate tube (C). [Ref. to FUEL INJECTION \(FUEL SYSTEMS\)\(H4DOTC\)>Fuel Delivery and Evaporation Lines>REMOVAL > QUICK CONNECTOR DISCONNECTION \(TYPE D\).](#)
 - (2) Disconnect the drain tube (B). [Ref. to FUEL INJECTION \(FUEL SYSTEMS\)\(H4DOTC\)>Fuel Delivery and Evaporation Lines>REMOVAL > QUICK CONNECTOR DISCONNECTION \(TYPE F\).](#)
 - (3) Remove the drain tube from clip (D).
 - (4) Disconnect the fuel filler hose (A).
 - (5) Remove the bolt securing the fuel filler pipe.



8. Remove the nut securing the fuel filler pipe, and remove the fuel filler pipe from underneath of the vehicle.



FUEL INJECTION (FUEL SYSTEMS)(H4DOTC) > Fuel Filler Pipe

INSTALLATION

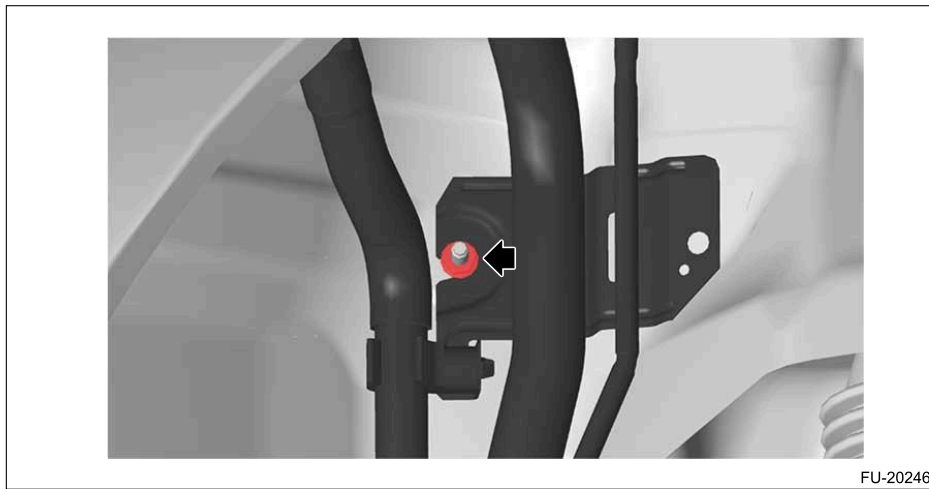
Note:

For the installation procedure of fuel filler lid, refer to "Fuel Lid".  Ref. to [SECURITY AND LOCKS>Fuel Lid>INSTALLATION](#).

1. Open the fuel filler lid.
2. Insert the fuel filler pipe into the ring clip from inside of the rear fender.
3. Install the nut securing the fuel filler pipe.

Tightening torque:

7.5 N·m (0.8 kgf-m, 5.5 ft-lb)



FU-20246

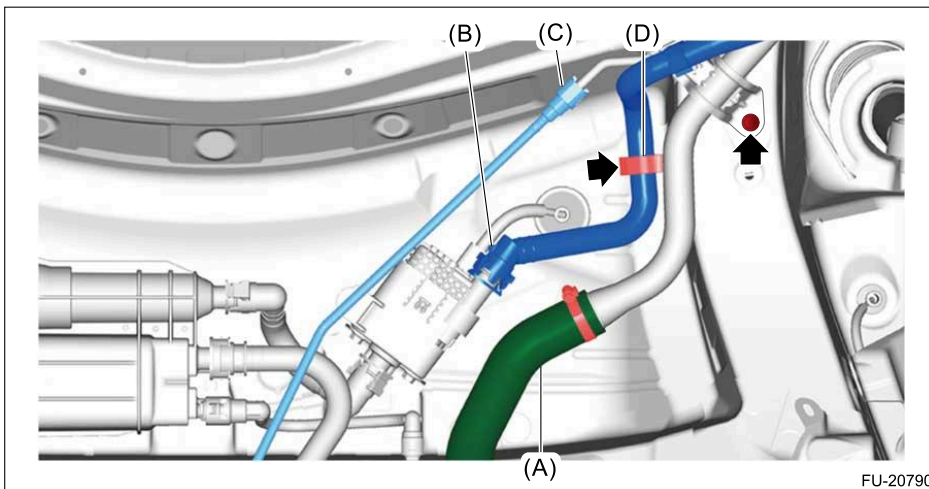
4. Install the fuel filler pipe.

- (1) Install the bolt securing the fuel filler pipe.

Tightening torque:

7.5 N·m (0.8 kgf-m, 5.5 ft-lb)

- (2) Connect the fuel filler hose (A). [Ref. to FUEL INJECTION \(FUEL SYSTEMS\)\(H4DOTC\)>Fuel Delivery and Evaporation Lines>INSTALLATION > FUEL FILLER HOSE CONNECTION.](#)
- (3) Install the drain tube to clip (D).
- (4) Connect the drain tube (B). [Ref. to FUEL INJECTION \(FUEL SYSTEMS\)\(H4DOTC\)>Fuel Delivery and Evaporation Lines>INSTALLATION > QUICK CONNECTOR CONNECTION \(TYPE F\).](#)
- (5) Connect the circulate tube (C). [Ref. to FUEL INJECTION \(FUEL SYSTEMS\)\(H4DOTC\)>Fuel Delivery and Evaporation Lines>INSTALLATION > QUICK CONNECTOR CONNECTION \(TYPE D\).](#)



FU-20790

- 5.** Install the mud guard rear RH. [Ref. to EXTERIOR/INTERIOR TRIM>Mud Guard>INSTALLATION.](#)
- 6.** Install the rear sub frame assembly. [Ref. to REAR SUSPENSION>Sub Frame>INSTALLATION.](#)
- 7.** Install the fuel filler pipe protector.
- 8.** Install the fuel filler cap, and close the fuel filler lid.

FUEL INJECTION (FUEL SYSTEMS)(H4DOTC) > Fuel Filler Pipe

DISASSEMBLY

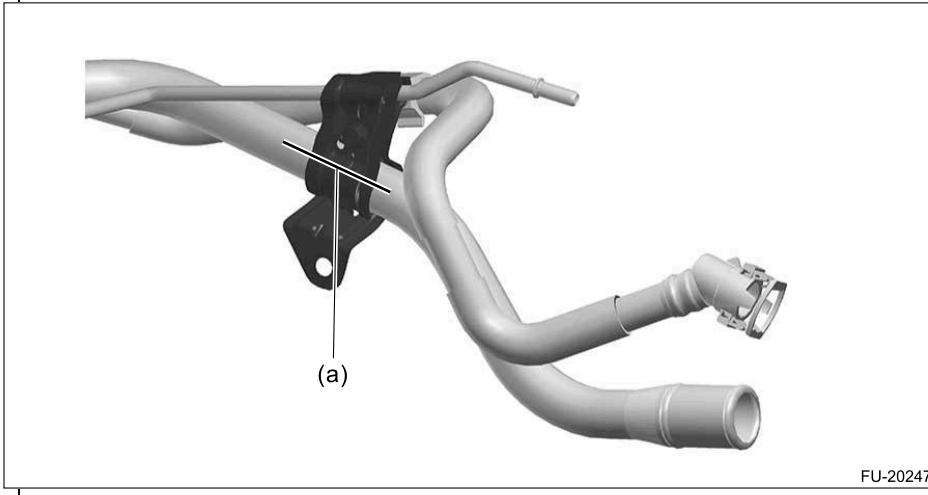


- 1.** Remove the drain filter. [Ref. to EMISSION CONTROL \(AUX. EMISSION CONTROL DEVICES\)\(H4DOTC\)>Drain Filter>REMOVAL.](#)

2. Disassemble the fuel filler pipe. [Ref. to FUEL INJECTION \(FUEL SYSTEMS\)\(H4DOTC\)>General Description>COMPONENT > FUEL FILLER PIPE.](#)

Note:

Using a marker pen, make alignment marks (a) to use for positioning brackets during assembly.



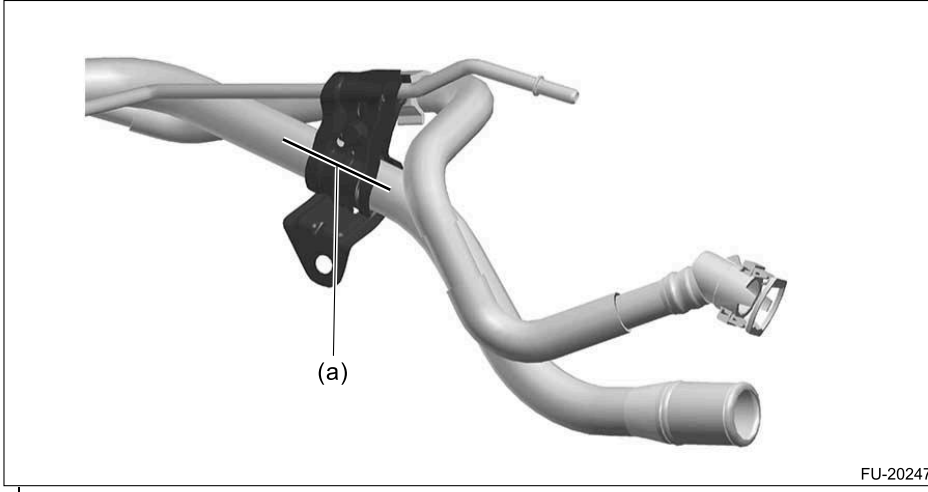
FUEL INJECTION (FUEL SYSTEMS)(H4DOTC) > Fuel Filler Pipe

ASSEMBLY

1. Using a new neck holder, assemble the fuel filler pipe. [Ref. to FUEL INJECTION \(FUEL SYSTEMS\)\(H4DOTC\)>General Description>COMPONENT > FUEL FILLER PIPE.](#)

Note:

Install the fuel filler pipe bracket to the fuel filler pipe by aligning the alignment marks (a).



2. Install the drain filter. [Ref. to EMISSION CONTROL \(AUX. EMISSION CONTROL DEVICES\)\(H4DOTC\)>Drain Filter>INSTALLATION.](#)

FUEL INJECTION (FUEL SYSTEMS)(H4DOTC) > Fuel Filler Pipe

INSPECTION

1. Check that the fuel filler pipe has no deformation, cracks or other damages.
2. Check that the fuel hose has no cracks, damage or loose part.

REMOVAL



Warning:





Place "NO OPEN FLAMES" signs near the working area.

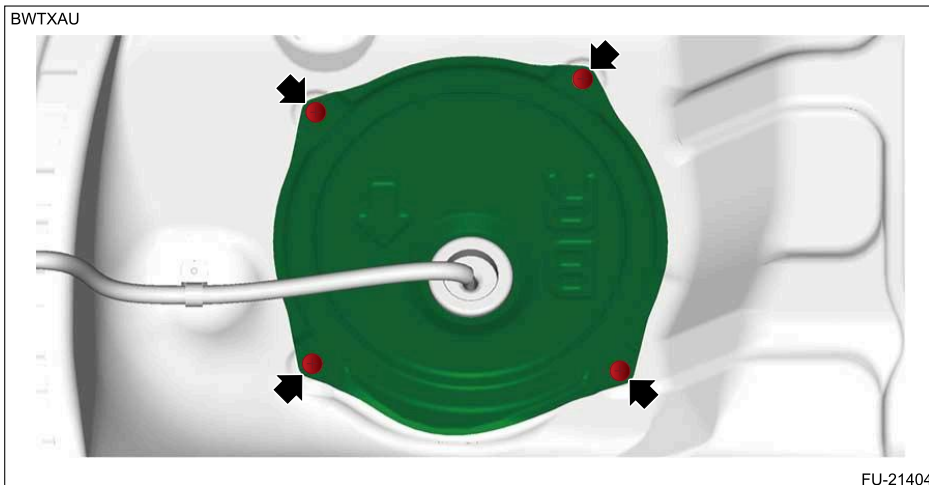
Caution:

- Be careful not to spill fuel.
- Catch the fuel from the tubes using a container or cloth.
- If the fuel gauge indicates that two thirds or more of the fuel is remaining, be sure to drain fuel before starting work to avoid the fuel to spill.

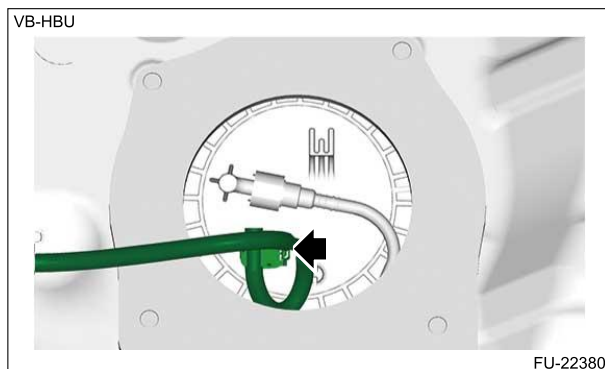
Note:

- Fuel pump assembly consists of fuel pump, fuel filter and fuel level sensor.
- For the removal procedure of fuel pump, refer to "Fuel Filter".  [Ref. to FUEL INJECTION \(FUEL SYSTEMS\) \(H4DOTC\)>Fuel Filter>REMOVAL.](#)

1. Release the fuel pressure.  [Ref. to FUEL INJECTION \(FUEL SYSTEMS\)\(H4DOTC\)>Fuel>PROCEDURE > RELEASING OF FUEL PRESSURE.](#)
2. Drain fuel.  [Ref. to FUEL INJECTION \(FUEL SYSTEMS\)\(H4DOTC\)>Fuel>PROCEDURE > DRAINING FUEL \(WITH SUBARU SELECT MONITOR\).](#)
3. Disconnect the ground terminal from battery sensor.  [Ref. to REPAIR CONTENTS>NOTE > BATTERY.](#)
4. Remove the rear seat cushion.  [Ref. to SEATS>Rear Seat>REMOVAL.](#)
5. Remove the service hole cover RH.



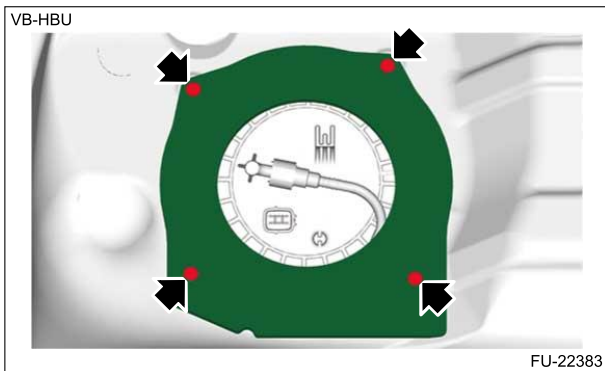
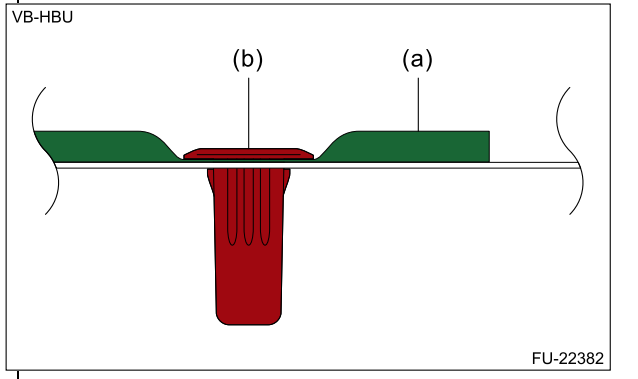
6. Disconnect the connector from fuel pump.




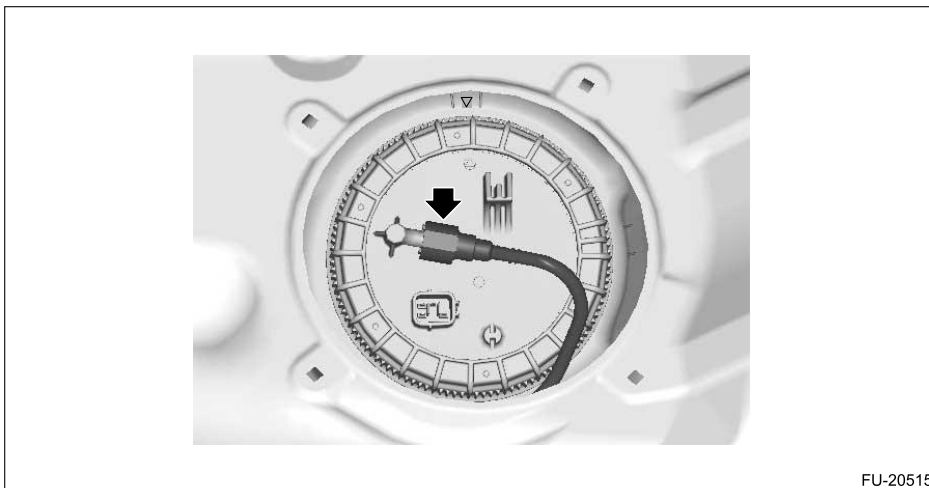
7. Remove the grommets, and remove the gasket.

Note:

The gasket (a) is secured with the grommets (b).



8. Disconnect the fuel delivery tube.  Ref. to [FUEL INJECTION \(FUEL SYSTEMS\)\(H4DOTC\)>Fuel Delivery and Evaporation Lines>REMOVAL > QUICK CONNECTOR DISCONNECTION \(TYPE D\).](#)



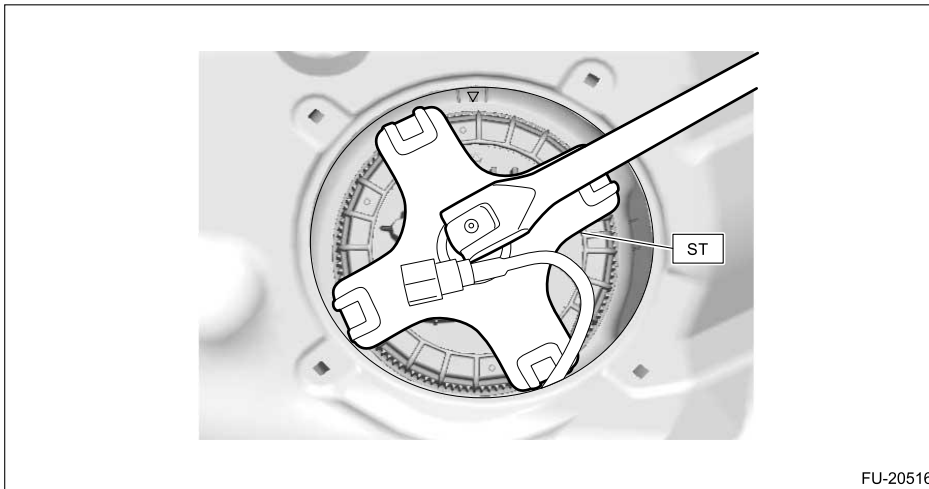
9. Remove the ring nut using the ST.


Caution:

- Be careful not to damage the fuel delivery tube with the ST.
- Before setting the ST, move the fuel delivery tube above the ST.

Preparation tool:

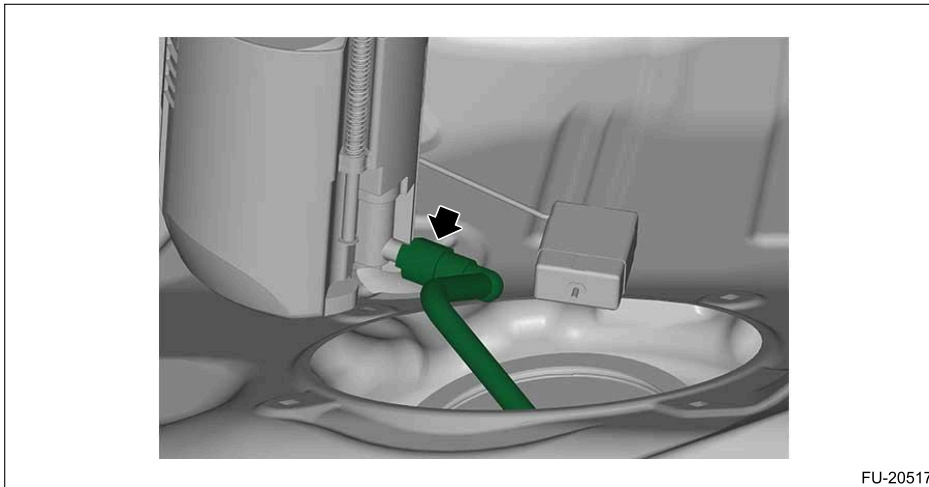
ST: ST FUEL PUMP (42099FL000)



- 10.** Take out the fuel pump assembly from the fuel tank, and disconnect the fuel sub delivery tube from the fuel pump assembly.
 Ref. to [FUEL INJECTION \(FUEL SYSTEMS\)\(H4DOTC\)>Fuel Delivery and Evaporation Lines>REMOVAL > QUICK CONNECTOR DISCONNECTION \(TYPE D\)](#).

Caution:

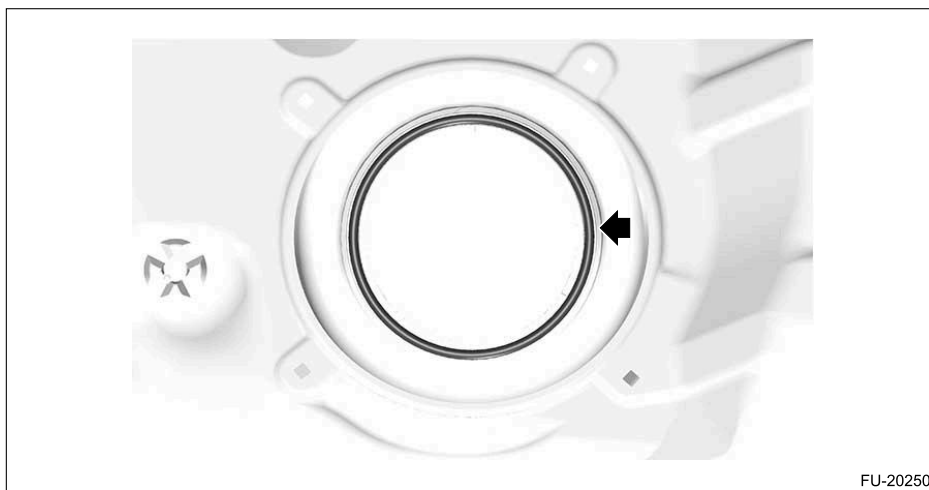
Be careful not to let the arm and float of the fuel level sensor contact the fuel tank.



FUEL INJECTION (FUEL SYSTEMS)(H4DOTC) > Fuel Pump Assembly

INSTALLATION

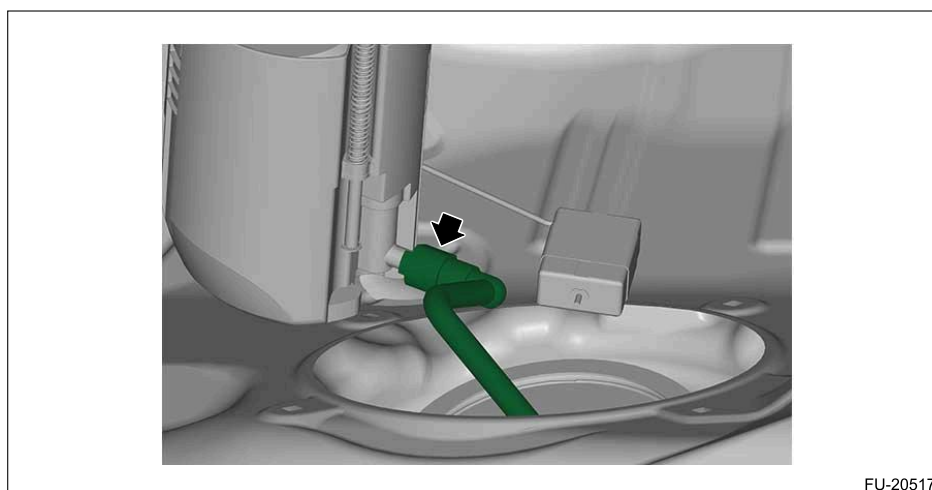
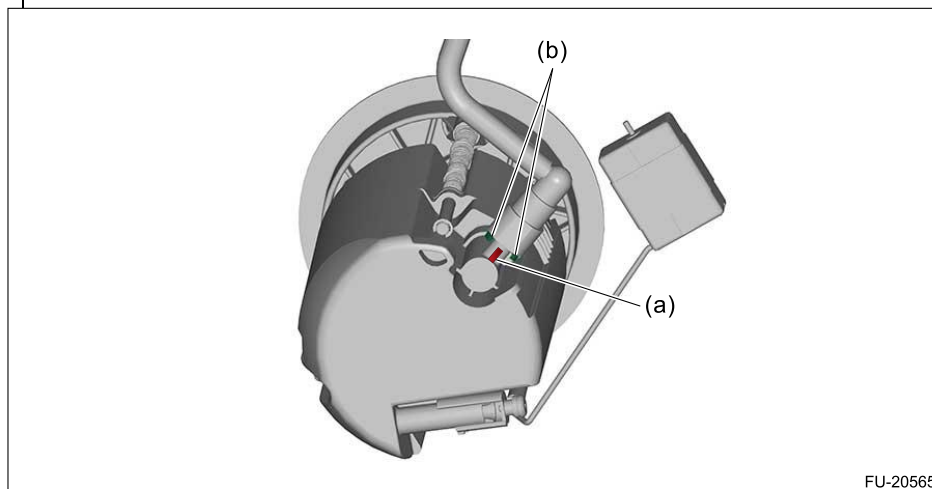
- 1.** Install a new gasket to the fuel tank.



2. Connect the fuel sub delivery tube to the fuel pump assembly.  Ref. to [FUEL INJECTION \(FUEL SYSTEMS\)\(H4DOTC\)>Fuel Delivery and Evaporation Lines>INSTALLATION > QUICK CONNECTOR CONNECTION \(TYPE D\)](#).

Note:

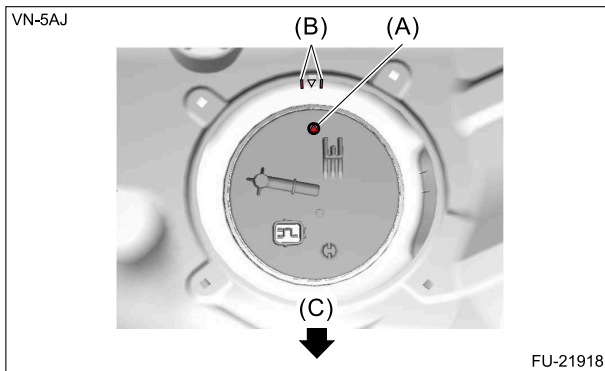
Connect so that the rib (a) of fuel pump assembly aligns between the retainers (b) of quick connector.



3. Set the fuel pump to the position shown in the figure.

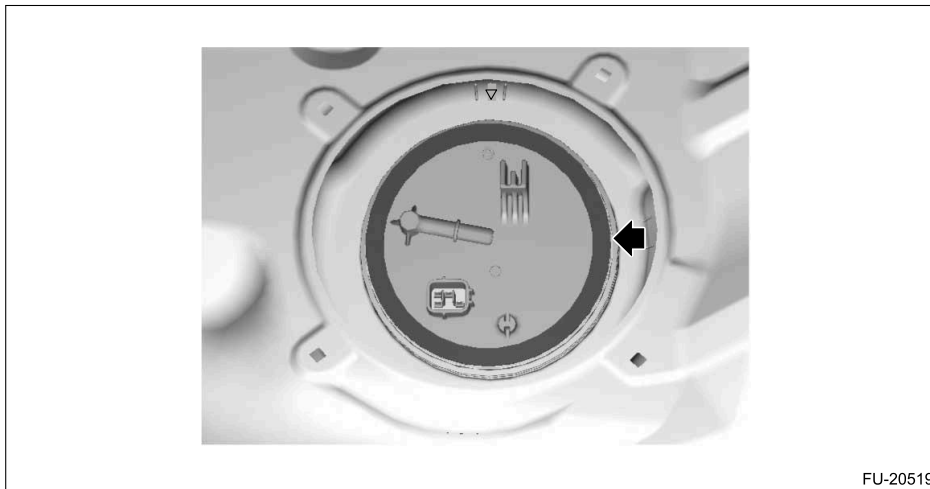
Caution:

- Be careful not to spill any fuel over the gasket. If any fuel is spilled onto the gasket, wipe it off completely. Otherwise the fuel pump may rotate together with the ring nut.
- Set the arm and float of the fuel level sensor while paying attention to prevent them from contacting the fuel tank. If the arm of the fuel level sensor is bent, the fuel gauge may not read correctly.



(A) Position mark (fuel pump) (B) Fuel pump installation position (C) Front side of vehicle range mark (fuel tank)

4. Set a new ring nut plate.

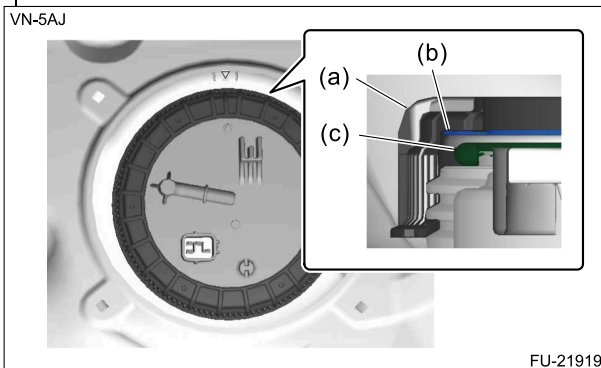


FU-20519

5. Set a new ring nut, and align the fuel tank installation start position mark (A) with the ring nut position mark (B).

Note:

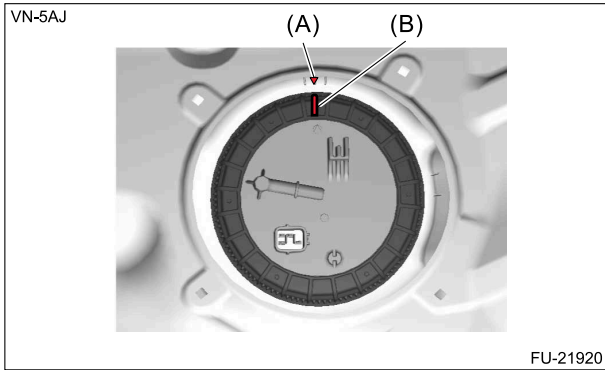
- Make sure that the ring nut, ring nut plate and gasket are set as shown in the figure.



FU-21919

(a) Ring nut (b) Ring nut plate (c) Gasket

- Set the ring nut by firmly pressing against the fuel tank.



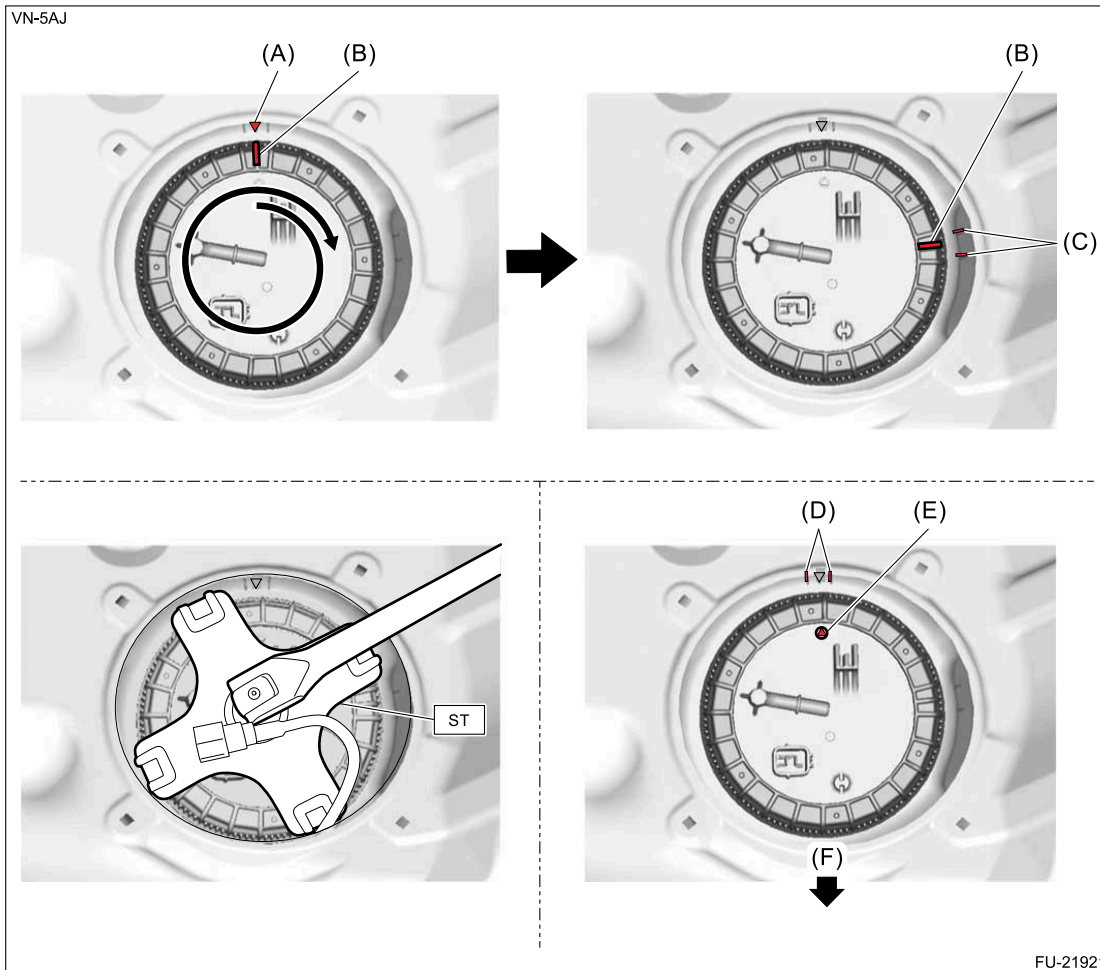
6. Using the ST, tighten the ring nut by one turn, and then tighten until the ring nut position mark is located within the installation end position range mark on the fuel tank.

Caution:

- Be careful not to damage the fuel delivery tube with the ST.
- Before setting the ST, move the fuel delivery tube above the ST.
- Make sure that the ring nut position mark is located within the installation position end range mark on the fuel tank as shown in the figure.
- Make sure that the position mark on the fuel pump is located within the installation position range mark on the fuel tank as shown in the figure.

Preparation tool:

ST: ST FUEL PUMP (42099FL000)



(A) Ring nut installation position start mark (fuel tank)

(C) Ring nut installation position end range mark (fuel tank)

(E) Position mark (fuel pump)

- (B) Position mark (ring nut) (D) Fuel pump installation position (F) Front side of vehicle range mark (fuel tank)

7. Using a caliper with depth gauge, measure the dimension (3 positions) of the ring nut and the top of fuel tank to check the tightening condition of the ring nut.

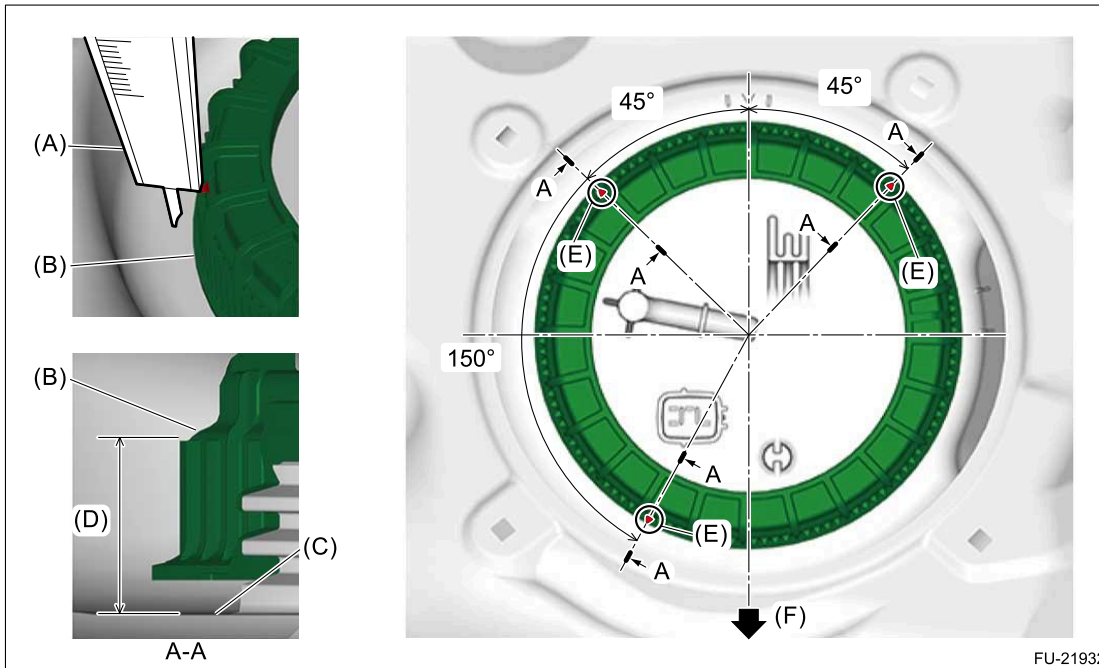
Caution:

- If the measured value exceeds the standard, retighten the ring nut to correct erroneous tightening of the ring nut.
- If the ring nut and ring nut plate are deformed, cracked or damaged, replace them with new parts.

Dimension of ring nut and top of fuel tank:

Standard

21.3 – 26.3 mm (0.839 – 1.035 in)



- (A) Caliper with depth gauge (C) Fuel tank (E) Measuring point
 (B) Ring nut (D) Dimension of ring nut and top of fuel tank (F) Front side of vehicle

8. Connect the fuel delivery tube. [Ref. to FUEL INJECTION \(FUEL SYSTEMS\)\(H4DOTC\)>Fuel Delivery and Evaporation Lines>INSTALLATION > QUICK CONNECTOR CONNECTION \(TYPE D\).](#)



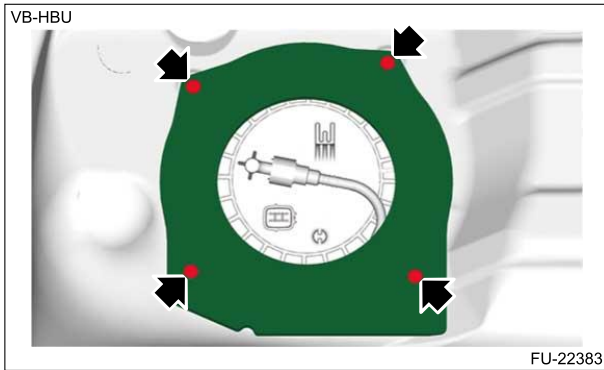
9. Set the gasket and install the grommets.

Caution:

- If the gasket is damaged, replace it with a new part.
- Make sure that the gasket is installed in the correct orientation.
- Make sure that the grommets are fully inserted.

Note:

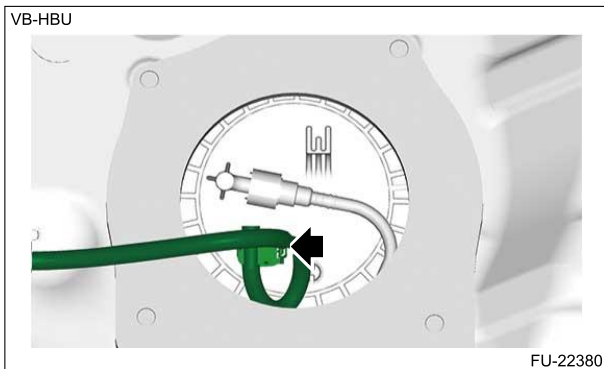
If the threaded portion of grommet is faulty, replace the grommet with a new part.



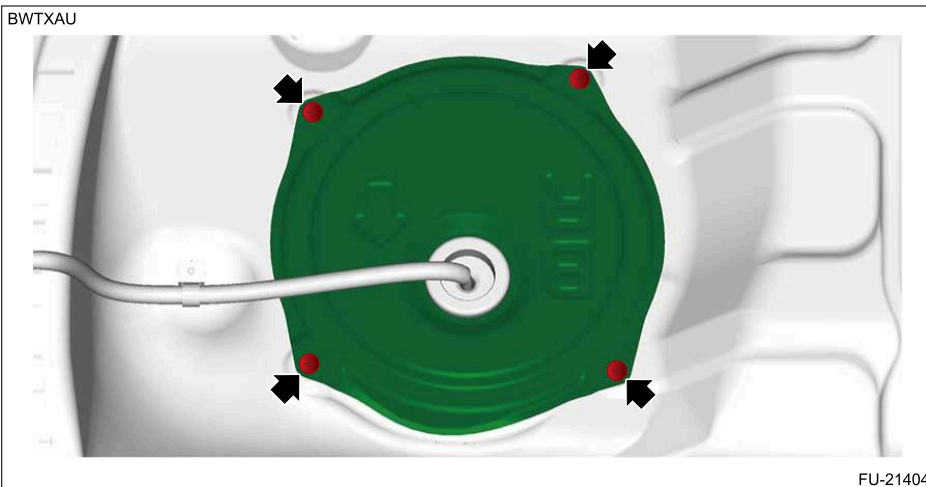
10. Connect the connector to the fuel pump.

Caution:

Before connecting, make sure that there are no foreign matters, water, etc. inside the connectors of fuel pump and harness. If any foreign matters, water, etc. are found, remove them with air blow and connect the connector after it has dried completely.



11. Install the service hole cover RH.



12. Install the rear seat cushion.  [Ref. to SEATS>Rear Seat>INSTALLATION.](#)

13. Connect the ground terminal to battery sensor.  [Ref. to REPAIR CONTENTS>NOTE > BATTERY.](#)

INSPECTION

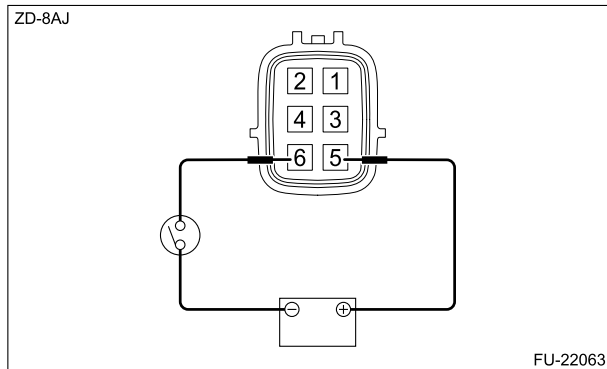
1. Check that the fuel pump has no deformation, cracks or other damages.
2. Connect the battery positive terminal to terminal No. 5 and the battery negative terminal to terminal No. 6, and inspect the fuel pump operation.

Warning:

- Wipe off fuel completely.
- Keep the battery as far apart from fuel pump as possible.
- Do not run the fuel pump for a long time under non-load condition.

Caution:

- When applying battery voltage between the terminals, use test leads suitable for the terminals.
- Be sure to use switches to apply battery voltage. Otherwise, terminal damage may occur.



FUEL INJECTION (FUEL SYSTEMS)(H4DOTC) > Fuel Level Sensor

REMOVAL

Warning:

Place "NO OPEN FLAMES" signs near the working area.

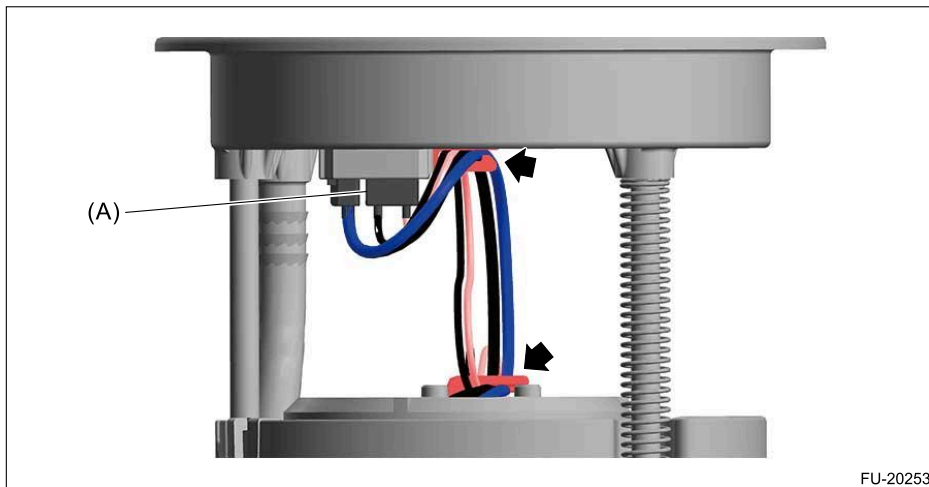
Caution:

- Be careful not to spill fuel.
- If the fuel gauge indicates that two thirds or more of the fuel is remaining, be sure to drain fuel before starting work to avoid the fuel to spill.

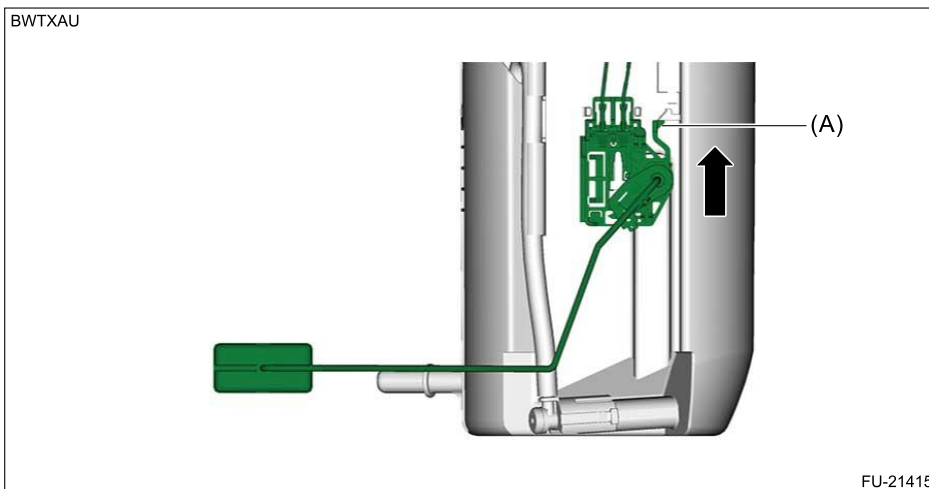
Note:

The fuel level sensor is built in fuel pump assembly.

1. Remove the fuel pump assembly. [Ref. to FUEL INJECTION \(FUEL SYSTEMS\)\(H4DOTC\)>Fuel Pump Assembly>REMOVAL.](#)
2. Disconnect the fuel level sensor connector (A), and pull out the connector cable and fuel level sensor harness from the clip.



3. While pressing the claw (A) of the fuel level sensor, slide the fuel level sensor in the direction of the arrow, and remove the fuel level sensor.



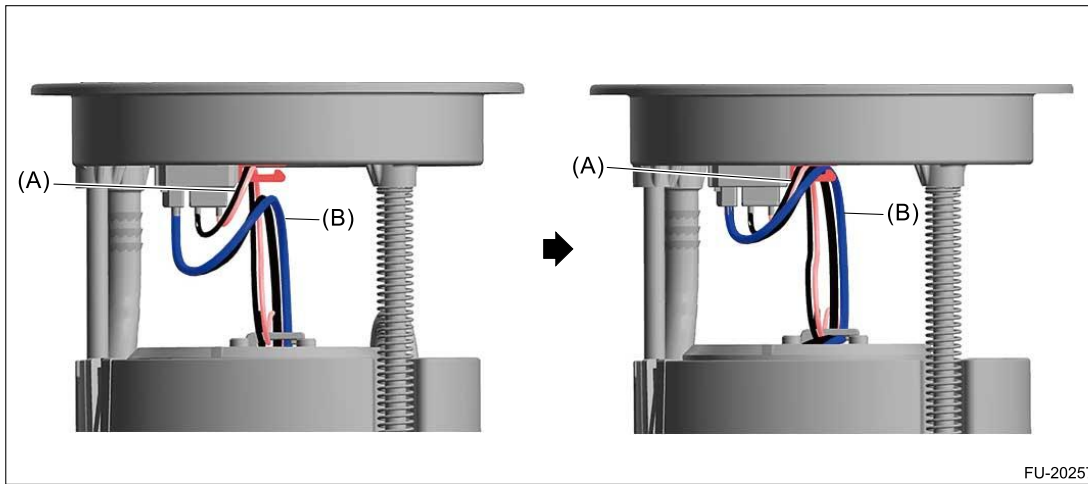
FUEL INJECTION (FUEL SYSTEMS)(H4DOTC) > Fuel Level Sensor

INSTALLATION

1. Install the fuel level sensor to the fuel pump assembly.

Caution:

Be sure to install the fuel level sensor harness to the clip first, then install the connector cable. Otherwise, malfunction may occur.



(A) Fuel level sensor harness (B) Connector cable

2. Install the fuel pump assembly.  [Ref. to FUEL INJECTION \(FUEL SYSTEMS\)\(H4DOTC\)>Fuel Pump Assembly>INSTALLATION.](#)

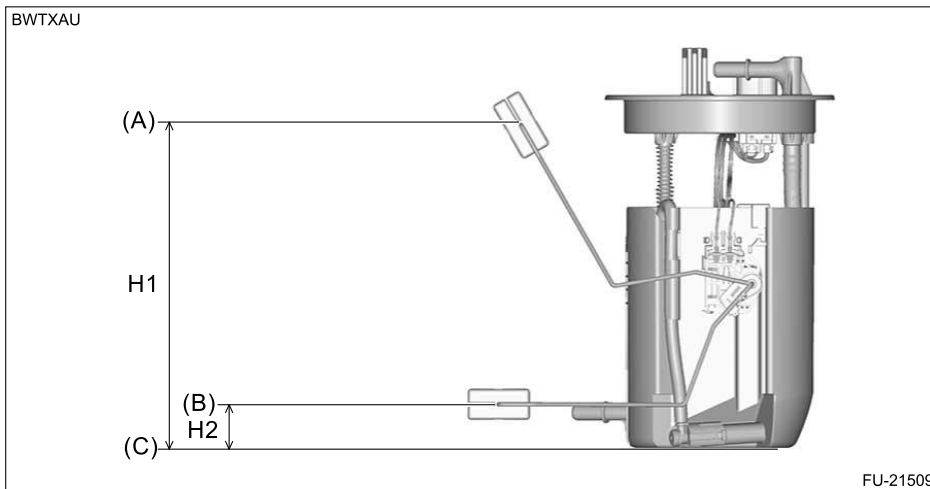
FUEL INJECTION (FUEL SYSTEMS)(H4DOTC) > Fuel Level Sensor

INSPECTION

1. Check that the fuel level sensor has no damage.
2. Measure the fuel level sensor float position.

Note:

When inspecting the fuel level sensor, perform the work with the sensor installed to the fuel pump.

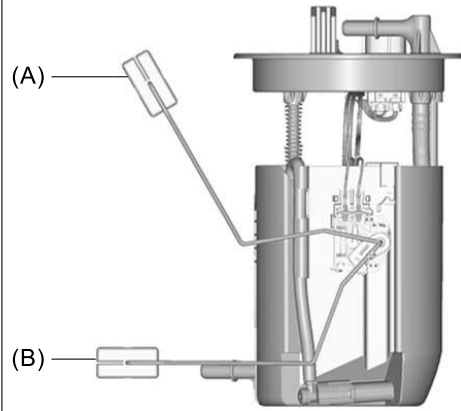
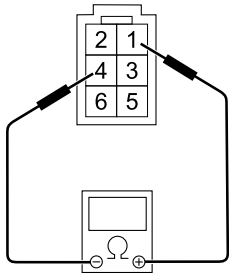


(A) FULL (B) EMPTY (C) Fuel tank seating surface

Float position	Standard
FULL — Fuel tank seating surface H1	187.2 — 194.2 mm (7.37 — 7.646 in)
EMPTY — Fuel tank seating surface H2	21.1 — 28.1 mm (0.831 — 1.107 in)

3. Check the resistance between fuel level sensor terminals by the connector on top of the fuel pump.

VB-HEU



FU-23546

Float position	Terminal No.	Standard
FULL (A)	1 - 4	7.7 - 9.7 Ω
EMPTY (B)		230.9 - 235.9 Ω

REMOVAL



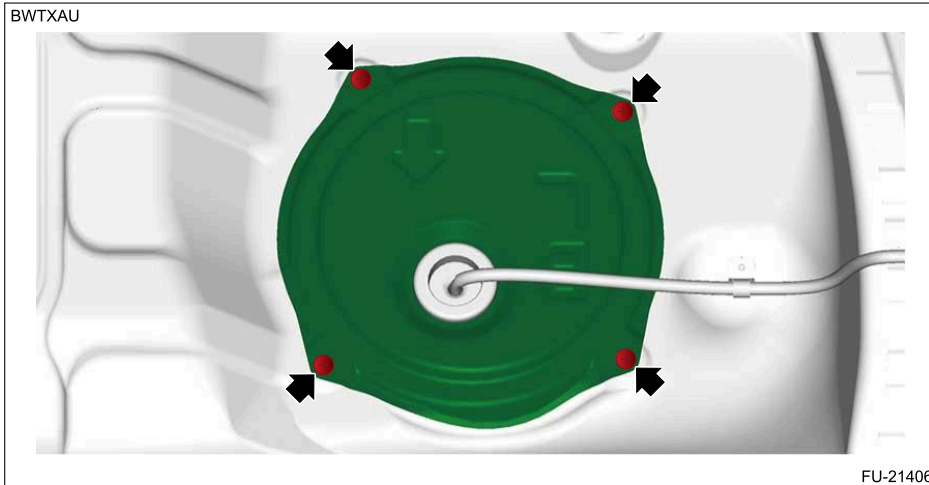
Warning:

Place "NO OPEN FLAMES" signs near the working area.

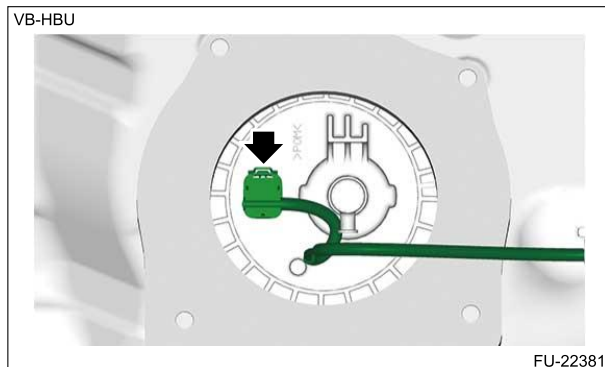
Caution:

- Be careful not to spill fuel.
- If the fuel gauge indicates that two thirds or more of the fuel is remaining, be sure to drain fuel before starting work to avoid the fuel to spill.

1. Release the fuel pressure. [Ref. to FUEL INJECTION \(FUEL SYSTEMS\)\(H4DOTC\)>Fuel>PROCEDURE > RELEASING OF FUEL PRESSURE.](#)
2. Drain fuel. [Ref. to FUEL INJECTION \(FUEL SYSTEMS\)\(H4DOTC\)>Fuel>PROCEDURE > DRAINING FUEL \(WITH SUBARU SELECT MONITOR\).](#)
3. Disconnect the ground terminal from battery sensor. [Ref. to REPAIR CONTENTS>NOTE > BATTERY.](#)
4. Remove the rear seat cushion. [Ref. to SEATS>Rear Seat>REMOVAL.](#)
5. Remove the service hole cover LH.



6. Disconnect the connector from the fuel sub level sensor.

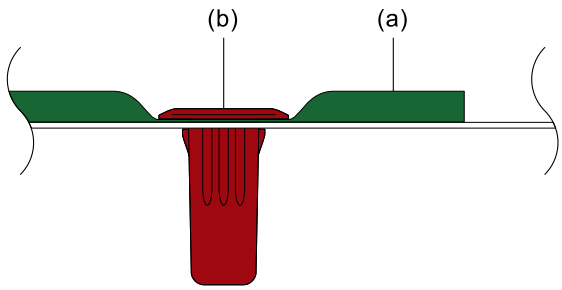


7. Remove the grommets, and remove the gasket.

Note:

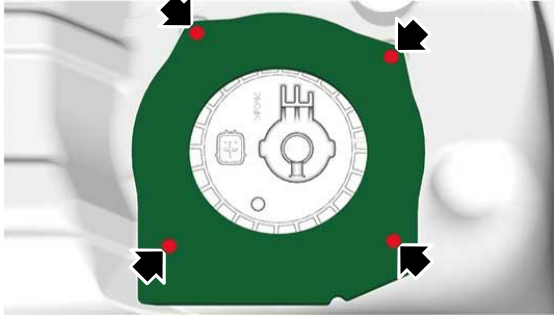
The gasket (a) is secured with the grommets (b).

VB-HBU



FU-22382

VB-HBU

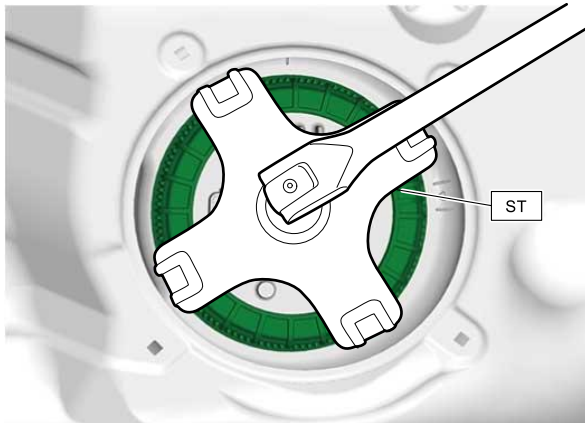


FU-22384

8. Remove the ring nut using the ST.

Preparation tool:

ST: ST FUEL PUMP (42099FL000)

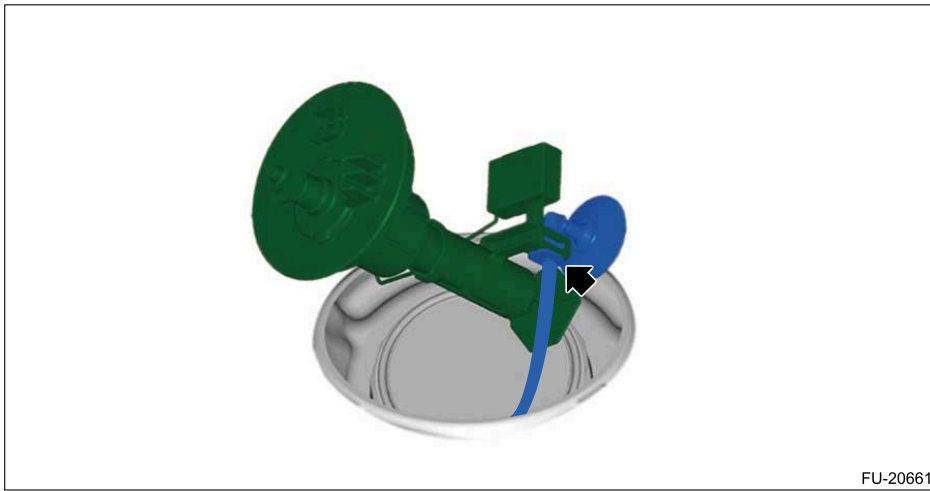


FU-20522

9. Take out the fuel sub level sensor from the fuel tank, and remove the fuel sub delivery tube from the fuel sub level sensor.

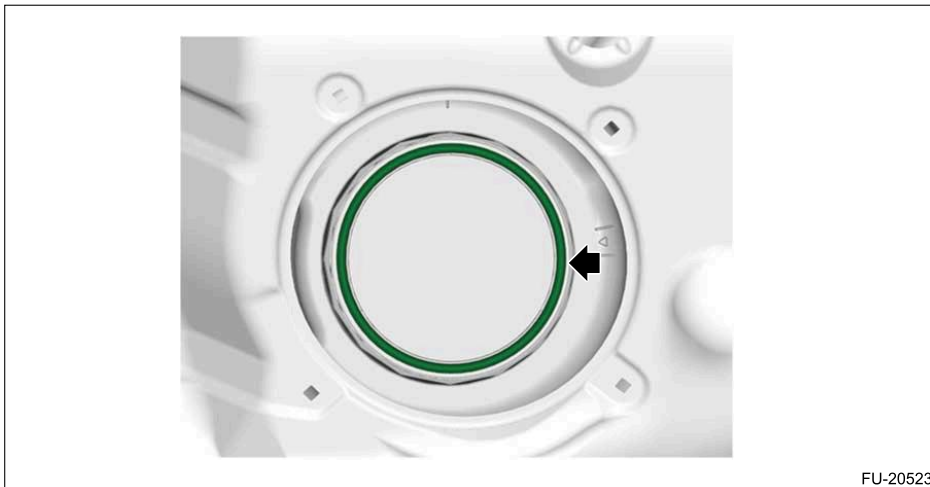
Caution:

Be careful not to let the arm and float of the fuel sub level sensor contact the fuel tank during the removal.

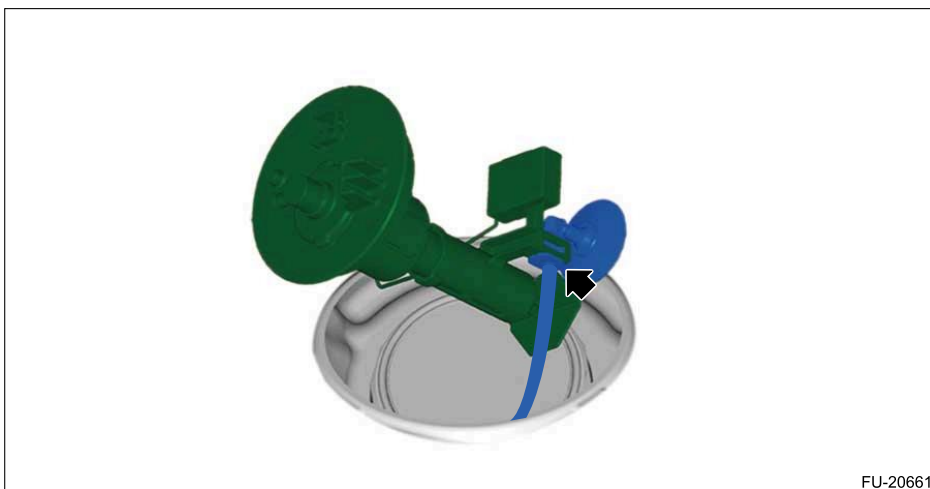


FUEL INJECTION (FUEL SYSTEMS)(H4DOTC) > Fuel Sub Level Sensor
INSTALLATION

1. Install a new gasket to the fuel tank.



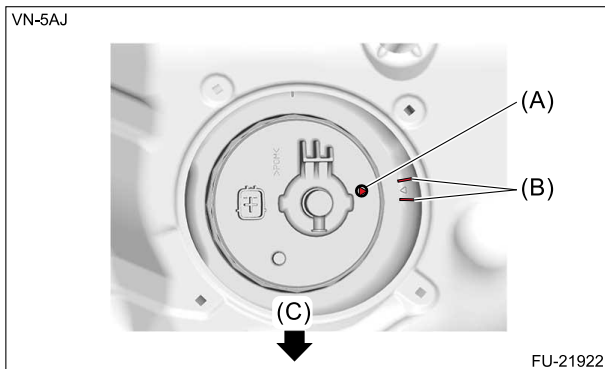
2. Install the fuel sub delivery tube to the fuel sub level sensor.



3. Set the fuel sub level sensor to the position shown in the figure.

Caution:

- Be careful not to spill any fuel over the gasket. If any fuel is spilled onto the gasket, wipe it off completely. Otherwise the fuel sub level sensor may rotate together with the ring nut.
- Set the fuel sub level sensor while paying attention to prevent its arm and float from contacting the fuel tank. If the arm of the fuel sub level sensor is bent, the fuel gauge may not read correctly.



- (A) Position mark (fuel sub level sensor) (B) Fuel sub level sensor installation position range mark (fuel tank) (C) Front side of vehicle

4. Set a new ring nut plate.

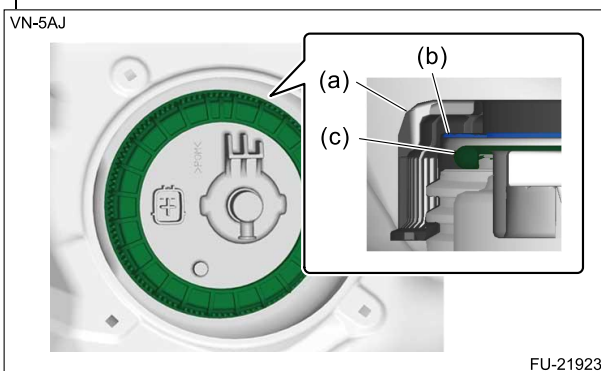


FU-20525

5. Set a new ring nut, and align the fuel tank installation start position mark (A) with the ring nut position mark (B).

Note:

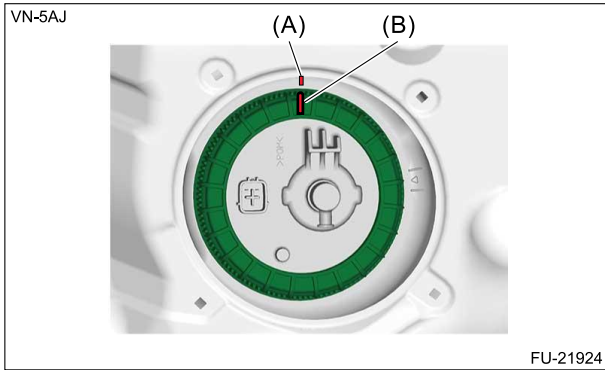
- Make sure that the ring nut, ring nut plate and gasket are set as shown in the figure.



FU-21923

- (a) Ring nut (b) Ring nut plate (c) Gasket

- Set the ring nut by firmly pressing against the fuel tank.



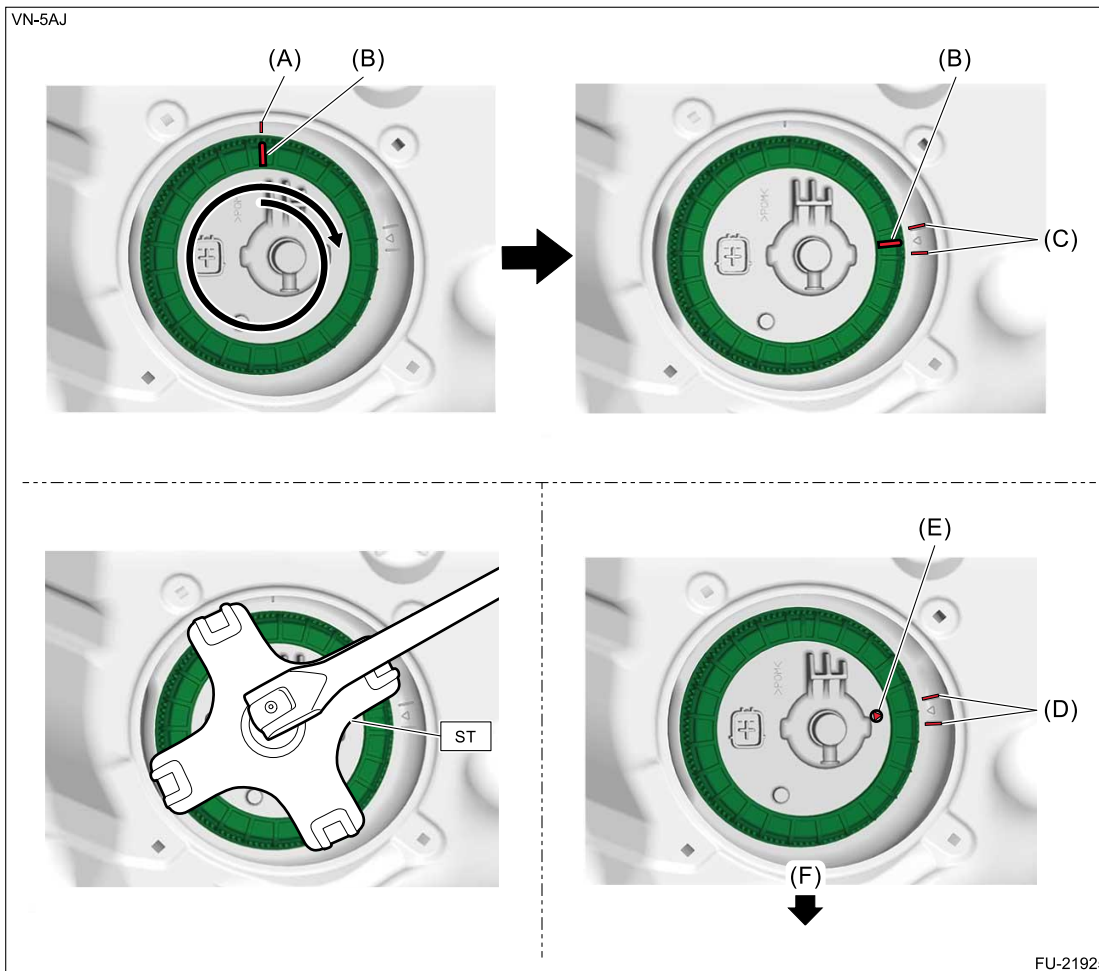
6. Using the ST, tighten the ring nut by one turn, and then tighten until the ring nut position mark is located within the installation end position range mark on the fuel tank.

Caution:

- Make sure that the ring nut position mark is located within the installation position end range mark on the fuel tank as shown in the figure.
- Make sure that the position mark on the fuel sub level sensor is located within the installation position range mark on the fuel tank as shown in the figure.

Preparation tool:

ST: ST FUEL PUMP (42099FL000)



- | | | |
|---|--|---|
| (A) Ring nut installation position start mark (fuel tank) | (C) Ring nut installation position end range mark (fuel tank) | (E) Position mark (fuel sub level sensor) |
| (B) Position mark (ring nut) | (D) Fuel sub level sensor installation position range mark (fuel tank) | (F) Front side of vehicle |

7. Using a caliper with depth gauge, measure the dimension (3 positions) of the ring nut and the top of fuel tank to check the tightening condition of the ring nut.

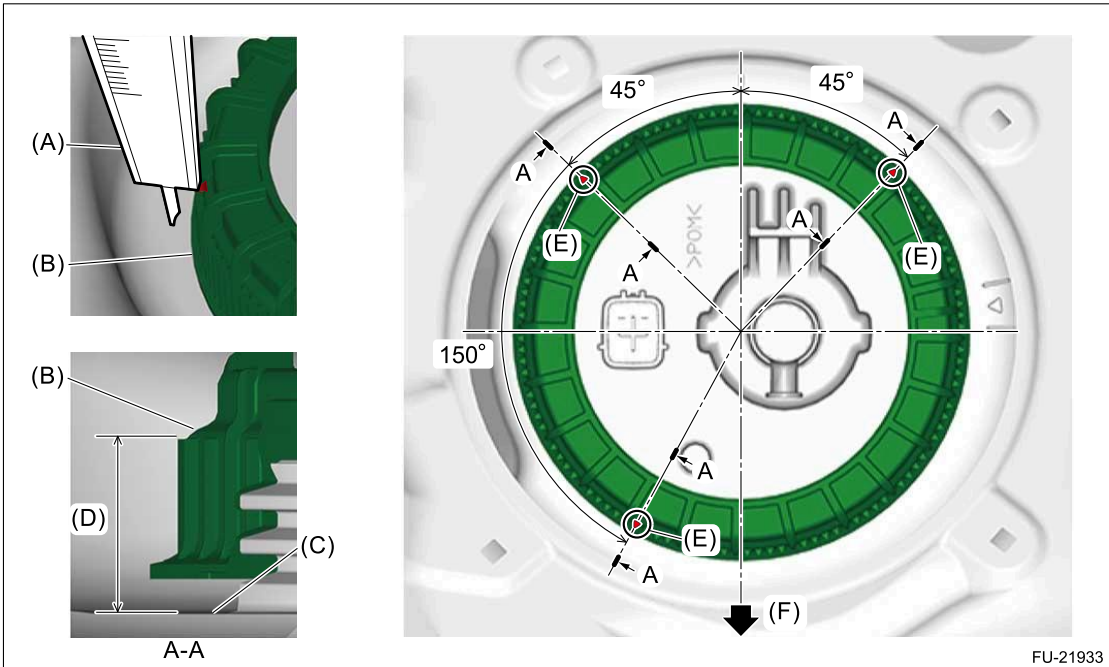
Caution:

- If the measured value exceeds the standard, retighten the ring nut to correct erroneous tightening of the ring nut.
- If the ring nut and ring nut plate are deformed, cracked or damaged, replace them with new parts.

Dimension of ring nut and top of fuel tank:

Standard

21.3 – 26.3 mm (0.839 – 1.035 in)



- | | | |
|------------------------------|-----------------------------------|--|
| (A) Caliper with depth gauge | (C) Fuel tank | (E) Measuring point |
| (B) Ring nut | (D) Dimension of ring nut and top | (F) Front side of vehicle of fuel tank |

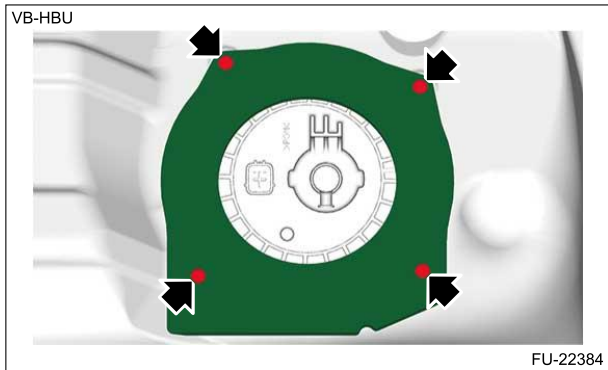
8. Set the gasket and install the grommets.

Caution:

- If the gasket is damaged, replace it with a new part.
- Make sure that the gasket is installed in the correct orientation.
- Make sure that the grommets are fully inserted.

Note:

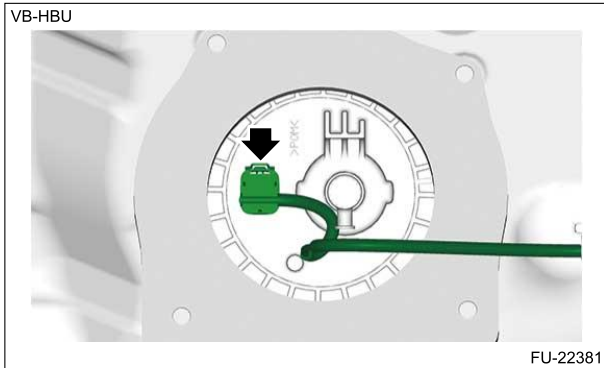
If the threaded portion of grommet is faulty, replace the grommet with a new part.



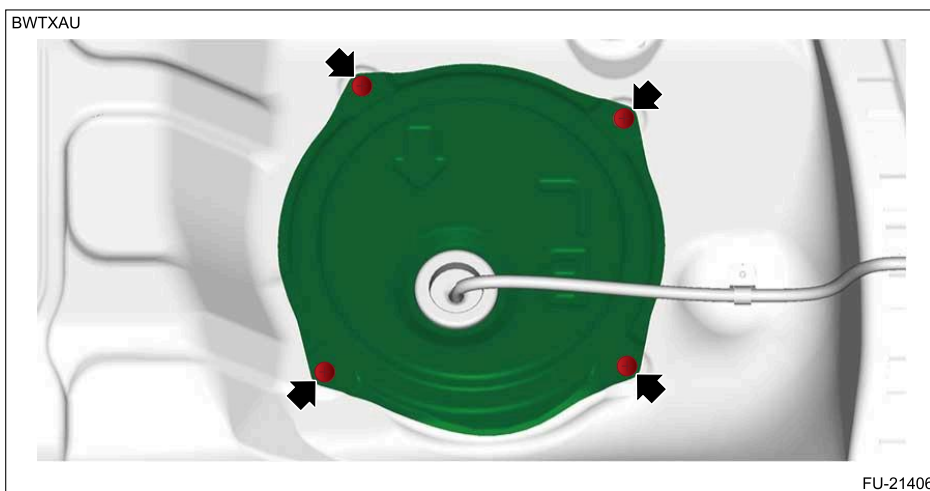
9. Connect the connector to the fuel sub level sensor.

Caution:

Before connecting, make sure that there are no foreign matters, water, etc. inside the connectors of fuel sub level sensor and harness. If any foreign matters, water, etc. are found, remove them with air blow and connect the connector after it has dried completely.



10. Install the service hole cover LH.



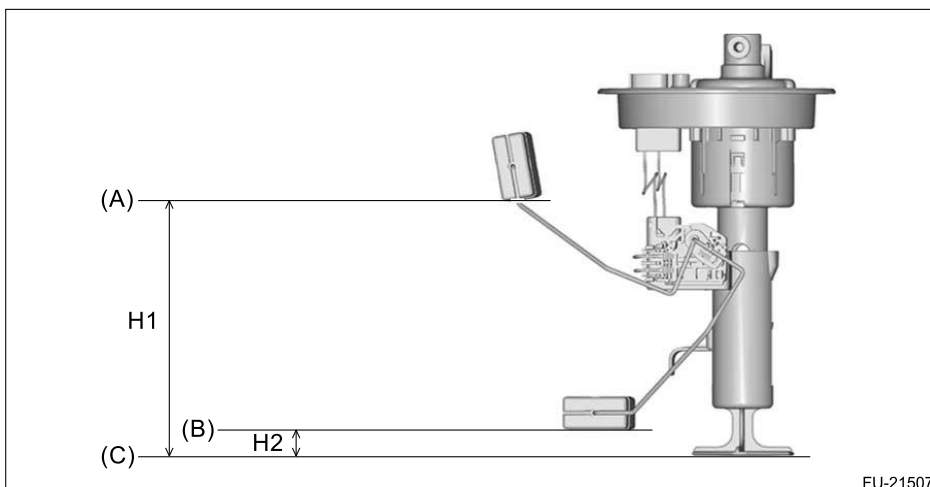
11. Install the rear seat cushion. [Ref. to SEATS>Rear Seat>INSTALLATION.](#)

12. Connect the ground terminal to battery sensor. [Ref. to REPAIR CONTENTS>NOTE > BATTERY.](#)

FUEL INJECTION (FUEL SYSTEMS)(H4DOTC) > Fuel Sub Level Sensor

INSPECTION

1. Check that the fuel sub level sensor has no damage.
2. Check the fuel sub level sensor float position.



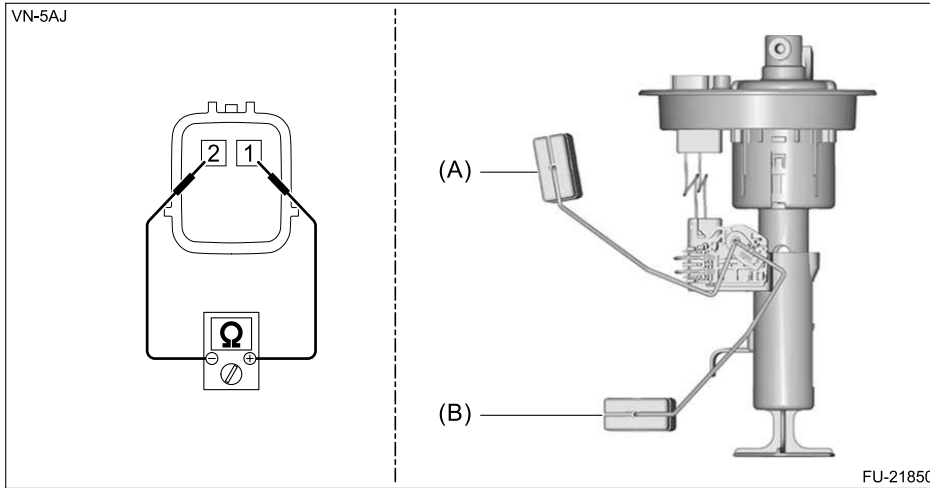
(A) FULL

(B) EMPTY

(C) Fuel sub level sensor seating surface

Float position	Standard
FULL — Fuel sub level sensor seating surface H1	140.6 — 149.6 mm (5.536 — 5.89 in)
EMPTY — Fuel sub level sensor seating surface H2	10.1 — 19.1 mm (0.398 — 0.752 in)

3. Check the resistance between fuel sub level sensor terminals by the connector on top of the fuel sub level sensor.



Float position	Terminal No.	Standard
FULL (A)	1 — 2	7.7 — 9.7 Ω
EMPTY (B)		174.6 — 178.6 Ω

REMOVAL



Warning:



Place "NO OPEN FLAMES" signs near the working area.

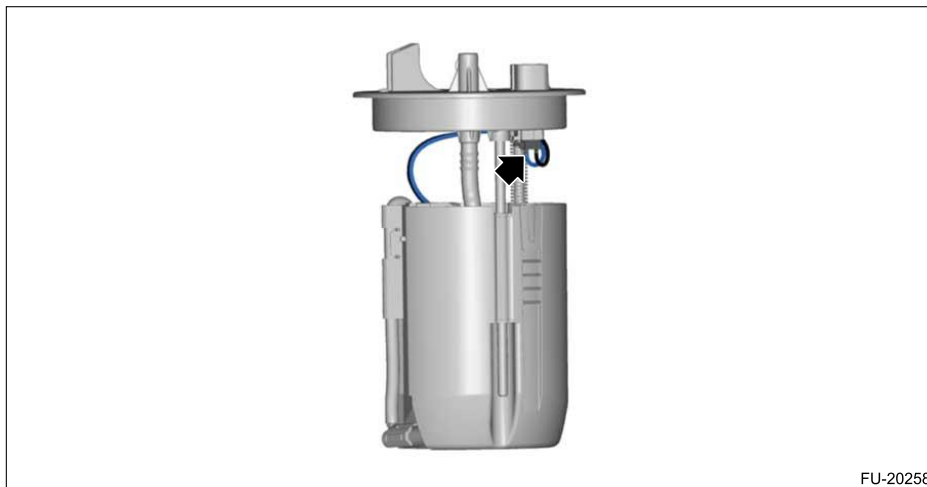
Caution:

- Be careful not to spill fuel.
- If the fuel gauge indicates that two thirds or more of the fuel is remaining, be sure to drain fuel before starting work to avoid the fuel to spill.
- Be careful not to drop or apply any impact to the fuel pump during work. This may deteriorate its performance.

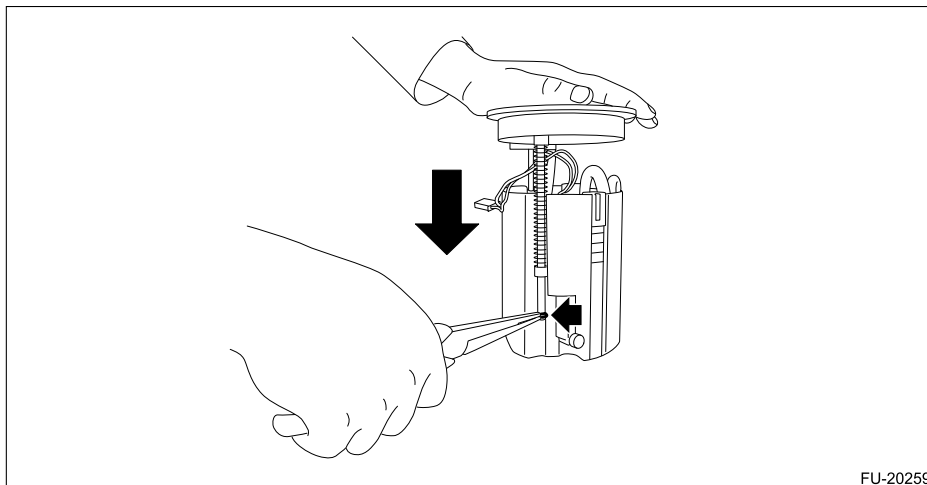
Note:

The fuel filter is built in fuel pump assembly.

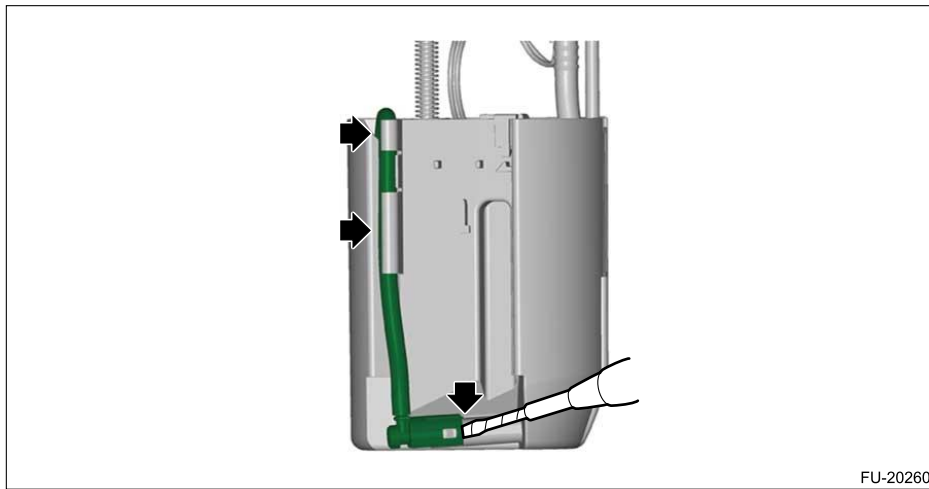
1. Remove the fuel pump assembly.  [Ref. to FUEL INJECTION \(FUEL SYSTEMS\)\(H4DOTC\)>Fuel Pump Assembly>REMOVAL.](#)
2. Remove the fuel level sensor.  [Ref. to FUEL INJECTION \(FUEL SYSTEMS\)\(H4DOTC\)>Fuel Level Sensor>REMOVAL.](#)
3. Disconnect the connector cable.



4. Push the fuel filter assembly in the direction of the arrow to compress, and detach the connecting clip.



5. Release the claw using a flat tip screwdriver or similar tool wrapped with a protection tape, and remove the tube assembly from the fuel chamber assembly.



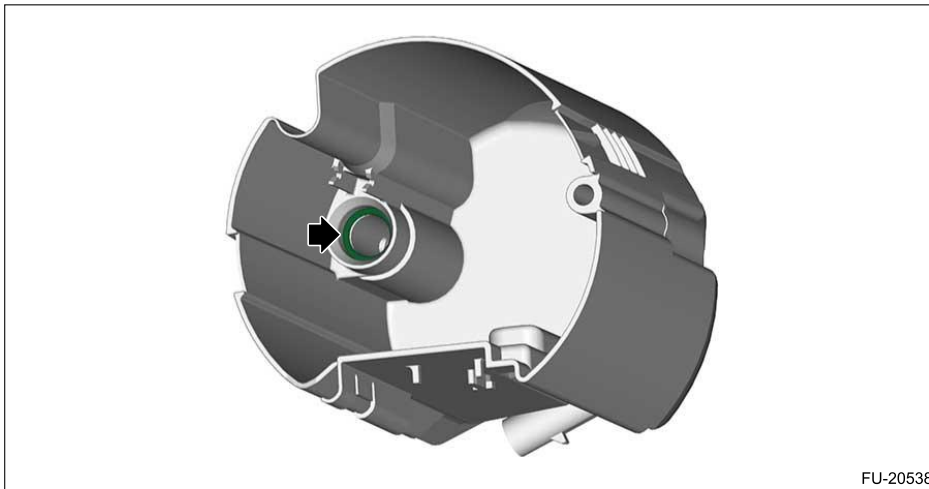
6. Disengage three claws on the fuel pump holder from the fuel chamber assembly, and remove the fuel filter assembly.



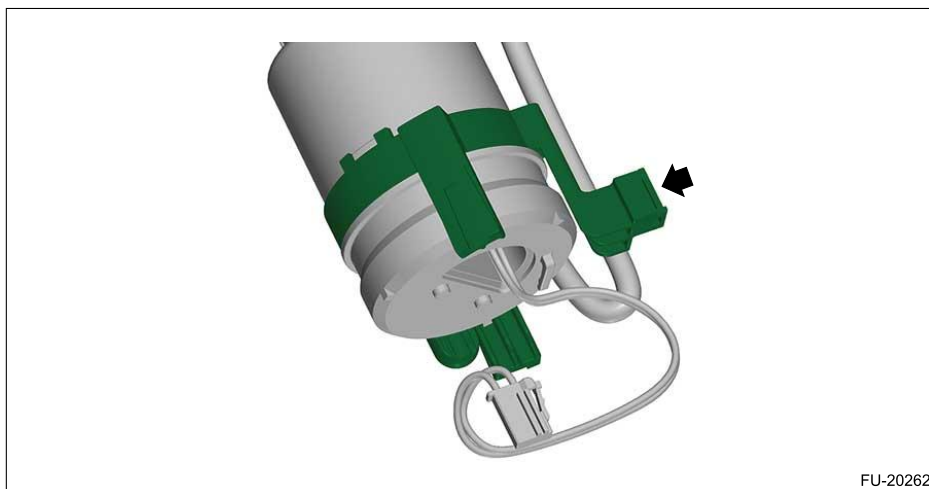
7. Remove the tube assembly from the fuel chamber assembly.



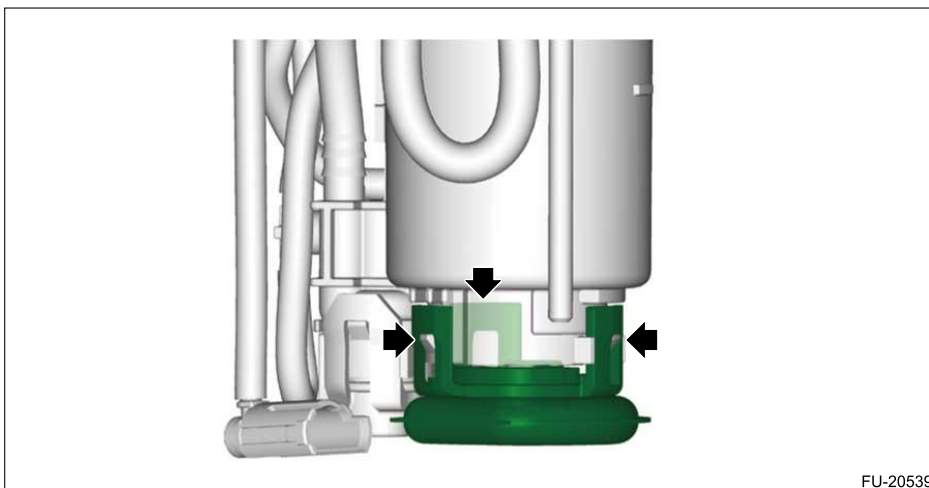
8. Remove the O-ring from the fuel chamber assembly.



9. Remove the fuel pump holder.



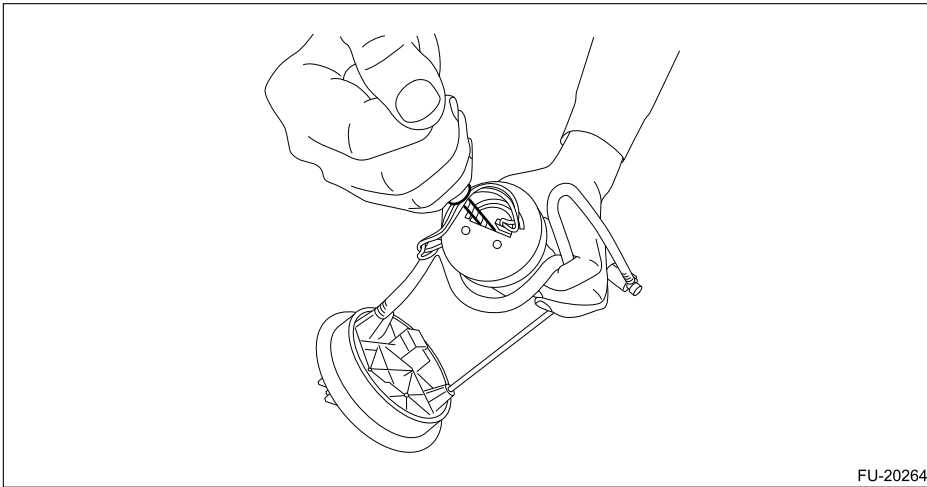
10. Disengage three claws on the fuel pump.



11. Using a flat tip screwdriver or similar tool wrapped with a protection tape, press on the fuel pump and remove the fuel pump from the fuel filter assembly.

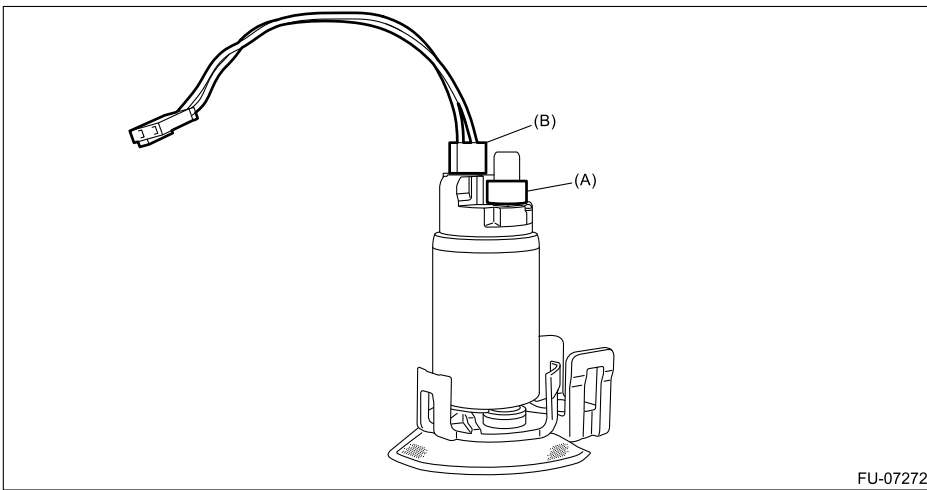
Caution:

If O-rings remain on the fuel filter assembly side, they must be carefully removed using a precision screwdriver or similar tool wrapped with a protection tape.



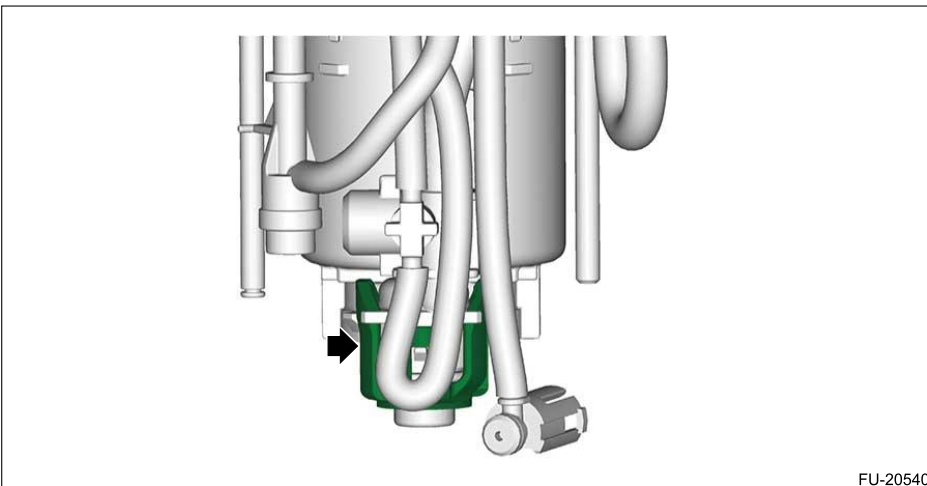
FU-20264

12. Remove the spacer (A) and connector cable (B) from the fuel pump.



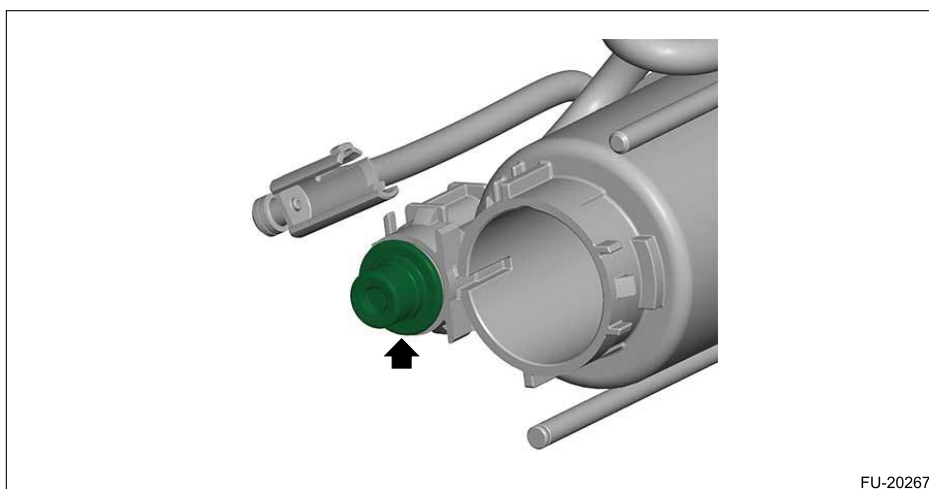
FU-07272

13. Remove the pressure regulator cap.



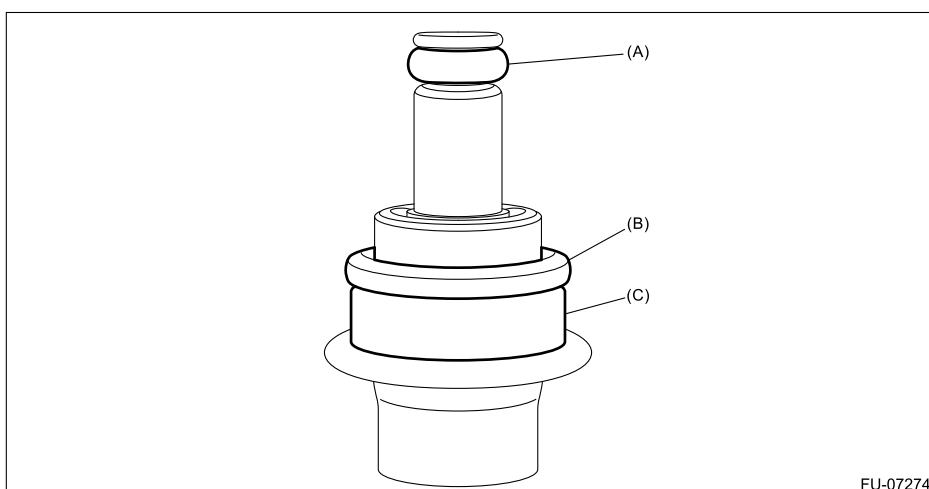
FU-20540

14. Remove the pressure regulator from the fuel filter assembly.



FU-20267

15. Remove O-ring (A), O-ring (B), and backup ring (C) from the pressure regulator.



FU-07274

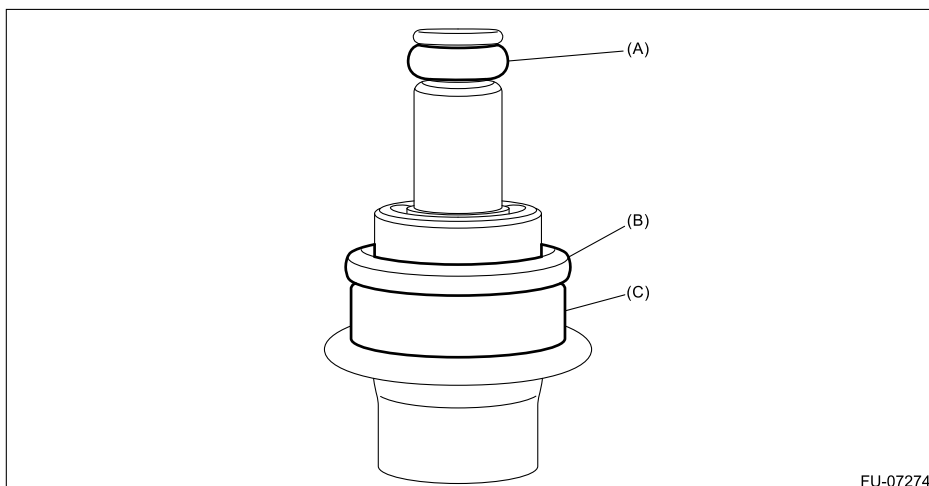
FUEL INJECTION (FUEL SYSTEMS)(H4DOTC) > Fuel Filter

INSTALLATION

1. Install backup ring (C), new O-ring (B) and new O-ring (A) to the pressure regulator.

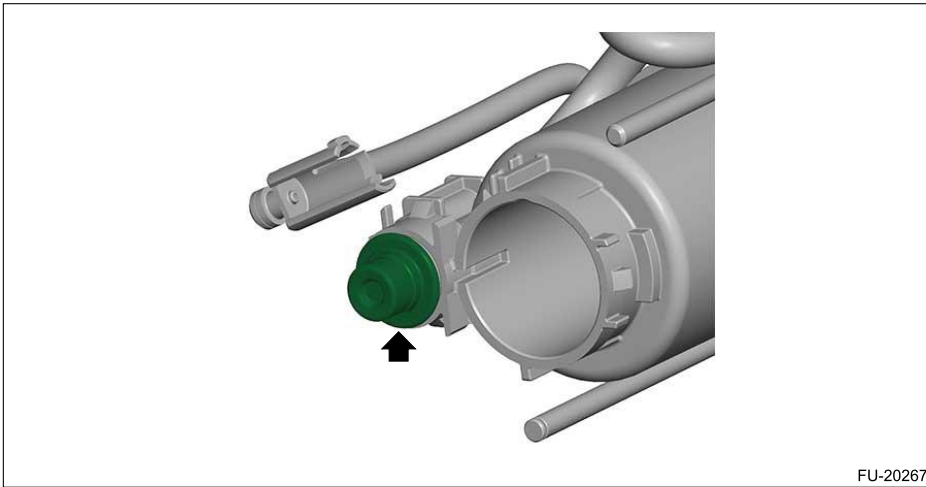
Note:

Apply gasoline to the O-ring and backup ring.



FU-07274

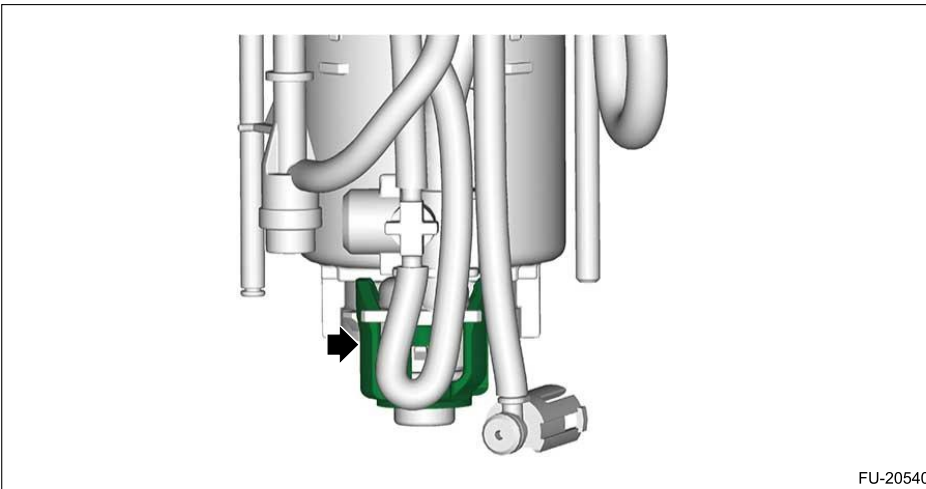
2. Install the pressure regulator to the fuel filter assembly.



3. Install the pressure regulator cap.

Note:

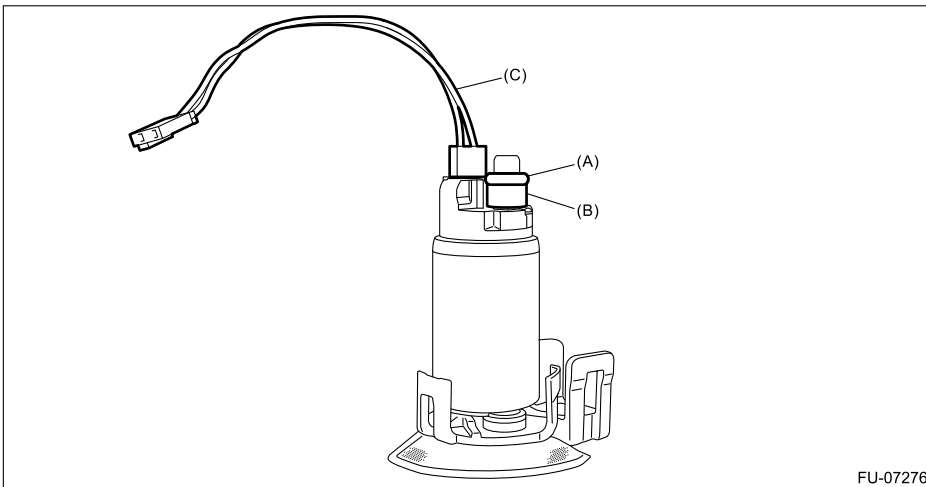
After installation, make sure 3 claws are securely engaged in each position.



4. Install new connector cable (C), spacer (B) and new O-ring (A) to the fuel pump.

Note:

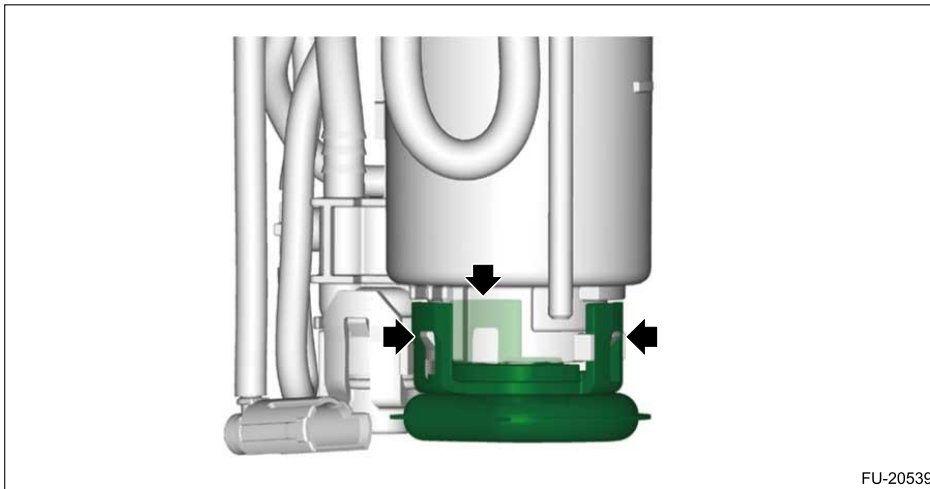
Apply gasoline to the O-rings and the spacer.



5. Install the fuel pump to the fuel filter assembly.

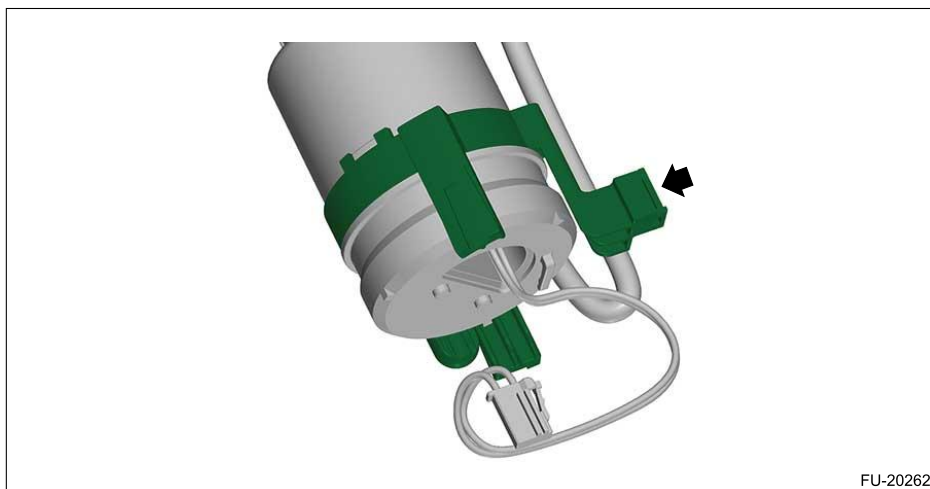
Note:

After installation, make sure 3 claws are securely engaged in each position.



FU-20539

6. Install the fuel pump holder.

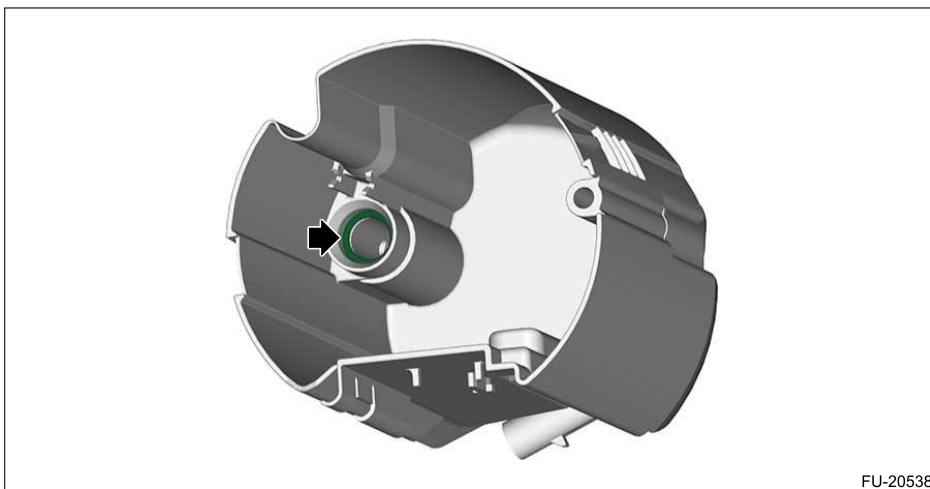


FU-20262

7. Install a new O-ring to the fuel chamber assembly.

Note:

Apply gasoline to the O-ring.



FU-20538

8. Install the tube assembly to the fuel chamber assembly.

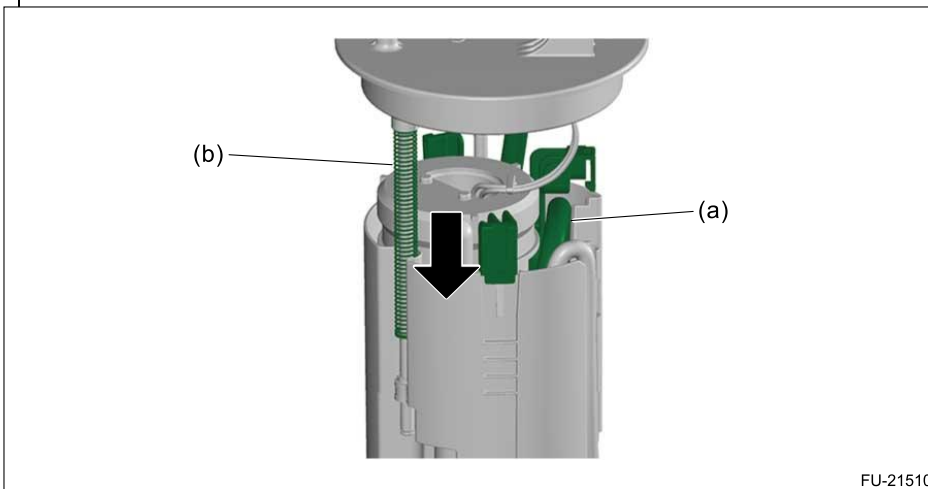


FU-20537

9. Install the fuel filter assembly to the fuel chamber assembly.

Note:

- Set the spring (b) and tube (a) for the fuel filter assembly as shown in the figure.



FU-21510

- Check that the claws fastening the fuel chamber assembly and the fuel filter assembly are securely engaged.



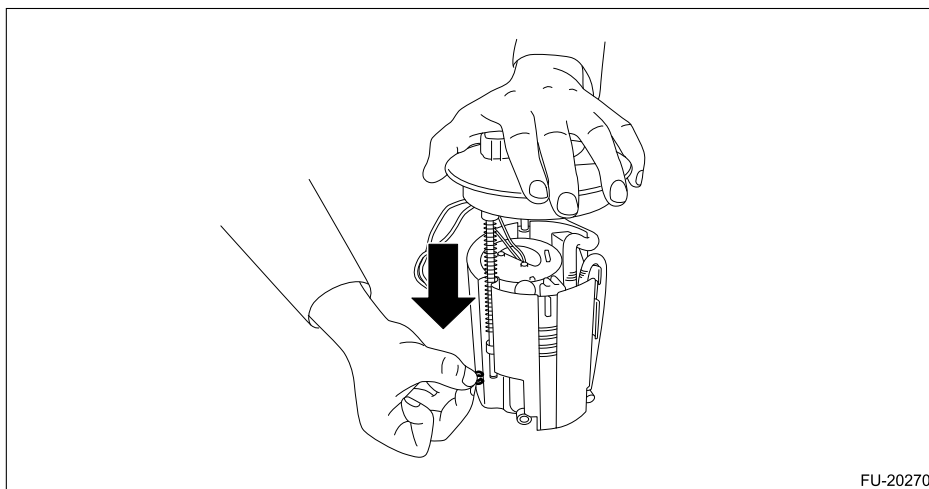
FU-20261

10. Connect the tube assembly to the fuel chamber assembly.

代替画像1

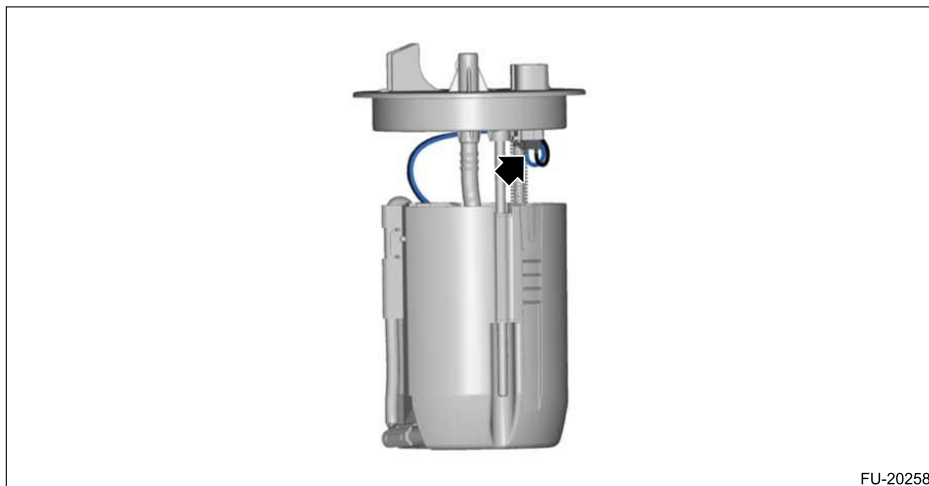
この画像は代替画像です

- 11.** Push the fuel filter assembly in the direction of the arrow to compress, and attach the new clip.






FU-20270

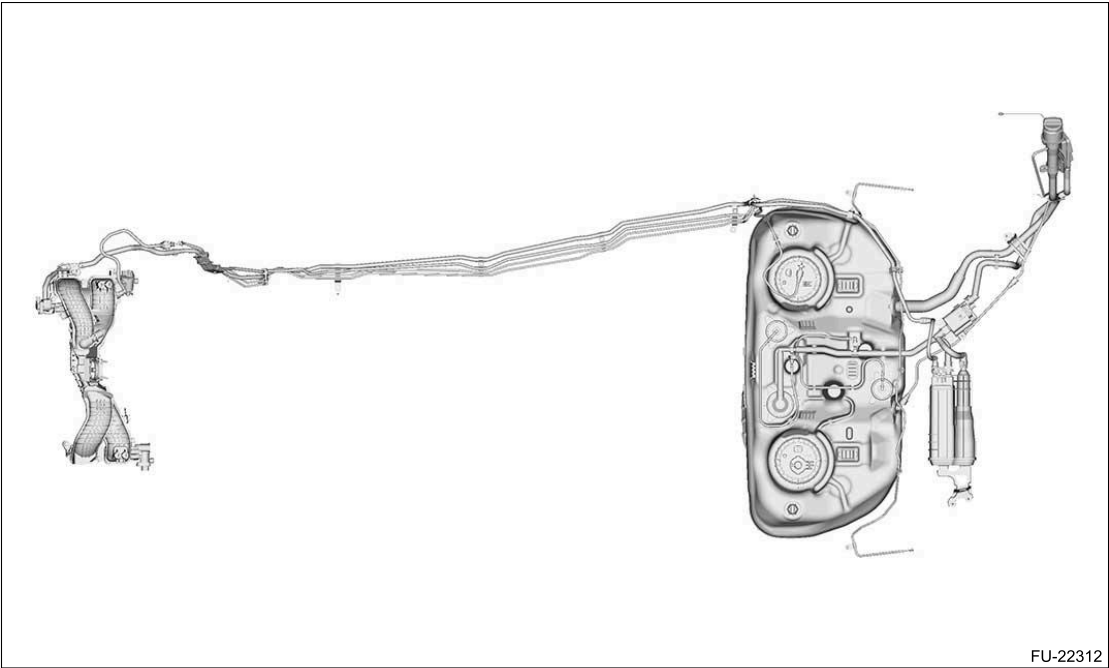
- 12.** Connect the connector cable.



FU-20258

- 13.** Install the fuel level sensor.  [Ref. to FUEL INJECTION \(FUEL SYSTEMS\)\(H4DOTC\)>Fuel Level Sensor>INSTALLATION.](#)
14. Inspect the fuel level sensor.  [Ref. to FUEL INJECTION \(FUEL SYSTEMS\)\(H4DOTC\)>Fuel Level Sensor>INSPECTION.](#)
15. Install the fuel pump assembly.  [Ref. to FUEL INJECTION \(FUEL SYSTEMS\)\(H4DOTC\)>Fuel Pump Assembly>INSTALLATION.](#)

REMOVAL



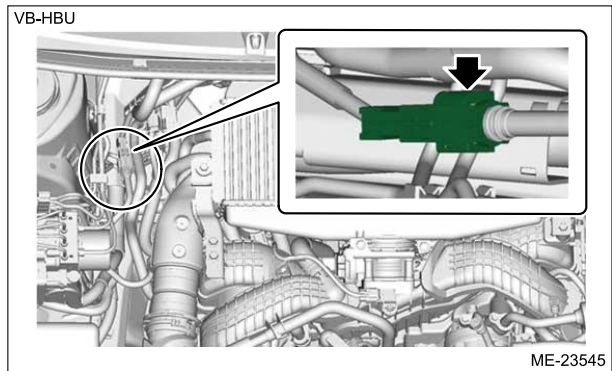
Warning:
Place "NO OPEN FLAMES" signs near the working area.

Caution:
Be careful not to spill fuel.

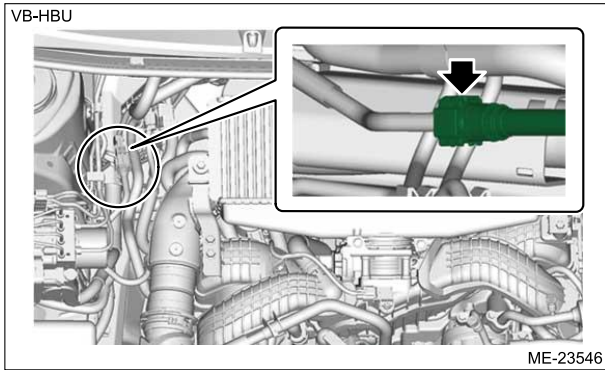
1. Release the fuel pressure. Ref. to [FUEL INJECTION \(FUEL SYSTEMS\)\(H4DOTC\)>Fuel>PROCEDURE > RELEASING OF FUEL PRESSURE.](#)
2. Drain fuel. Ref. to [FUEL INJECTION \(FUEL SYSTEMS\)\(H4DOTC\)>Fuel>PROCEDURE > DRAINING FUEL \(WITH SUBARU SELECT MONITOR\).](#)
3. Disconnect the ground terminal from battery sensor. Ref. to [REPAIR CONTENTS>NOTE > BATTERY.](#)
4. Open the fuel filler lid and remove the fuel filler cap.

Note:
This operation is required to release the inner pressure of the fuel tank.

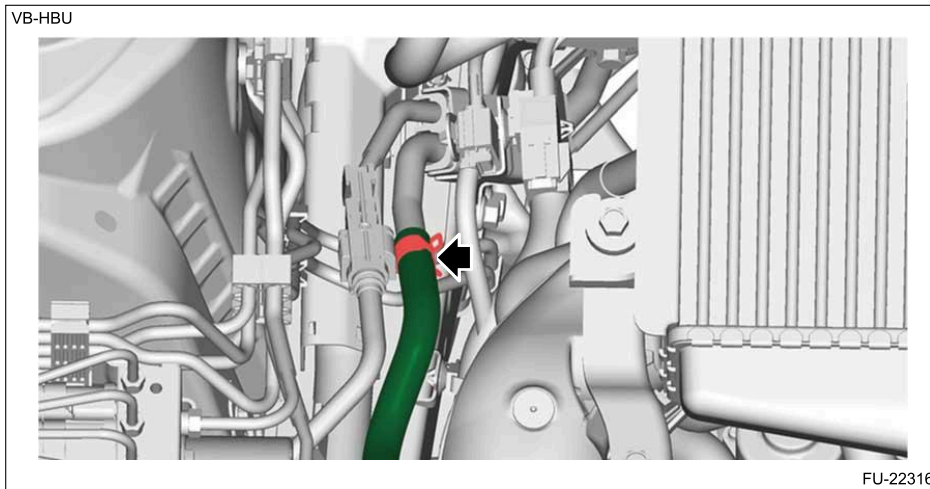
5. Remove the fuel delivery tube clamp from the fuel delivery tube.



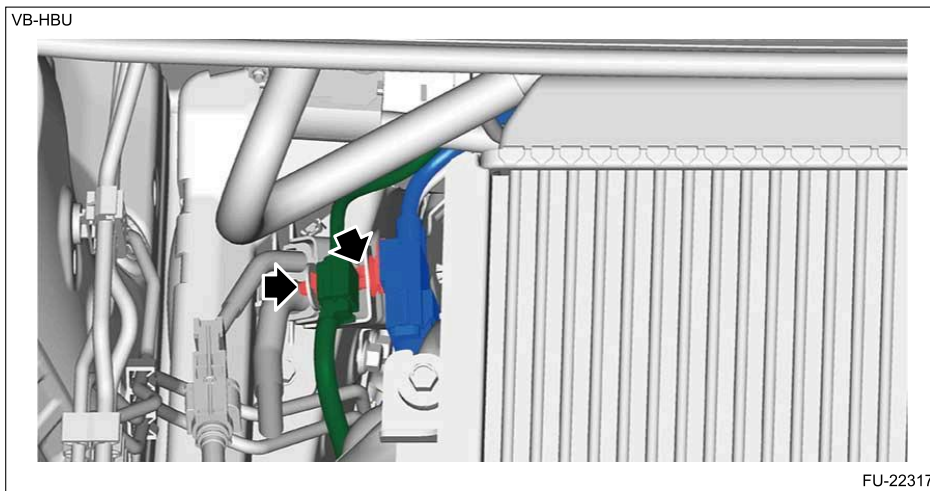
6. Disconnect the quick connector on the fuel delivery tube from the fuel pipe assembly. Ref. to [FUEL INJECTION \(FUEL SYSTEMS\)\(H4DOTC\)>Fuel Delivery and Evaporation Lines>REMOVAL > QUICK CONNECTOR DISCONNECTION \(TYPE A\).](#)



7. Disconnect the evaporation hose from the fuel pipe assembly.

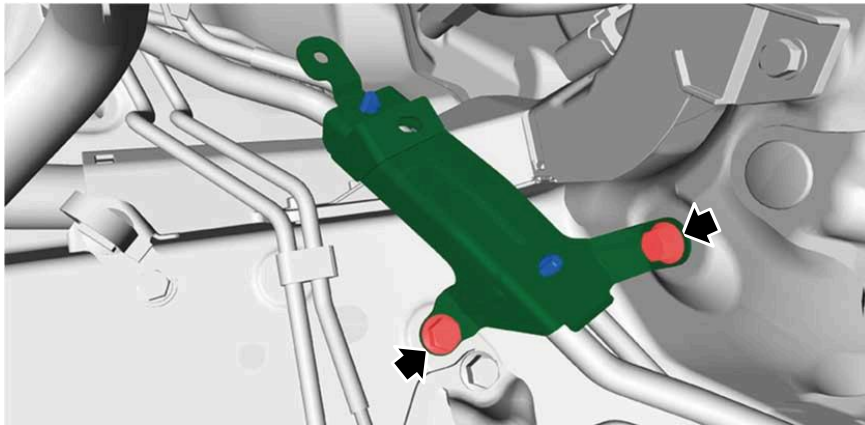


8. Remove the connector from the fuel pipe bracket A.



9. Lift up the vehicle.
10. Remove the bolts securing the fuel bracket A, and remove the pipe clamp from the fuel pipe assembly.

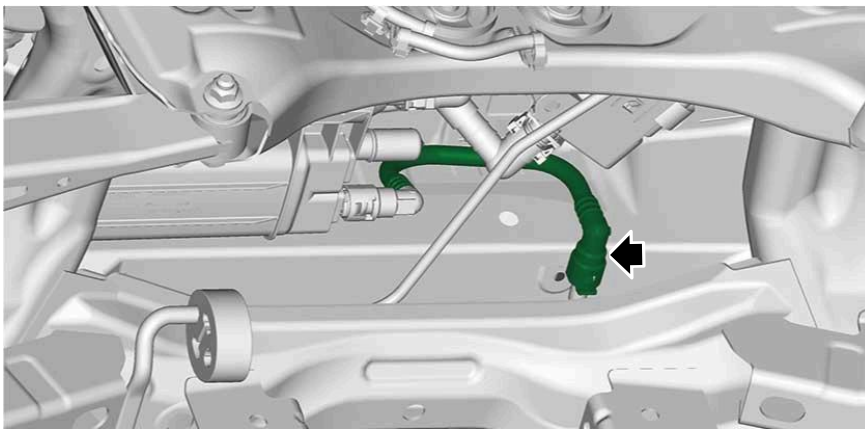
VB-HBU



FU-22318

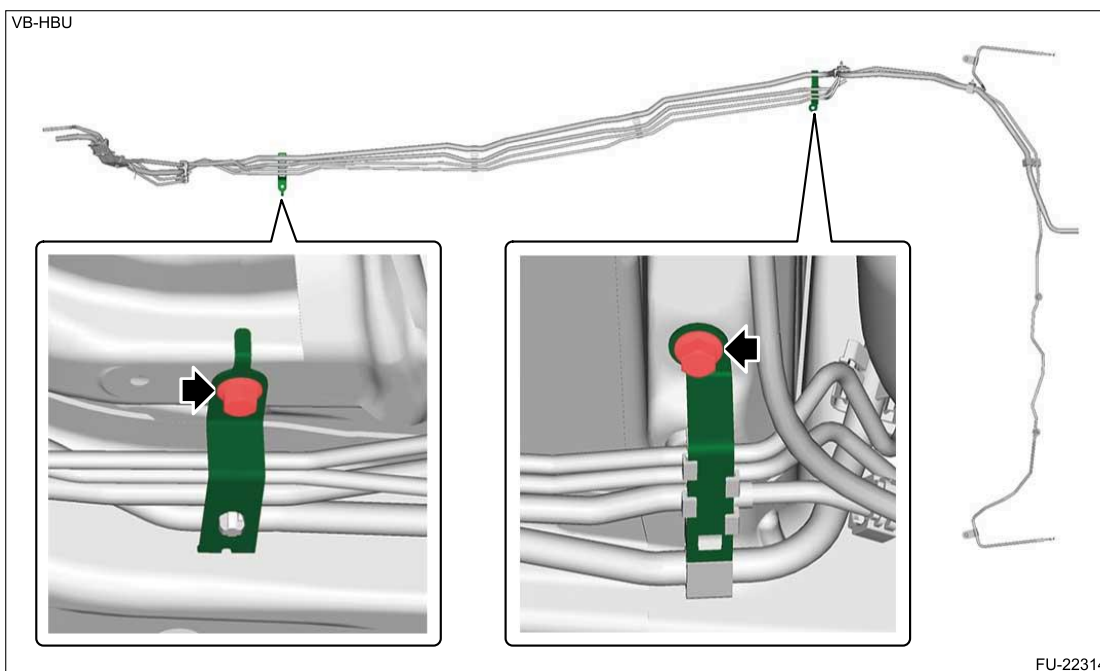
11. Remove the fuel tank. [🔗 Ref. to FUEL INJECTION \(FUEL SYSTEMS\)\(H4DOTC\)>Fuel Tank>REMOVAL.](#)
12. Remove the hoses from the fuel tank. [🔗 Ref. to FUEL INJECTION \(FUEL SYSTEMS\)\(H4DOTC\)>General Description>COMPONENT > FUEL TANK 1.](#)
 - For information about disconnecting fuel delivery tube, refer to "Fuel Delivery and Evaporation Lines". [🔗 Ref. to FUEL INJECTION \(FUEL SYSTEMS\)\(H4DOTC\)>Fuel Delivery and Evaporation Lines>REMOVAL > QUICK CONNECTOR DISCONNECTION \(TYPE D\).](#)
 - For information about disconnecting the circulate tube, refer to "Fuel Delivery and Evaporation Lines". [🔗 Ref. to FUEL INJECTION \(FUEL SYSTEMS\)\(H4DOTC\)>Fuel Delivery and Evaporation Lines>REMOVAL > QUICK CONNECTOR DISCONNECTION \(TYPE D\).](#)
13. Disconnect the purge tube from the fuel pipe assembly. [🔗 Ref. to FUEL INJECTION \(FUEL SYSTEMS\)\(H4DOTC\)>Fuel Delivery and Evaporation Lines>REMOVAL > QUICK CONNECTOR DISCONNECTION \(TYPE D\).](#)

VB-HBU

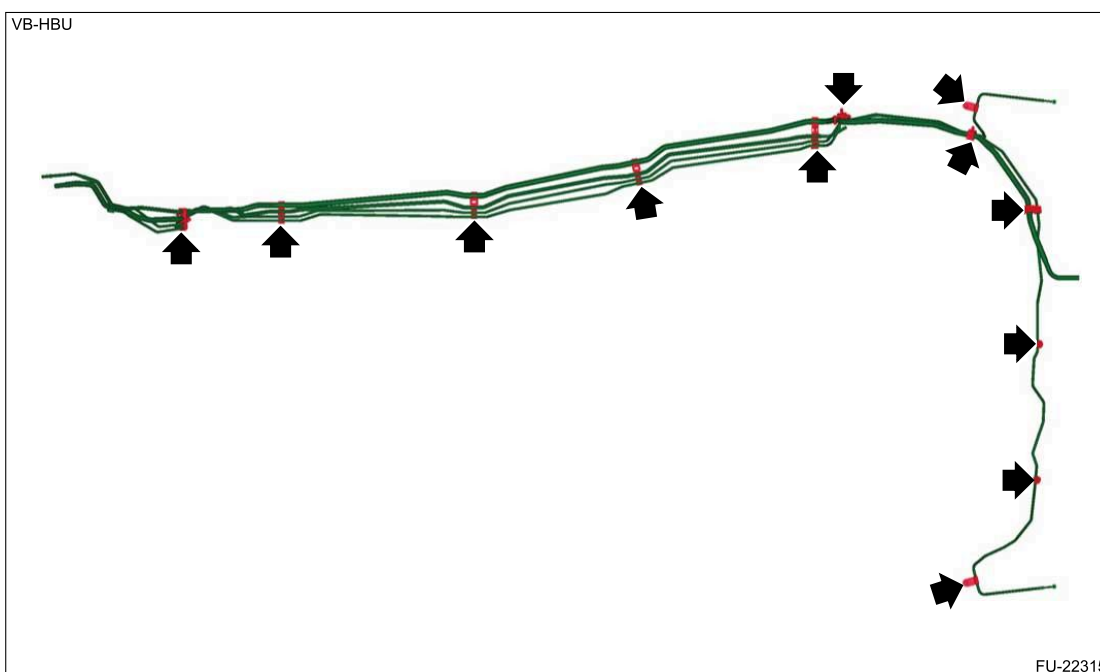


FU-22319



14. Remove the under cover rear RH. [🔗 Ref. to EXTERIOR/INTERIOR TRIM>Floor Under Protector>REMOVAL.](#)
15. Disconnect the brake hose and the brake pipe.
 - Brake hose:**
[🔗 Ref. to BRAKE>Brake Hose>REMOVAL.](#)
 - Brake pipe:**
[🔗 Ref. to BRAKE>Brake Pipe>REMOVAL.](#)
16. Remove the bolts securing the fuel pipe bracket B and the fuel pipe bracket C, and remove the pipe clamp from the fuel pipe assembly.



17. Remove the fuel pipe assembly.



18. Remove the fuel sub delivery tube.

- (1) Remove the fuel pump assembly.  [Ref. to FUEL INJECTION \(FUEL SYSTEMS\)\(H4DOTC\)>Fuel Pump Assembly>REMOVAL.](#)
- (2) Remove the fuel sub level sensor.  [Ref. to FUEL INJECTION \(FUEL SYSTEMS\)\(H4DOTC\)>Fuel Sub Level Sensor>REMOVAL.](#)
- (3) Remove the fuel sub delivery tube from the fuel tank.

1. QUICK CONNECTOR DISCONNECTION (TYPE A)

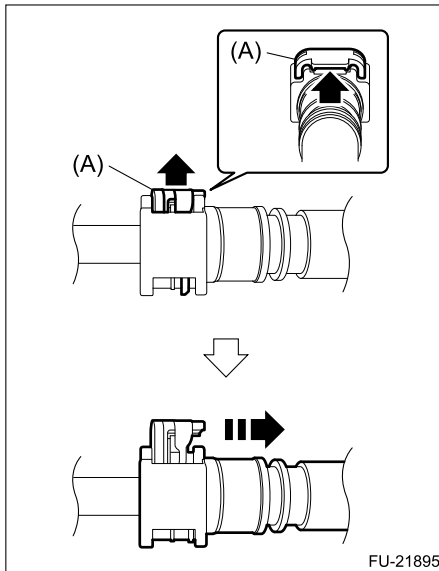
- 1.** Disconnect the quick connector as shown in the figure.

Caution:

- Be careful not to spill fuel.
- Catch the fuel from the tubes using a container or cloth.
- Pull out the quick connector straight in the axis direction.
- When disconnecting the quick connector, do not bend or twist the tube forcibly. If the tube is bent, replace it with a new part.

Note:

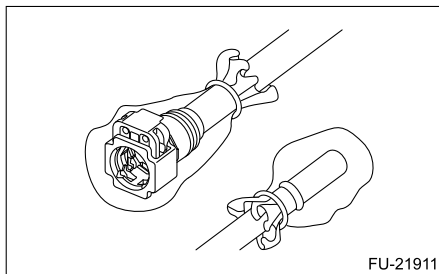
Clean the pipe and quick connector, if they are covered with dust or dirt.



2. Protect the quick connector and pipe with vinyl or other materials.

Caution:

Do not damage the quick connector and pipe or allow foreign matter to enter the pipe.



2. QUICK CONNECTOR DISCONNECTION (TYPE B)

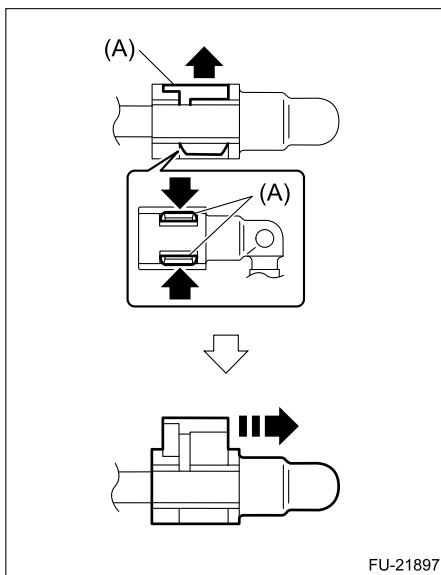
1. Disconnect the quick connector as shown in the figure.

Caution:

- Be careful not to spill fuel.
- Catch the fuel from the tubes using a container or cloth.
- Pull out the quick connector straight in the axis direction.
- When disconnecting the quick connector, do not bend or twist the tube forcibly. If the tube is bent, replace it with a new part.

Note:

Clean the pipe and quick connector, if they are covered with dust or dirt.

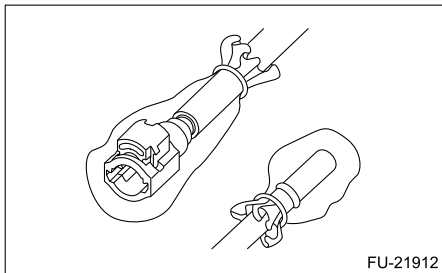


(A) Slider

2. Protect the quick connector and pipe with vinyl or other materials.

Caution:

Do not damage the quick connector and pipe or allow foreign matter to enter the pipe.



3. QUICK CONNECTOR DISCONNECTION (TYPE C)

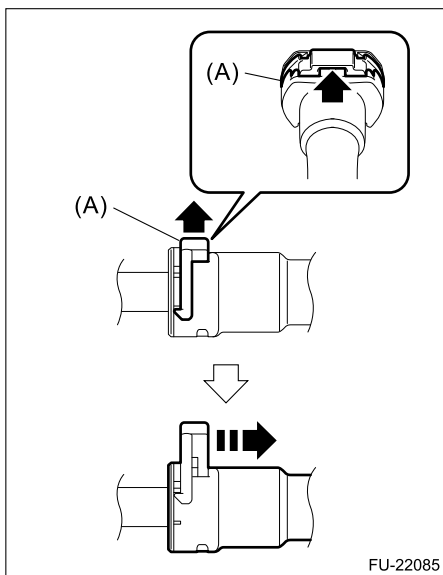
1. Disconnect the quick connector as shown in the figure.

Caution:

- Be careful not to spill fuel.
- Catch the fuel from the tubes using a container or cloth.
- Pull out the quick connector straight in the axis direction.
- When disconnecting the quick connector, do not bend or twist the tube forcibly. If the tube is bent, replace it with a new part.

Note:

Clean the pipe and quick connector, if they are covered with dust or dirt.

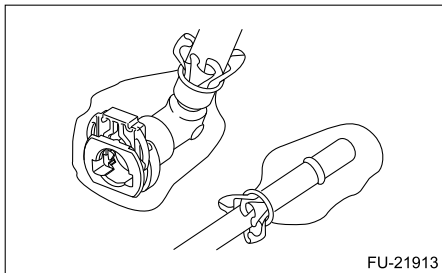


(A) Slider

2. Protect the quick connector and pipe with vinyl or other materials.

Caution:

Do not damage the quick connector and pipe or allow foreign matter to enter the pipe.



4. QUICK CONNECTOR DISCONNECTION (TYPE D)

- When using ST

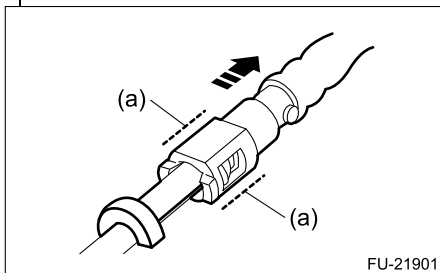
1. Attach the ST to the pipe and push the ST in the direction of arrow mark to disconnect the quick connector.

Preparation tool:

ST: QUICK CONNECTOR RELEASE (42099AE000)

Caution:

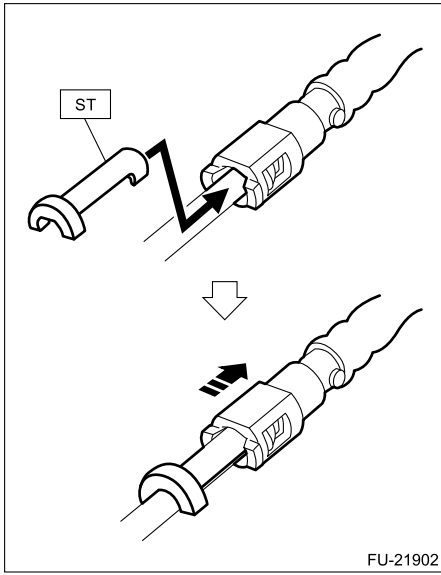
- Be careful not to spill fuel.
- Catch the fuel from the tubes using a container or cloth.
- If the quick connector and pipe are sticking to each other, push and pull the connector with the ST pushed, and then pull the connector after it starts moving freely.
- Pull out the quick connector straight in the axis direction by holding the section (a) as shown in the figure.



- When disconnecting the quick connector, do not bend or twist the tube forcibly. If the tube is bent, replace it with a new part.

Note:

Clean the pipe and quick connector, if they are covered with dust or dirt.

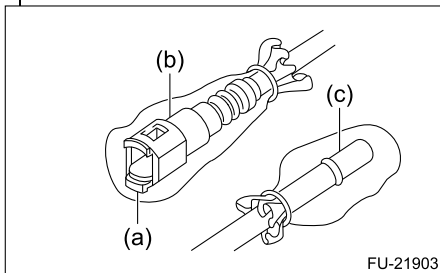


FU-21902

2. Protect the quick connector and pipe with vinyl or other materials.

Caution:

- Do not damage the quick connector and pipe or allow foreign matter to enter the pipe.
- When reusing the retainer, do not disconnect the retainer from the connector.



FU-21903

(a) Retainer

(b) Connector

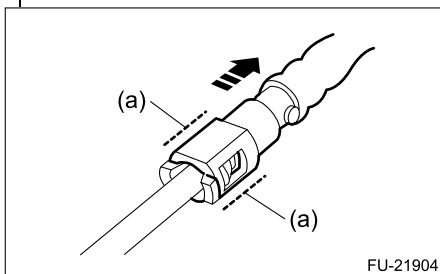
(c) Pipe

• When not using ST

1. Push the retainer in the direction of the arrow, disconnect the quick connector from pipe.

Caution:

- Be careful not to spill fuel.
- Catch the fuel from the tubes using a container or cloth.
- If the quick connector and pipe are sticking to each other, push and pull the connector with the retainer pushed in the direction of the arrow, and then pull the connector after it starts moving freely.
- Pull out the quick connector straight in the axis direction by holding the section (a) as shown in the figure.

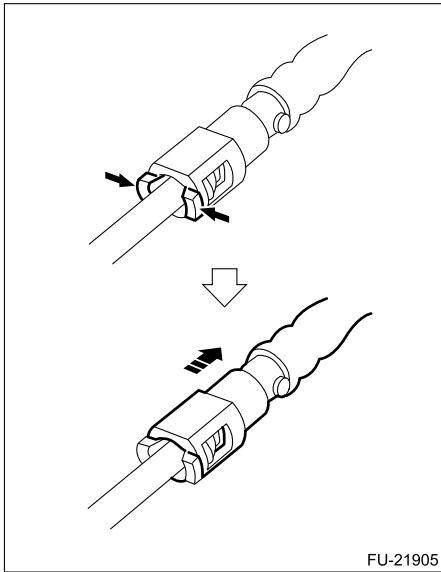


FU-21904

- When disconnecting the quick connector, do not bend or twist the tube forcibly. If the tube is bent, replace it with a new part.

Note:

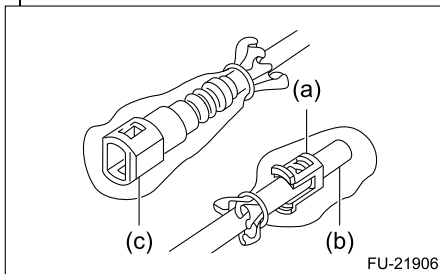
Clean the pipe and quick connector, if they are covered with dust or dirt.



2. Protect the quick connector and pipe with vinyl or other materials.

Caution:

- Do not damage the quick connector and pipe or allow foreign matter to enter the pipe.
- When reusing the retainer, do not disconnect the retainer from the pipe.



(a) Retainer

(b) Pipe

(c) Connector

5. QUICK CONNECTOR DISCONNECTION (TYPE E)

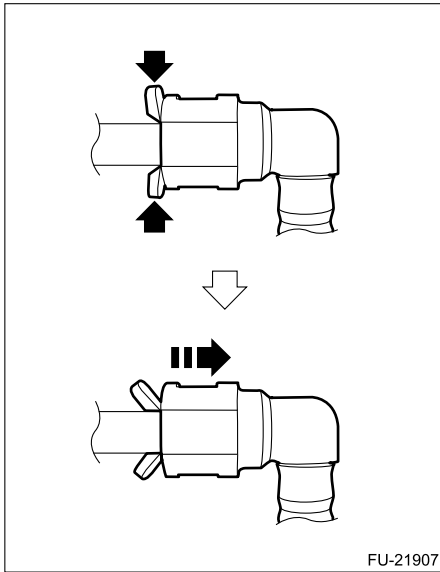
1. Disconnect the quick connector as shown in the figure.

Caution:

- Pull out the quick connector straight in the axis direction.
- When disconnecting the quick connector, do not bend or twist the tube forcibly. If the tube is bent, replace it with a new part.

Note:

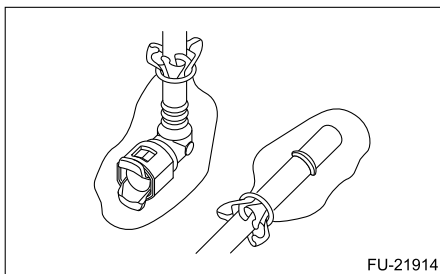
Clean the pipe and quick connector, if they are covered with dust or dirt.



2. Protect the quick connector and pipe with vinyl or other materials.

Caution:

Do not damage the quick connector and pipe or allow foreign matter to enter the pipe.



6. QUICK CONNECTOR DISCONNECTION (TYPE F)

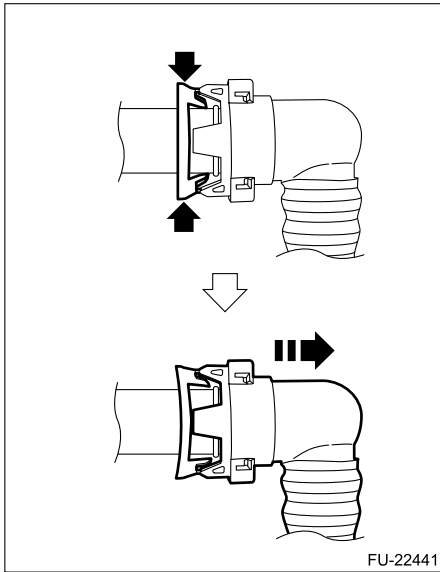
1. Disconnect the quick connector as shown in the figure.

Caution:

- Pull out the quick connector straight in the axis direction.
- When disconnecting the quick connector, do not bend or twist the tube forcibly. If the tube is bent, replace it with a new part.

Note:

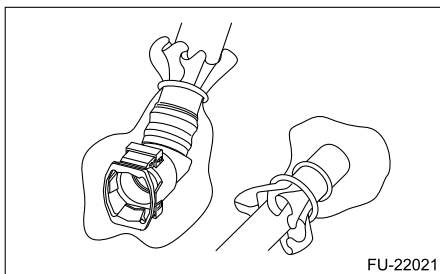
Clean the pipe and quick connector, if they are covered with dust or dirt.



2. Protect the quick connector and pipe with vinyl or other materials.

Caution:

Do not damage the quick connector and pipe or allow foreign matter to enter the pipe.



7. QUICK CONNECTOR DISCONNECTION (TYPE G)

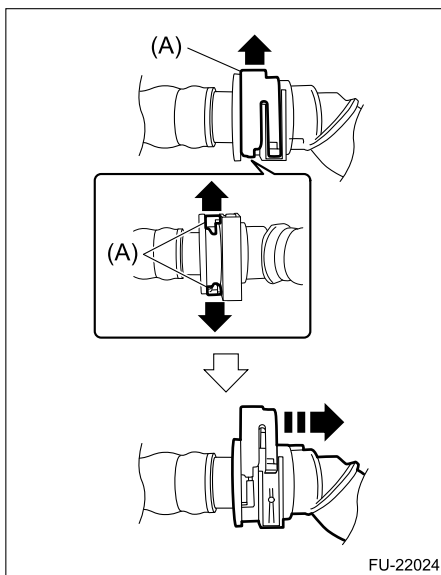
1. Disconnect the quick connector as shown in the figure.

Caution:

- Pull out the quick connector straight in the axis direction.
- When disconnecting the quick connector, do not bend or twist the tube forcibly. If the tube is bent, replace it with a new part.

Note:

Clean the pipe and quick connector, if they are covered with dust or dirt.

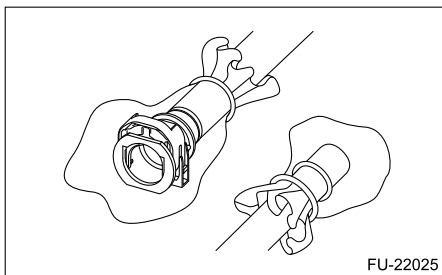


(A) Slider

2. Protect the quick connector and pipe with vinyl or other materials.

Caution:

Do not damage the quick connector and pipe or allow foreign matter to enter the pipe.



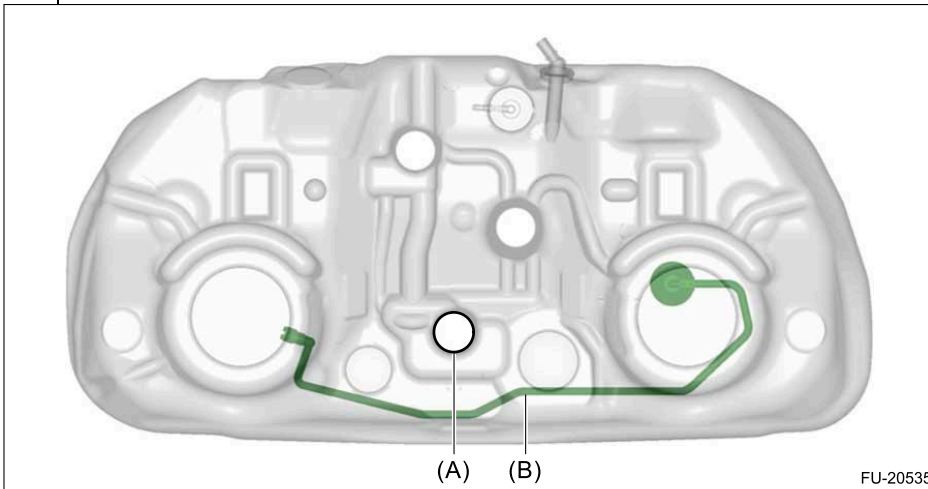
FUEL INJECTION (FUEL SYSTEMS)(H4DOTC) > Fuel Delivery and Evaporation Lines

INSTALLATION

1. Install the fuel sub delivery tube.
 - (1) Set the fuel sub delivery tube to the fuel tank.

Note:



- Route the fuel sub delivery tube in front of the stand-off as shown in the figure.
- Check the fuel sub delivery tube to make sure it's not twisted.



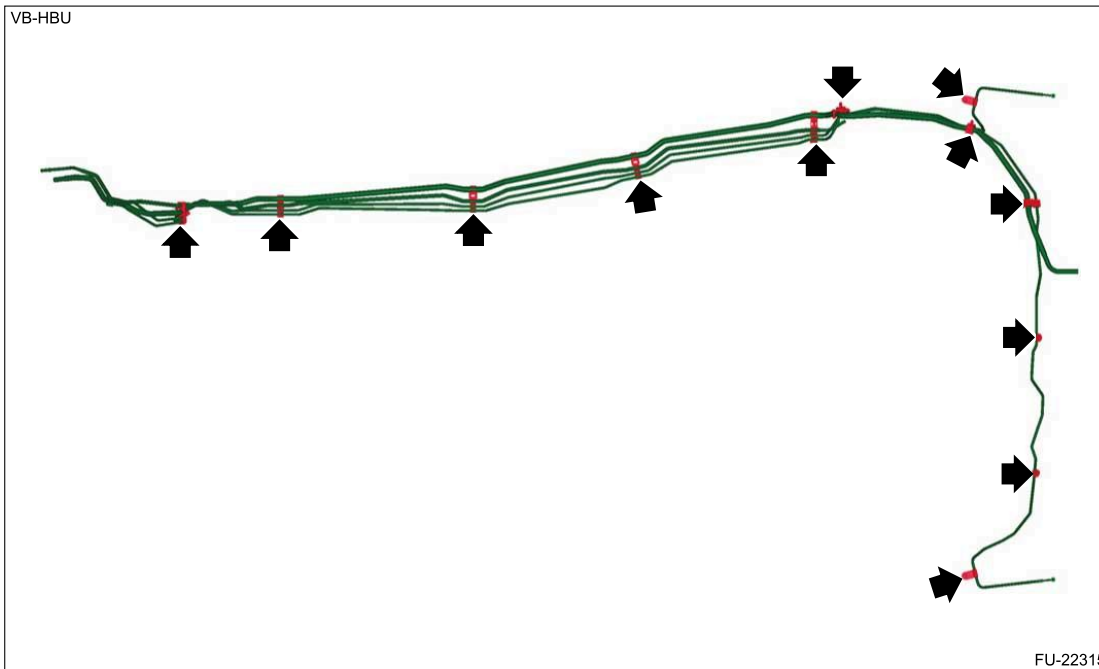
FU-20535

(A) Stand-off

(B) Fuel sub delivery tube

- (2) Install the fuel sub level sensor.  [Ref. to FUEL INJECTION \(FUEL SYSTEMS\)\(H4DOTC\)>Fuel Sub Level Sensor>INSTALLATION.](#)
- (3) Install the fuel pump assembly.  [Ref. to FUEL INJECTION \(FUEL SYSTEMS\)\(H4DOTC\)>Fuel Pump Assembly>INSTALLATION.](#)

2. Install the fuel pipe assembly.

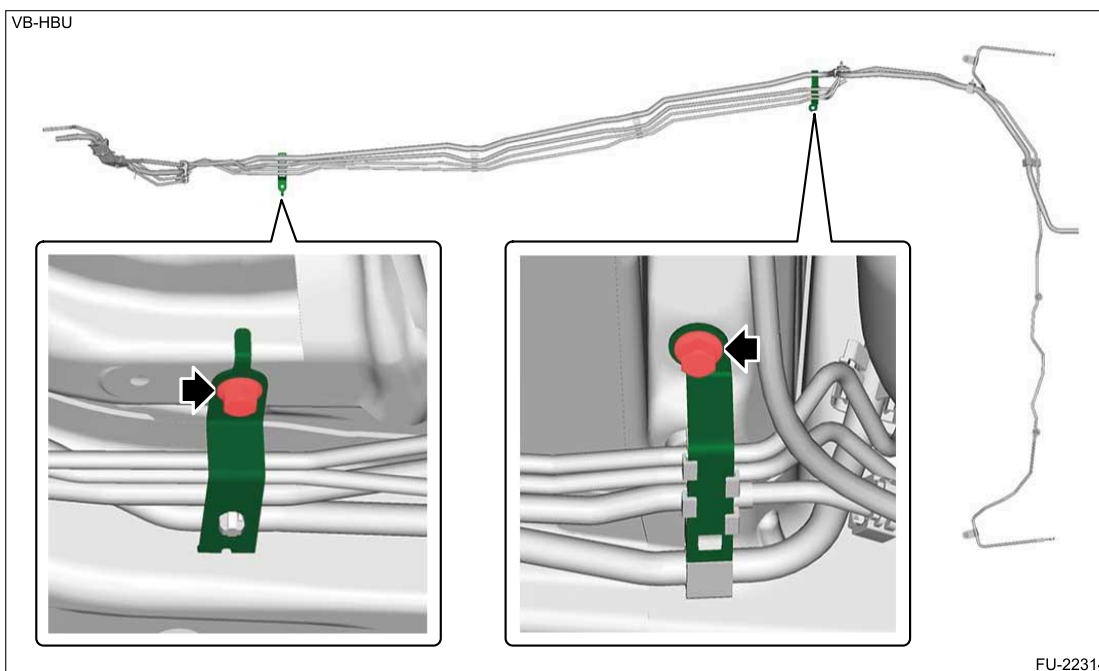


FU-22315

3. Install the pipe clamp to the fuel pipe assembly, and then install the fuel pipe bracket B and fuel pipe bracket C.

Tightening torque:

18 N·m (1.8 kgf-m, 13.3 ft-lb)



4. Connect the brake pipe and brake hose.

Brake pipe:

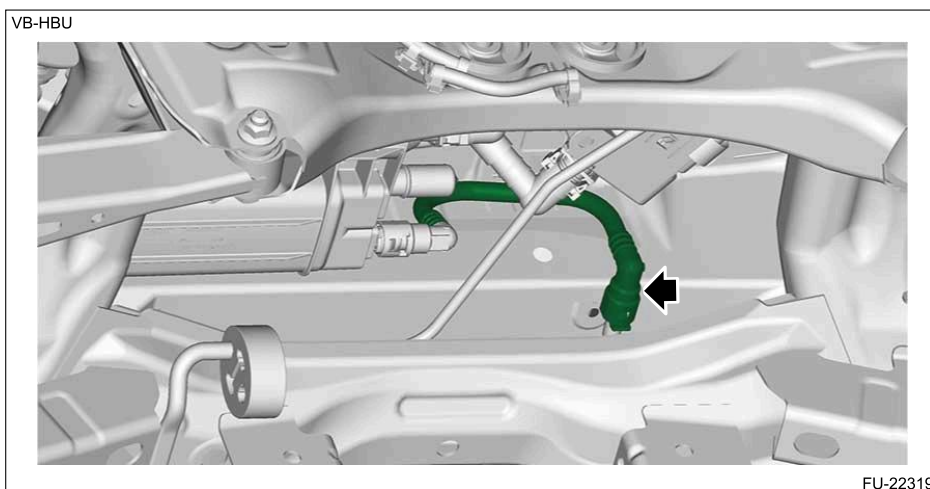
[Ref. to BRAKE>Brake Pipe>INSTALLATION.](#)

Brake hose:

[Ref. to BRAKE>Brake Hose>INSTALLATION.](#)

5. Install the under cover rear RH. [Ref. to EXTERIOR/INTERIOR TRIM>Floor Under Protector>INSTALLATION.](#)

6. Connect the purge tube to the fuel pipe assembly. [Ref. to FUEL INJECTION \(FUEL SYSTEMS\)\(H4DOTC\)>Fuel Delivery and Evaporation Lines>INSTALLATION > QUICK CONNECTOR CONNECTION \(TYPE D\).](#)



7. Connect individual hoses and tubes to the fuel tank. [Ref. to FUEL INJECTION \(FUEL SYSTEMS\)\(H4DOTC\)>General Description>COMPONENT > FUEL TANK 1.](#)

- For information about connecting fuel delivery tube, refer to "Fuel Delivery and Evaporation Lines". [Ref. to FUEL INJECTION \(FUEL SYSTEMS\)\(H4DOTC\)>Fuel Delivery and Evaporation Lines>INSTALLATION > QUICK CONNECTOR CONNECTION \(TYPE D\).](#)
- For information about connecting the circulate tube, refer to "Fuel Delivery and Evaporation Lines". [Ref. to FUEL INJECTION \(FUEL SYSTEMS\)\(H4DOTC\)>Fuel Delivery and Evaporation Lines>INSTALLATION > QUICK CONNECTOR CONNECTION \(TYPE D\).](#)

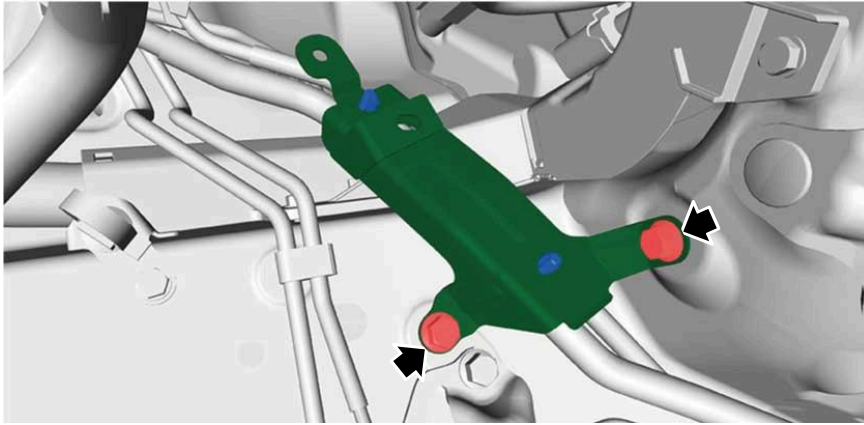
8. Install the fuel tank. [Ref. to FUEL INJECTION \(FUEL SYSTEMS\)\(H4DOTC\)>Fuel Tank>INSTALLATION.](#)

9. Install the pipe clamp to the fuel pipe assembly, and then install the fuel pipe bracket A.

Tightening torque:

18 N·m (1.8 kgf-m, 13.3 ft-lb)

VB-HBU

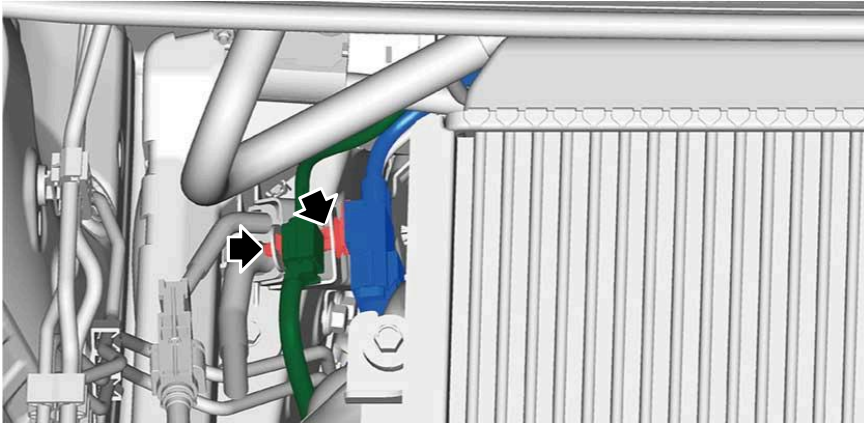


FU-22318

10. Lower the vehicle.

11. Install the connector to the fuel pipe bracket A.

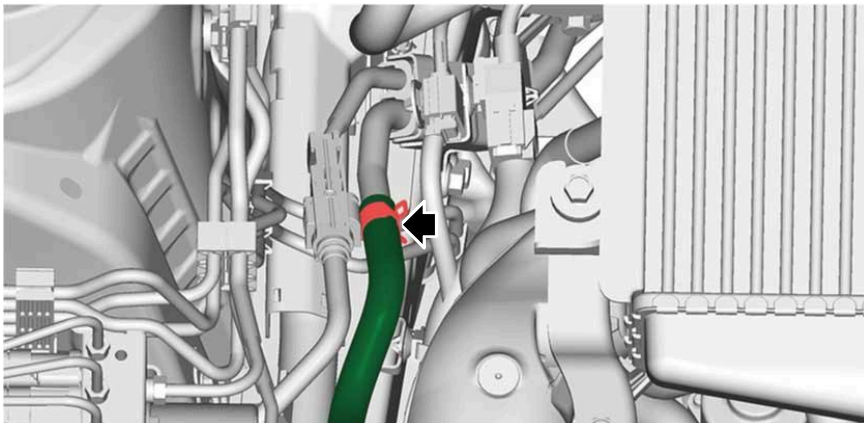
VB-HBU




FU-22317

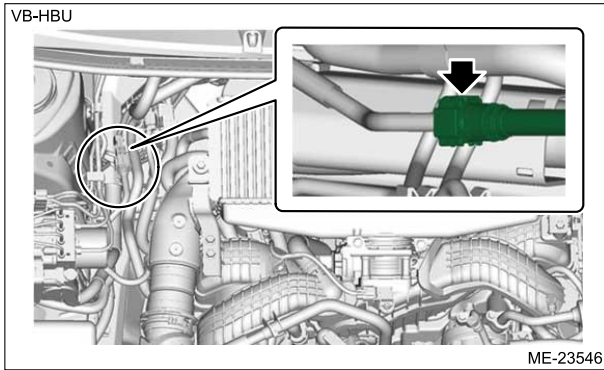
12. Connect the evaporation hose to fuel pipe assembly.

VB-HBU

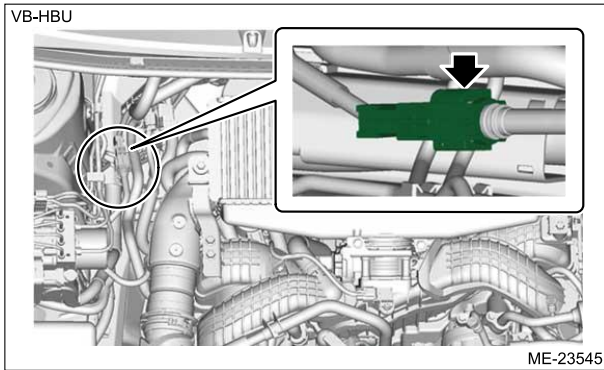


FU-22316

13. Connect the quick connector on the fuel delivery tube to the fuel pipe assembly.  [Ref. to FUEL INJECTION \(FUEL SYSTEMS\) \(H4DOTC\)>Fuel Delivery and Evaporation Lines>INSTALLATION > QUICK CONNECTOR CONNECTION \(TYPE A\).](#)



14. Install the fuel delivery tube clamp to the fuel delivery tube.



15. Connect the ground terminal to battery sensor.  [Ref. to REPAIR CONTENTS>NOTE > BATTERY.](#)

1. QUICK CONNECTOR CONNECTION (TYPE A)

1. Check the seal surfaces of the quick connector and pipe for damage or deformation.

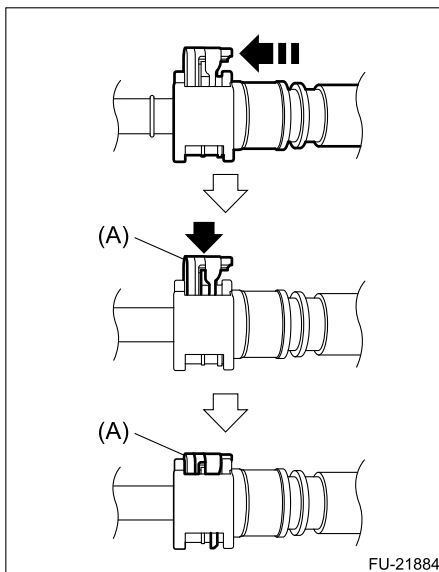
Caution:

Check that there is no damage or dust on the quick connector. If necessary, clean the seal surface of the pipe.

2. Connect the quick connector as shown in the figure.

Caution:

- **Press in the quick connector straight in the axis direction.**
- **When connecting the quick connector, do not bend or twist the tube forcibly. If the tube is bent, replace it with a new part.**
- **When connecting the quick connector, make sure to insert it all the way in before locking the slider.**
- **When it is difficult to lock the slider, check that the connector is fully inserted.**

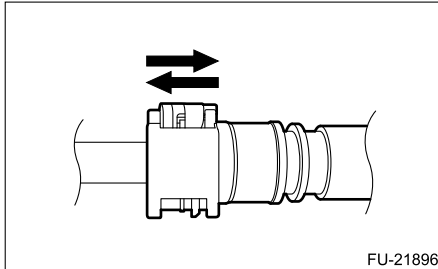


(A) Slider

3. Make sure that the quick connector is securely connected by pushing and pulling the connector.

Caution:

- After locking the slider, pull the quick connector itself to the disconnecting direction, and then push to the connecting direction in order to confirm secure connection. Always make sure to perform this confirmation ending up with a pushing in.
- Be sure to inspect tubes and their connections for any leakage of fuel.



2. QUICK CONNECTOR CONNECTION (TYPE B)

1. Check the seal surfaces of the quick connector and pipe for damage or deformation.

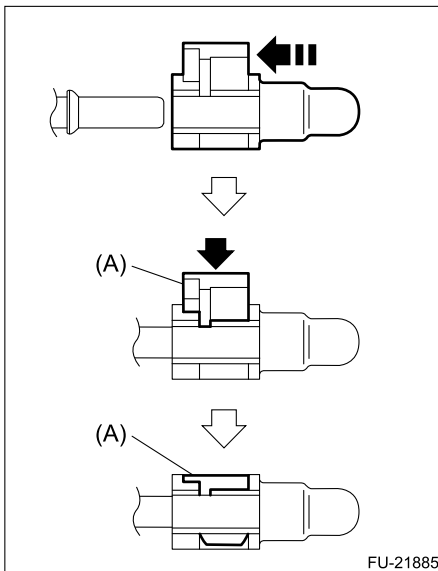
Caution:

Check that there is no damage or dust on the quick connector. If necessary, clean the seal surface of the pipe.

2. Connect the quick connector as shown in the figure.

Caution:

- Press in the quick connector straight in the axis direction.
- When connecting the quick connector, do not bend or twist the tube forcibly. If the tube is bent, replace it with a new part.
- When connecting the quick connector, make sure to insert it all the way in before locking the slider.
- When it is difficult to lock the slider, check that the connector is fully inserted.

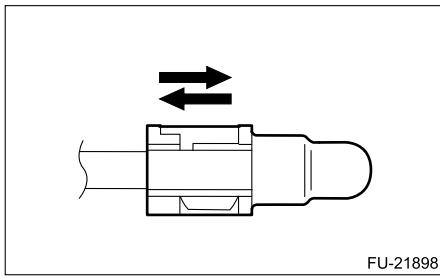


(A) Slider

3. Make sure that the quick connector is securely connected by pushing and pulling the connector.

Caution:

- After locking the slider, pull the quick connector itself to the disconnecting direction, and then push to the connecting direction in order to confirm secure connection. Always make sure to perform this confirmation ending up with a pushing in.
- Be sure to inspect tubes and their connections for any leakage of fuel.



3. QUICK CONNECTOR CONNECTION (TYPE C)

1. Check the seal surfaces of the quick connector and pipe for damage or deformation.

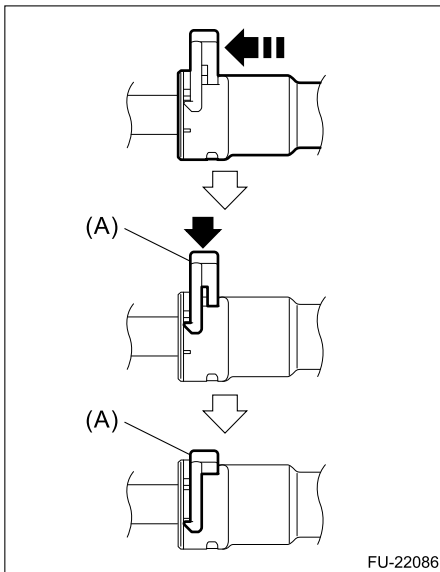
Caution:

Check that there is no damage or dust on the quick connector. If necessary, clean the seal surface of the pipe.

2. Connect the quick connector as shown in the figure.

Caution:

- Press in the quick connector straight in the axis direction.
- When connecting the quick connector, do not bend or twist the tube forcibly. If the tube is bent, replace it with a new part.
- When connecting the quick connector, make sure to insert it all the way in before locking the slider.
- When it is difficult to lock the slider, check that the connector is fully inserted.

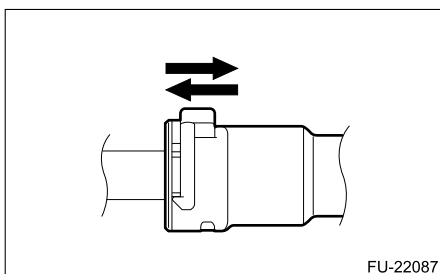


(A) Slider

3. Make sure that the quick connector is securely connected by pushing and pulling the connector.

Caution:

- After locking the slider, pull the quick connector itself to the disconnecting direction, and then push to the connecting direction in order to confirm secure connection. Always make sure to perform this confirmation ending up with a pushing in.
- Be sure to inspect tubes and their connections for any leakage of fuel.

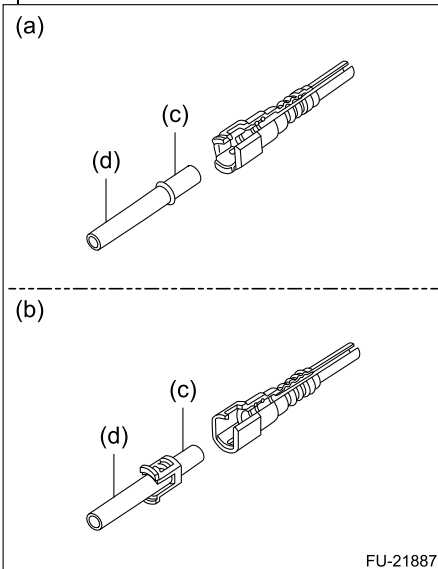


4. QUICK CONNECTOR CONNECTION (TYPE D)

1. Check the seal surfaces of the quick connector and pipe for damage or deformation.

Caution:

Check that there is no damage or dust on the quick connector. If necessary, clean the seal surface of the pipe.

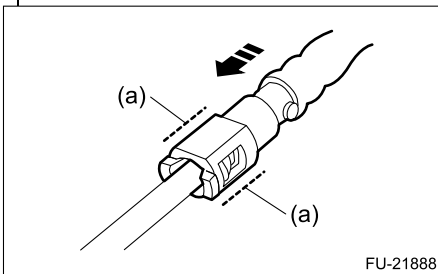


- (a) When removed using the ST (c) Seal surface (d) Pipe
- (b) When removed without using the ST

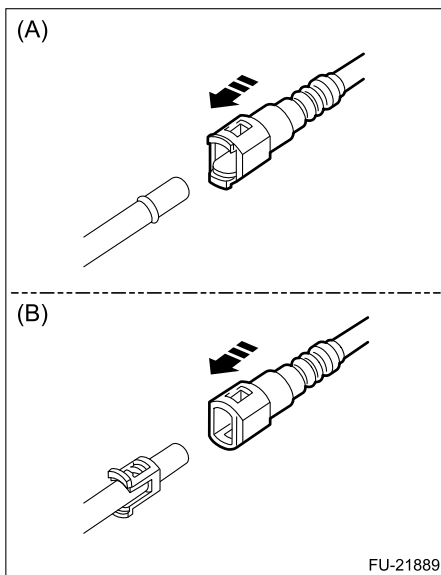
2. Connect the quick connector as shown in the figure.

Caution:

- **Make sure the two retainer pawls are engaged in their mating positions in the quick connector.**
- **When reusing the retainer, make sure that neither scratches nor deformation exist on the retainer. If it is faulty, use a new part.**
- **Press in the quick connector straight in the axis direction by holding the section (a) as shown in the figure.**



- **When connecting the quick connector, do not bend or twist the tube forcibly. If the tube is bent, replace it with a new part.**

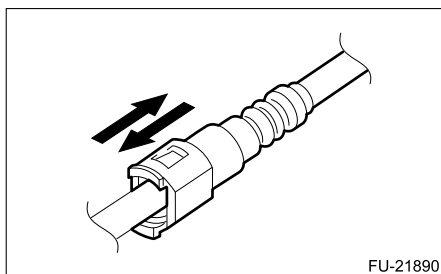


(A) When removed using the ST (B) When removed without using the ST

3. Make sure that the quick connector is securely connected by pushing and pulling the connector.

Caution:

- After connecting the quick connector, pull the quick connector body in the removal direction and then push it in the connecting direction, in order to check that the quick connector is securely connected. Always make sure to perform this confirmation ending up with a pushing in.
- Be sure to inspect tubes and their connections for any leakage of fuel.



5. QUICK CONNECTOR CONNECTION (TYPE E)

1. Check the seal surfaces of the quick connector and pipe for damage or deformation.

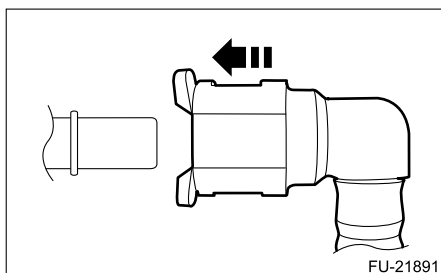
Caution:

Check that there is no damage or dust on the quick connector. If necessary, clean the seal surface of the pipe.

2. Connect the quick connector as shown in the figure.

Caution:

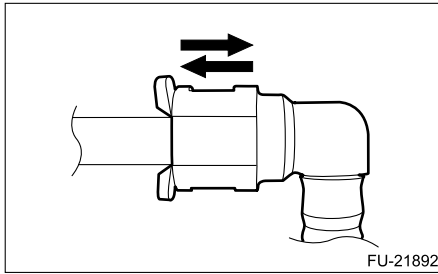
- Press in the quick connector straight in the axis direction.
- When connecting the quick connector, do not bend or twist the tube forcibly. If the tube is bent, replace it with a new part.



3. Make sure that the quick connector is securely connected by pushing and pulling the connector.

Caution:

After connecting the quick connector, pull the quick connector body in the removal direction and then push it in the connecting direction, in order to check that the quick connector is securely connected. Always make sure to perform this confirmation ending up with a pushing in.



6. QUICK CONNECTOR CONNECTION (TYPE F)

1. Check the seal surfaces of the quick connector and pipe for damage or deformation.

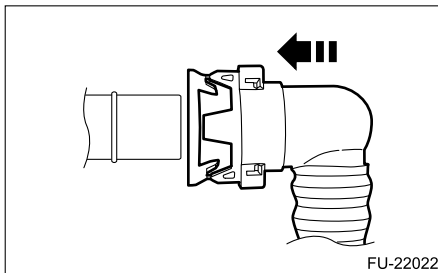
Caution:

Check that there is no damage or dust on the quick connector. If necessary, clean the seal surface of the pipe.

2. Connect the quick connector as shown in the figure.

Caution:

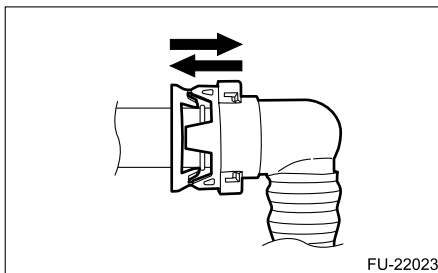
- Press in the quick connector straight in the axis direction.
- When connecting the quick connector, do not bend or twist the tube forcibly. If the tube is bent, replace it with a new part.



3. Make sure that the quick connector is securely connected by pushing and pulling the connector.

Caution:

After connecting the quick connector, pull the quick connector body in the removal direction and then push it in the connecting direction, in order to check that the quick connector is securely connected. Always make sure to perform this confirmation ending up with a pushing in.



7. QUICK CONNECTOR CONNECTION (TYPE G)

1. Check the seal surfaces of the quick connector and pipe for damage or deformation.

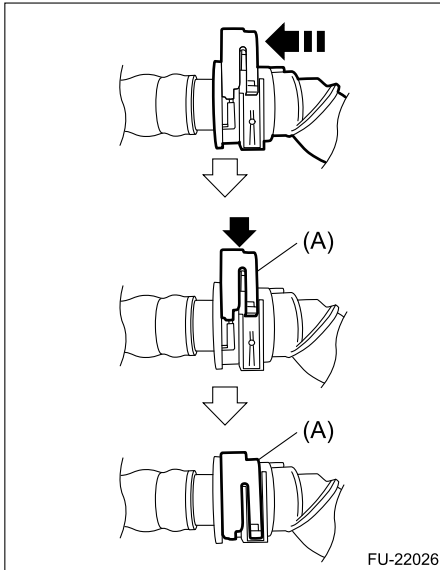
Caution:

Check that there is no damage or dust on the quick connector. If necessary, clean the seal surface of the pipe.

2. Connect the quick connector as shown in the figure.

Caution:

- Press in the quick connector straight in the axis direction.
- When connecting the quick connector, do not bend or twist the tube forcibly. If the tube is bent, replace it with a new part.
- When connecting the quick connector, make sure to insert it all the way in before locking the slider.
- When it is difficult to lock the slider, check that the connector is fully inserted.

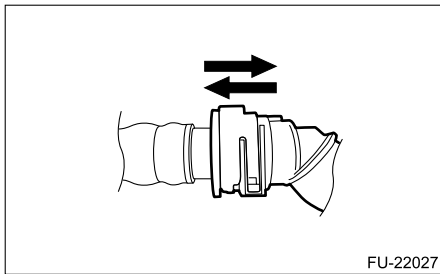


(A) Slider

3. Make sure that the quick connector is securely connected by pushing and pulling the connector.

Caution:

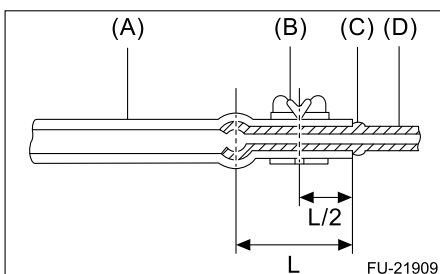
After locking the slider, pull the quick connector itself to the disconnecting direction, and then push to the connecting direction in order to confirm secure connection. Always make sure to perform this confirmation ending up with a pushing in.



FU-22027

8. EVAPORATION HOSE CONNECTION

Connect by inserting it to the pipe until it reaches the spool or bump.



(A) Hose

(C) Spool or bump

(D) Pipe

(B) Clip

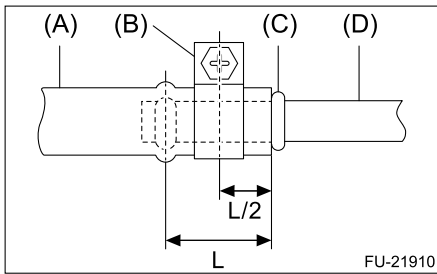
9. FUEL FILLER HOSE CONNECTION

● **FILLER PIPE SIDE**

Securely insert the hose to the spool, and then install the clamp as shown in the figure.

Tightening torque:

5 N·m (0.5 kgf-m, 3.7 ft-lb)



(A) Fuel filler hose

(C) Spool

(D) Fuel filler pipe

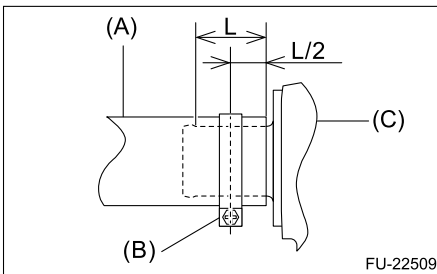
(B) Clamp

● **FUEL TANK SIDE**

Insert the fuel filler hose and install the clamp as shown in the figure.

Tightening torque:

2 N·m (0.2 kgf-m, 1.5 ft-lb)



(A) Fuel filler hose

(B) Clamp

(C) Fuel tank

FUEL INJECTION (FUEL SYSTEMS)(H4DOTC) > Fuel Delivery and Evaporation Lines

INSPECTION

1. Check that the fuel pipe has no deformation, cracks or other damages.
2. Check that the hose and tube have no cracks, damage or loose part.

FUEL INJECTION (FUEL SYSTEMS)(H4DOTC) > Symptoms and causes

INSPECTION

Symptoms	Problem parts etc.	Possible cause	
Insufficient fuel supply	Fuel pump fuse	Blown-out fuse	
	Fuel pump relay	Faulty relay operation	
	Fuel pump		Faulty pump operation
			Poor contact of connector
	Fuel filter	Clogging of filter	
	Fuel injector	Clogging or malfunction of fuel injector	
	Fuel line pipe, hose or tube	Clogging or deformation of pipe, hose or tube	
	Pressure regulator	Seized or damaged diaphragm	
Air in the fuel system	Fuel percolation or excessive fuel shortage in tank		
Fuel leakage	Fuel pump assembly	Defective gasket or improper installation of fuel pump assembly	
	Fuel sub level sensor	Defective gasket or improper installation	
	Fuel line pipe, hose and tube	Hole, cracking or improper installation of pipe, hose or tube	
	Fuel tank	Hole, cracking in tank	
Gasoline smell inside of compartment	Fuel line pipe, hose and tube	Hole, cracking or improper installation of pipe, hose or tube	
	Service hole cover	Deformed cover, defective gasket or improper installation Caution: Check that no fuel leakage occurs.	
	Saucer COMPL	Damage or improper installation of saucer	
Defective fuel gauge display	Fuel level sensor or fuel sub level sensor	Poor contact at resistance part	
		Seized or deformed arm	
		Deformed or damaged float	
		Connector connection is improper.	
Combination meter	Defective combination meter		
Noise	Fuel pump	Defective pump or improper installation	

Note:

- **Water generated in the fuel tank may be frozen at cold condition. It is preferable to keep the tank full with fuel if possible and to use a water removing agent or anti-freeze agent, etc. if necessary.**
- **If a water removing agent or anti-freeze agent, etc. is used, follow the instruction for use.**