

1. Supplemental Restraint System "Airbag"

Airbag system wiring harness is routed near the ABS/TCS control module, ABS sensor and hydraulic control unit.

CAUTION:

- All Airbag system wiring harness and connectors are colored yellow. Do not use electrical test equipment on these circuit.
- Be careful not to damage Airbag system wiring harness when servicing the ABS/TCS control module, ABS sensor and hydraulic control unit.

2. Pre-inspection

Before performing diagnostics, check the following items which might affect ABS/TCS problems:

A: MECHANICAL INSPECTION

1. POWER SUPPLY

1) Measure battery voltage and specific gravity of electrolyte.

Standard voltage: 12 V, or more

Specific gravity: Above 1.260

2) Check the condition of the main and other fuses, and harnesses and connectors. Also check for proper grounding.

2. BRAKE FLUID

- 1) Check brake fluid level.
- 2) Check brake fluid leakage.

3. BRAKE DRAG

Check brake drag. <Ref. to 4-4 [K100].>

4. BRAKE PAD AND ROTOR

Check brake pad and rotor. <Ref. to 4-4 [K100].>

5. TIRE SPECIFICATIONS, TIRE WEAR AND AIR PRESSURE

Check tire specifications, tire wear and air pressure. <Ref. to 4-2 [S1A0].>

B: ELECTRICAL INSPECTION

1. WARNING LAMP ILLUMINATION PATTERN

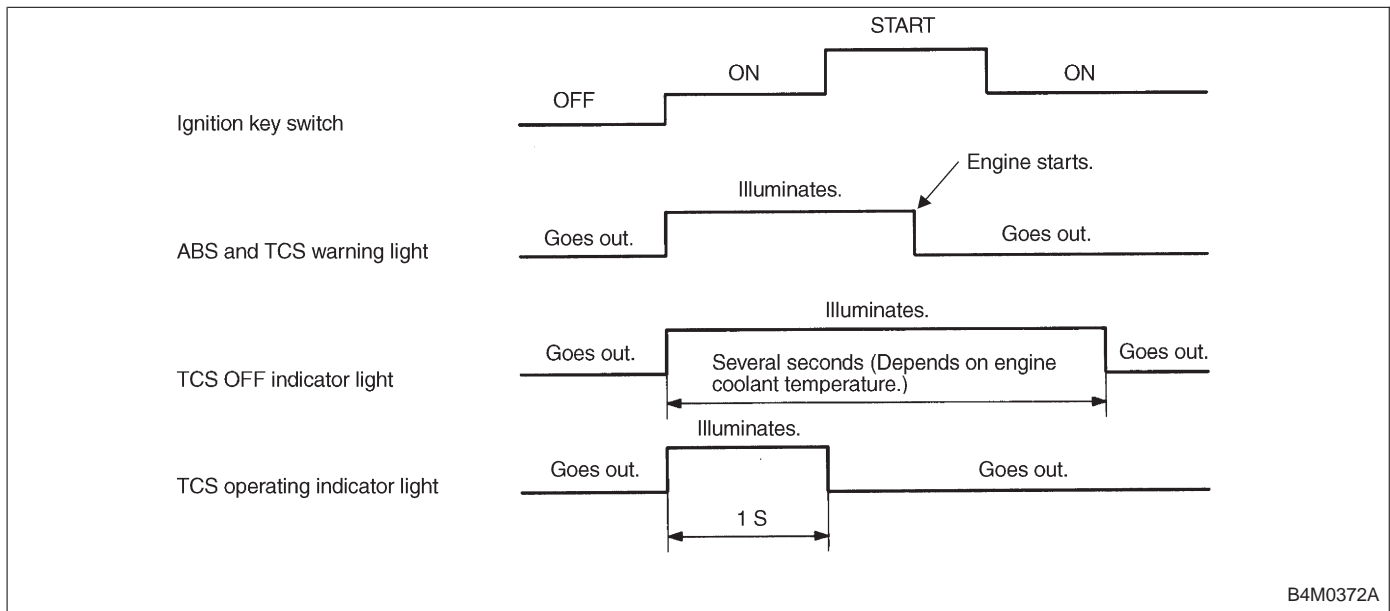

B4M0372A

2. DISPLAY SYSTEM TYPE AND LIGHTING CONDITIONS

○: Illuminated

Mode	ABS warning	TCS warning	TCS OFF	TCS operating	Lighting conditions
Bulb check	○	○			Illuminated with IGN. ON, extinguished with E/G RUN
			○		Illuminated with IGN. ON, extinguished after a few seconds.
				○	Illuminated with IGN. ON, extinguished after 1 second.
ABS failure	○	○			Illuminated during ABS failure (ABS and TCS functions stop)
TCS failure		○			Illuminated during TCS failure (Only TCS functions stop)
TCS OFF			○		Illuminated when TCS operation is prohibited by E/G (low temperature, high temperature, etc.); illuminated during TCS OFF conditions resulting from operation of TCS OFF SW.
TCS operation				○	Illuminated during TCS operation
Pad temperature warning			○		Illuminated when pad temperature reaches 400°C (752°F) or more when TCS is functioning, and extinguished when temperature drops below 350°C (662°F).