

1. General

1. GENERAL DESCRIPTION

- The on-board diagnostics (OBD) system detects and indicates a fault in various inputs and outputs of the complex electronic control. CHECK ENGINE malfunction indicator lamp (MIL) in the combination meter indicates occurrence of a fault or trouble.
- Further, against such a failure or sensors as may disable the drive, the fail-safe function is provided to ensure the minimal driveability.
- The OBD system incorporated with the vehicles within this engine family complies with Section 1968.1, California Code of Regulations (OBD-II regulation). The OBD system monitors the components and the system malfunction listed in Engine Section which affects on emissions.
- When the system decides that a malfunction occurs, MIL illuminates. At the same time of the MIL illumination or blinking, a diagnostic trouble code (DTC) and a freeze frame engine conditions are stored into on-board computer.
- The OBD system stores freeze frame engine condition data (engine load, engine coolant temperature, fuel trim, engine speed and vehicle speed, etc.) into on-board computer when it detects a malfunction first.
- If the OBD system detects the various malfunctions including the fault of fuel trim or misfire, the OBD system first stores freeze frame engine conditions about the fuel trim or misfire.
- When the malfunction does not occur again for three trips, MIL is turned off, but DTC remains at on-board computer.
- The OBD-II system is capable of communication with a general scan tool (OBD-II general scan tool) formed by ISO 9141 CARB.
- The OBD-II diagnostics procedure is different from the usual diagnostics procedure. When troubleshooting OBD-II vehicles, connect Subaru select monitor or the OBD-II general scan tool to the vehicle.

A: ENGINE

1. ENGINE AND EMISSION CONTROL SYSTEM

- The Multipoint Fuel Injection (MFI) system is a system that supplies the optimum air-fuel mixture to the engine for all the various operating conditions through the use of the latest electronic technology.

With this system fuel, which is pressurized at a constant pressure, is injected into the intake air passage of the cylinder head. The injection quantity of fuel is controlled by an intermittent injection system where the electro-magnetic injection valve (fuel injector) opens only for a short period of time, depending on the quantity of air required for one cycle of operation. In actual operation, the injection quan-

tity is determined by the duration of an electric pulse applied to the fuel injector and this permits simple, yet highly precise metering of the fuel.

- Further, all the operating conditions of the engine are converted into electric signals, and this results in additional features of the system, such as large improved adaptability, easier addition of compensating element, etc.

The MFI system also has the following features:

- 1) Reduced emission of harmful exhaust gases.
- 2) Reduced in fuel consumption.
- 3) Increased engine output.
- 4) Superior acceleration and deceleration.
- 5) Superior startability and warm-up performance in cold weather since compensation is made for coolant and intake air temperature.

2. SCHEMATIC

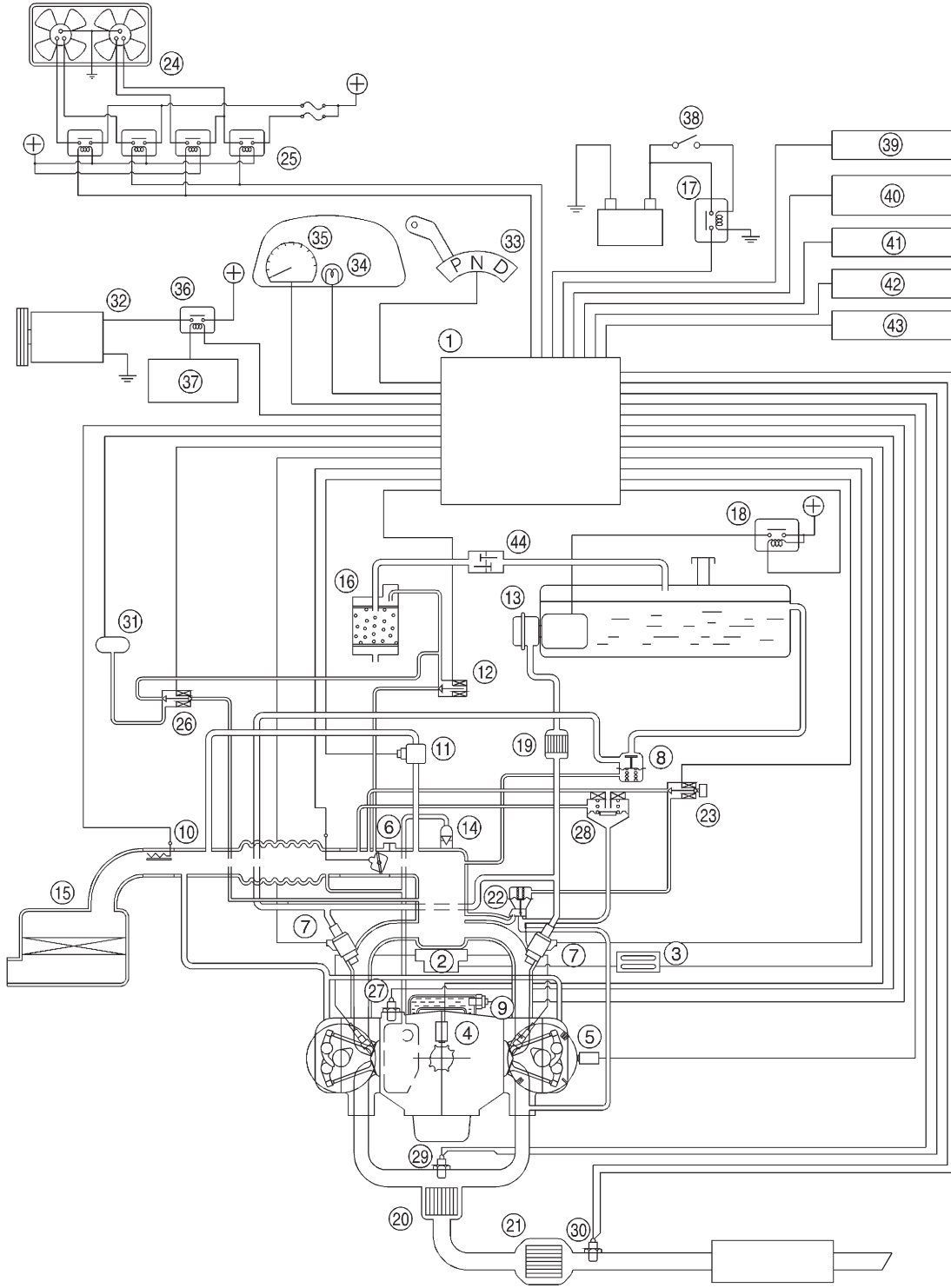

OBD0001A

- ① Engine control module (ECM)
- ② Ignition coil
- ③ Ignitor
- ④ Crankshaft position sensor
- ⑤ Camshaft position sensor
- ⑥ Throttle position sensor
- ⑦ Fuel injectors
- ⑧ Pressure regulator
- ⑨ Engine coolant temperature sensor
- ⑩ Mass air flow sensor
- ⑪ Idle air control solenoid valve
- ⑫ Purge control solenoid valve
- ⑬ Fuel pump
- ⑭ PCV valve
- ⑮ Air cleaner
- ⑯ Canister
- ⑰ Main relay
- ⑱ Fuel pump relay
- ⑲ Fuel filter
- ⑳ Front catalytic converter
- ㉑ Rear catalytic converter
- ㉒ EGR valve
- ㉓ EGR control solenoid valve
- ㉔ Radiator fan
- ㉕ Radiator fan relay
- ㉖ Pressure sources switching solenoid valve (AT vehicles only)
- ㉗ Knock sensor
- ㉘ Back-pressure transducer (AT vehicles only)
- ㉙ Front oxygen sensor
- ㉚ Rear oxygen sensor
- ㉛ Pressure sensor (AT vehicles only)
- ㉜ A/C compressor
- ㉝ Inhibitor switch
- ㉞ CHECK ENGINE malfunction indicator lamp (MIL)
- ㉟ Tachometer
- ㊱ A/C relay
- ㊲ A/C control module
- ㊳ Ignition switch
- ㊴ Transmission control module (TCM) (AT vehicles only)
- ㊵ ABS/TCS control module (TCS equipped models)
- ㊶ Vehicle speed sensor
- ㊷ Data link connector (Subaru select monitor)
- ㊸ Data link connector (OBD-II general scan tool)
- ㊹ Two way valve

B: AUTOMATIC TRANSMISSION**1. ELECTRONIC-HYDRAULIC CONTROL SYSTEM**

The electronic-hydraulic control system consists of various sensors and switches, a transmission control module (TCM) and the hydraulic controller including solenoid valves. The system controls the transmission proper including shift control, lock-up control, overrunning clutch control, line pressure control and shift timing control. It also controls the AWD transfer clutch. In other words, the system detects various operating conditions from various input signals and sends output signals to shift solenoids 1, 2 and 3 and duty solenoids A, B and C (a total of six solenoids).

2. SCHEMATIC

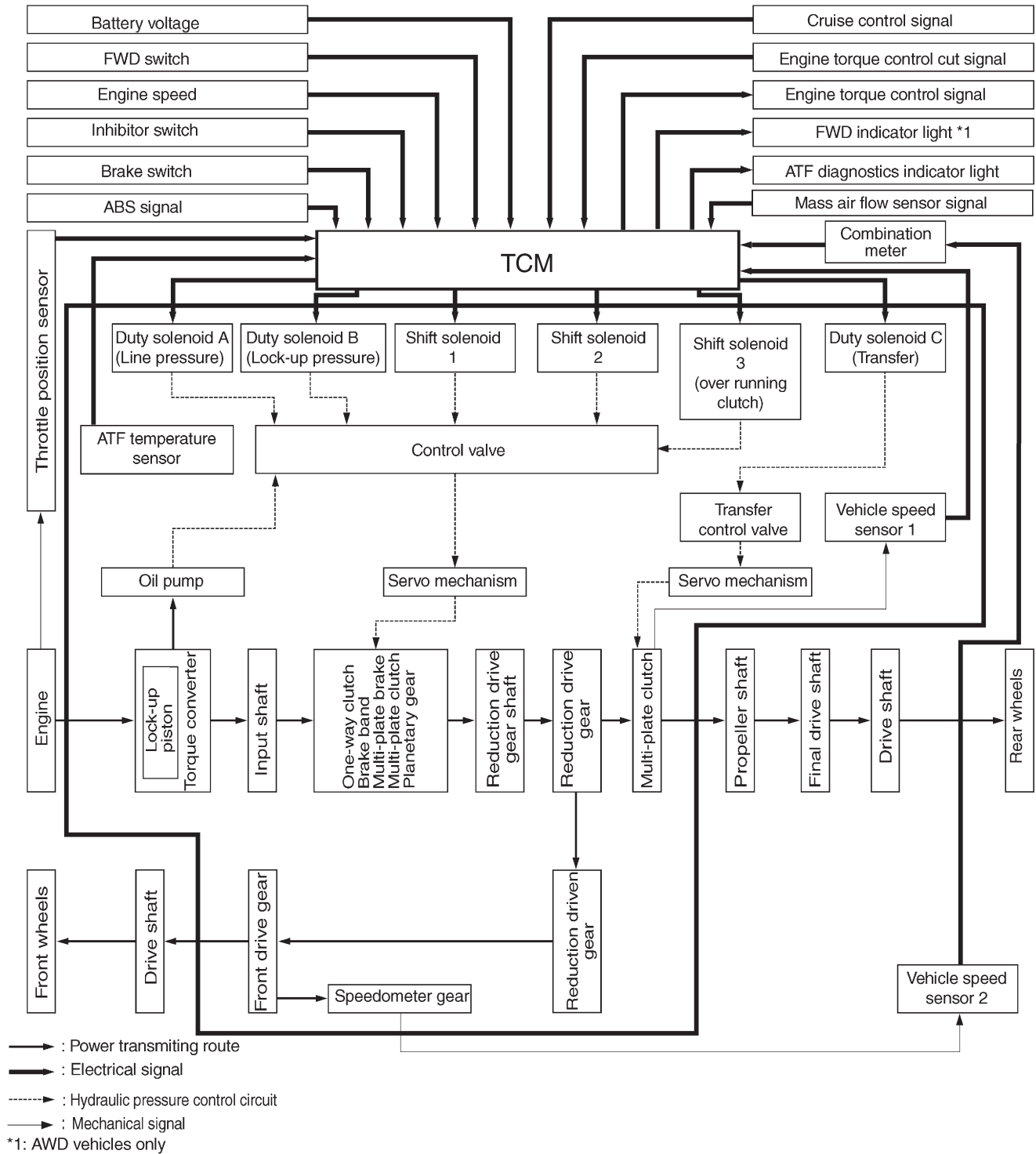

B2M0619A