

1. Supplemental Restraint System "Airbag"

1. Supplemental Restraint System "Airbag"

Airbag system wiring harness is routed on and along body panels.

CAUTION:

- All Airbag system wiring harness and connectors are colored yellow. Do not use electrical test equipment on these circuits.
- Be careful not to damage Airbag system wiring harness when repairing the body panel.

A: ENGINE COMPARTMENT AND ROOM

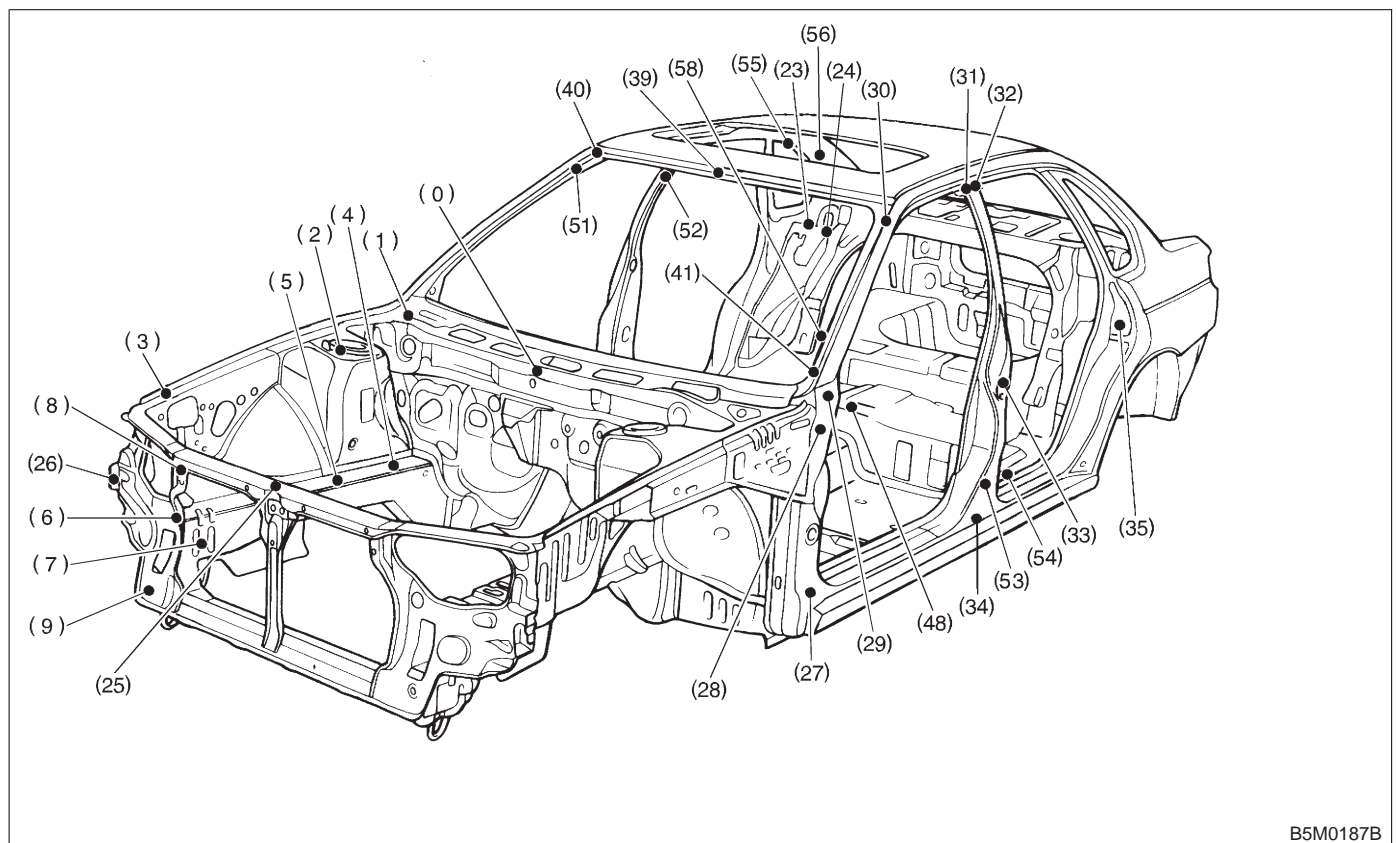

B5M0187B

- | | | |
|---|---|---|
| (0) Cowl panel weather attaching hole 6 mm (0.24 in) dia. | (7) Side frame of front side frame 12 mm (0.47 in) dia. | (27) Front fender attaching hole at front pillar lower portion M6 |
| (1) Hood hinge front attaching hole M8 | (8) Headlight attaching hole at radiator side panel 6.2 × 9 mm (0.244 × 0.35 in) dia. | (28) Hinge middle hole at front pillar center 10 mm (0.39 in) dia. |
| (2) Strut mount attaching hole (Front center) 9.5 mm (0.374 in) dia. | (9) Radiator panel side (LWR) gauge hole 23 mm (0.91 in) dia. | (29) Front fender attaching hole at front pillar center portion M6 |
| (3) Front fender attaching hole (Tip) M6 | (23) Rear strut mount attaching hole (Side) 10 mm (0.39 in) dia. | (30) Retainer attaching square hole at front pillar 7 × 7 mm (0.28 × 0.28 in) |
| (4) Rear upper surface of front side frame 12 mm (0.47 in) dia. | (24) Rear strut mount attaching hole (Center) 12 mm (0.47 in) (0.244 × 0.35 in) dia. | (31) Retainer attaching hole at center pillar (Front) 3.5 mm (0.138 in) dia. |
| (5) Middle upper surface of front side frame 20 mm (0.79 in) dia. | (25) Radiator panel (UPR) middle hole 6 mm (0.24 in) dia. | (32) Retainer attaching hole at center pillar (Rear) 3.5 mm (0.138 in) dia. |
| (6) Front side frame front upper surface 14 × 16 mm (0.55 × 0.63 in) dia. oblong hole | (26) Front fender attaching hole at radiator panel side M6 | |

2. Body Datum Points

Various master repair locations are established as datum points used during body repairs. In addition, guide holes, locators and indents are provided to facilitate panel replacement and achieve alignment accuracy.

NOTE:

Left and right datum points are all symmetrical to each other.

1. Supplemental Restraint System "Airbag"

1. Supplemental Restraint System "Airbag"

Airbag system wiring harness is routed on and along body panels.

CAUTION:

- All Airbag system wiring harness and connectors are colored yellow. Do not use electrical test equipment on these circuits.
- Be careful not to damage Airbag system wiring harness when repairing the body panel.

A: ENGINE COMPARTMENT AND ROOM

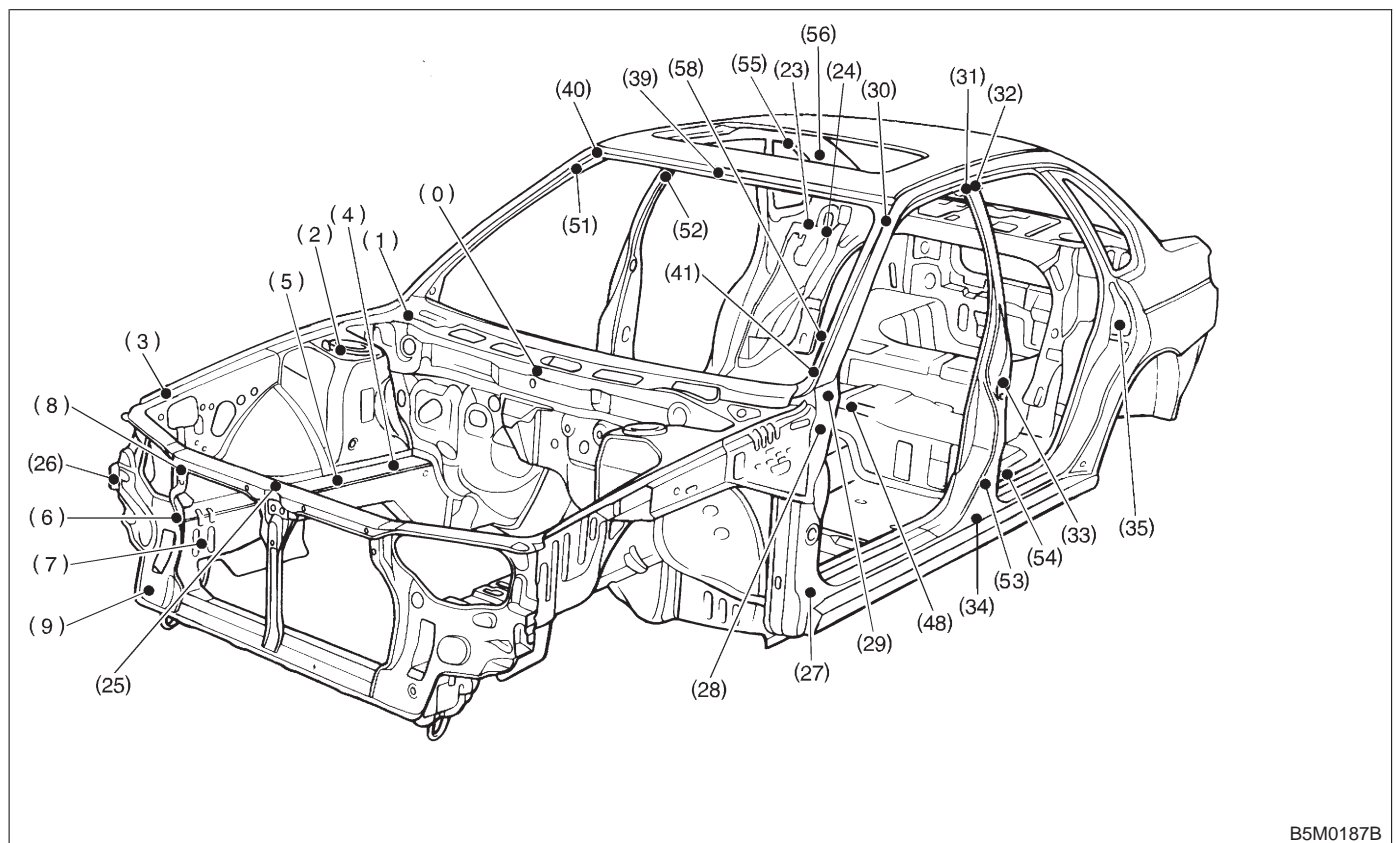

B5M0187B

- | | | |
|---|---|---|
| (0) Cowl panel weather attaching hole 6 mm (0.24 in) dia. | (7) Side frame of front side frame 12 mm (0.47 in) dia. | (27) Front fender attaching hole at front pillar lower portion M6 |
| (1) Hood hinge front attaching hole M8 | (8) Headlight attaching hole at radiator side panel 6.2 × 9 mm (0.244 × 0.35 in) dia. | (28) Hinge middle hole at front pillar center 10 mm (0.39 in) dia. |
| (2) Strut mount attaching hole (Front center) 9.5 mm (0.374 in) dia. | (9) Radiator panel side (LWR) gauge hole 23 mm (0.91 in) dia. | (29) Front fender attaching hole at front pillar center portion M6 |
| (3) Front fender attaching hole (Tip) M6 | (23) Rear strut mount attaching hole (Side) 10 mm (0.39 in) dia. | (30) Retainer attaching square hole at front pillar 7 × 7 mm (0.28 × 0.28 in) |
| (4) Rear upper surface of front side frame 12 mm (0.47 in) dia. | (24) Rear strut mount attaching hole (Center) 12 mm (0.47 in) (0.244 × 0.35 in) dia. | (31) Retainer attaching hole at center pillar (Front) 3.5 mm (0.138 in) dia. |
| (5) Middle upper surface of front side frame 20 mm (0.79 in) dia. | (25) Radiator panel (UPR) middle hole 6 mm (0.24 in) dia. | (32) Retainer attaching hole at center pillar (Rear) 3.5 mm (0.138 in) dia. |
| (6) Front side frame front upper surface 14 × 16 mm (0.55 × 0.63 in) dia. oblong hole | (26) Front fender attaching hole at radiator panel side M6 | |

2. Body Datum Points

Various master repair locations are established as datum points used during body repairs. In addition, guide holes, locators and indents are provided to facilitate panel replacement and achieve alignment accuracy.

NOTE:

Left and right datum points are all symmetrical to each other.

- | | | |
|--|---|--|
| (33) Lower side of rear door hinge M8 | (41) Stud bolt lower locating notch | (55) Trim upper attaching hole at 6 light 8 mm (0.31 in) dia. |
| (34) Center pillar (LWR) gauge hole 27 mm (1.06 in) dia. | (48) Front center of rear floor pan 8 mm (0.31 in) dia. | (56) Trim lower attaching hole at 6 light 8 mm (0.31 in) dia. |
| (35) Rear quarter outer corner patch attaching hole 5.2 mm (0.205 in) dia. | (51) Front upper pillar (Inner) 7 mm (0.28 in) dia. | (58) Rear floor, near floor strut 15 × 20 mm (0.59 × 0.79 in) dia. oblong hole |
| (39) Front rail center notch | (52) Front seat belt adjust plate attaching hole 12 mm (0.47 in) dia. | |
| (40) Front glass upper locating notch RH: 6.5 mm (0.256 in) dia., LH: 6.5 × 10 mm (0.256 × 0.39 in) dia. oblong hole | (53) Rear door hinge middle hole 10 mm (0.39 in) dia. | |
| | (54) Rear floor, near door 8 mm (0.31 in) dia. | |

B: LUGGAGE COMPARTMENT AND ROOM

1. SEDAN

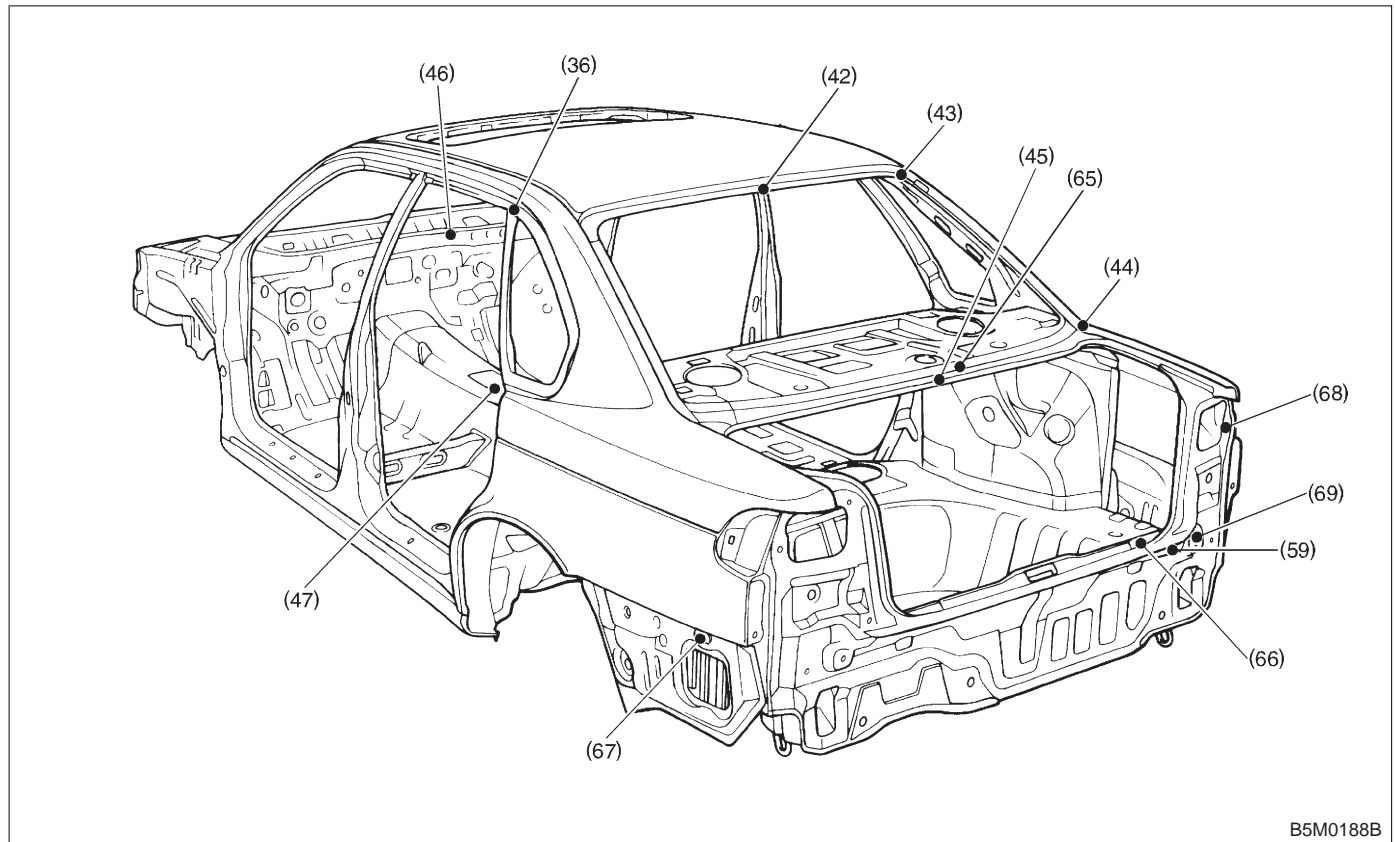

B5M0188B

- | | | |
|--|--|---|
| (36) 6 light upper retainer attaching square hole 7 × 7 mm (0.28 × 0.28 in) | (45) Rear panel drain locator concave part | (67) Rear bumper side attaching hole 6 mm (0.24 in) dia. |
| (42) Rear rail center notch | (46) Front panel gauge hole 10 mm (0.39 in) dia. | (68) Rear combination light mounting hole 8 mm (0.31 in) dia. |
| (43) Rear glass upper locating hole RH: 6.5 mm (0.256 in) dia., LH: 6.5 × 10 mm (0.256 × 0.39 in) dia. oblong hole | (47) Tunnel center M8 | (69) Rear bumper beam attaching hole RH: 8 mm (0.31 in) dia., LH: 8 × 12 mm (0.31 × 0.47 in) dia. oblong hole |
| (44) Rear glass molding attaching square hole 8 × 8 mm (0.31 × 0.31 in) | (49) Rear bumper attaching hole 45 mm (1.77 in) dia. | |
| | (65) Rear wiper attaching hole M6 | |
| | (66) Trim attaching hole at rear skirt (UPR) 7 mm (0.28 in) dia. | |

2. WAGON

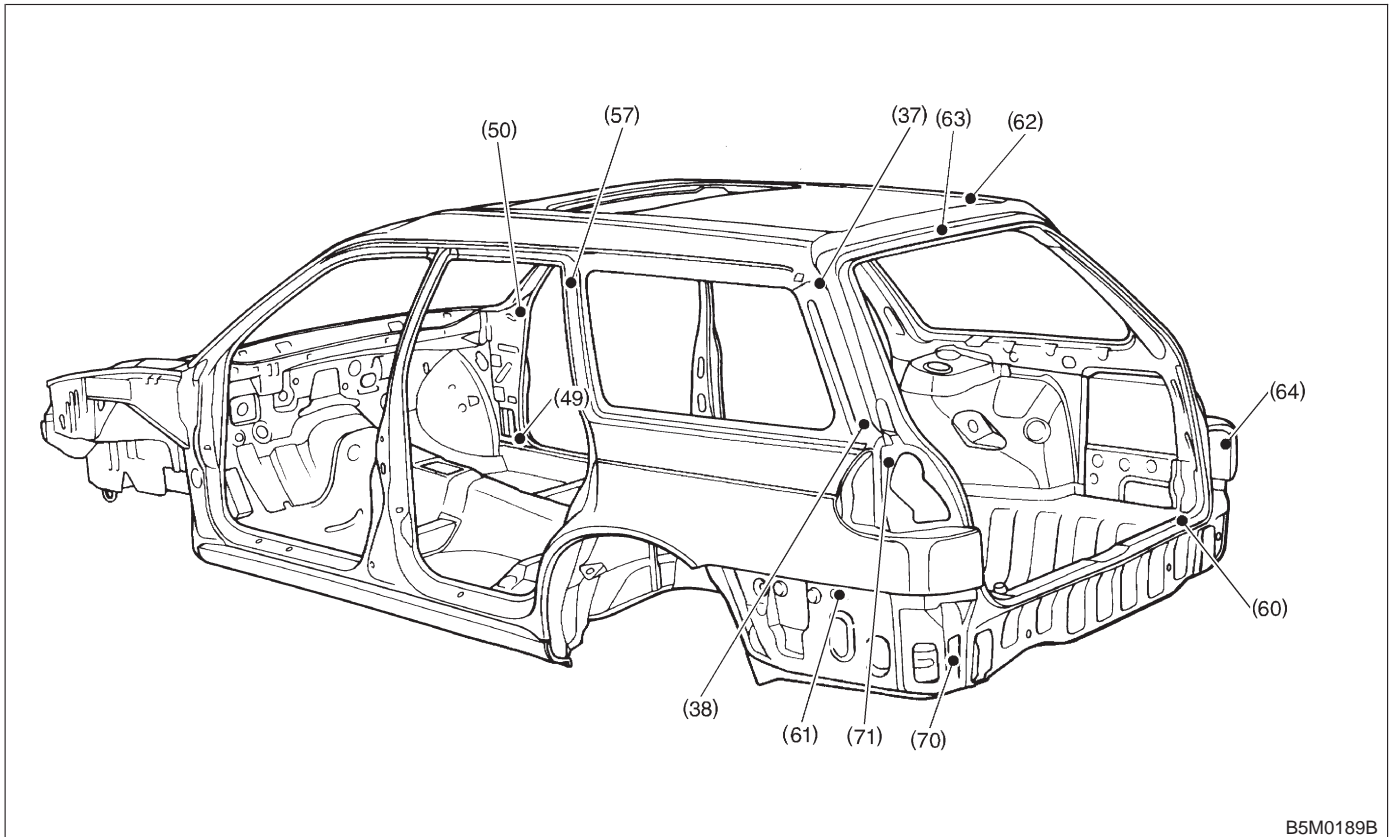

B5M0189B

- | | | |
|---|---|---|
| (37) D pillar cover attaching hole 12 × 8 mm (0.47 × 0.31 in) dia. | (57) Retainer attaching square hole at C pillar (UPR) 7 × 7 mm (0.28 × 0.28 in) | (64) Buffer attaching hole (UPR) M6 |
| (38) Shoulder mole attaching hole 8 mm (0.31 in) dia. | (60) Trim attaching hole at rear skirt (UPR) 15 mm (0.59 in) dia. | (70) Rear quarter end (LWR) gauge hole 20 mm (0.79 in) dia. |
| (49) Front pillar (LWR) gauge hole 10 mm (0.39 in) dia. (On both Sedan and Wagon) | (61) Rear bumper side attaching hole 6 mm (0.24 in) dia. | (71) Rear combination light mounting hole 7 mm (0.28 in) dia. |
| (50) Front pillar (UPR) gauge hole 16 mm (0.63 in) dia. (On both Sedan and Wagon) | (62) Rear seat belt bolt hole 13 mm (0.51 in) dia. | |
| | (63) Rear rail locator concave part | |

C: UNDERBODY

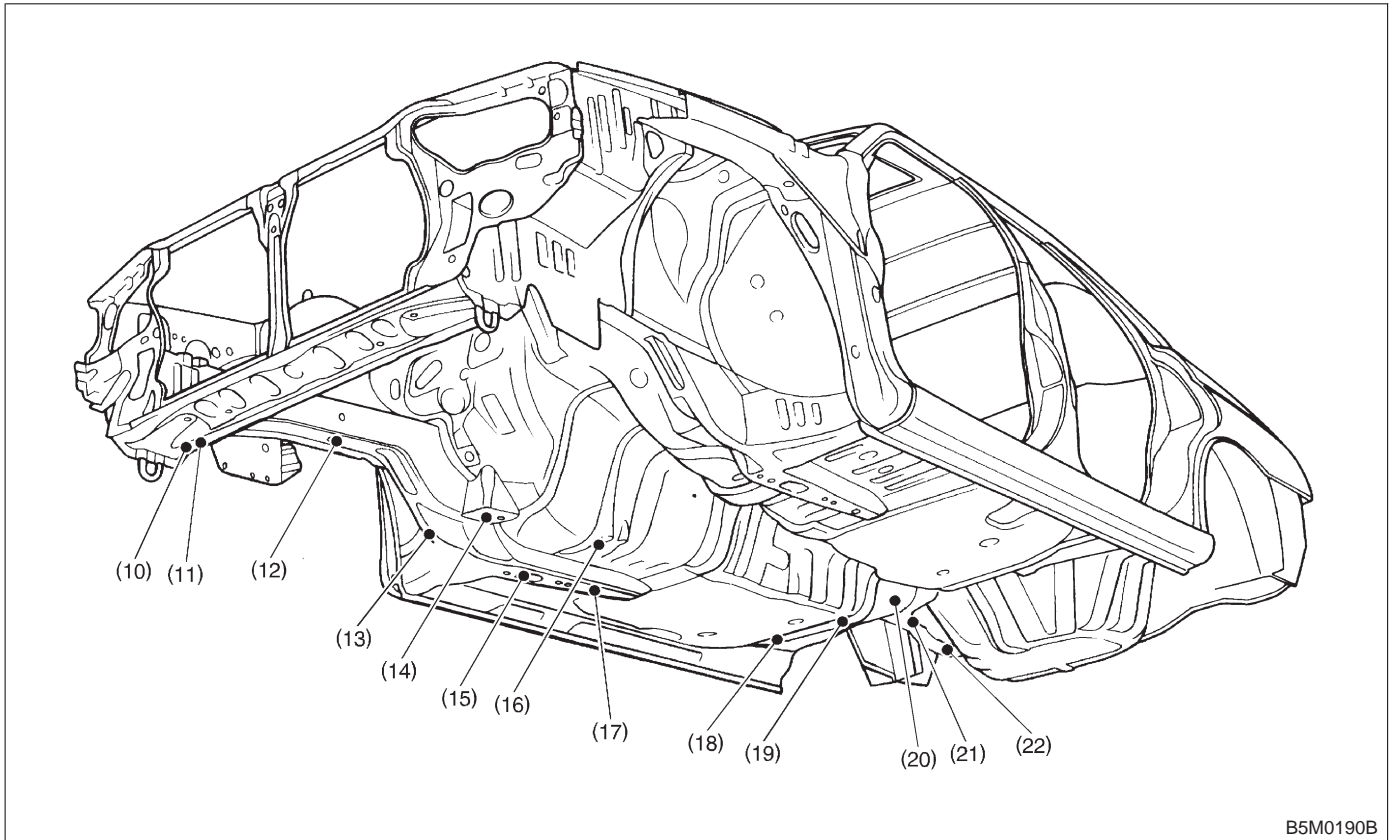

B5M0190B

- | | | |
|---|--|--|
| (10) Radiator panel (LWR) frame gauge hole 10 mm (0.39 in) dia. | (15) Front side frame rear lower center surface 20 mm (0.79 in) dia. | (20) Rear crossmember attaching hole M12 |
| (11) Front side frame front lower surface 20 mm (0.79 in) dia. | (16) Transmission mount attaching hole M10 | (21) Rear frame center hole 7 mm (0.28 in) dia. |
| (12) Front side frame center lower surface 20 mm (0.79 in) dia. | (17) Front side frame rear lower surface 15 mm (0.59 in) dia. | (22) Rear frame rear concave part 15 mm (0.59 in) dia. |
| (13) Front suspension attaching hole M14 | (18) Rear frame front M12 | |
| (14) Suspension attaching bracket M14 | (19) Rear frame front hole 25 mm (0.98 in) dia. | |

D: DATUM POINT LOCATION

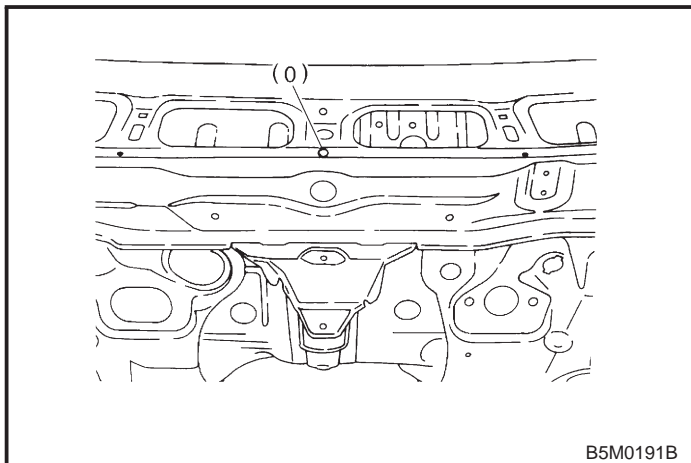

B5M0191B

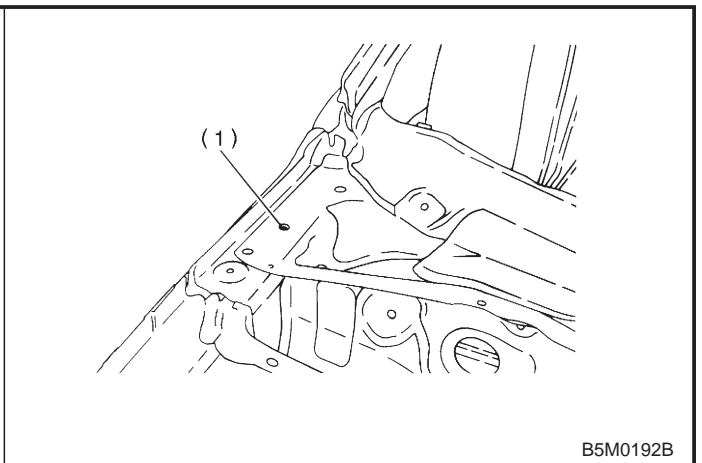

B5M0192B

5-1 [S2D0]
2. Body Datum Points

SPECIFICATIONS AND SERVICE DATA

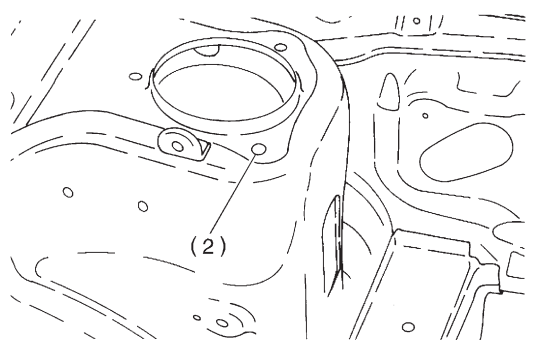
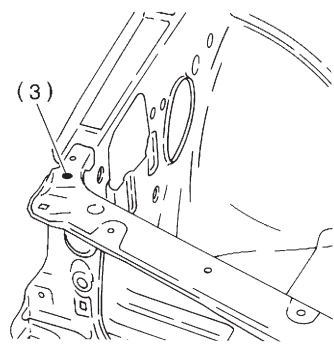
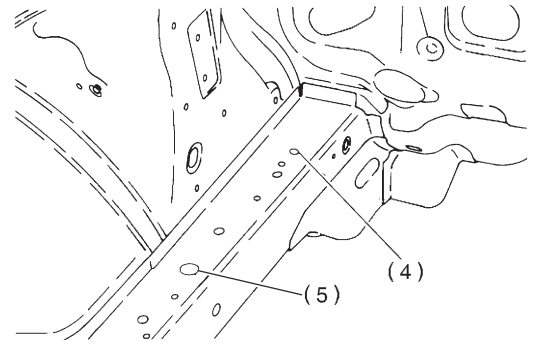
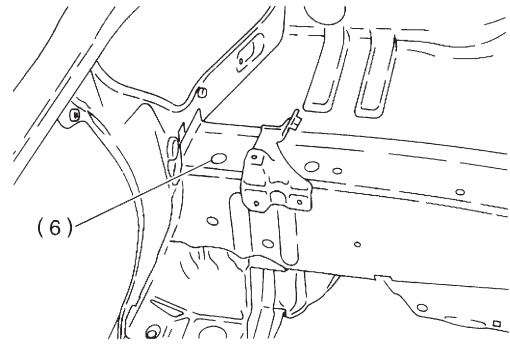
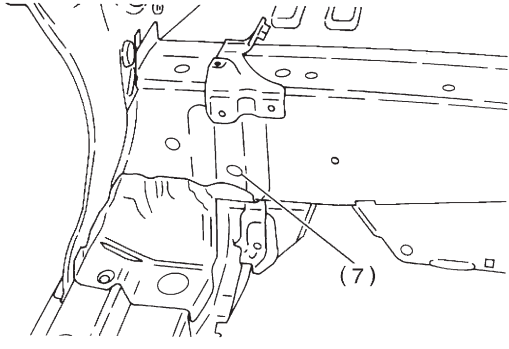
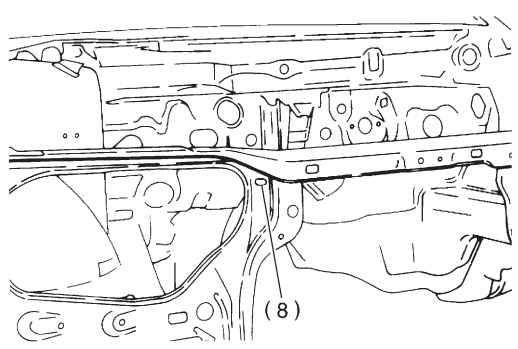
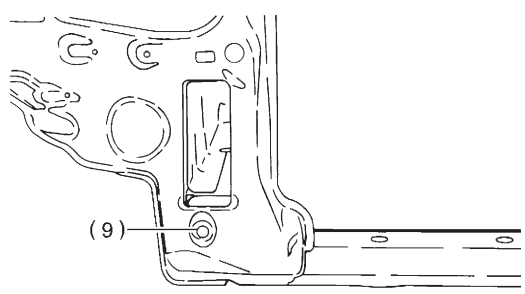
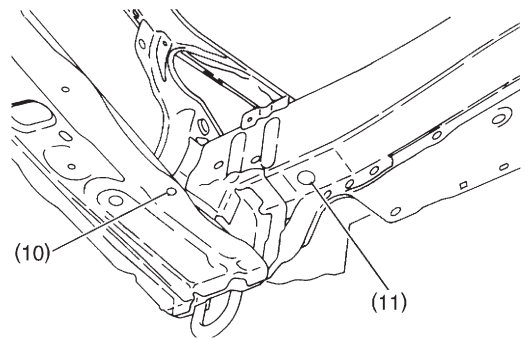
 <p>(2)</p>	 <p>(3)</p>
 <p>(5) (4)</p>	 <p>(6)</p>
 <p>(7)</p>	 <p>(8)</p>
 <p>(9)</p>	 <p>(10) (11)</p>

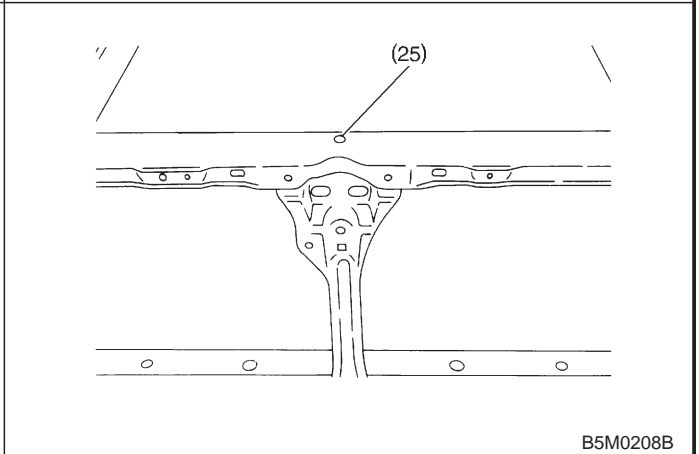
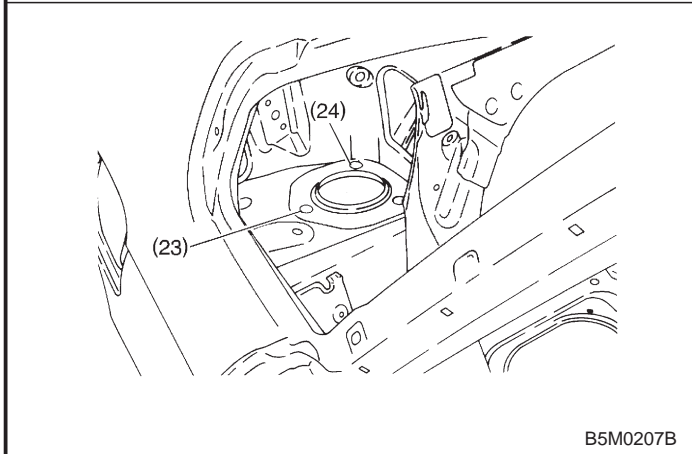
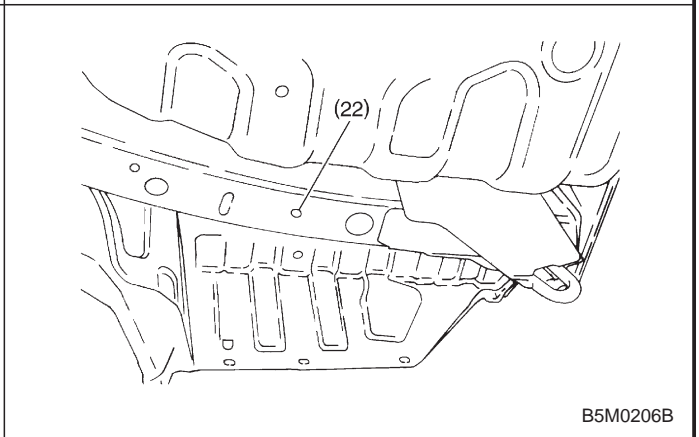
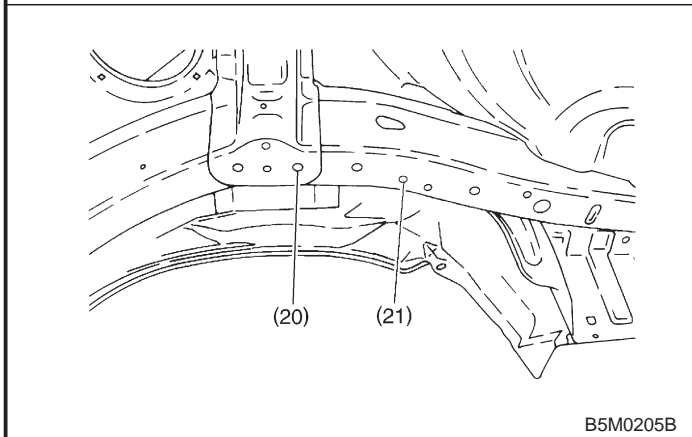
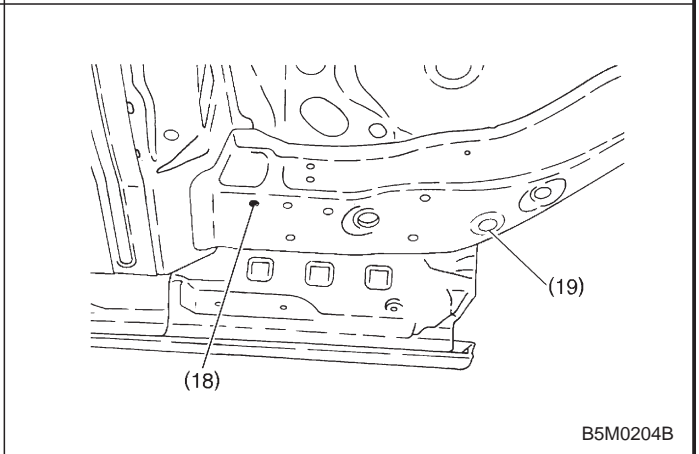
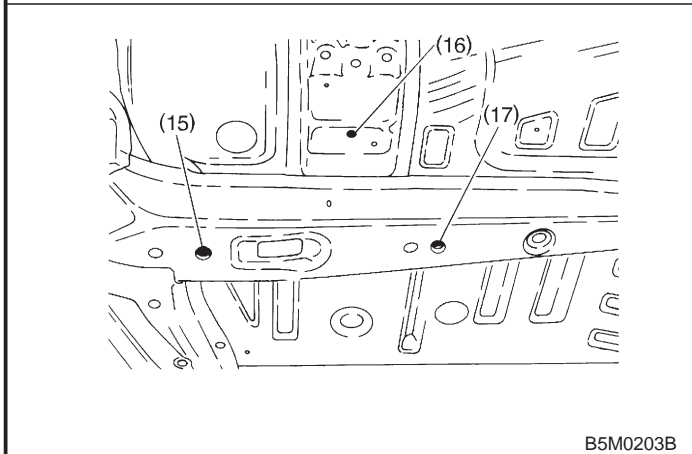
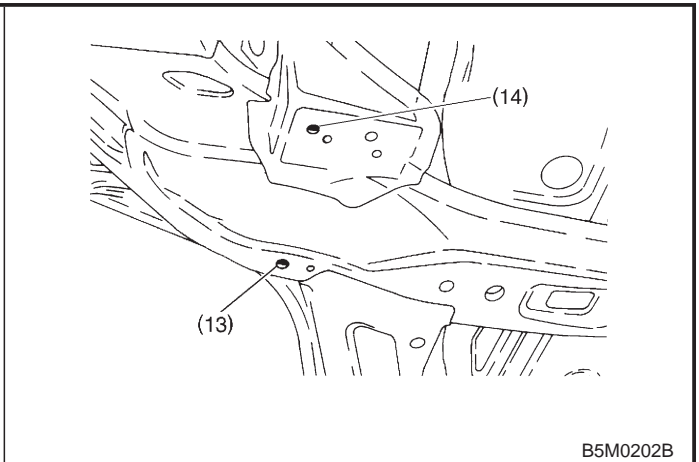
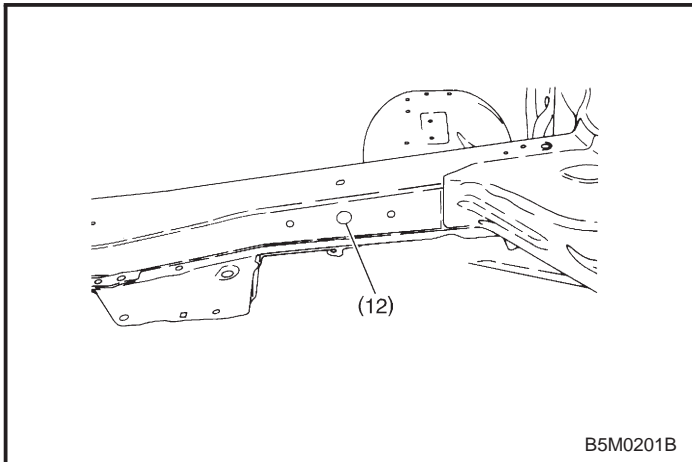

SPECIFICATIONS AND SERVICE DATA

[S2D0] 5-1
2. Body Datum Points



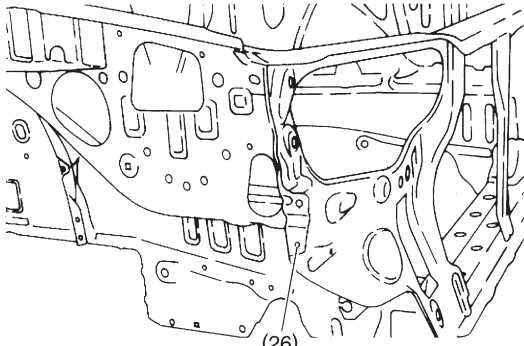
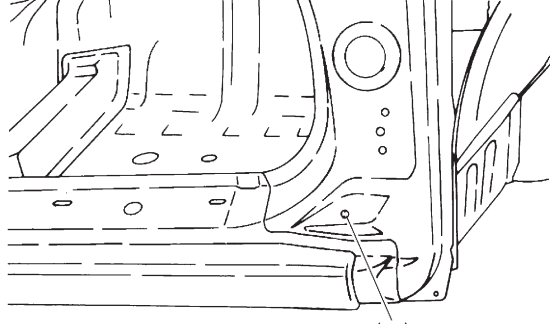

5-1 [S2D0]
2. Body Datum Points

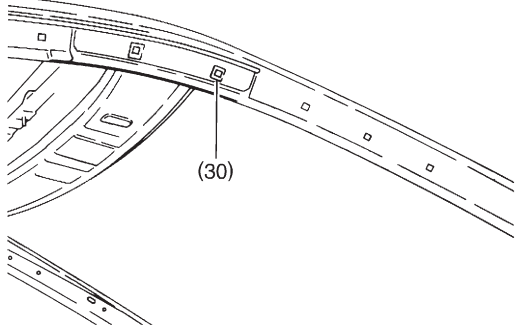
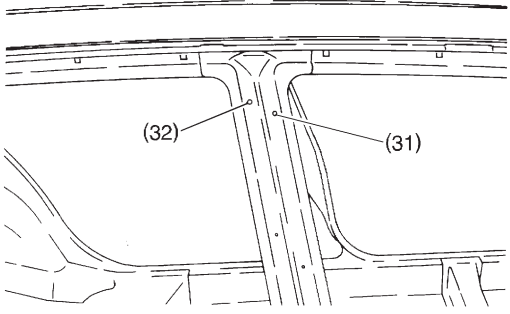
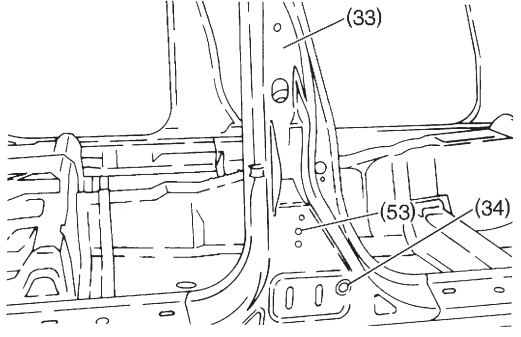
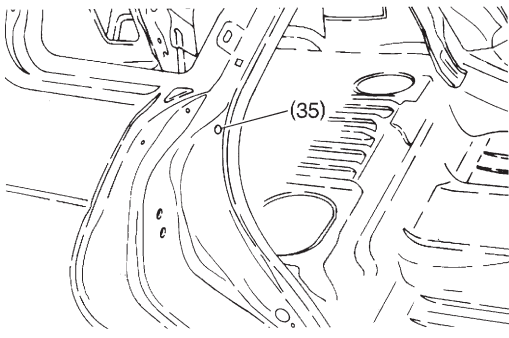
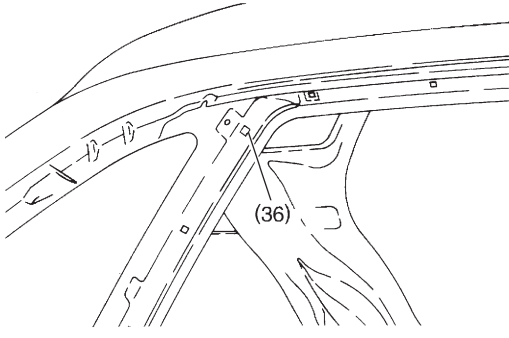
SPECIFICATIONS AND SERVICE DATA

 <p>(26)</p> <p>B5M0209B</p>	 <p>(27)</p> <p>B5M0210B</p>
 <p>(29)</p> <p>(28)</p> <p>B5M0211B</p>	 <p>(30)</p> <p>B5M0212B</p>
 <p>(32)</p> <p>(31)</p> <p>B5M0213B</p>	 <p>(33)</p> <p>(53)</p> <p>(34)</p> <p>B5M0214B</p>
 <p>(35)</p> <p>B5M0215B</p>	 <p>(36)</p> <p>B5M0216B</p>

SPECIFICATIONS AND SERVICE DATA

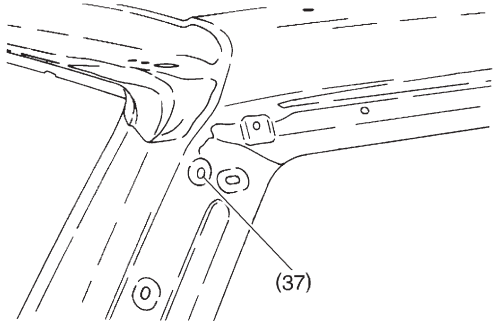
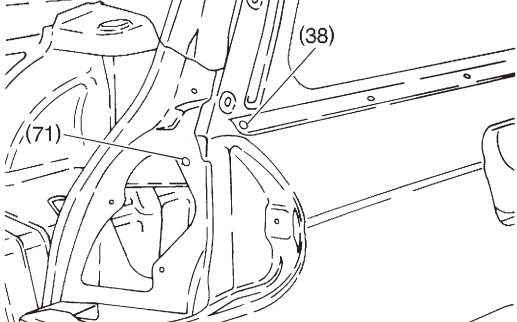
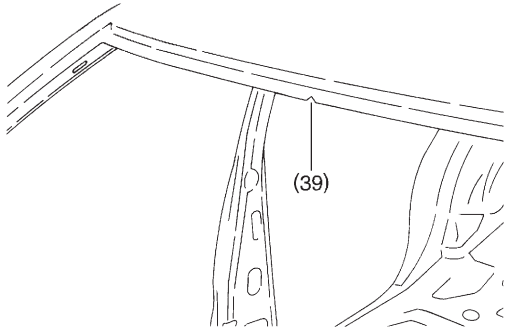
[S2D0] 5-1
2. Body Datum Points

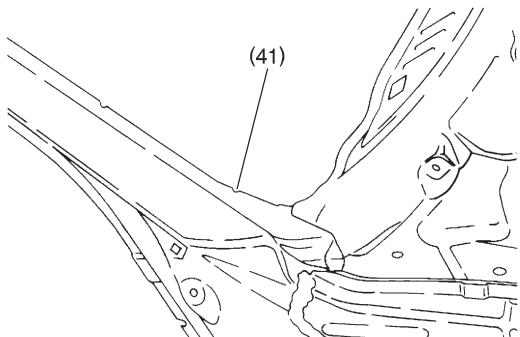
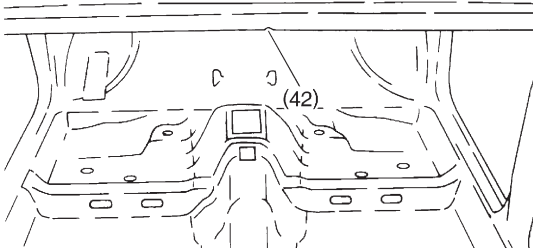
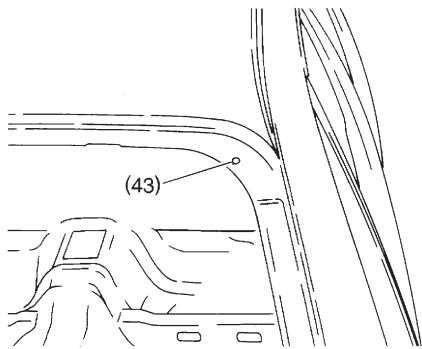
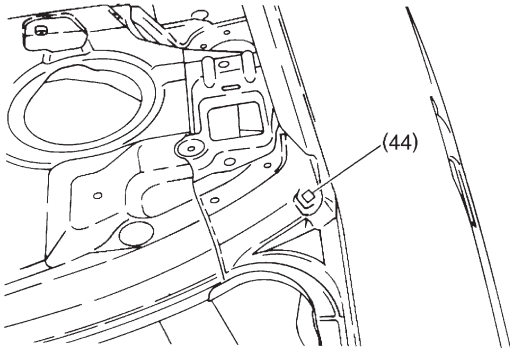
 <p>B5M0217B</p>	 <p>B5M0218B</p>
 <p>B5M0219B</p>	 <p>B5M0220B</p>
 <p>B5M0221B</p>	 <p>B5M0222B</p>
 <p>B5M0223B</p>	 <p>B5M0224B</p>

5-1 [S2D0]
2. Body Datum Points

SPECIFICATIONS AND SERVICE DATA

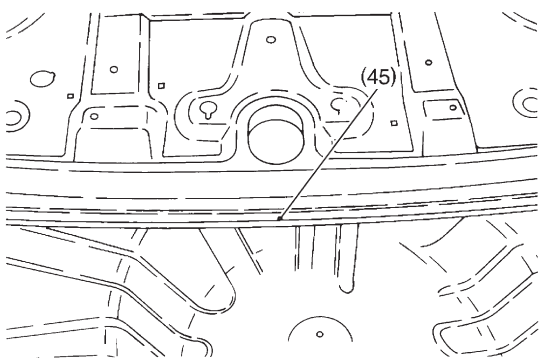
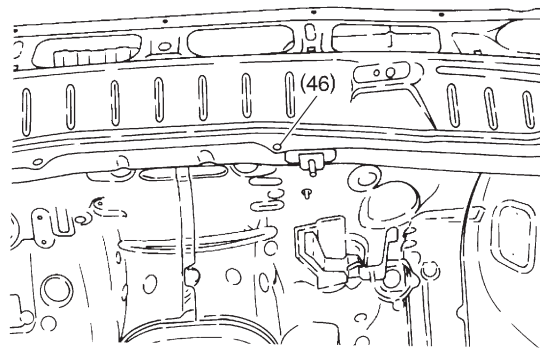
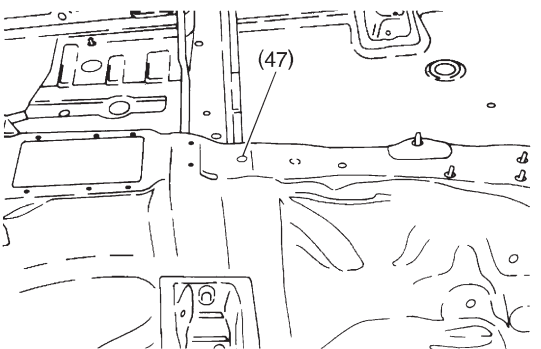
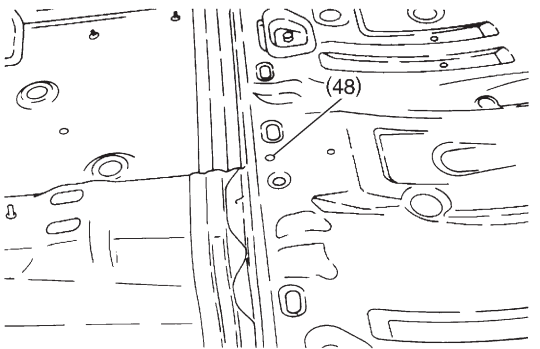
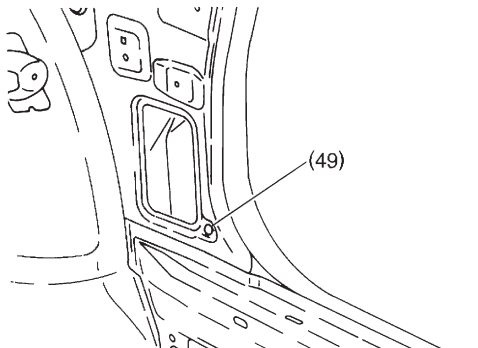
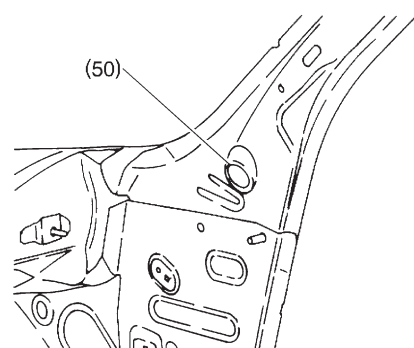
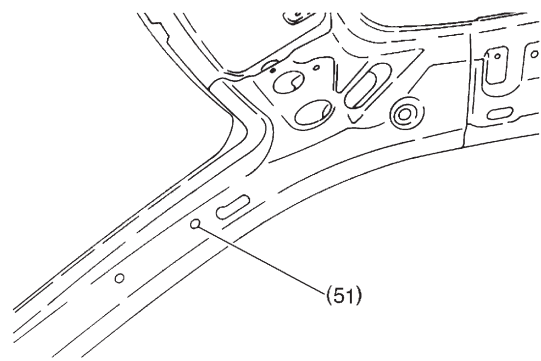
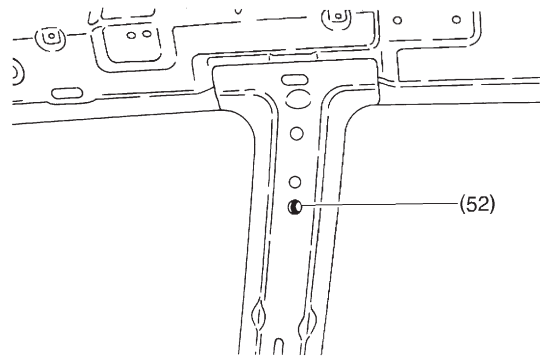
 <p>(45)</p>	 <p>(46)</p>
 <p>(47)</p>	 <p>(48)</p>
 <p>(49)</p>	 <p>(50)</p>
 <p>(51)</p>	 <p>(52)</p>

SPECIFICATIONS AND SERVICE DATA

[S2D0] 5-1
2. Body Datum Points

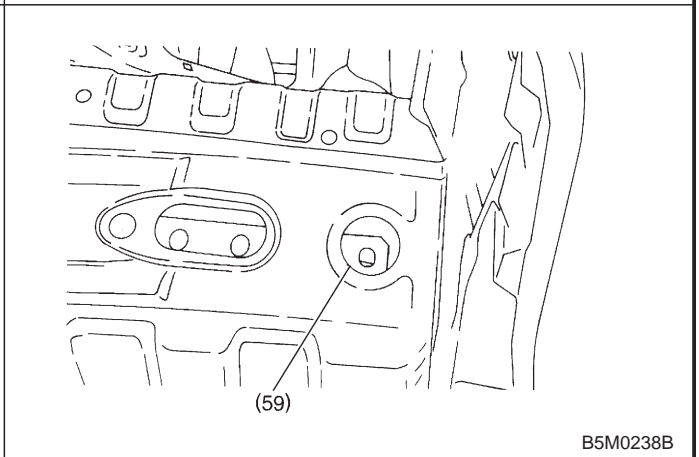
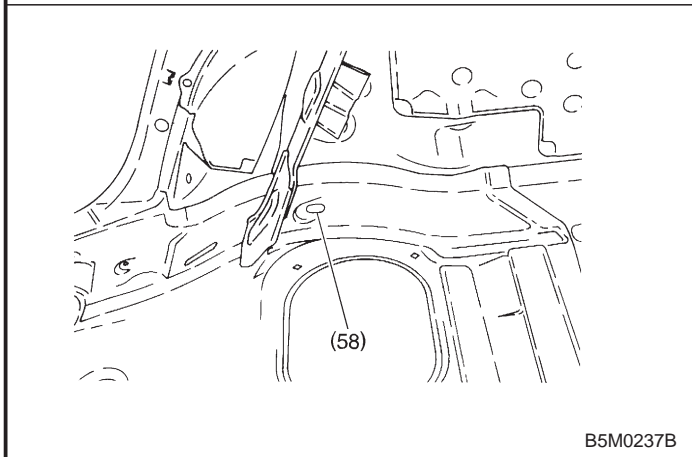
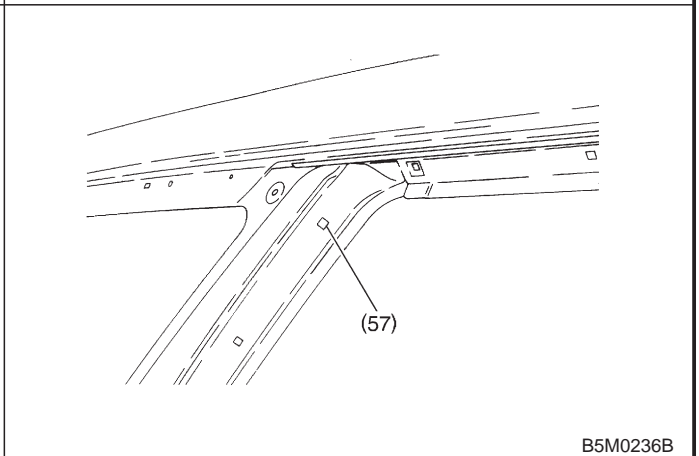
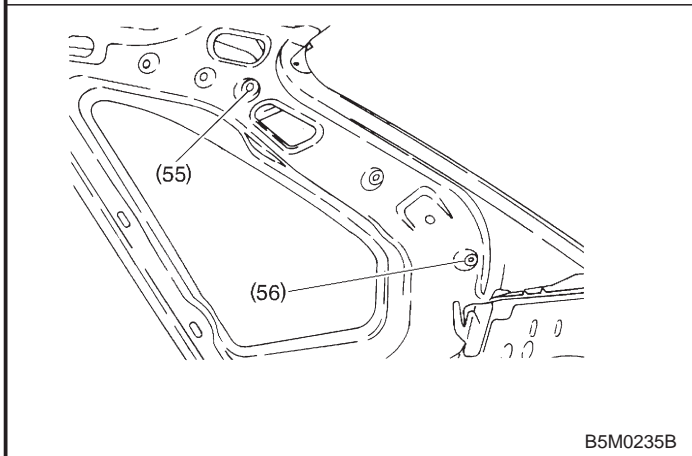
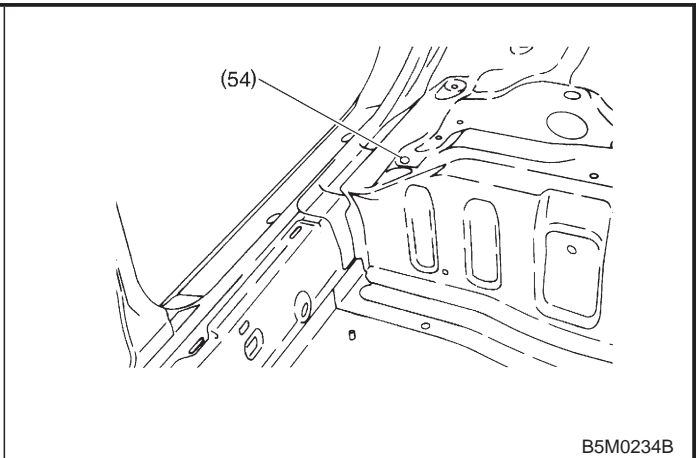
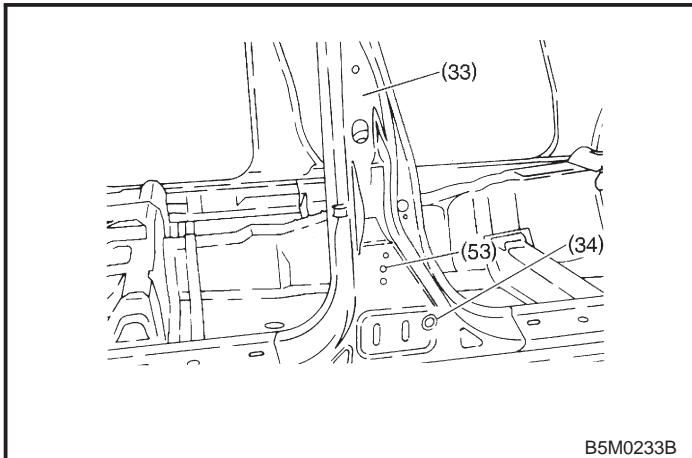

5-1 [S2D0]
2. Body Datum Points

SPECIFICATIONS AND SERVICE DATA

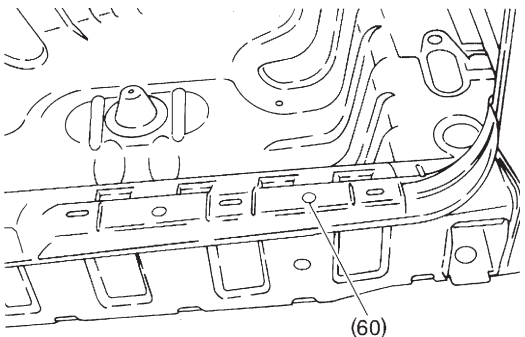
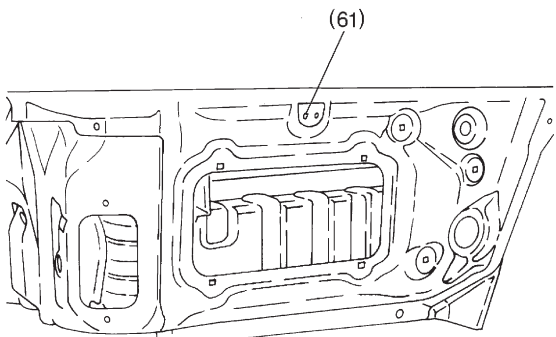
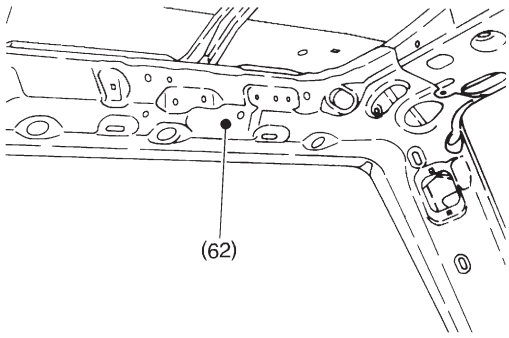
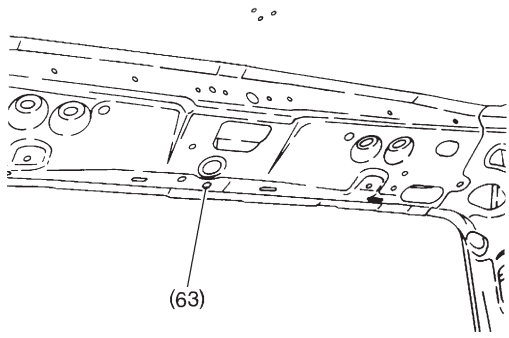
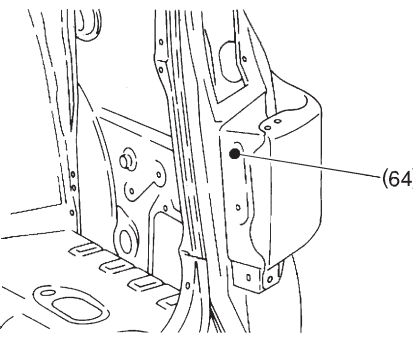
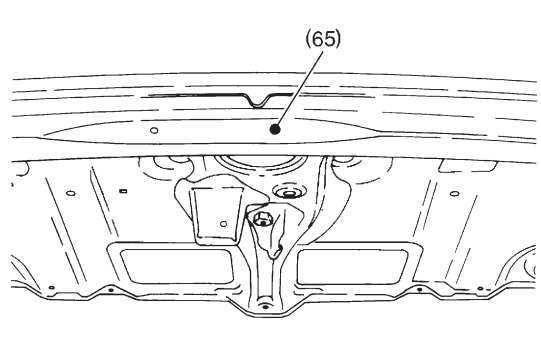
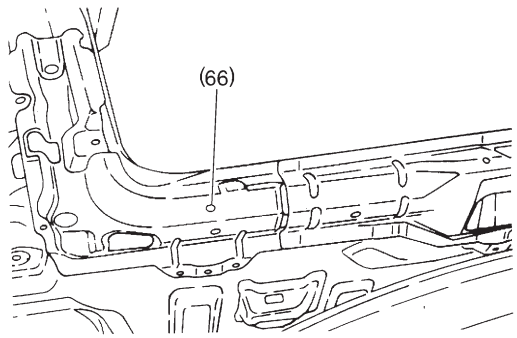
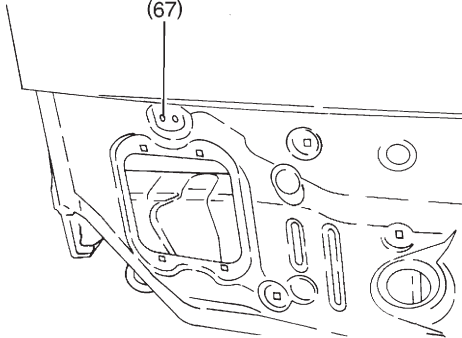
 <p>(60)</p> <p>B5M0239B</p>	 <p>(61)</p> <p>B5M0240B</p>
 <p>(62)</p> <p>B5M0241B</p>	 <p>(63)</p> <p>B5M0242B</p>
 <p>(64)</p> <p>B5M0243B</p>	 <p>(65)</p> <p>B5M0244B</p>
 <p>(66)</p> <p>B5M0245B</p>	 <p>(67)</p> <p>B5M0246B</p>

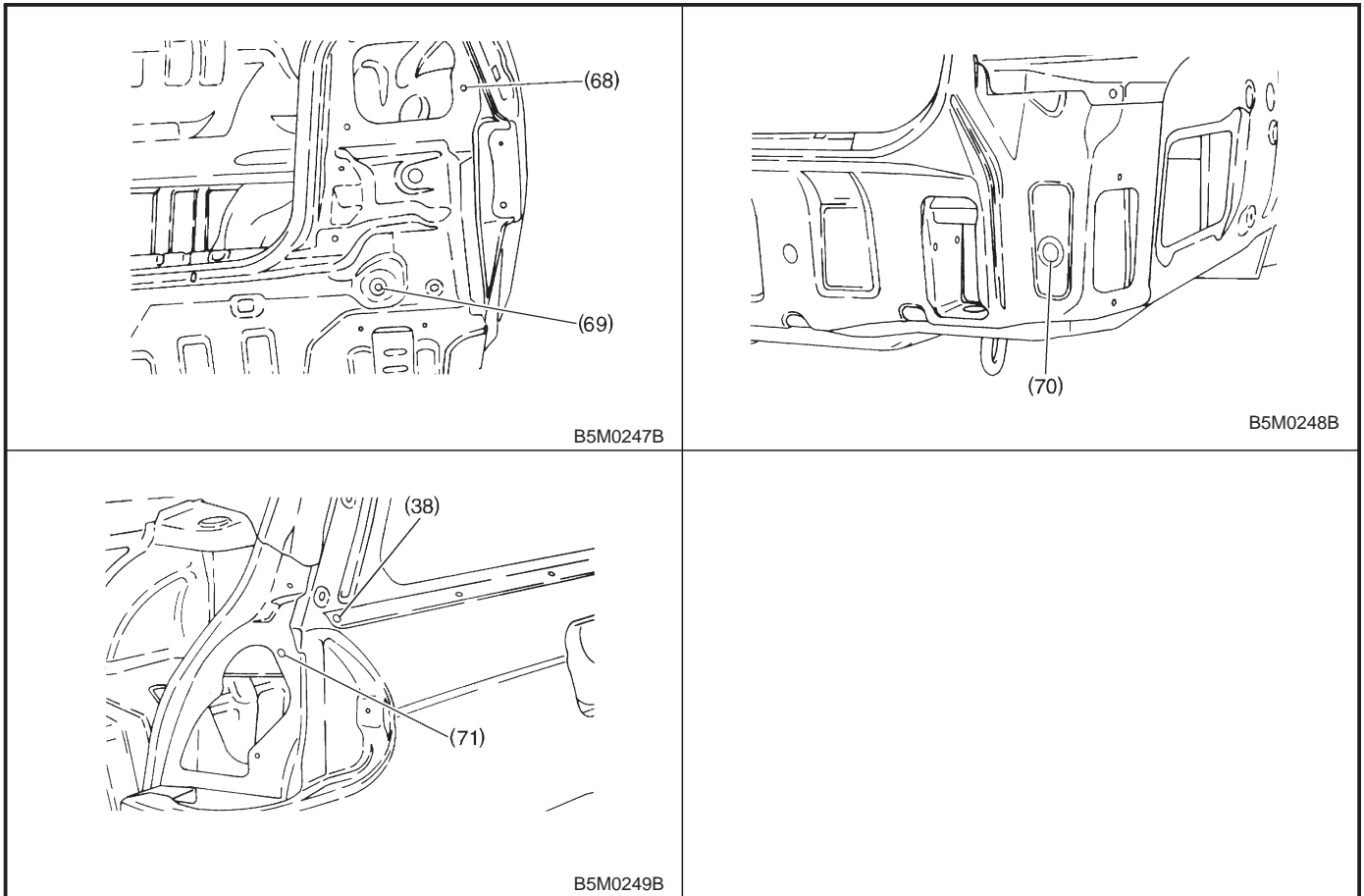

3. Datum Dimensions

Use a tram tracking gauge to measure all dimensions. If a measuring tape is used, be extremely careful because it tends to deflect or twist, which results in a false reading.

NOTE:

- A suffix character “R” or “L” refers to the right or the left.
- All dimensions refer to the distance between the centers of holes measured in a straight line.
- Each dimension indicates a projected dimension between hole centers.

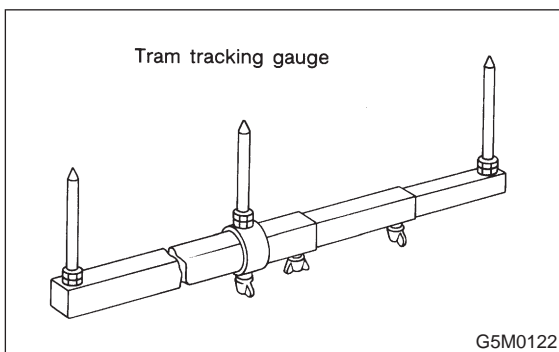

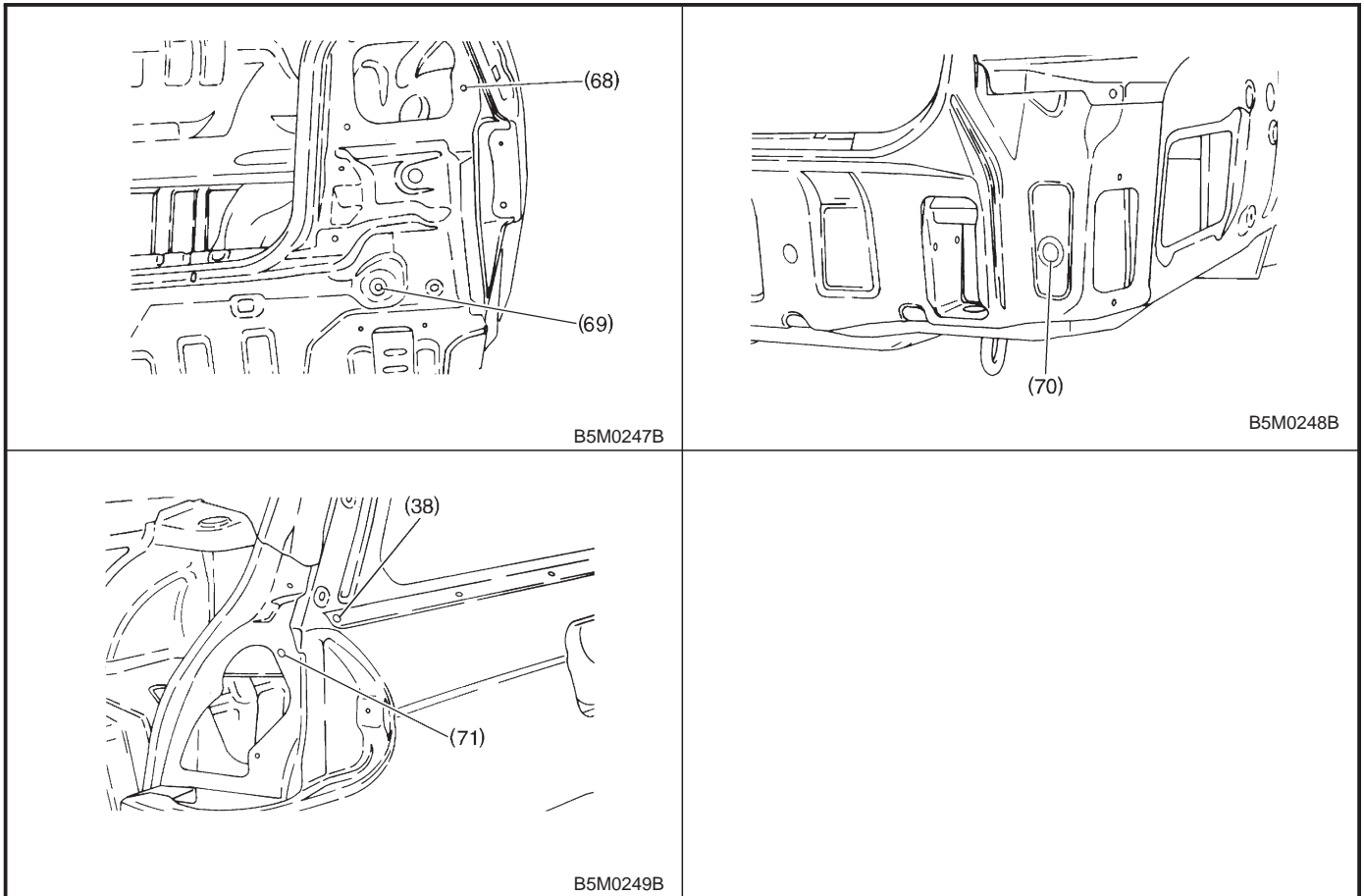

3. Datum Dimensions

Use a tram tracking gauge to measure all dimensions. If a measuring tape is used, be extremely careful because it tends to deflect or twist, which results in a false reading.

NOTE:

- A suffix character “R” or “L” refers to the right or the left.
- All dimensions refer to the distance between the centers of holes measured in a straight line.
- Each dimension indicates a projected dimension between hole centers.

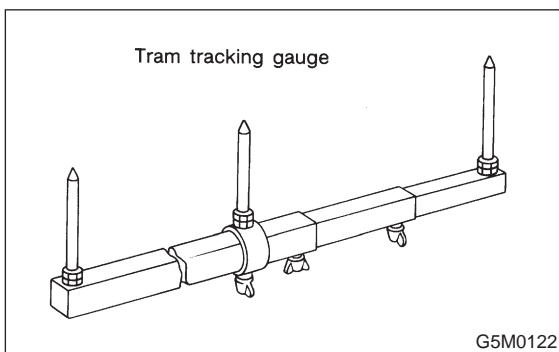

A: FRONT STRUCTURE

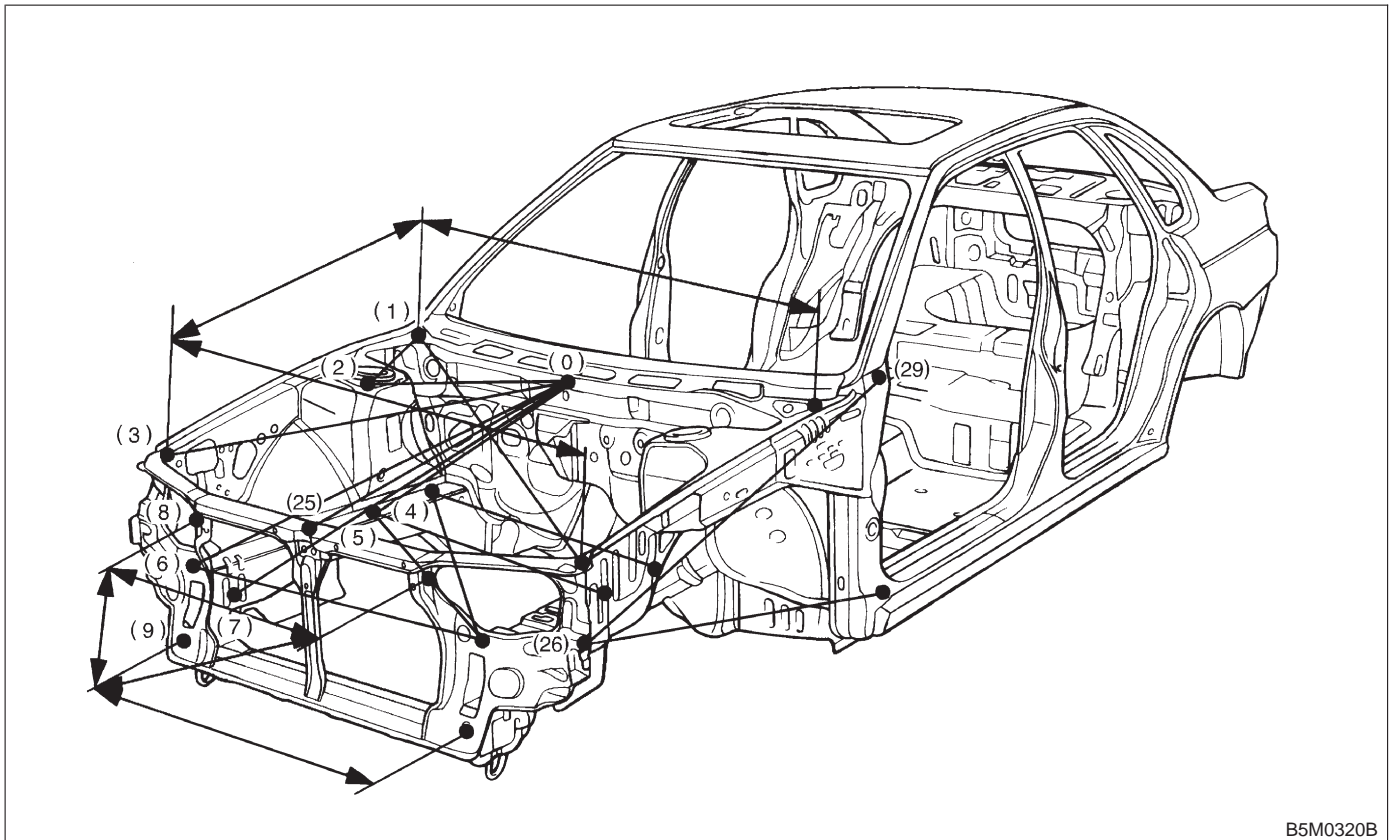

B5M0320B

Point to point	Dimension	Point to point	Dimension
(0) to (2) RH	522 (20.55)	(1) RH to (3) RH	845 (33.27)
(0) to (2) LH	522 (20.55)	(1) LH to (3) LH	845 (33.27)
(0) to (6) RH	980 (38.58)	(8) RH to (8) RH	347 (13.66)
(0) to (6) LH	980 (38.58)	(8) LH to (8) LH	347 (13.66)
(0) to (7) RH	966 (38.03)	(1) RH to (1) LH	1,408 (55.43)
(0) to (7) LH	966 (38.03)	(1) RH to (3) LH	1,623 (63.90)
(0) to (3) RH	1,008 (39.68)	(3) RH to (1) LH	1,623 (63.90)
(0) to (3) LH	1,008 (39.68)	(3) RH to (3) LH	1,364 (53.70)
(0) to (25)	863 (33.98)	(4) RH to (4) LH	803 (31.61)
(1) RH to (2) RH	373 (14.69)	(9) RH to (9) LH	924 (36.38)
(1) LH to (2) LH	373 (14.69)	(9) RH to (8) LH	892 (35.12)
(2) RH to (2) LH	966 (38.03)	(8) RH to (9) LH	892 (35.12)
(5) RH to (5) LH	850 (33.46)	(8) RH to (8) LH	730 (28.74)
(5) RH to (6) LH	1,011 (39.80)	(26) RH to (29) LH	1,191 (46.89)
(6) RH to (5) LH	1,011 (39.80)	(26) LH to (29) RH	1,191 (46.89)
(6) RH to (6) LH	914 (35.98)	(26) RH to (27) LH	1,144 (45.04)
(4) RH to (6) LH	1,115 (43.90)	(26) LH to (27) RH	1,144 (45.04)
(6) RH to (4) LH	1,115 (43.90)		

Unit: mm (in)

B: CENTER STRUCTURE

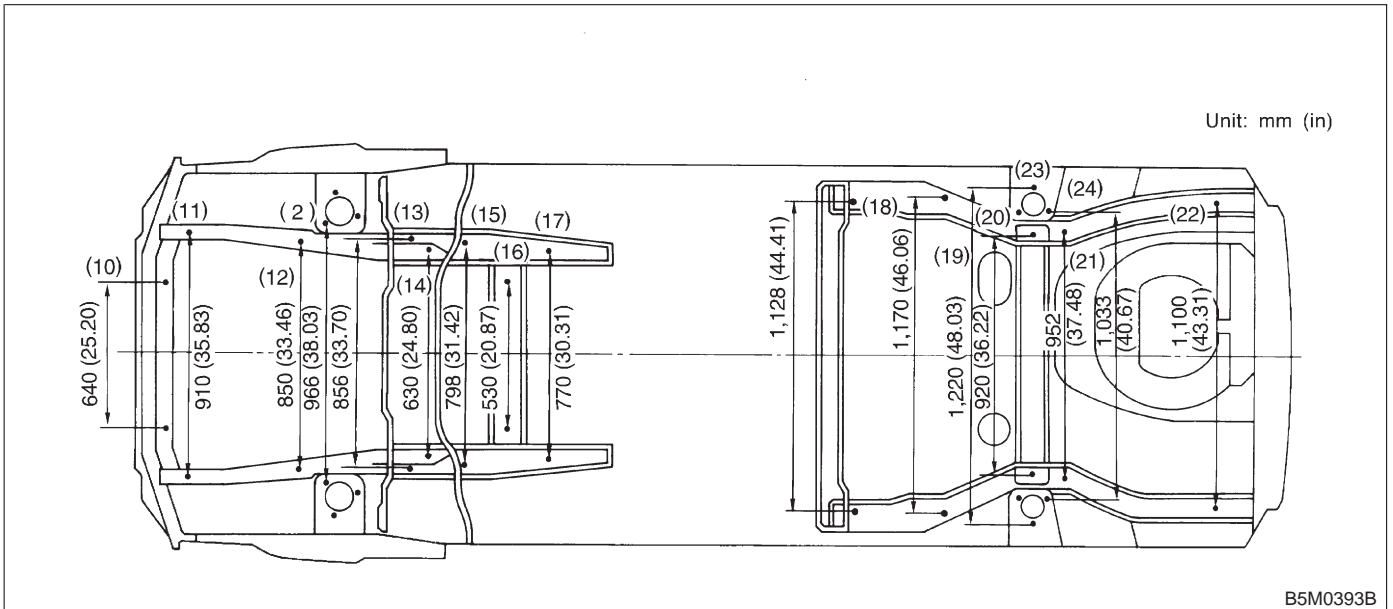
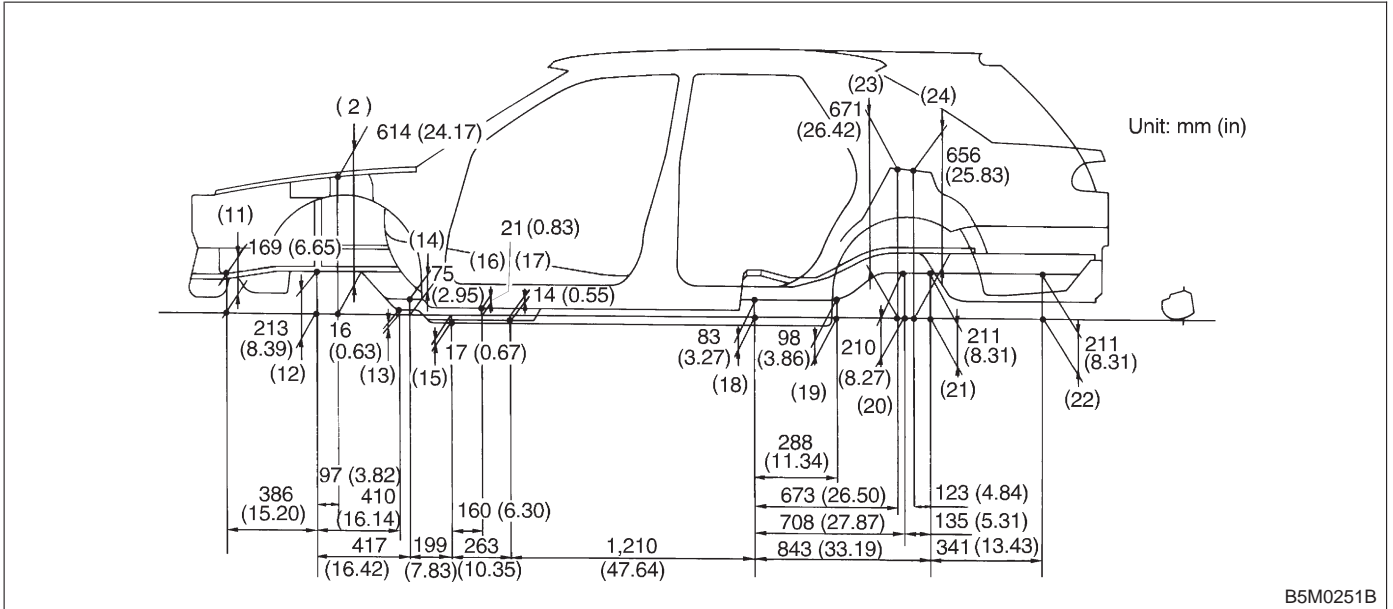

5-1 [S3B0]

3. Datum Dimensions

SPECIFICATIONS AND SERVICE DATA

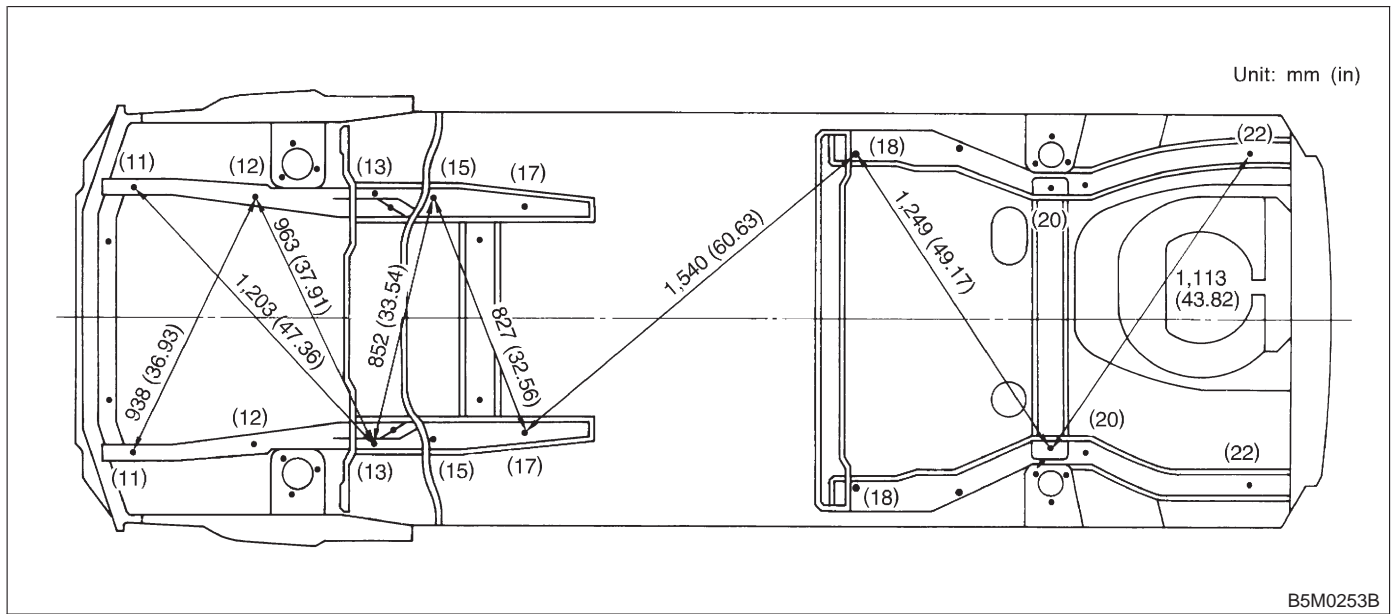

C: FRONT WINDSHIELD AND REAR WINDOW

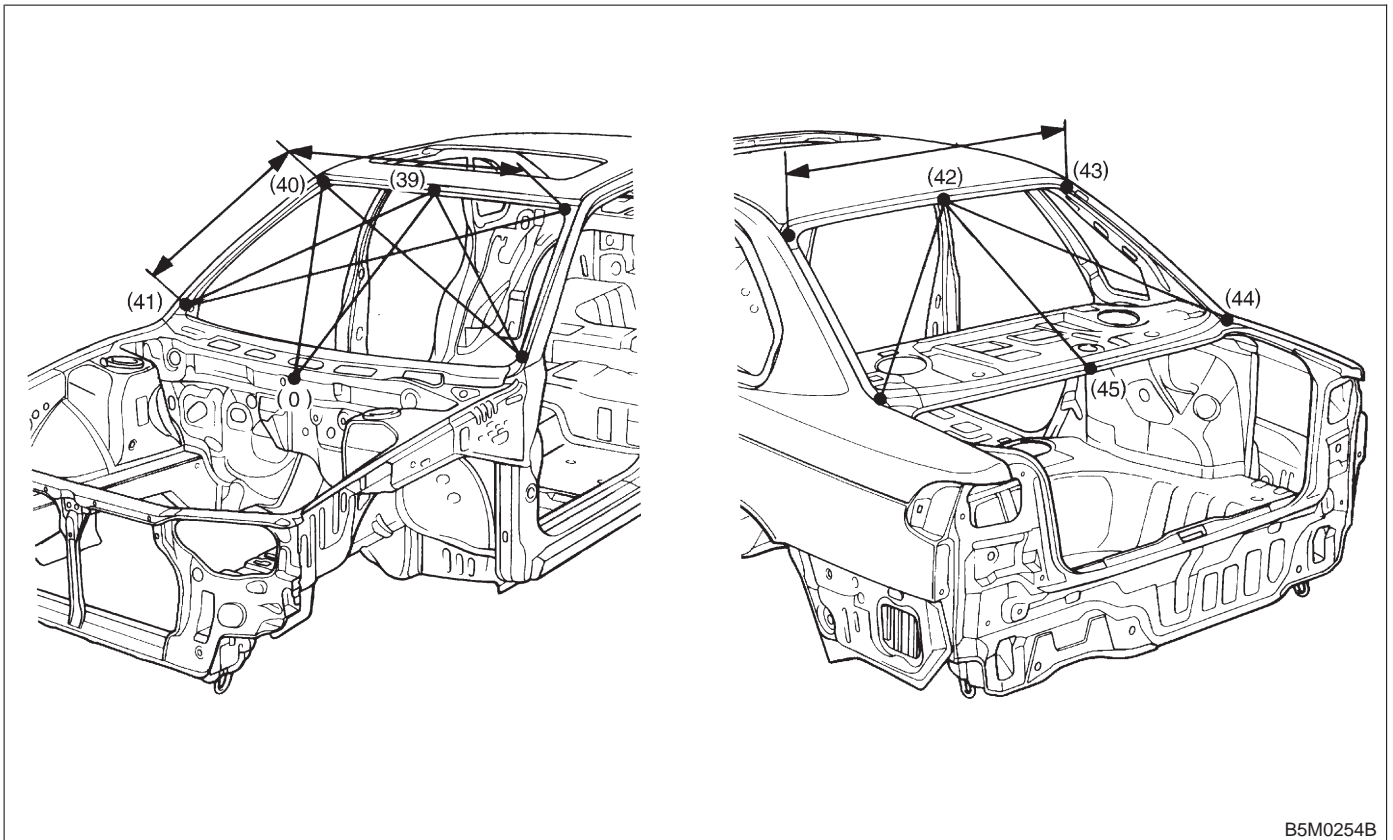

B5M0254B

Point to point	Dimension	Point to point	Dimension
(0) to (39)	934 (36.77)	(40) RH to (41) RH	700 (27.56)
(0) to (40) RH	1,133 (44.61)	(40) LH to (41) LH	700 (27.56)
(0) to (40) LH	1,133 (44.61)	(41) RH to (41) LH	1,396 (54.96)
(39) to (41) RH	940 (37.01)	(42) to (44) RH	871 (34.29)
(39) to (41) LH	940 (37.01)	(42) to (44) LH	871 (34.29)
(40) RH to (40) LH	1,076 (42.36)	(42) to (45)	760 (29.92)
(40) RH to (41) LH	1,411 (55.55)	(43) RH to (43) LH	986 (38.82)
(41) RH to (40) LH	1,411 (55.55)	(44) RH to (44) LH	1,216 (47.87)

Unit: mm (in)

D: DOORS

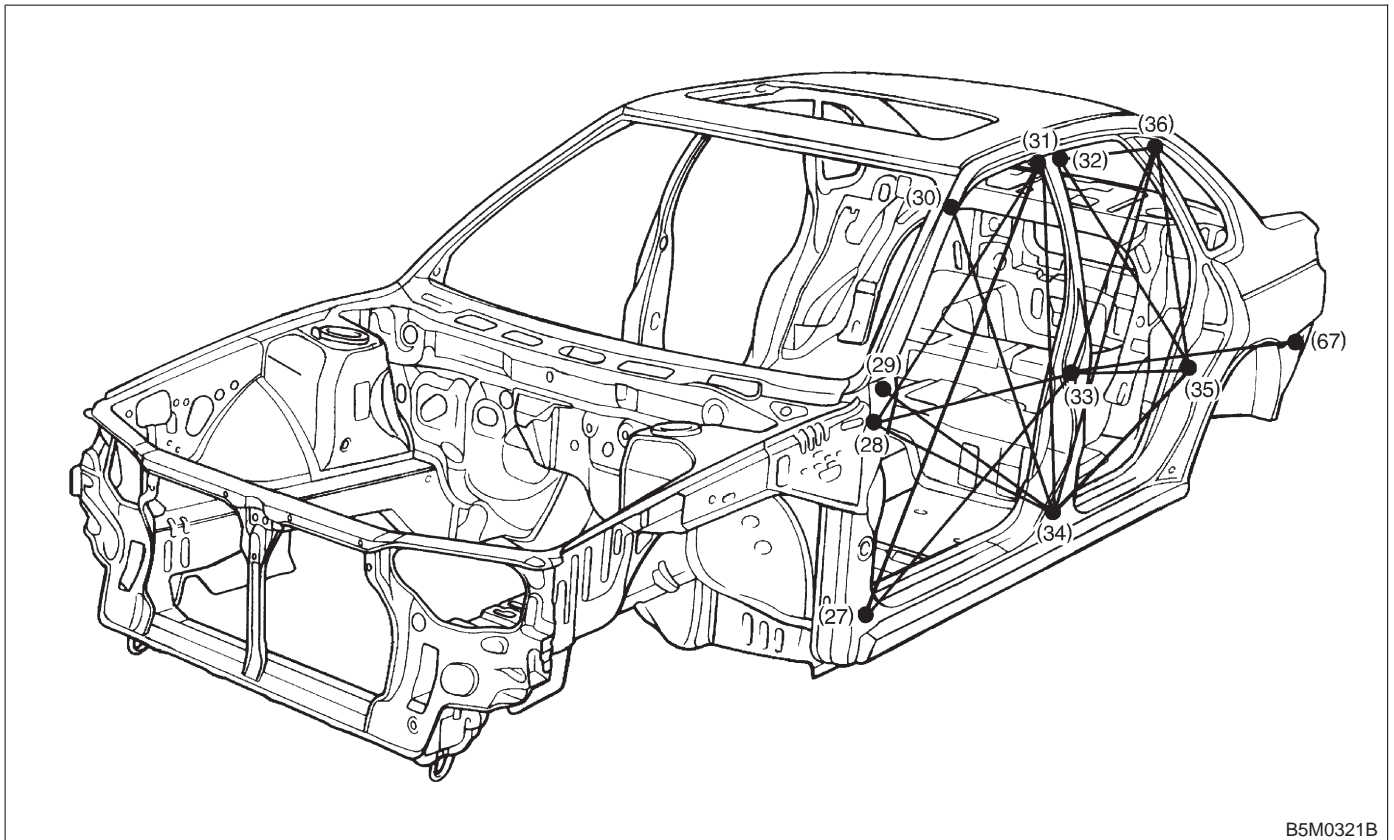

B5M0321B

Point to point	Dimension	Point to point	Dimension
(27) RH to (31) RH	1,445 (56.89)	(30) LH to (34) LH	974 (38.35)
(27) LH to (31) LH	1,445 (56.89)	(31) RH to (34) RH	931 (36.65)
(27) RH to (33) RH	1,087 (42.80)	(31) LH to (34) LH	931 (36.65)
(27) LH to (33) LH	1,087 (42.80)	(34) RH to (35) RH	1,101 (43.35)
(27) RH to (34) RH	921 (36.26)	(34) LH to (35) LH	1,101 (43.35)
(27) LH to (34) LH	921 (36.26)	(34) RH to (36) RH	1,193 (46.97)
(28) RH to (31) RH	1,246 (49.06)	(34) LH to (36) LH	1,193 (46.97)
(28) LH to (31) LH	1,246 (49.06)	(32) RH to (35) RH	870 (34.25)
(28) RH to (33) RH	1,043 (41.06)	(32) LH to (35) LH	870 (34.25)
(28) LH to (33) LH	1,043 (41.06)	(33) RH to (35) RH	891 (35.08)
(28) RH to (34) RH	1,029 (40.51)	(33) LH to (35) LH	891 (35.08)
(28) LH to (34) LH	1,029 (40.51)	(35) RH to (36) RH	471 (18.54)
(29) RH to (34) RH	1,020 (40.16)	(35) LH to (36) LH	471 (18.54)
(29) LH to (34) LH	1,020 (40.16)	(33) RH to (67) RH	1,773 (69.80)
(30) RH to (34) RH	974 (38.35)	(33) LH to (67) LH	1,773 (69.80)

Unit: mm (in)

E: TRUNK LID AND REAR GATE

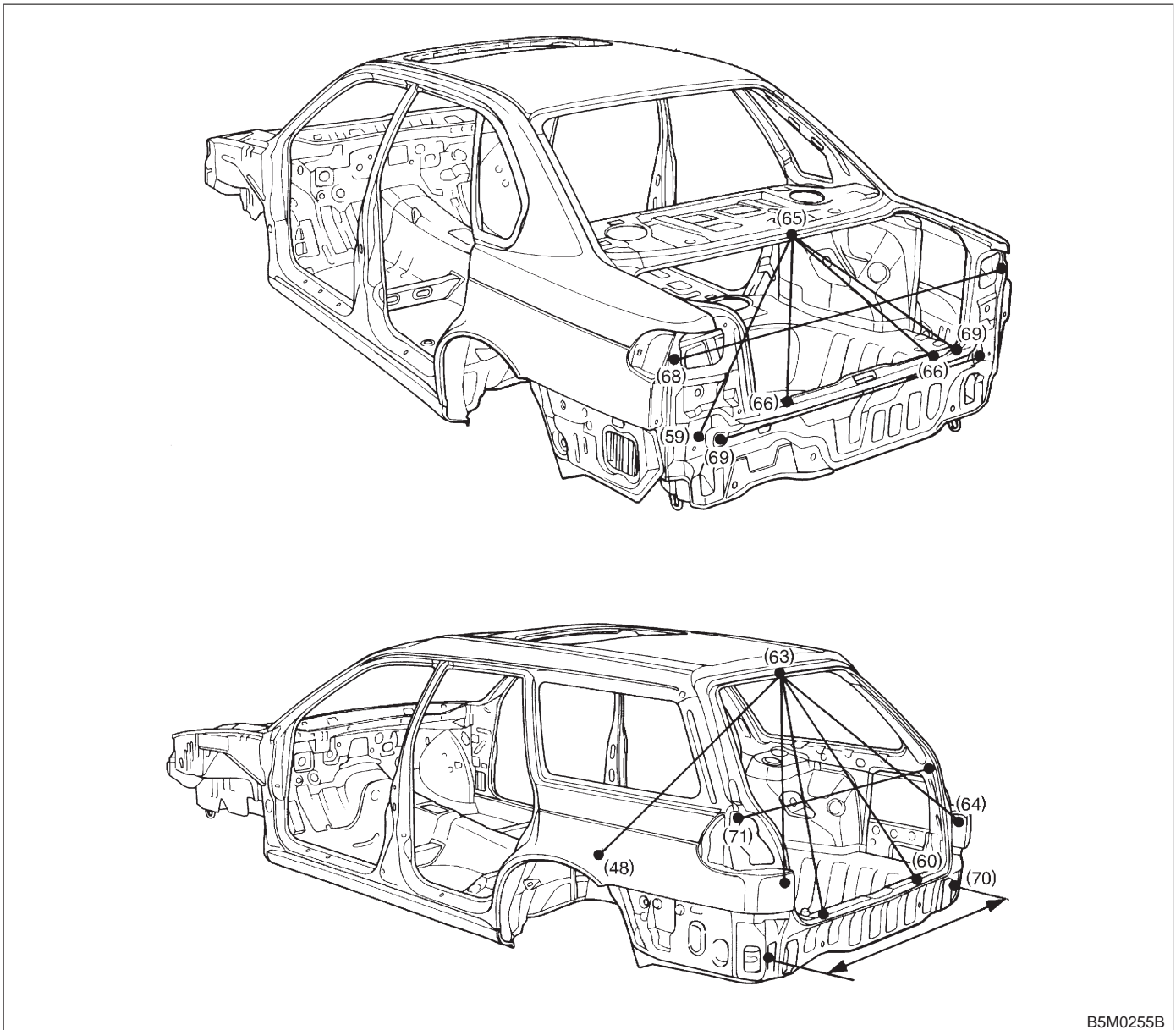

B5M0255B

Point to point	Dimension	Point to point	Dimension
(68) RH to (68) LH	1,346 (52.99)	(64) RH to (64) LH	1,213 (47.76)
(69) RH to (69) LH	1,080 (42.52)	(63) to (64) RH	990 (38.98)
(65) to (59) RH	771 (30.35)	(63) to (64) LH	990 (38.98)
(65) to (59) LH	785 (30.91)	(63) to (60) RH	1,003 (39.49)
(65) to (66) RH	592 (23.31)	(63) to (60) LH	1,003 (39.49)
(65) to (66) LH	604 (23.78)	(60) RH to (64) LH	984 (38.74)
(48) to (60) RH	1,707 (67.20)	(60) LH to (64) RH	984 (38.74)
(48) to (60) LH	1,707 (67.20)	(71) RH to (71) LH	1,393 (54.84)
(48) to (63)	1,466 (57.72)	(70) RH to (70) LH	1,320 (51.97)

Unit: mm (in)

F: COMPARTMENT

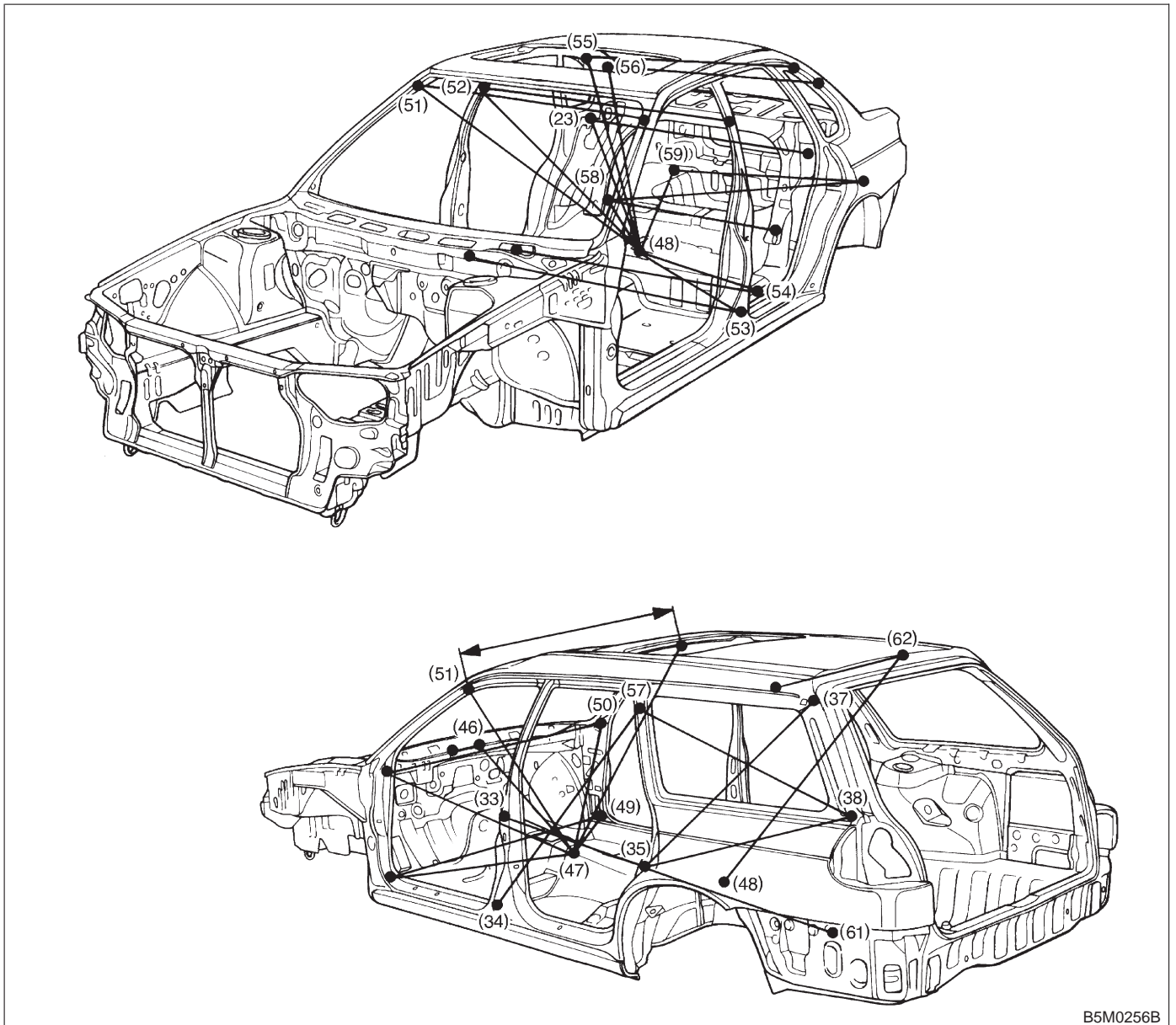

B5M0256B

SPECIFICATIONS AND SERVICE DATA

[S3F0] **5-1**

3. Datum Dimensions

Point to point	Dimension	Point to point	Dimension	Point to point	Dimension
(48) to (51) RH	1,315 (51.77)	(51) RH to (51) LH	1,148 (45.20)	(47) to (51) RH	992 (39.06)
(48) to (51) LH	1,315 (51.77)	(52) RH to (52) LH	1,153 (45.39)	(47) to (51) LH	998 (39.29)
(48) to (52) RH	1,033 (40.67)	(53) RH to (53) LH	1,534 (60.39)	(48) to (62) RH*	1,327 (52.24)
(48) to (52) LH	1,033 (40.67)	(54) RH to (54) LH	1,220 (48.03)	(48) to (62) LH*	1,327 (52.24)
(48) to (53) RH	866 (34.09)	(23) RH to (54) LH	1,520 (59.84)	(62) RH to (62) LH*	1,000 (39.37)
(48) to (53) LH	866 (34.09)	(23) LH to (54) RH	1,520 (59.84)	(35) RH to (37) RH*	805 (31.69)
(48) to (54) RH	612 (24.09)	(55) RH to (55) LH	1,307 (40.83)	(35) LH to (37) LH*	805 (31.69)
(48) to (54) LH	612 (24.09)	(56) RH to (56) LH	1,206 (47.48)	(35) RH to (38) RH*	928 (36.54)
(48) to (55) RH	1,120 (44.09)	(23) RH to (23) LH	1,210 (47.64)	(35) LH to (38) LH*	928 (36.54)
(48) to (55) LH	1,120 (44.09)	(58) RH to (58) LH	1,000 (39.37)	(49) RH to (49) LH*	1,399 (55.08)
(48) to (56) RH	1,201 (47.28)	(58) RH to (59) LH	1,435 (56.50)	(50) RH to (50) LH*	1,378 (54.25)
(48) to (56) LH	1,201 (47.28)	(59) RH to (58) LH	1,435 (56.50)	(34) RH to (57) RH*	1,207 (47.52)
(48) to (23) RH	1,065 (41.93)	(59) RH to (59) LH	1,115 (43.90)	(34) LH to (57) LH*	1,207 (47.52)
(48) to (23) LH	1,065 (41.93)	(47) to (46)	840 (33.07)	(35) RH to (57) RH*	461 (18.15)
(48) to (58) RH	747 (29.41)	(47) to (49) RH	905 (35.63)	(35) LH to (57) LH*	461 (18.15)
(48) to (58) LH	747 (29.41)	(47) to (49) LH	913 (35.94)	(33) RH to (61) RH*	1,773 (69.80)
(48) to (59) RH	1,621 (63.82)	(47) to (50) RH	981 (38.62)	(33) LH to (61) LH*	1,773 (69.80)
(48) to (59) LH	1,621 (63.82)	(47) to (50) LH	988 (38.90)		

Unit: mm (in) *: Wagon only

4. Datum Points and Dimensions Concerning On-Board Aiming Adjustment

If headlight aiming is misaligned due to damaged body panel, repair headlight mating surface using body and headlight datum points as a guide.

NOTE:

It is recommended to conduct On-Board Aiming Adjustment with headlights turned off. If turned on during the adjustment, the duration should be within two minutes.

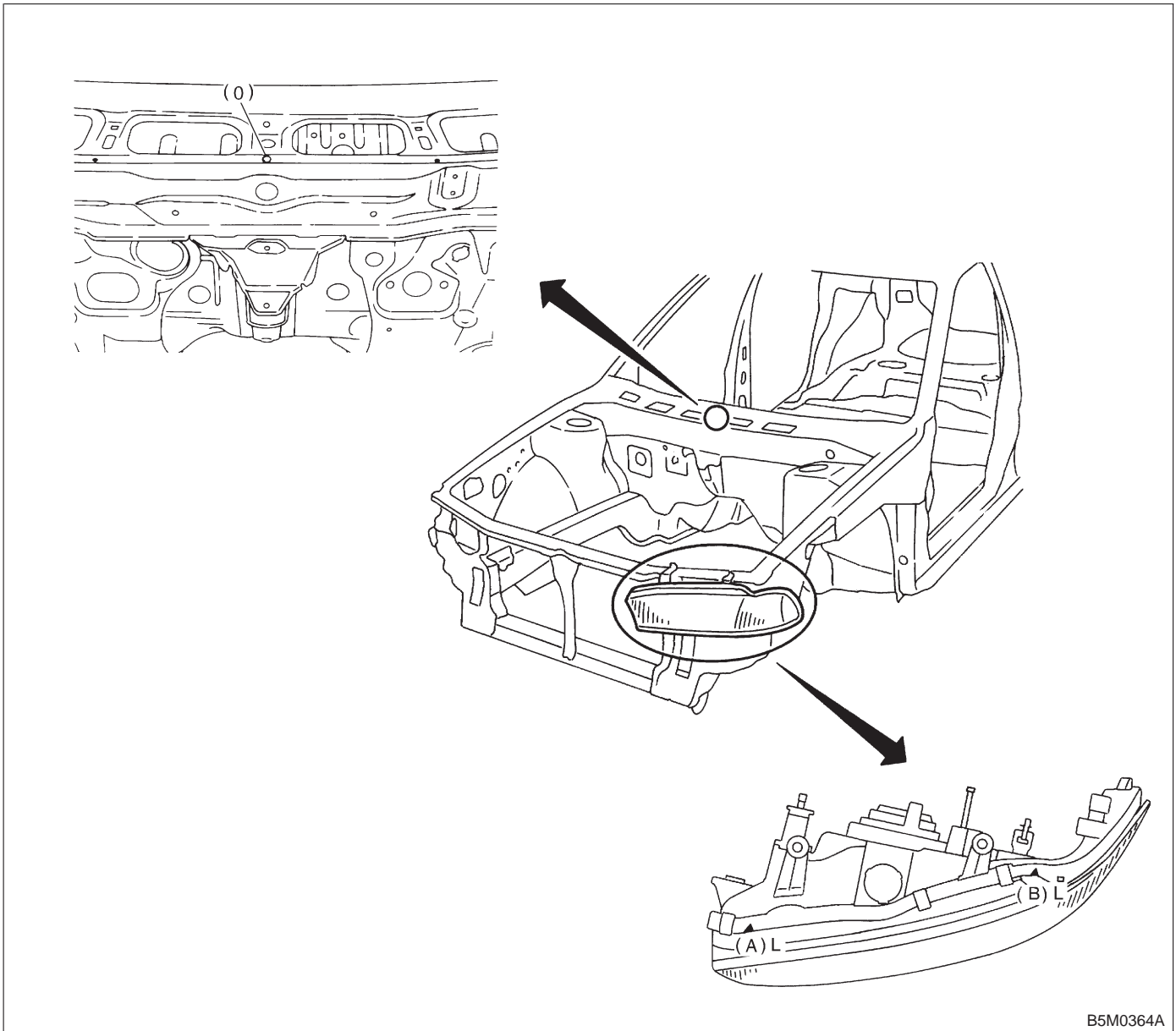

B5M0364A

Point to point	Dimension	Point to point	Dimension
(0) to (A) LH	1,015 (39.96)	(0) to (B) LH	1,057 (41.61)
(0) to (A) RH	1,015 (39.96)	(0) to (B) RH	1,057 (41.61)

Unit: mm (in)

1. Front Hood and Hood Lock

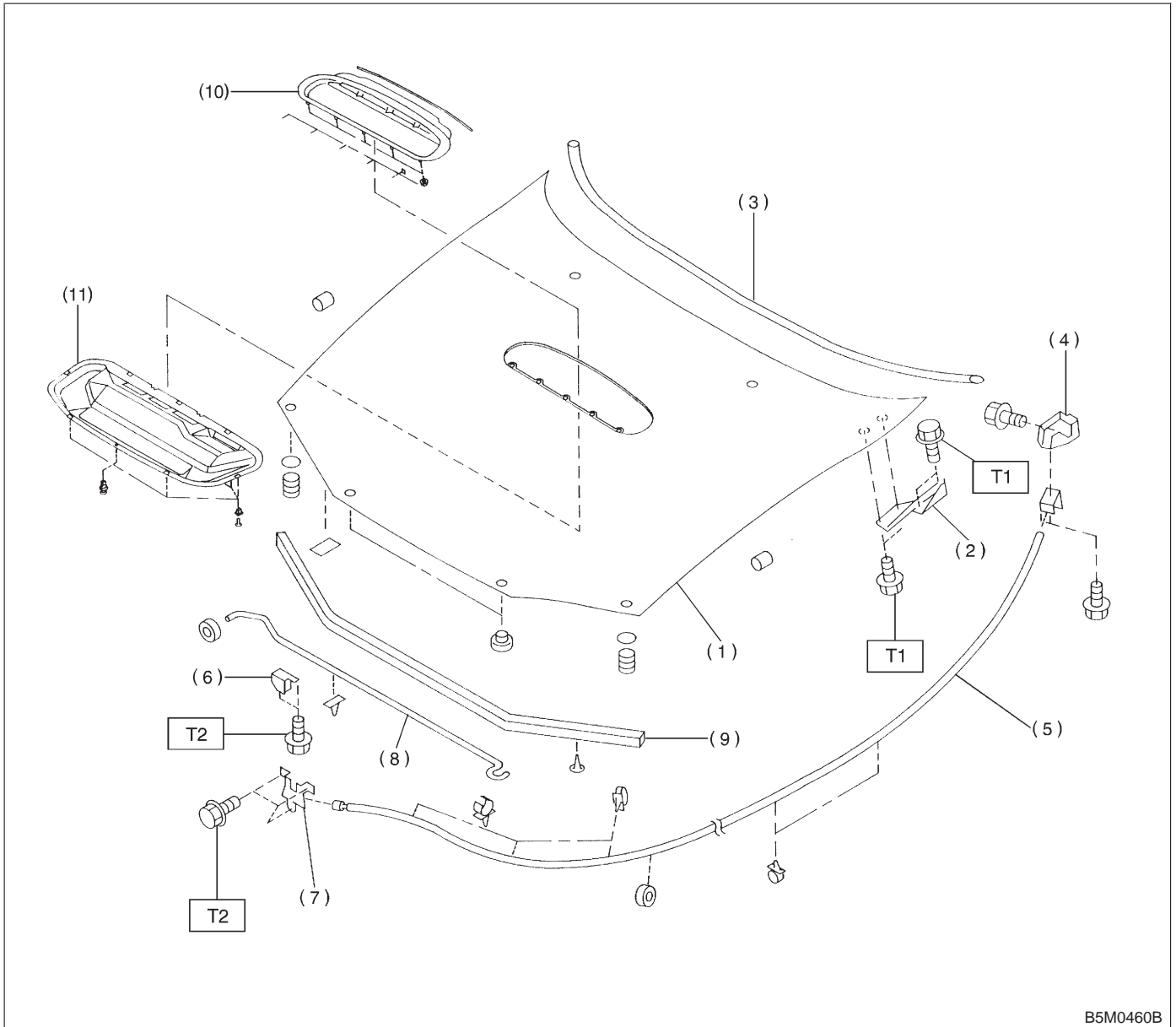

- | | | |
|---------------------|---------------------------------------|--|
| (1) Front hood | (7) Hood lock ASSY | (11) Hood inner (Outback and GT model) |
| (2) Hinge (RH, LH) | (8) Front hood stay | |
| (3) Front hood seal | (9) Front hood seal CTR | |
| (4) Lever ASSY | (10) Hood duct (Outback and GT model) | |
| (5) Cable | | |
| (6) Striker | | |

Tightening torque: N-m (kg-m, ft-lb)
T1: 14±9 (1.4±0.9, 10.1±6.5)
T2: 32±1 (3.3±0.1, 23.9±0.7)

2. Trunk Lid

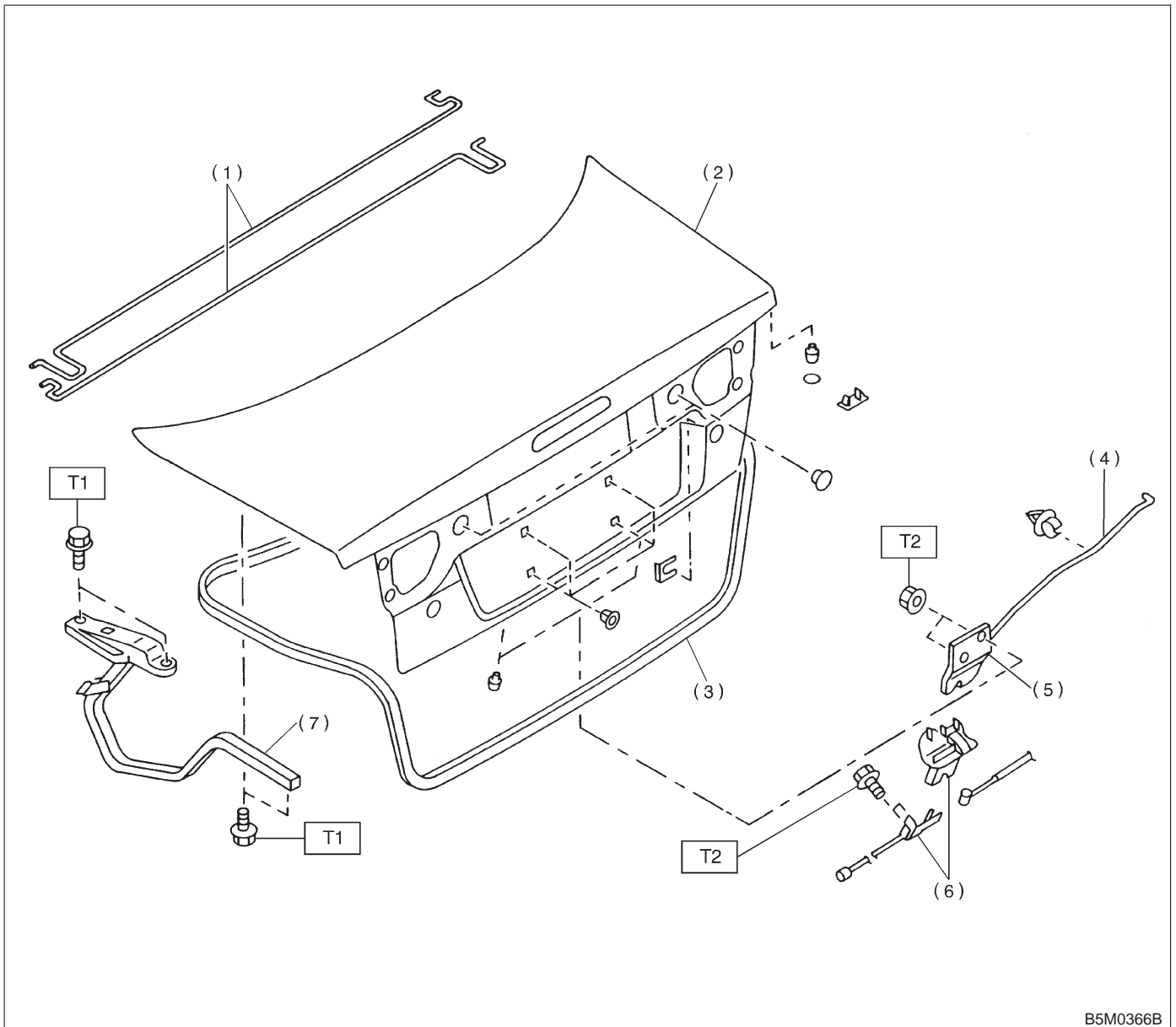

B5M0366B

- | | |
|------------------|-------------------------|
| (1) Torsion bar | (5) Trunk lid lock ASSY |
| (2) Trunk lid | (6) Striker |
| (3) Weatherstrip | (7) Hinge ASSY |
| (4) Rod | |

Tightening torque: N-m (kg-m, ft-lb)

T1: 14±4 (1.4±0.4, 10.1±2.9)

T2: 18±5 (1.8±0.5, 13.0±3.6)

3. Front Bumper

A: EXCEPT OUTBACK MODEL

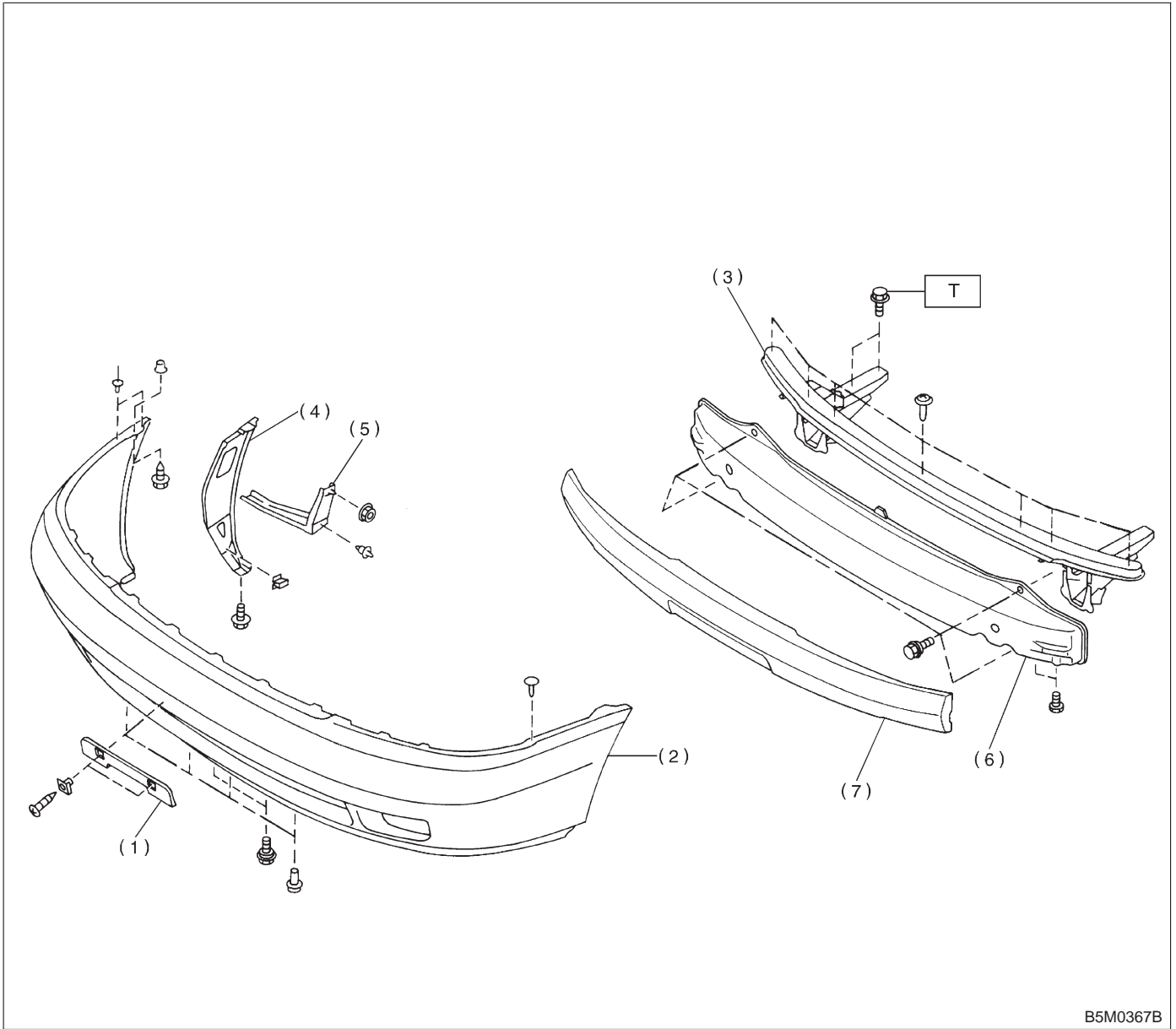

B5M0367B

- | | |
|---------------------------|-----------------------|
| (1) Licence plate bracket | (5) Stay |
| (2) Bumper face | (6) Back beam (Front) |
| (3) Front bumper beam | (7) E-A foam (Front) |
| (4) Bracket | |

Tightening torque: N·m (kg·m, ft·lb)
T: 93±25 (9.5±2.5, 69±18)

B: OUTBACK MODEL

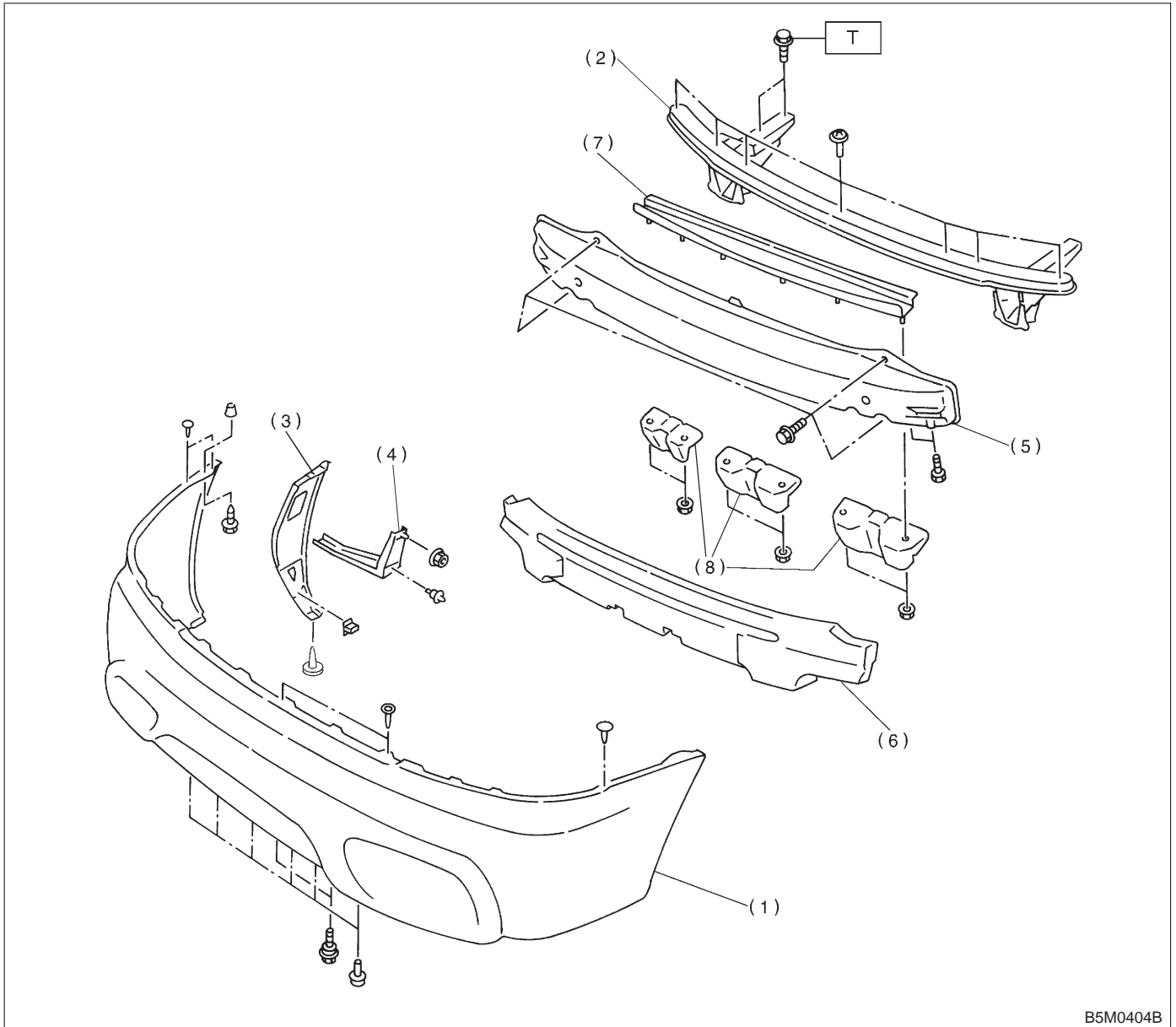

- | | |
|-----------------------|-----------------------|
| (1) Bumper face | (5) Back beam (Front) |
| (2) Front bumper beam | (6) E-A foam (Front) |
| (3) Bracket | (7) Holder |
| (4) Stay | (8) Back beam bracket |

Tightening torque: N·m (kg·m, ft·lb)
T: 93±25 (9.5±2.5, 69±18)

4. Rear Bumper

A: SEDAN

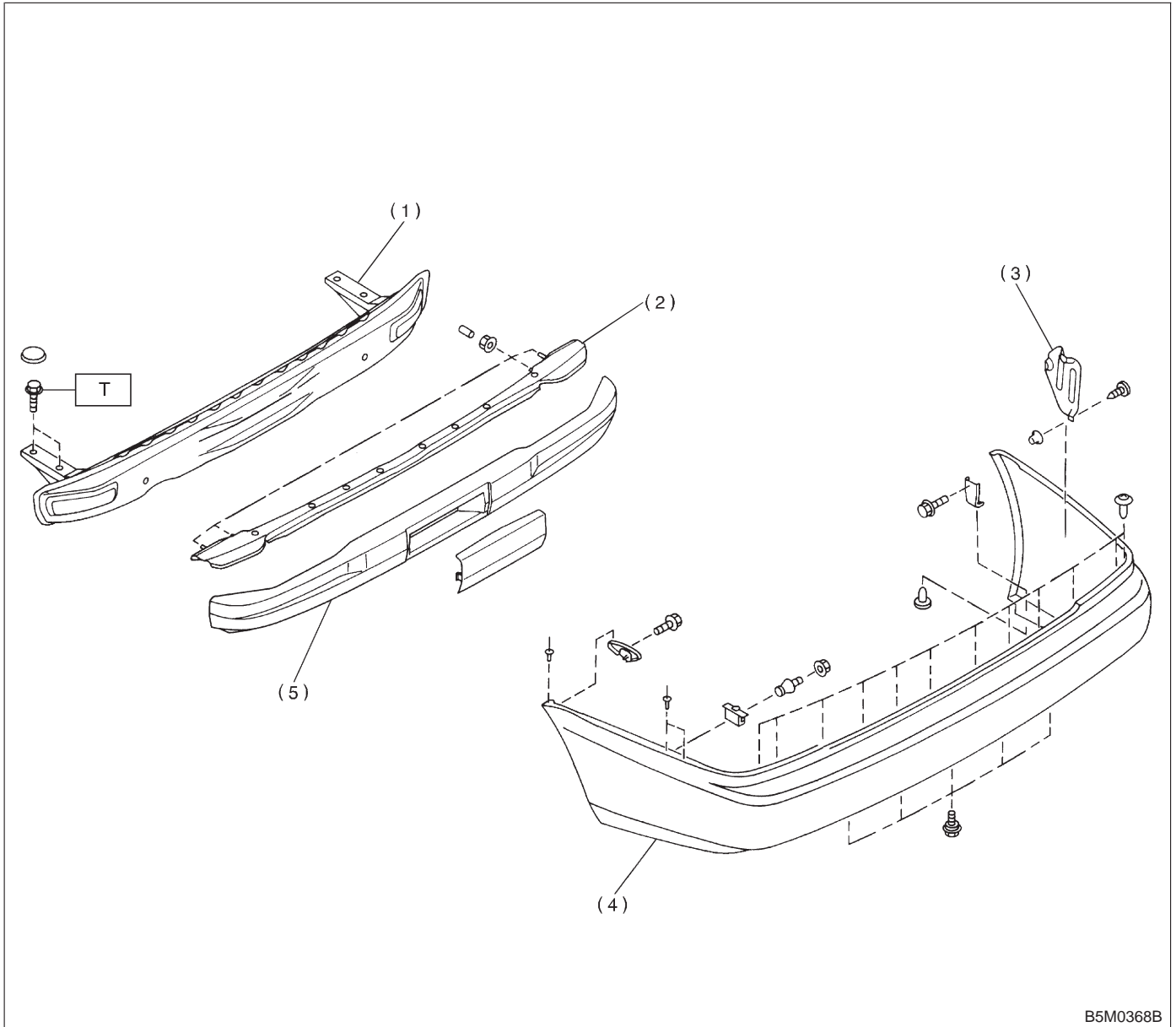

B5M0368B

- | | |
|-----------------------|---------------------|
| (1) Bumper beam (LWR) | (4) Bumper surface |
| (2) Bumper beam (UPR) | (5) E-A foam (Rear) |
| (3) Bracket (Side) | |

Tightening torque: N·m (kg·m, ft·lb)
T: 93±25 (9.5±2.5, 69±18)

B: WAGON

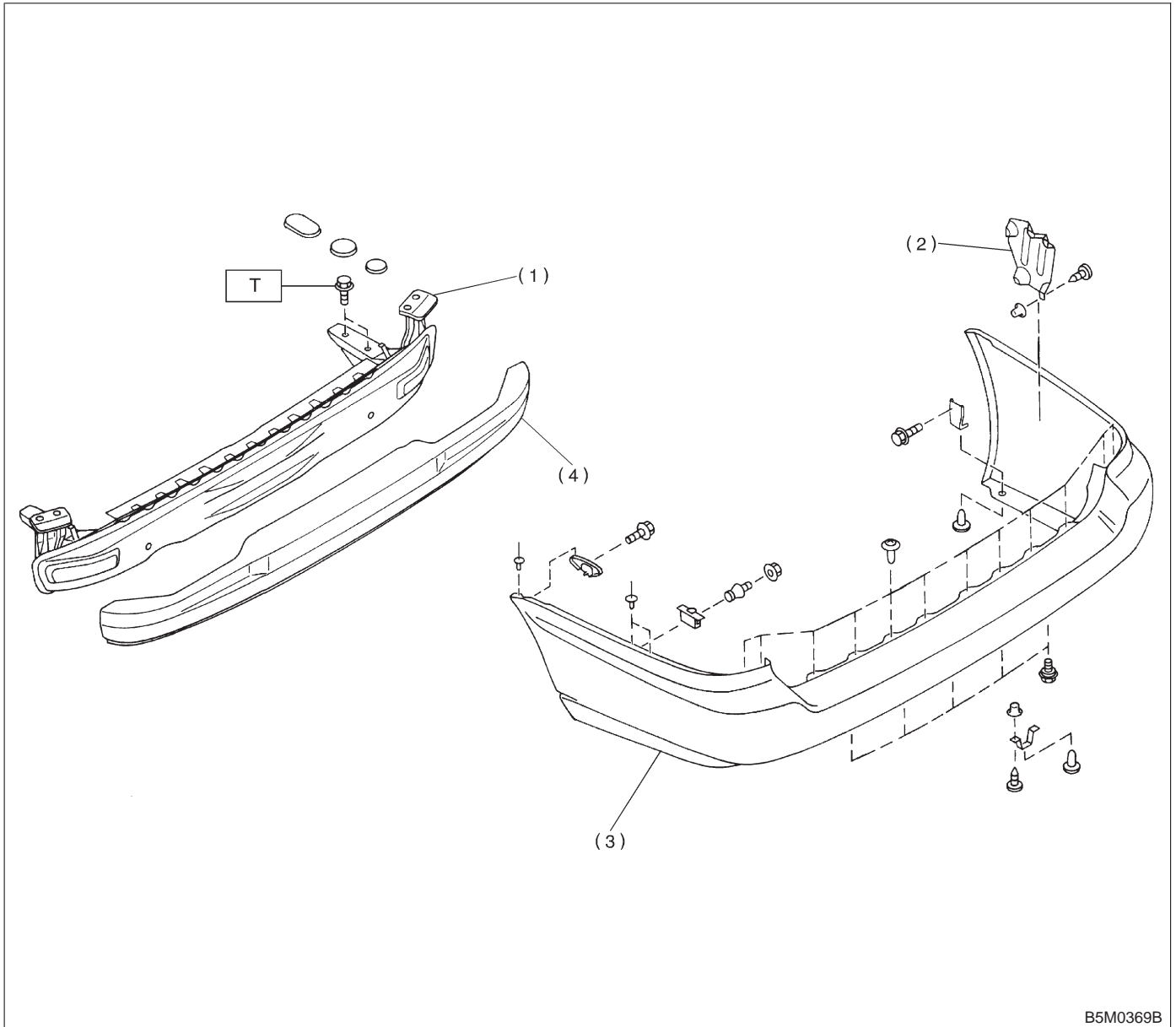

- (1) Bumper beam
- (2) Bracket (Side)
- (3) Bumper surface

- (4) E-A foam (Rear)

Tightening torque: N·m (kg·m, ft·lb)
T: 93±25 (9.5±2.5, 69±18)

C: OUTBACK MODEL

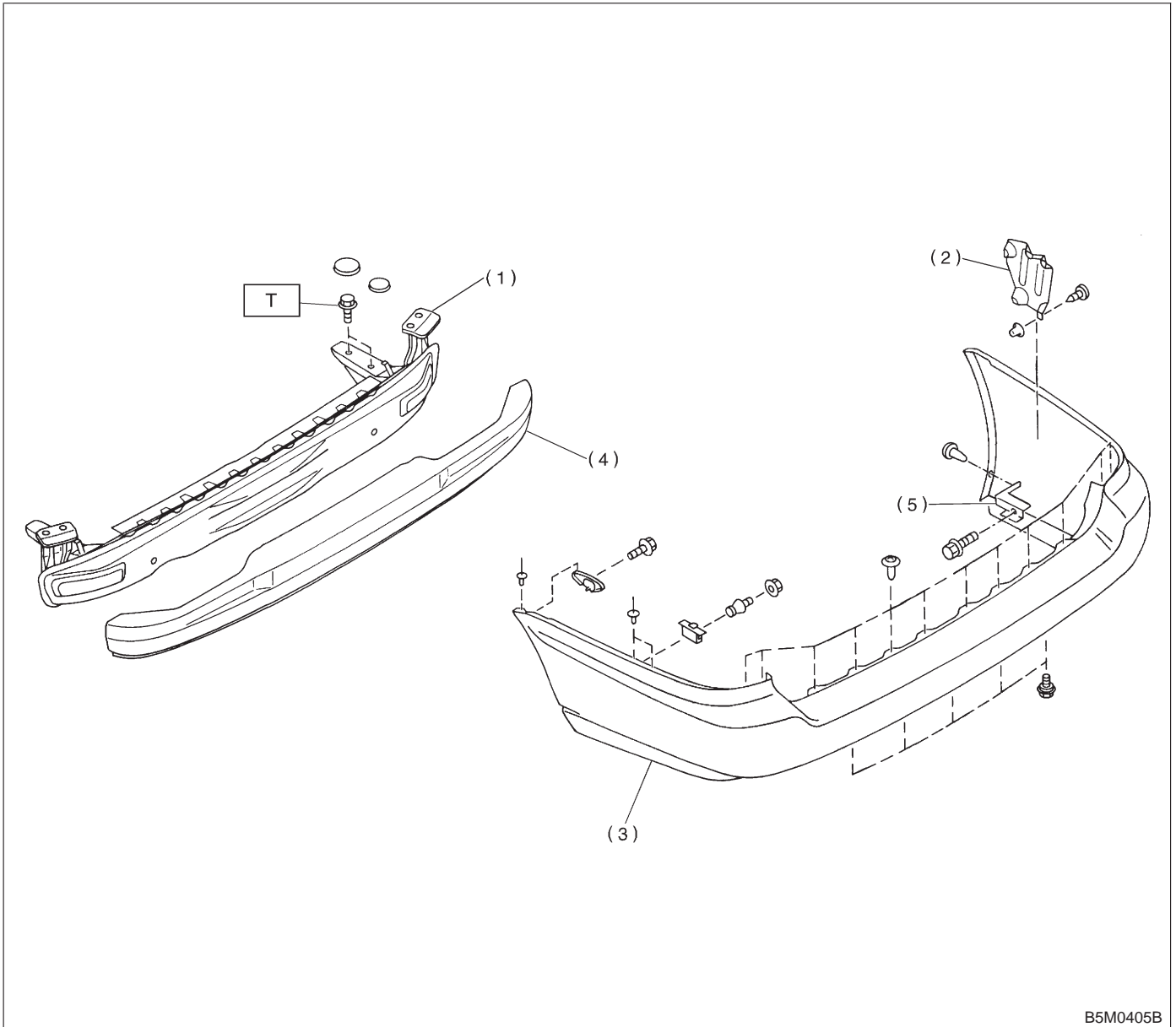

B5M0405B

- (1) Bumper beam
- (2) Bracket (Side)
- (3) Bumper surface
- (4) E-A foam (Rear)
- (5) Lower bracket (Side)

Tightening torque: N·m (kg·m, ft·lb)
T: 93±25 (9.5±2.5, 69±18)

D: SUS MODEL

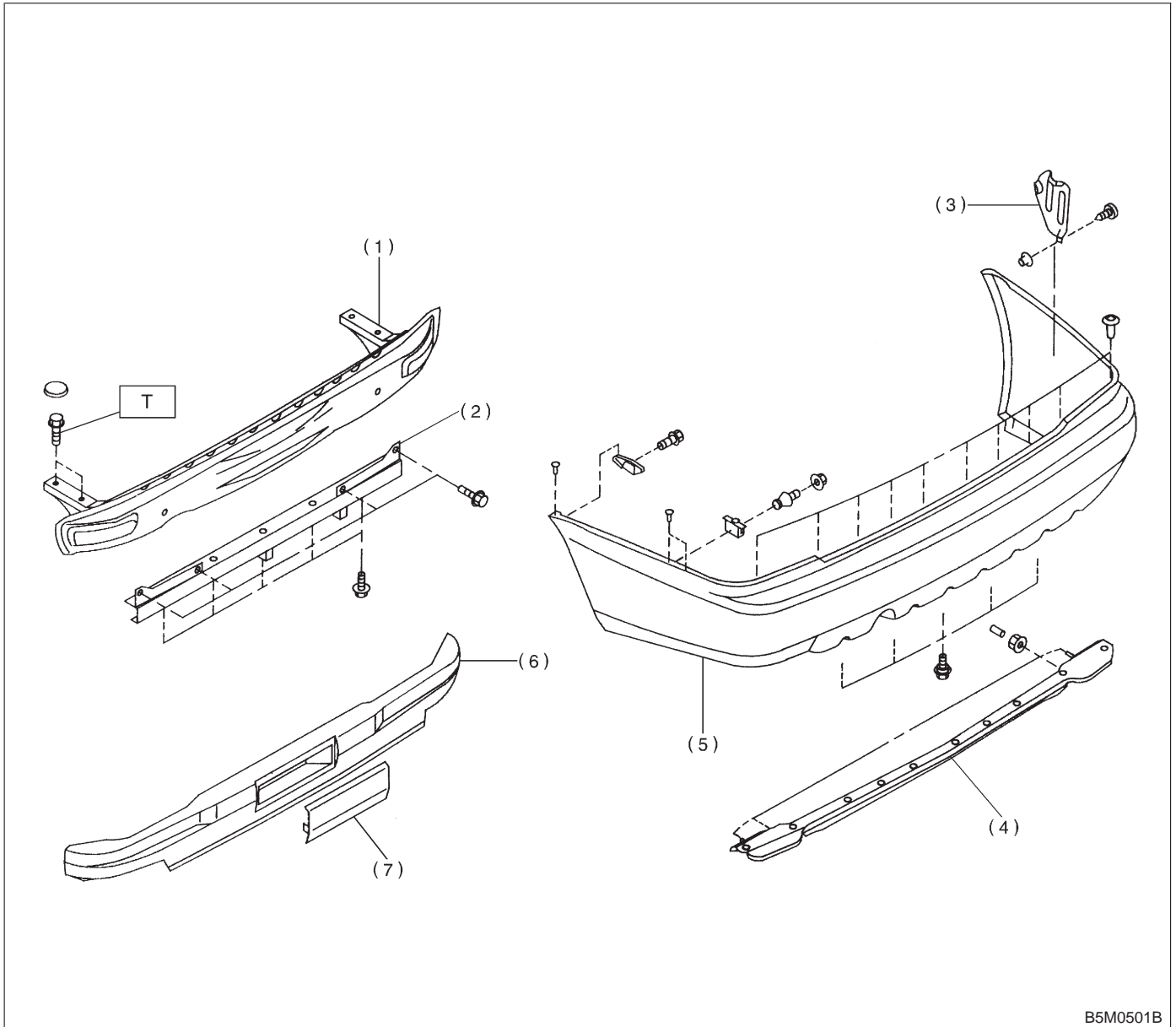

- | | |
|------------------------------|-------------------|
| (1) Beam complete rear | (5) Bumper face |
| (2) Beam lower complete rear | (6) E-A foam |
| (3) Bracket side rear | (7) E-A honeycomb |
| (4) Beam upper rear | |

Tightening torque: N·m (kg·m, ft·lb)
T: 95±25 (9.5±2.5, 69±18)

5. Sunroof

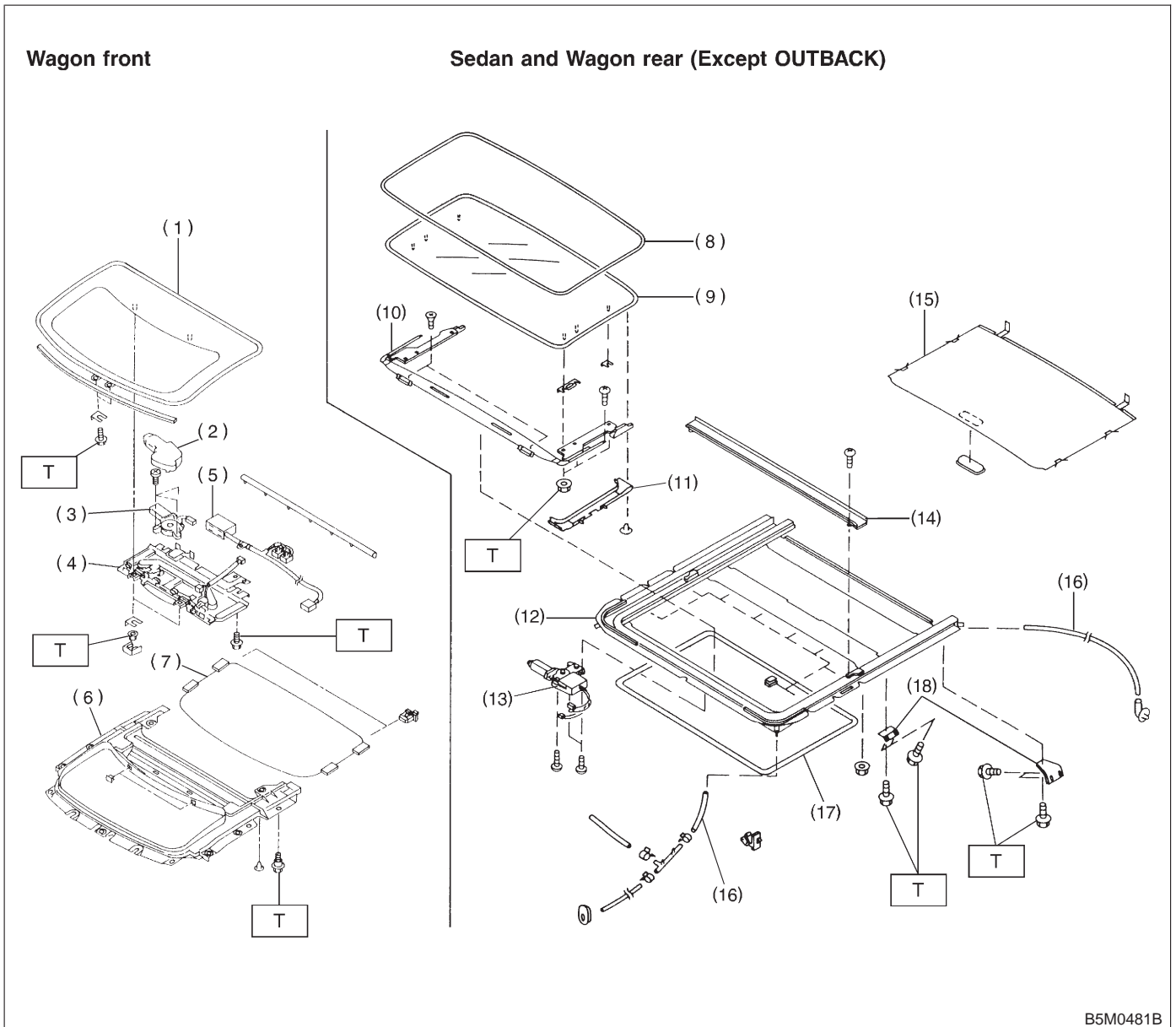

B5M0481B

- (1) Sunroof panel
- (2) Motor cover
- (3) Motor ASSY
- (4) Tilt up ASSY
- (5) Control module ASSY
- (6) Frame ASSY
- (7) Sunroof trim
- (8) Weatherstrip

- (9) Sunroof panel
- (10) Deflector and guide rail ASSY
- (11) Guide rail cover
- (12) Frame ASSY
- (13) Motor ASSY
- (14) Drain ASSY
- (15) Sunroof trim
- (16) Drain tube

- (17) Garnish (Sedan only)
- (18) Set bracket

Tightening torque: N-m (kg-m, ft-lb)
T: 7.4±2.0 (0.75±0.2, 5.4±1.4)

6. Steering Support Beam

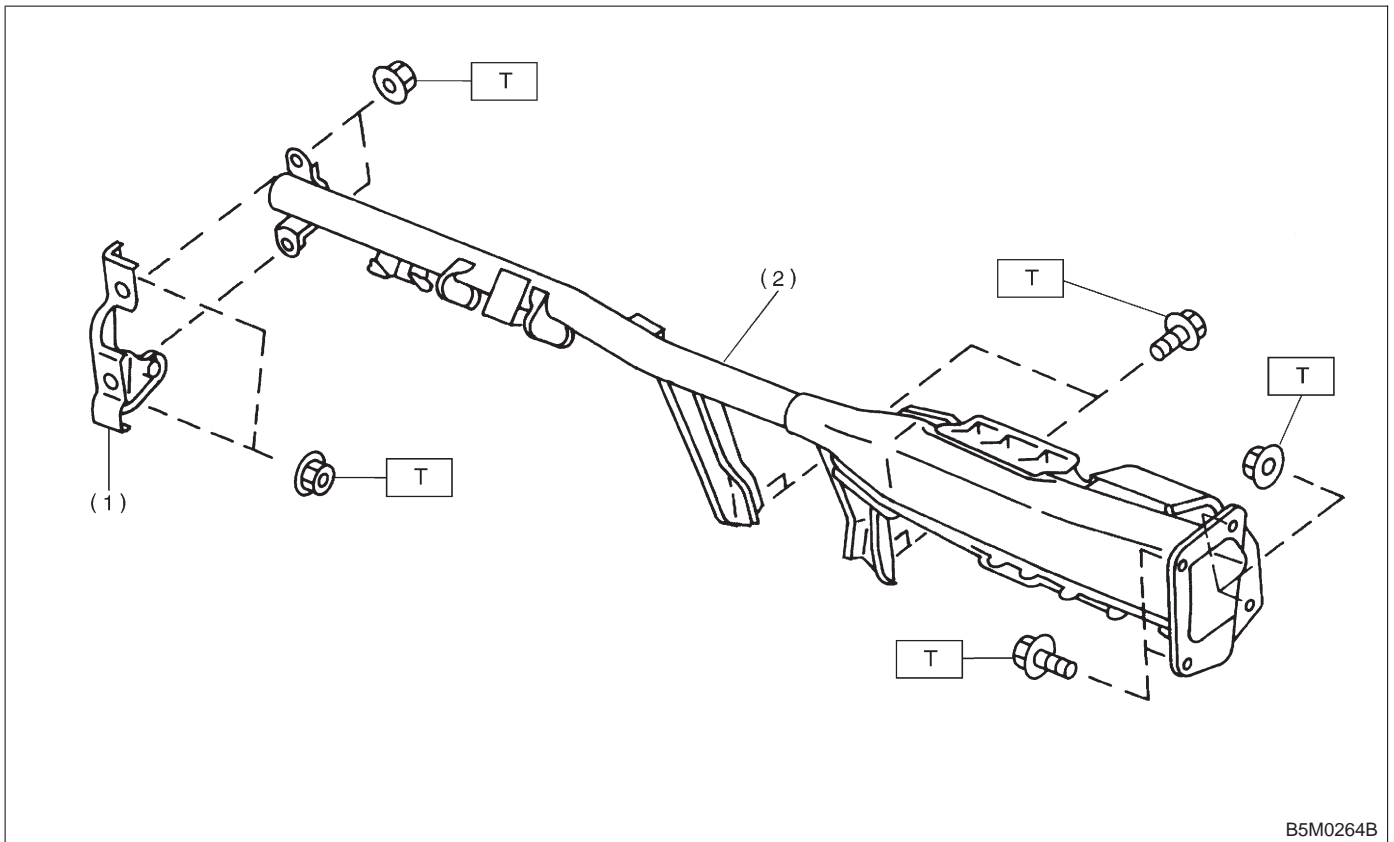

- (1) Bracket
- (2) Steering beam

Tightening torque: N·m (kg·m, ft·lb)
T: 32±10 (3.3±1.0, 23.9±7)

7. Guard Pipe

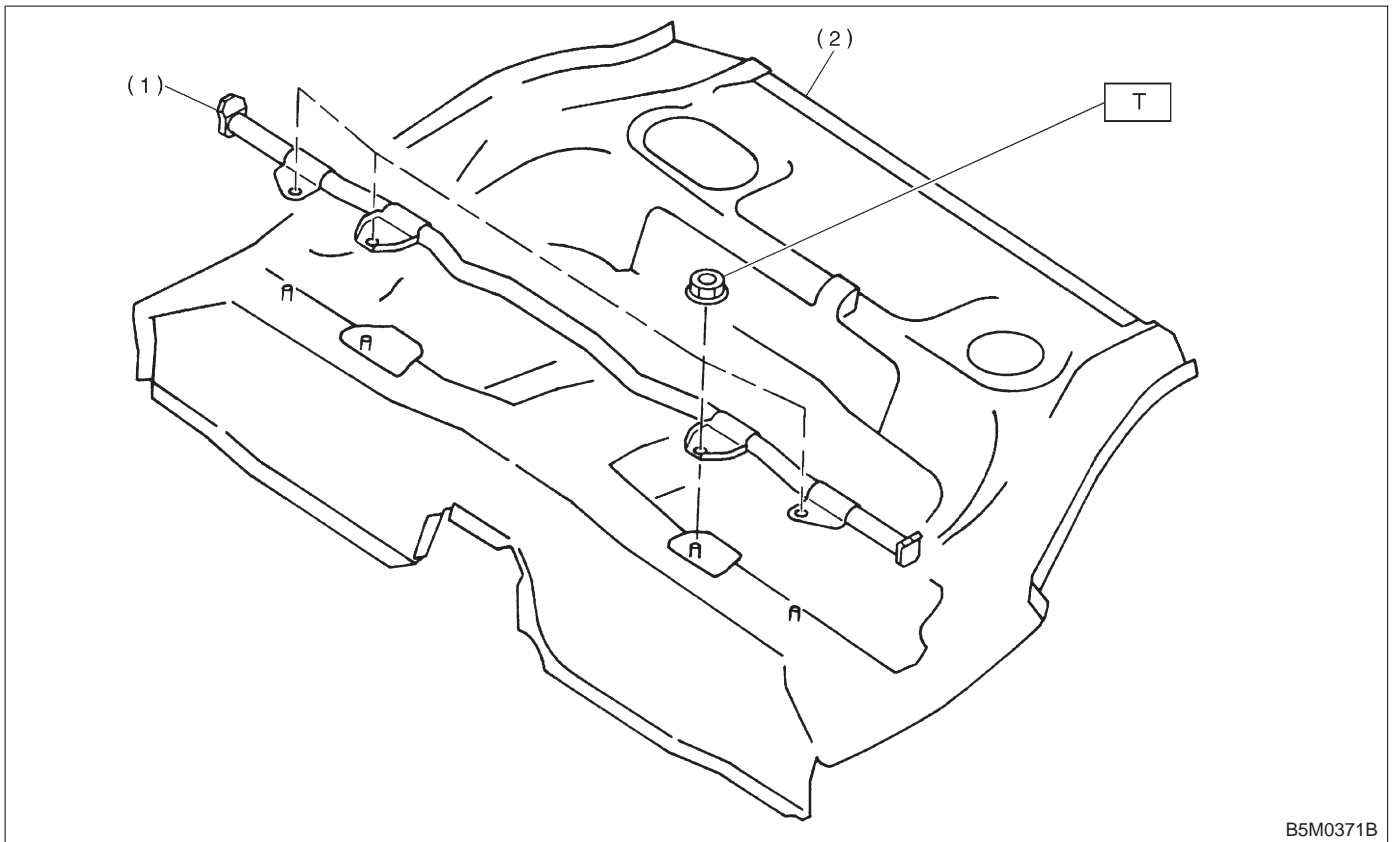

B5M0371B

- (1) Guard pipe
- (2) Rear floor panel

Tightening torque: N·m (kg·m, ft·lb)
T: 32±10 (3.3±1.0, 23.9±7)

1. Hood

A: REMOVAL AND INSTALLATION

NOTE:

The hood lock has a dual locking design which consists of a main lock and a safety lock mechanism. When the release knob located at the front pillar on the driver's side is pulled back, the main lock is released through the cable attached to the knob.

The safety lock can be released by pushing the lever protruding above the front grill while opening the hood.

1. HOOD

- 1) Open front hood, and remove washer hose.
- 2) Remove attaching bolts.

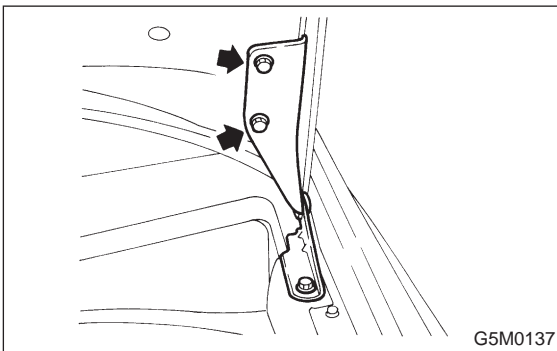

- 3) Detach front hood from hinges.
- 4) Installation is in the reverse order of removal.

CAUTION:

With buffer protruding about 18 mm (0.71 in) beyond radiator panel, make sure that:

- No clearance exists between buffer and inner hood.
- Hood main lock is applied when hood is released at a height of approximately 10 mm (0.39 in) above the closed position.

NOTE:

Align the center of striker with lock during installation. Make sure safety lever is properly caught by striker under the hood's own weight.

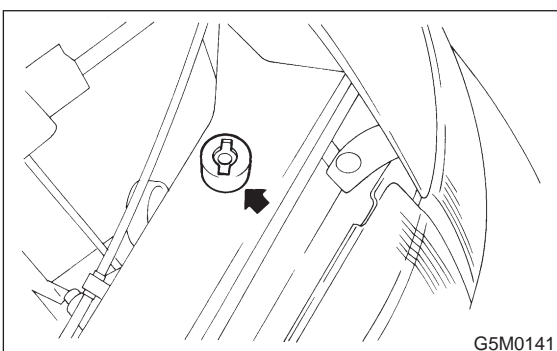

2. HOOD LOCK

- 1) Open front hood and remove front grille.
- 2) Remove bolts which secure lock assembly to radiator panel, and remove lock assembly.

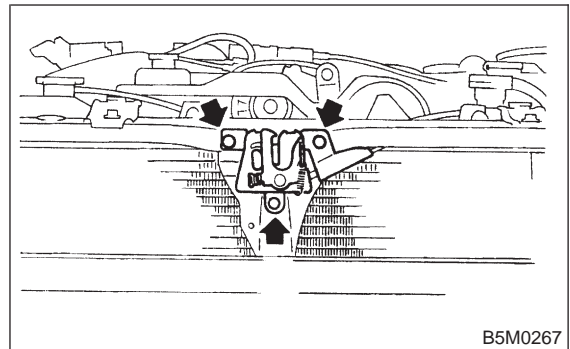

- 3) Disconnect release cable from lock assembly.
- 4) Installation is in the reverse order of removal.

NOTE:

- Route hood lock release cable and hold with clips.
- After installing release cable, ensure it operates smoothly.
- Apply grease to sliding surfaces of parts.

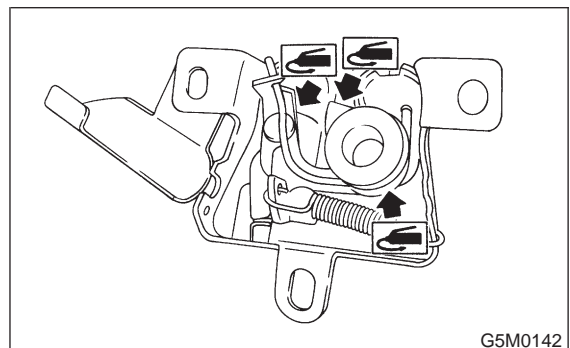

3. RELEASE CABLE

- 1) Remove front grille.
- 2) Remove release cable from opener lever in passenger compartment.
- 3) Remove release cable from lock assembly.

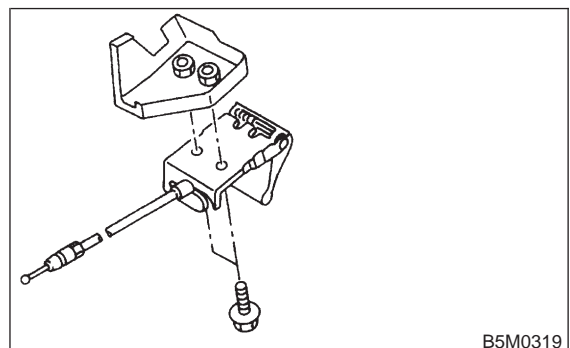

- 4) Remove cable clip from engine compartment.
- 5) Installation is in the reverse order of removal.

4. HOOD DUCT

- 1) Open front hood.
- 2) Remove attaching tapping screws and screw rivet, then remove hood inner.
- 3) Remove attaching nuts, then remove hood duct.

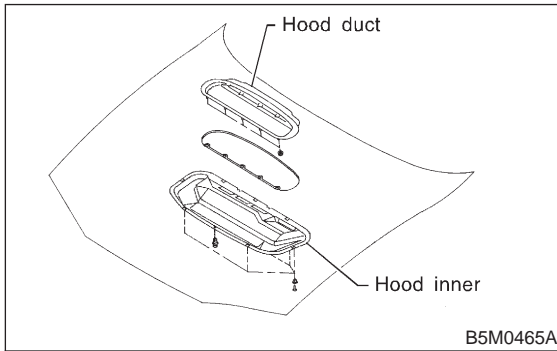

- 4) Installation is in the reverse order of removal.

B: POINTS TO CHECK

- 1) Check striker for bending or abnormal wear.
- 2) Check safety lever for improper movement.
- 3) Check other levers and spring for rust formation and unsmooth movement.

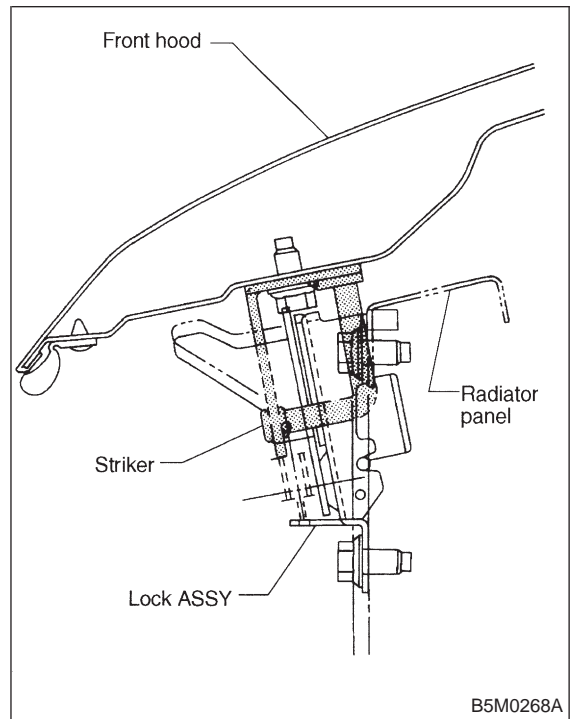
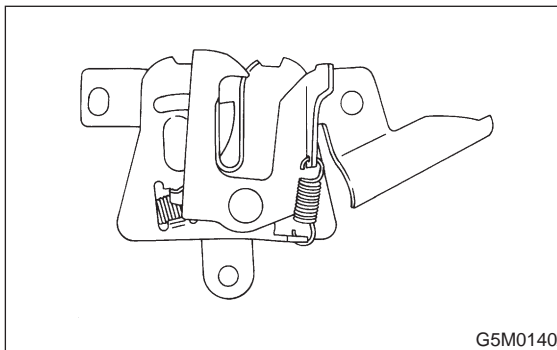

- 2) Up-down adjustment
Make up-and-down adjustment of striker only when hood does not properly contact buffer or hood is not flush with fender, or when release cable does not properly operate. Adjustment can be made by adjusting the stroke length of striker after lock assembly mounting screws are removed.

C: ADJUSTMENT

- 1) Fore-aft and left-right adjustments
Loosen striker mounting bolts and adjust fore-and-aft position of striker.

CAUTION:

Do not adjust striker position using the lock. Doing so may result in a misaligned front grille.

2. Trunk Lid

A: REMOVAL AND INSTALLATION

1. TRUNK LID

- 1) Open trunk lid.
- 2) Remove trunk lid mounting bolts and detach trunk lid from hinges.

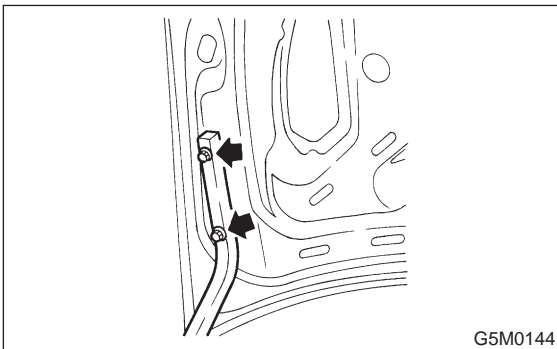

- 3) Installation is in the reverse order of removal.

2. TORSION BAR

- 1) Open trunk lid. Remove torsion bars from hinge links using ST.

ST 927780000 REMOVER

CAUTION:

Be careful because torsion bar quickly swings back when released.

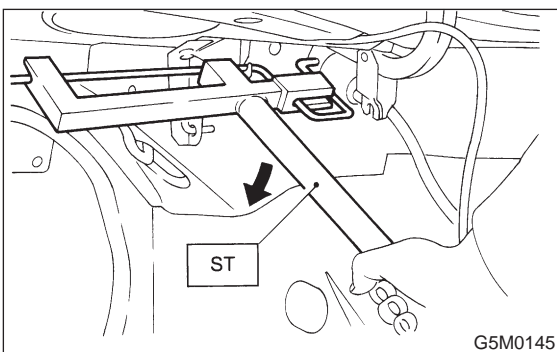

- 2) Remove the left and right torsion bars.

WARNING:

Be careful because trunk lid drops under its own weight when torsion bars are removed.

- 3) Installation is in the reverse order of removal.

NOTE:

Apply a coat of grease to the rotary section of hinges and contact surfaces of torsion bars.

3. TRUNK LID LOCK ASSEMBLY AND KEY CYLINDER

- 1) Remove rod of lock assembly from rod holder of key lock assembly.

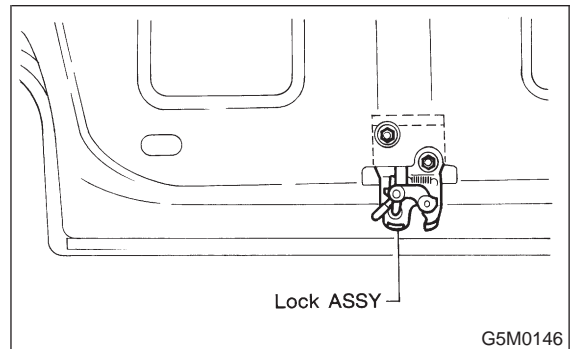

- 2) Remove nuts which hold lock assembly and remove lock assembly.

NOTE:

- Always remove rear skirt trim panel beforehand, if so equipped.
- Be careful not to bend opener cable.

- 3) Remove rod holder and detach key cylinder from trunk lid.

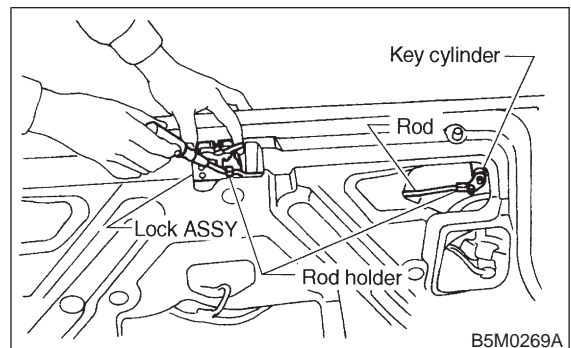

- 4) Installation is in the reverse order of removal.

NOTE:

Apply grease to sliding surfaces of lock assembly and striker.

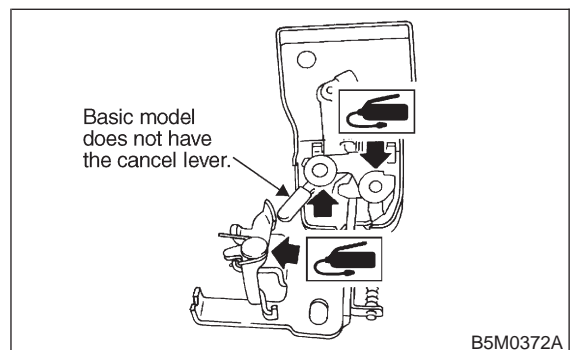

4. TRUNK LID OPENER

- 1) Remove rear seats, center pillar lower cover, floor mat, rear arch cover and side sill cover (on the driver's side).
- 2) Remove all clips which hold cable.
- 3) Disconnect cable from pull handle assembly.
- 4) Remove bolts and detach pull handle assembly.
- 5) Loosen bolts which hold lock assembly, and remove it.
- 6) Remove striker from trunk lid.

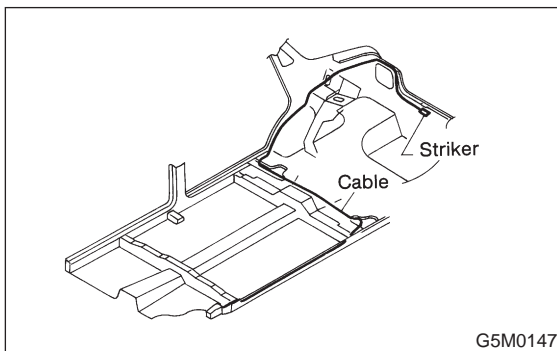

- 7) Disconnect cable from striker.

NOTE:

- Be careful not to bend or break cable.
- Basic model vehicles do not have trunk lid opener system.

- 8) Installation is in the reverse order of removal.

CAUTION:

- When installing cover to pull handle assembly, observe the following:
 - Be careful not to catch harness.
 - Engage pull handle assembly pawls firmly.

NOTE:

After installing opener cable, ensure it moves smoothly.

B: ADJUSTMENT

1. TRUNK LID

- 1) To adjust left-right lid positioning, loosen bolts which hold trunk lid to hinges.

- 2) To adjust up-down lid alignment, place washer(s) between trunk lid and hinges or move trunk lock assembly up or down.

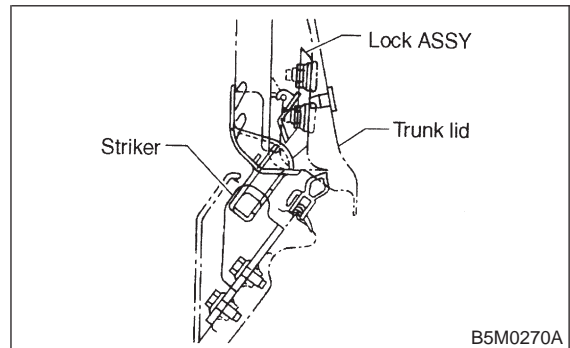

3. Fuel Flap

A: REMOVAL AND INSTALLATION

1. FUEL FLAP

- 1) Remove bolts which hold hinge to fuel flap, and detach fuel flap.

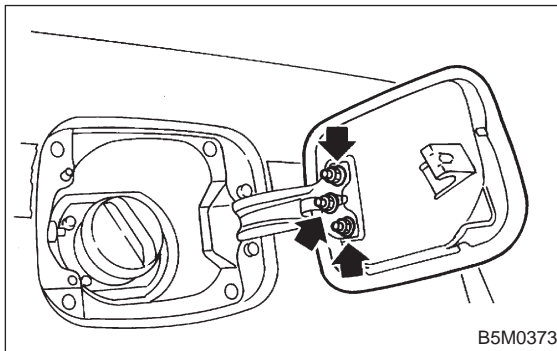

- 2) Installation is in the reverse order of removal.

CAUTION:

Make sure the clearance between fuel flap and vehicle body is equal at all points.

2. FUEL FLAP OPENER

- 1) Remove rear seats, center pillar lower cover, floor mat, rear arch cover/rear quarter trim (Wagon), and side sill cover (on the driver's side).
- 2) Remove all clips which hold cable.
- 3) Disconnect cable from pull handle.

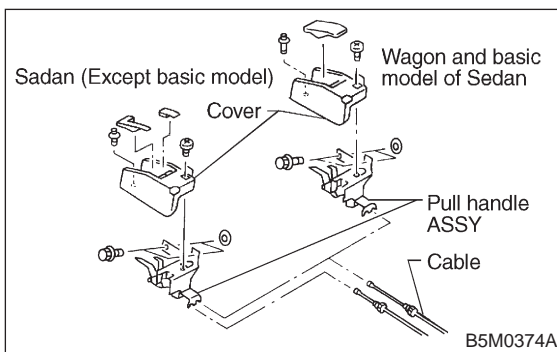

- 4) Detach pull handle by removing bolts.
- 5) Detach fuel lock holder by turning it.
- 6) Installation is in the reverse order of removal.

CAUTION:

- When installing cover to pull handle assembly, observe the following:
 - Be careful not to catch harness.
 - Engage pull handle assembly pawls firmly.
- After installing opener cable, ensure it moves smoothly.

4. Front Bumper

A: REMOVAL AND INSTALLATION

1. EXCEPT OUTBACK MODEL

- 1) Disconnect the ground cable from the battery.
- 2) Remove two bolts from lower center of bumper.

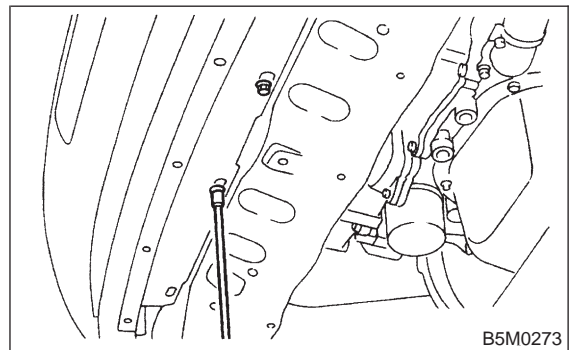

- 3) Remove mud guard. <Ref. to 5-1 [W9A1].>

NOTE:

It is not necessary to remove the entire mud guard. Remove clips from the front section of mud guard, if necessary.

- 4) Remove the canister. <Ref. to 2-1 [W3A0].>
- 5) Remove two bolts from side of bumper.

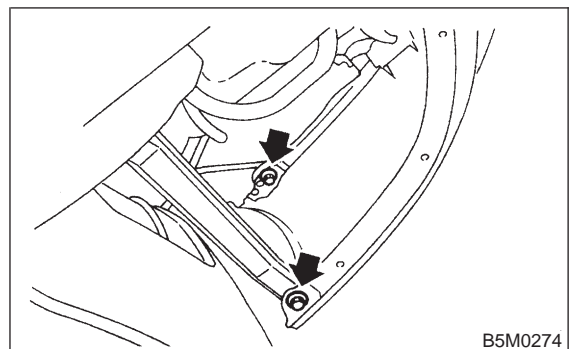

- 6) Remove front grill. <Ref. to 5-1 [W12A0].>
- 7) Remove headlight. <Ref. to 6-2 [W4B2].>
- 8) Remove clips from both sides of front bumper.

NOTE:

When removing, push the pin at the center of clip with a thin screwdriver.

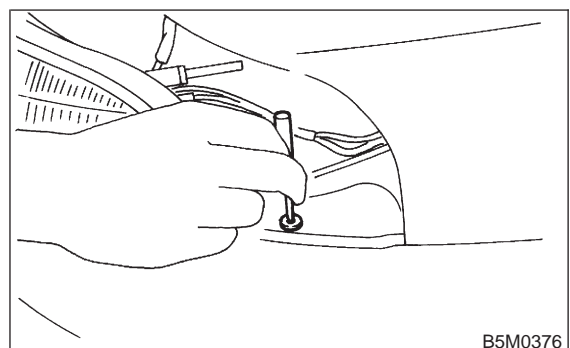

3. Fuel Flap

A: REMOVAL AND INSTALLATION

1. FUEL FLAP

- 1) Remove bolts which hold hinge to fuel flap, and detach fuel flap.

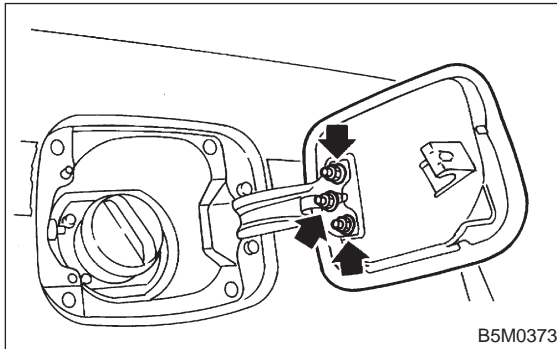

- 2) Installation is in the reverse order of removal.

CAUTION:

Make sure the clearance between fuel flap and vehicle body is equal at all points.

2. FUEL FLAP OPENER

- 1) Remove rear seats, center pillar lower cover, floor mat, rear arch cover/rear quarter trim (Wagon), and side sill cover (on the driver's side).
- 2) Remove all clips which hold cable.
- 3) Disconnect cable from pull handle.

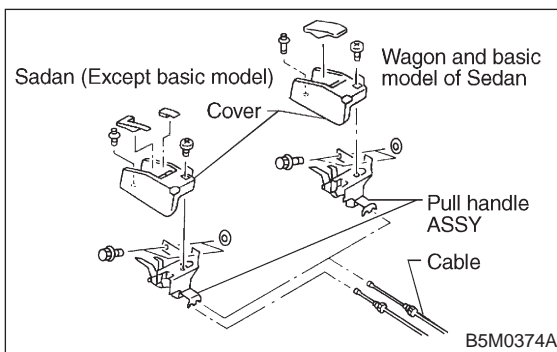

- 4) Detach pull handle by removing bolts.
- 5) Detach fuel lock holder by turning it.
- 6) Installation is in the reverse order of removal.

CAUTION:

- When installing cover to pull handle assembly, observe the following:
 - Be careful not to catch harness.
 - Engage pull handle assembly pawls firmly.
- After installing opener cable, ensure it moves smoothly.

4. Front Bumper

A: REMOVAL AND INSTALLATION

1. EXCEPT OUTBACK MODEL

- 1) Disconnect the ground cable from the battery.
- 2) Remove two bolts from lower center of bumper.

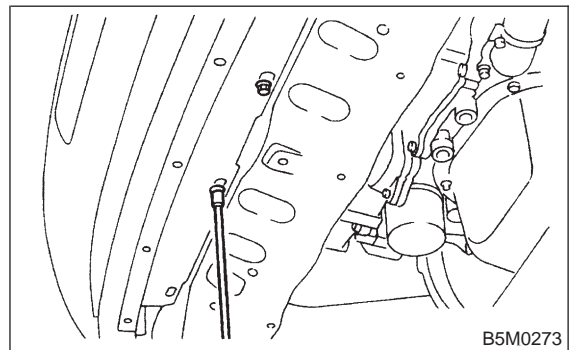

- 3) Remove mud guard. <Ref. to 5-1 [W9A1].>

NOTE:

It is not necessary to remove the entire mud guard. Remove clips from the front section of mud guard, if necessary.

- 4) Remove the canister. <Ref. to 2-1 [W3A0].>
- 5) Remove two bolts from side of bumper.

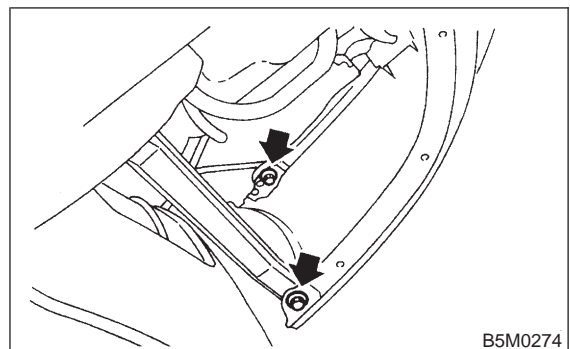

- 6) Remove front grill. <Ref. to 5-1 [W12A0].>
- 7) Remove headlight. <Ref. to 6-2 [W4B2].>
- 8) Remove clips from both sides of front bumper.

NOTE:

When removing, push the pin at the center of clip with a thin screwdriver.

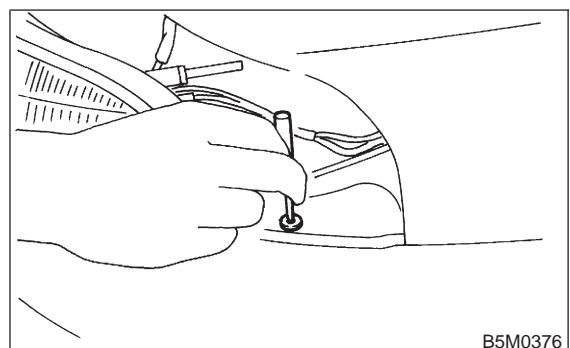

9) Remove bolts (engine compartment side) from bumper stays.

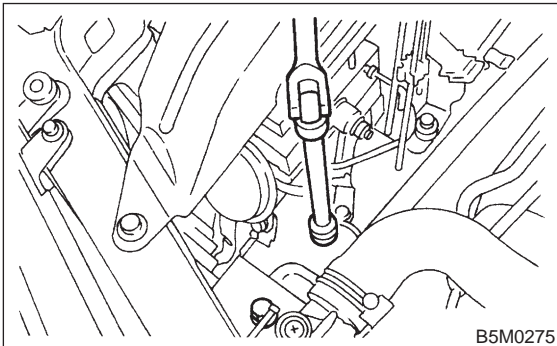

10) Remove front bumper assembly.

NOTE:

Front bumper surface is accessible for removal after removing the following parts:

Two bolts (on the lower center of bumper), mud guard, bolts (on the side of bumper), front grille, headlight, clips (on both sides of front bumper), clips (on the upper section of bumper), and clips (on the lower section of bumper).

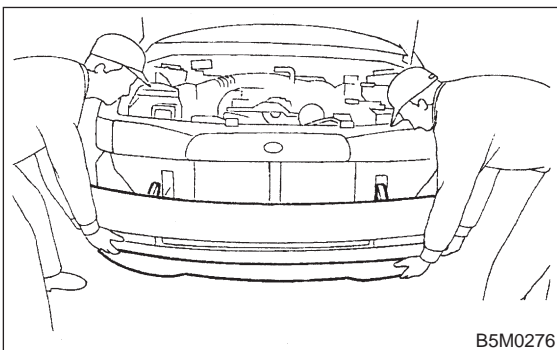

11) Installation is in the reverse order of removal.

CAUTION:

- Be extremely careful to prevent scratches on bumper face as it is made of resin.
- Be careful not to scratch the body when removing or installing the bumper.
- When installing canister, insert air vent hose of canister into the hole on body.
- To facilitate installation of front bumper, insert the protrusion inside bumper into the groove of body.

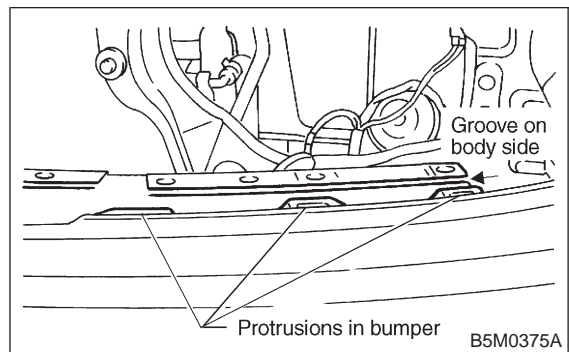

2. OUTBACK MODEL

1) Disconnect the ground cable from the battery.

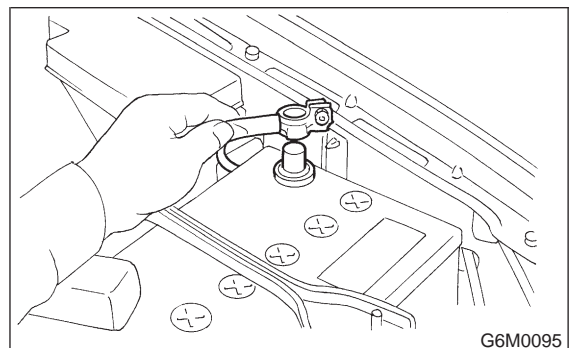

2) Remove two bolts from lower center of bumper.

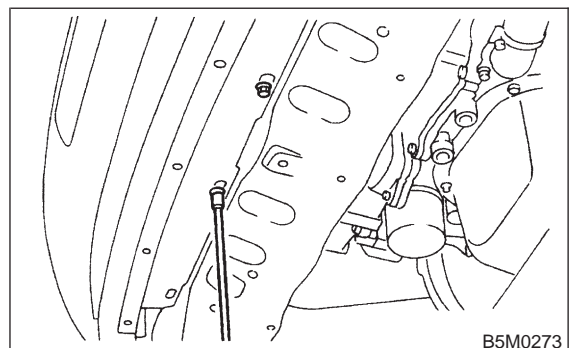

3) Remove mud guard. <Ref. to 5-1 [W9A2].>

NOTE:

It is not necessary to remove the entire mud guard. Remove clips from the front section of mud guard, if necessary.

4) Remove the canister. <Ref. to 2-1 [W3A0].>

5-1 [W4A2]
4. Front Bumper

SERVICE PROCEDURE

5) Remove two bolts from side of bumper.

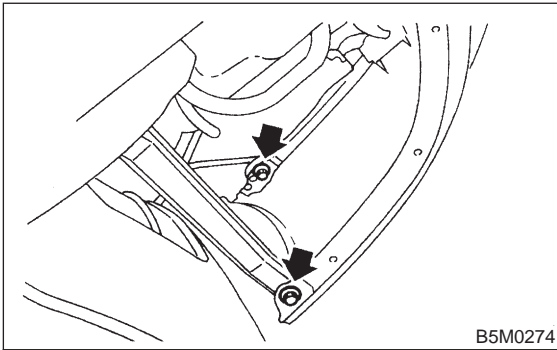

- 6) Remove front grill. <Ref. to 5-1 [W12A0].>
- 7) Remove headlight. <Ref. to 6-2 [W4B2].>
- 8) Remove fog lamps.
- 9) Remove clips from both sides of front bumper.

NOTE:

When removing, push the pin at the center of clip with a thin screwdriver.

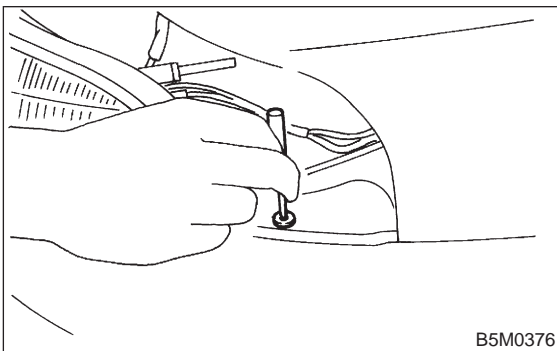

10) Remove bolts (engine compartment side) from bumper stays.

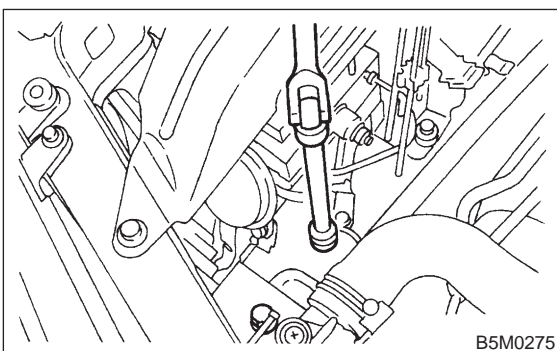

11) Remove front bumper assembly.

NOTE:

Front bumper surface is accessible for removal after removing the following parts:

Two bolts (on the lower center of bumper), mud guard, bolts (on the side of bumper), front grille, headlight, clips (on both sides of front bumper), clips (on the upper section of bumper), and clips (on the lower section of bumper).

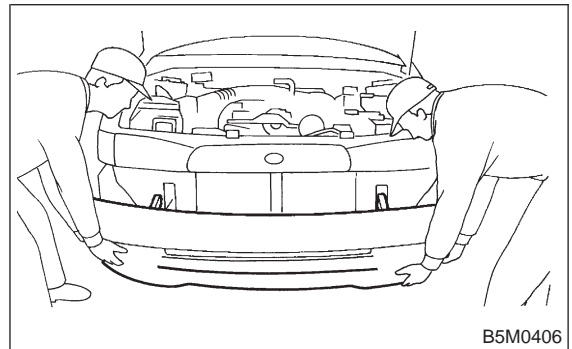

12) Installation is in the reverse order of removal.

CAUTION:

- Be extremely careful to prevent scratches on bumper face as it is made of resin.
- Be careful not to scratch the body when removing or installing the bumper.
- When installing canister, insert air vent hose of canister into the hole on body.
- To facilitate installation of front bumper, insert the protrusion inside bumper into the groove of body.

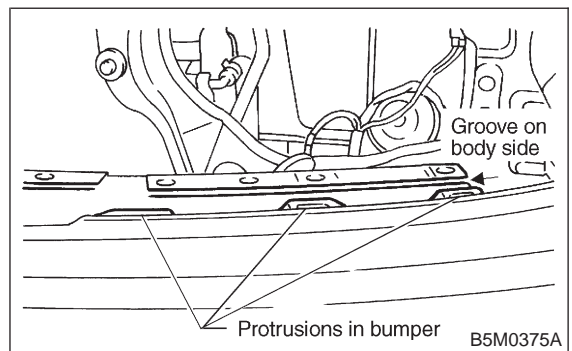

5. Rear Bumper

A: REMOVAL AND INSTALLATION

1. SEDAN

1) Remove one bolt and one clip from side of bumper.

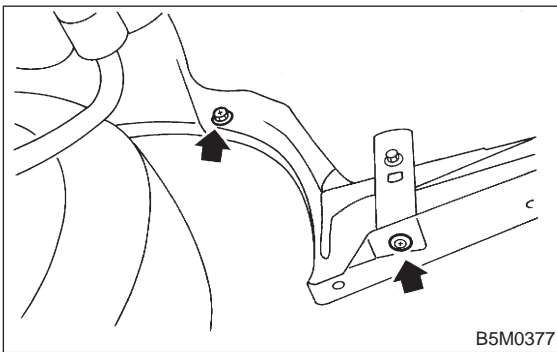

2) Open trunk lid. Remove trunk trim panel clips and detach trim.

3) Remove rear bumper beam (upper) attaching nut.

4) Remove bolts from bumper stays.

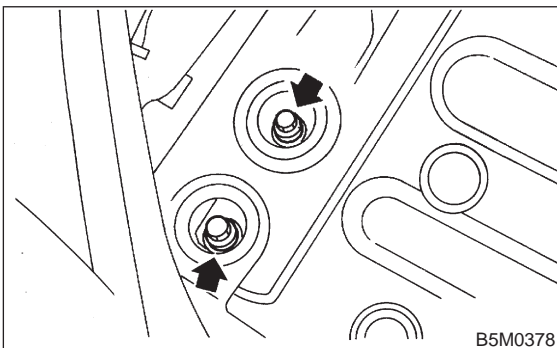

5) Remove rear bumper assembly.

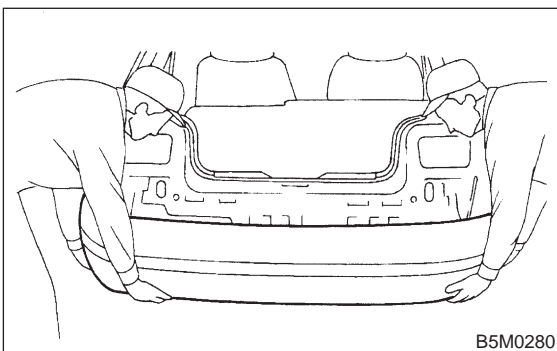

6) Installation is in the reverse order of removal.

CAUTION:

- Be extremely careful to prevent scratches on bumper face as it is made of resin.
- Be careful not to scratch the body when removing or installing bumper.

● To facilitate installation of rear bumper, attach slider to the guide pin.

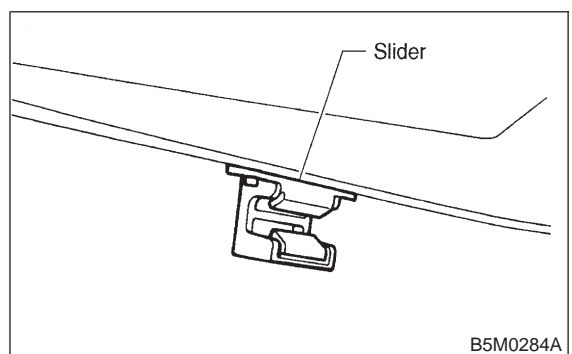
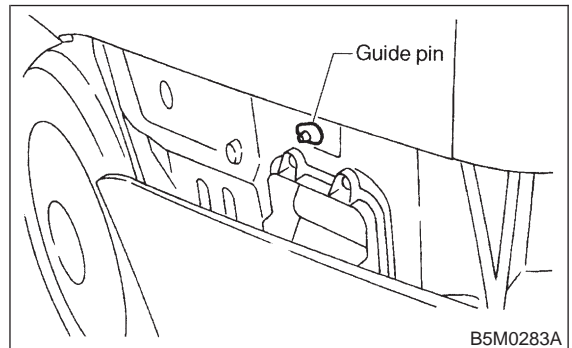

● To facilitate installation of rear bumper, insert the bumper hook into the body groove.

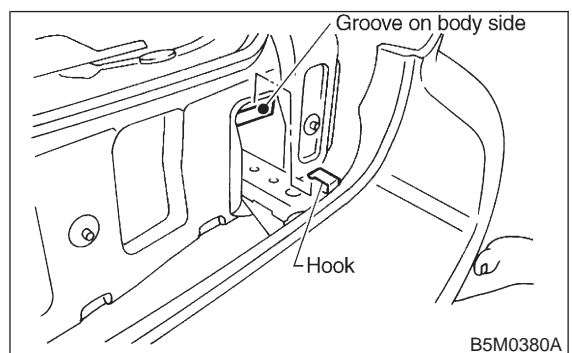

2. WAGON

1) Remove one bolt and one clip from side of bumper.

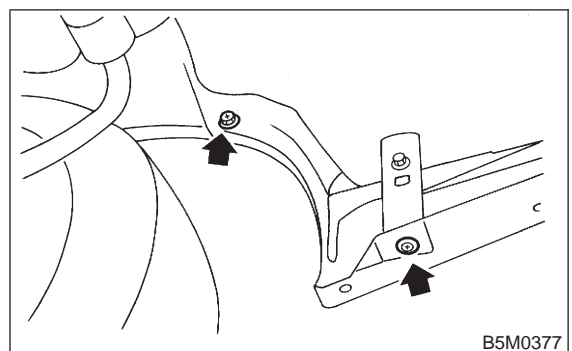

2) Open rear gate. Remove rear quarter trim lid.

3) Remove two clips from lower center of bumper.

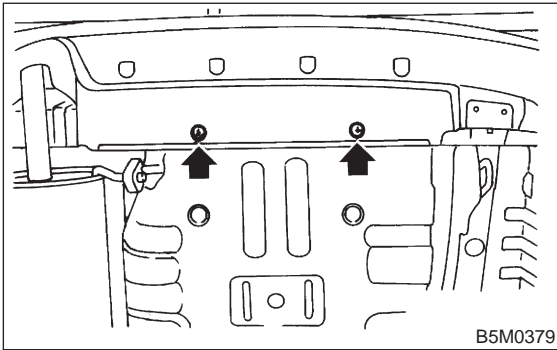

4) Remove bolts from bumper stays.

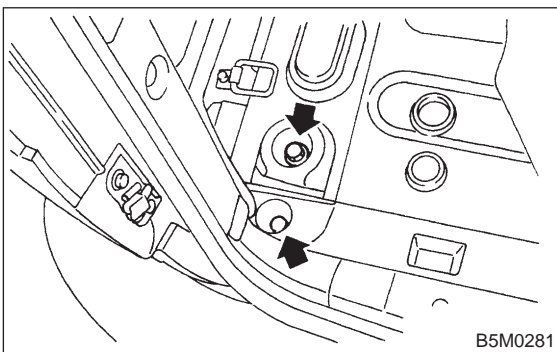

5) Remove rear bumper assembly.

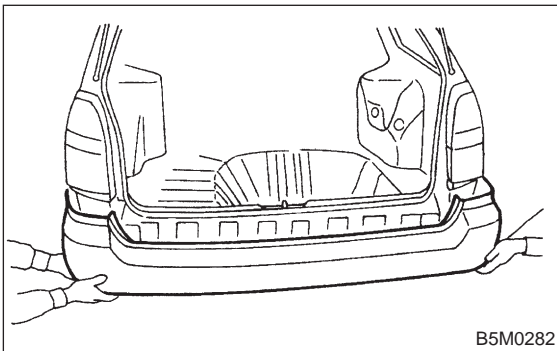

6) Installation is in the reverse order of removal.

CAUTION:

- Be extremely careful to prevent scratches on bumper face as it is made of resin.
- Be careful not to scratch the body when removing or installing bumper.

● To facilitate installation of rear bumper, attach slider to the guide pin.

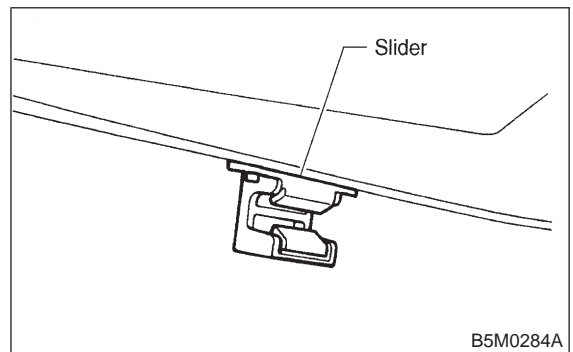
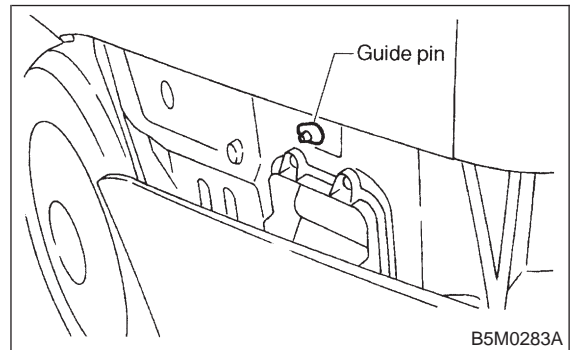

● To facilitate installation of rear bumper, insert the bumper hook into the body groove.

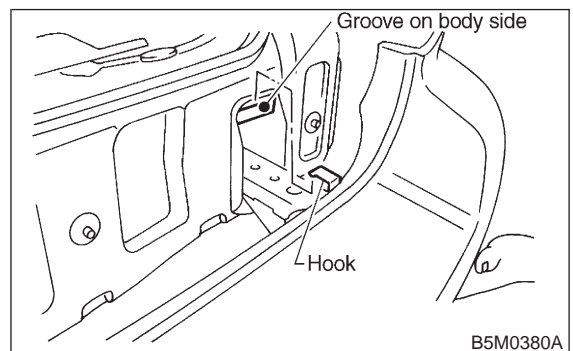

3. OUTBACK MODEL

1) Remove one clip from side of bumper.

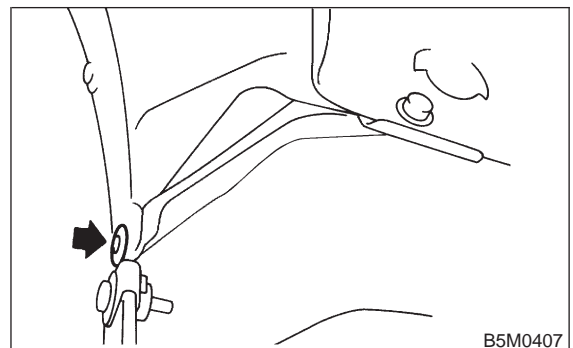

2) Open rear gate and remove rear quarter trim lid.

3) Remove five bolts from lower center of bumper.

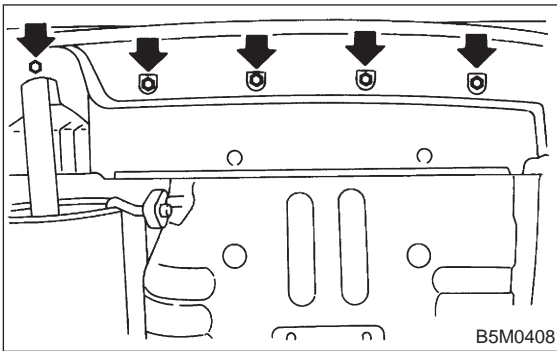

4) Remove bolts from bumper stays.

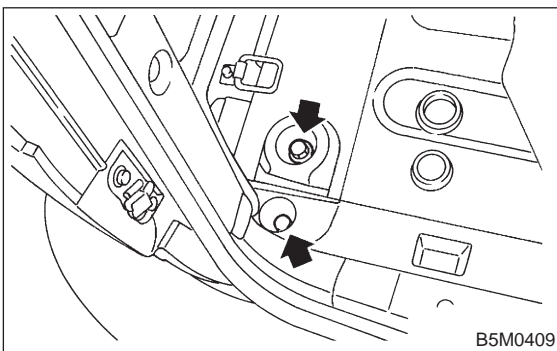

5) Remove rear bumper assembly.

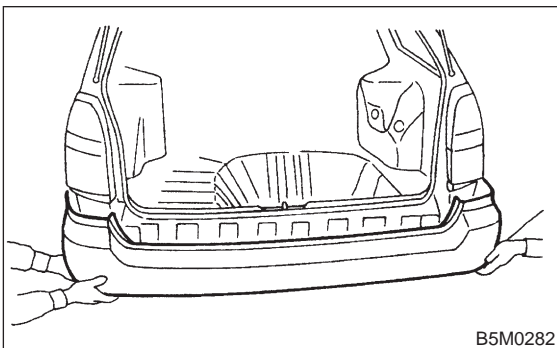

6) Installation is in the reverse order of removal.

CAUTION:

- Be extremely careful to prevent scratches on bumper face as it is made of resin.
- Be careful not to scratch the body when removing or installing bumper.

● To facilitate installation of rear bumper, attach slider to the guide pin.

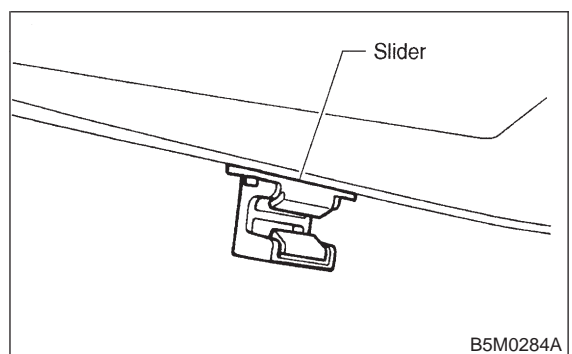
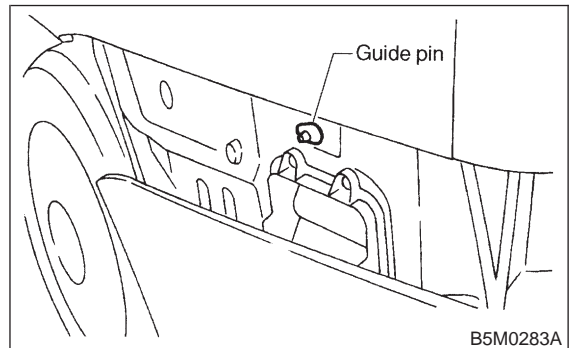

● To facilitate installation of rear bumper, insert the bumper hook into the body groove.

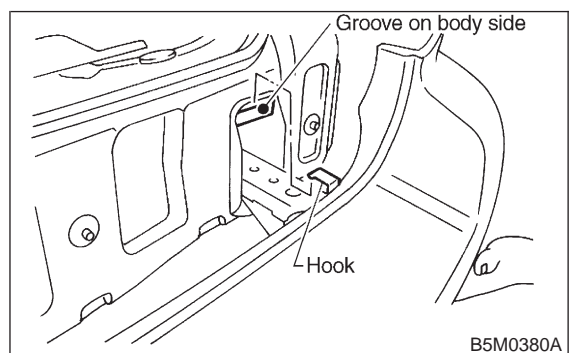

6. Coating Method for PP Bumper

A: PROCESS STEPS

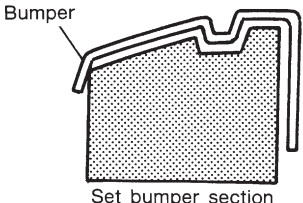
Process No.	Process name	Job contents	
1	Bumper mounting	Set bumper on paint work table if required. Use paint work table conforming to inner shape of bumper when possible.	 <p style="text-align: right;">G5M0164</p>
2	Masking	Mask specified part (black base) with masking tape. Use masking tape for PP (e.g., Nichiban No. 533, etc.).	
3	Degreasing, cleaning	Clean all parts to be painted with white gasoline, normal alcohol, etc. to remove dirt, oil, fat, etc.	
4	Primer paint	First, apply one coat of primer to all parts to be painted, using air gun. Use primer (clear).	
5	Drying	Dry at normal temperature [10 to 15 min. at 20°C (68°F)]. In half-dried condition, PP primer paint is dissolved by solvent, e.g. thinner, etc. Therefore, if dust or dirt must be removed, use ordinary alcohol, etc.	
6	Top coat paint (I)	Solid color	Metallic color
		Use section (block) paint for top coat. <ul style="list-style-type: none"> ● Paint in use (for each color): Solid paint Hardener PB Thinner T-301 ● Mixing ratio: Main agent vs. hardener = 4:1 ● Viscosity: 10 — 13 sec/20°C (68°F) ● Film thickness: 35 — 45μ ● Spraying pressure: 245 — 343 kPa (2.5 — 3.5 kg/cm², 36 — 50 psi) 	Use section (block) paint for top coat. <ul style="list-style-type: none"> ● Paint in use (for each color): Metallic paint Hardener PB Thinner T-306 ● Mixing ratio: Main agent vs. hardener = 10:1 ● Viscosity: 10 — 13 sec/20°C (68°F) ● Film thickness: 15 — 20μ ● Spraying pressure: 245 — 343 kPa (2.5 — 3.5 kg/cm², 36 — 50 psi)
7	Drying	Not required.	Dry at normal temperature [10 min. or more at 20°C (68°F)]. In half-dried condition, avoid dust, dirt.
8	Top coat paint (II)	Not required.	Apply a clear coat to parts with top coat paint (I), three times, at 5 — 7 minutes intervals. <ul style="list-style-type: none"> ● Paint in use: Metallic paint Hardener PB Thinner T-301 ● Mixing ratio: Clear vs. hardener = 6:1 ● Viscosity: 14 — 16 sec/20°C (68°F) ● Film thickness: 25 — 30μ ● Spraying pressure: 245 — 343 kPa (2.5 — 3.5 kg/cm², 36 — 50 psi)
9	Drying	60°C (140°F), 60 min. or 80°C (176°F), 30 min. If higher than 80°C (176°F), PP may be deformed. Keep maximum temperature of 80°C (176°F).	
10	Inspection	Paint check	
11	Masking removal	Remove masking in process No. 2.	

7. Repair Instructions for Colored PP Bumper

All PP bumpers are provided with a grained surface, and if the surface is damaged, it cannot normally be restored to its former condition. Damage limited to shallow scratches that cause only a

change in the lustre of the base material or coating, can be almost fully restored. Before repairing a damaged area, explain this point to the customer and get an understanding about the matter.

Repair methods are outlined below, based on a classification of the extent of damage.

A: MINOR DAMAGE CAUSING ONLY A CHANGE IN THE LUSTRE OF THE BUMPER DUE TO A LIGHT TOUCH

It is almost restorable as follows:

Process No.	Process name	Job contents	
1	Cleaning	Clean the area to be repaired using water.	
2	Sanding	Grind the repairing area with #500 sand paper in a "feathering" motion.	
3	Finish	Resin section	Coated section
		Repeatedly apply wax to the affected area using a soft cloth (such as flannel). Recommended wax: NITTO KASEI Soft 99 TIRE WAX BLACK, or equivalent.	Perform either the same operation as for the resin section or process No. 18 and subsequent operations in the "3." section, depending on the degree and nature of damage. Polish the waxed area with a clean cloth after 5 to 10 minutes.
		Polish the waxed area with a clean cloth after 5 to 10 minutes.	

B: DEEP DAMAGE CAUSED BY SCRATCHING FENCES, ETC.

A dent cannot be repaired but a whitened or swelled part can be removed.

Process No.	Process name	Job contents	
1	Cleaning	Clean damaged area with water.	
2	Removal of damaged area	Cut off protruding area, if any, due to collision, using a putty knife.	
3	Sanding	Grind the affected area with #100 to #500 sand paper.	
4	Finish	Resin section	Coated section
		Same as process No. 3 in the "1." section.	Perform process No. 12 and subsequent operations in the "3." section.

C: DEEP DAMAGE SUCH AS A BREAK OR HOLE THAT REQUIRES FILLING

Much of the peripheral grained surface must be sacrificed for repair, and the degree of restoration is not really worth the expense. (The surface, however, will become almost flush with adjacent areas.)

Recommended repair kit: PP Part Repair Kit (NRM)

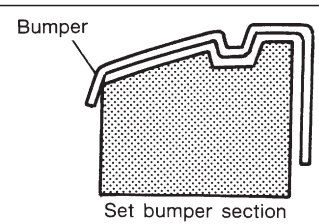
Process No.	Process name	Job contents	
1	Bumper removal	Remove bumper as required.	
2	Parts removal	Place bumper on a paint work table as required.	
3	Bumper placement	Place bumper on a paint work table as required. It is recommended that contour of work table accommodates internal shape of bumper.	
4	Surface preparation	Remove dust, oil, etc. from areas to be repaired and surrounding areas, using a suitable solvent (NRM No. 900 precleno, white gasoline, or alcohol).	

G5M0164

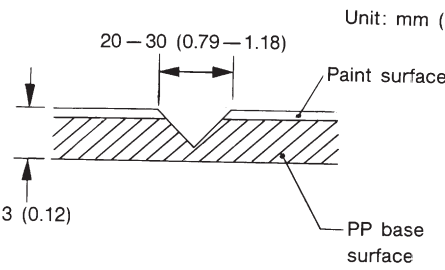
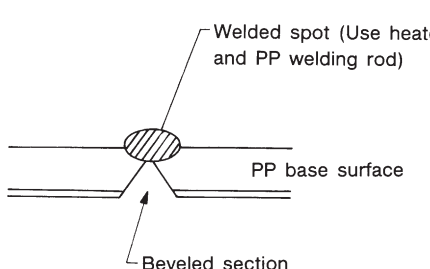
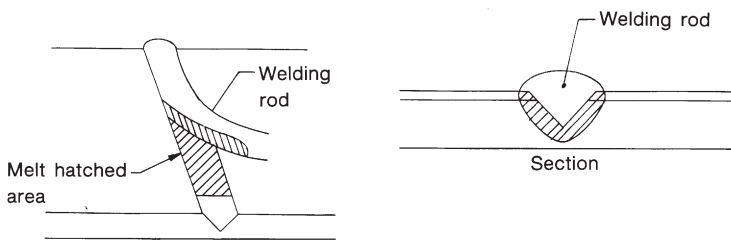
Process No.	Process name	Job contents	
5	Cutting	<p>If nature of damage are cracks or holes, cut a guide slit of 20 to 30 mm (0.79 to 1.18 in) in length along the crack or hole up to the bumper's base surface. Then, bevel or "vee- out" the affected area using a knife or grinder.</p>	 <p style="text-align: right;">Unit: mm (in)</p> <p style="text-align: right;">G5M0165</p>
6	Sanding (I)	Grind beveled surface with sand paper (#40 to #60) to smooth finish.	
7	Cleaning	Clean the sanded surface with the same solvent as used in process No. 4.	
8	Temporary welding	<p>Grind the side just opposite the beveled area with sand paper (#40 to #60) and clean using a solvent. Temporarily spot-weld the side, using a PP welding rod and heater gun.</p>	 <p style="text-align: right;">G5M0166</p>
		<p>NOTE:</p> <ul style="list-style-type: none"> ● Do not melt welding rod until it flows out. This results in reduced strength. ● Leave the welded spot unattended until it cools completely. 	
9	Welding	<p>Using a heater gun and PP welding rod, weld the beveled spot while melting the rod and damaged area.</p>	 <p style="text-align: right;">G5M0167</p>
		<p>NOTE:</p> <ul style="list-style-type: none"> ● Melt the sections indicated by hatched area. ● Do not melt welding rod until it flows out, in order to provide strength. ● Always keep the heater gun 1 to 2 cm (0.4 to 0.8 in) away from the welding spot. ● Leave the welded spot unattended until it cools completely. 	

SERVICE PROCEDURE

[W7C0] 5-1

7. Repair Instructions for Colored PP Bumper

Process No.	Process name	Job contents
10	Sanding (II)	Remove excess part of weld with a putty knife. If a drill or disc wheel is used instead of the knife, operate it at a rate lower than 1,500 rpm and grind the excess part little by little. A higher rpm will cause the PP substrate to melt from the heat.
		 <p style="text-align: right;">G5M0168</p>
		Sand the welded spot smooth with #240 sand paper.
11	Masking	Mask the black substrate section using masking tape. Recommended masking tape: Nichiban No. 533 or equivalent
12	Cleaning/ degreasing	Completely clean the entire coated area, using solvent similar to that used in process No. 4.
13	Primer coating	Apply a coat of primer to the repaired surface and its surrounding areas. Mask these areas, if necessary. Recommended primer: Mp/ 364 PP primer NOTE: Be sure to apply one coat of primer at a spraying pressure of 245 to 343 kPa (2.5 to 3.5 kg/cm ² , 36 to 50 psi) with a spray gun.
14	Leave unattended.	Leave the repaired area unattended at 20°C (68°F) for 10 to 15 minutes until primer is half-dry. NOTE: If dirt or dust comes in contact with the coated area, wipe it off with a cloth dampened with alcohol. (Do not use thinner since the coated area tends to melt.)
15	Primer surfacer coating	Apply a coat of primer surfacer to the repaired area two or three times at an interval of 3 to 5 minutes. Recommended surfacer: <ul style="list-style-type: none"> ● UPS 300 Flex primer ● No. 303 UPS 300 Exclusive hardener ● NPS 725 Exclusive reducer (thinner) ● Mixing ratio: 2 : 1 (UPS 300: No. 303) ● Viscosity: 12 — 14 sec/20°C (68°F) ● Coated film thickness: 40 — 50μ
16	Drying	Allow the coated surface to dry for 60 minutes at 20°C (68°F) [or 30 minutes at 60°C (140°F)].
17	Sanding (III)	Sand the coated surface and its surrounding areas using #400 sand paper and water.
18	Cleaning/ degreasing	Same as process No. 12.
19	Top coat	Solid color
		Use a “block” coating method. <ul style="list-style-type: none"> ● Recommended paint: Suncryl (SC) ● No. 307 Flex hardener ● SC reducer (thinner) ● Mixing ratio: 3 : 1 ● Suncryl (SC) vs. No. 307 Flex hardener ● Viscosity: 11 — 13 sec/20°C (68°F) ● Coated film thickness: 40 — 50μ ● Spraying thickness: 245 — 343 kPa (2.5 — 3.5 kg/cm², 36 — 50 psi)
		Metallic color
		Use a “block” coating method. <ul style="list-style-type: none"> ● Recommended paint: Suncryl (SC) ● No. 307 Flex hardener ● SC Reducer (thinner) ● Mixing ratio: 3 : 1 ● Suncryl (SC) vs. No. 307 Flex Hardener ● Viscosity: 11 — 13 sec/20°C (68°F) ● Coated film thickness: 20 — 30μ ● Spraying thickness: 245 — 343 kPa (2.5 — 3.5 kg/cm², 36 — 50 psi)
20	Leave unattended.	Not required. Leave unattended at 20°C (68°F) for at least 10 minutes until the top coated area is half-dry. NOTE: Be careful to keep dust or dirt from coming in contact with the affected area.

Process No.	Process name	Job contents
21	Top coat (II)	Not required. Apply a clear coat three times at an interval of 3 to 5 minutes. ● Recommended paint: Suncryl (SC) No. 307 Flex hardener SC Reducer (thinner) ● Mixing ratio: 3 : 1 Suncryl (SC) vs. No. 307 Flex Hardener ● Viscosity: 11 — 13 sec/20°C (68°F) ● Coated film thickness: 20 — 30μ ● Spraying thickness: 245 — 343 kPa (2.5 — 3.5 kg/cm ² , 36 — 50 psi)
22	Drying	Allow the coated surface to dry at 20°C (68°F) for two hours or 60°C (140°F) for 30 minutes. NOTE: Do not allow the temperature to exceed 80°C (176°F) since this will deform the PP substrate.
23	Inspection	Carefully check the condition of the repaired area.
24	Masking removal	Remove masking tape applied in process No. 11 and 13.
25	Parts installation	Install parts on bumper in reverse order of removal.
26	Bumper installation	Install bumper.

8. Front Fender

A: REMOVAL AND INSTALLATION

- 1) Disconnect ground cable from battery.
- 2) Remove bracket which secures mud guard to front fender.

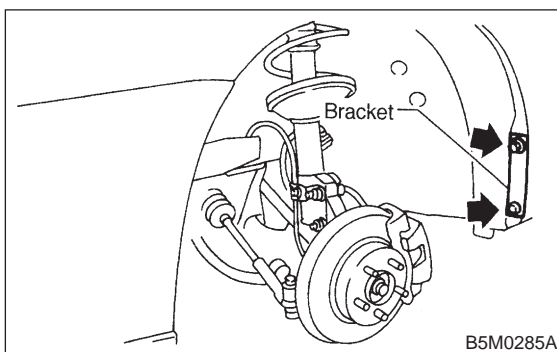

- 3) Remove mud guard. <Ref. to 5-1 [W9A1].> and <Ref. to 5-1 [W9A2].>

NOTE:

Do not remove the entire mud guard, only the front section of it.

- 4) Remove headlight. <Ref. to 6-2 [W4B2].>

- 5) Remove bolts which secure front fender. Remove front fender.

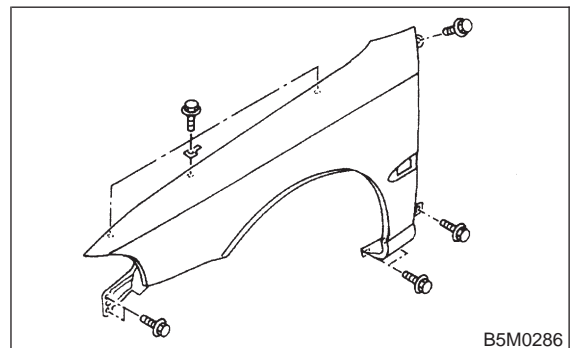

Process No.	Process name	Job contents
21	Top coat (II)	Not required. Apply a clear coat three times at an interval of 3 to 5 minutes. ● Recommended paint: Suncryl (SC) No. 307 Flex hardener SC Reducer (thinner) ● Mixing ratio: 3 : 1 Suncryl (SC) vs. No. 307 Flex Hardener ● Viscosity: 11 — 13 sec/20°C (68°F) ● Coated film thickness: 20 — 30μ ● Spraying thickness: 245 — 343 kPa (2.5 — 3.5 kg/cm ² , 36 — 50 psi)
22	Drying	Allow the coated surface to dry at 20°C (68°F) for two hours or 60°C (140°F) for 30 minutes. NOTE: Do not allow the temperature to exceed 80°C (176°F) since this will deform the PP substrate.
23	Inspection	Carefully check the condition of the repaired area.
24	Masking removal	Remove masking tape applied in process No. 11 and 13.
25	Parts installation	Install parts on bumper in reverse order of removal.
26	Bumper installation	Install bumper.

8. Front Fender

A: REMOVAL AND INSTALLATION

- 1) Disconnect ground cable from battery.
- 2) Remove bracket which secures mud guard to front fender.

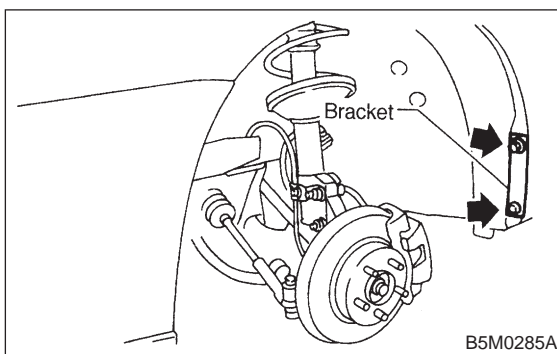

- 3) Remove mud guard. <Ref. to 5-1 [W9A1].> and <Ref. to 5-1 [W9A2].>

NOTE:

Do not remove the entire mud guard, only the front section of it.

- 4) Remove headlight. <Ref. to 6-2 [W4B2].>

- 5) Remove bolts which secure front fender. Remove front fender.

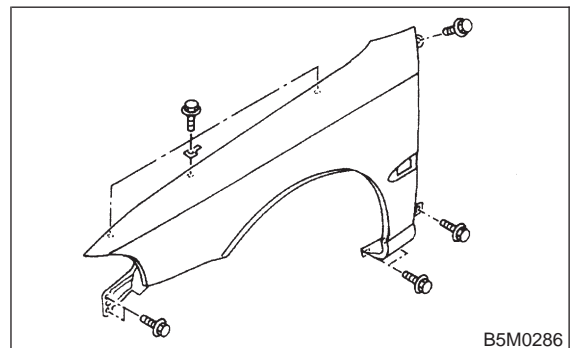

6) Installation is in the reverse order of removal.

NOTE:

Check for alignment of front fender with hood and front door with front fender at all points. Adjust, if necessary.

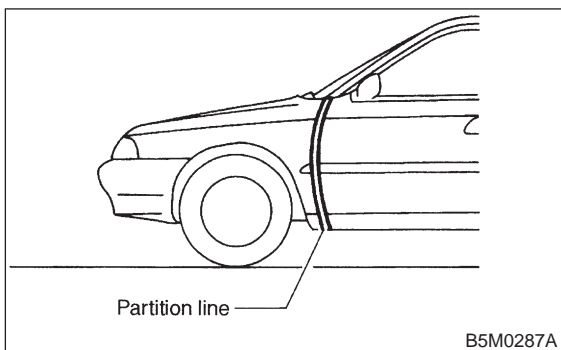
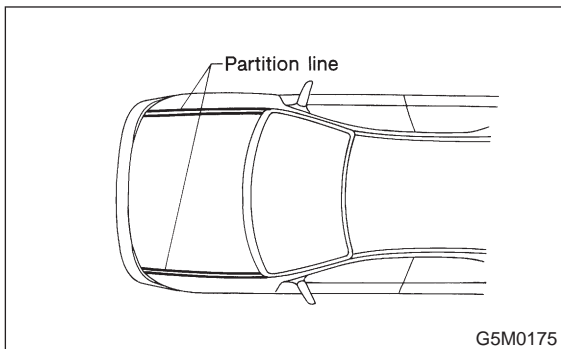

9. Mud Guard and Rear Arch Protector

A: REMOVAL AND INSTALLATION

1. MUD GUARD (EXCEPT OUTBACK MODEL)

- 1) Jack-up vehicle to remove tire.
- 2) Remove screws and clips. Move mud guard toward the center of the body and remove mud guard.

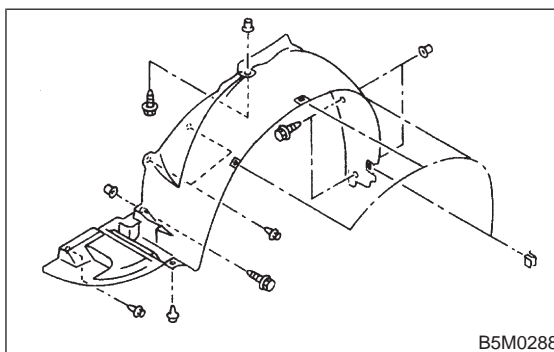

3) Installation is in the reverse order of removal.

CAUTION:

Only use new screws and clips.

2. MUD GUARD (OUTBACK MODEL)

- 1) Jack-up vehicle to remove tire.
- 2) Remove screws and clips. Move mud guard toward the center of the body and remove mud guard.

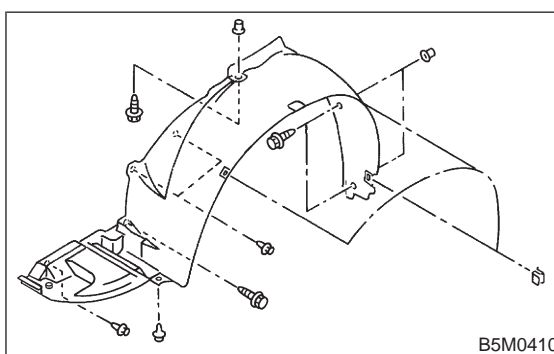

3) Installation is in the reverse order of removal.

CAUTION:

Only use new screws and clips.

6) Installation is in the reverse order of removal.

NOTE:

Check for alignment of front fender with hood and front door with front fender at all points. Adjust, if necessary.

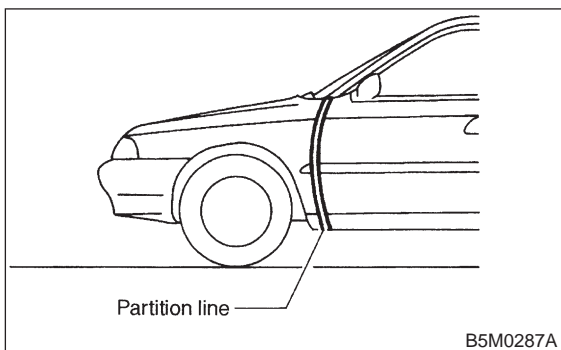
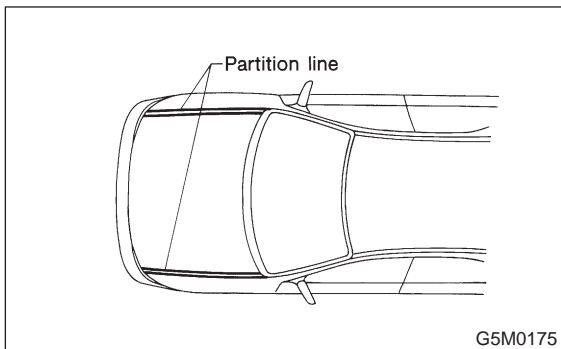

9. Mud Guard and Rear Arch Protector

A: REMOVAL AND INSTALLATION

1. MUD GUARD (EXCEPT OUTBACK MODEL)

- 1) Jack-up vehicle to remove tire.
- 2) Remove screws and clips. Move mud guard toward the center of the body and remove mud guard.

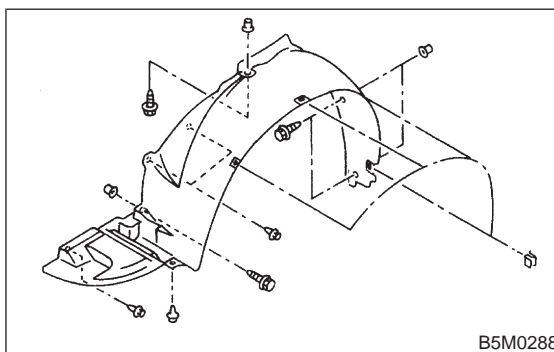

3) Installation is in the reverse order of removal.

CAUTION:

Only use new screws and clips.

2. MUD GUARD (OUTBACK MODEL)

- 1) Jack-up vehicle to remove tire.
- 2) Remove screws and clips. Move mud guard toward the center of the body and remove mud guard.

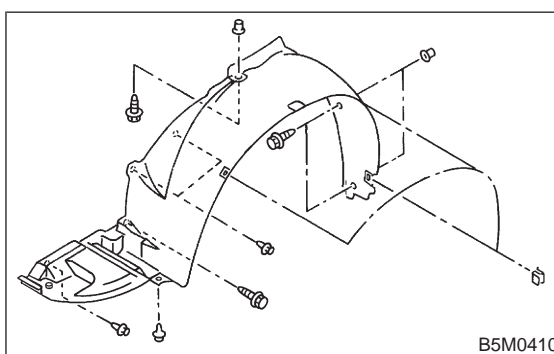

3) Installation is in the reverse order of removal.

CAUTION:

Only use new screws and clips.

3. REAR ARCH PROTECTOR

- 1) Remove rear arch protector.

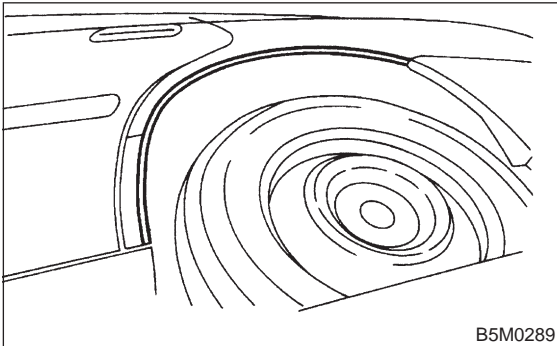

- 2) Installation is in the reverse order of removal.

CAUTION:

Only use new screws and clips.

10. Cowl Panel

A: REMOVAL AND INSTALLATION

- 1) Remove wiper arms.
- 2) Open front hood.
- 3) Remove cowl panel seal using a plier.

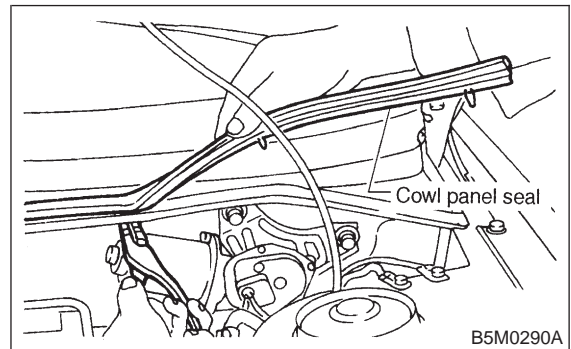

- 4) Lift cowl panel and detach it from clips attached to body panel.

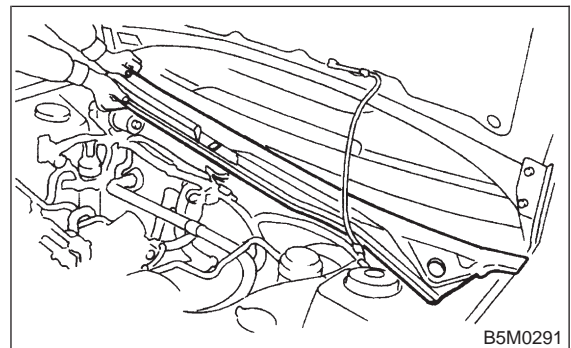

- 5) Installation is in the reverse order of removal.

NOTE:

When installing cowl panel, first attach a middle clip to the cap attached to body panel. Then tap the cowl panel to attach it to other clips.

3. REAR ARCH PROTECTOR

- 1) Remove rear arch protector.

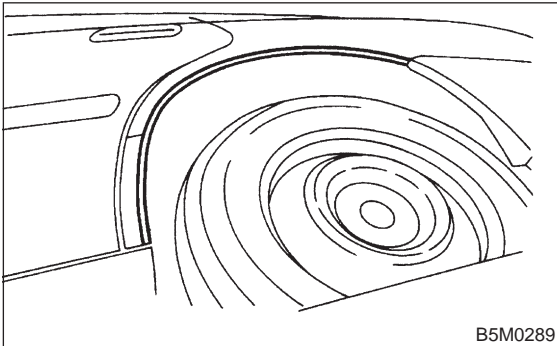

- 2) Installation is in the reverse order of removal.

CAUTION:

Only use new screws and clips.

10. Cowl Panel

A: REMOVAL AND INSTALLATION

- 1) Remove wiper arms.
- 2) Open front hood.
- 3) Remove cowl panel seal using a plier.

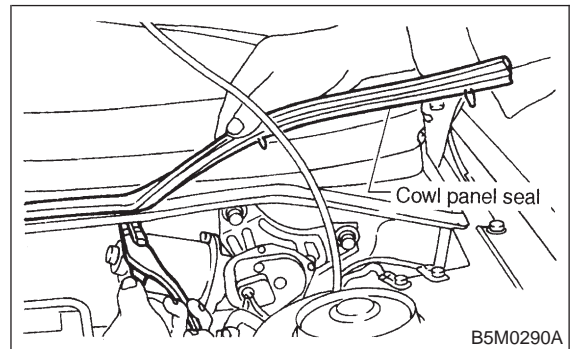

- 4) Lift cowl panel and detach it from clips attached to body panel.

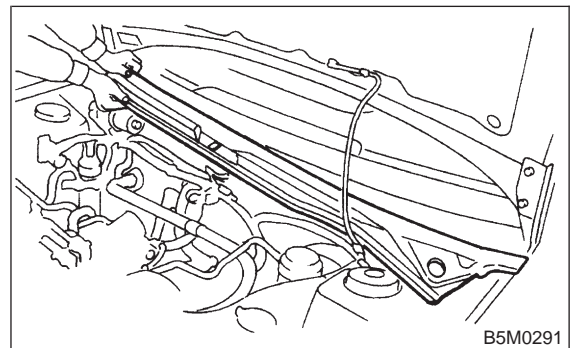

- 5) Installation is in the reverse order of removal.

NOTE:

When installing cowl panel, first attach a middle clip to the cap attached to body panel. Then tap the cowl panel to attach it to other clips.

11. Molding and Retainer

A: REMOVAL AND INSTALLATION

- 1) Remove weatherstrip.
- 2) Remove tapping screws.

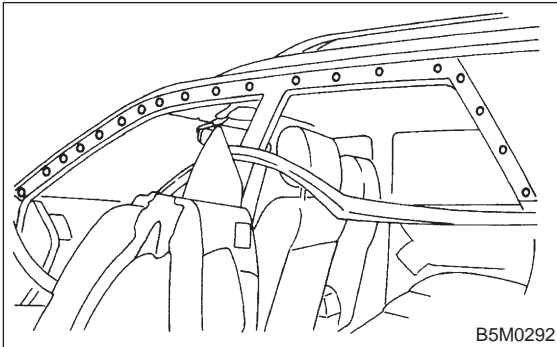

- 3) Installation is in the reverse order of removal.

NOTE:

Insert molding and retainer onto hook, then fasten with screws. Insert molding and retainer onto hook, then fasten with screws.

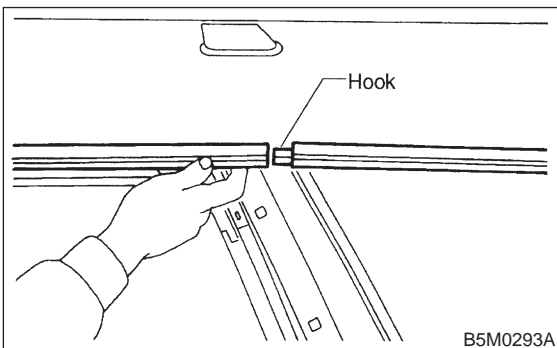

12. Front Grille

A: REMOVAL AND INSTALLATION

- 1) Remove four upper clips from body panel. To facilitate removal, press portion shown in figure using screwdriver.

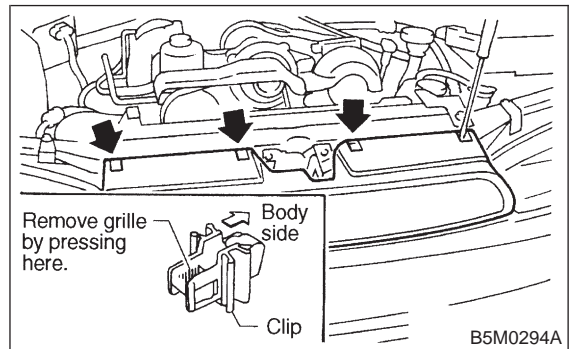

- 2) Pull front grille to detach it from two lower clips. (Two lower clips remain on headlight.)
- 3) Installation is in the reverse order of removal.

NOTE:

Attach all clips to grille. Align them with clip hole in body and push them into place.

11. Molding and Retainer

A: REMOVAL AND INSTALLATION

- 1) Remove weatherstrip.
- 2) Remove tapping screws.

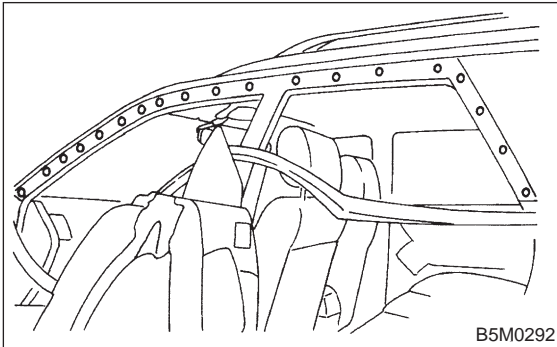

- 3) Installation is in the reverse order of removal.

NOTE:

Insert molding and retainer onto hook, then fasten with screws. Insert molding and retainer onto hook, then fasten with screws.

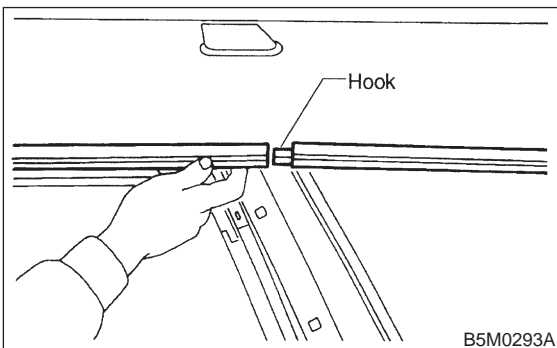

12. Front Grille

A: REMOVAL AND INSTALLATION

- 1) Remove four upper clips from body panel. To facilitate removal, press portion shown in figure using screwdriver.

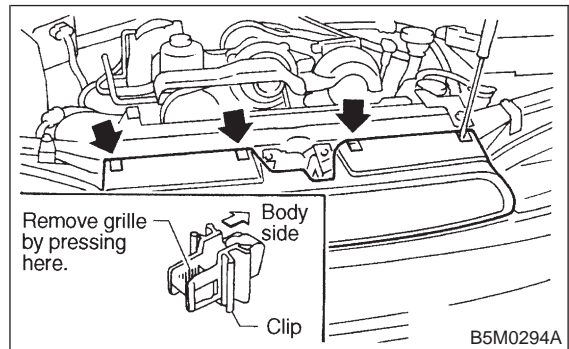

- 2) Pull front grille to detach it from two lower clips. (Two lower clips remain on headlight.)
- 3) Installation is in the reverse order of removal.

NOTE:

Attach all clips to grille. Align them with clip hole in body and push them into place.

13. Door Mirror

A: REMOVAL AND INSTALLATION

- 1) Remove the gusset cover.

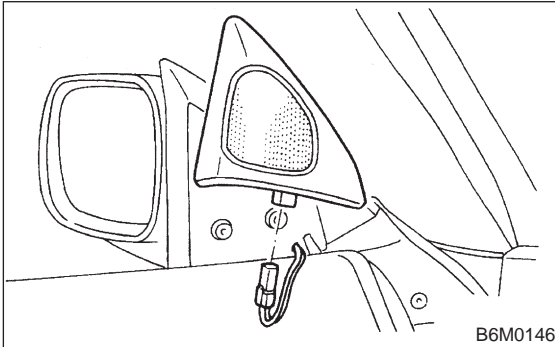

- 2) Remove inner remote control switch cover.

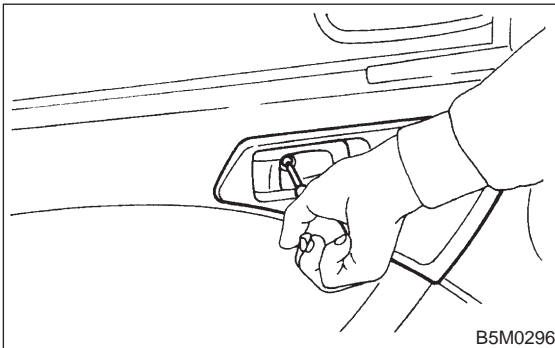

- 3) Remove front door trim.

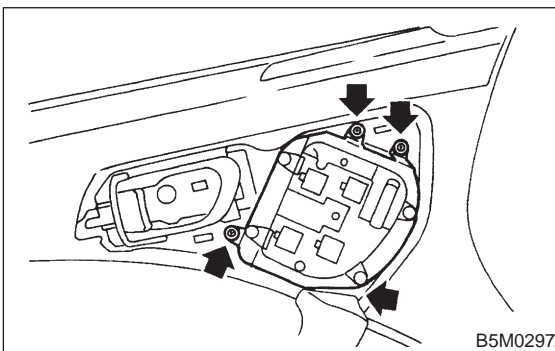

- 4) Remove front door trim.

- 5) Disconnect the door mirror connector.
6) Remove the door mirror installation screws.

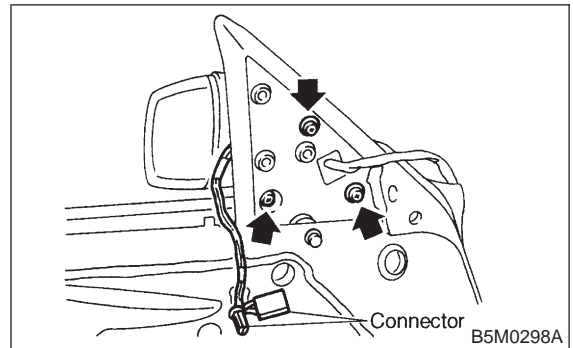

- 7) Installation is in the reverse order of removal.

14. Side Protector

A: REMOVAL AND INSTALLATION

Side protector consists of three parts; front fender, front door and rear door.

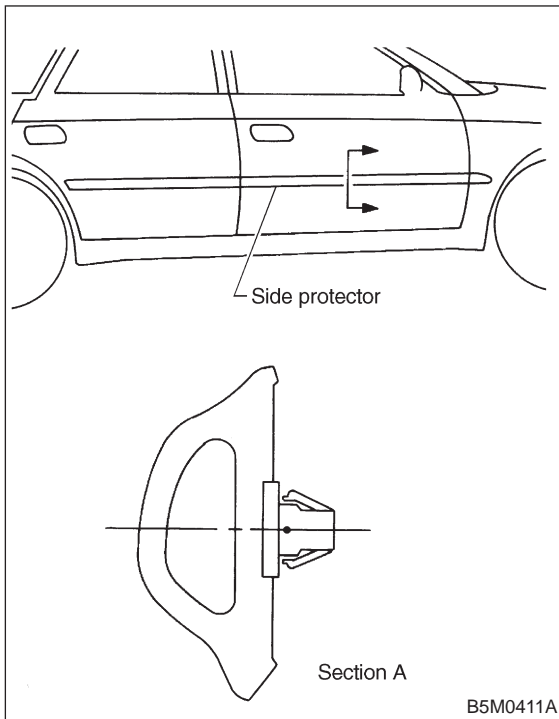

1. SIDE PROTECTOR FRONT FENDER PORTION

1) Remove bracket which secures mud guard to front fender.

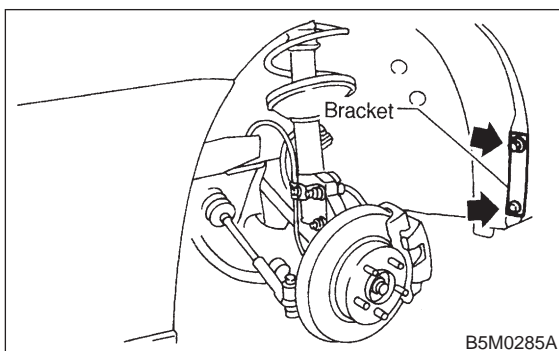

2) Remove mud guard. <Ref. to 5-1 [W9A1].> and <Ref. to 5-1 [W9A2].>

NOTE:

Detach the rear part of mud guard as required for the procedure. It is not necessary to remove the entire mud guard.

3) Use pliers to remove a clip from inside front fender. Remove it from vehicle body but keep it with side protector.

4) Installation is in the reverse order of removal.

CAUTION:

Insert clips firmly and carefully by hand. To avoid damaging clips, do not forcefully push or hit clips.

2. SIDE PROTECTOR FRONT DOOR AND REAR DOOR PORTIONS

1) Remove trim panel. <Ref. to 5-2 [W2A2].>

2) Use pliers to remove clips from inside of doors. Remove them from vehicle body but keep them with side protector.

NOTE:

Front door portion has five clips, rear door portion has four clips.

3) Installation is in the reverse order of removal.

CAUTION:

Insert clips firmly and carefully by hand. To avoid damaging clips, do not forcefully push or hit clips.

NOTE:

To install side protector front door and rear door portions, insert the first clip into the base hole [9 mm (0.35 in) dia.], and then insert other clips.

15. Roof Rail

A: REMOVAL AND INSTALLATION

- 1) Remove roof trim, rear quarter trim, pillar trim, etc. <Ref. to 5-3 [W5A0].>
- 2) Remove flange bolts.
- 3) Remove flange nuts.
- 4) Remove roof rail.

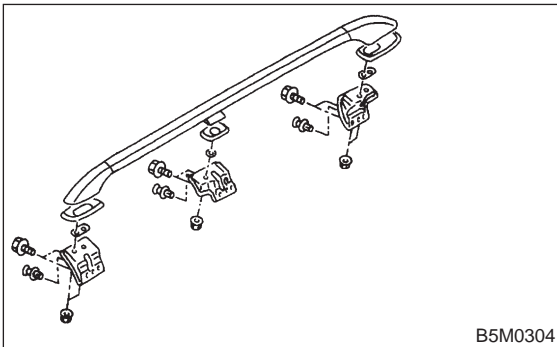

B5M0304

- 5) Installation is in the reverse order of removal.

CAUTION:

To prevent deformation, be sure to install roof rail in steps 4), 3), 2) and 1), in that order.

16. Sunroof

A: REMOVAL AND INSTALLATION

1. SEDAN AND WAGON REAR (EXCEPT OUTBACK)

- 1) Glass lid assembly:
 - (1) Completely open sun shade. (Push it back far.)
 - (2) Remove a clip and detach guide rail cover.
 - (3) Remove six nuts from the left and right lid bracket.
 - (4) Working inside, slightly raise glass lid assembly until it is disengaged from lid bracket.

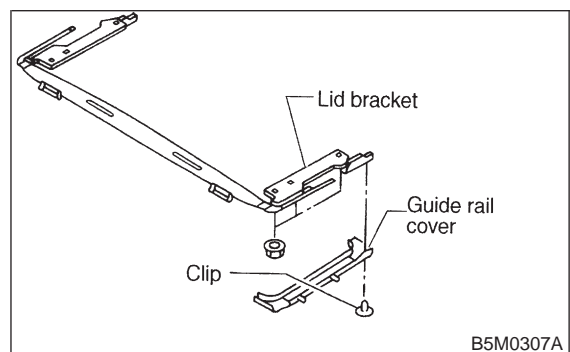

B5M0307A

- (5) Hold both ends of glass lid assembly and remove it at an angle.
- (6) Installation is in the reverse order of removal.

2) Sunroof motor and relay:

- (1) Remove center pillar trim upper. <Ref. to 5-3 [W5A3].>
- (2) Remove front pillar trim upper. <Ref. to 5-3 [W5A4].>
- (3) Remove assist grip on left side.
- (4) Remove sunvisor with hook.
- (5) Remove sunroof switch.
- (6) Remove rearview mirror.
- (7) While rolling up roof trim, disconnect harness clips and connector.
- (8) While rolling up roof trim, remove spot lamp bracket and sunroof motor.
- (9) Installation is in the reverse order of removal.

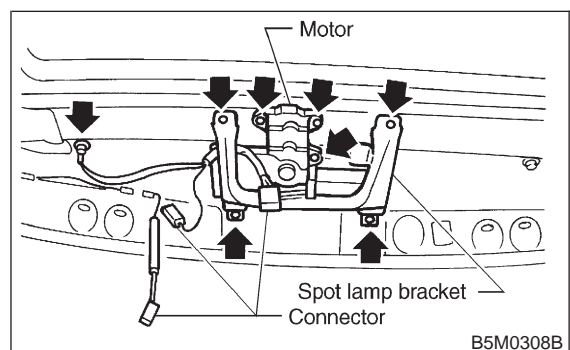

B5M0308B

15. Roof Rail

A: REMOVAL AND INSTALLATION

- 1) Remove roof trim, rear quarter trim, pillar trim, etc. <Ref. to 5-3 [W5A0].>
- 2) Remove flange bolts.
- 3) Remove flange nuts.
- 4) Remove roof rail.

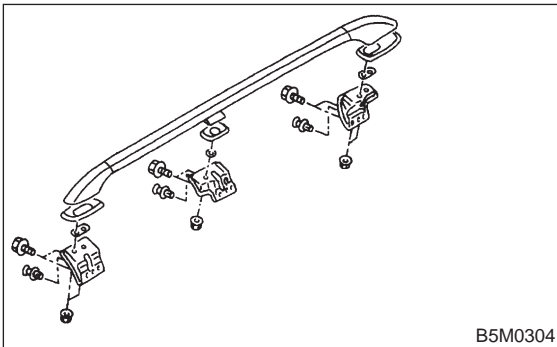

B5M0304

- 5) Installation is in the reverse order of removal.

CAUTION:

To prevent deformation, be sure to install roof rail in steps 4), 3), 2) and 1), in that order.

16. Sunroof

A: REMOVAL AND INSTALLATION

1. SEDAN AND WAGON REAR (EXCEPT OUTBACK)

- 1) Glass lid assembly:
 - (1) Completely open sun shade. (Push it back far.)
 - (2) Remove a clip and detach guide rail cover.
 - (3) Remove six nuts from the left and right lid bracket.
 - (4) Working inside, slightly raise glass lid assembly until it is disengaged from lid bracket.

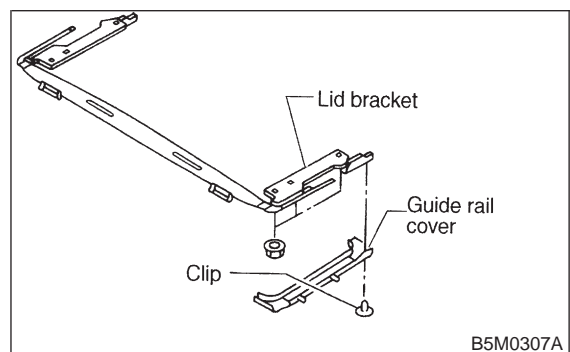

B5M0307A

- (5) Hold both ends of glass lid assembly and remove it at an angle.
- (6) Installation is in the reverse order of removal.

2) Sunroof motor and relay:

- (1) Remove center pillar trim upper. <Ref. to 5-3 [W5A3].>
- (2) Remove front pillar trim upper. <Ref. to 5-3 [W5A4].>
- (3) Remove assist grip on left side.
- (4) Remove sunvisor with hook.
- (5) Remove sunroof switch.
- (6) Remove rearview mirror.
- (7) While rolling up roof trim, disconnect harness clips and connector.
- (8) While rolling up roof trim, remove spot lamp bracket and sunroof motor.
- (9) Installation is in the reverse order of removal.

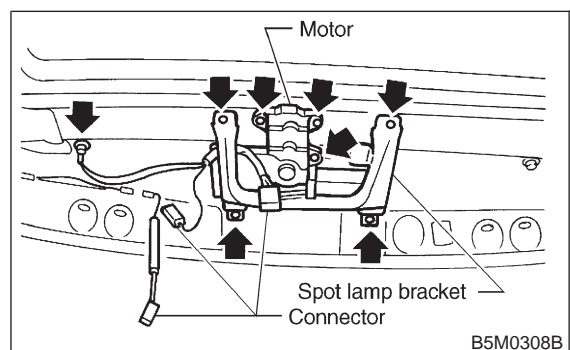

B5M0308B

3) Sunroof frame:

- (1) Remove sunroof switch, center and rear room lamps.
- (2) Remove roof trim, rear quarter trim, pillar trim, etc. <Ref. to 5-3 [W5A0].>
- (3) Remove glass lid assembly.
- (4) Remove two harness support clips.

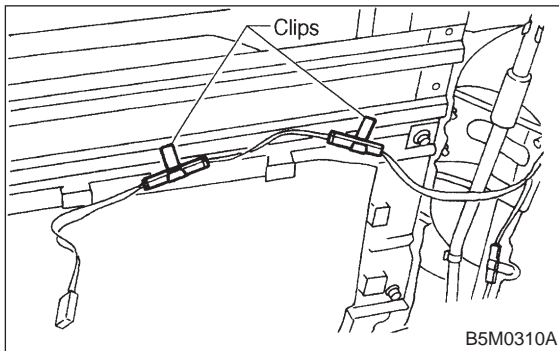

- (5) Disconnect harness clips and connector of sunroof motor.
- (6) Disconnect front and rear drain tubes.

CAUTION:

When installing drain tube, insert it securely into drain pipe.

Length A:

15 mm (0.59 in) or more

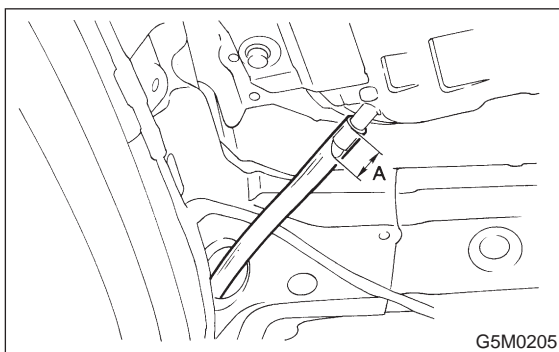

- (7) Remove eight nuts.

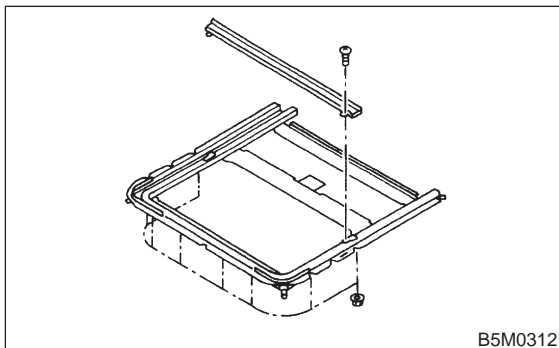

- (8) Remove set bracket mounting bolts.
- (9) Remove sunroof frame.

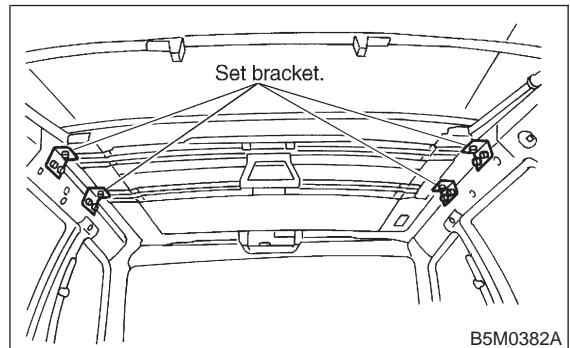

- (10) Installation is in the reverse order of removal.

2. WAGON FRONT (OUTBACK)

1) Sunroof panel:

- (1) Tilt up the front sunroof (Most upper position).
- (2) Disconnect ground cable from battery.
- (3) Remove sunroof switch then remove two bolts.
- (4) Remove cover then remove two nuts from tilt up assembly.
- (5) Take off the sunroof panel from body.

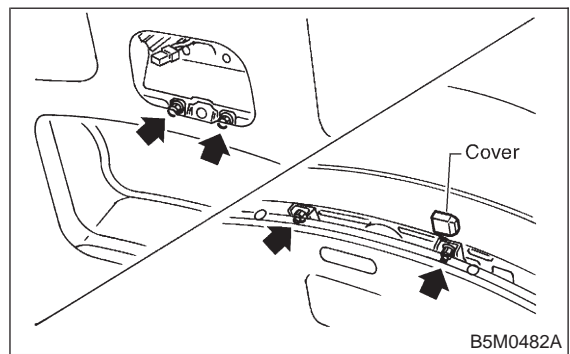

- (6) Installation is in the reverse order of removal.

CAUTION:

When installing sunroof panel, ensure not to pinch its panel end lip.

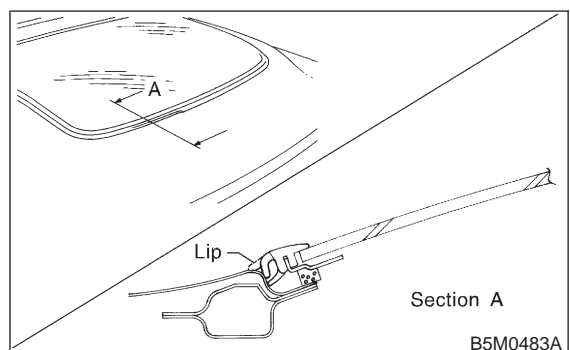

- 2) Sunroof motor assembly:
 (1) Remove sunroof panel. <Ref. to 5-1 [W16A2].>
 (2) Remove motor cover.
 (3) Disconnect connector then remove sunroof motor assembly.

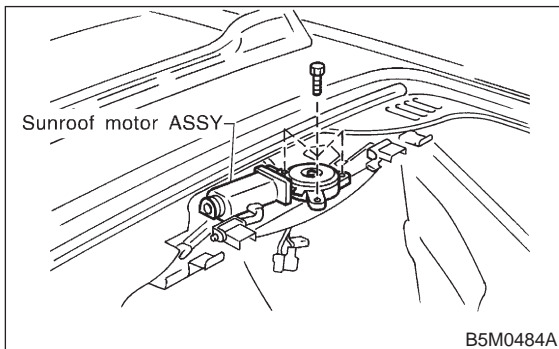

(4) Installation is in the reverse order of removal.

- 3) Sunroof flame:
 (1) Remove sunroof panel. <Ref. to 5-1 [W16A2].>
 (2) Remove roof trim panel. <Ref. to 5-3 [W5A9].>
 (3) Remove sunroof flame.

NOTE:

To facilitate installation, leave the two front mounting bolts on the body.

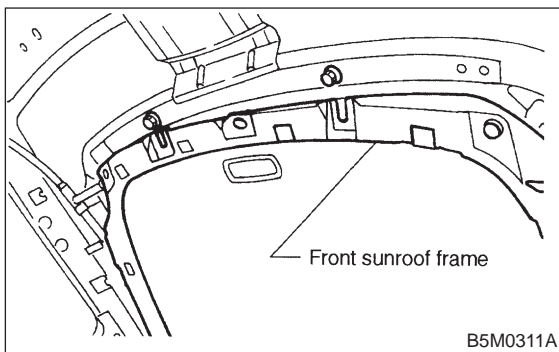

(4) Installation is in the reverse order of removal.

- 4) Tilt up assembly:
 (1) Remove sunroof flame. <Ref. to 5-1 [W16A2].>
 (2) Remove tilt up assembly.

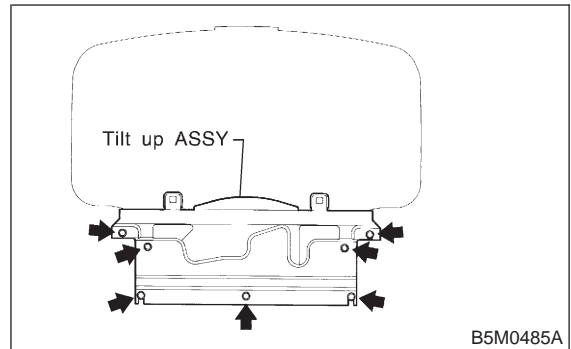

(3) Installation is in the reverse order of removal.

B: ADJUSTMENT

1. SEDAN AND WAGON REAR (EXCEPT OUTBACK)

- 1) Alignment of height between glass lid assembly and roof panel:

- (1) Remove guide rail cover.
 (2) Loosen nuts and adjust height by adding (Max: two pieces) and extracting (Max: one piece) shim(s) (Standard: one piece) between glass lid assembly and lid bracket.

Difference in height between glass lid assembly and roof panel:

0±0.5 mm (0±0.020 in)

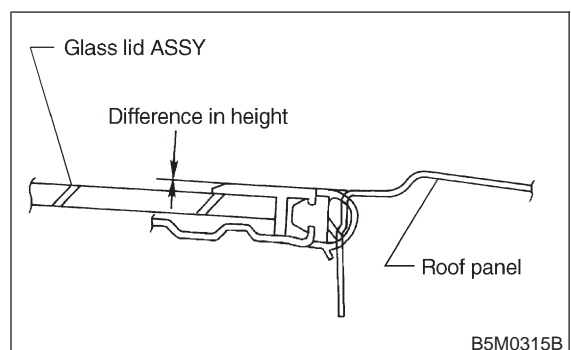
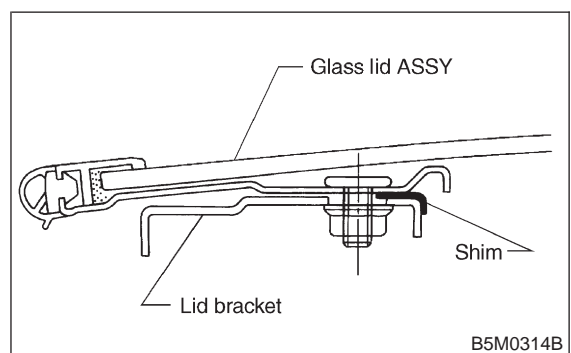

- 2) Alignment of glass lid assembly with roof panel:
 (1) Remove guide rail cover.
 (2) Loosen nuts and move glass lid assembly to either side to adjust front, rear, right, and left side partitions.

Partition clearance:
 $7.0 \pm 0.5 \text{ mm } (0.276 \pm 0.020 \text{ in})$

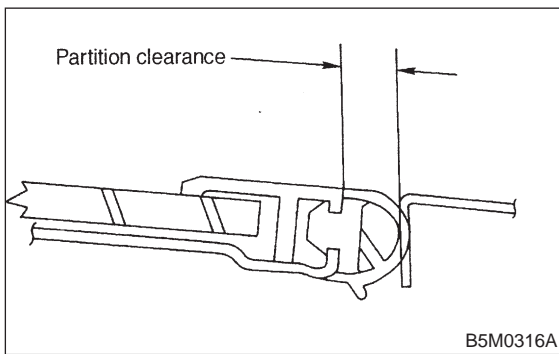

- 3) Checking for movement of glass lid assembly itself:

- (1) Before installing sunroof motor, check glass lid assembly for movement.
 (2) Place a cloth on glass lid assembly and sun shade, and attach a spring scale to glass lid assembly edge using the cloth.

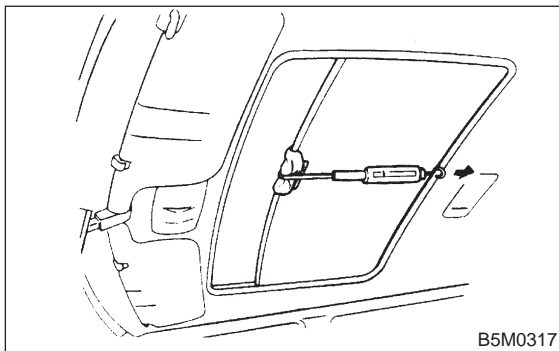

- (3) Pull spring scale to measure force required to move glass lid assembly.

Force required to move glass lid assembly and sun shade trim:

Less than 196 N (20 kg, 44 lb)

Considerable effort is required to start glass lid assembly moving, so take scale reading while glass lid assembly is moving smoothly.

- (4) If force required exceeds specifications, check the following points:

- Glass lid assembly, sun shade and deflector and guide rail assembly for improper installation
- Cable for seizure

2. WAGON FRONT (OUTBACK)

- 1) Alignment of height between sunroof panel and roof panel

Loosen sunroof panel installation bolts and nuts then adjust height by adding (Max: two pieces) and extracting (Max: one piece) shim(s) (Standard: one piece) between sunroof panel hinge and body.

Difference in height between sunroof panel and roof panel:
 $0 \pm 1.0 \text{ mm } (0 \pm 0.039 \text{ in})$

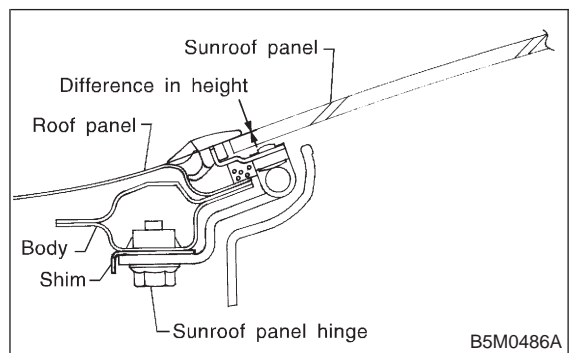

- 2) Alignment of partition clearance
 Loosen sunroof panel installation bolts and nuts then move glass to either side to adjust front, rear, right, and left side partitions.

Partition clearance:
 $1 \pm 1.0 \text{ mm } (0.04 \pm 0.039 \text{ in})$

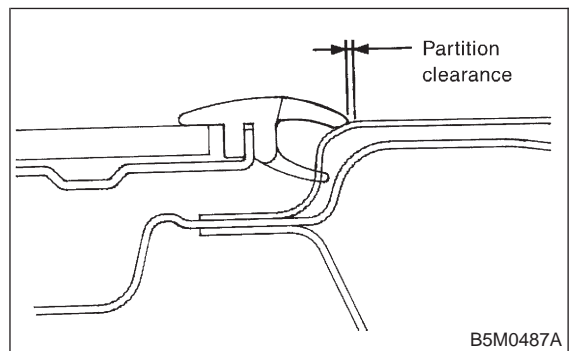

17. Undercover

A: REMOVAL AND INSTALLATION

- 1) Remove undercover mounting bolts.

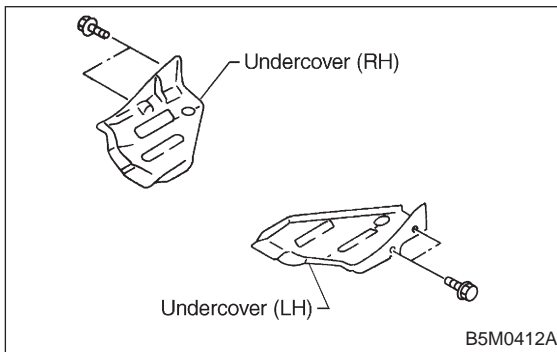

- 2) Installation is in the reverse order of removal.

NOTE:

Undercover is bolted along with mud guard.

18. Rear Spoiler

A: REMOVAL AND INSTALLATION

- 1) Open trunk lid.
- 2) Disconnect high-mount stop light connector located inside the trunk lid.
- 3) Remove rubber caps.

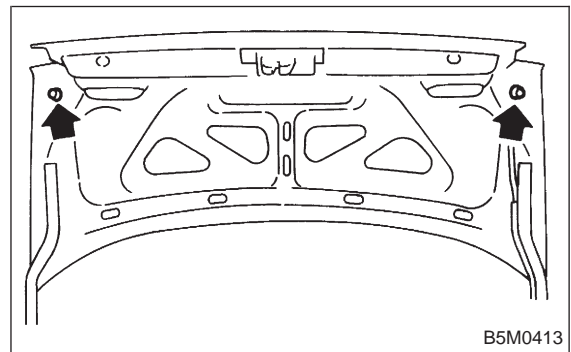

- 4) Remove rear spoiler mounting nuts.

CAUTION:

When removing nuts, be careful not to drop them inside rear gate.

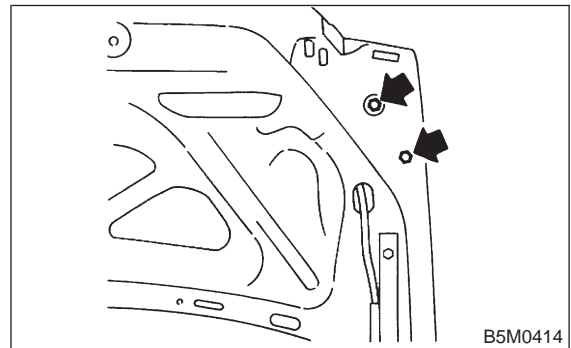

- 5) Installation is in the reverse order of removal.

Tightening torque:

7.4 ± 2.0 N·m (0.75 ± 0.2 kg·m, 5.4 ± 1.4 ft·lb)

17. Undercover

A: REMOVAL AND INSTALLATION

- 1) Remove undercover mounting bolts.

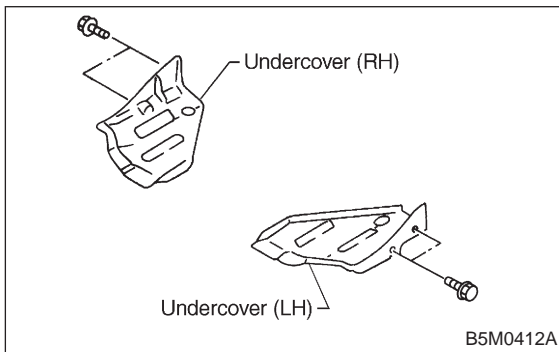

- 2) Installation is in the reverse order of removal.

NOTE:

Undercover is bolted along with mud guard.

18. Rear Spoiler

A: REMOVAL AND INSTALLATION

- 1) Open trunk lid.
- 2) Disconnect high-mount stop light connector located inside the trunk lid.
- 3) Remove rubber caps.

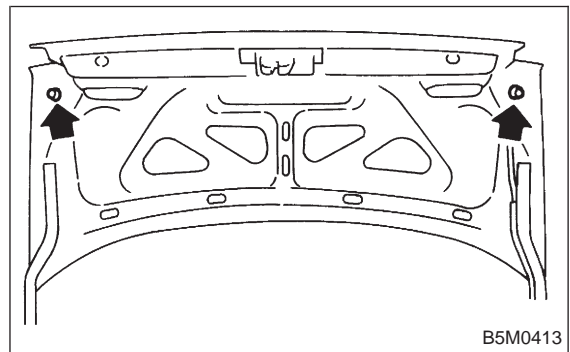

- 4) Remove rear spoiler mounting nuts.

CAUTION:

When removing nuts, be careful not to drop them inside rear gate.

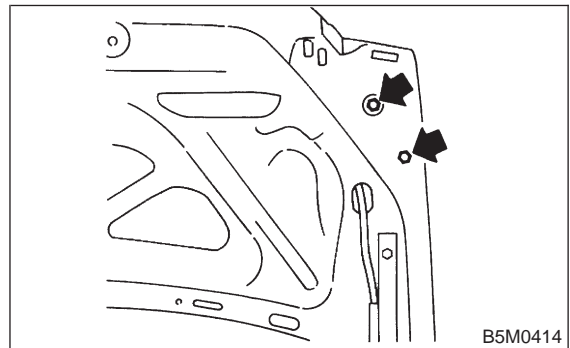

- 5) Installation is in the reverse order of removal.

Tightening torque:

7.4 ± 2.0 N·m (0.75 ± 0.2 kg·m, 5.4 ± 1.4 ft·lb)

19. Roof Spoiler

A: REMOVAL AND INSTALLATION

1) Open rear gate and remove rear gate trim upper and side.

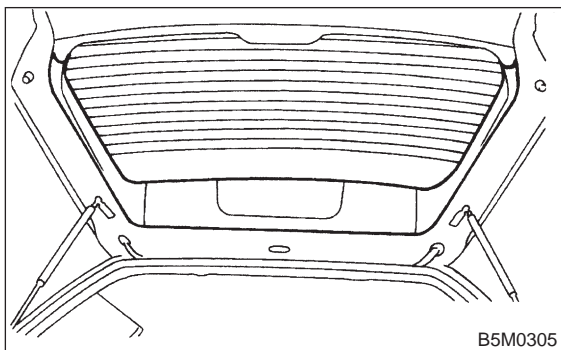

2) Remove high-mount stop light. <Ref. to 6-2 [W6A4].>

3) Remove plastic caps and harness covers.

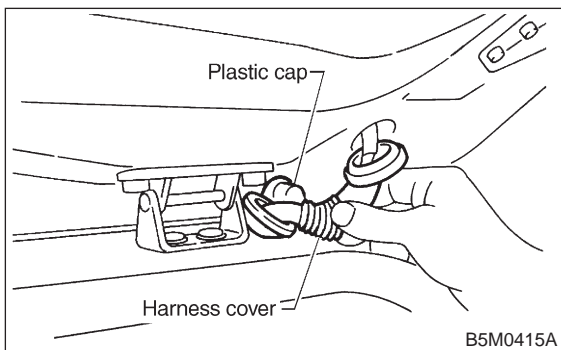

4) Remove roof spoiler mounting nuts.

CAUTION:

- When removing nuts, be careful not to drop them inside rear gate.
- Be careful since two-sided tape is placed between roof spoiler and body panel.

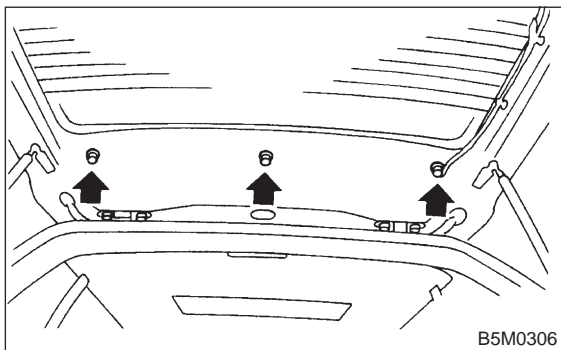

5) Installation is in the reverse order of removal.

Tightening torque:

7.4±2.0 N-m (0.75±0.2 kg-m, 5.4±1.4 ft-lb)

20. Side Spoiler

A: REMOVAL AND INSTALLATION

1) Remove tapping screws, clip and end cover.

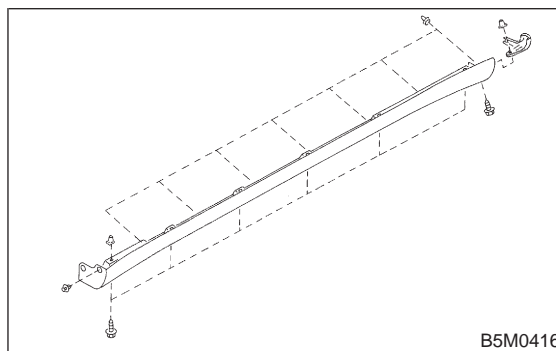

2) Installation is in the reverse order of removal.

19. Roof Spoiler

A: REMOVAL AND INSTALLATION

1) Open rear gate and remove rear gate trim upper and side.

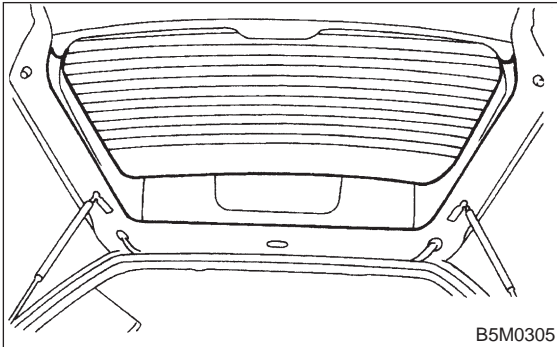

2) Remove high-mount stop light. <Ref. to 6-2 [W6A4].>
3) Remove plastic caps and harness covers.

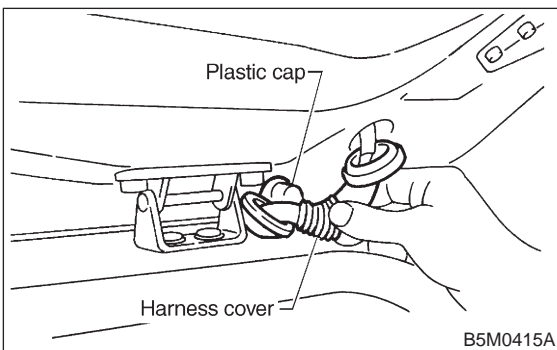

4) Remove roof spoiler mounting nuts.

CAUTION:

- When removing nuts, be careful not to drop them inside rear gate.
- Be careful since two-sided tape is placed between roof spoiler and body panel.

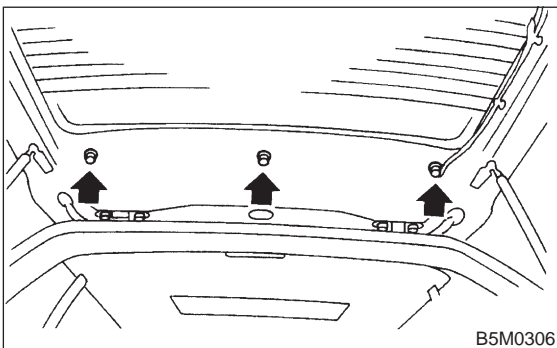

5) Installation is in the reverse order of removal.

Tightening torque:

7.4±2.0 N·m (0.75±0.2 kg·m, 5.4±1.4 ft·lb)

20. Side Spoiler

A: REMOVAL AND INSTALLATION

1) Remove tapping screws, clip and end cover.

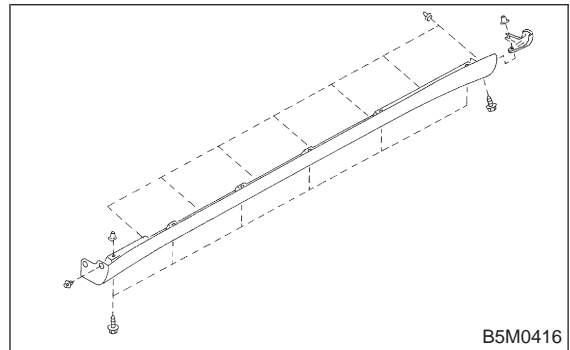

2) Installation is in the reverse order of removal.

21. Front Under Spoiler

A: REMOVAL AND INSTALLATION

- 1) Remove clips.

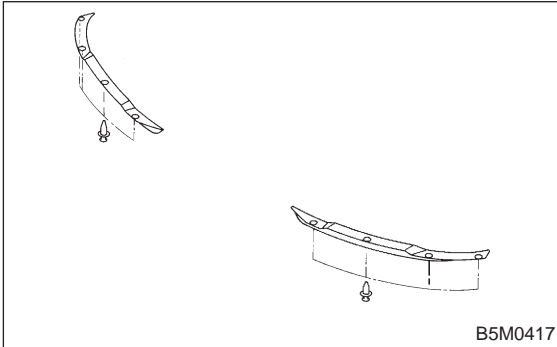

- 2) Installation is in the reverse order of removal.

22. Airdam Skirt

A: REMOVAL AND INSTALLATION

- 1) Remove airdam skirt mounting bolts and clips.

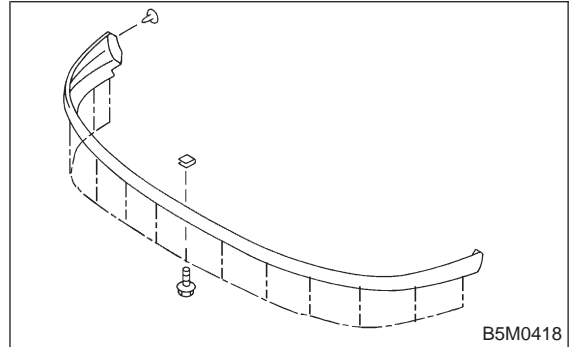

- 2) Installation is in the reverse order of removal.

21. Front Under Spoiler

A: REMOVAL AND INSTALLATION

- 1) Remove clips.

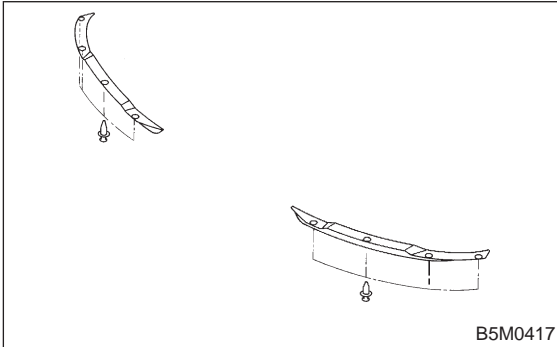

- 2) Installation is in the reverse order of removal.

22. Airdam Skirt

A: REMOVAL AND INSTALLATION

- 1) Remove airdam skirt mounting bolts and clips.

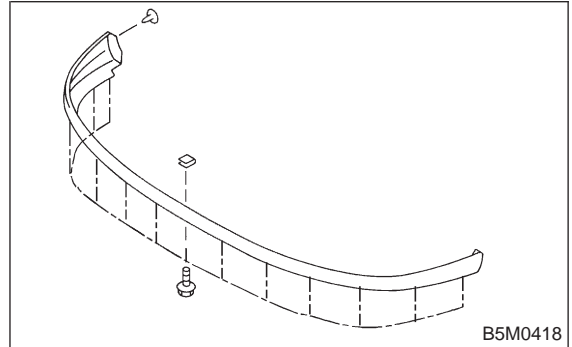

- 2) Installation is in the reverse order of removal.

23. Rear Under Spoiler

A: REMOVAL AND INSTALLATION

1) Remove tapping screws and clips.

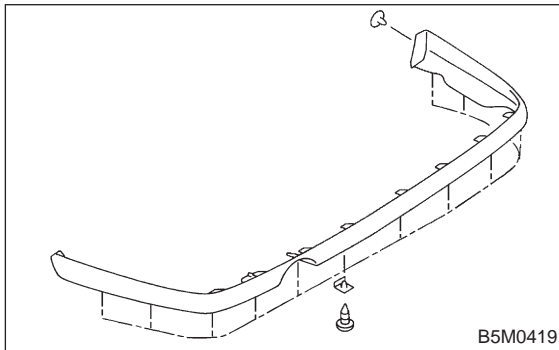

2) Installation is in the reverse order of removal.

NOTE:

- 12 tapping screws are used for Sedan.
- 14 tapping screws are used for Wagon.

1. Sunroof

Entry of water into compartment	<ol style="list-style-type: none"> (1) Check roof panel and glass lid assembly for improper or poor sealing. (2) Check drain tube for clogging. (3) Check sunroof frame seal and body for improper fit.
Booming noise	<ol style="list-style-type: none"> (1) Check glass lid assembly and roof panel for improper clearance. (2) Check sun shade and roof trim for improper clearance.
Abnormal motor noise	<ol style="list-style-type: none"> (1) Check motor for looseness. (2) Check gears and bearings for wear. (3) Check cable for wear. (4) Check cable pipe for deformities.
Failure of sunroof to operate (Motor operates properly.)	<ol style="list-style-type: none"> (1) Check guide rail for foreign particles. (2) Check guide rail for improper installation. (3) Check parts for mutual interference. (4) Check cable slider for improper clinching. (5) Check cable for improper installation. (6) Check clutch adjustment nut for improper tightness.
Motor does not rotate or rotates improperly. (Use sunroof wrench to check operation.)	<ol style="list-style-type: none"> (1) Check fuse for blowout. (2) Check switch for improper function. (3) Check motor for incorrect terminal voltage. (4) Check relay for improper operation. (5) Check poor grounding system. (6) Check cords for discontinuity and terminals for poor connections. (7) Check limit switch for improper operation.

1. Door Alignment

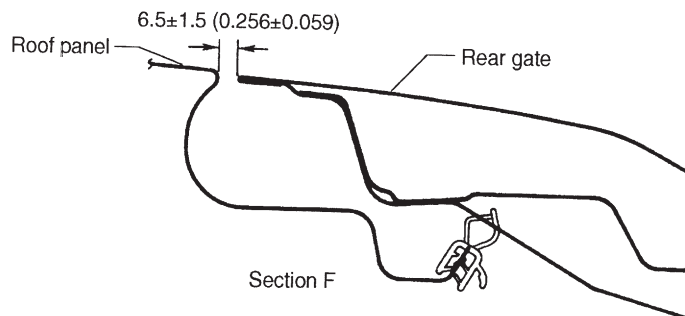
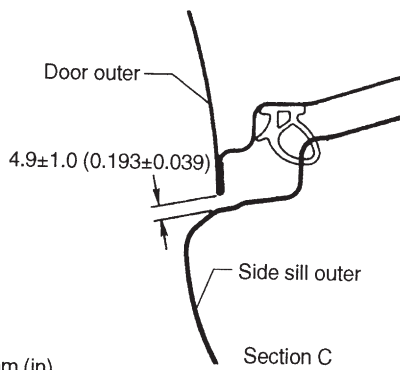
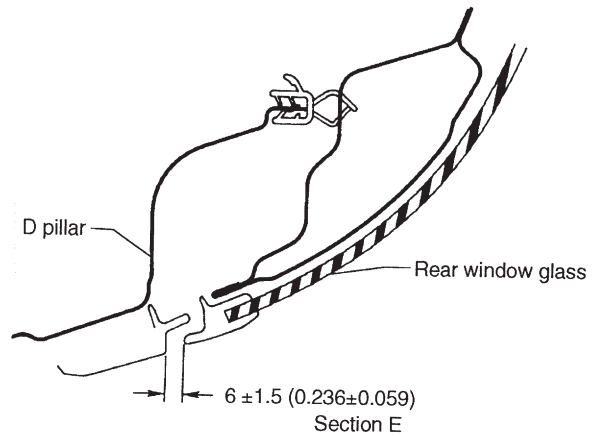
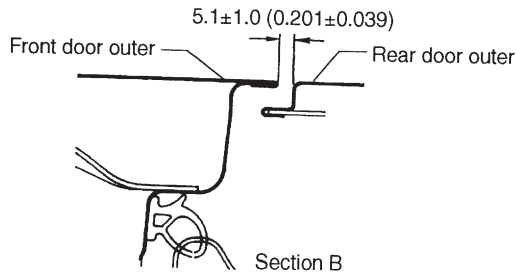
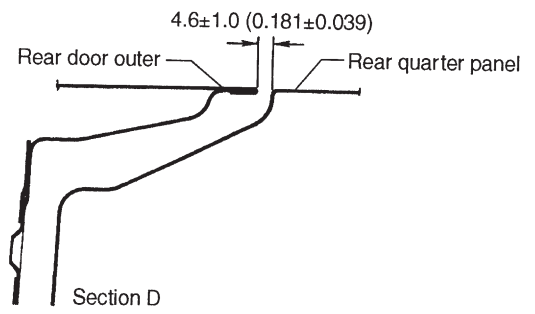
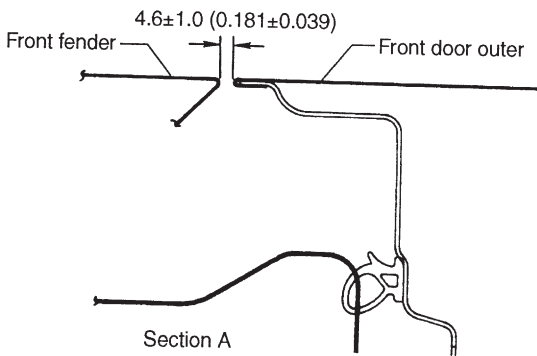
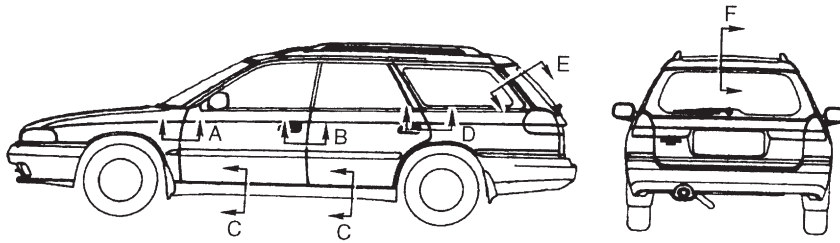

Unit: mm (in)

1. Front Door

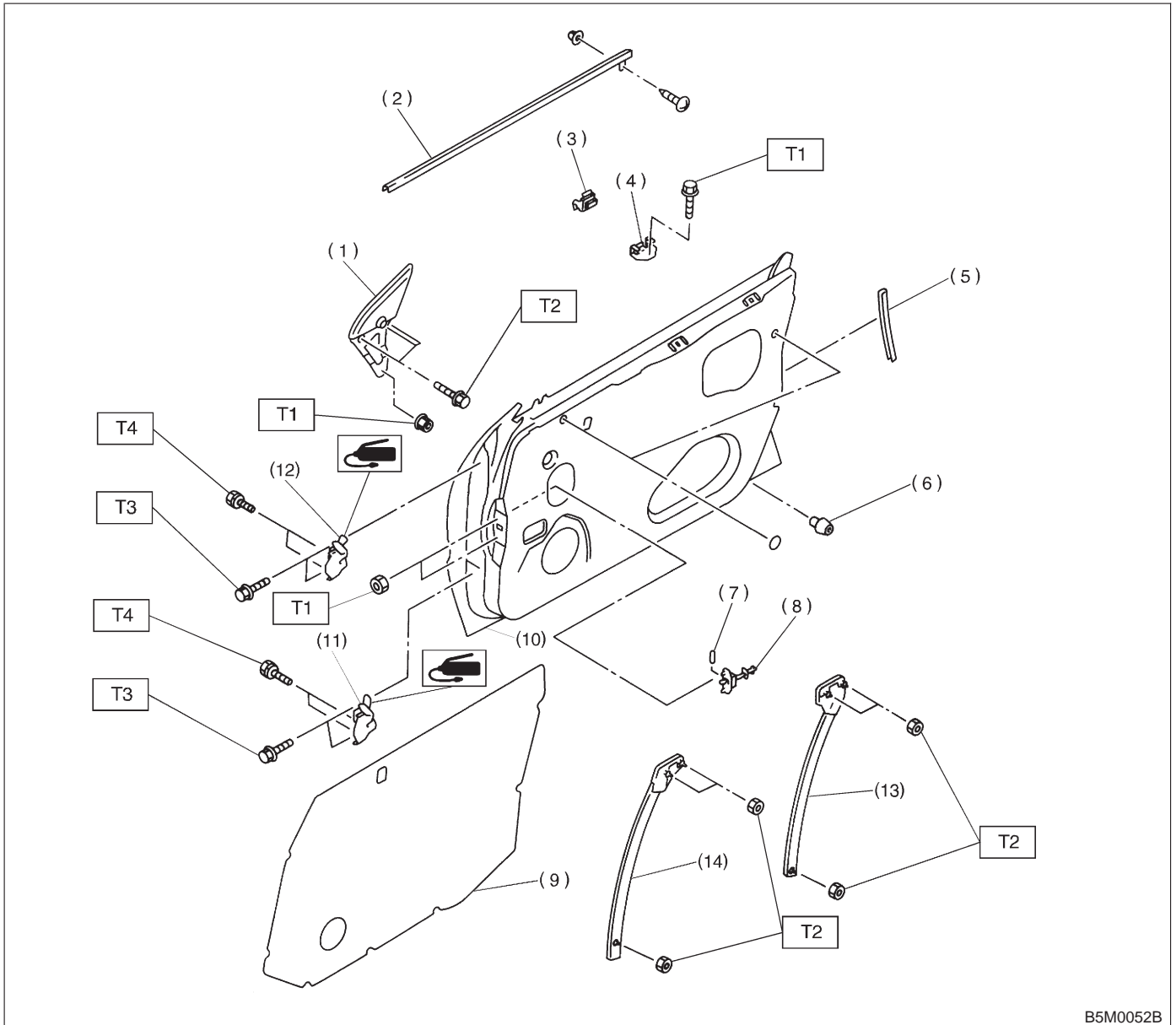

- | | |
|--------------------------|------------------------|
| (1) Gusset | (8) Checker |
| (2) Weatherstrip (Outer) | (9) Sealing cover |
| (3) Stabilizer (Outer) | (10) Door panel |
| (4) Stabilizer (Inner) | (11) Lower hinge |
| (5) Protector | (12) Upper hinge |
| (6) Stopper | (13) Door sash (Rear) |
| (7) Knock pin | (14) Door sash (Front) |

Tightening torque: N-m (kg-m, ft-lb)

T1: 7.4±2.0 (0.75±0.2, 5.4±1.4)

T2: 13±3 (1.3±0.3, 9.4±2.2)

T3: 25±3 (2.5±0.3, 18.1±2.2)

T4: 29±5 (3.0±0.5, 21.7±3.6)

2. Rear Door

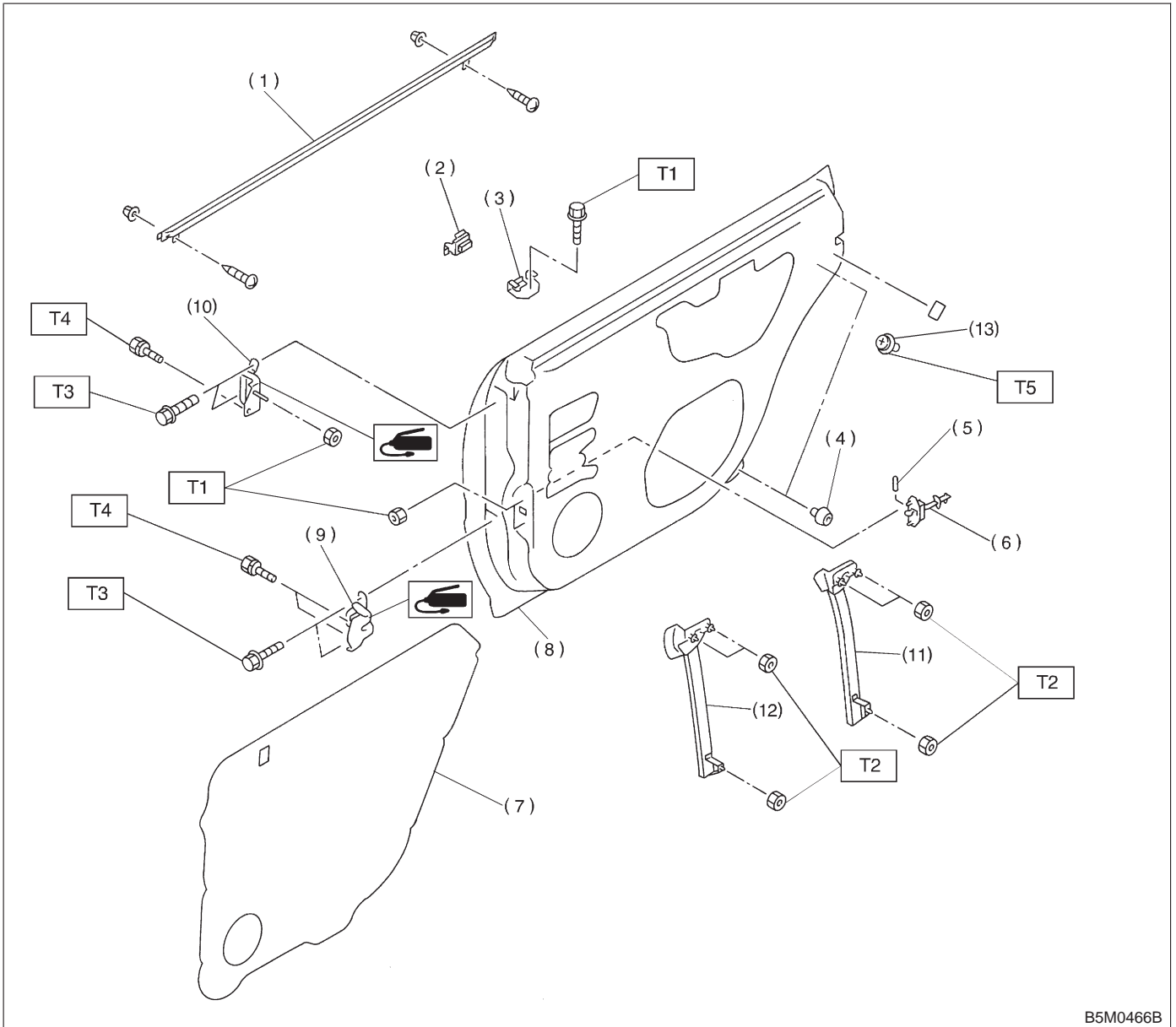

B5M0466B

- | | |
|--------------------------|------------------------|
| (1) Weatherstrip (Outer) | (8) Door panel |
| (2) Stabilizer (Outer) | (9) Lower hinge |
| (3) Stabilizer (Inner) | (10) Upper hinge |
| (4) Stopper | (11) Door sash (Rear) |
| (5) Knock pin | (12) Door sash (Front) |
| (6) Checker | (13) Rear door catcher |
| (7) Seating cover | |

Tightening torque: N-m (kg-m, ft-lb)

T1: 7.4±2.0 (0.75±0.2, 5.4±1.4)

T2: 14±4 (1.4±0.4, 10.1±2.9)

T3: 25±3 (2.5±0.3, 18.1±2.2)

T4: 29±5 (3.0±0.5, 21.7±3.6)

T5: 37±10 (3.8±1.0, 27.5±7.2)

3. Fixed Glass

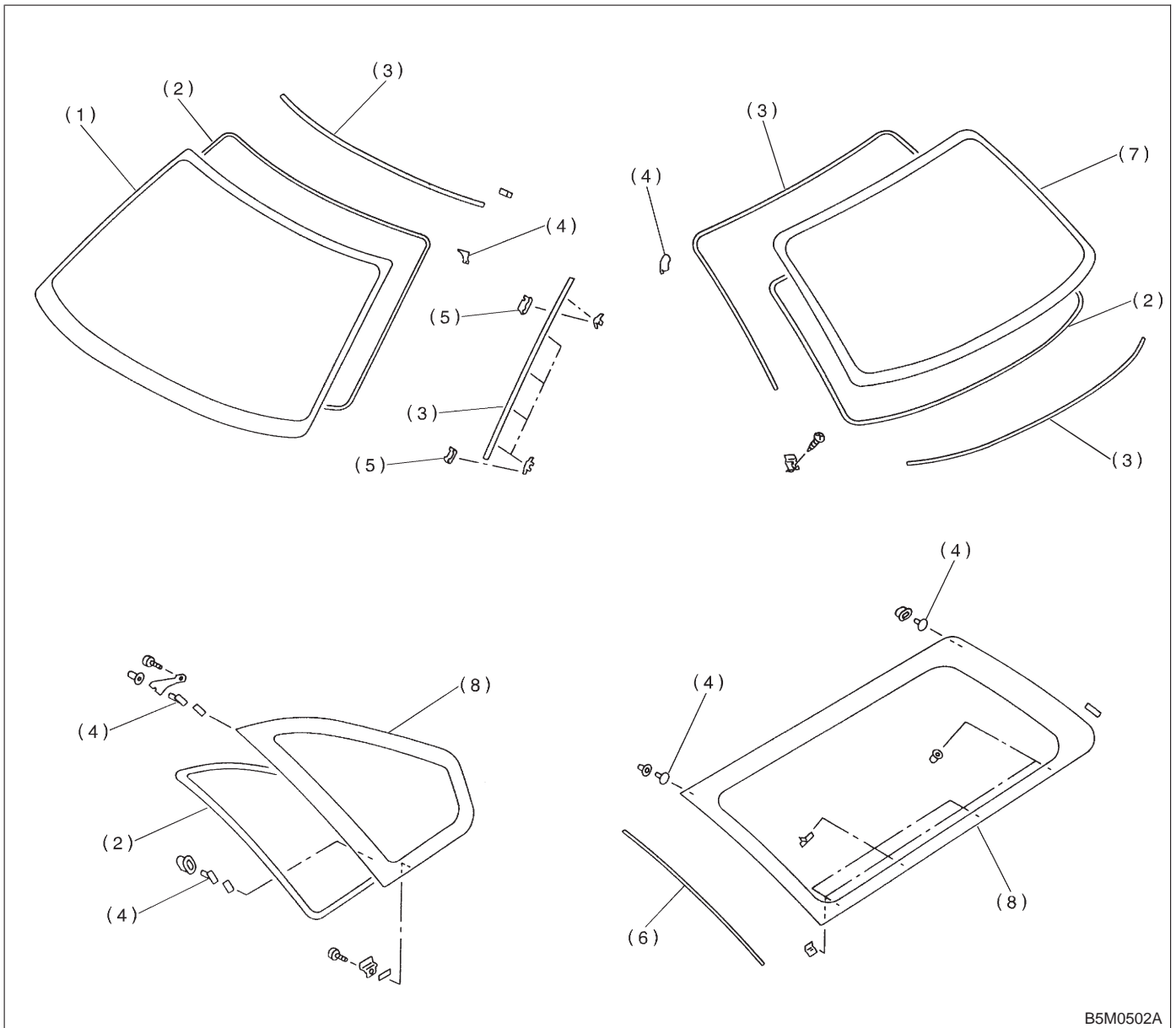

B5M0502A

- (1) Windshield glass
- (2) Dam rubber
- (3) Molding
- (4) Locate pin
- (5) Fastener
- (6) Garnish
- (7) Rear window glass
- (8) Rear quarter glass

4. Front Door Glass

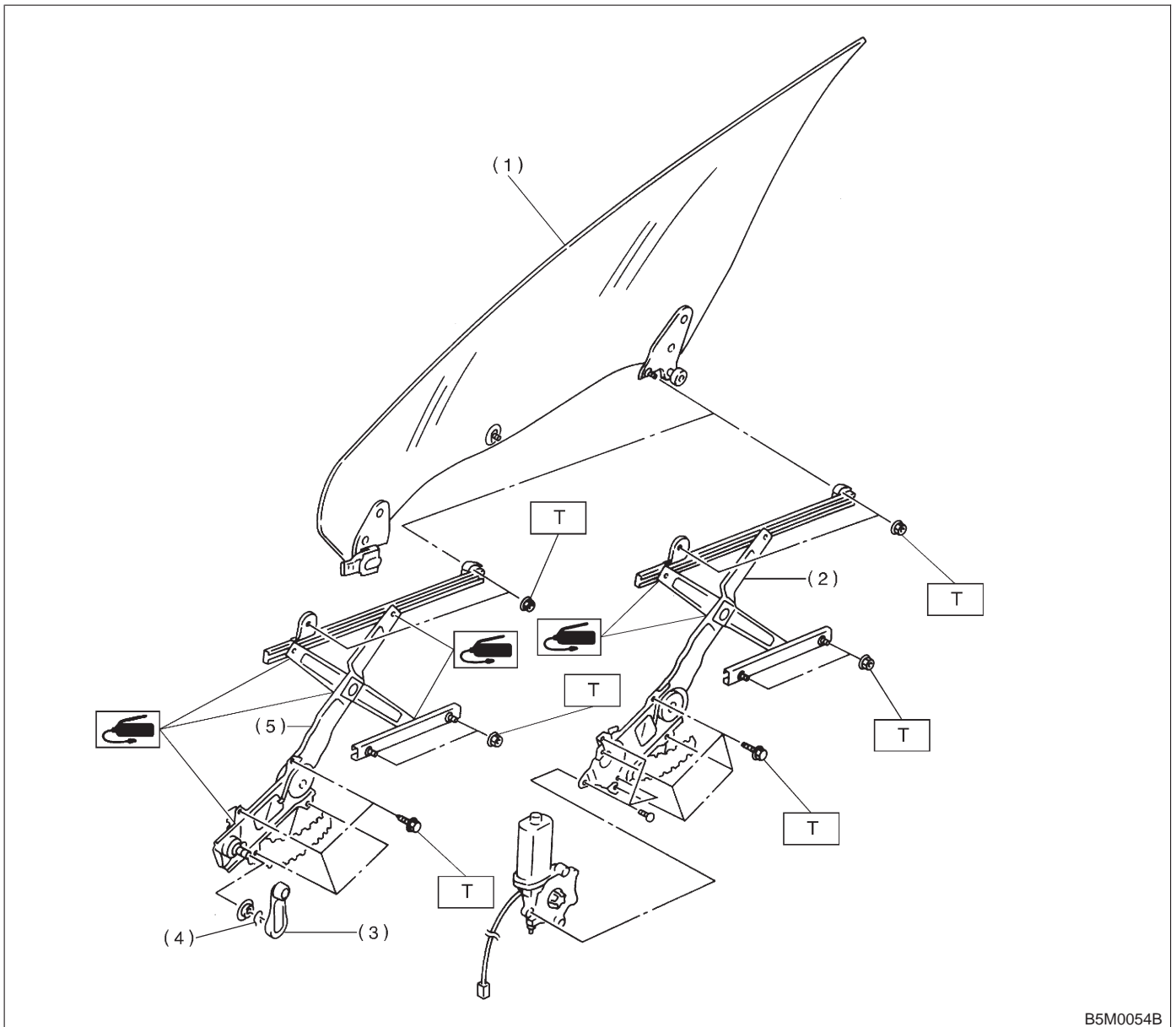

B5M0054B

- (1) Glass
- (2) Regulator and motor ASSY
- (3) Regulator handle (Except power window)
- (4) Retainer spring
- (5) Regulator ASSY

Tightening torque: N-m (kg-m, ft-lb)
T: 7.4±2.0 (0.75±0.2, 5.4±1.4)

5. Rear Door Glass

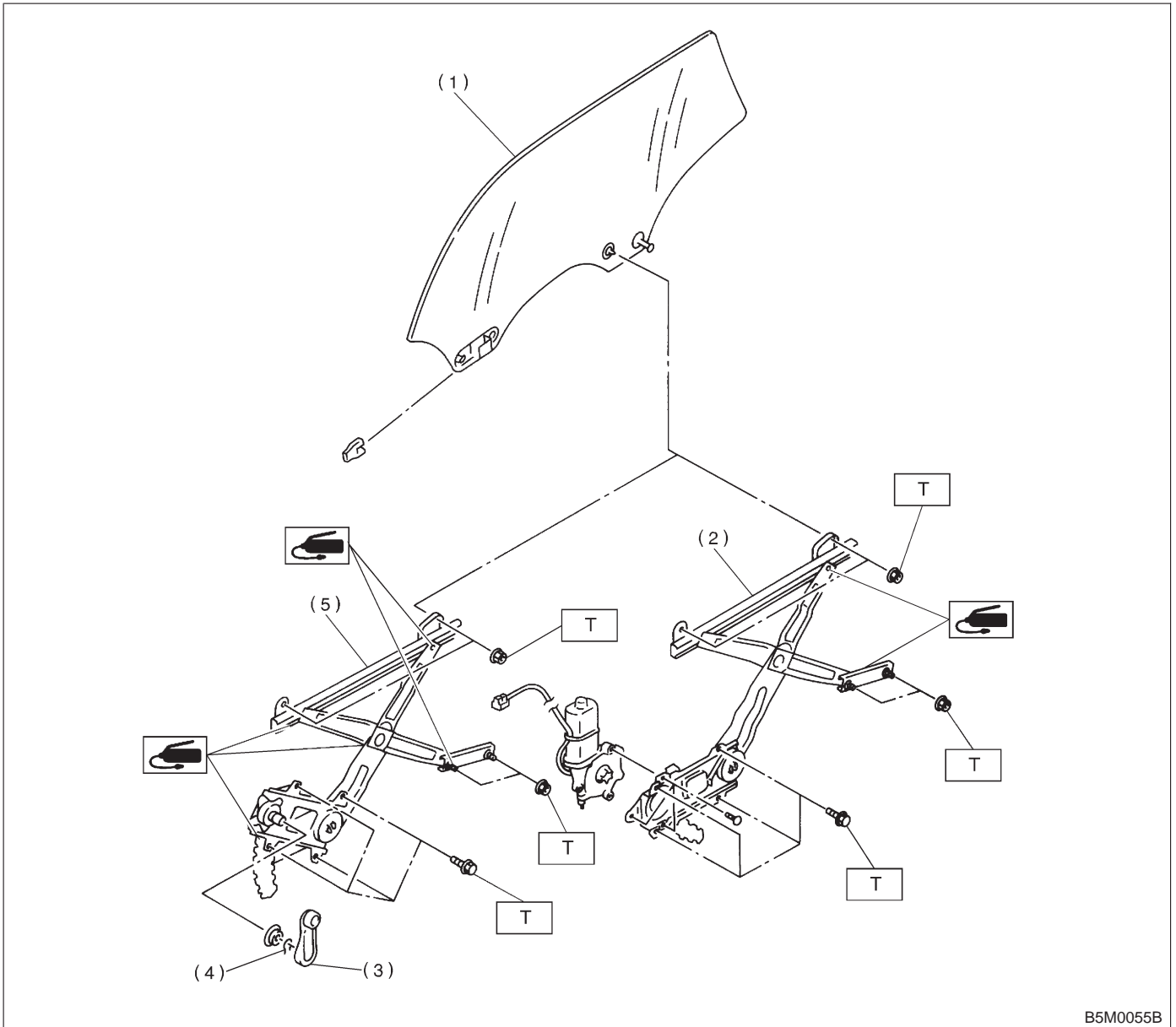

B5M0055B

- (1) Glass
- (2) Regulator and motor ASSY
- (3) Regulator handle (Except power window)
- (4) Retainer spring
- (5) Regulator ASSY

Tightening torque: N-m (kg-m, ft-lb)
T: 7.4±2.0 (0.75±0.2, 5.4±1.4)

6. Rear Gate and Glass

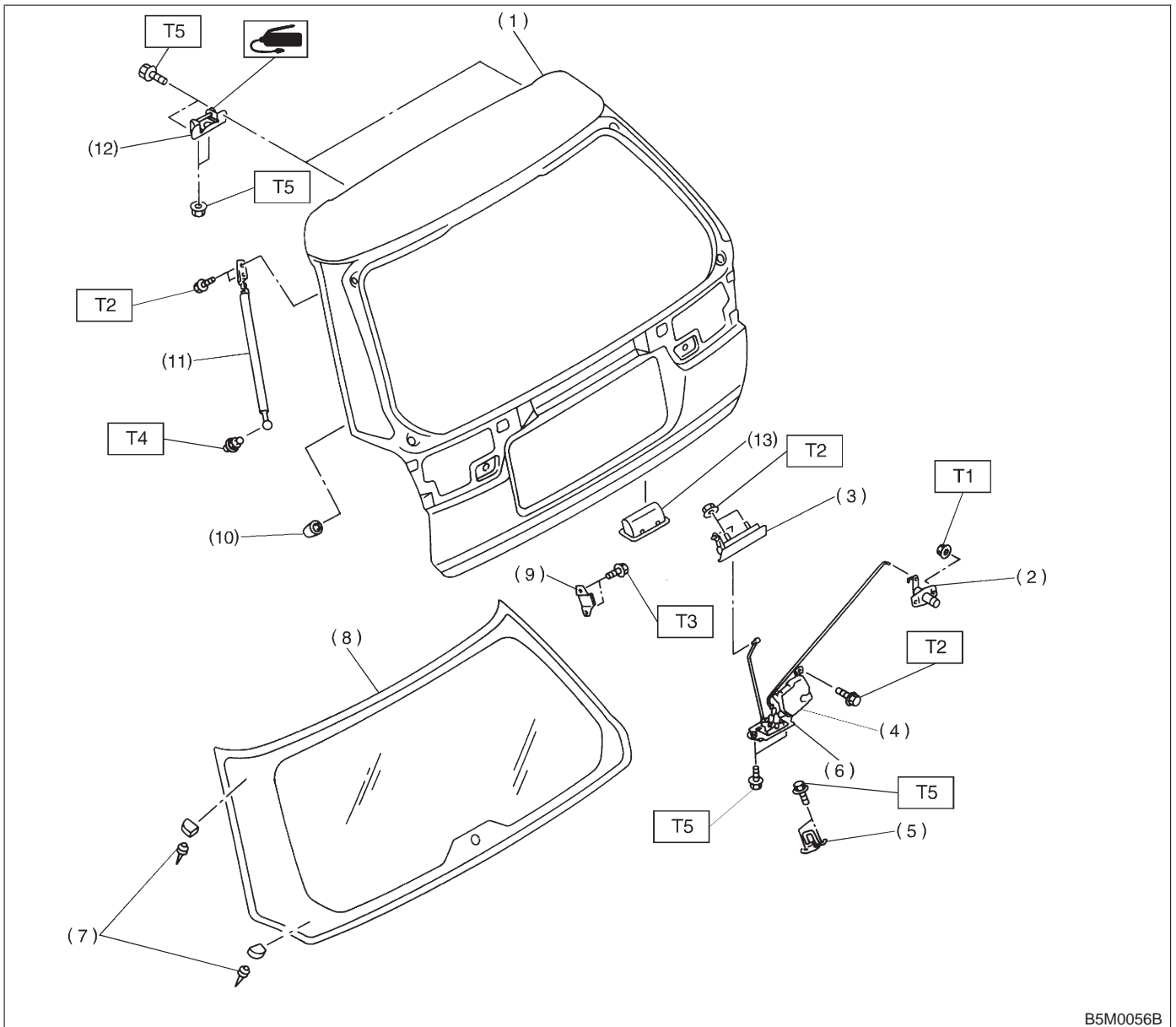

B5M0056B

- | | |
|------------------------|-----------------------|
| (1) Rear gate | (8) Glass |
| (2) Key cylinder | (9) Buffer |
| (3) Outer handle | (10) Stopper |
| (4) Door lock actuator | (11) Gas stay |
| (5) Striker | (12) Hinge |
| (6) Latch | (13) Rear gate handle |
| (7) Glass pin | |

Tightening torque: N-m (kg-m, ft-lb)

T1: 4.4±1.5 (0.45±0.15, 3.3±1.1)

T2: 7.4±2.0 (0.75±0.2, 5.4±1.4)

T3: 13±3 (1.3±0.3, 9.4±2.2)

T4: 14±4 (1.4±0.4, 10.1±2.9)

T5: 25±5 (2.5±0.5, 18.1±3.6)

7. Door Lock Assembly

A: FRONT DOOR

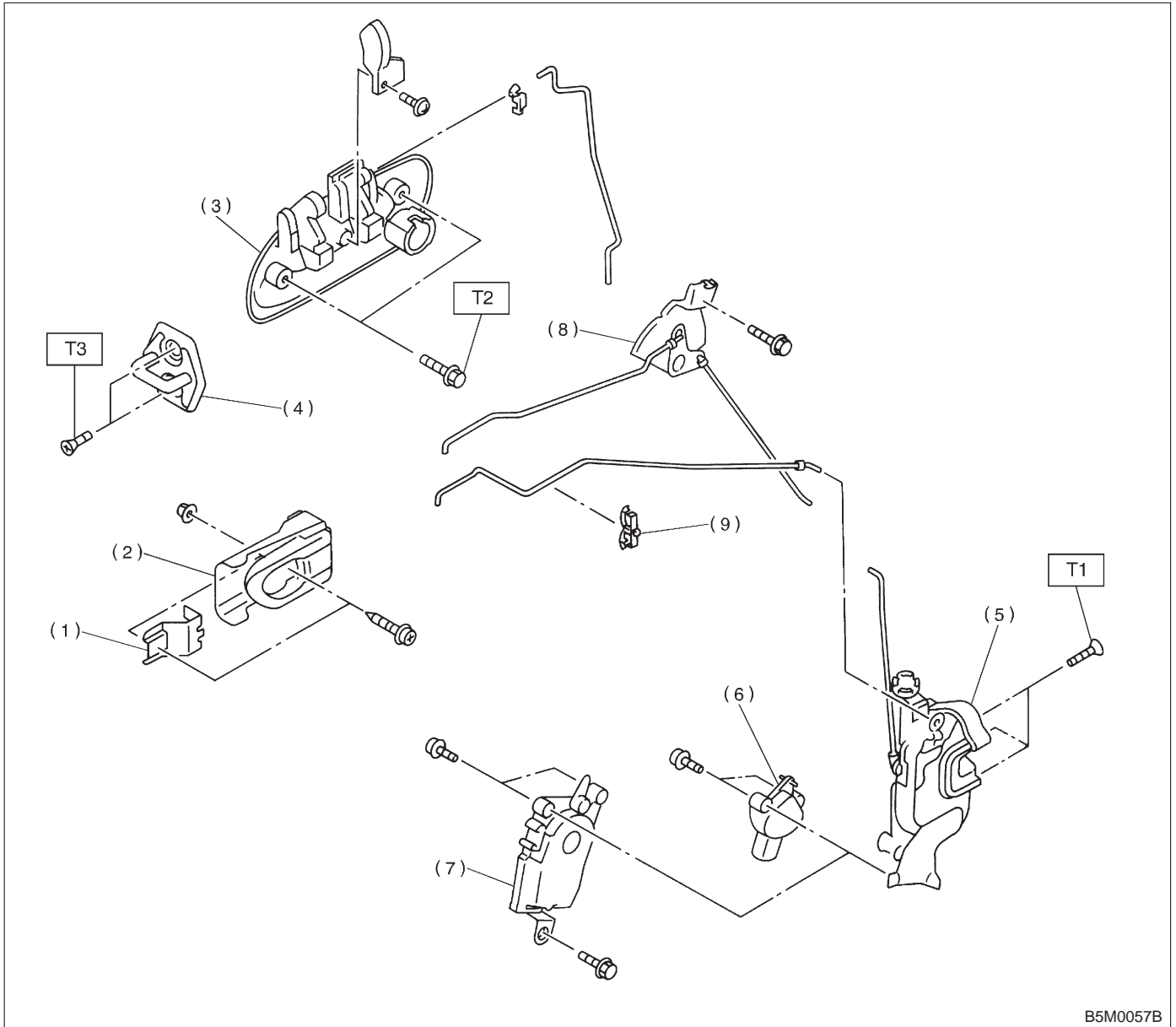

- | | |
|-----------------------|-----------------------------|
| (1) Holder remote | (6) Switch ASSY |
| (2) Inner remote ASSY | (7) Auto-door lock actuator |
| (3) Door outer handle | (8) Bell crank |
| (4) Striker | (9) Rod holder |
| (5) Door latch | |

Tightening torque: N·m (kg·m, ft·lb)
T1: 6.4±2.0 (0.65±0.2, 4.7±1.4)
T2: 7.4±2.0 (0.75±0.2, 5.4±1.4)
T3: 14±4 (1.4±0.4, 10.1±2.9)

8. Door Trim

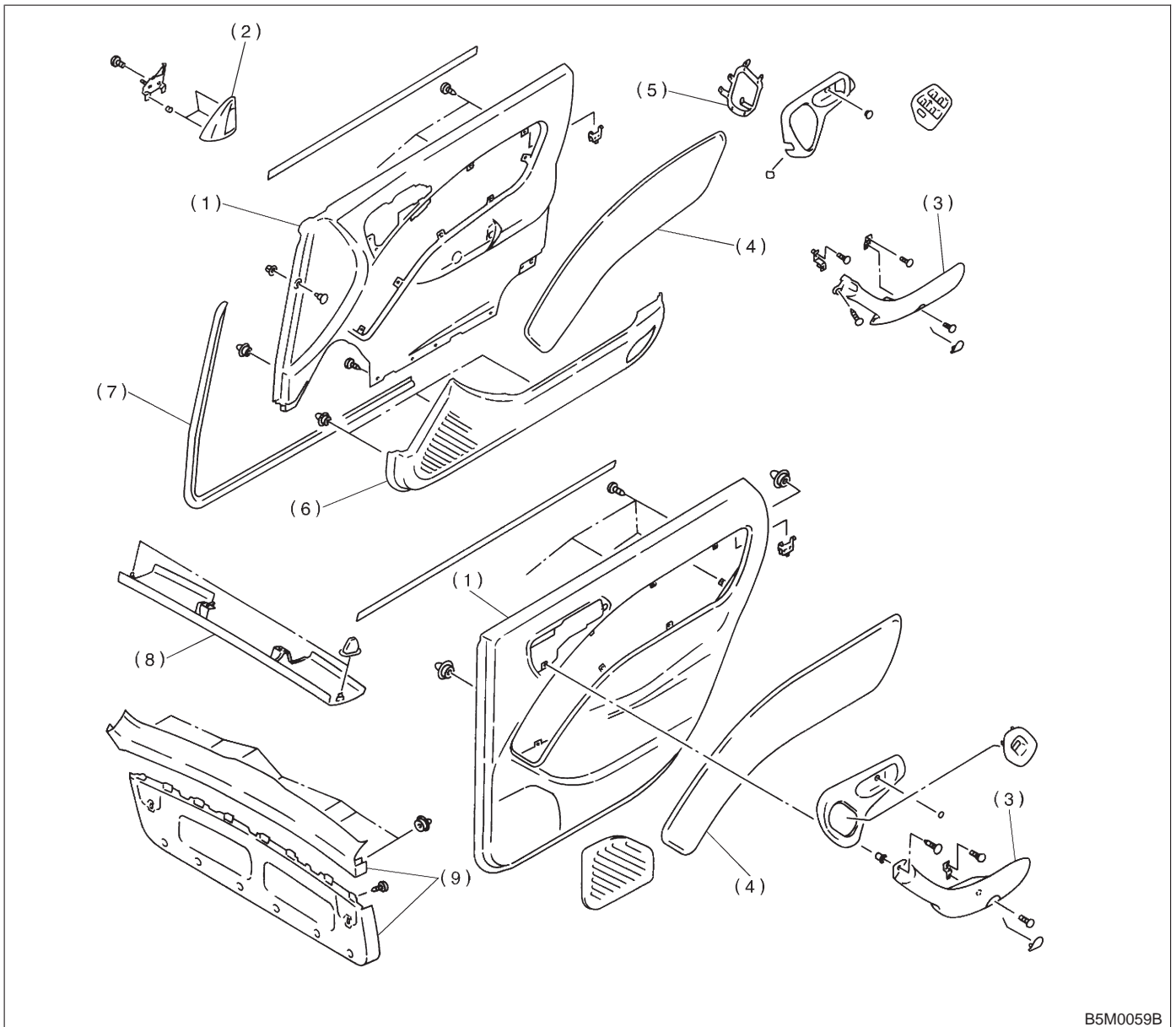

B5M0059B

- | | | |
|------------------|--------------|--------------------------|
| (1) Trim panel | (4) Ornament | (7) Weatherstrip |
| (2) Gusset cover | (5) Bracket | (8) Rear gate upper trim |
| (3) Arm rest | (6) Pocket | (9) Rear gate lower trim |

9. Weatherstrip

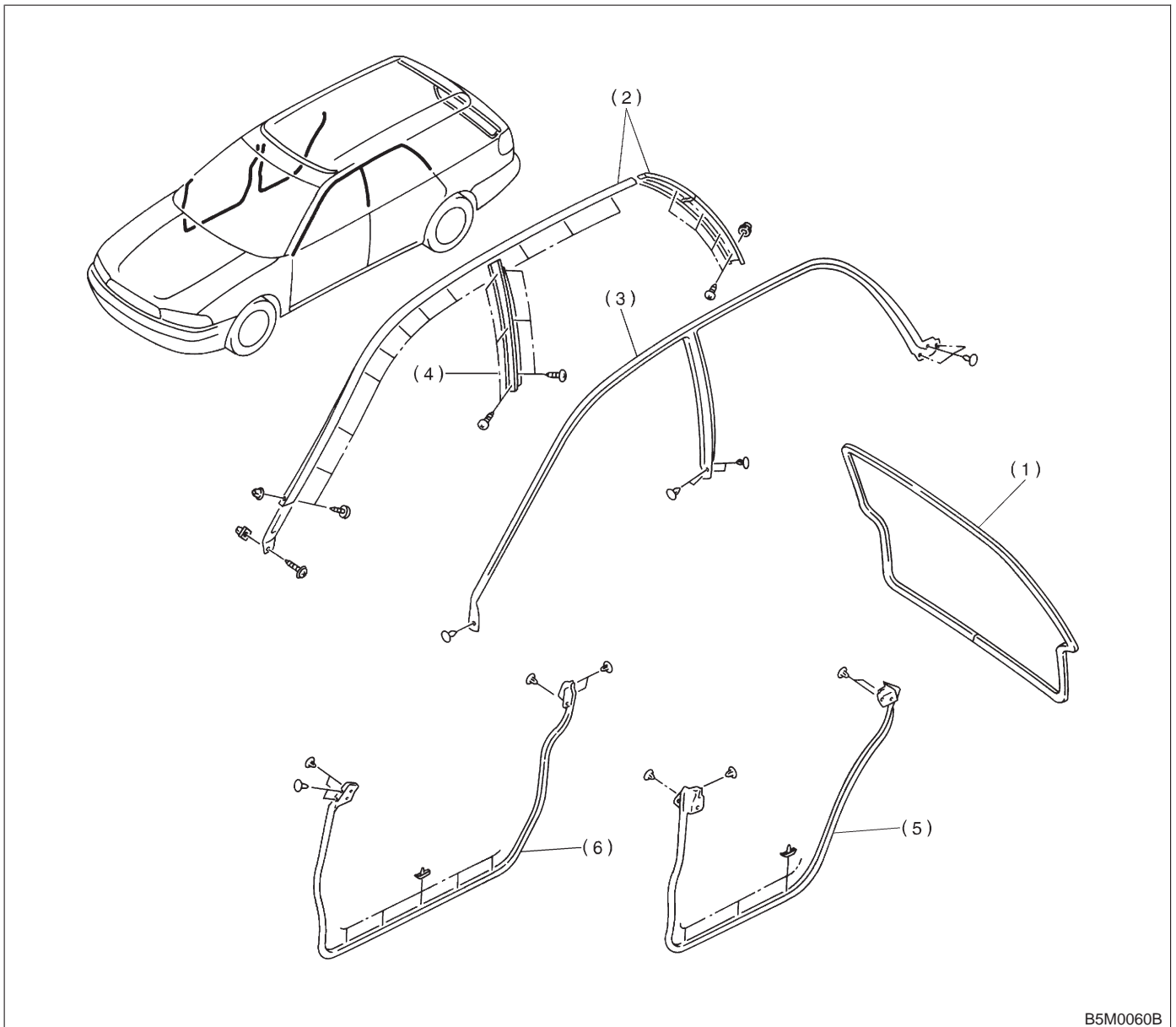

B5M0060B

(1) Rear gate weatherstrip
(2) Retainer and molding

(3) Upper and side weatherstrip
(4) Retainer (Center)

(5) Weatherstrip (Rear door)
(6) Weatherstrip (Front door)

1. Procedure Chart for Removing and Installing Door and Related Parts

NOTE:

This flow chart shows the main procedures for removing and installing the door and its related parts. For details, refer to the text.

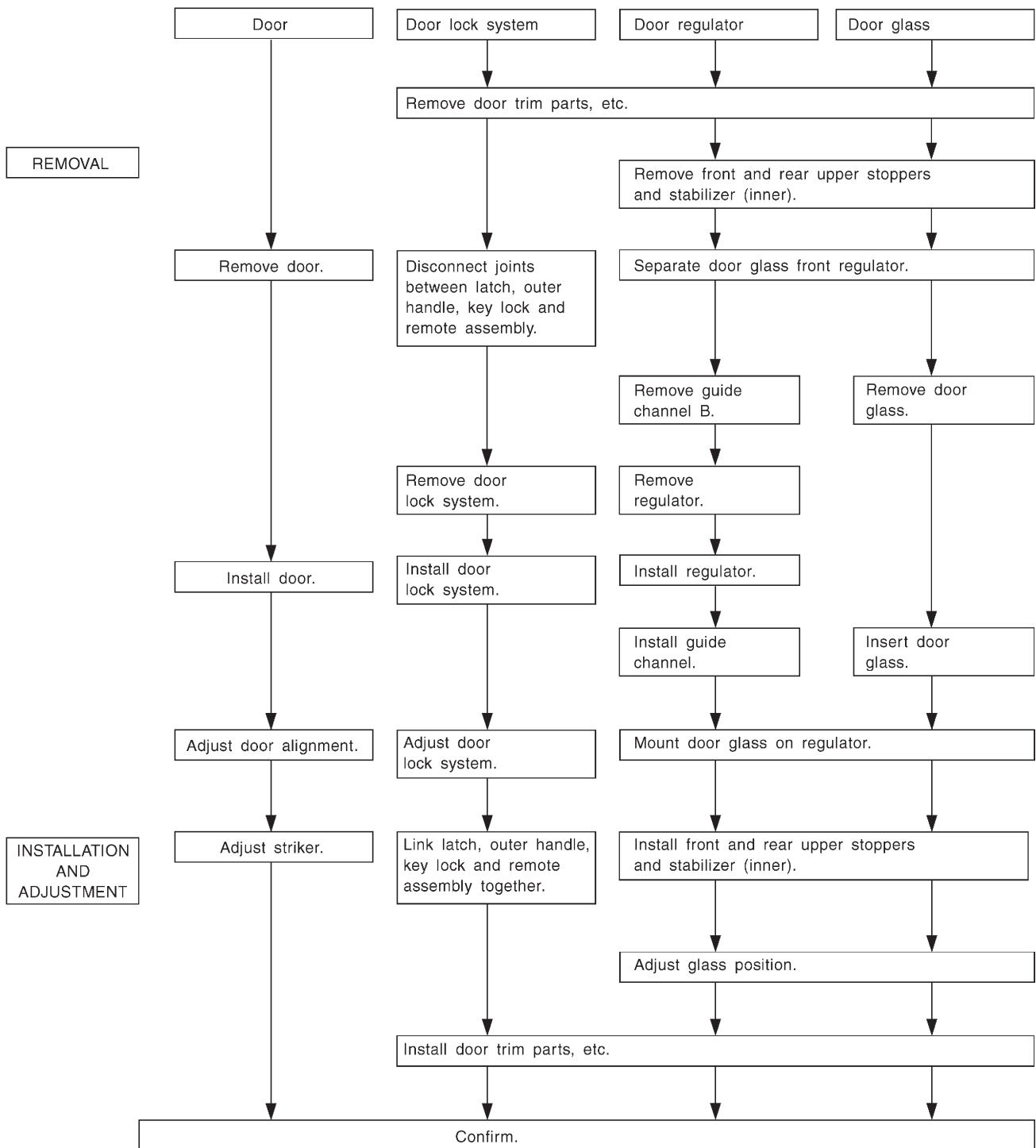

B5M0448A

2. Door

A: REMOVAL AND INSTALLATION

1. DOOR ASSEMBLY

1) Remove lower trim and disconnect connectors from body harness.

2) Place a cloth or a wood block under door to prevent damage, and support it with a jack.

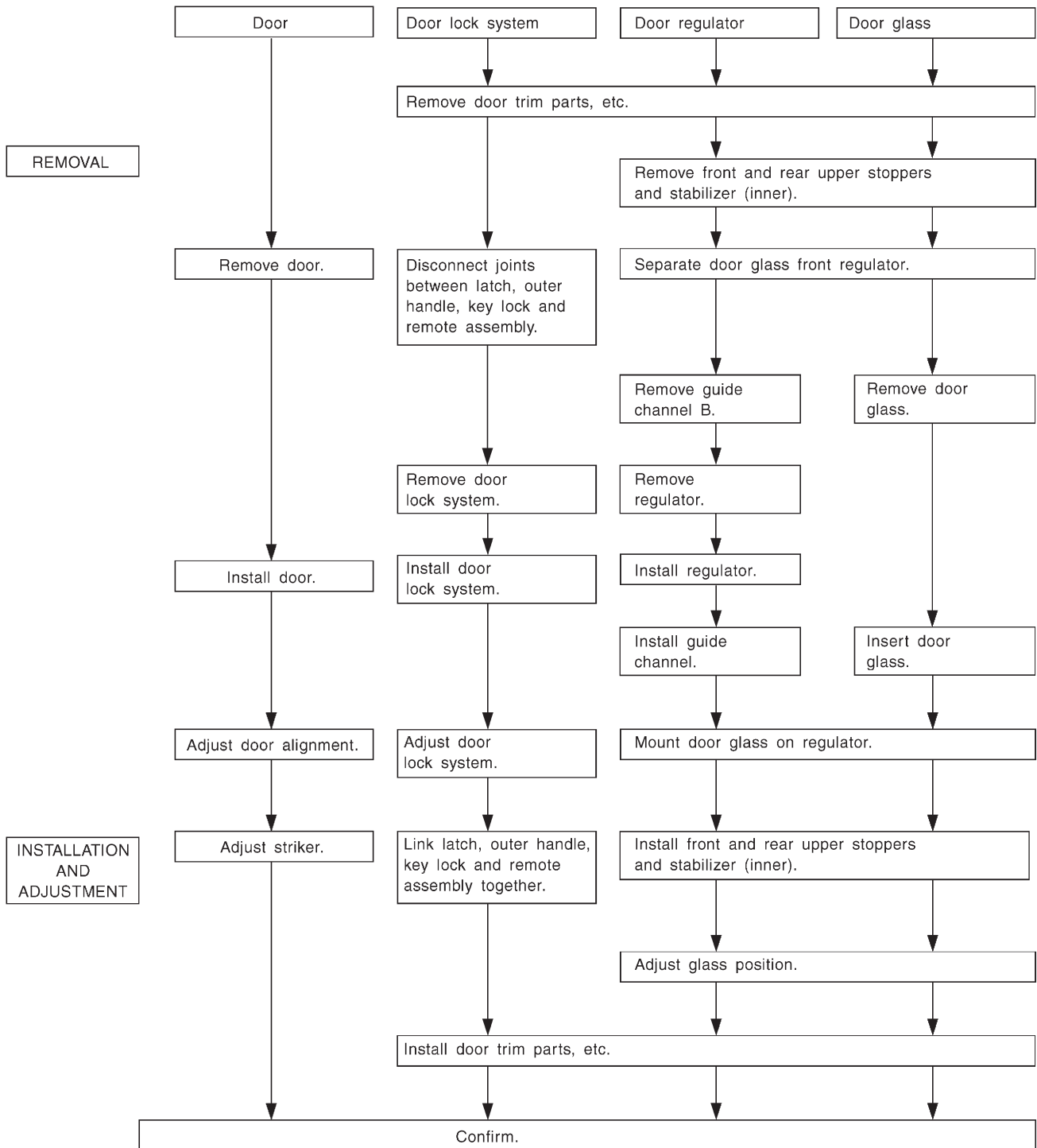

B5M0448A

2. Door

A: REMOVAL AND INSTALLATION

1. DOOR ASSEMBLY

1) Remove lower trim and disconnect connectors from body harness.

2) Place a cloth or a wood block under door to prevent damage, and support it with a jack.

3) Remove checker pin by driving it upward. Be careful not to damage door and body.

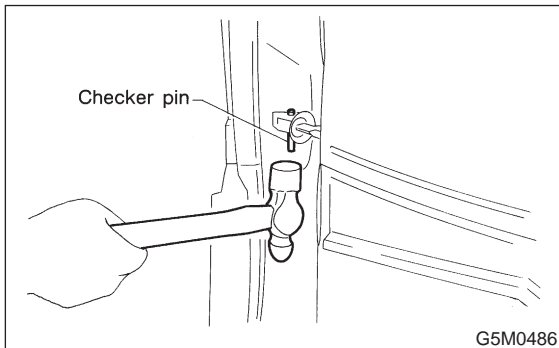

4) Remove bolts (M8) securing upper and lower hinges to door, and remove door from hinges.

Tightening torque:

$25 \pm 3 \text{ N}\cdot\text{m}$ ($2.5 \pm 0.3 \text{ kg}\cdot\text{m}$, $18.1 \pm 2.2 \text{ ft}\cdot\text{lb}$)

5) Remove hinges by loosening hinges mounting bolt (M8) off of body.

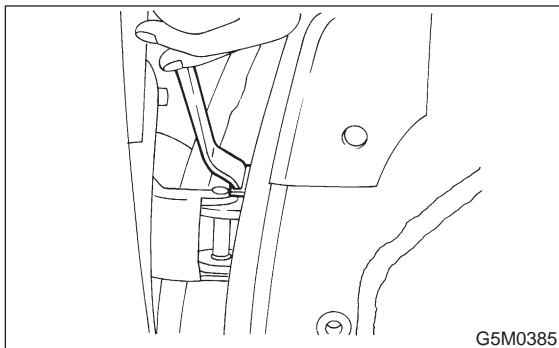

CAUTION:

Work carefully to avoid damaging door.

6) Installation is in the reverse order of removal.

Tightening torque:

$29 \pm 5 \text{ N}\cdot\text{m}$ ($3.0 \pm 0.5 \text{ kg}\cdot\text{m}$, $21.7 \pm 3.6 \text{ ft}\cdot\text{lb}$)

NOTE:

Apply grease to moving parts of door hinges.

2. TRIM PANEL

1) Press retainer spring (A) with a thin flat bladed screwdriver and then remove regulator handle (B). (models without power window)

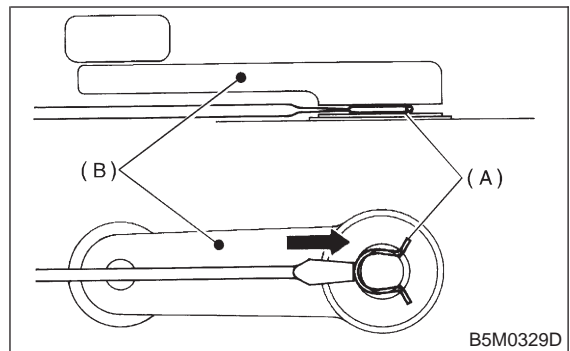

2) Remove gusset cover (A) and three screws.

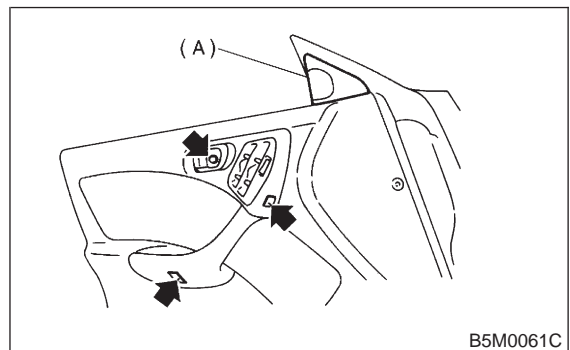

3) Using ST, disengage the clip.
ST 925580000 PULLER

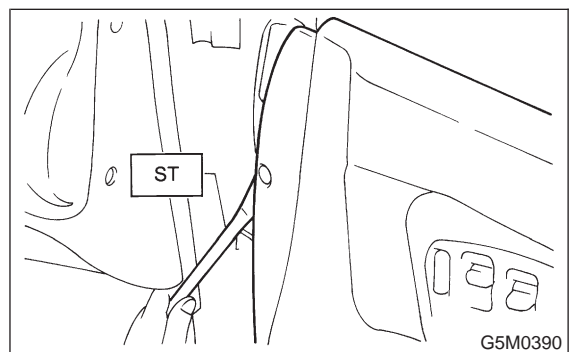

4) Remove trim panel and then disconnect connector. (models with power window)

CAUTION:

Be careful not to break clip by applying undue force.

5) Installation is in the reverse order of removal.

3. SEALING COVER

- 1) Remove trim panel. <Ref. to 5-2 [W2A2].>
- 2) Remove speaker, remote assembly and disconnect connectors.
- 3) Remove sealer with a spatula.

CAUTION:

Be careful because cover may break if sealer is removed forcefully.

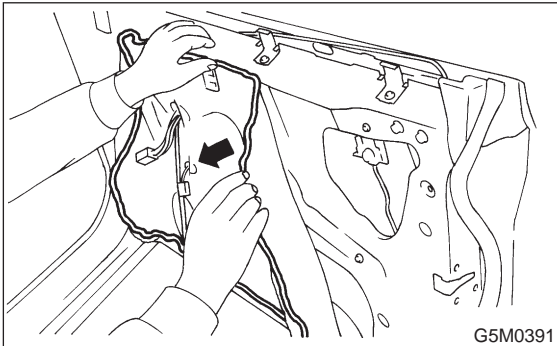

4) Installation is in the reverse order of removal.

NOTE:

- Confirm that sealer is properly applied without breaks. Then install sealing cover.
- When repairing or replacing sealing cover, use "CEMEDINE 5430L" as sealer. It may be overlaid on existing sealer.

Sealer:

CEMEDINE 5430L

CAUTION:

- Any breaks in sealer can cause water leakage or entry of air and dust. Be sure sealer is applied in a continuous line.
- Do not stop up drain hole (A) with sealer.
- Do not stop up install hole with (B) sealing cover.

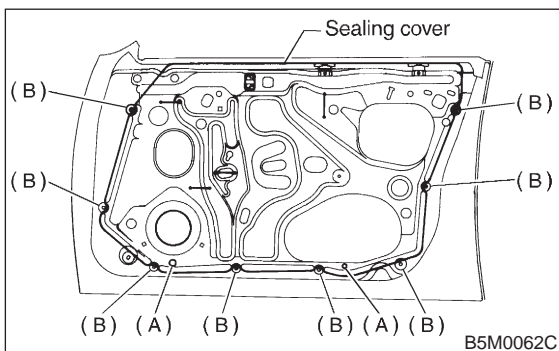

- Make sure sealing cover bonded areas are free from wrinkles or openings.

4. CHECKER

- 1) Remove trim panel. <Ref. to 5-2 [W2A2].>
- 2) Remove sealing cover. <Ref. to 5-2 [W2A3].>

- 3) Apply a cloth to door and body to prevent damaging them, and remove checker pin by driving it upward.

CAUTION:

Be careful not to damage door and body.

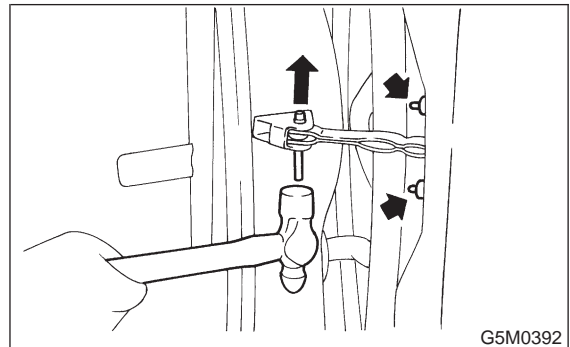

- 4) Completely close door glass.
- 5) Loosen two nuts securing checker, and take out checker through access hole in underside.
- 6) Installation should be made in the reverse order of removal.

Tightening torque:

7.4±2.0 N·m (0.75±0.2 kg·m, 5.4±1.4 ft·lb)

5. DOOR GLASS

- 1) Remove trim panel. <Ref. to 5-2 [W2A2].>
- 2) Remove sealing cover. <Ref. to 5-2 [W2A3].>
- 3) Disconnect door mirror connector and then remove gusset (A). <Ref. to 5-2 [W2A10].>

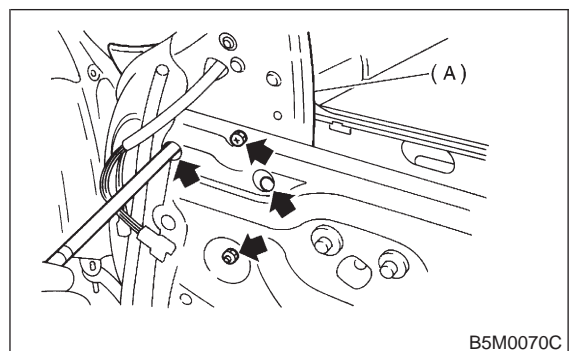

- 4) Remove inner remote. <Ref. to 5-2 [W2A6].>
- 5) Remove inner stabilizer (A).

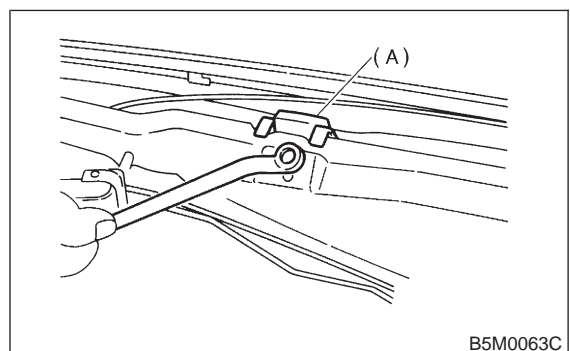

- 6) Remove nut and then separate glass holder (A) from guide channel A (B).

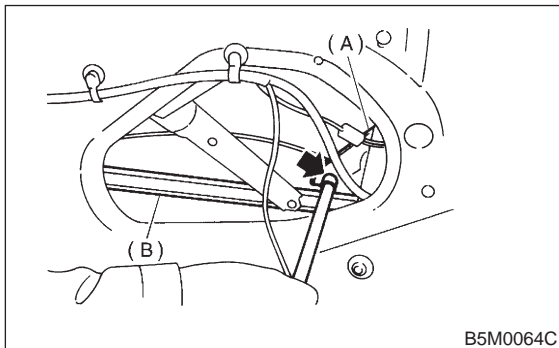

NOTE:

When removing nut, move door window lower glass connecting section to service hole of door panel.

- 7) Remove window glass upward.

CAUTION:

After removing window glass, do not move regulator.

- 8) Remove regulator installing bolt and guide channel B installing nut.

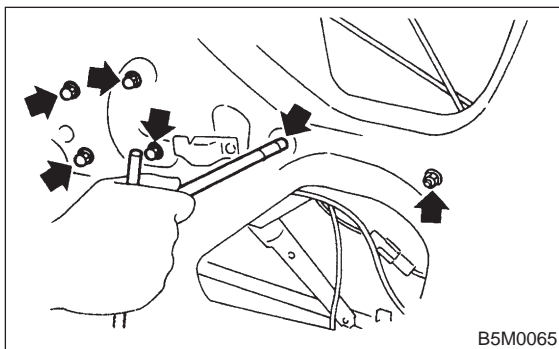

- 9) Remove regulator through lower service hole of door panel.

- 10) Installation is in the reverse order of removal.

6. INNER REMOTE

- 1) Remove trim panel. <Ref. to 5-2 [W2A2].>
- 2) Remove sealing cover. <Ref. to 5-2 [W2A3].>
- 3) Disconnect joints of two rods.

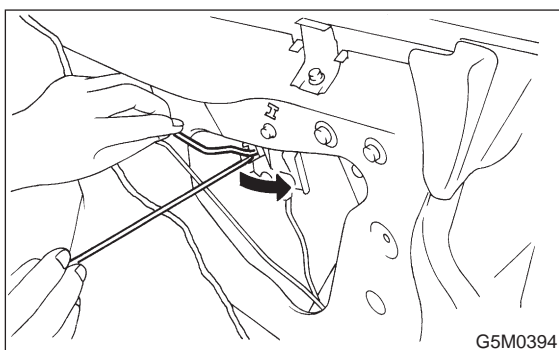

- 4) Unlatch rod holder.

- 5) Remove remote holder (A) and then remove inner remote assembly (B).

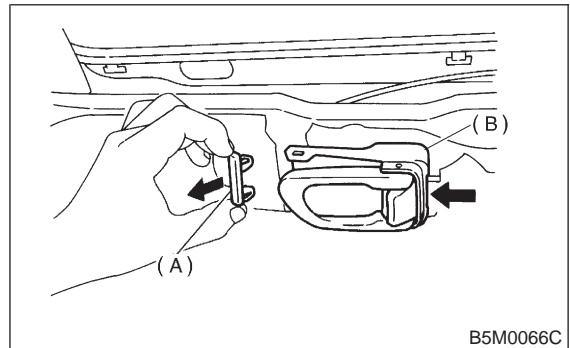

- 6) Installation is in the reverse order of removal.

NOTE:

- After passing two rods through holder, attach remote assembly to inner panel.
- Latch rod holder.

- 7) Lock the door and then loosen bolt (A).

- 8) Lower bell-crank (B) and then tighten bolt (A).

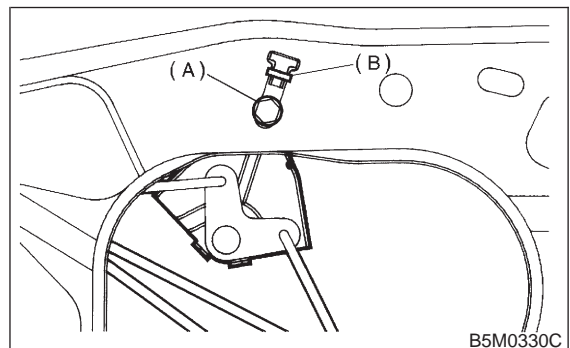

NOTE:

If rear door is equipped with child safety lock, check that child lock lever moves without dragging.

7. DOOR LATCH

- 1) Remove trim panel. <Ref. to 5-2 [W2A2].>
- 2) Remove inner remote assembly. <Ref. to 5-2 [W2A6].>
- 3) Remove sealing cover around latch service hole. <Ref. to 5-2 [W2A3].>
- 4) Completely close door glass.
- 5) Remove latch and actuator assembly:

- (1) Turn rod holder to disconnect joint between key lock and rod.
- (2) Turn rod holder to disconnect joint between outer handle and rod.
- (3) Turn rod holder to disconnect joint between crank and rod.

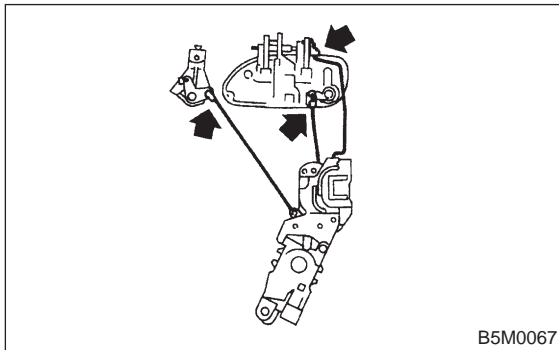

- 6) Loosen screws securing both latch and actuator, then remove latch and actuator assembly through service hole in bottom.

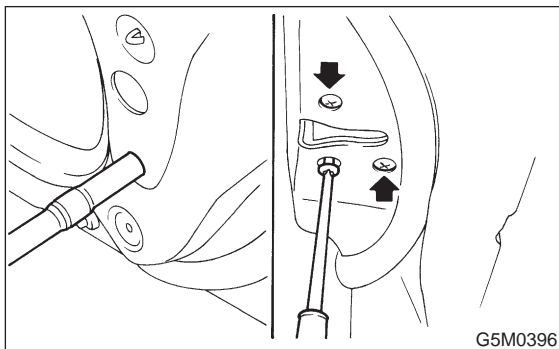

- 7) Installation is in the reverse order of removal.

Tightening torque:

$6.4 \pm 2.0 \text{ N}\cdot\text{m}$ ($0.65 \pm 0.2 \text{ kg}\cdot\text{m}$, $4.7 \pm 1.4 \text{ ft}\cdot\text{lb}$)

NOTE:

- Check operation of each part.
- Check each sliding part for proper lubrication.

CAUTION:

After installation, be sure lock mechanism operates normally.

8. OUTER HANDLE

- 1) Remove trim panel. <Ref. to 5-2 [W2A2].>
- 2) Remove sealing cover. <Ref. to 5-2 [W2A3].>
- 3) Detach door latch rod from outer handle and key lock.

- 4) Loosen nut securing outer handle and then remove outer handle from outside.

CAUTION:

Be careful not to damage door.

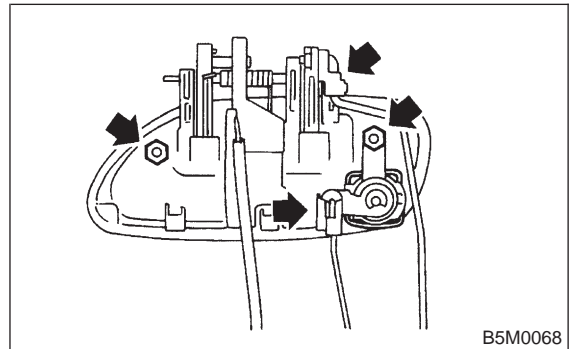

- 5) Installation is in the reverse order of removal.

Tightening torque:

$7.4 \pm 2.0 \text{ N}\cdot\text{m}$ ($0.75 \pm 0.2 \text{ kg}\cdot\text{m}$, $5.4 \pm 1.4 \text{ ft}\cdot\text{lb}$)

9. KEY LOCK

- 1) Remove trim panel. <Ref. to 5-2 [W2A2].>
- 2) Remove sealing cover. <Ref. to 5-2 [W2A3].>
- 3) Completely close door glass.
- 4) Remove outer handle. <Ref. to 5-2 [W2A8].>
- 5) Loosen spring (A) securing key lock.

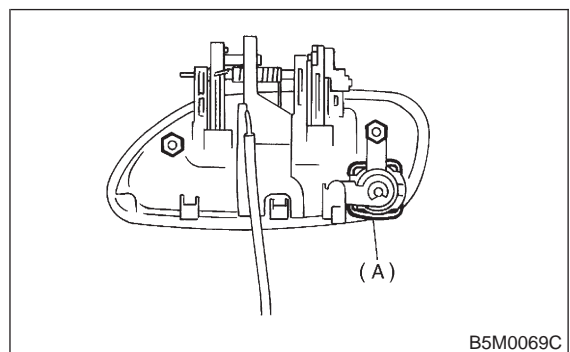

- 6) Remove key lock from outer handle.
- 7) Installation is in the reverse order of removal.

NOTE:

Install so that key slot in key lock comes to center of hole in outer handle.

10. GUSSET

- 1) Be sure window is all the way down.
- 2) Remove trim panel. <Ref. to 5-2 [W2A2].>
- 3) Remove door rearview mirror.
- 4) Remove sealing cover. <Ref. to 5-2 [W2A3].>
- 5) Remove bolts and nuts which secure gusset (A).
- 6) Lift out gusset (A).

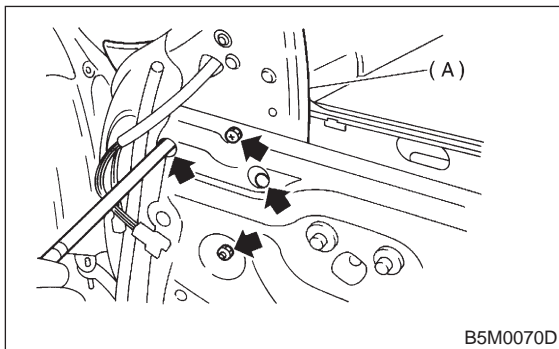

- 7) Installation is in the reverse order of removal.

11. REAR DOOR CATCHER

- 1) Open the rear door.
- 2) Using TORX®BIT (Tamper resistant type), remove rear door catcher.

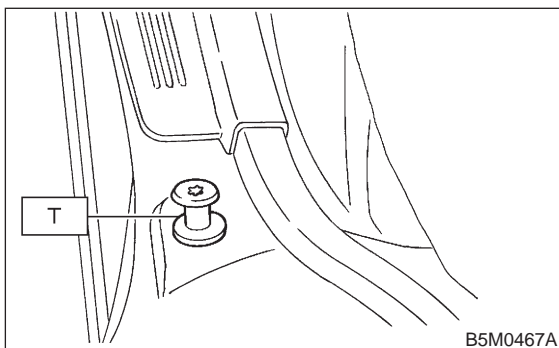

- 3) Installation is in the reverse order of removal.

Tightening torque:

$37 \pm 10 \text{ N}\cdot\text{m}$ ($3.8 \pm 1.0 \text{ kg}\cdot\text{m}$, $27.5 \pm 7.2 \text{ ft}\cdot\text{lb}$)

B: ADJUSTMENT

1. DOOR ASSEMBLY

- 1) Using ST, loosen bolts securing upper and lower hinges to body, and adjust fore-and-aft and vertical alignment of door.

ST 925610000 DOOR HINGE WRENCH

- 2) Loosen mounting screws approximately one rotation. Adjust striker (A) position by lightly tapping with hammer. (To adjust, utilize the shape of striker nut plate support (B).)

CAUTION:

- Use cloth to prevent damaging body or other parts.
- Do not directly tap striker plastic portion.
- Do not apply impact on spot-welded striker nut plate.

Hinge tightening torque (body side):

$29 \pm 5 \text{ N}\cdot\text{m}$ ($3.0 \pm 0.5 \text{ kg}\cdot\text{m}$, $21.7 \pm 3.6 \text{ ft}\cdot\text{lb}$)

Striker tightening torque:

$14 \pm 4 \text{ N}\cdot\text{m}$ ($1.4 \pm 0.4 \text{ kg}\cdot\text{m}$, $10.1 \pm 2.9 \text{ ft}\cdot\text{lb}$)

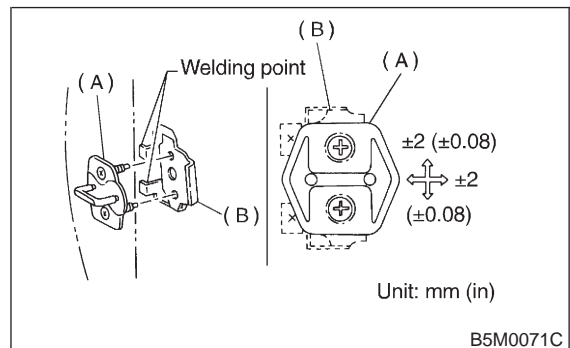

2. PROCEDURE CHART FOR ADJUSTING DOOR GLASS

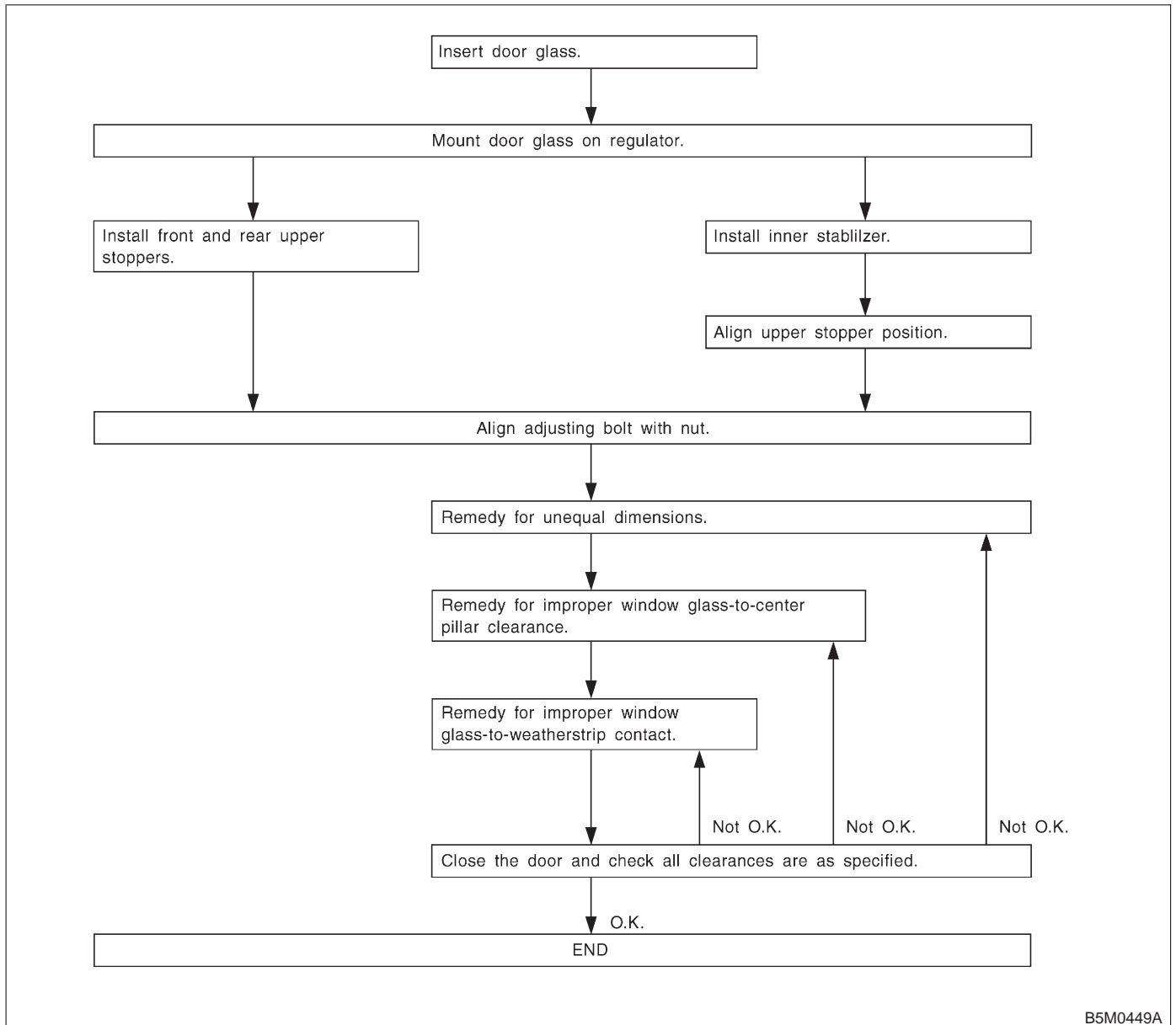

B5M0449A

3. FRONT DOOR GLASS

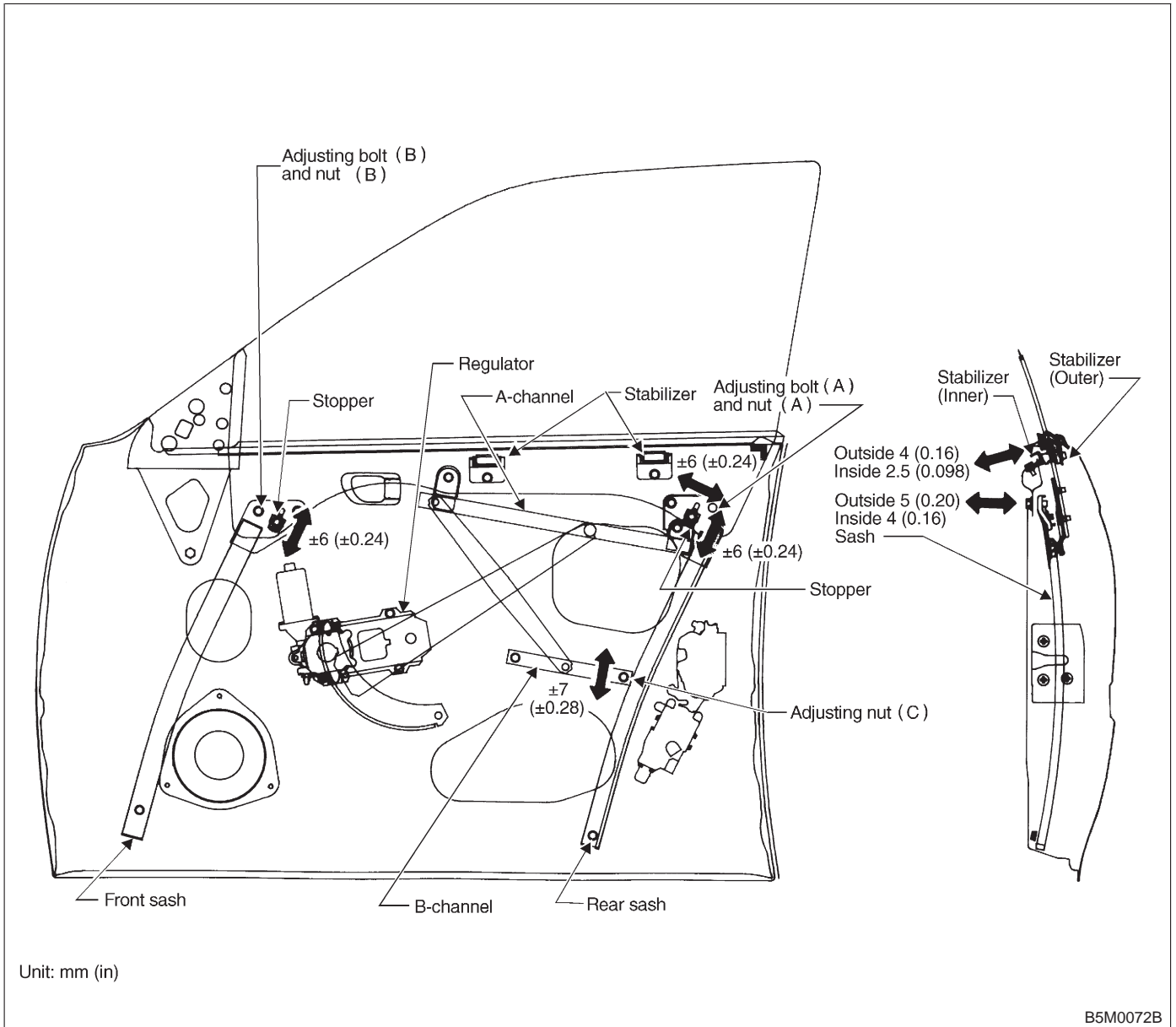

● Door glass fit adjustment

Before adjusting door glass alignment, ensure adjusting bolts for stabilizers, upper stoppers and sashes are loose and glass is raised so that it is in contact with upper and side weatherstrip.

1) Temporarily tighten one of the two rear sash adjusting bolts, at midpoint of oblong hole on inner panel.

2) Temporarily tighten B channel regulator at a position slightly lower than midpoint of oblong hole on inner panel.

3) Lower door glass 10 to 15 mm (0.39 to 0.59 in) from fully closed position. While applying outward pressure (load) to upper edge of glass above mid-point of two outer stabilizers, press inner stabilizer until it just touches the glass, then secure it.

Load: F

Front door glass 39 N (4 kg, 9 lb)

Rear door glass 34.3 N (3.5 kg, 7.7 lb)

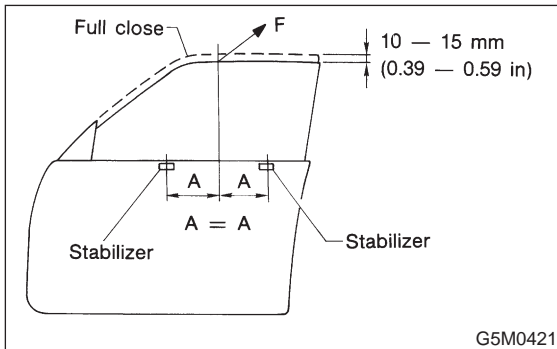

● Remedy for unequal dimensions, between upper, lower and center pillar sides

- 1) Close front door and raise door glass
- 2) Make sure of unequal dimensions.

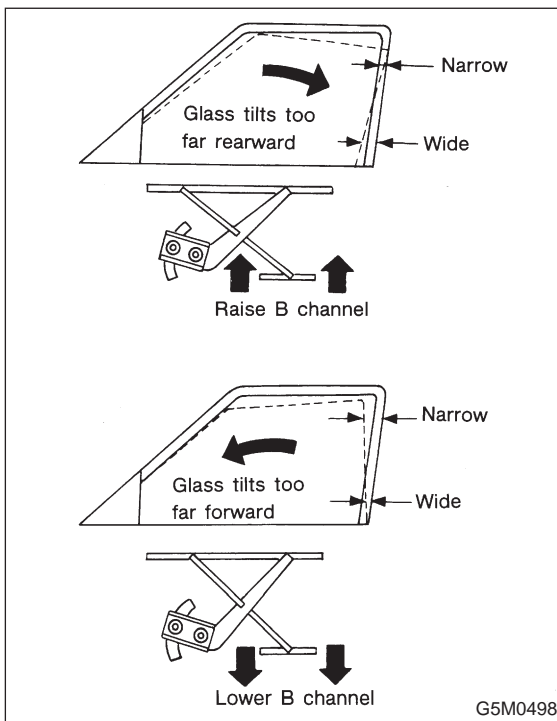

3) If glass tilts to far rearward, loosen adjusting nut (C) and adjust glass to be parallel with center pillar, then after adjustment, tighten adjusting nut (C).

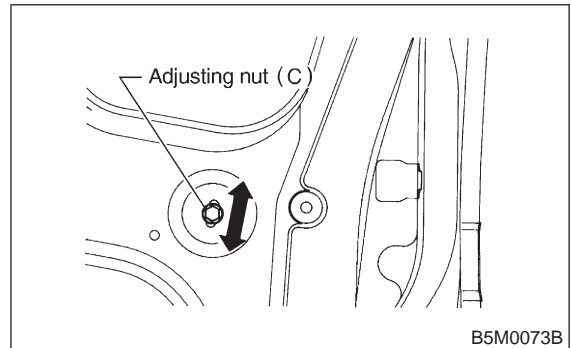

● Remedy for improper glass to center pillar clearance

- 1) Close front door and raise door glass
- 2) Make sure of improper clearance.

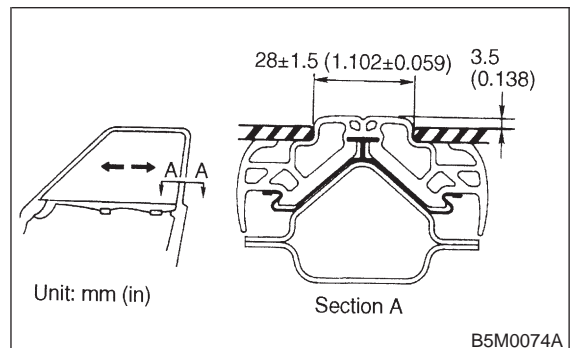

3) If clearance is improper, loosen adjusting nut (A), bolt (A) and adjust glass to center pillar.

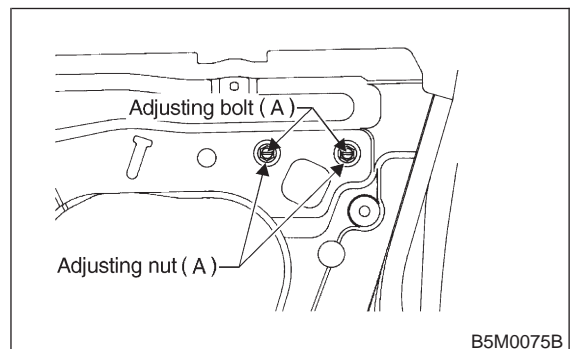

● Remedy for improper upper stop point of door glass

- 1) Loosen front and rear sash stoppers.

2) Increase the upward travel of window glass up to the position where upper edge just touches weatherstrip surface with door closed.

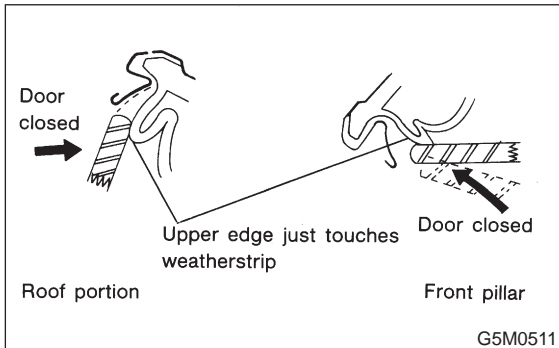

3) After adjustment, temporarily tighten stoppers.

NOTE:

Make sure that each glass stopper is touched.

● **Remedy for incorrect contact of door glass to weatherstrip**

- 1) Close front door and raise door glass.
- 2) If clearance is below specifications, loosen bolt (A) and bolt (B).
- 3) If clearance is over specifications, tighten bolt (A) and bolt (B).

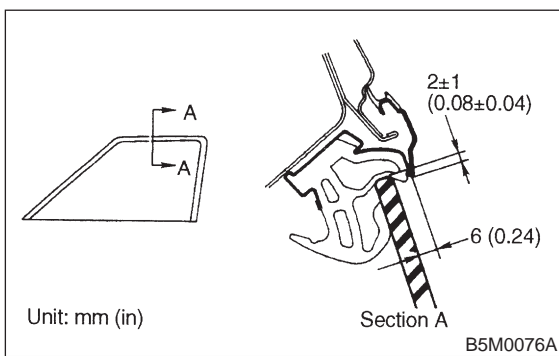

● **Fit adjustment**

Door glass fit is adjusted by displacing the glass front edge with a stabilizer.

NOTE:

Before adjusting glass fit, visually check to determine relative adjusting positions of retainer and molding (on roof side) and glass surface.

1) Alternately adjust two rear sash adjusting bolts (A) until dimensions (indicated in figure) are obtained.

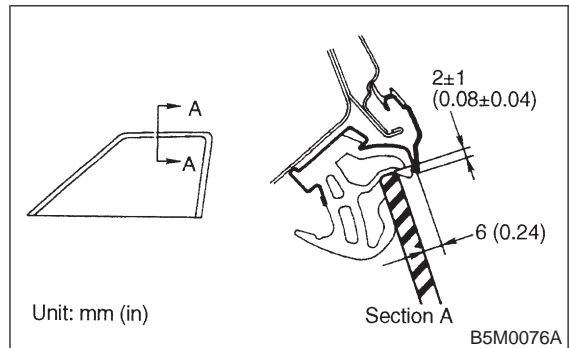

CAUTION:

Do not loosen two adjusting nuts (A) at the same time, as this moves sash fore and aft, creating unequal glass-to-sash clearance. During adjustment, loosen only one nut and keep the other tightened.

NOTE:

Always adjust two rear sash adjusting bolts (A) by the same amount. Do not adjust the adjusting bolts with sash bracket inclined toward inner panel, as this increases effort required to operate regulator.

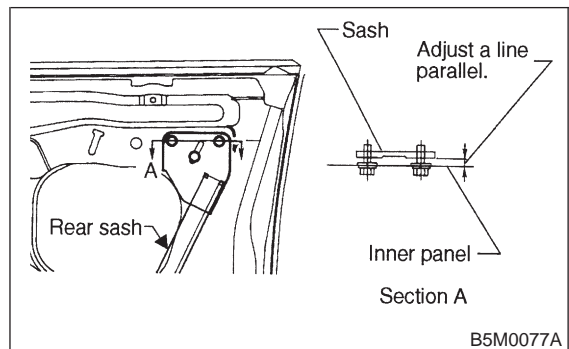

2) Adjust front sash fit using rear sash adjustment procedure outlined above as a guide. Two adjusting bolts must be adjusted by the same amount.

NOTE:

Front and rear sash adjustment procedures are basically the same; however, the amount of adjustment is not always the same due to alignment dispersion of individual doors. Adjust front and rear sash fit, as equally as possible. Otherwise, effort required to operate regulator may increase.

3) After adjusting front sash-to-glass fit, secure front sash.

4. REAR DOOR GLASS

Alignment of rear door glass is basically the same as for the front door glass. Due to slight difference in adjustment dimensions for fore-aft, up-down, and in-out alignments, key points for rear door adjustment are described.

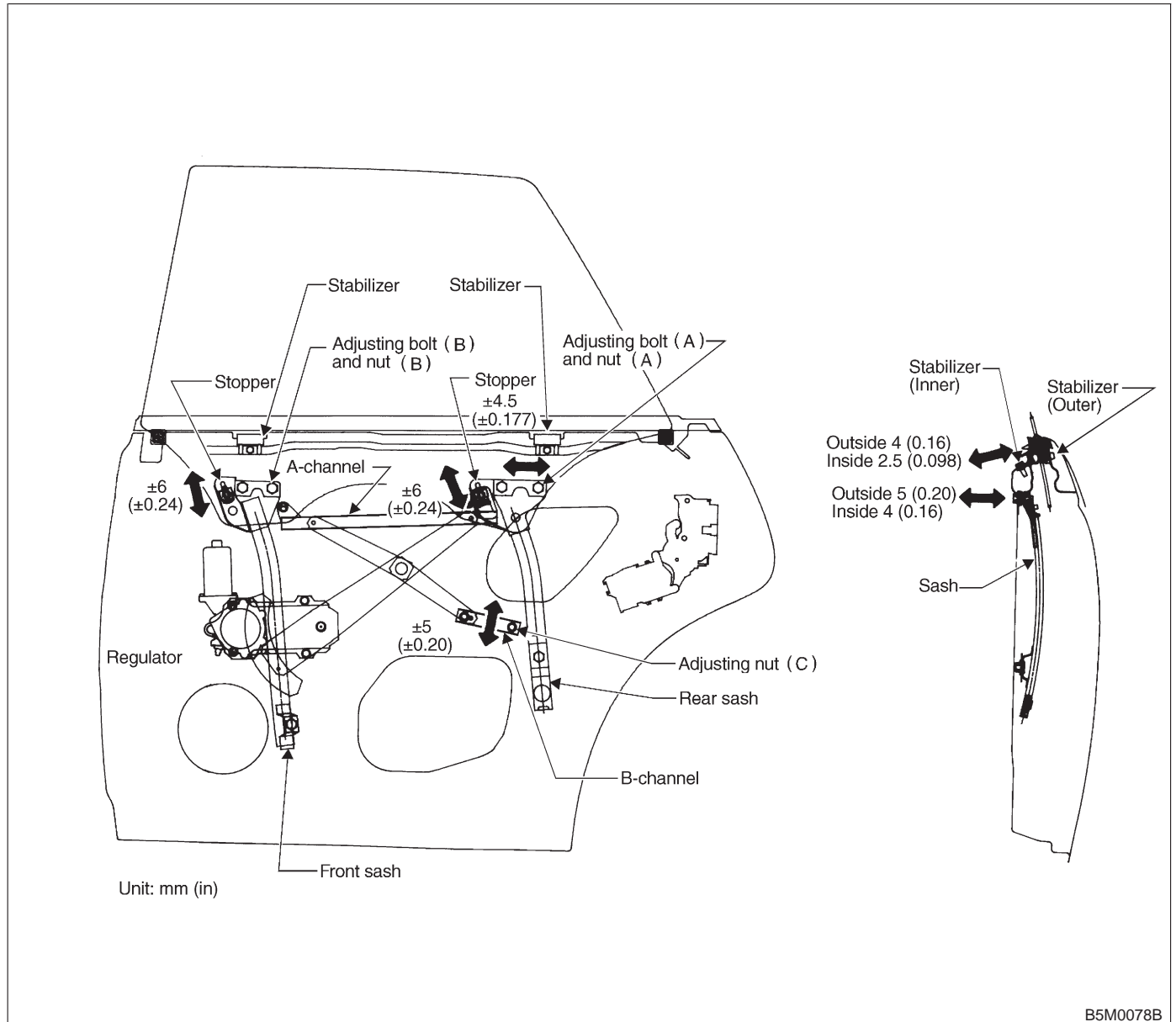

● **Fore-aft adjustment**

1) Door glass alignment must be adjusted so that glass- to-center pillar fit is equal at all points.

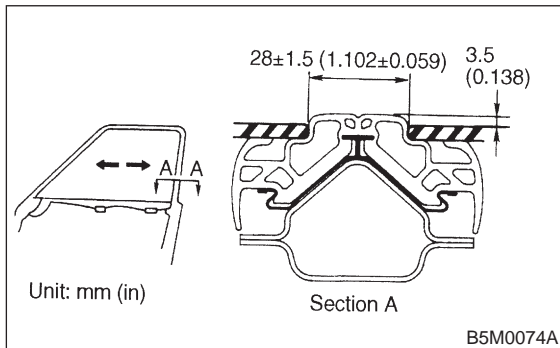

NOTE:

If dimensions are smaller than those indicated, glass will be caught in weatherstrip and may not raise to the fully closed position.

2) After making fore-aft adjustment, raise and lower glass to ensure it is free from any binding.

C: INSPECTION

1. FRONT AND REAR DOOR GLASS

1) Close front door and make sure of all clearances.

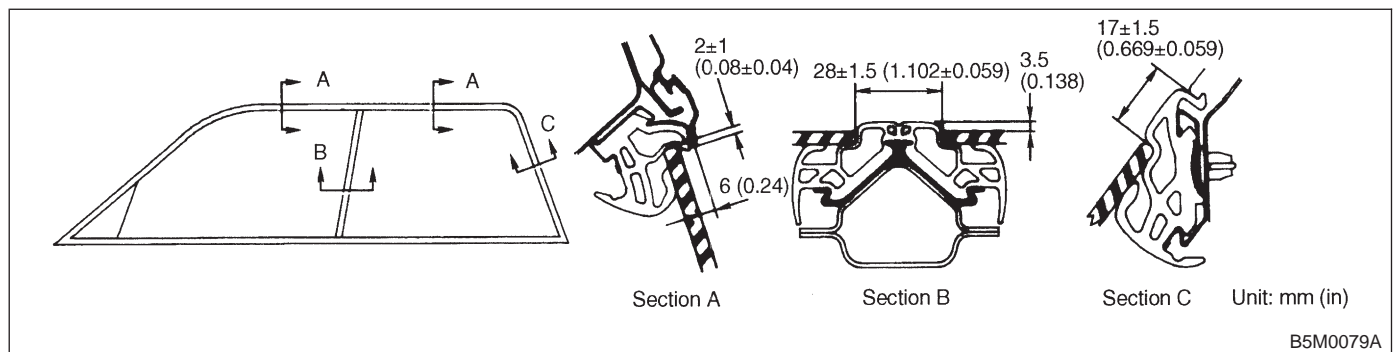

2) If any clearance is not correct, adjust affected parts. Re-check all clearances.

CAUTION:

- Repeatedly adjust parts until all clearances are correct.
- After clearance adjustment, make sure that all adjusting bolts and nuts are tightened.

● **Fit adjustment**

Increasing contact pressure causes rear door glass to be caught in center pillar upper and lower weatherstrip; this will cause premature weatherstrip wear.

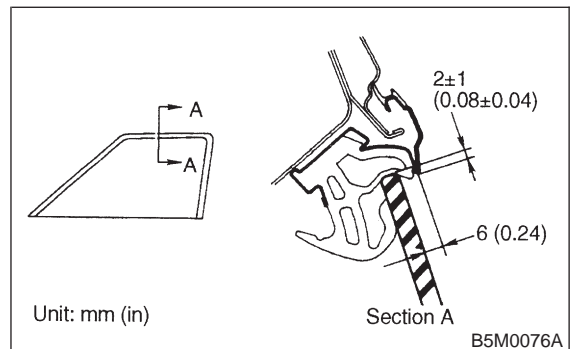

3. Rear Gate

A: REMOVAL AND INSTALLATION

CAUTION:

- Be careful not to scratch coated surfaces of vehicle body and window glass during removal. Place a cloth over the affected area.
- Be careful not to damage trim panels.
- Use an assistant when handling heavy parts.
- Be careful not to damage or lose small parts.

● **Fore-aft adjustment**

1) Door glass alignment must be adjusted so that glass- to-center pillar fit is equal at all points.

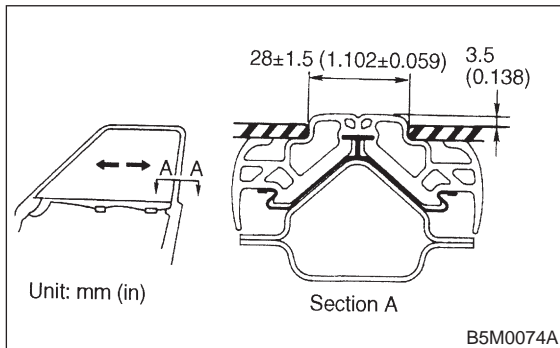

NOTE:

If dimensions are smaller than those indicated, glass will be caught in weatherstrip and may not raise to the fully closed position.

2) After making fore-aft adjustment, raise and lower glass to ensure it is free from any binding.

C: INSPECTION

1. FRONT AND REAR DOOR GLASS

1) Close front door and make sure of all clearances.

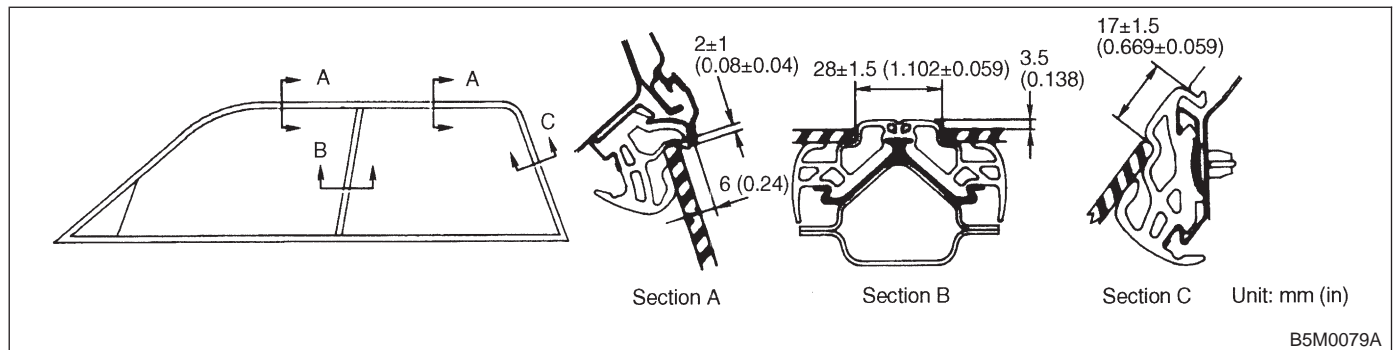

2) If any clearance is not correct, adjust affected parts. Re-check all clearances.

CAUTION:

- Repeatedly adjust parts until all clearances are correct.
- After clearance adjustment, make sure that all adjusting bolts and nuts are tightened.

● **Fit adjustment**

Increasing contact pressure causes rear door glass to be caught in center pillar upper and lower weatherstrip; this will cause premature weatherstrip wear.

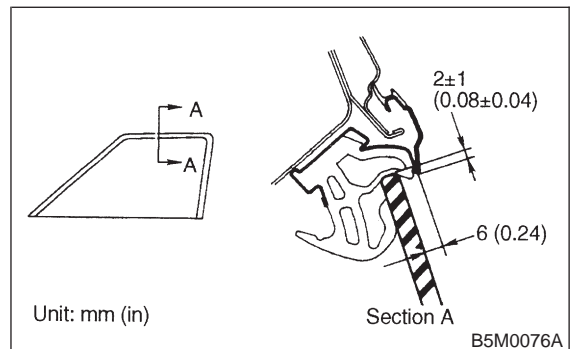

3. Rear Gate

A: REMOVAL AND INSTALLATION

CAUTION:

- Be careful not to scratch coated surfaces of vehicle body and window glass during removal. Place a cloth over the affected area.
- Be careful not to damage trim panels.
- Use an assistant when handling heavy parts.
- Be careful not to damage or lose small parts.

1. REAR GATE ASSEMBLY

1) Remove clips from trim panel and detach trim panel.

CAUTION:

Be careful not to damage clips or their holes.

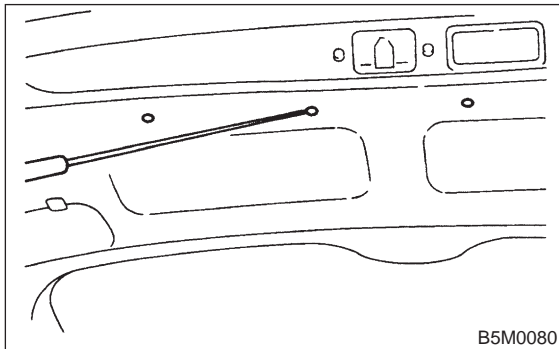

- 2) Disconnect rear washer hose from wiper motor.
- 3) Remove high-mount stop light.
- 4) If disconnected harness is re-used, tie connector with a string and place on the upper side of rear gate for ready use.
- 5) Remove both rubber ducts and then extract washer hose and harness connector.

CAUTION:

Do not forcefully pull cords, lead wires, etc. since damage may result; carefully extract them in a wavy motion while holding connectors.

- 6) Remove both rubber ducts and then extract washer hose and harness connector.
- 7) Gas stay
 - (1) Completely open rear gate.
 - (2) Remove bolts which hold gas stay to rear gate.

CAUTION:

- Be careful because rear gate drops while removing bolts. Have an assistant support it while removing bolts.
- Be sure to place a folded cloth between rear gate and body to prevent scratches.

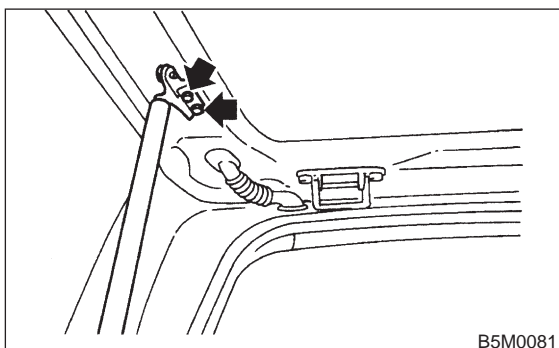

8) Remove the bolts which hold rear gate to hinge and then detach rear gate.

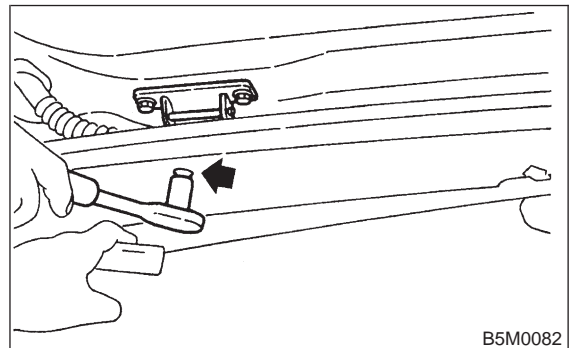

9) General precautions in handling rear gate gas stay.

CAUTION:

- Do not attempt to disassemble gas stay because its cylinder is filled with gas.
- Before discarding gas stay, place it at a slight angle with the cylinder body side facing up and drill a 2 to 3 mm (0.08 to 0.12 in) dia. hole to completely discharge the content. (Gas is odorless, colorless and harmless; however, metal powder may come out of the hole.)

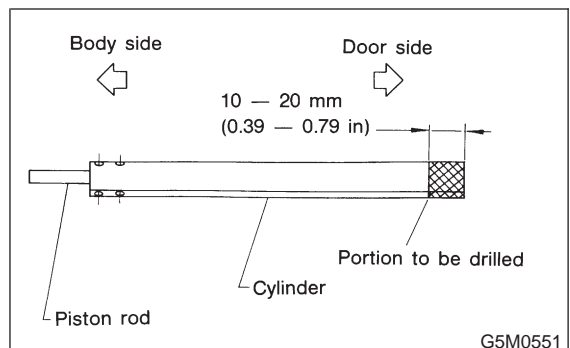

- It is good practice to place a vinyl sack over it before drilling the hole because oil may spurt out. Be careful to prevent vinyl cover from becoming entangled on the drill.

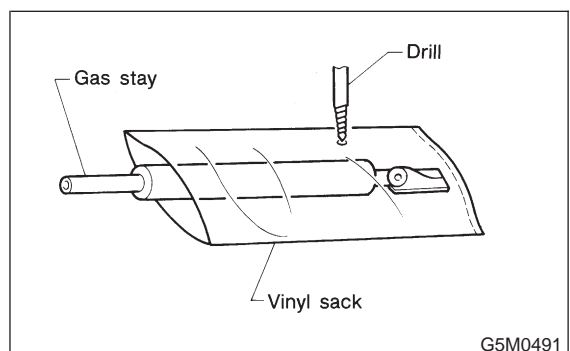

- Be careful not to scratch the exposed section of piston rod or allow oil or paint to come in contact with it.

- Do not attempt to rotate the extended piston rod.

10) Installation is in the reverse order of removal.

CAUTION:

- Be sure to add sealer to hinge.
- When installing rear gate, be careful not to damage coating on body and rear gate.

2. LATCH

- 1) Remove trim panel.
- 2) Disengage rod from holder (= key cylinder).
- 3) Remove bolts from auto-door lock actuator.
- 4) Remove bolts from latch, and detach latch.

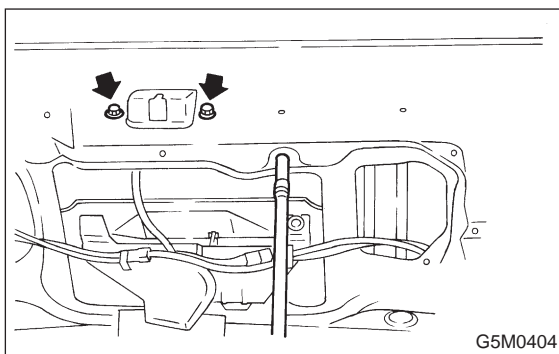

- 5) Disconnect rear gate switch connector.
- 6) Disconnect auto-door lock actuator connector.
- 7) Detach latch.
- 8) Installation is in the reverse order of removal.

3. OUTER HANDLE

- 1) Remove trim panel.
- 2) Disconnect rod from outer handle.
- 3) Remove two nuts used to hold outer handle to the inside of rear gate, and detach outer handle.

CAUTION:

Be careful not to damage packing when removing outer handle.

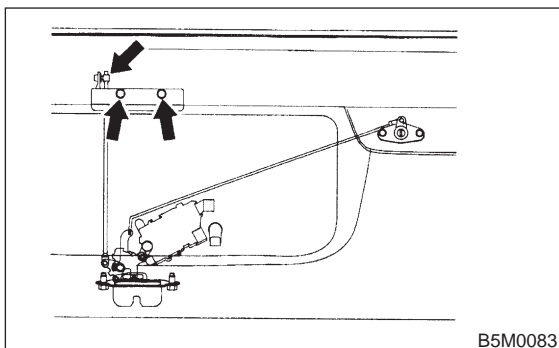

- 4) Installation is in the reverse order of removal.

4. KEY CYLINDER

- 1) Remove trim panel.

- 2) Disengage rod from holder (A).
- 3) Remove nut from key cylinder, and detach key cylinder.

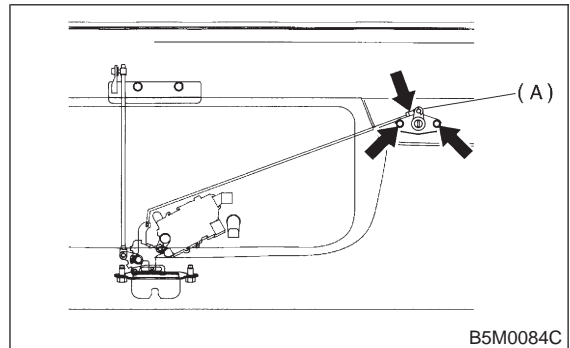

- 4) Installation is in the reverse order of removal.

5. STRIKER

- 1) Remove two bolts from striker and detach striker.

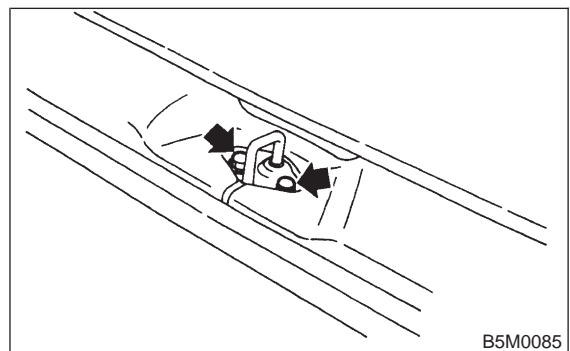

- 2) Installation is in the reverse order of removal.

6. WEATHERSTRIP

- 1) Place weatherstrip so that its joints meet at lower center of vehicle body, and install by inserting flanged portion from below, as shown in section A—A in figure.

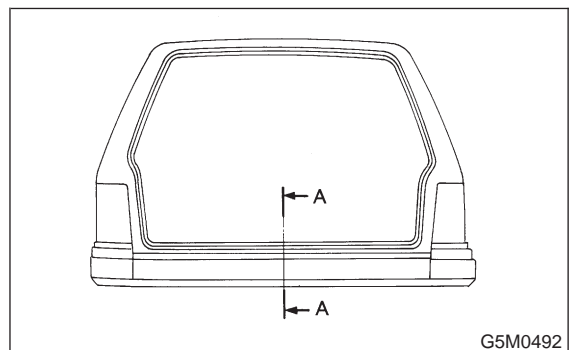

5-2 [W3B0]

3. Rear Gate

SERVICE PROCEDURE

2) Tap along entire length with a rubber hammer to firmly insert body flange into weatherstrip.

CAUTION:

- Be careful not to install in wrong direction.
- Install weatherstrip carefully and firmly.

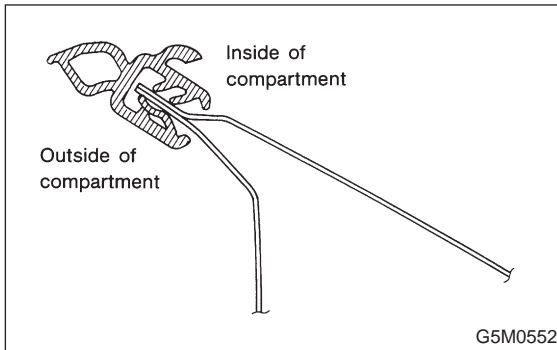

B: ADJUSTMENT

- 1) Loosen striker screw.
- 2) For lateral adjustment, align striker and latch at their centers.

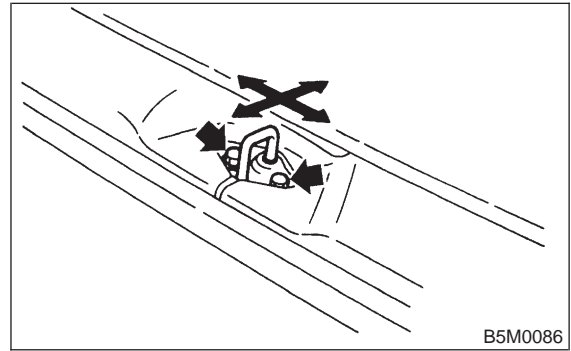

4. Procedure Chart for Removing and Installing Window Glass

A: REMOVAL AND INSTALLATION

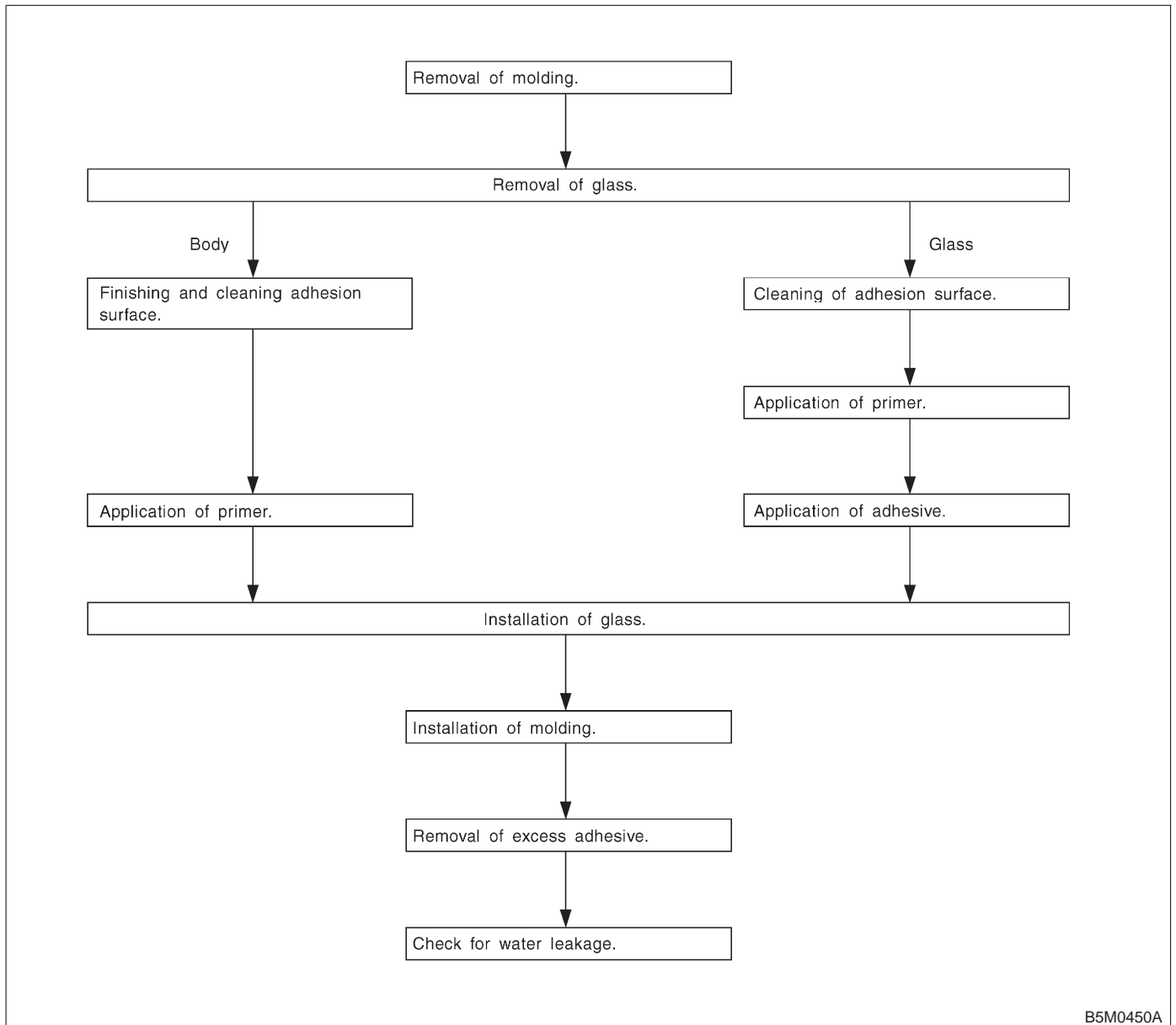

B5M0450A

B: MATERIALS REQUIRED FOR APPLICATION

Description	Remarks
Repair adhesive set ● Cartridge of single liquid urethane adhesive ● Primer for glass and body	Sunstar No. 580 or Essex Chemical Corp's Urethane E Sunstar No. 435-580
Windshield knife or piano wire	For cutting windshield.
Sealant gun	For applying adhesive.
Suction cups	For holding glass.
Putty knife	For finishing adhesion surface and cutting spacer.
Sponge	For applying primer.
Gauze or cloth	For cleaning.
Alcohol or white gasoline	Alcohol or white gasoline For cleaning adhesion surface.
Tape	For preventing damage to painted surface.

5. Windshield

A: REMOVAL

1. USING WINDSHIELD KNIFE

The following procedure for the front windshield can also be applied to other window glass.

- 1) Remove wiper arm and cowl panel.
- 2) Remove front side molding and front molding upper.

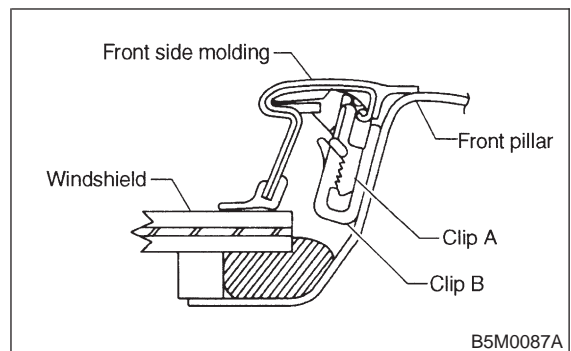

3) Remove glass:

- (1) Put protective tape on body to prevent damage.
- (2) Apply soapy water to the surface of the adhesive agent so the knife blade slides smoothly.
- (3) Cut off excess adhesive agent.
- (4) Put windshield knife into layer of adhesive
- (5) Cut adhesive layer with the windshield knife.

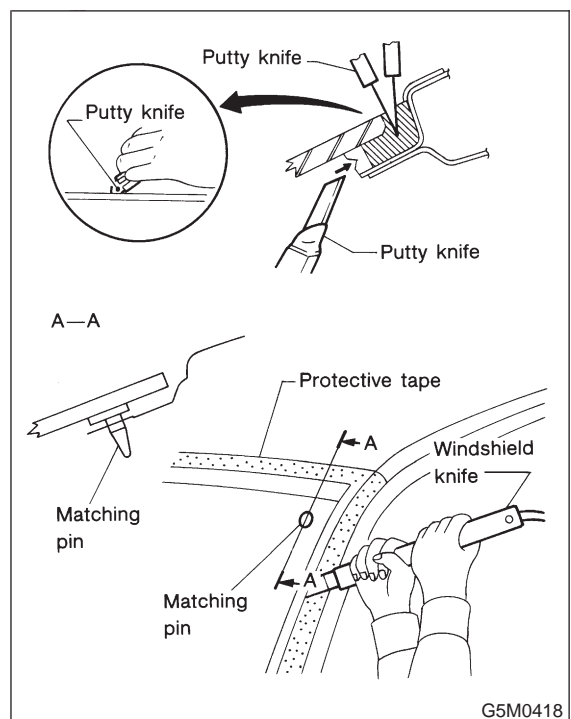

B: MATERIALS REQUIRED FOR APPLICATION

Description	Remarks
Repair adhesive set ● Cartridge of single liquid urethane adhesive ● Primer for glass and body	Sunstar No. 580 or Essex Chemical Corp's Urethane E Sunstar No. 435-580
Windshield knife or piano wire	For cutting windshield.
Sealant gun	For applying adhesive.
Suction cups	For holding glass.
Putty knife	For finishing adhesion surface and cutting spacer.
Sponge	For applying primer.
Gauze or cloth	For cleaning.
Alcohol or white gasoline	Alcohol or white gasoline For cleaning adhesion surface.
Tape	For preventing damage to painted surface.

5. Windshield

A: REMOVAL

1. USING WINDSHIELD KNIFE

The following procedure for the front windshield can also be applied to other window glass.

- 1) Remove wiper arm and cowl panel.
- 2) Remove front side molding and front molding upper.

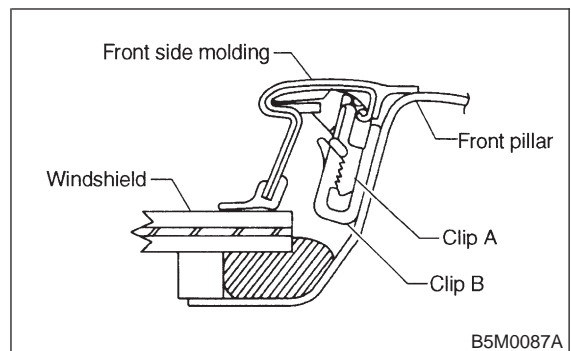

3) Remove glass:

- (1) Put protective tape on body to prevent damage.
- (2) Apply soapy water to the surface of the adhesive agent so the knife blade slides smoothly.
- (3) Cut off excess adhesive agent.
- (4) Put windshield knife into layer of adhesive
- (5) Cut adhesive layer with the windshield knife.

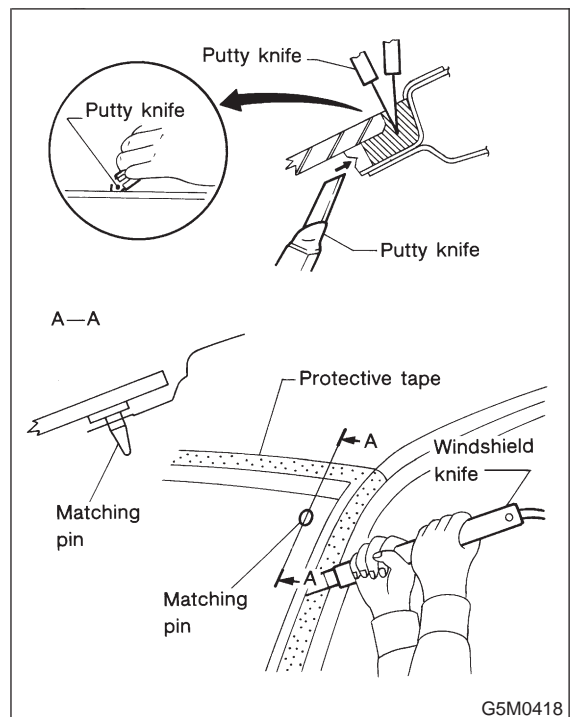

CAUTION:

- Keep knife edge along glass surface and end face.
- When first putting knife into layer of adhesive, select point with wide gap between body and glass.

NOTE:

A matching pin is cemented to corners of glass on compartment side.
Use a piano wire when cutting each pin.

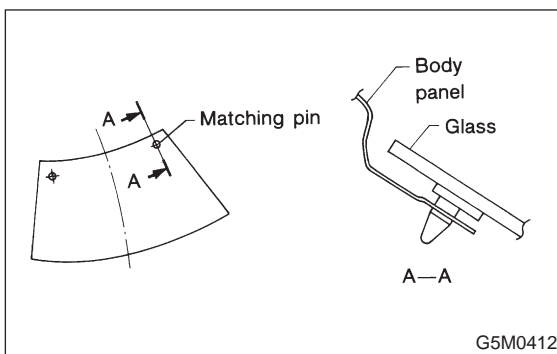

2. USING PIANO WIRE

- 1) Remove wiper arm and cowl panel.
- 2) Remove front side molding and front molding upper.

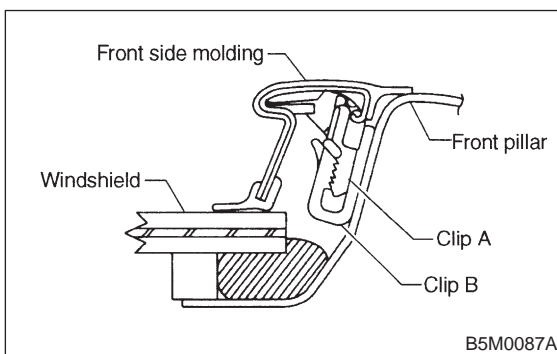

- 3) Remove glass:
 - (1) Put protective tape on body to prevent damage.
 - (2) Using drill or putty knife, make through-hole (one place) in adhesive agent.

- (3) Pass piano wire through the hole from inside the compartment, and connect both ends of wire securely to wooden blocks.

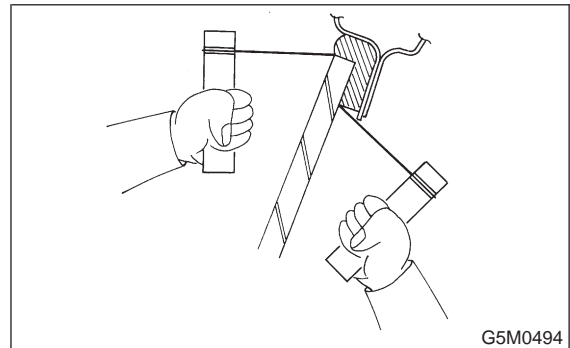

- (4) Cut adhesive layer with the wire by pulling it back and forth.

CAUTION:

When making through-hole into adhesive layer and cutting the adhesive, be careful not to damage interior and exterior parts.

B: INSTALLATION

- 1) After cutting layer of adhesive, remove dam rubber remaining on body.
- 2) Finishing adhesion surface on body side: Using a cutter knife etc., cut layer of adhesive sticking firmly to body, and finish it to a smooth surface of about 2 mm (0.08 in) in thickness.

CAUTION:

Take extra care not to cause damage to body paint.

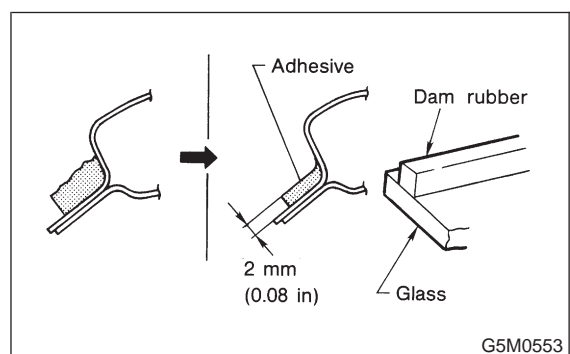

- 3) Cleaning body surface:
 - (1) Thoroughly remove chips, dirt and dust from body surface.
 - (2) Clean body wall surface and upper surface of layer of adhesive with a solvent such as alcohol or white gasoline.
- 4) Positioning glass:
 - (1) Mount glass on body.
 - (2) Adjust position of glass so that gap between body and glass is uniform on all sides.

- (3) Put matching pin on body and glass in several places.

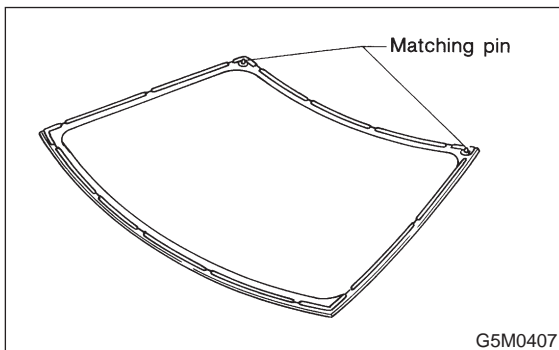

5) Cleaning glass:

- (1) Dismount glass from body
(2) Clean surface of glass to be adhered with alcohol or white gasoline.

6) Stick dam rubber and install front molding upper:

While aligning ceramic print notch (A) on windshield upper portion with mark (B) in center of upper front molding, install upper front molding on windshield.

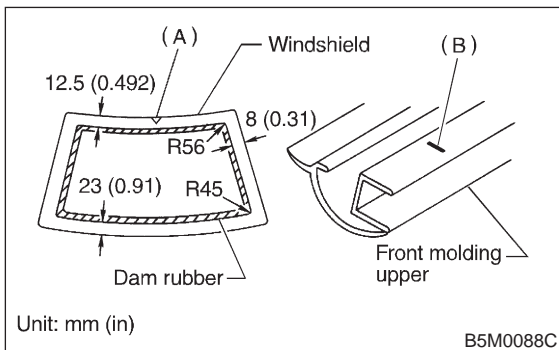

7) Application of primer:

- (1) Using a sponge, apply primer to part of glass to be adhered.

- (2) Apply primer to part of body to be adhered.

CAUTION:

- Primer is hard to wipe off of body paint, instrument panel, inner trim, etc. So put masking around these areas for protection.
- After application, let 1st primer dry spontaneously for about 10 minutes.
- Do not touch primer-coated surface under any circumstances.

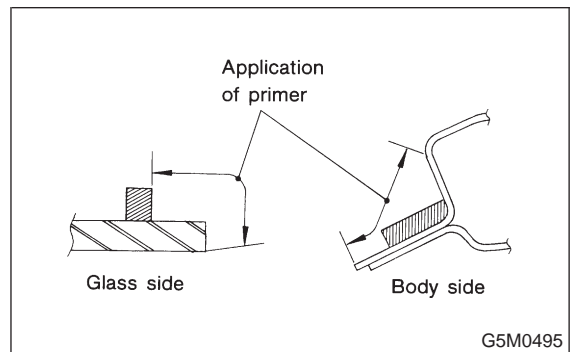

8) Application of adhesive:

- (1) Cut nozzle tip of cartridge as shown in figure.

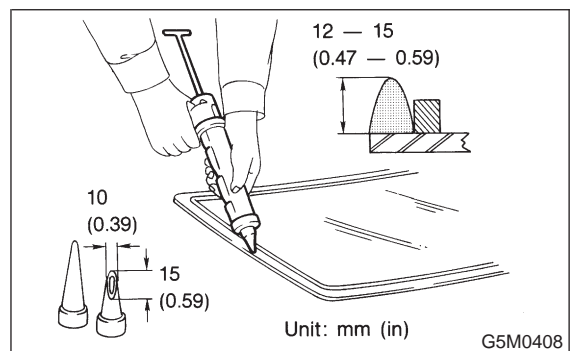

- (2) Open cartridge and put it into a gun with nozzle attached.
(3) Apply adhesive uniformly to all sides of adhesion surface while operating gun along glass end face.

9) Installation of glass:

- (1) Hold glass with rubber suction cups.
(2) Mount glass on body with matching pin aligned.

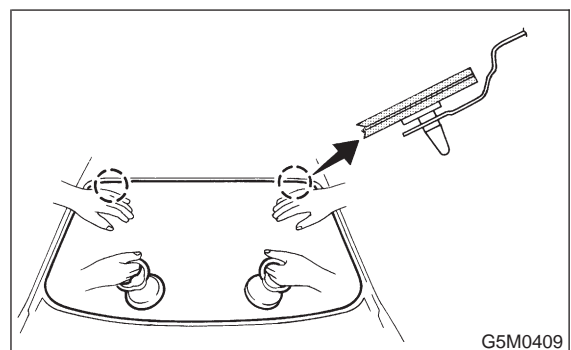

- (3) Stick them fast by pressing all sides lightly.
10) Installation of molding:
(1) Remove adhesive overflowing from outside of glass until it becomes level with outer height of glass. Then, add adhesive to portions that need it, and clean with alcohol or white gasoline.

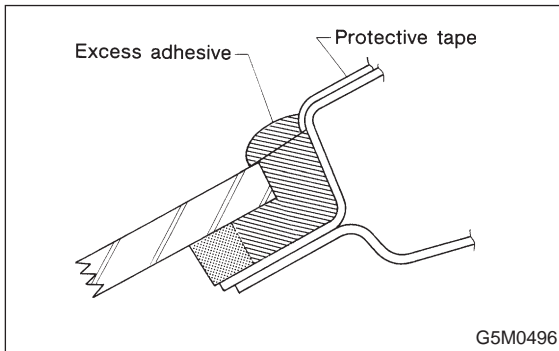

- (2) Install front side molding.

CAUTION:

Do not open and close door after moldings have been installed. When opening and closing door for unavoidable reason, lower door glass and gently move door.

- 11) Water leakage test:
Test for water leakage about one hour after installation.

CAUTION:

- Move vehicle very gently.
- Do not squirt strong hose stream on vehicle.

- 12) Spontaneous drying:
After completing all operations, leave vehicle alone for 24 hours.

CAUTION:

When delivering vehicle to user, tell him that vehicle should not be subjected to heavy shocks for at least three days.

- 13) Install cowl panel and wiper arm.

6. Rear Window Glass

A: REMOVAL

1. SEDAN

- 1) Disconnect connector from rear defogger terminal.
- 2) Remove glass in the same manner as in windshield.

NOTE:

A matching pin is cemented to the corners of glass on compartment side. Use a piano wire when cutting each pin.

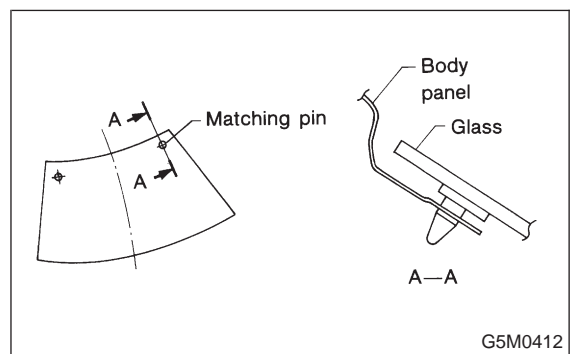

2. WAGON

NOTE:

It is impossible to remove the molding from the glass. If molding is broken, replace rear glass.

- 1) Remove rear wiper and rear gate trim.
- 2) Disconnect connector from rear defogger terminal.
- 3) Remove glass in the same manner as in windshield.

CAUTION:

In case of using a piano wire, when re-installing the old rear window glass, be careful not to damage molding.

NOTE:

A matching pin is cemented to corners of glass on compartment side. Use a piano wire when cutting each pin.

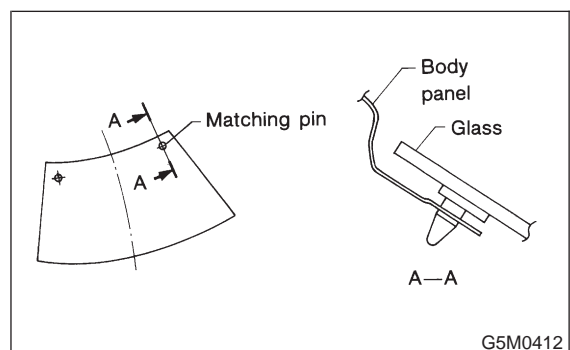

- (3) Stick them fast by pressing all sides lightly.
10) Installation of molding:
(1) Remove adhesive overflowing from outside of glass until it becomes level with outer height of glass. Then, add adhesive to portions that need it, and clean with alcohol or white gasoline.

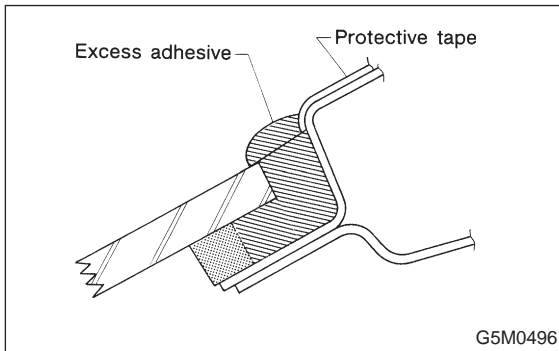

- (2) Install front side molding.

CAUTION:

Do not open and close door after moldings have been installed. When opening and closing door for unavoidable reason, lower door glass and gently move door.

- 11) Water leakage test:
Test for water leakage about one hour after installation.

CAUTION:

- Move vehicle very gently.
- Do not squirt strong hose stream on vehicle.

- 12) Spontaneous drying:
After completing all operations, leave vehicle alone for 24 hours.

CAUTION:

When delivering vehicle to user, tell him that vehicle should not be subjected to heavy shocks for at least three days.

- 13) Install cowl panel and wiper arm.

6. Rear Window Glass

A: REMOVAL

1. SEDAN

- 1) Disconnect connector from rear defogger terminal.
- 2) Remove glass in the same manner as in windshield.

NOTE:

A matching pin is cemented to the corners of glass on compartment side. Use a piano wire when cutting each pin.

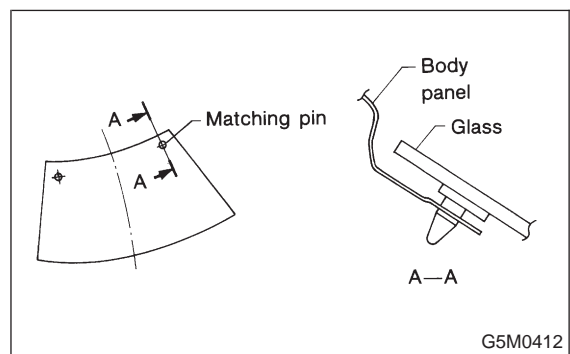

2. WAGON

NOTE:

It is impossible to remove the molding from the glass. If molding is broken, replace rear glass.

- 1) Remove rear wiper and rear gate trim.
- 2) Disconnect connector from rear defogger terminal.
- 3) Remove glass in the same manner as in windshield.

CAUTION:

In case of using a piano wire, when re-installing the old rear window glass, be careful not to damage molding.

NOTE:

A matching pin is cemented to corners of glass on compartment side. Use a piano wire when cutting each pin.

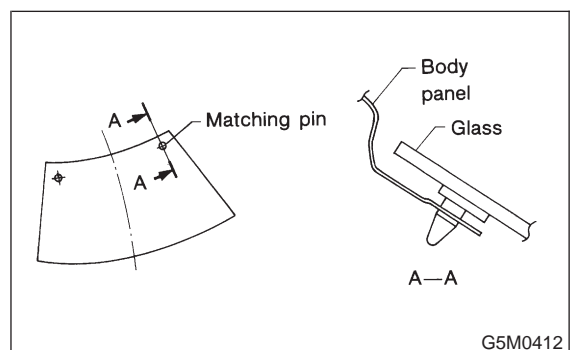

B: INSTALLATION

1. SEDAN

- 1) Install glass in the same manner as in windshield.
- 2) Stick dam rubber (A).
- 3) While aligning ceramic print notch (B) on rear window glass with marks in the center of upper and lower moldings, install the two moldings on rear window glass.

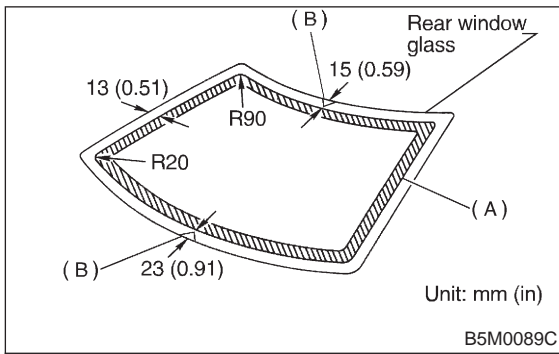

- 4) Make rear defogger connections.
- 5) After installation, test for water leakage after about one hour, and leave vehicle alone for 24 hours.

2. WAGON

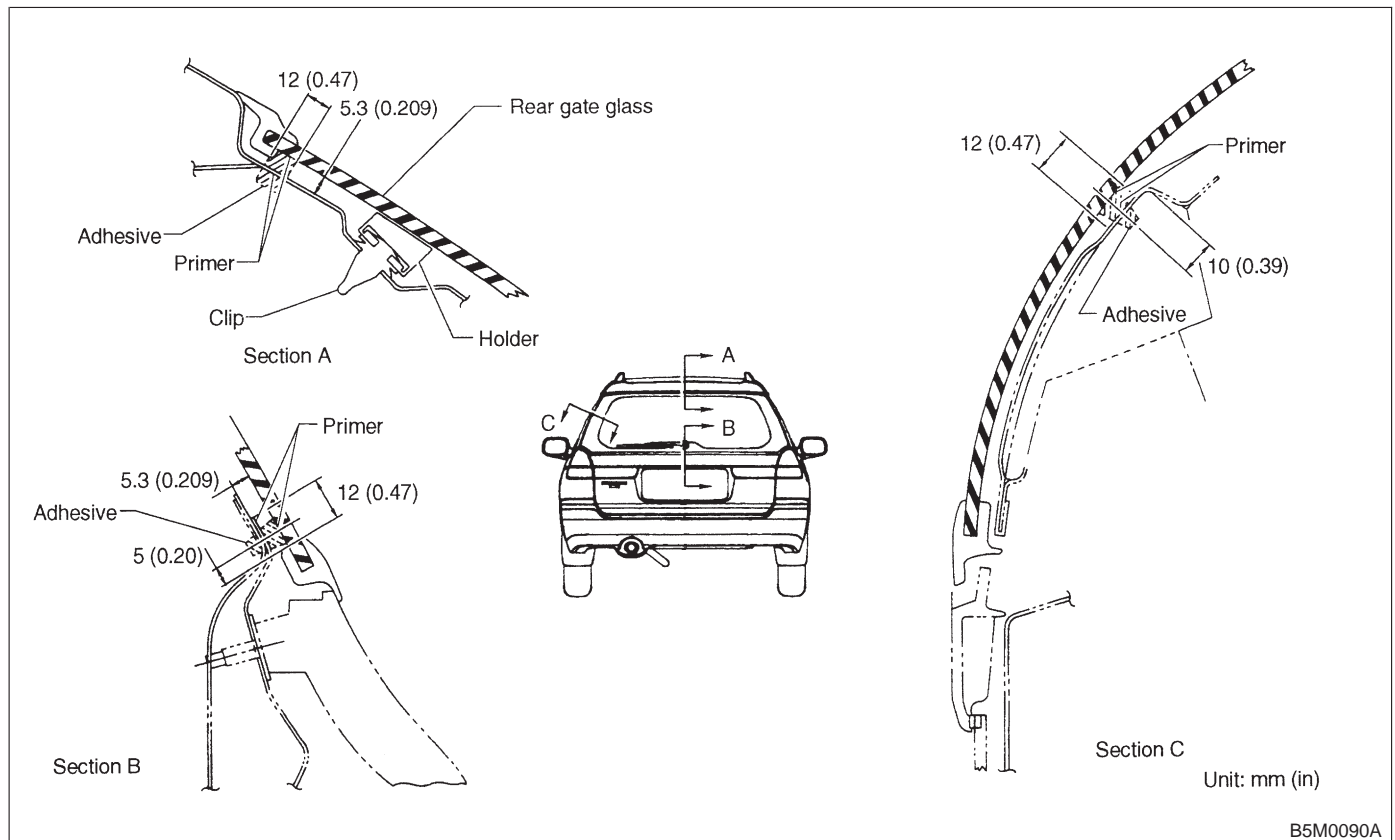

- 1) Install rear gate trim.
- 2) Install glass in the same manner as in windshield.
- 3) About one hour after installation, test for water leakage. Leave vehicle for 24 hours before using it.
- 4) Connect rear defogger connections.
- 5) Install high-mount stop light and rear wiper.

7. Rear Quarter Glass

A: REMOVAL

1. SEDAN

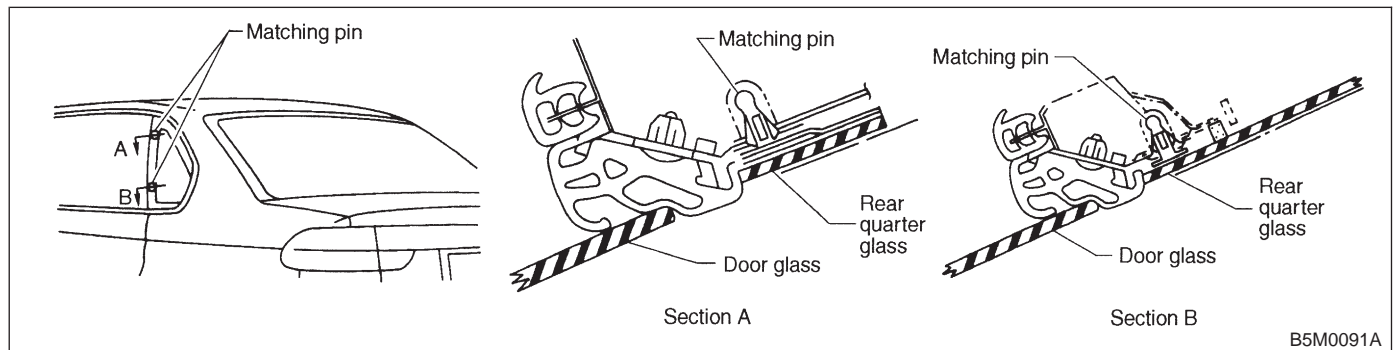

1) Remove rear quarter molding.

2) Remove glass in the same manner as in windshield.

2. WAGON

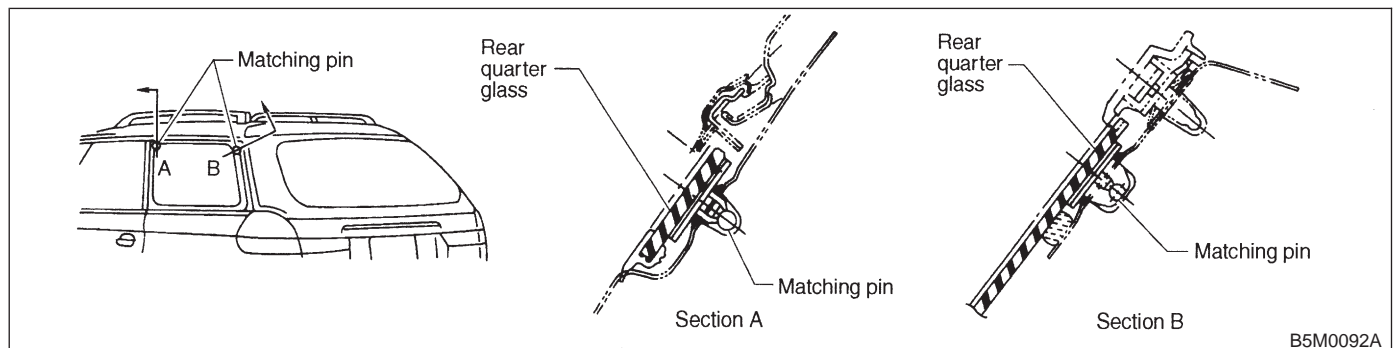

1) Remove rear quarter molding.

2) Remove glass in the same manner as in windshield.

B: INSTALLATION

1) Finish surface of adhesive layer on body. Using a putty knife, etc., cut layer of adhesive stick firmly to body and finish it into a smooth surface of about 2 mm (0.08 in) in thickness.

CAUTION:

Be careful not to damage body finish.

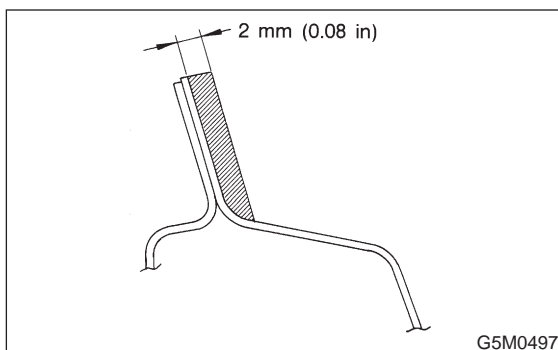

2) Cleaning of body surface:

(1) Remove chips, dirt and dust from body surface.

(2) Clean body wall surface and upper surface of adhesive layer with a solvent such as alcohol or white gasoline.

3) Cleaning glass:

(1) Remove dirt and dust from surface of glass to be adhered.

(2) Clean surface of glass to be adhered with alcohol or white gasoline.

4) Application of primer:

(1) Using a sponge, apply primer to surface of glass to be adhered.

5-2 [W7B0]

7. Rear Quarter Glass

SERVICE PROCEDURE

(2) Apply primer to surface of body to be adhered.

CAUTION:

- If primer has dropped on body finish, it is hard to wipe it off. So protect with masking.
- Primer must not project from black frame of glass.
- After applying primer, let it dry spontaneously for about 10 minutes.

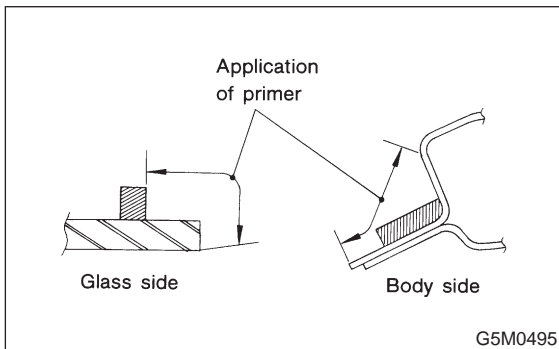

5) Application of adhesive:

(1) Cut nozzle tip as shown in figure.

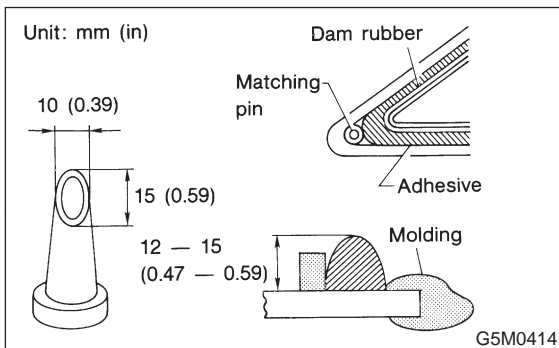

(2) Open cartridge and put it into a gun with nozzle attached.

(3) Apply adhesive uniformly to all sides of adhesion surface while operating gun along glass end face.

6) Installation of glass:

(1) Hold glass with rubber suction cups.

(2) Mount glass on body with matching pin aligned.

(3) Stick them fast by pressing all sides lightly.

7) Water leakage test:

After installing glass, test for water leakage after about one hour.

CAUTION:

- Move vehicle slowly.
- When opening and closing door, lower door glass and move door gently.
- Do not squirt strong hose stream on vehicle.

8) Spontaneous drying:

After completing all operations, leave vehicle alone for 24 hours.

CAUTION:

When delivering vehicle to user, tell him or her that vehicle should not be subjected to heavy shocks for at least three days.

1. Door Glass

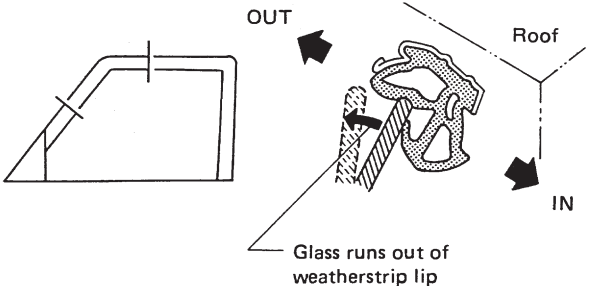
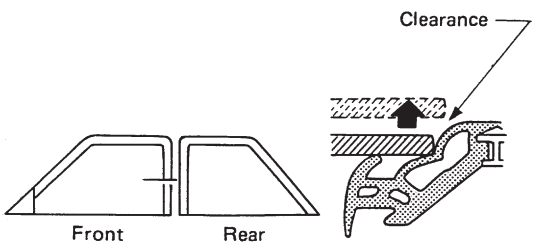
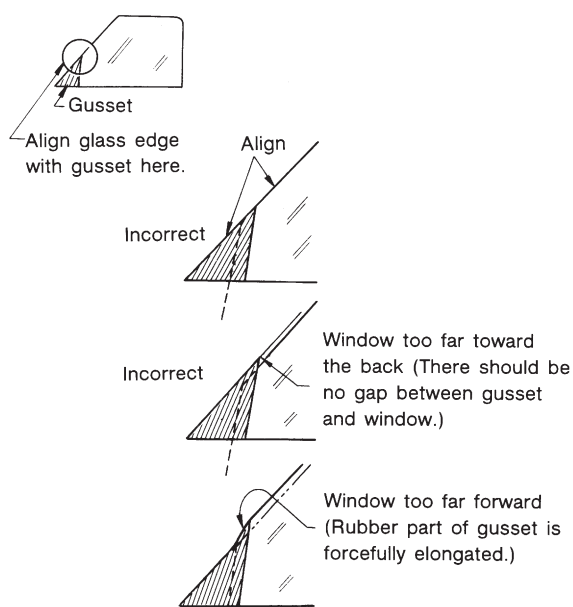
	Condition	Apparent cause/Correction
<p>Glass in fully closed position</p>	<p>1) Glass runs out of weatherstrip lip when considerable hand pressure is applied to it from inside.</p>  <p>G5M0502</p> <p>(This condition may cause wind/booming noise during high-speed operation.)</p>	<ul style="list-style-type: none"> ● Insufficient upward travel of glass Increase upward travel of glass.
	<p>2) Clearance exists between glass and weatherstrip when light hand pressure is applied to it at center and rear pillar locations.</p>  <p>G5M0503</p> <p>(This condition may cause wind noise and/or water leakage.)</p>	<ul style="list-style-type: none"> ● Insufficient glass-to-door weatherstrip contact Check stabilizer and glass for proper contact. Increase contact using upper sash adjustment bolt. ● Improper adjustment of striker in in-out direction Close door and check for alignment of striker with vehicle body.
	<p>3) Adjust door glass so that it is aligned with door rearview mirror gusset.</p>  <p>G5M0504</p>	<ul style="list-style-type: none"> ● Window is not properly adjusted in up-down/fore-aft direction. Adjust window. If necessary, move B channel regulator to eliminate window tilt. ● Gusset is not properly adjusted in fore-aft direction. Adjust gusset after loosening all bolts and nuts with tightening it.

DIAGNOSTICS

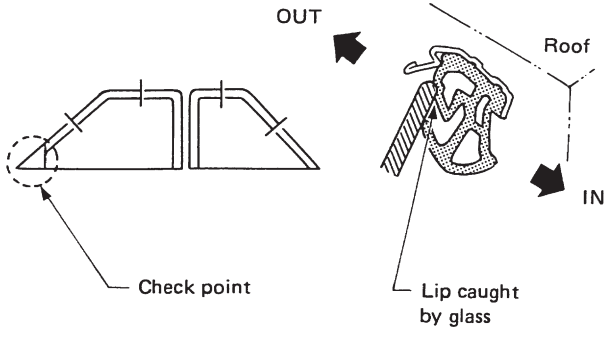
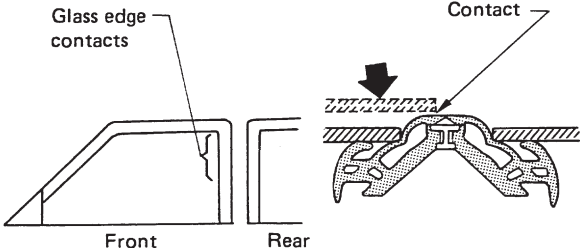
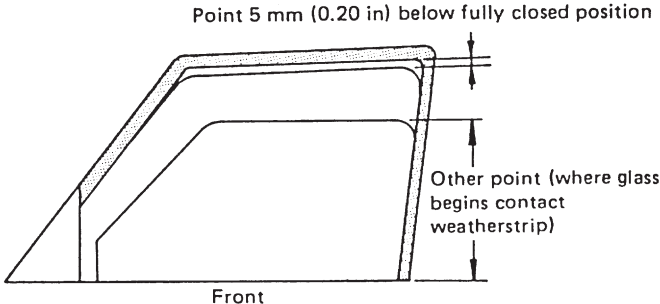
	Condition	Apparent cause/Correction
<p>Door in fully closed/ open position</p>	<p>1) Glass rides over weatherstrip lip when door is closed.</p>  <p style="text-align: right;">G5M0505</p> <p>(This condition increases wind/booming noise, leakage and/or effort required to close door.)</p>	<ul style="list-style-type: none"> ● Improper up-down and in-out glass alignments <p>Adjust glass for up-down and in-out alignments (incl. rear sash, upper stopper adjustment, etc.). If necessary, correct glass tilt by moving B channel regulator.</p>
	<p>2) Edge of glass contacts retainer when door is fully closed.</p>  <p style="text-align: right;">G5M0506</p>	<ul style="list-style-type: none"> ● Improper glass-to-center pillar weatherstrip or excessive glass contact to weatherstrip ● Excessive adjusting in contact to weatherstrip <p>Causes rear edge of glass to tilt inboard closer to center pillar. Adjust rear sash adjustment bolt to reduce glass contact to weatherstrip.</p>
<p>Raise or lower window glass</p>	<p>1) Considerable effort or time is required to operate regulator. Standard operating effort:</p> <ul style="list-style-type: none"> ● Entire up-down travel except for point 5 mm (0.20 in) below fully closed position: 29.4 N (3.0 kg, 6.6 lb) ● Point 5 mm (0.20 in) below fully closed position: 44.1 N (4.5 kg, 9.9 lb)  <p style="text-align: right;">G5M0507</p>	<ul style="list-style-type: none"> ● Sliding resistance increased due to high stabilizer-to-glass contact pressure. ● High glass-to-windshield contact pressure <p>Reduce contact by mounting inner stabilizer to inside of the vehicle. Reduce contact using upper sash adjustment bolt.</p> <ul style="list-style-type: none"> ● Unequal contact adjustment stroke between front and rear sashes Set to equal stroke. ● Tilt of rear sash adjustment bolt mounting bracket <p>Correct tilt of bracket so it is parallel to inner panel.</p>

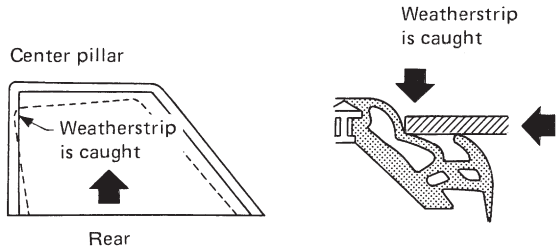
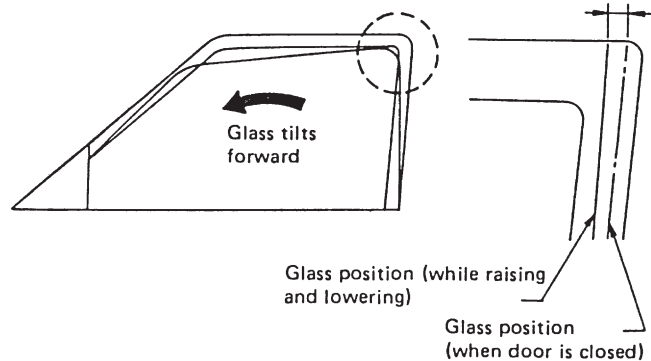
	Condition	Apparent cause/Correction
<p>Raise or lower window glass</p>	<p>2) Center pillar weatherstrip is caught by rear window glass when glass is raised.</p>  <p style="text-align: right;">G5M0508</p>	<ul style="list-style-type: none"> ● Improper fore-aft or in-out alignment of window glass <p>Lower B channel regulator to tilt window glass back.</p>
	<p>3) Window glass tilts forward by more than 2 mm (0.08 in).</p>  <p style="text-align: right;">G5M0509</p> <p>Excessive tilt of glass forward is due to excessive glass "contact" which causes reaction of center pillar weatherstrip. Glass can be tilted forward due to increase in reaction of shoulder weatherstrip or free play between sash and roller. Taking these symptoms into account, glass should be aligned.</p>	<ul style="list-style-type: none"> ● Excessive glass contact pressure or improper in-out alignment <p>(1) Lower B channel regulator to tilt window glass rearward. (2) Reduce contact pressure using upper sash adjustment bolt.</p>

MEMO:

1. Front Seat

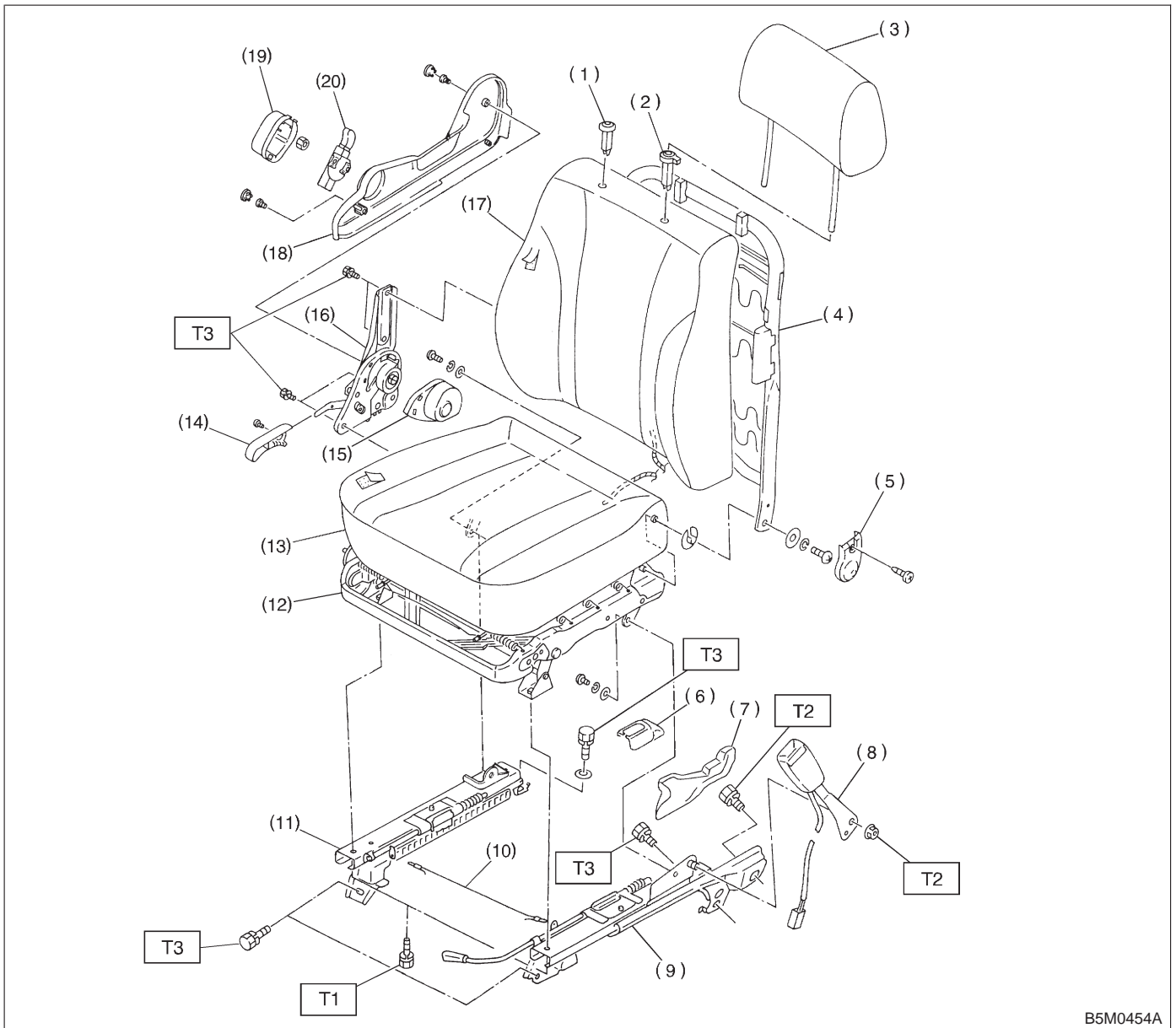

B5M0454A

- | | | |
|-------------------------------|-------------------------------|-----------------------|
| (1) Headrest free bushing | (10) Connect wire | (19) Tilt lever cover |
| (2) Headrest lock bushing | (11) Outer slide rail ASSY | (20) Tilt lever ASSY |
| (3) Headrest ASSY | (12) Front cushion frame ASSY | |
| (4) Front backrest frame ASSY | (13) Cushion ASSY | |
| (5) Protector | (14) Reclining lever | |
| (6) Cover (Bolt) (outer) | (15) Hinge spring cover | |
| (7) Cover (Bolt) (inner) | (16) Reclining hinge ASSY | |
| (8) Inner belt ASSY | (17) Backrest ASSY | |
| (9) Inner slide rail ASSY | (18) Hinge cover | |

Tightening torque: N-m (kg-m, ft-lb)

T1: 23±5 (2.3±0.5, 16.6±3.6)

T2: 29±7 (3.0±0.7, 21.7±5.1)

T3: 52±10 (5.3±1.0, 38±7)

2. Rear Seat

A: SEDAN

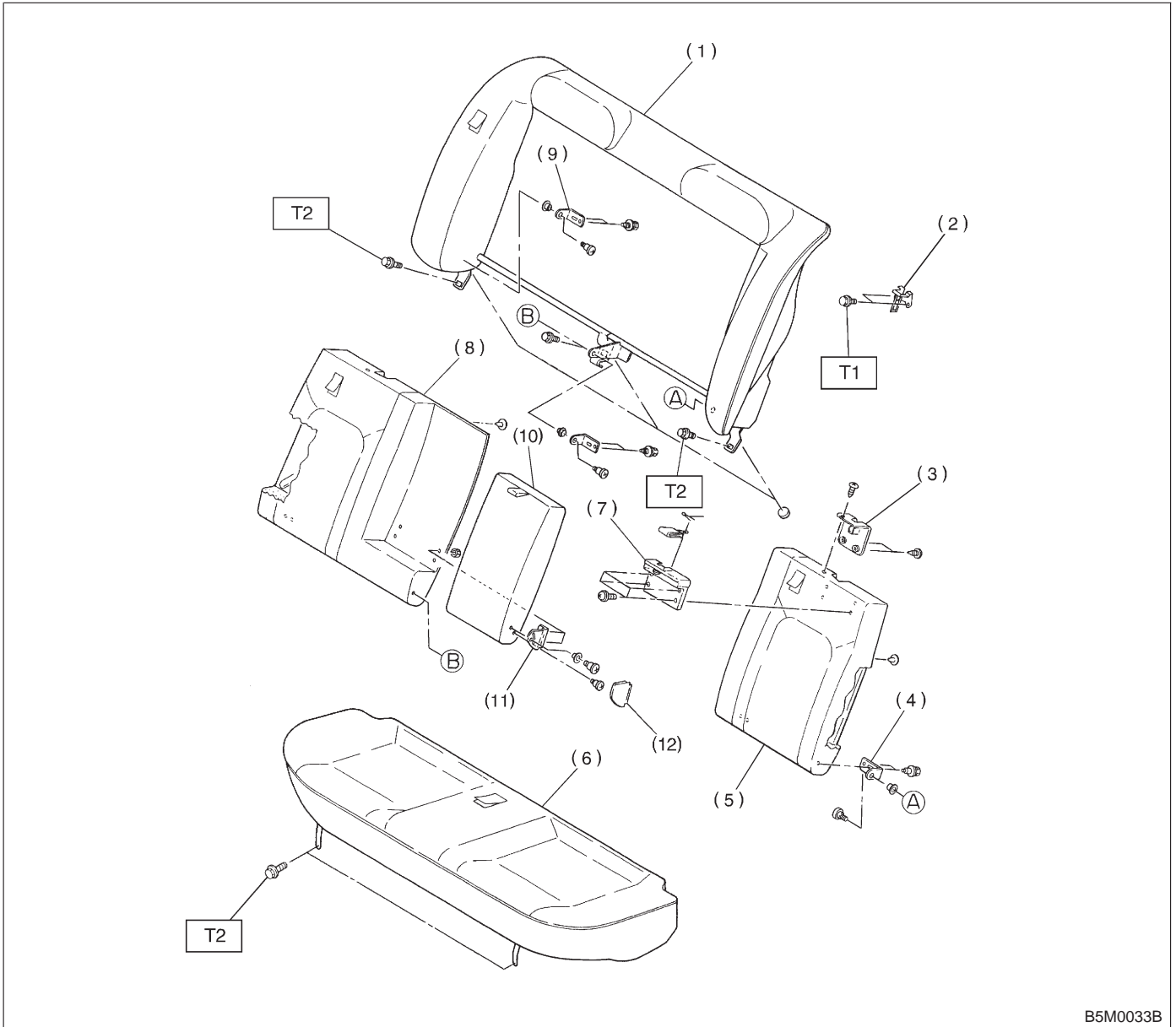

B5M0033B

- | | |
|-------------------|-------------------|
| (1) Backrest | (7) Lock ASSY |
| (2) Striker | (8) Backrest (RH) |
| (3) Lock cover | (9) Bracket (RH) |
| (4) Bracket (LH) | (10) Arm rest |
| (5) Backrest (LH) | (11) Hinge |
| (6) Cushion | (12) Cover |

Tightening torque: N-m (kg-m, ft-lb)

T1: 10±3 (1.0±0.3, 7.2±2.2)

T2: 25±7 (2.5±0.7, 18.1±5.1)

B: WAGON

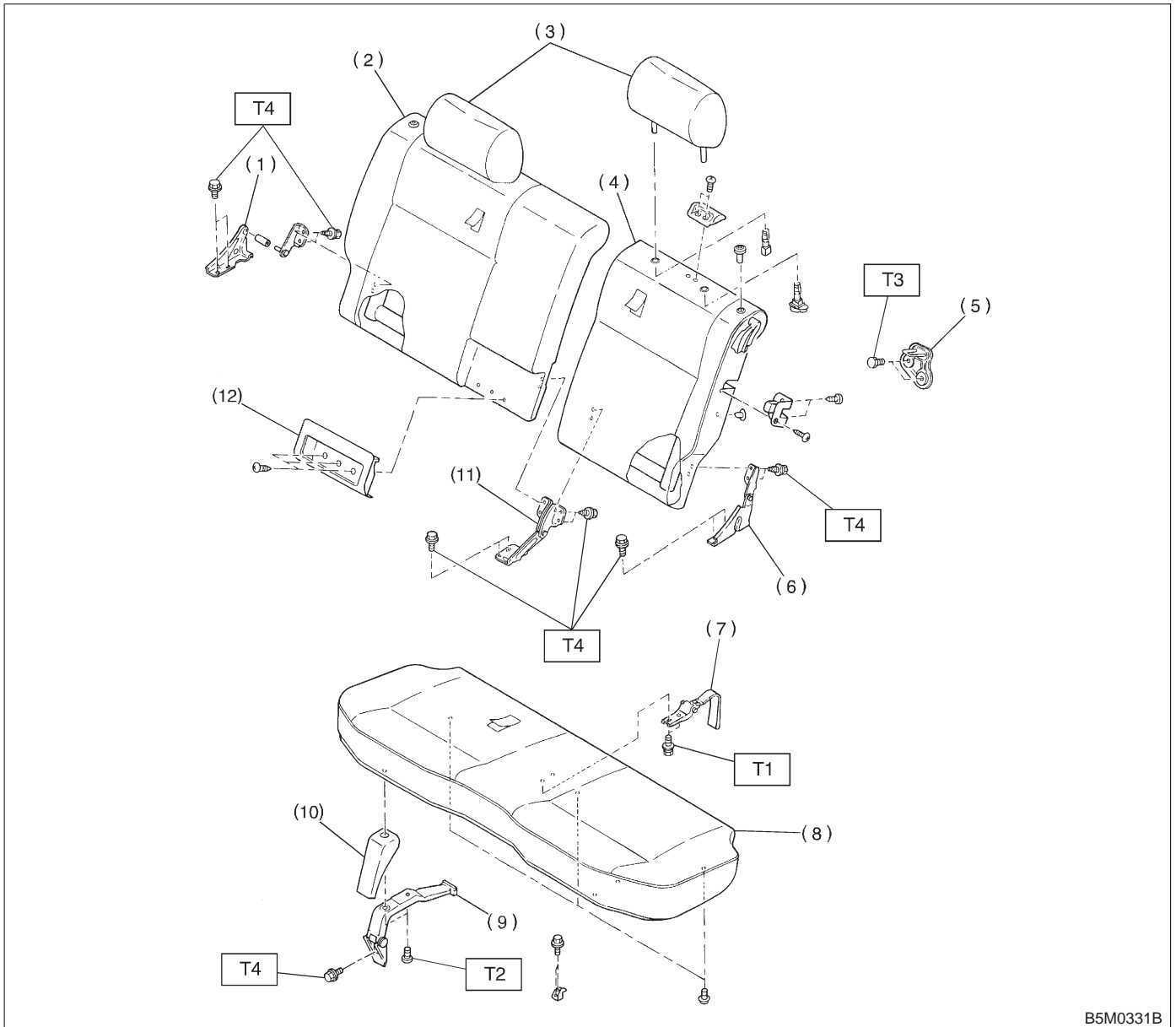

B5M0331B

- | | |
|------------------------|----------------------------|
| (1) Hinge bracket (RH) | (8) Rear cushion |
| (2) Backrest (RH) | (9) Hinge |
| (3) Pillow | (10) Hinge cover |
| (4) Backrest (LH) | (11) Backrest center hinge |
| (5) Striker | (12) Pocket |
| (6) Hinge bracket (LH) | |
| (7) Lock hinge | |

Tightening torque: N-m (kg-m, ft-lb)

T1: 2±1 (0.2±0.1, 1.4±0.7)

T2: 5.9±1.5 (0.6±0.15, 4.3±1.1)

T3: 10±3 (1.0±0.3, 7.2±2.2)

T4: 25±7 (2.5±0.7, 18.1±5.1)

3. Front Seat Belt

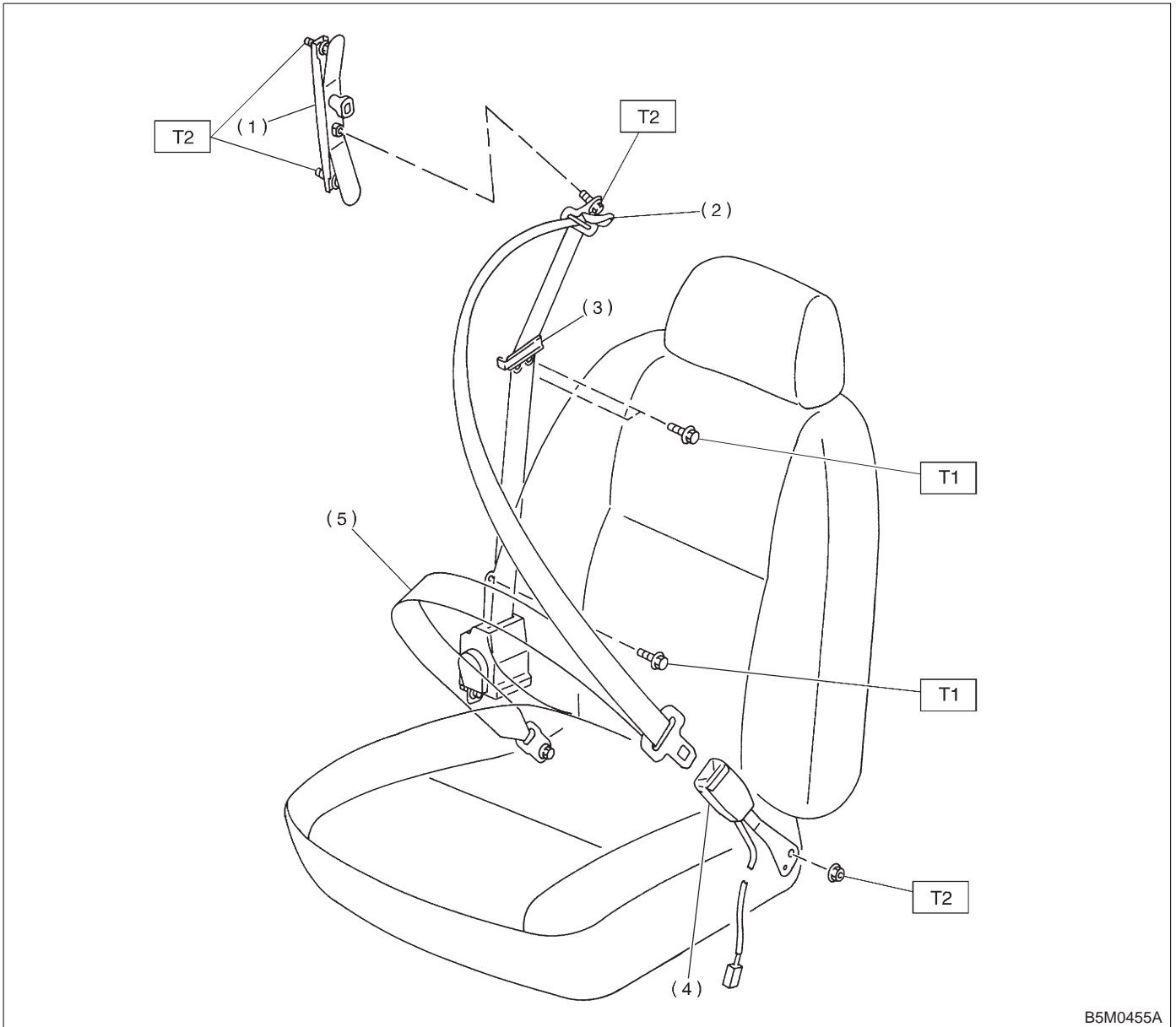

B5M0455A

- (1) Adjuster anchor ASSY
- (2) Through anchor cover
- (3) Webbing guide
- (4) Inner belt ASSY

- (5) Outer belt ASSY

Tightening torque: N-m (kg-m, ft-lb)

T1: 13±3 (1.3±0.3, 9.4±2.2)

T2: 35±13 (3.6±1.3, 26±9)

4. Rear Seat Belt

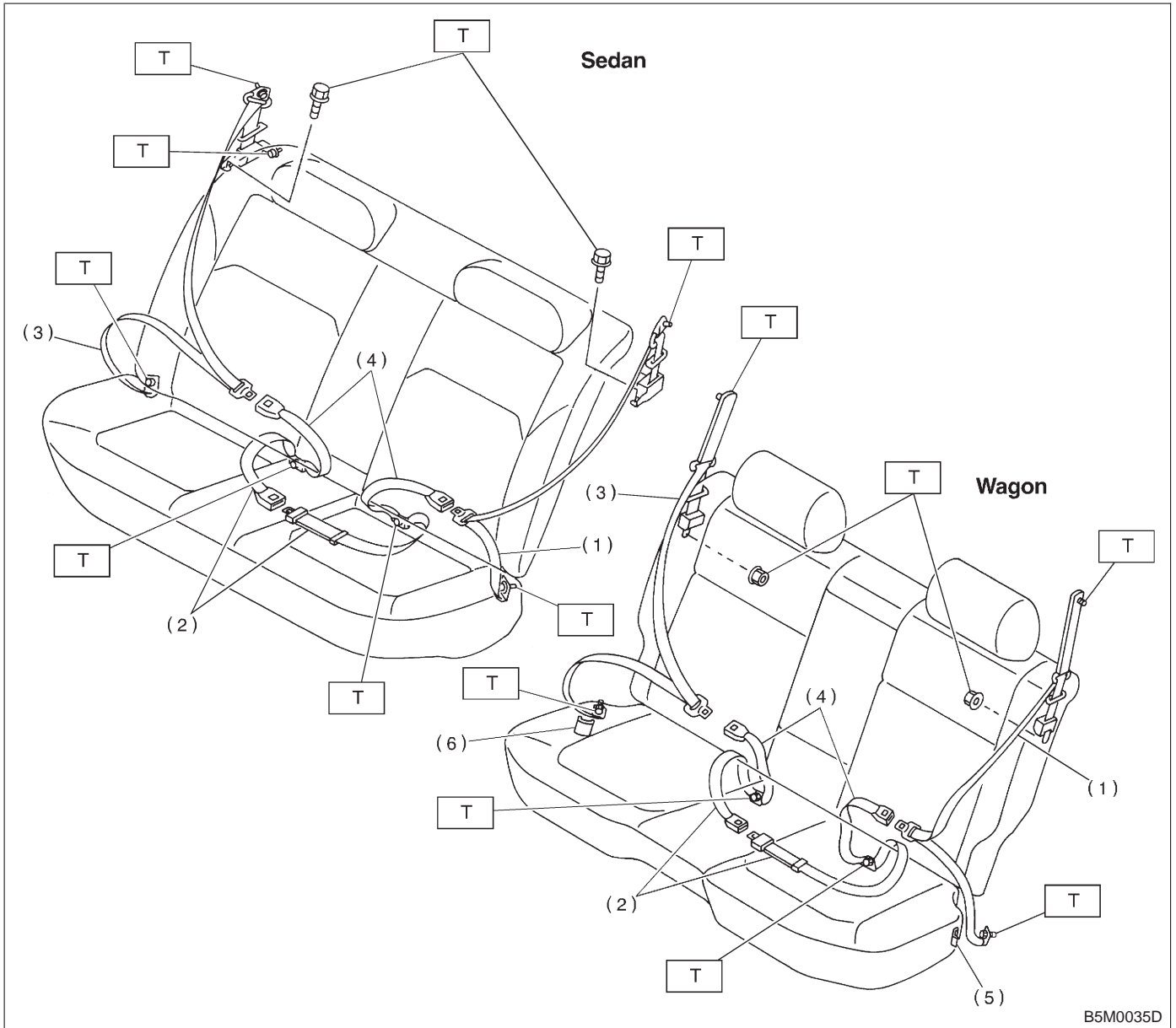

- (1) Outer seat belt (LH)
- (2) Center seat belt
- (3) Outer seat belt (RH)
- (4) Inner seat belt
- (5) Lap anchor cover (LH)
- (6) Lap anchor cover (RH)

Tightening torque: N-m (kg-m, ft-lb)
T: 35±13 (3.6±1.3, 26±9)

5. Inner Trim

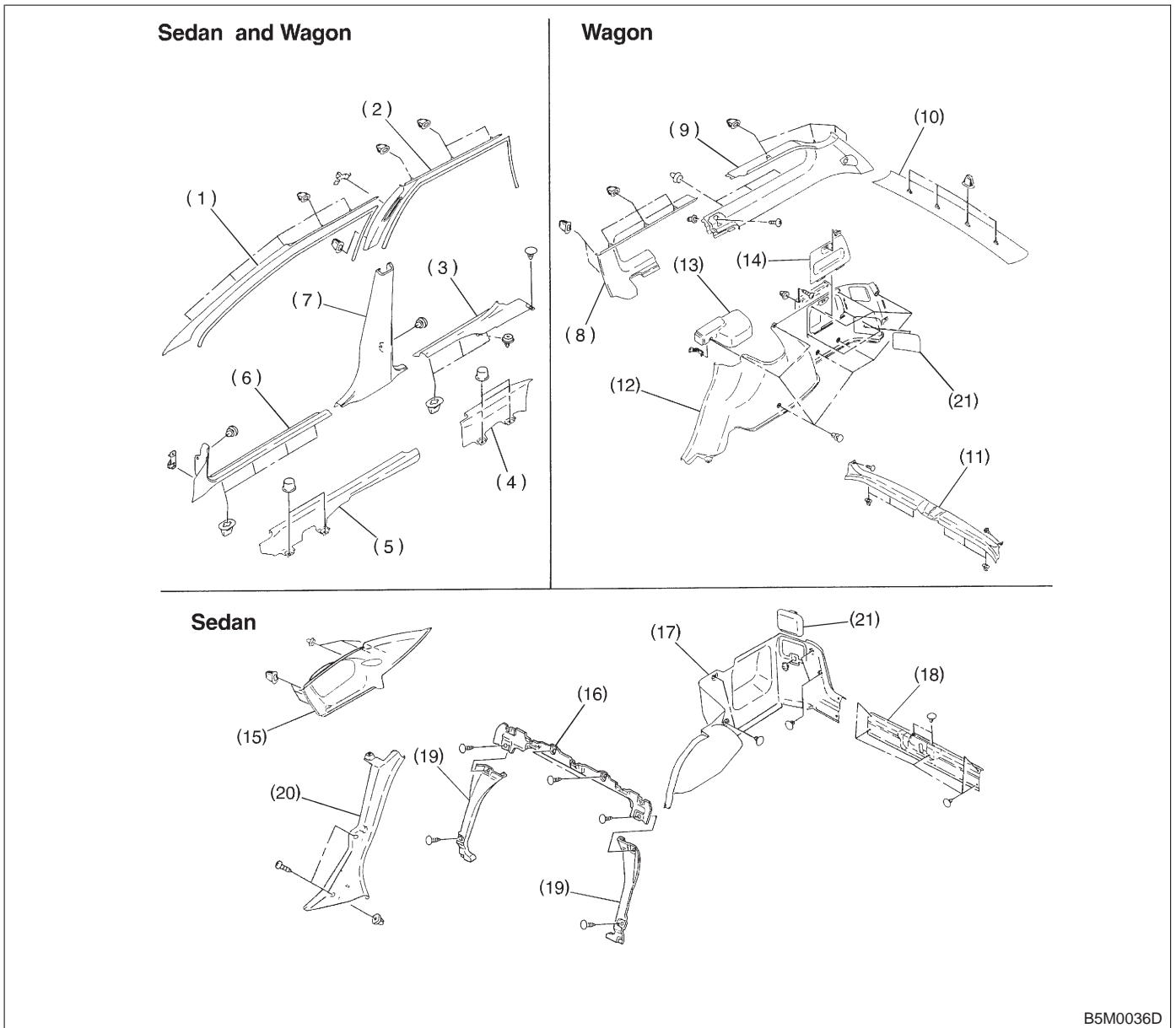

B5M0036D

- | | | |
|---------------------------------|-------------------------------------|-----------------------------|
| (1) Front pillar upper trim | (8) Rear quarter upper front trim | (15) Rear pillar upper |
| (2) Center pillar upper trim | (9) Rear quarter upper rear trim | (16) Rear upper bulk |
| (3) Side sill rear upper cover | (10) Rear rail trim | (17) Trunk side trim |
| (4) Side sill rear lower cover | (11) Edge rear trim | (18) Trunk rear trim |
| (5) Side sill front lower cover | (12) Rear quarter pillar lower trim | (19) Rear side bulk trim |
| (6) Front pillar lower trim | (13) Cap strut | (20) Rear pillar lower trim |
| (7) Center pillar lower trim | (14) Lid pocket | (21) Lamp cover |

1. Front Seat

A: REMOVAL

1) While operating knob (located on top of backrest), lift headrest out with hand placed between backrest and headrest.

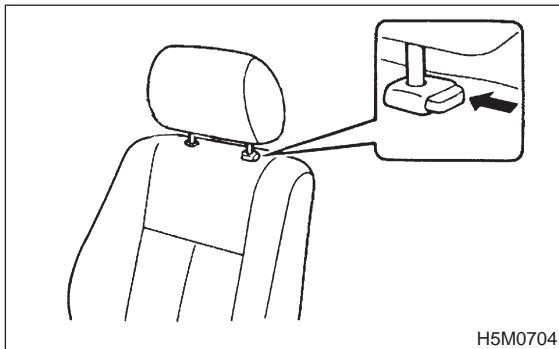

2) Pull reclining lever back to fold backrest all the way forward. While pulling slide adjuster lever, move seat all the way forward.

3) Disconnect connector under driver's seat.

4) Disconnect side airbag connector. (Side airbag equipped vehicle) <Ref. to 5-5 [M2F2].>

5) Remove bolt cover at rear end of slide rail.

6) Remove bolts securing seat rear.

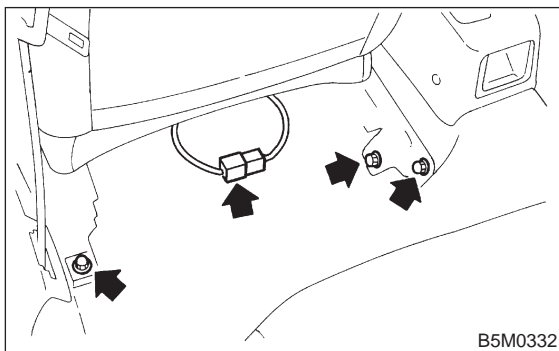

7) While pulling slide adjuster lever, slide seat all the way back.

8) Remove bolts securing front of seat.

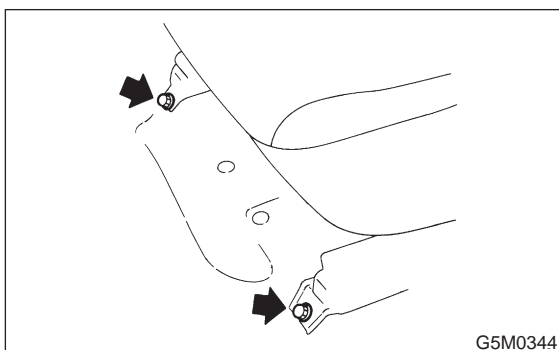

9) Remove front seat from vehicle, then install headrest.

CAUTION:

- Be careful not to scratch seat when removing it from vehicle.

- After the front seat has been removed from side airbag equipped vehicle, store it as instructed in section 5-5 AIRBAG REPAIR SECTION. <Ref. to 5-5 [W3A0].>

B: INSTALLATION

1) While operating knob (located on top of backrest), lift headrest out with hand placed between backrest and headrest.

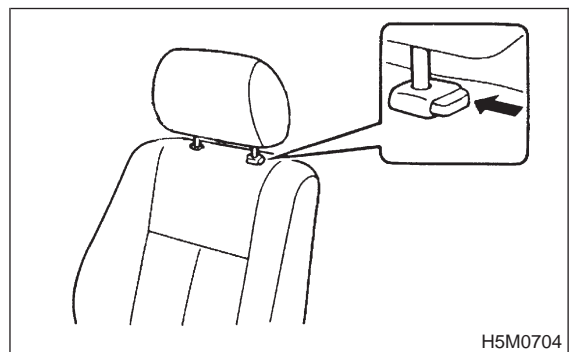

2) Pull reclining lever back to fold backrest all the way forward. Pull slide adjuster lever and move lower slide rail all the way backward.

3) Position seat in compartment and align the holes on the seat with the holes on the vehicle body side.

4) Secure the front of seat using inward and outward bolts (A) and (B) in that order.

5) While pulling slide adjuster lever, move seat all the way forward.

6) Secure the rear of seat using inward and outward bolts (C) and (D) in that order.

7) Install bolt (E).

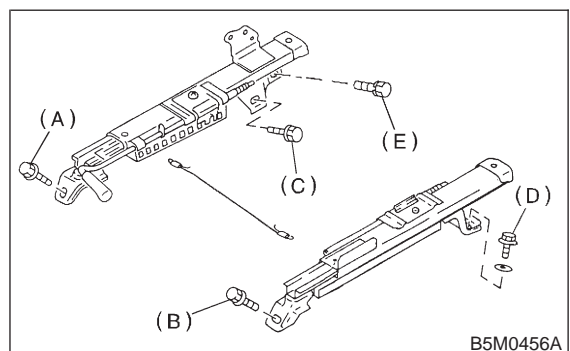

8) Connect connector under driver's seat.

9) Connect side airbag connector. (Side airbag equipped model)

CAUTION:

Check that all lock plate pawls are completely and equally inserted into the holes in the slide rail brackets.

10) After installation, ensure that all mechanisms operate properly and lock.

11) If any mechanism does not function properly, loosen bolts (C), (D) and (E), slide seat as required, insert all lock plate pawls into holes in slide rail brackets, and tighten bolts (C), (D) and (E) in that order.

12) Install bolt cover on rear end of slide rail.

13) Install headrest on backrest.

NOTE:

Tighten bolts in the designated order.

2. Rear Seat

A: REMOVAL

1. SEDAN

1) Remove bolts securing hinges (located at front of cushion) to body.

2) Slightly raise front of cushion while pushing down on cushion in the direction of "C". With cushion held in that position, move it forward until it is unhooked.

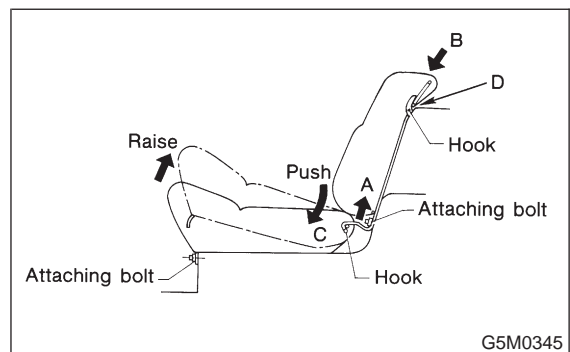

3) Remove bolts securing lower portion of backrest to body.

4) Pull strap (located in center of fold-down backrest) to release lock, and fold backrest onto cushion. (Fold-down type)

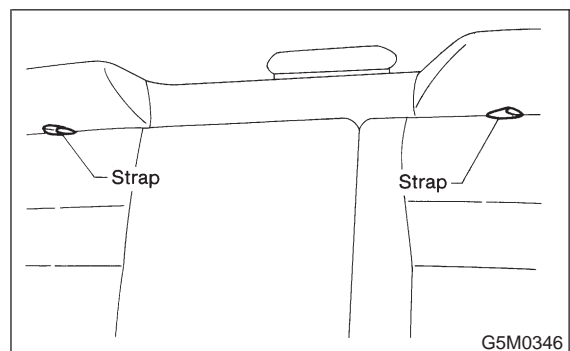

5) Lift rear seat backrest in direction "A" until it is released

10) After installation, ensure that all mechanisms operate properly and lock.

11) If any mechanism does not function properly, loosen bolts (C), (D) and (E), slide seat as required, insert all lock plate pawls into holes in slide rail brackets, and tighten bolts (C), (D) and (E) in that order.

12) Install bolt cover on rear end of slide rail.

13) Install headrest on backrest.

NOTE:

Tighten bolts in the designated order.

2. Rear Seat

A: REMOVAL

1. SEDAN

1) Remove bolts securing hinges (located at front of cushion) to body.

2) Slightly raise front of cushion while pushing down on cushion in the direction of "C". With cushion held in that position, move it forward until it is unhooked.

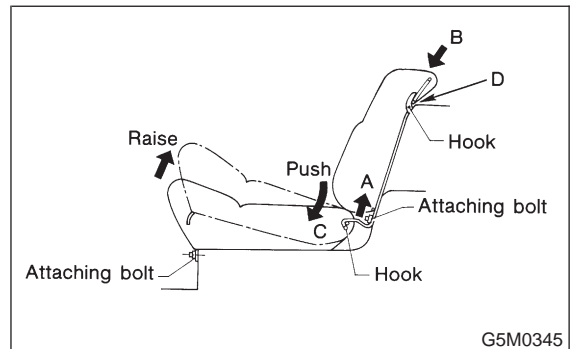

3) Remove bolts securing lower portion of backrest to body.

4) Pull strap (located in center of fold-down backrest) to release lock, and fold backrest onto cushion. (Fold-down type)

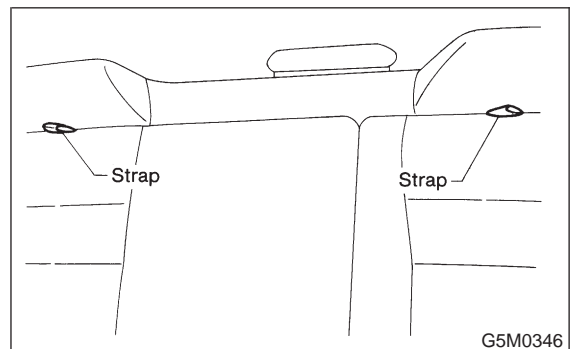

5) Lift rear seat backrest in direction "A" until it is released

2. WAGON

1) Remove bolts securing hinges (located at front of seat) to body.

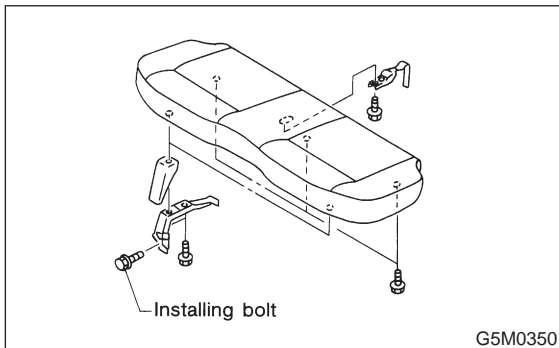

2) Pull strap (located in middle rear portion of cushion) to release lock. Lift cushion out and away from body.

3) Pull knobs (located at each side of backrest's upper portion) up to release lock, and fold backrest all the way forward.

4) Remove the bolt (A) and then remove backrest. (LH side)

5) Remove the bolt (B) and then remove backrest (RH side) from hinge bracket (C).

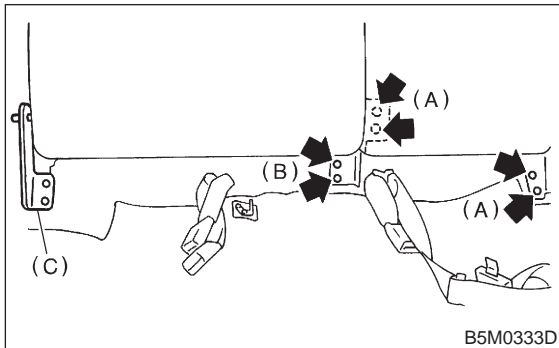

B: INSTALLATION

1. SEDAN

1) Before installing backrest, ensure that trim panel, insulator and seat belt are properly installed.

2) Transfer outer seat belt webbing to front of backrest and fold backrest forward. Attach seat wire to upper hooks (2 places), and move pillow in the direction of "B" until backrest is aligned with lower mounting holes in body.

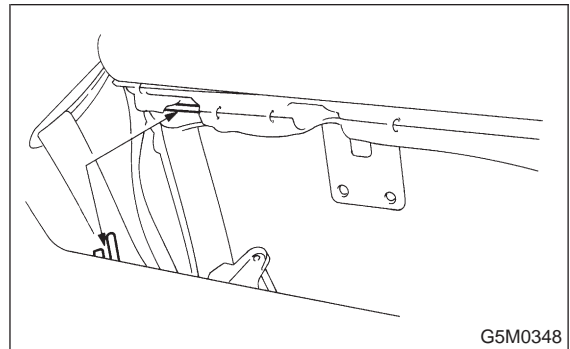

3) Engage backrest's folding mechanism with striker.

4) Secure lower center and both sides of backrest to body with bolts.

5) Slightly raise front section of cushion while pushing down on cushion in the direction of "C". With cushion held in that position, attach rear section of cushion to hooks at lower frame location.

CAUTION:

- Before installing seat, ensure that seat belt is placed on cushion.
- Confirm that winding of three-point type seat belt can operate regularly.

6) Secure front of cushion to body with bolts.

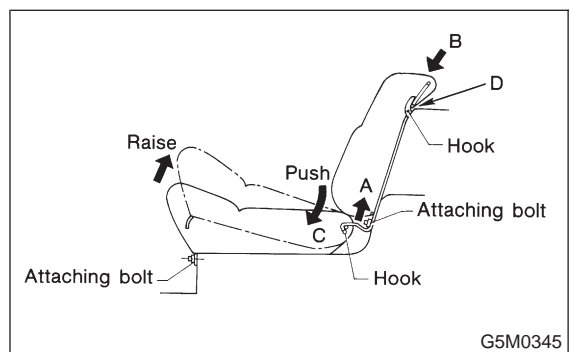

2. WAGON

Installation is in the reverse order of removal.

CAUTION:

- Do not allow center seat belt to get under cushion when folding cushion.
- Ensure that side seat belt tongue is free from cushion and trim panel.
- Lift front of cushion to ensure that cushion is properly locked.

3. Front Seat Belt

A: REMOVAL AND INSTALLATION

1. OUTER BELT

- 1) Remove through anchor cover cap.
- 2) Remove shoulder anchor bolt.

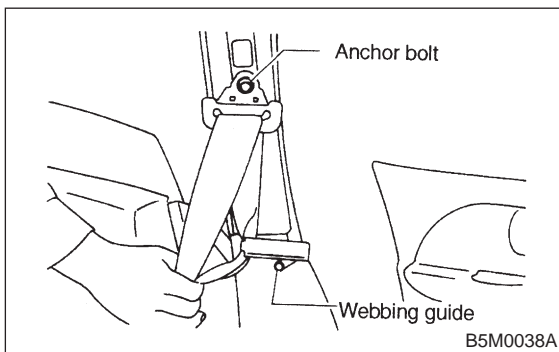

- 3) Remove side sill rear upper cover and front pillar lower trim.
- 4) Remove center pillar lower trim.
- 5) Remove webbing guide.
- 6) Roll up floor mat at the bottom of center pillar.
- 7) Remove lap anchor bolt.
- 8) Remove outer belt assembly.
- 9) Installation is in the reverse order of removal.

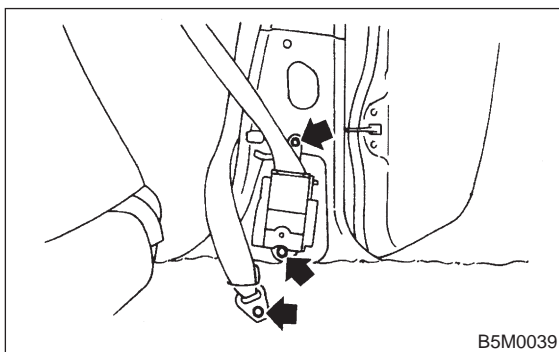

2. INNER BELT

- 1) Remove anchor nut.
- 2) Installation is in the reverse order of removal.

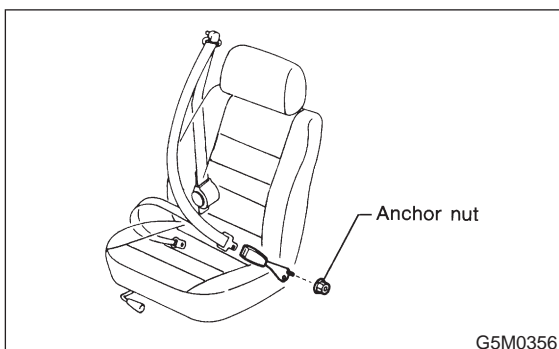

3. ADJUSTABLE SHOULDER ANCHOR

- 1) Remove shoulder anchor bolt.
- 2) Remove lower center pillar trim.
- 3) Remove front and center pillar upper trim.
- 4) Remove adjustable shoulder anchor assembly.

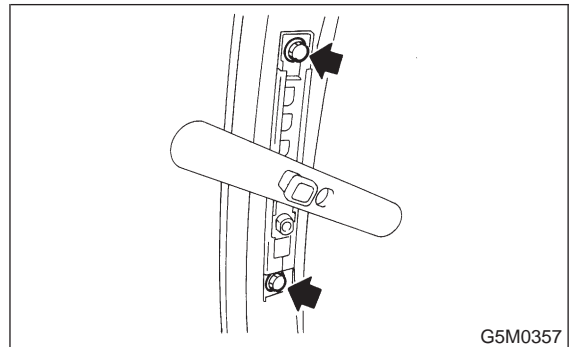

- 5) Installation is in the reverse order of removal.

CAUTION:

- The left and right ELR's are not mutually interchangeable because different sensors are used.
- Be careful not to twist belts during installation.

4. Rear Seat Belt

A: REMOVAL AND INSTALLATION

1. SEDAN

- 1) Remove rear cushion from vehicle.
- 2) Remove rear backrest from vehicle.
- 3) Remove rear pillar upper trim.
- 4) Remove outer anchor bolts.

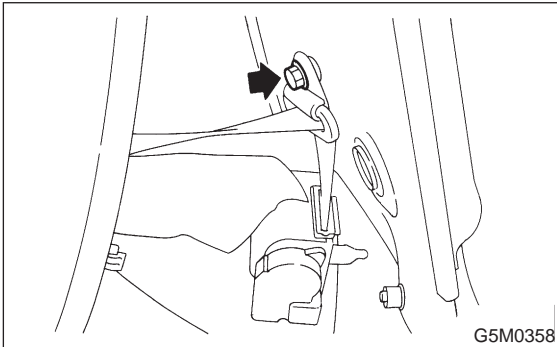

- 5) Remove ELR.

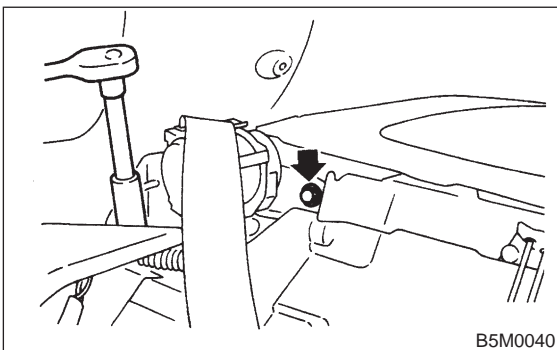

- 6) Remove anchor bolt of outer belt and then remove outer belt assembly.
- 7) Remove inner belt.

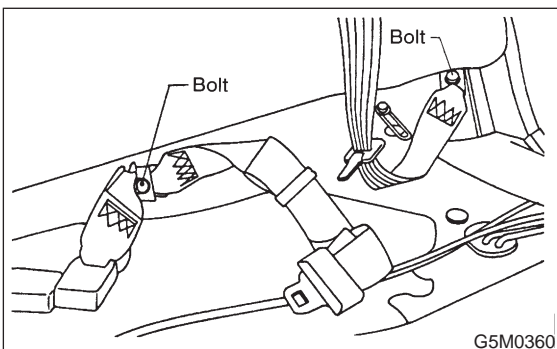

- 8) Installation is in the reverse order of removal.

2. WAGON

- 1) Raise rear cushion.

- 2) Remove shoulder anchor bolt.

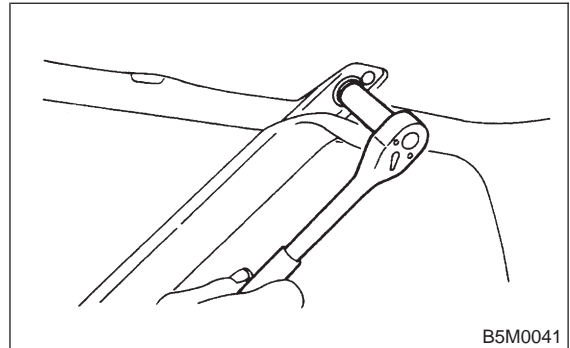

- 3) Remove cap strut.
- 4) Remove rear quarter upper front trim.
- 5) Remove ELR assembly.

CAUTION:

Remove outer seat belt and center seat belt in similar manner used to remove those from Sedan.

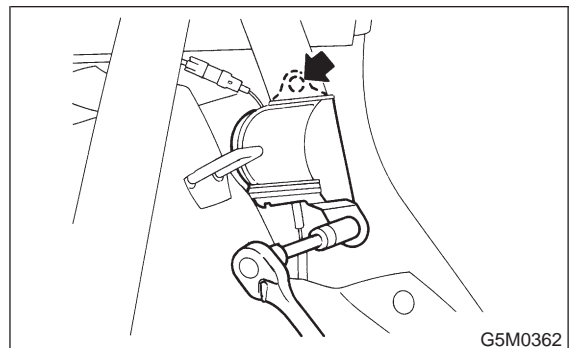

- 6) Remove lap anchor cover and then remove lower anchor bolt.

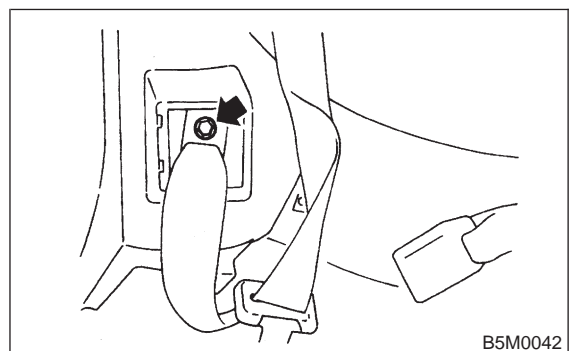

- 7) Remove outer belt assembly.
- 8) Installation is in the reverse order of removal. Ensure that seat belt is properly reeled on and off after installation of ELR.

CAUTION:

- Be extremely careful not to confuse center seat anchor plate with outer seat anchor plate during installation.
- Ensure that seat belts are free from twisting after installation.

- Ensure that tongues, buckles and belts are properly placed on seat.

5. Inner Trim Panel

A: REMOVAL AND INSTALLATION

1. SIDE SILL COVER

- 1) Remove front pillar lower trim (A).
- 2) Remove side sill rear upper cover trim (B).

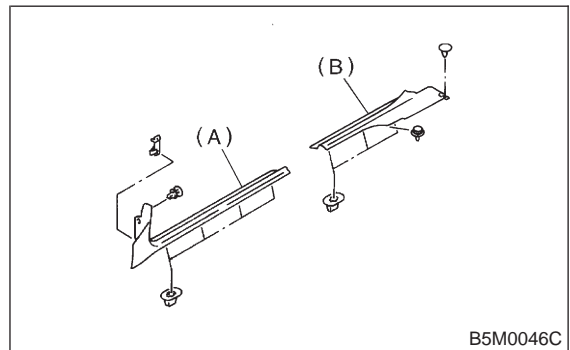

- 3) Installation is in the reverse order of removal.

2. CENTER PILLAR LOWER

- 1) Remove center pillar lower trim.

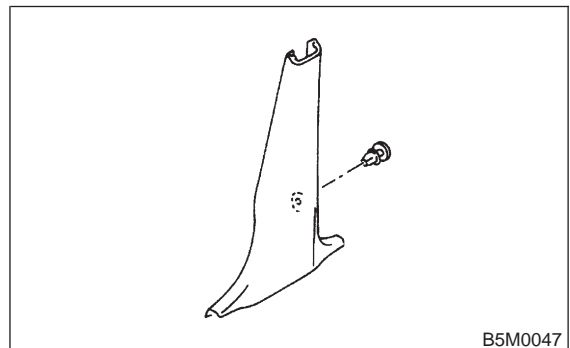

- 2) Installation is in the reverse order of removal.

3. CENTER PILLAR UPPER

NOTE:

<Ref. to 5-3 [C500].>

- 1) Remove front pillar upper trim.
- 2) Remove upper anchor of front seat belt.
- 3) Remove center pillar upper trim panel.

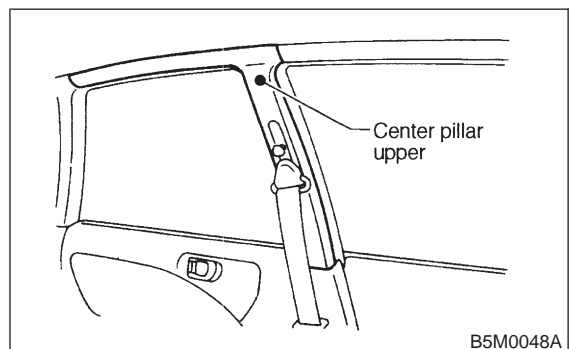

- 4) Installation is in the reverse order of removal.

- Ensure that tongues, buckles and belts are properly placed on seat.

5. Inner Trim Panel

A: REMOVAL AND INSTALLATION

1. SIDE SILL COVER

- 1) Remove front pillar lower trim (A).
- 2) Remove side sill rear upper cover trim (B).

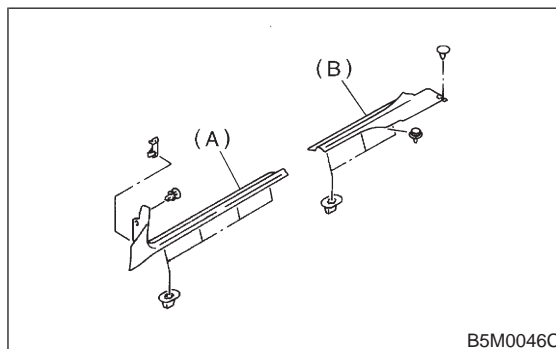

- 3) Installation is in the reverse order of removal.

2. CENTER PILLAR LOWER

- 1) Remove center pillar lower trim.

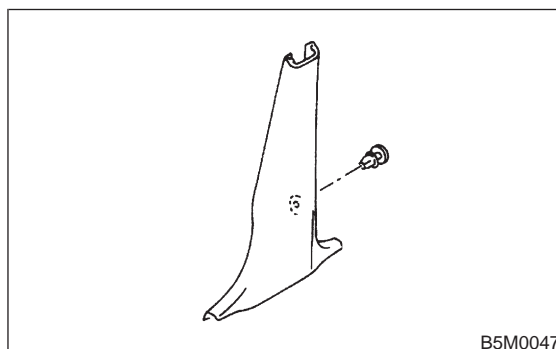

- 2) Installation is in the reverse order of removal.

3. CENTER PILLAR UPPER

NOTE:

<Ref. to 5-3 [C500].>

- 1) Remove front pillar upper trim.
- 2) Remove upper anchor of front seat belt.
- 3) Remove center pillar upper trim panel.

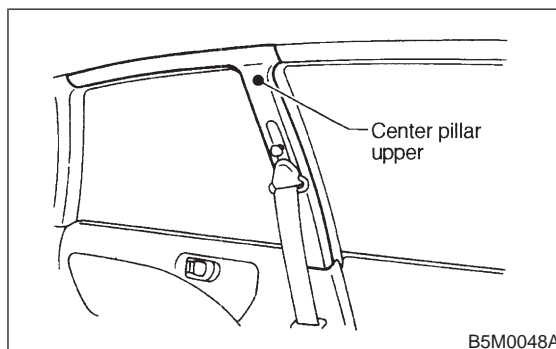

- 4) Installation is in the reverse order of removal.

CAUTION:

- The left and right ELR's are not mutually interchangeable because different sensors are used.
- Be careful not to twist belts during installation.

4. FRONT PILLAR UPPER

NOTE:

<Ref. to 5-3 [C500].>

- 1) Remove front pillar upper trim panel.

CAUTION:

Be sure to securely hook pawls of front pillar upper trim panel on body flange.

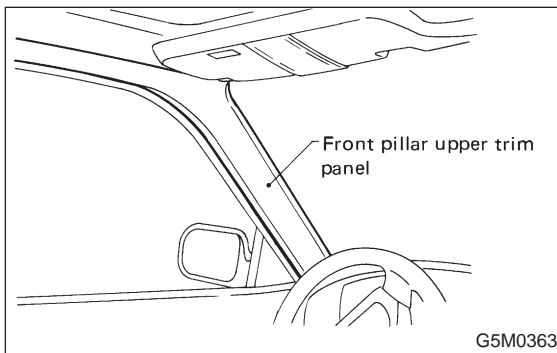

- 2) Installation is in the reverse order of removal.

5. REAR PILLAR UPPER

- 1) Remove rear seat cushion and backrest.
- 2) Remove rear seat belt. (Lower anchor bolt)
- 3) Remove rear pillar upper trim panel. <Ref. to 5-3 [C500].>

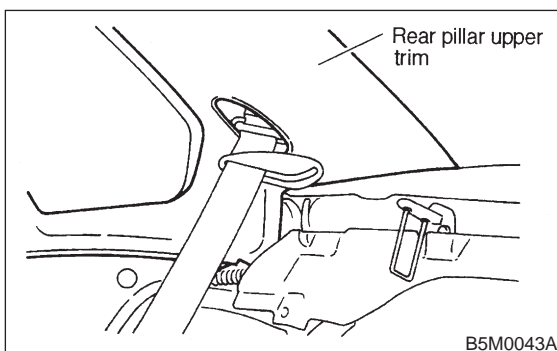

- 4) Installation is in the reverse order of removal.

CAUTION:

Be sure to securely hook pawls of rear pillar upper trim panel on body flange.

6. REAR PILLAR LOWER

NOTE:

<Ref. to 5-3 [C500].>

- 1) Remove side sill rear upper cover trim.

- 2) Remove rear pillar lower trim.

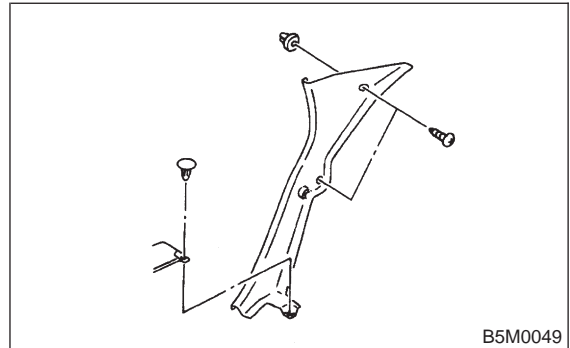

- 3) Installation is in the reverse order of removal.

7. REAR QUARTER PILLAR UPPER

NOTE:

<Ref. to 5-3 [C500].>

- 1) Remove rear seat belt. (Upper anchor bolt)
- 2) Remove cap strut.
- 3) Remove rear quarter upper front trim (A).
- 4) Remove rear quarter upper rear trim (B).

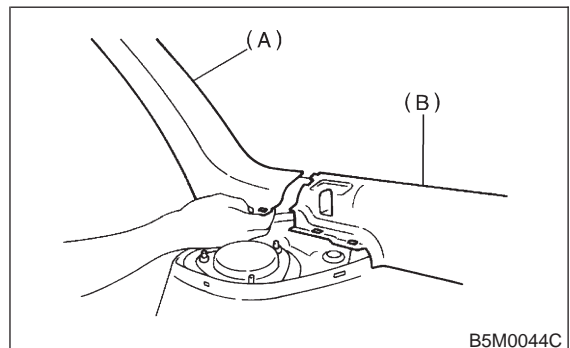

- 5) Installation is in the reverse order of removal.

CAUTION:

Be sure to securely hook pawls of rear quarter pillar trim panel on body flange.

8. REAR QUARTER PILLAR LOWER

NOTE:

<Ref. to 5-3 [C500].>

- 1) Set rear seat cushion up.
- 2) Remove side sill rear upper cover.
- 3) Remove rear seat belt. (Upper anchor and lower anchor bolts)
- 4) Remove side skirt trim.
- 5) Remove cap strut.
- 6) Remove rear quarter upper rear trim.

7) Remove rear quarter pillar lower trim.

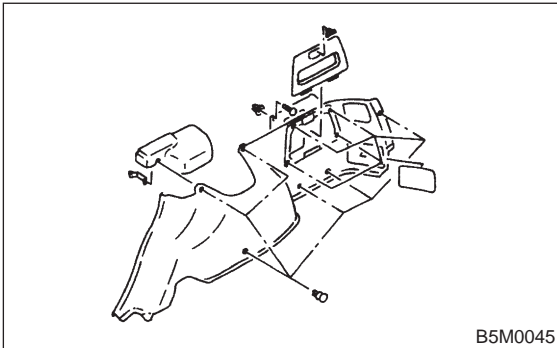

8) Installation is in the reverse order of removal.

CAUTION:

Be careful not to ride trim panel over harness, insulators, etc.

9. ROOF TRIM

NOTE:

<Ref. to 5-3 [C500].>

- 1) Remove room mirror, room light, sun visor and assist grip.
- 2) Remove front pillar upper, center pillar upper, rear quarter upper and rear rail trim.
- 3) Using ST, remove clips and then detach roof trim.

ST 925580000 PULLER

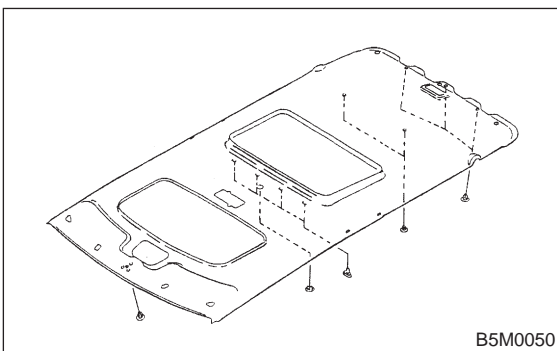

4) Installation is in the reverse order of removal.

CAUTION:

When removing clip, use great care to prevent damaging the roof trim.

10. FLOOR MAT AIRBAG

1) Supplemental Restraint System "Airbag" Airbag system wiring harness is routed near floor mat.

CAUTION:

- All Airbag system wiring harness and connectors are colored yellow. Do not use electrical test equipment on these circuit.
- Be careful not to damage Airbag system wiring harness when servicing floor mat.

2) The following procedure is applicable to all models:

NOTE:

<Ref. to 5-3 [C500].>

- (1) Remove front seats.
- (2) Remove rear seat cushion.
- (3) Remove console box.
- (4) Remove front pillar lower trim panel.
- (5) Remove center pillar lower trim panel.
- (6) Remove side sill cover.
- (7) Remove fuel opener cover.
- (8) Remove clip under front seat.
- (9) Remove clip in toe board area.

NOTE:

When pulling out edge, do not pull mat alone; pull mat together with edge.

Pry off two steel clips on side sill front cover and one on side sill rear cover using screwdriver.

- (10) Remove mat hook.
- (11) Remove mat from toe board area.
- (12) Remove mat from heater module.
- (13) Roll mat, and take it out of opened rear door.

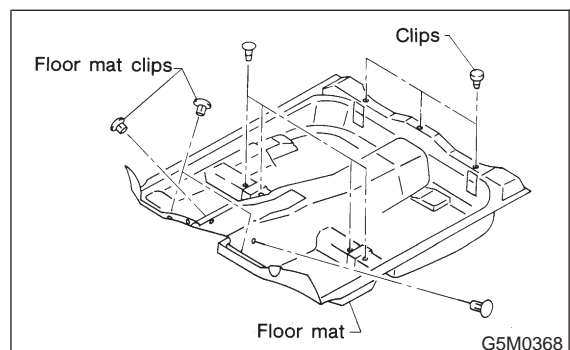

(14) Installation is in the reverse order of removal.

NOTE:

- Secure mat firmly with hook and velcro tape.
- Insert mat edge firmly into the groove of side sill cover.

MEMO:

1. Instrument Panel

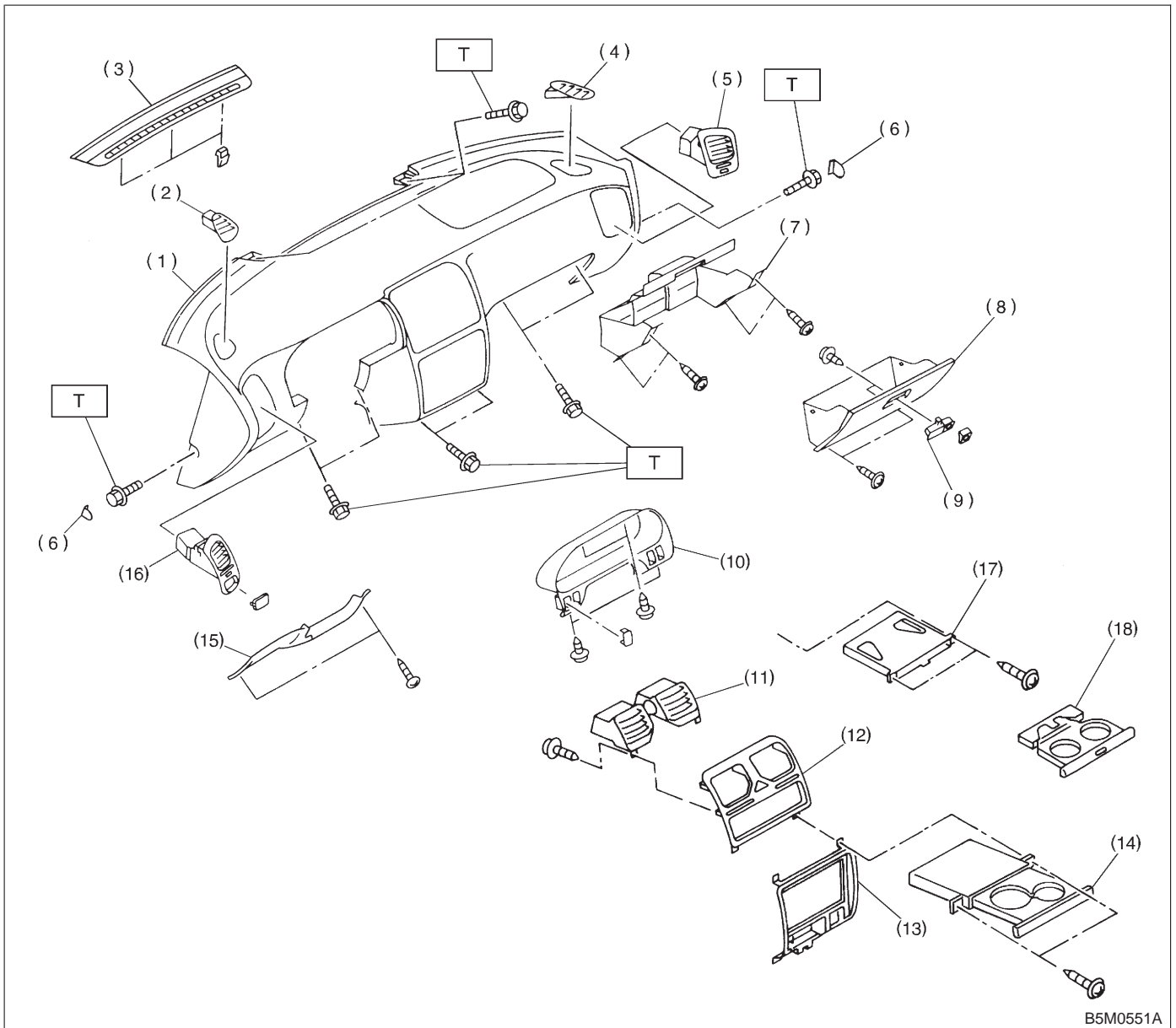

B5M0551A

- (1) Pad and frame
- (2) Grille SD def. (D)
- (3) Front def. grille
- (4) Grille SD def. (P)
- (5) Grille vent (P)
- (6) Cover
- (7) Cover back panel
- (8) Pocket ASSY

- (9) Lock ASSY
- (10) Meter visor
- (11) Grille CTR vent.
- (12) Panel CTR upper
- (13) Panel CTR lower
- (14) Cup holder ASSY
- (15) Panel lower cover
- (16) Grille SD vent. (D)

- (17) Cup holder BRKT
- (18) Cup holder

Tightening torque: N-m (kg-m, ft-lb)
T: 7±1 (0.7±0.1, 5.1±0.7)

2. Console Box

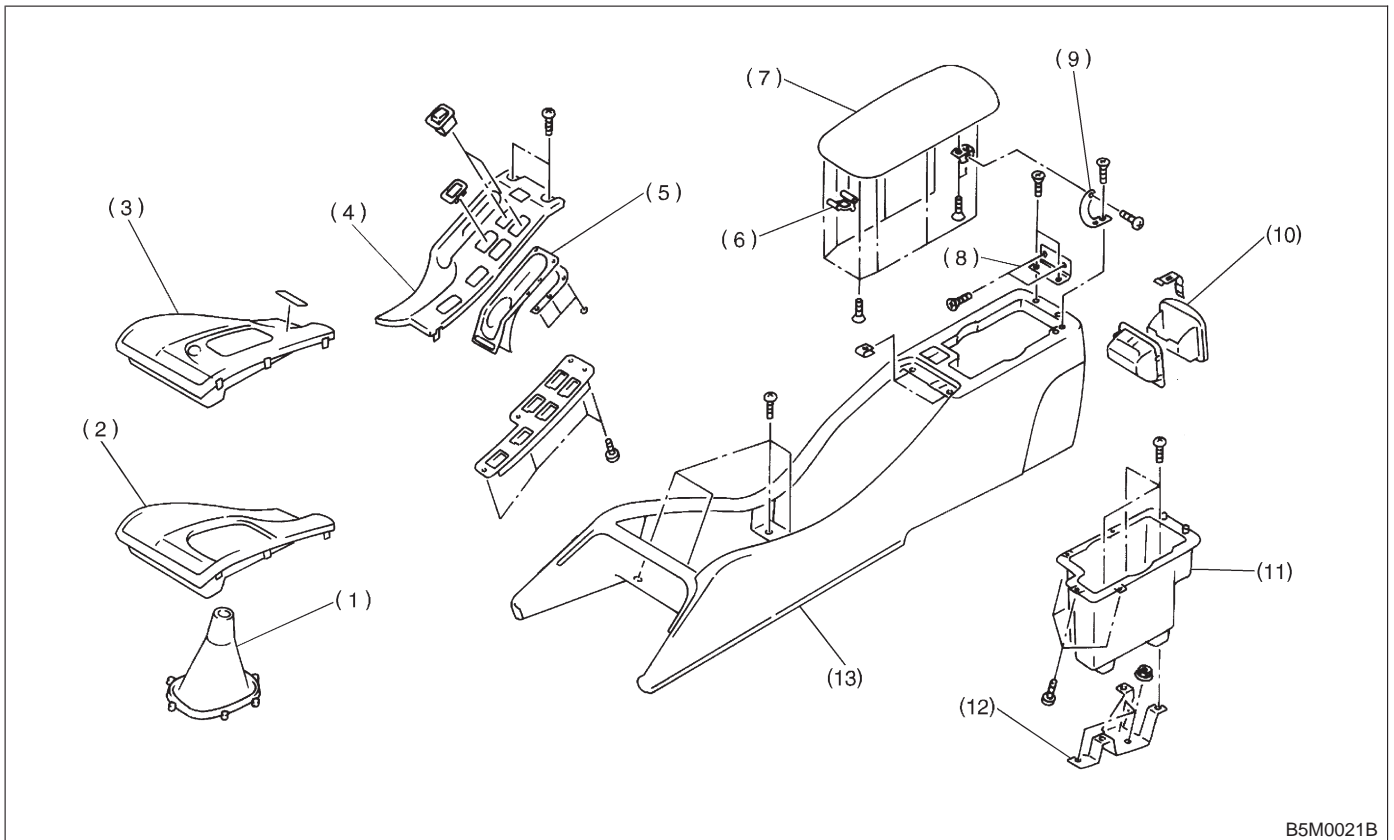

B5M0021B

- | | | |
|----------------------|--------------------|---------------------|
| (1) Shift boot | (6) Lock | (11) Console pocket |
| (2) Front cover (MT) | (7) Lid | (12) Console BRKT |
| (3) Front cover (AT) | (8) Hinge | (13) Console box |
| (4) Console cover | (9) Arm | |
| (5) Strip | (10) Ash tray ASSY | |

1. Instrument Panel **AIRBAG**

A: REMOVAL

Airbag system wiring harness is routed near combination meter.

CAUTION:

- All Airbag system wiring harness and connectors are colored yellow. Do not use electrical test equipment on these circuits.
- Be careful not to damage Airbag system wiring harness when servicing the combination meter.

- 1) Disconnect GND cable from battery.
- 2) Remove shift knob (MT model).
- 3) Remove console cover (A) and front cover (B).

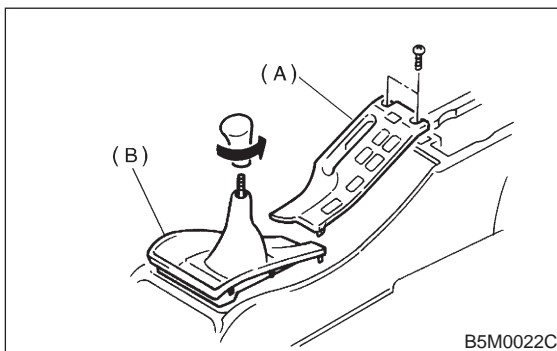

- 4) Remove console box.

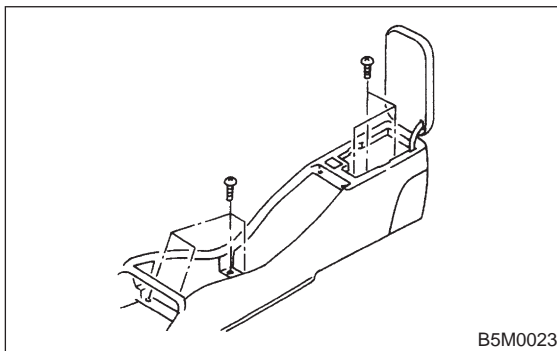

- 5) Remove lower cover and then disconnect connector.

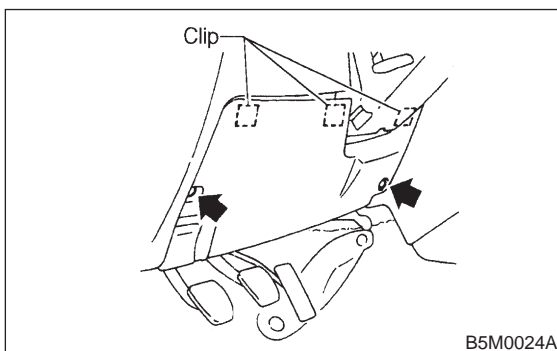

- 6) Remove glove box.

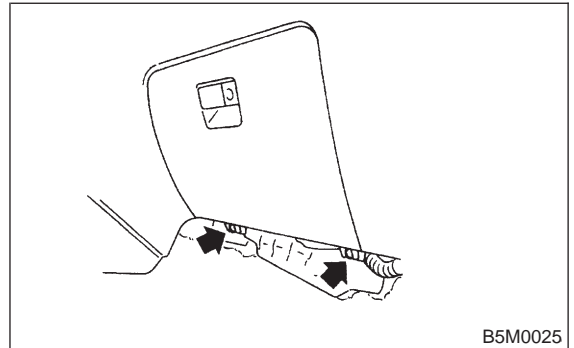

- 7) Remove cover back panel.

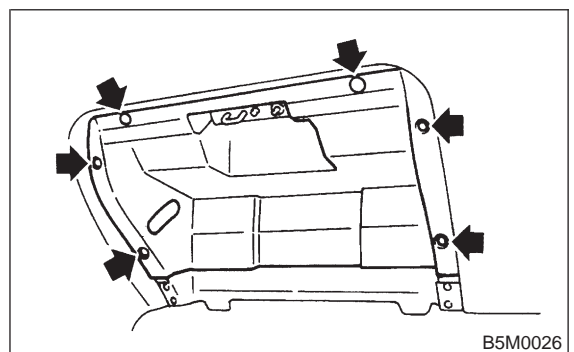

- 8) Remove two bolts and lower steering column.

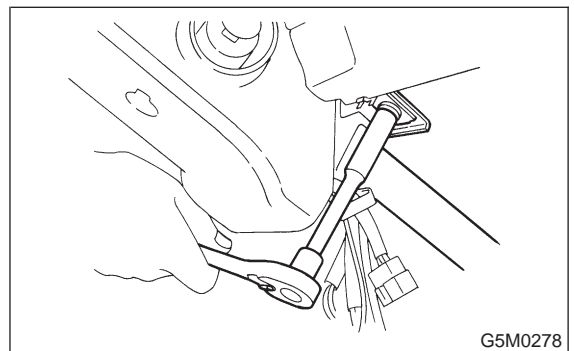

- 9) Set temperature control lever to Max. COLD position, and then disconnect temperature control cable from link of heater module.

NOTE:

Do not move lever and link when installing.

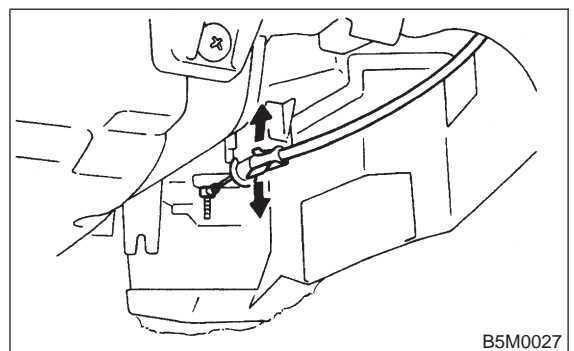

10) Remove bolt cover and bolt of both side.

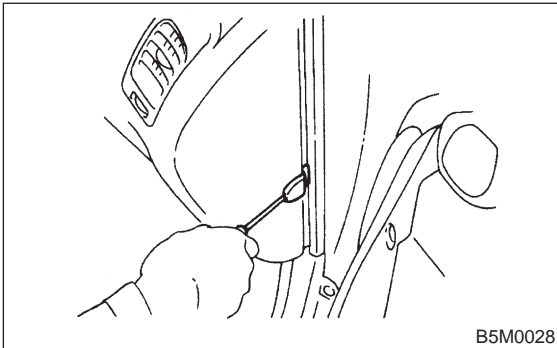

11) Remove front side sill cover RH and then disconnect airbag connector (AB9) and (AB10) (Airbag model). <Ref. to 5-5 [M200].>

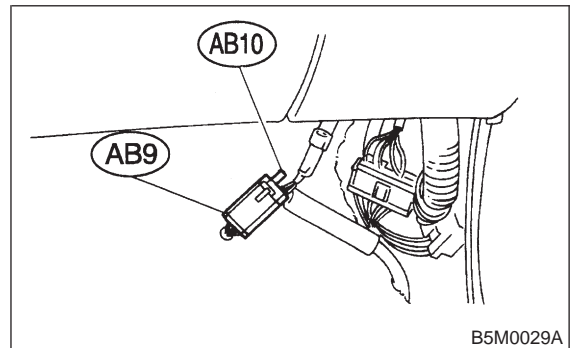

12) Disconnect harness connectors and then remove the installing bolt.

CAUTION:
Be sure to hold socket section and not harness when disconnecting.

NOTE:
Put matching mark, if necessary, for easy re-assembly.

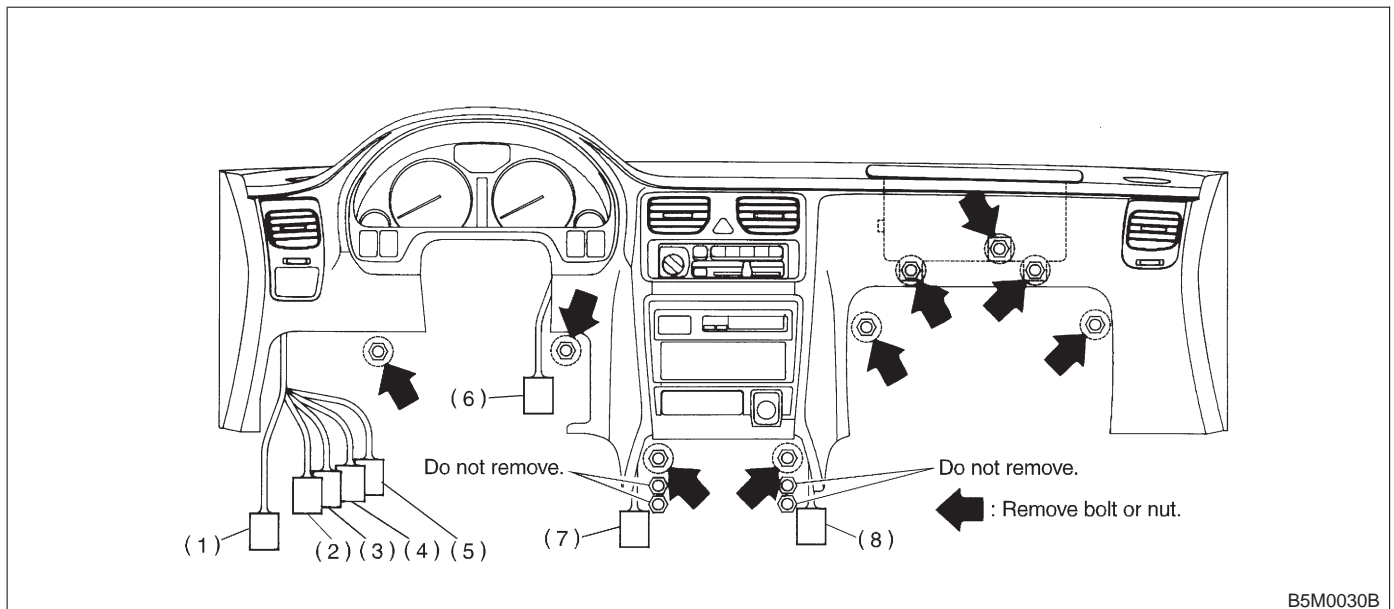

- (1) 15P/Gray
- (2) 22P/Brown
- (3) 22P/White

- (4) 20P/Blue
- (5) 22P/Black
- (6) 4P/Sky blue

- (7) 1P/Black
- (8) 1P/Black

1. Instrument Panel **AIRBAG**

13) Remove front defroster grille and two bolts.

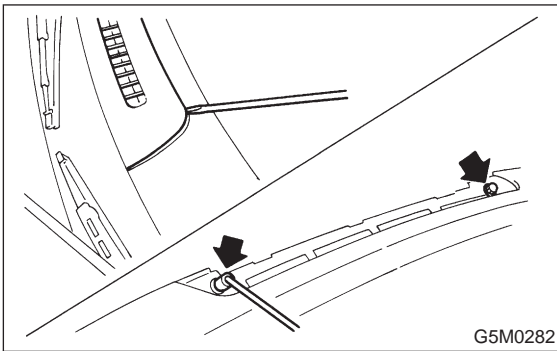

14) Remove instrument panel carefully from the body.

CAUTION:

- Take care not to scratch the instrument panel and related parts.
- When storing removed instrument panel with passenger airbag module, place it standing up on the floor.

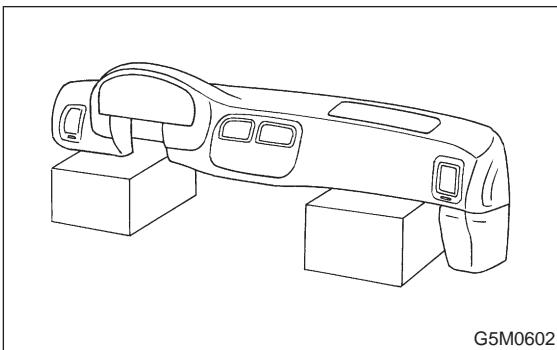

B: INSTALLATION

Installation is in the reverse order of removal.

CAUTION:

- Be careful not to snag the harness.
- Make sure to connect harness connectors.
- Take care not to scratch the instrument panel and related parts.

NOTE:

- When setting instrument panel into position, push two pins into grommet on body panel.

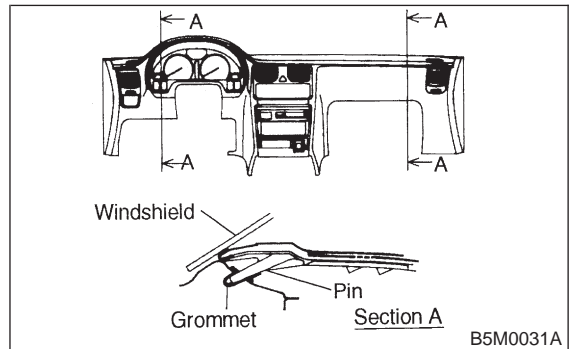

- Set clips located at both inside ends of instrument panel onto body side.

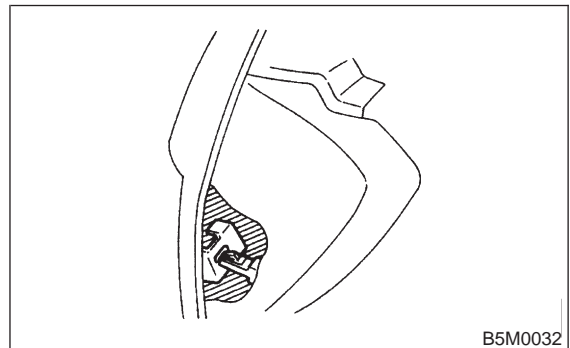

1. SRS Airbag

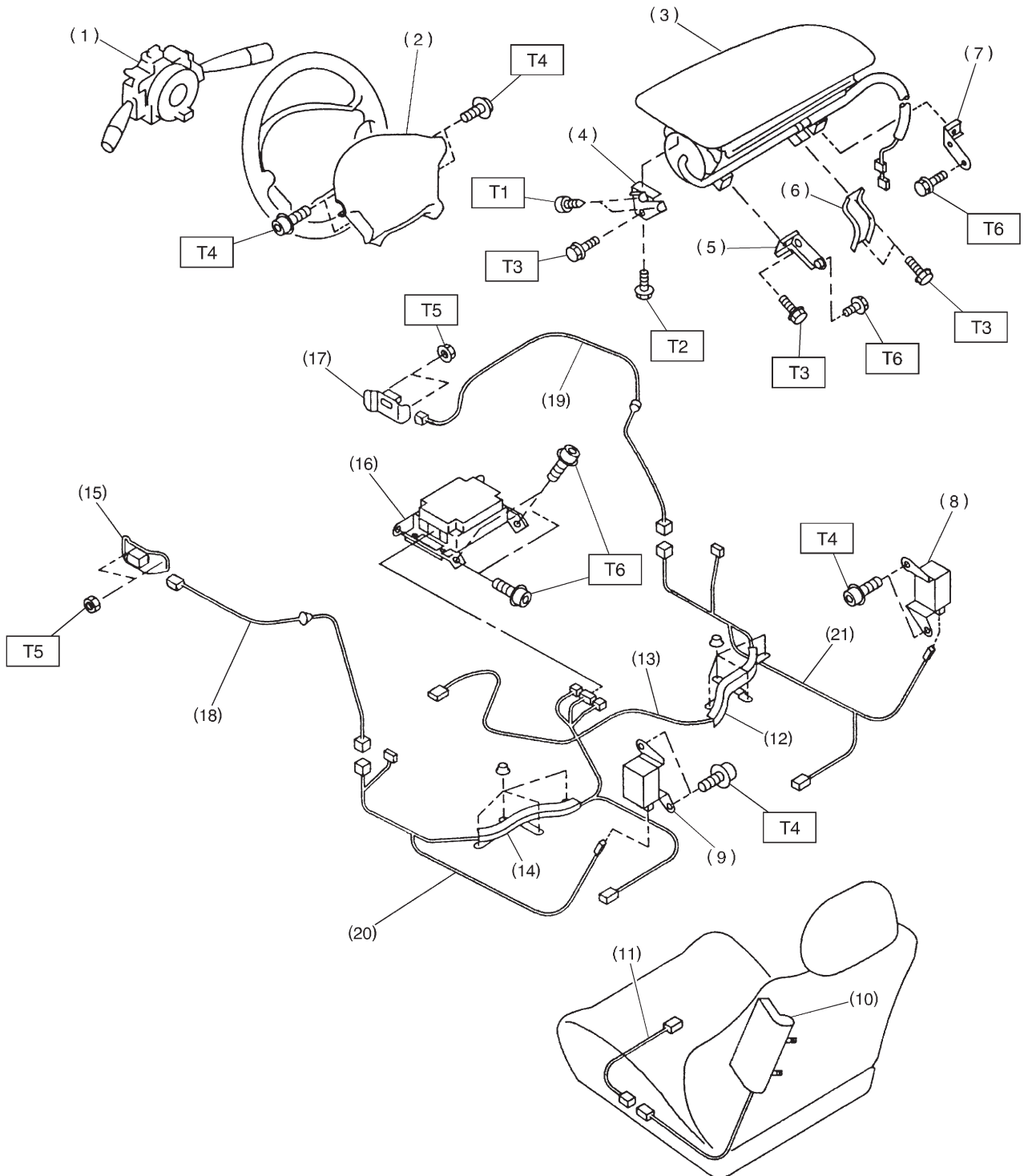

COMPONENT PARTS

[C100] **5-5**
1. SRS Airbag

- (1) Combination switch ASSY with roll connector
- (2) Airbag module ASSY (Driver)
- (3) Airbag module ASSY (Passenger)
- (4) BRKT SD A
- (5) BRKT P AB (LH)
- (6) BRKT B
- (7) BRKT P AB (RH)
- (8) Side airbag sensor (RH)
- (9) Side airbag sensor (LH)

- (10) Airbag module ASSY (Side)
- (11) Extension harness
- (12) Protector RH
- (13) Airbag main harness
- (14) Protector LH
- (15) Front sub sensor (LH)
- (16) Airbag control module
- (17) Front sub sensor (RH)
- (18) Front sub sensor harness (LH)
- (19) Front sub sensor harness (RH)
- (20) Side airbag harness (LH)

- (21) Side airbag harness (RH)

Tightening torque: N-m (kg-m, ft-lb)

T1: 1.8±0.5 (0.18±0.05, 1.3±0.4)

T2: 4.4±1.5 (0.45±0.15, 3.3±1.1)

T3: 7.4±0.5 (0.75±0.05, 5.4±0.4)

T4: 10±2 (1.0±0.2, 7.2±1.4)

T5: 20±4 (2.0±0.4, 14.5±2.9)

T6: 32±10 (3.3±1.0, 23.9±7.2)

1. Precaution

- If any of the airbag system parts such as sensors, airbag module, airbag control module and harness are damaged or deformed, replace with new genuine parts.

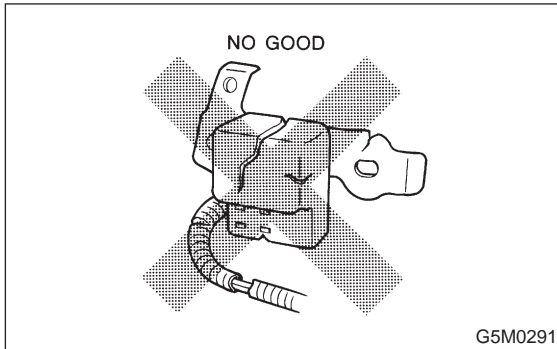

- When servicing, be sure to turn the ignition switch off, disconnect the negative (-) battery terminal then the positive (+) terminal in advance, and wait for more than 20 seconds before starting work.

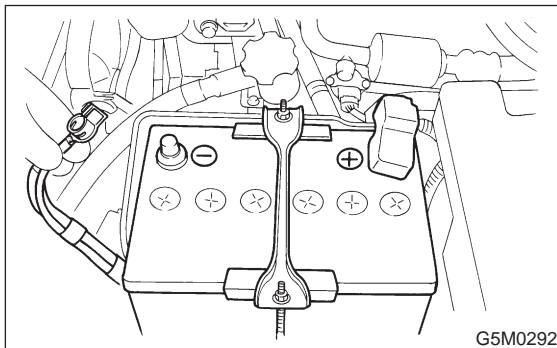

- When checking the system, be sure to use a digital circuit tester. Use of an analog circuit tester may cause the airbag to activate erroneously. Do not directly apply the tester probe to any connector terminal of the airbag. When checking, use a test harness.

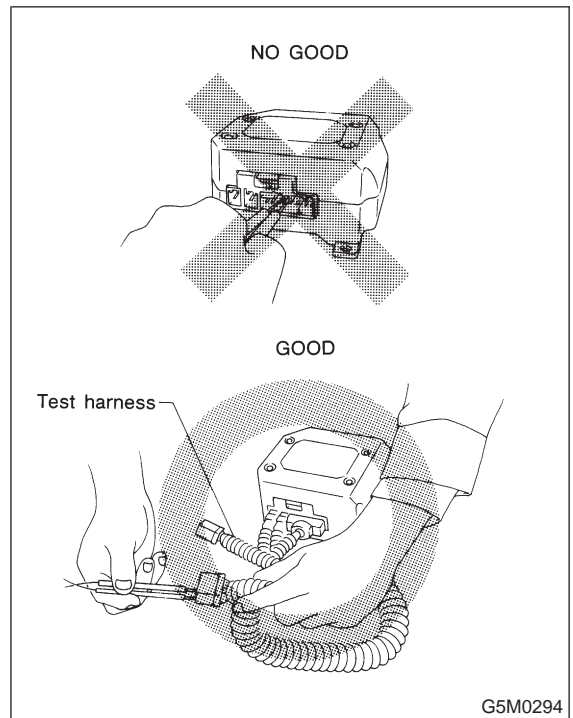
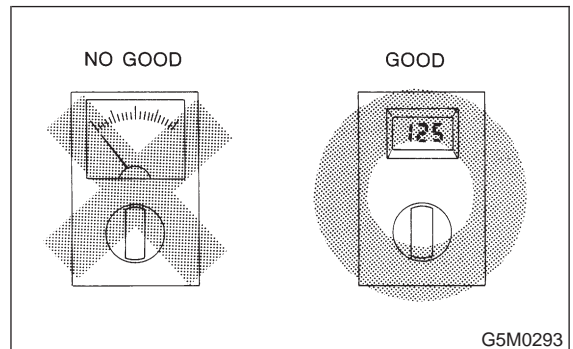

- Do not drop the airbag modulator parts, subject it to high temperatures over 90°C (194°F), or apply oil, grease, or water to it; otherwise, the internal parts may be damaged and its reliability greatly lowered.

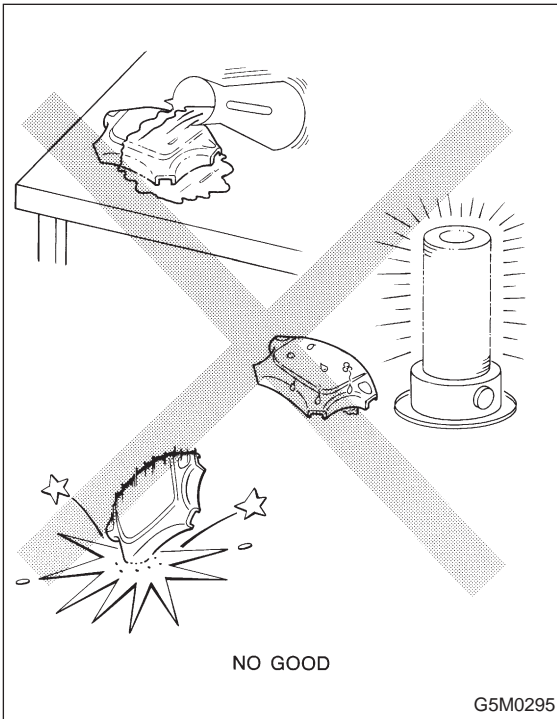

- If any damage or open is found on the SRS airbag system wire harness, do not attempt to repair using soldering, etc. Be sure to replace the faulty harness with a new genuine part.

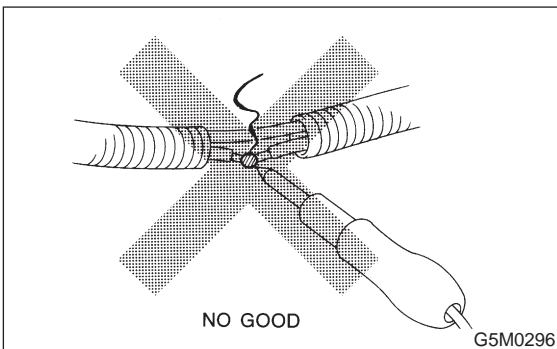

- Install the wire harness securely with the specified clips so as to avoid interference or jamming with other parts.

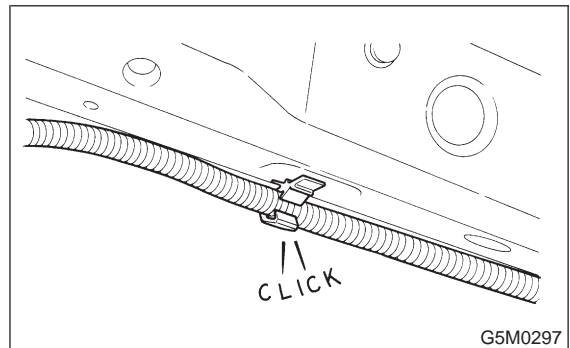

- Before connecting the airbag system to ground, make sure that the grounding terminal is free from paint and contamination.
- Do not allow water or oil to come in contact with the connector terminals. Do not touch the connector terminals.

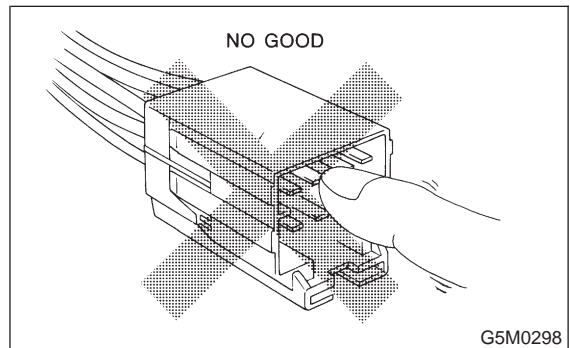

- When connecting or disconnecting airbag connector, make sure ignition switch is OFF.

2. Inspection and Replacement Standards

A: VEHICLES WHICH BECOME INVOLVED IN A COLLISION

If the vehicle equipped with an SRS airbag system is damaged in a collision, the airbag system parts must be checked and replaced in accordance with the following standards:

- After faulty parts are replaced, the warning light operation must be checked.
- When the ignition switch is turned ON, it lights up for about 7 seconds and then it goes out for at least 30 seconds.
- The trouble code stored in memory must be erased after the check.

B: AIRBAG MODULE (DRIVER AND PASSENGER)

1. INSPECTION STANDARD

- The vehicle damaged in a frontal collision (regardless of whether or not airbag is deployed).
- The designated trouble code is output during self-diagnosis. <Ref. to 5-5 [T400].>

2. REPLACEMENT STANDARD

- Airbag is deployed.
- The pad surface is scratched or cracked.
- Harness and/or connector is deformed or cracked, their circuits are broken, lead wire is exposed, etc.
- Mounting bracket is cracked or deformed.
- The module surface is fouled with foreign matter. (grease, oil, water, cleaning solvent, etc.)
- Airbag module dropped to the floor/ground.
- Airbag module determined as faulty during self-diagnosis.

C: AIRBAG MODULE (SIDE)

1. INSPECTION STANDARD

- The vehicle damaged in a side collision (regardless of whether or not airbag is deployed).
- The designated trouble code is output during self-diagnosis. <Ref. to 5-5 [T400].>

2. REPLACEMENT STANDARD

- Airbag is deployed.
- The front seat assembly is damaged or deformed.
- Harness and/or connector is deformed or cracked, their circuits are broken, lead wire is exposed, etc.
- Mounting bracket is cracked or deformed.

- Airbag module determined as faulty during self-diagnosis.

D: MAIN HARNESS

1. INSPECTION STANDARD

- A vehicle damaged in a collision (regardless of whether or not airbag is deployed).
- The designated trouble code is output during self-diagnosis. <Ref. to 5-5 [T400].>

2. REPLACEMENT STANDARD

- Harness circuit is broken, lead wire is exposed, corrugated tube is cracked, etc.
- Connector is scratched or cracked.
- The designated trouble code is output during self-diagnosis.

E: AIRBAG CONTROL MODULE

1. INSPECTION STANDARD

- A vehicle damaged in a collision (regardless of whether or not airbag is deployed).
- The designated trouble code is output during self-diagnosis. <Ref. to 5-5 [T400].>

2. REPLACEMENT STANDARD

- Control module is cracked or deformed.
- Mounting bracket is cracked or deformed.
- Connector is scratched or cracked.
- Control module dropped to the floor/ground.
- Control module determined as faulty during diagnostics.
- Airbag is deployed.

F: COMBINATION SWITCH

1. INSPECTION STANDARD

- A vehicle damaged in a collision (regardless of whether or not airbag is deployed).
- The designated trouble code is output during self-diagnosis. <Ref. to 5-5 [T400].>

2. REPLACEMENT STANDARD

Combination switch or steering roll connector is deformed or cracked.

G: STEERING WHEEL

1. INSPECTION STANDARD

A vehicle damaged in a collision (regardless of whether or not airbag is deployed).

2. REPLACEMENT STANDARD

- Check steering wheel insert for cracks or deformities.
- Check to ensure that new airbag module is properly installed in steering wheel.
- After installing airbag module, check to ensure that it is free of interference with steering wheel and that clearance between the two is equal at all points.

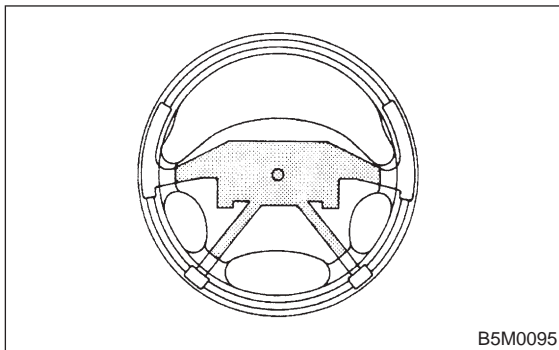

H: STEERING COLUMN ASSEMBLY

1. INSPECTION STANDARD

A vehicle damaged in a collision (regardless of whether or not airbag is deployed).

2. REPLACEMENT STANDARD

- Check steering wheel free play in axial and radial directions.

Specifications:

Axial free play A

Less than ±6 mm (0.24 in)

Radial free play L

Less than ±7 mm (0.28 in)

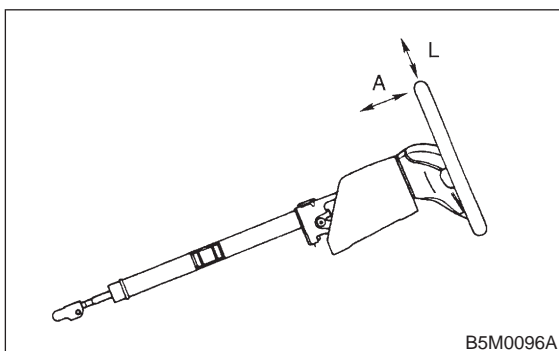

- Check to ensure that clearance between capsule (A) (at steering column) and cutout portion of column bracket (B) on steering column upper side is within specifications.

Clearance between capsule and cutout portion of column bracket: L

Less than 0.5 mm (0.020 in)

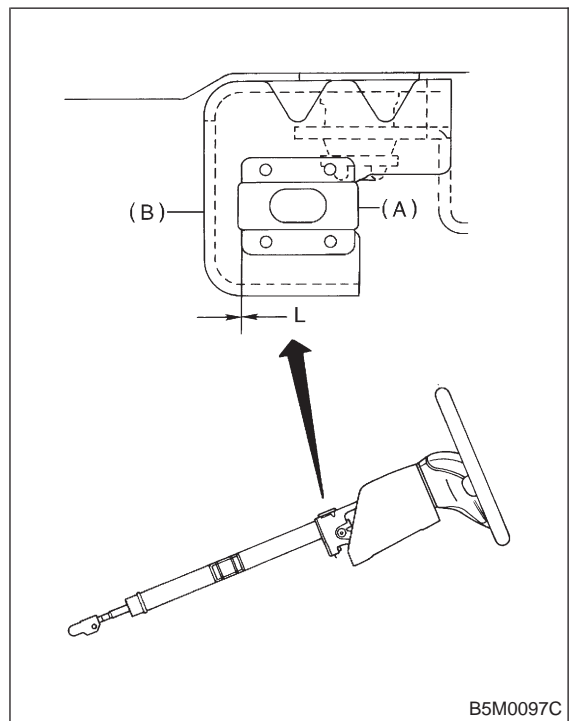

I: FRONT SUB SENSOR**1. INSPECTION STANDARD**

- Check the front section (Refer to shaded area of vehicle in figure) for damage, regardless of whether or not airbag is deployed.

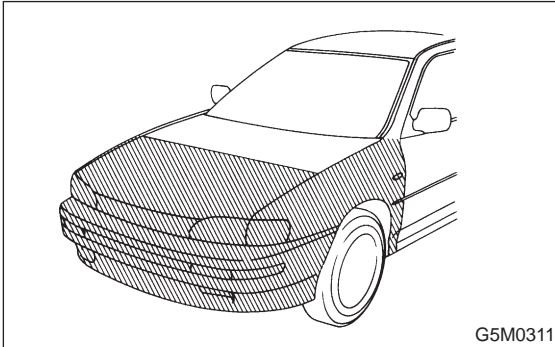

- The designated trouble code is output during self-diagnosis. <Ref. to 5-5 [T400].>

2. REPLACEMENT STANDARD

- Bracket is deformed.
- Housing is cracked or deformed.
- The label (that identifies the manufacturing number) is peeled or deteriorated.
- Harness circuit is broken, lead wire is exposed, corrugated tube is cracked, etc.
- Front sub sensor determined as faulty as a result of Diagnostics.
- Airbag is deployed.
- Front sub sensor dropped to the floor/ground.

J: SIDE AIRBAG SENSOR**1. INSPECTION STANDARD**

- Check the side section (Refer to shaded area of vehicle in figure) for damage, regardless of whether or not airbag is deployed.

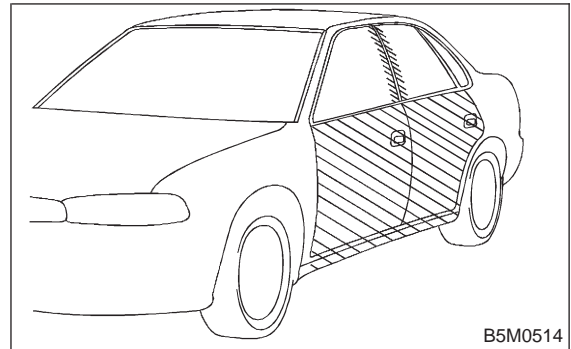

- The designated trouble code is output during self-diagnosis. <Ref. to 5-5 [T400].>

2. REPLACEMENT STANDARD

- Bracket is deformed.
- Housing is cracked or deformed.
- The label (that identifies the manufacturing number) is peeled or deteriorated.
- Harness circuit is broken, lead wire is exposed, corrugated tube is cracked, etc.
- Side airbag sensor determined as faulty as a result of Diagnostics.
- Airbag is deployed.
- Side airbag sensor dropped to the floor/ground.

3. Airbag Module

A: REMOVAL AND INSTALLATION

CAUTION:

- The airbag module (driver, passenger and side) must not be disassembled. The airbag module cannot be used again once inflated.

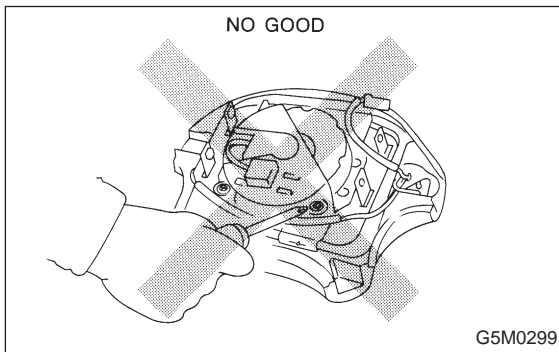

- When removing and installing the airbag module (driver, passenger and side), the operator should stand, as much as possible, on the side of the airbag module.

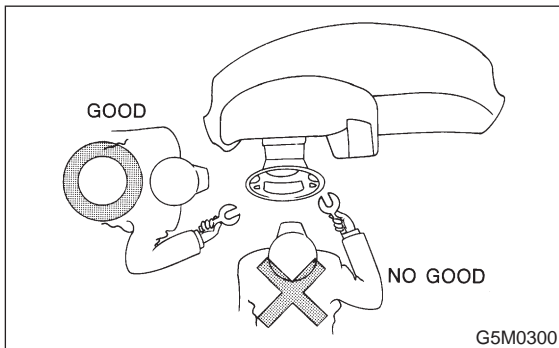

- After removal, the airbag module (driver, passenger and side) should be kept away from heat and light sources, and stored on a clean, flat surface to prevent from any damage to its lower structure.

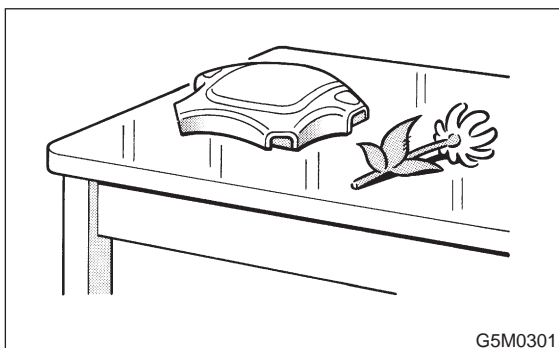

- Do not check airbag module (driver, passenger and side) continuity with airbag removed from the vehicle body.

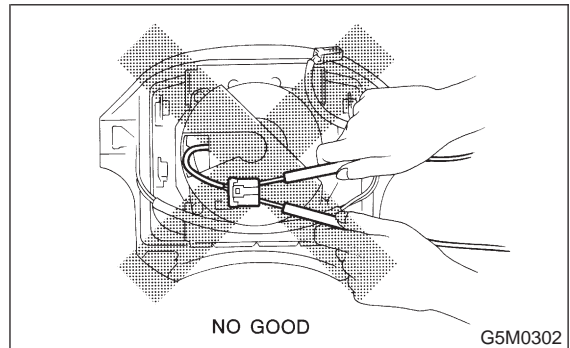

- Replace airbag module (driver, passenger and side) with a new one, should any of the following conditions develop:
 - Pad surface is scratched or cracked.
 - Connector harness is damaged.
 - Inflator side structure of module is cracked or deformed.
 - Module is excessively stained with water, oil, etc.
 - Module was accidentally dropped.
 - The front seat assembly is damaged or deformed.
- The removed front seat with the airbag module must be kept on its back. At this time, keep the module side at least 200 mm (7.87 in) away from walls or other objects.

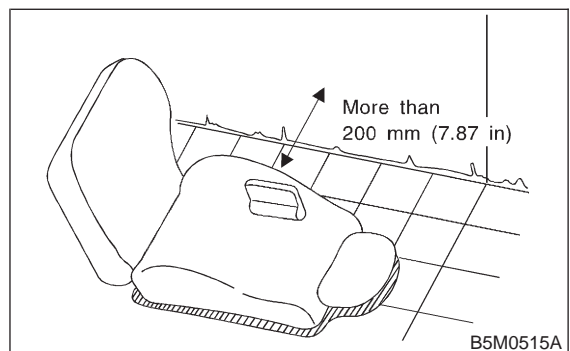

- When storing a removed airbag module (driver and passenger), be sure to place it in parallel with floor with the pad facing up. Do not place it against a wall, or place anything on the pad; otherwise, a dangerous condition may be created if the module malfunctions.

Driver side

GOOD

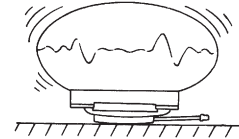
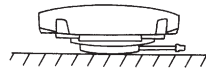

NO GOOD

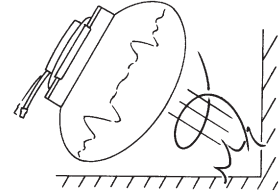
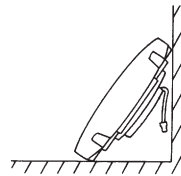

NO GOOD

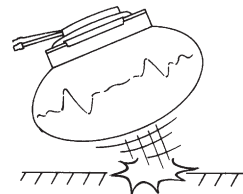
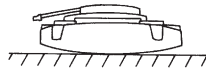

NO GOOD

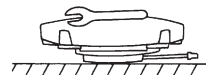

Passenger side

GOOD

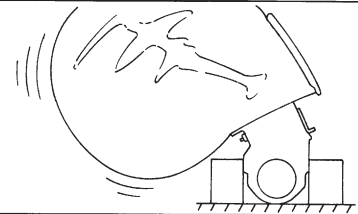
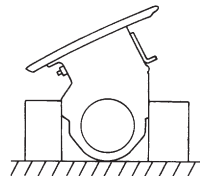

NO GOOD

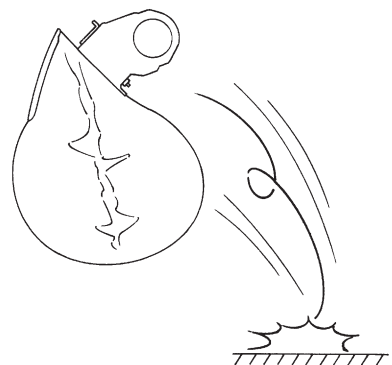
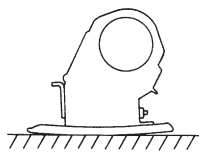

NO GOOD

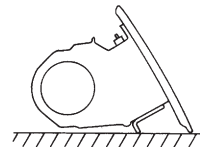

1. DRIVER'S AIRBAG MODULE

- 1) Set front wheels in straight ahead position.
- 2) Turn ignition switch off.
- 3) Disconnect ground cable from battery and wait for at least 20 seconds before starting work.

- 4) Using TORX® BIT T30, remove two TORX® bolts.

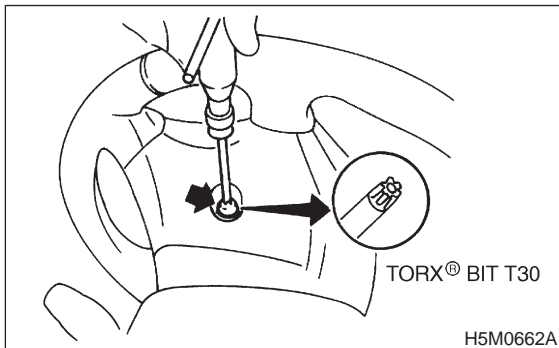

- 5) Disconnect airbag connector on back of airbag module. <Ref. to 5-5 [M2F2].>

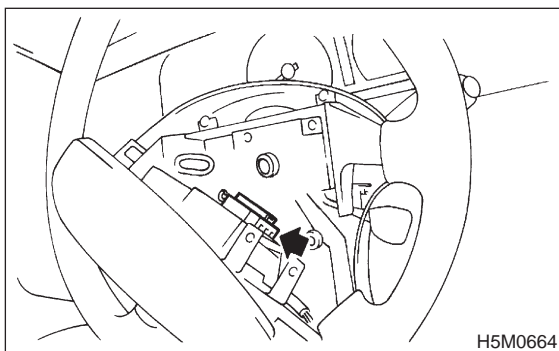

- 6) Refer to “**CAUTION**” for handling of a removed airbag module. <Ref. to 5-5 [W3A0].>
7) Installation is in the reverse order of removal.

CAUTION:
Do not allow harness and connectors to interfere or get caught with other parts.

2. PASSENGER’S AIRBAG MODULE

- 1) Remove instrument panel. <Ref. to 5-4 [W1A0].>
2) Remove four bolts and then carefully remove airbag module.

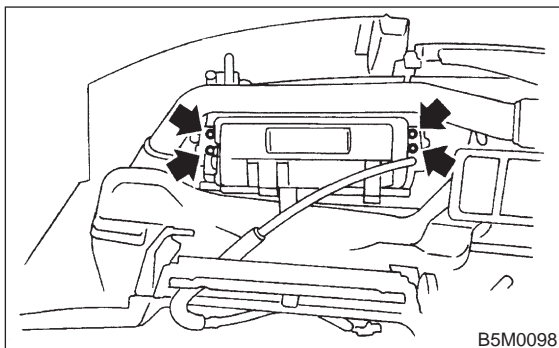

- 3) Refer to “**CAUTION**” for handling of a removed airbag module. <Ref. to 5-5 [W3A0].>
4) Installation is in the reverse order of removal.

CAUTION:
Do not allow harness and connectors to interfere or get caught with other parts.

3. SIDE AIRBAG MODULE

The side airbag module cannot be detached from the front seat assembly. When replacing side airbag module, replace front seat assembly. <Ref. to 5-3 [W1A0].>

4. Main Harness

A: REMOVAL AND INSTALLATION

- 1) Turn ignition switch off.
- 2) Disconnect ground cable from battery and wait for at least 20 seconds before starting work.
- 3) Remove lower cover. <Ref. to 5-4 [W1A0].> Disconnect airbag connector (AB3) and (AB8) below steering column.

CAUTION:

Do not reconnect airbag connector at steering column until main harness are securely re-installed.

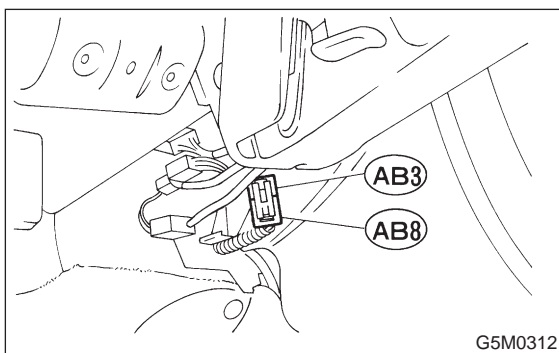

- 4) Remove console box. <Ref. to 5-4 [W1A0].>
- 5) Disconnect connector from airbag control module.
- 6) Disconnect body harness connector (B31) from connector (AB1).

NOTE:

The following procedures for removal are for "LHD model". The procedures for "RHD model" are symmetrically opposite.

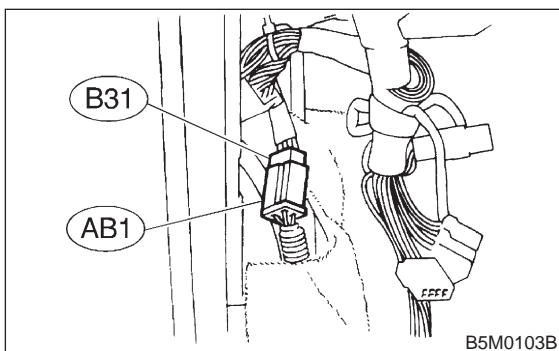

- 7) Remove front side sill cover and then disconnect airbag connector (AB9) and (AB10). <Ref. to 5-5 [M2F2].>

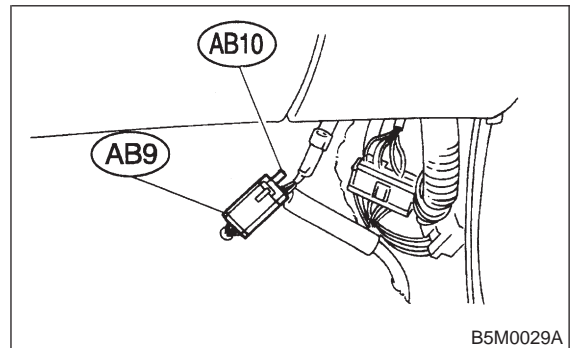

- 8) Roll up floor mat and side sill lower cover of both side and then remove main harness.

- 9) Disconnect front sub sensor connector (A), side airbag sensor connector (B) (side airbag equipped model) and then remove protector (C).
- 10) Detach clips and then remove airbag main harness.

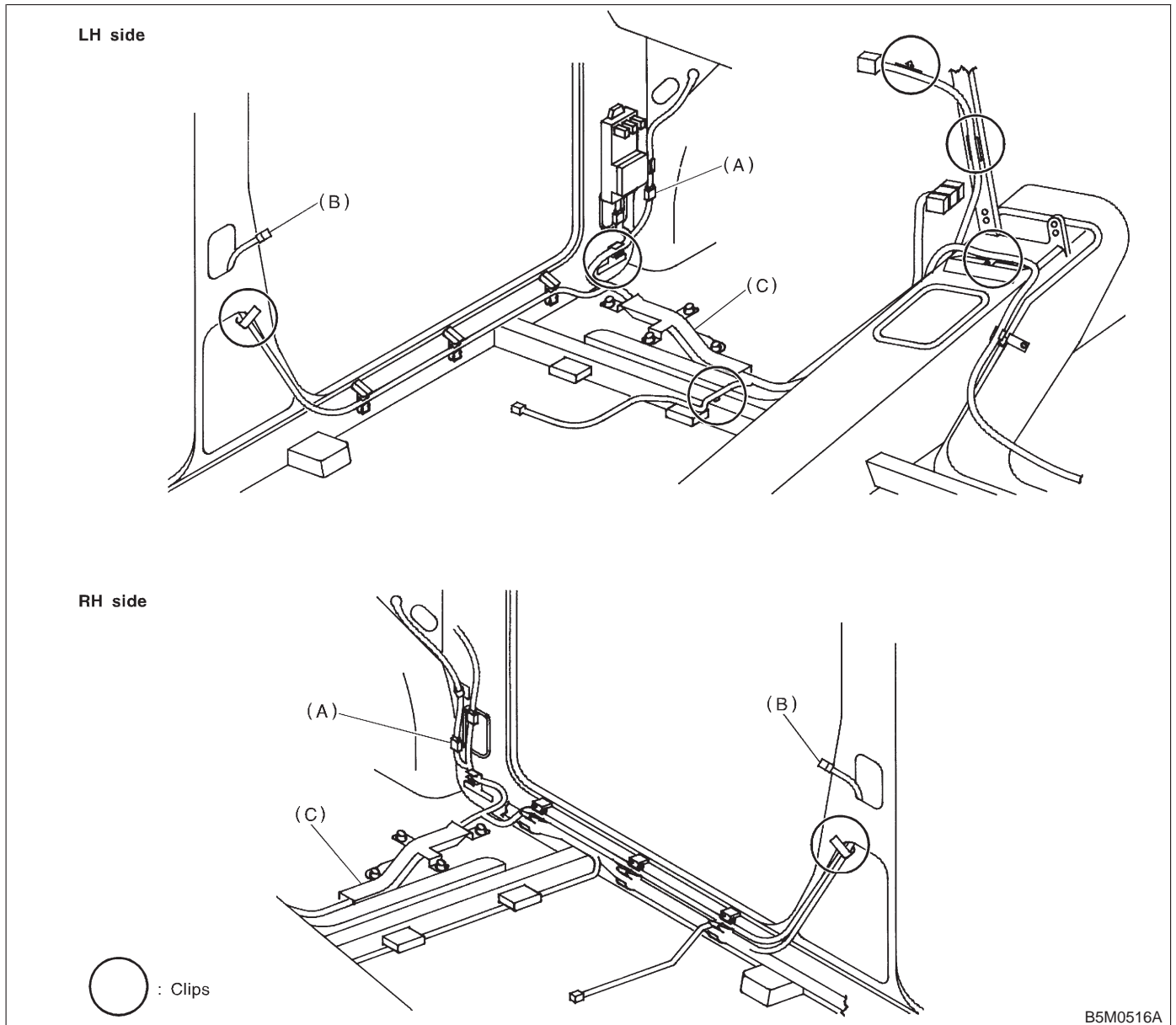

- 11) Installation is in the reverse order of removal.

5. Airbag Control Module

A: REMOVAL AND INSTALLATION

CAUTION:

- Do not disassemble the airbag control module.

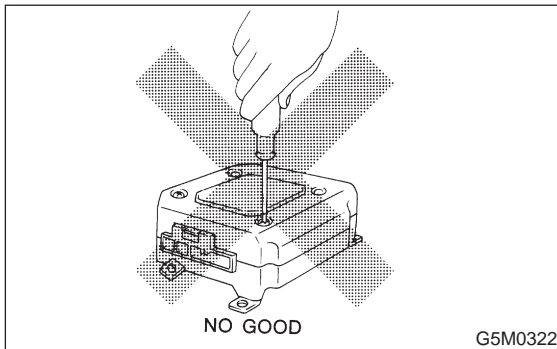

- If the airbag control module is deformed, or if water damage is suspected, replace the airbag control module with a new genuine part.



- After removal, keep the airbag control module on a dry, clean surface away from heat and light sources, and moisture and dust.

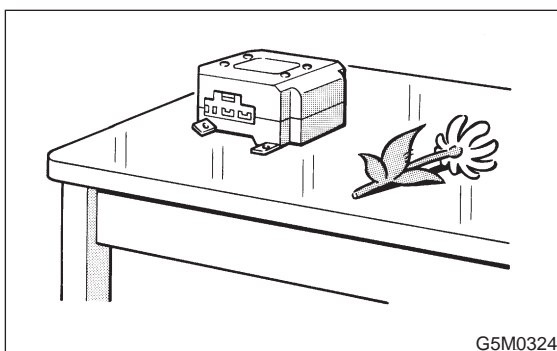

- 1) Turn ignition switch off.
- 2) Disconnect ground cable from battery and wait for at least 20 seconds before starting work.

- 3) Remove lower cover. <Ref. to 5-4 [W1A0].> Disconnect airbag connector (AB3) and (AB8) below steering column.

CAUTION:

Do not reconnect airbag connector at steering column until airbag control module is securely re-installed.

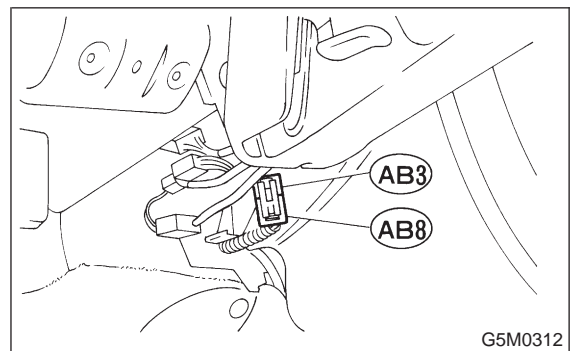

- 4) Remove console box. <Ref. to 5-4 [W1A0].>
- 5) Disconnect connector from airbag control module.
- 6) Using TORX® BIT T40 (Tamper resistant type), remove two TORX® bolts. Discard the old TORX® bolts.

CAUTION:

Use new TORX® bolts during re-assembly.

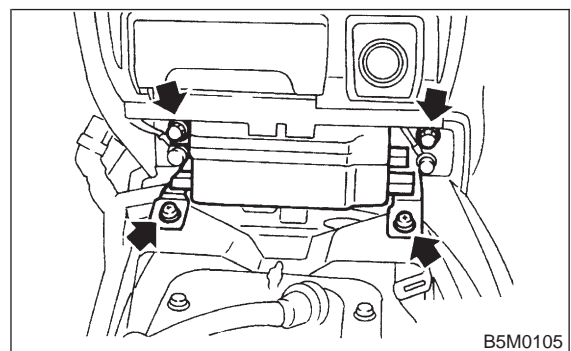

- 7) Installation is in the reverse order of removal.

6. Combination Switch

A: REMOVAL

- 1) Turn ignition switch off.
- 2) Disconnect ground cable from battery and wait for at least 20 seconds before starting work.
- 3) Remove lower cover. <Ref. to 5-4 [W1A0].> Disconnect airbag connector (AB3) and (AB8) below steering column.

CAUTION:
Do not reconnect airbag connector at steering column until combination switch is securely re-installed.

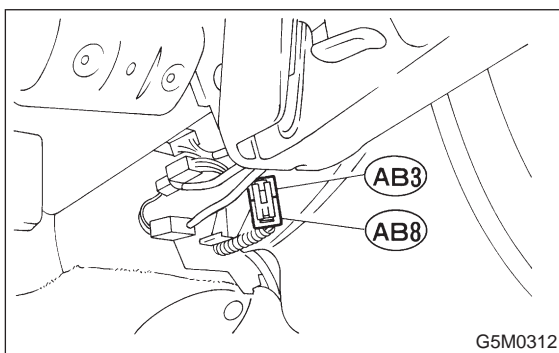

- 4) Disconnect combination switch connectors from body harness connector.
- 5) Set front wheels in straight ahead position. Using TORX® BIT T30, remove two TORX® bolts.

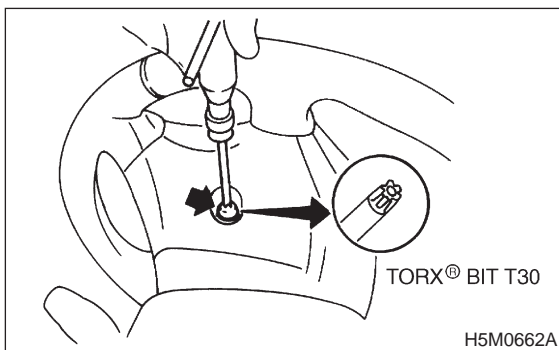

- 6) Disconnect airbag connector on back of airbag module. <Ref. to 5-5 [M2F2].> Remove airbag module, and place it with pad side facing upward. <Ref. to 5-5 [W3A0].>

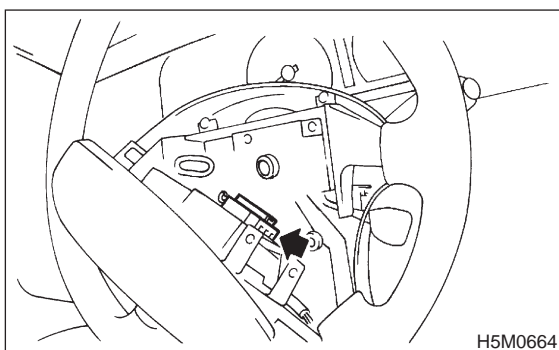

- 7) Using steering puller, remove steering wheel.

CAUTION:
Do not allow connector to interfere when removing steering wheel.

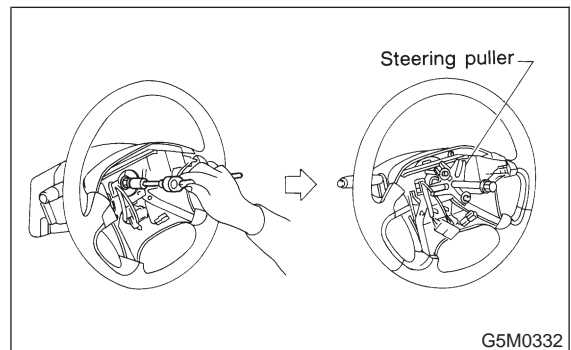

- 8) Remove steering column covers.
- 9) Removing two retaining screws, remove combination switch.

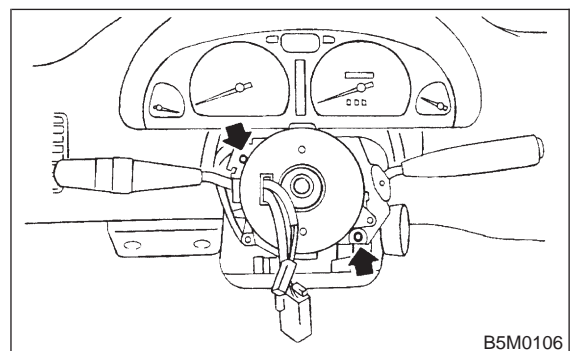

B: ADJUSTMENT

1. CENTERING ROLL CONNECTOR

Before installing steering wheel, make sure to center roll connector built into combination switch.

- 1) Make sure that front wheels are positioned straight ahead.
- 2) Install steering gearbox, steering shaft and combination switch properly. Turn roll connector pin (A) clockwise until it stops.
- 3) Then, back off roll connector pin (A) approximately 2.65 turns until "▲" marks aligned.

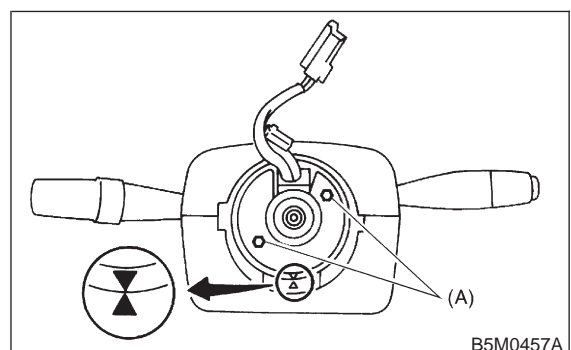

C: INSTALLATION

CAUTION:

Failure to do this might damage roll connector.

- 1) Before installing combination switch, check to ensure that combination switch is off and front wheels are set in the straight ahead position.
- 2) Install column cover and center roll connector.
- 3) Install steering wheel in neutral position. Carefully insert roll connector pin (A) into hole on steering wheel.

NOTE:

If steering wheel angle requires fine adjustment, adjust tie-rod. <Ref. to 4-3 [W3F0].> and <Ref. to 4-3 [W4F0].>

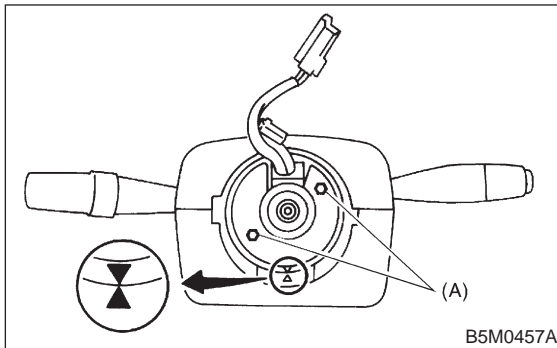

- 4) Install airbag module and lower cover in the reverse order of removal.

7. Front Sub Sensor

A: REMOVAL AND INSTALLATION

CAUTION:

- If the front end of the vehicle body is damaged by a collision, be sure to check the left and right front sub sensors, even if the airbag was not inflated. If any damage to the sensor or any deformation of the sensor mount is found, replace with a new genuine part.

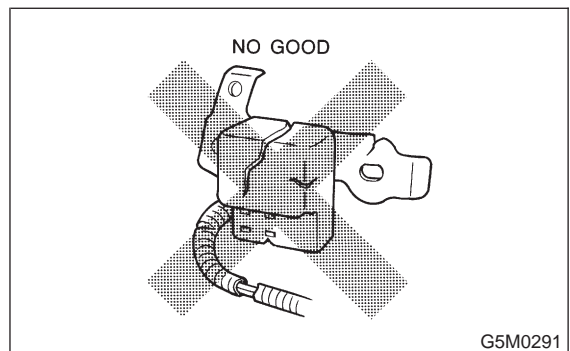

- When painting or performing sheet metal work on the front part of vehicle body, including the front wheel apron, front fender and front side frame, take utmost care not to apply dryer heat, painting mist, or the flame of the welding burner directly to the front sub sensors and wire harness of the airbag system.

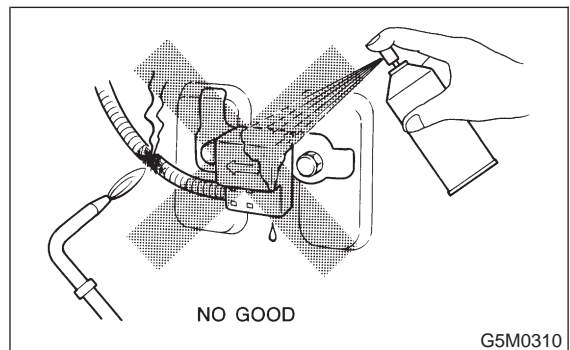

1. FRONT SUB SENSOR HARNESS

- 1) Turn ignition switch off.
- 2) Disconnect ground cable from battery and wait for at least 20 seconds before starting work.
- 3) Remove lower cover. <Ref. to 5-4 [W1A0].>

C: INSTALLATION

CAUTION:

Failure to do this might damage roll connector.

- 1) Before installing combination switch, check to ensure that combination switch is off and front wheels are set in the straight ahead position.
- 2) Install column cover and center roll connector.
- 3) Install steering wheel in neutral position. Carefully insert roll connector pin (A) into hole on steering wheel.

NOTE:

If steering wheel angle requires fine adjustment, adjust tie-rod. <Ref. to 4-3 [W3F0].> and <Ref. to 4-3 [W4F0].>

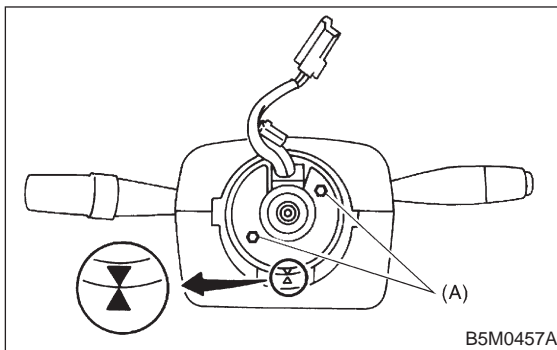

- 4) Install airbag module and lower cover in the reverse order of removal.

7. Front Sub Sensor

A: REMOVAL AND INSTALLATION

CAUTION:

- If the front end of the vehicle body is damaged by a collision, be sure to check the left and right front sub sensors, even if the airbag was not inflated. If any damage to the sensor or any deformation of the sensor mount is found, replace with a new genuine part.

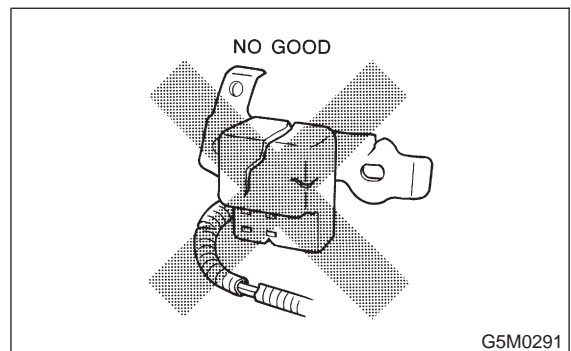

- When painting or performing sheet metal work on the front part of vehicle body, including the front wheel apron, front fender and front side frame, take utmost care not to apply dryer heat, painting mist, or the flame of the welding burner directly to the front sub sensors and wire harness of the airbag system.

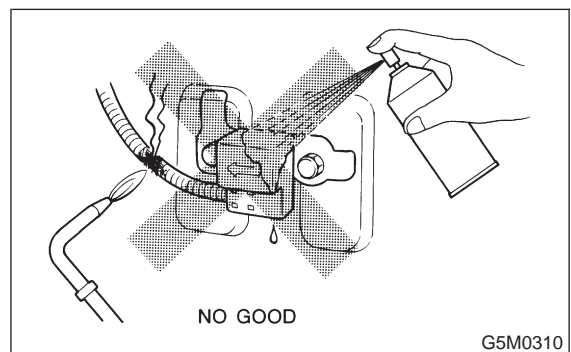

1. FRONT SUB SENSOR HARNESS

- 1) Turn ignition switch off.
- 2) Disconnect ground cable from battery and wait for at least 20 seconds before starting work.
- 3) Remove lower cover. <Ref. to 5-4 [W1A0].>

4) Disconnect airbag connector (AB3) and (AB8) below steering column.

CAUTION:
Do not reconnect airbag connector at steering column until front sub sensors are securely re-installed.

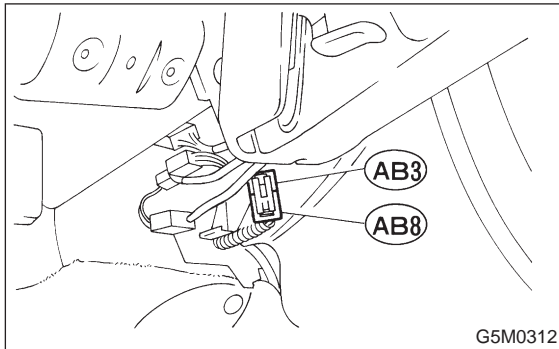

5) Remove front side sill cover and then disconnect front sub sensor connector. <Ref. to 5-5 [M2F2].>

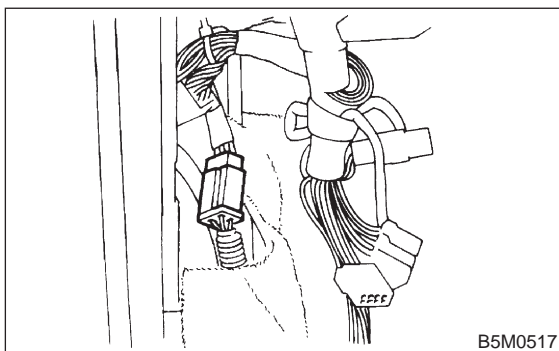

6) Remove front wheel and mud guard.
7) Disconnect connector from front sub sensor assembly. <Ref. to 5-5 [M2F3].>

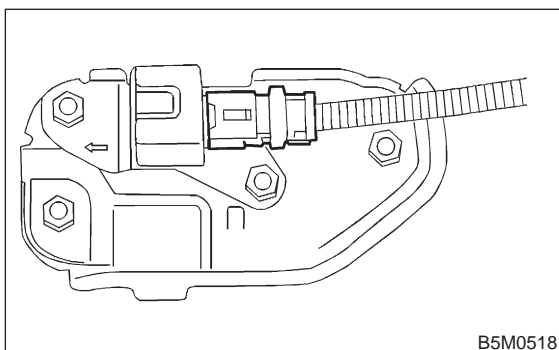

8) Remove wiring harness clips.

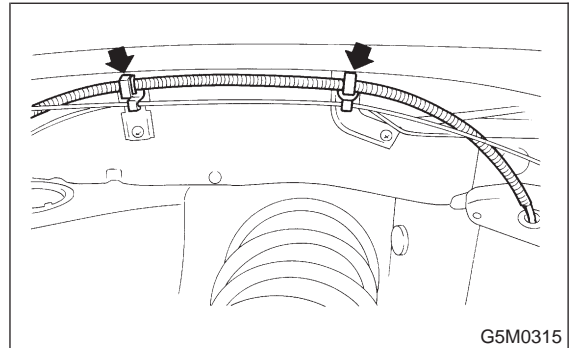

9) Remove grommet and then detach front sub sensor harness.

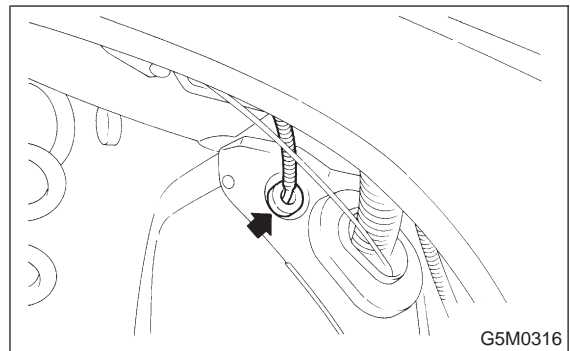

2. FRONT SUB SENSOR ASSEMBLY

- 1) Turn ignition switch off.
- 2) Disconnect ground cable from battery and wait for at least 20 seconds before starting work.
- 3) Remove front wheel and mud guard.
- 4) Disconnect connector from front sub sensor assembly. <Ref. to 5-5 [M2F3].>

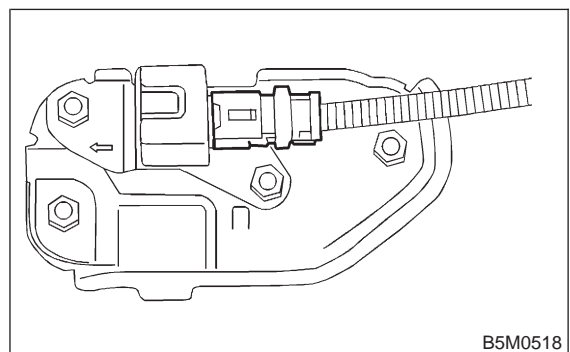

- 5) Remove front sub sensor.

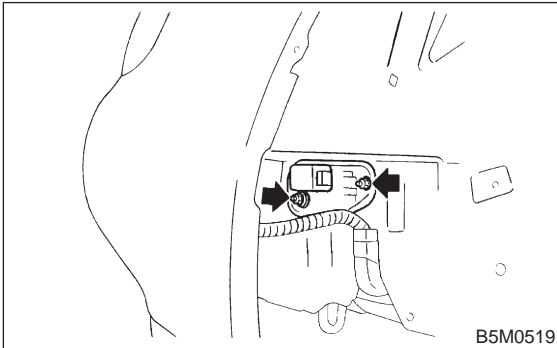

- 6) Installation is in the reverse order of removal.

8. Side Airbag Sensor

A: REMOVAL AND INSTALLATION

CAUTION:

● If the side of the vehicle body is damaged by a collision, be sure to check the left and right side airbag sensors, even if the airbag was not inflated. If any damage to the sensor or any deformation of the sensor mount is found, replace with a new genuine part.

● When painting or performing sheet metal work on the side part of vehicle body, including the side sill, center pillar, front and rear doors, take utmost care not to apply dryer heat, painting mist, or the flame of the welding burner directly to the side airbag sensors and wire harness of the airbag system.

- 1) Turn ignition switch off.
- 2) Disconnect ground cable from battery and wait for at least 20 seconds before starting work.
- 3) Remove center pillar lower. <Ref. to 5-3 [W5A2].>
- 4) Remove two TORX® bolts and then detach side airbag sensor while disconnecting connector. <Ref. to 5-5 [M2F3].>

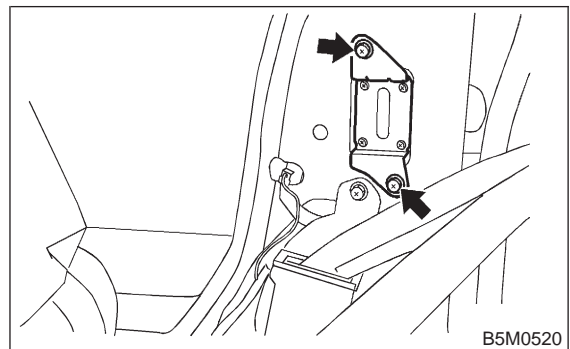

- 5) Installation is in the reverse order of removal.

- 5) Remove front sub sensor.

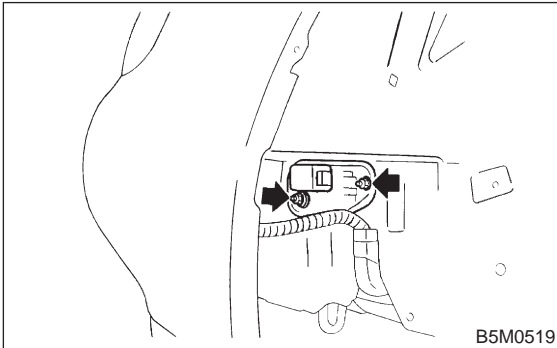

- 6) Installation is in the reverse order of removal.

8. Side Airbag Sensor

A: REMOVAL AND INSTALLATION

CAUTION:

- If the side of the vehicle body is damaged by a collision, be sure to check the left and right side airbag sensors, even if the airbag was not inflated. If any damage to the sensor or any deformation of the sensor mount is found, replace with a new genuine part.

- When painting or performing sheet metal work on the side part of vehicle body, including the side sill, center pillar, front and rear doors, take utmost care not to apply dryer heat, painting mist, or the flame of the welding burner directly to the side airbag sensors and wire harness of the airbag system.

- 1) Turn ignition switch off.
- 2) Disconnect ground cable from battery and wait for at least 20 seconds before starting work.
- 3) Remove center pillar lower. <Ref. to 5-3 [W5A2].>
- 4) Remove two TORX® bolts and then detach side airbag sensor while disconnecting connector. <Ref. to 5-5 [M2F3].>

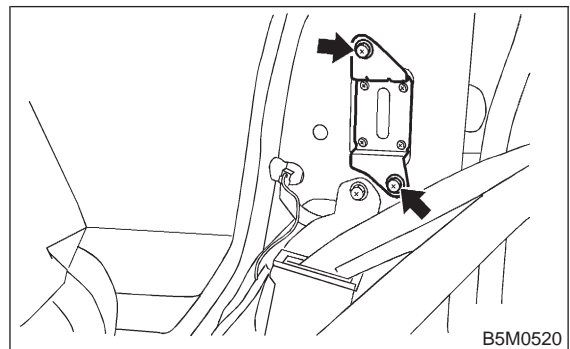

- 5) Installation is in the reverse order of removal.