

# Fuel Pump Relay

FUEL INJECTION (FUEL SYSTEMS)

## 20. Fuel Pump Relay

### A: REMOVAL

1) Disconnect the ground cable from battery.

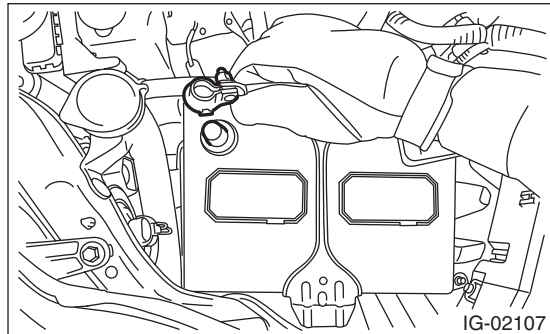

2) Remove the glove box lid assembly. <Ref. to EI-65, REMOVAL, Glove Box.>

3) Remove the fuel pump relay from the relay holder.

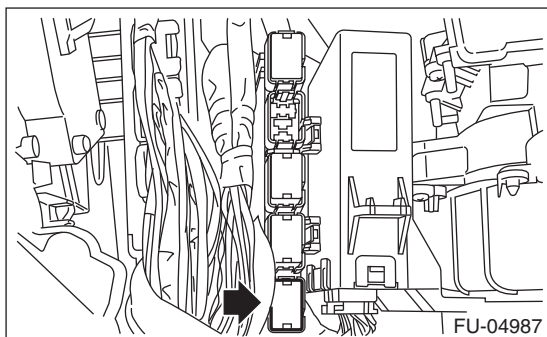

### B: INSTALLATION

Install in the reverse order of removal.

### C: INSPECTION

1) Check that the fuel pump relay has no deformation, cracks or other damages.

2) Measure the resistance between fuel pump relay terminals.

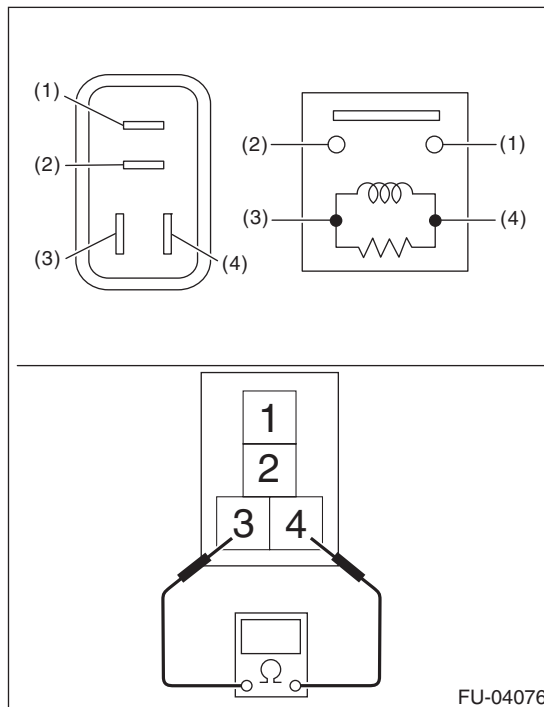

Terminal No.	Standard
1 and 2	1 M $\Omega$ or more
3 and 4	93.8 — 136.4 $\Omega$ (When 20°C (68°F))

# Fuel Pump Relay

3) Connect battery positive terminal to terminal No. 3 and battery ground terminal to terminal No. 4, and measure the resistance between the fuel pump relay terminals.

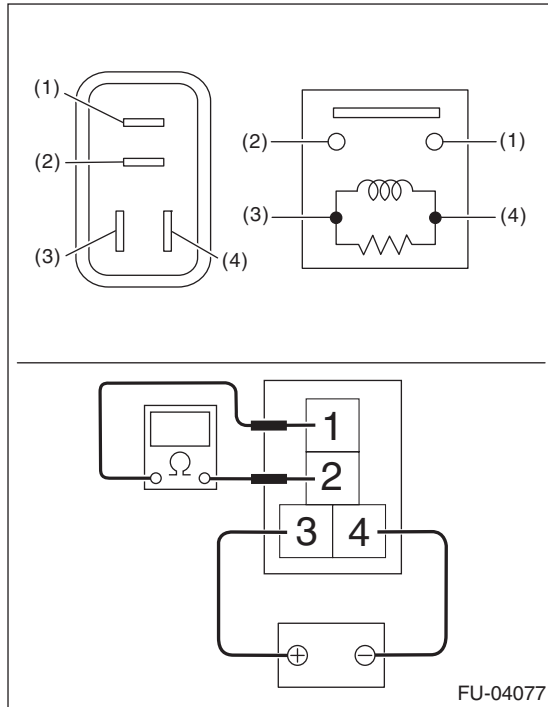

Terminal No.	Standard
1 and 2	Less than 1 $\Omega$