

24. Fuel Tank

A: REMOVAL

WARNING:

Place "NO OPEN FLAMES" signs near the working area.

CAUTION:

Be careful not to spill fuel.

1) Release the fuel pressure. <Ref. to FU(H4DOTC)-65, RELEASING OF FUEL PRESSURE, PROCEDURE, Fuel.>

2) Drain fuel. <Ref. to FU(H4DOTC)-65, DRAINING FUEL (WITH SUBARU SELECT MONITOR), PROCEDURE, Fuel.>

3) Disconnect the ground cable from battery.

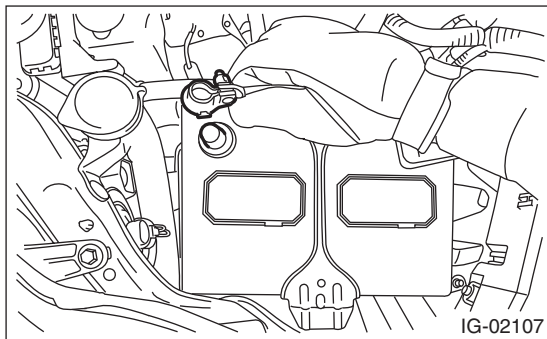

4) Remove the rear seat cushion. <Ref. to SE-32, REMOVAL, Rear Seat.>

5) Remove the clips (A) and seat cushion hooks (B), and turn over the floor mat (C).

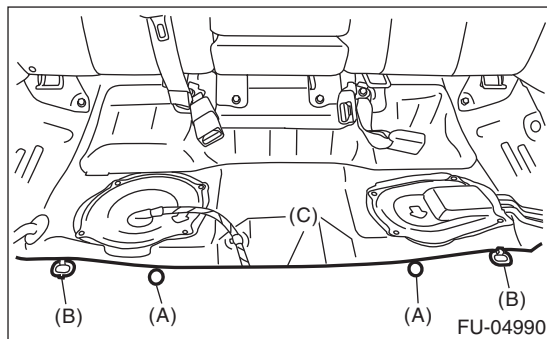

6) Remove the service hole cover of fuel pump.

(1) Disconnect the fuel cord connector (A), and remove the clip (B).

(2) Remove the screw (C).

(3) Push the grommet (D) down and remove the service hole cover.

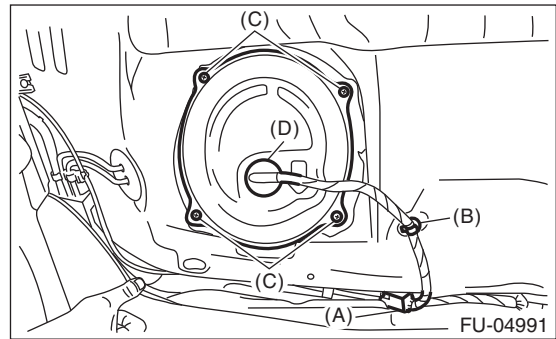

7) Remove the service hole cover of fuel sub level sensor.

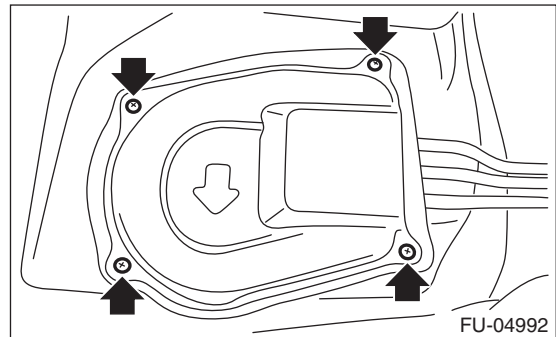

8) Disconnect the quick connector of fuel delivery tube (A) and fuel return tube (B). <Ref. to FU(H4DOTC)-87, REMOVAL, Fuel Delivery, Return and Evaporation Lines.>

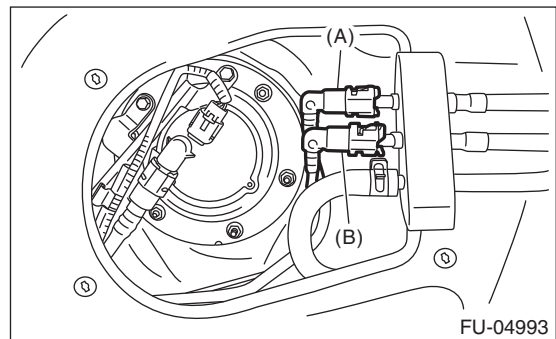

9) Remove the rear wheels.

10) Lift up the vehicle.

11) Remove the rear ABS wheel speed sensor from the rear housing.

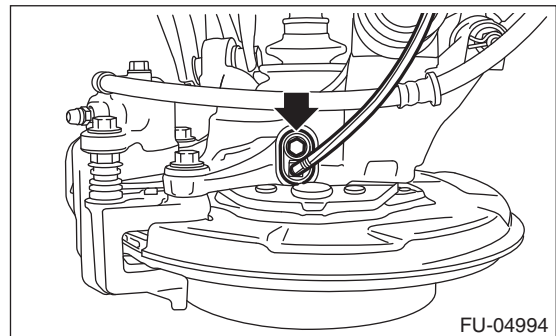

Fuel Tank

FUEL INJECTION (FUEL SYSTEMS)

12) Remove the rear ABS wheel speed sensor harness bracket from the upper arm.

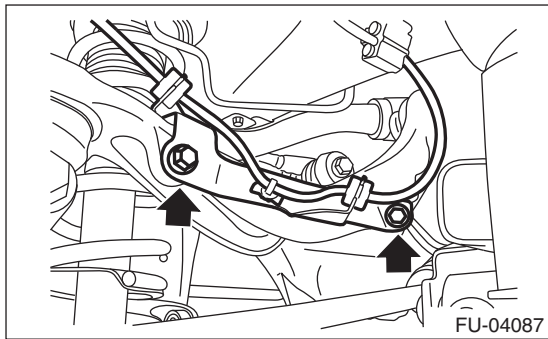

13) Remove the rear brake hose bracket from rear housing.

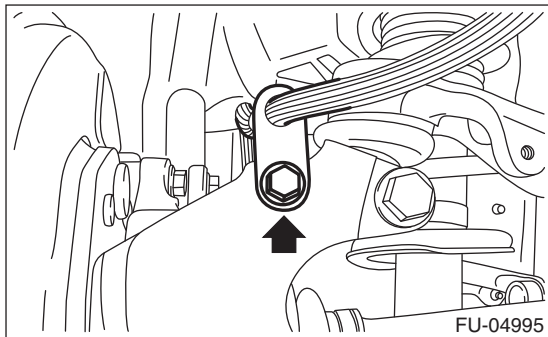

14) Remove the rear disc brake assembly and tie it to the body side of the vehicle.

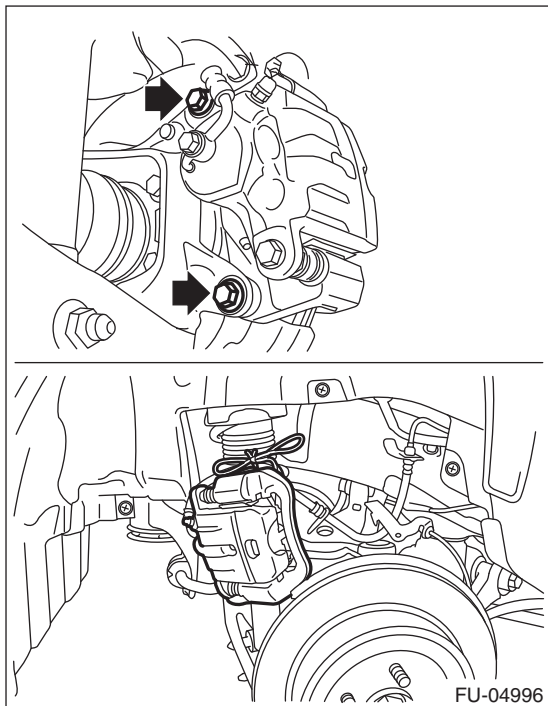

15) Remove the parking brake cable from parking brake assembly. <Ref. to PB-6, REMOVAL, Parking Brake Assembly (Rear Disc Brake).>

16) Remove the rear exhaust pipe and muffler. <Ref. to EX(H4DOTC)-15, REMOVAL, Rear Exhaust Pipe.> <Ref. to EX(H4DOTC)-16, REMOVAL, Muffler.>

17) Remove the propeller shaft. <Ref. to DS-10, REMOVAL, Propeller Shaft.>

18) Remove the clip (A) securing the fuel tank protector and heat shield cover.

19) Remove the bolts (B) and nuts (C) securing the fuel tank protector, and remove the fuel tank protector.

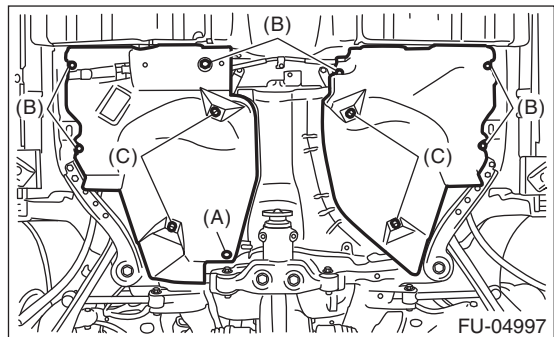

20) Remove the bolts and nuts securing the heat shield cover and remove the heat shield cover.

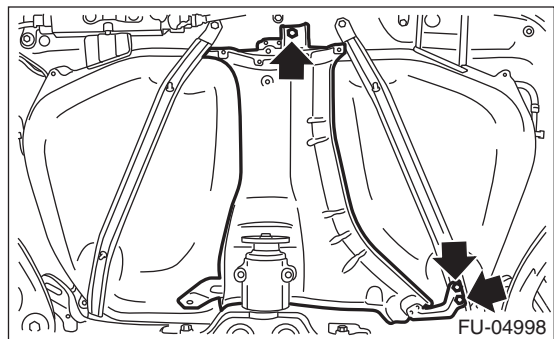

21) Remove the rear suspension assembly.

WARNING:

A helper is required to perform this work.

(1) Support the rear differential with the transmission jack.

(2) Remove the bolt and nut which secure rear shock absorber to rear suspension arm.

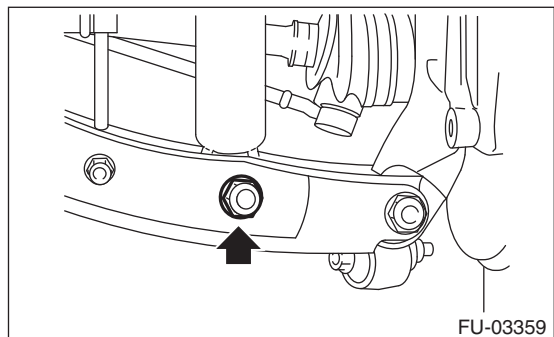

Fuel Tank

FUEL INJECTION (FUEL SYSTEMS)

(3) Remove the bolts which secure the rear suspension assembly to the body.

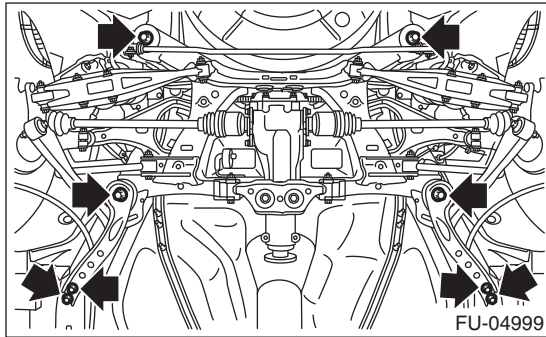

(4) Remove the rear suspension assembly.

22) Disconnect the PCV drain hose (A) and PCV outlet hose (B) from the pressure control solenoid valve.

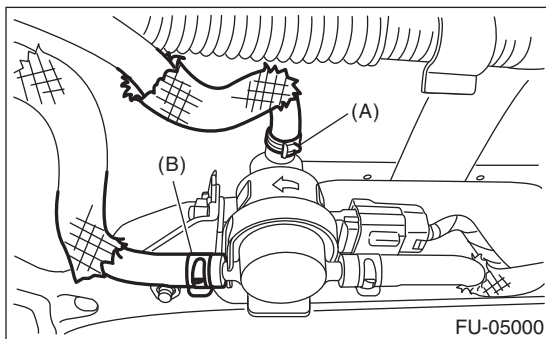

23) Disconnect the air vent hose from the fuel tank.

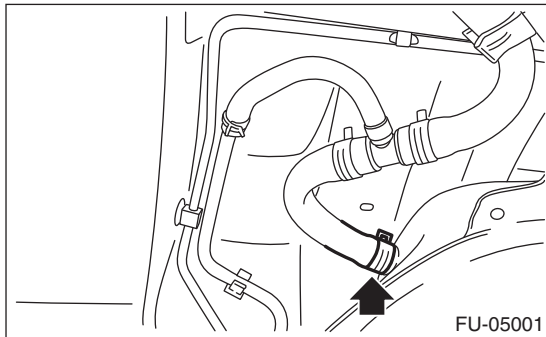

24) Disconnect the quick connector of the circulate tube from evaporation pipe.

NOTE:

Disconnect the quick connector as shown in the figure.

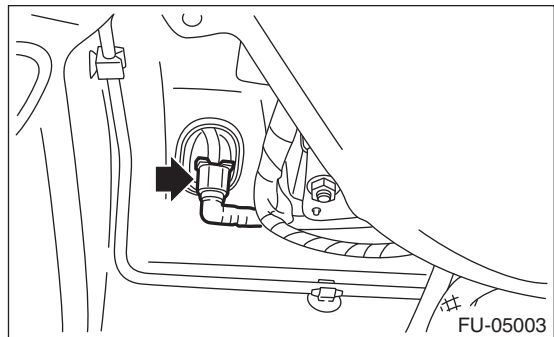
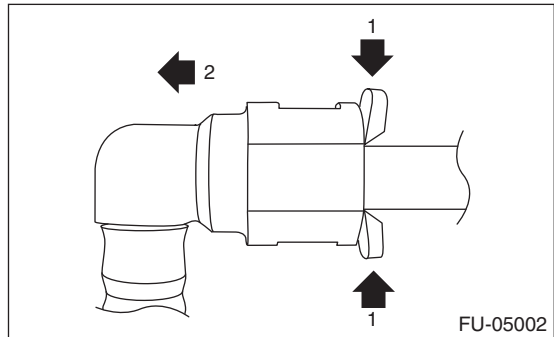

25) Disconnect the fuel filler hose (A), PCV inlet hose (B) and circulate hose (C) from the fuel filler pipe assembly.

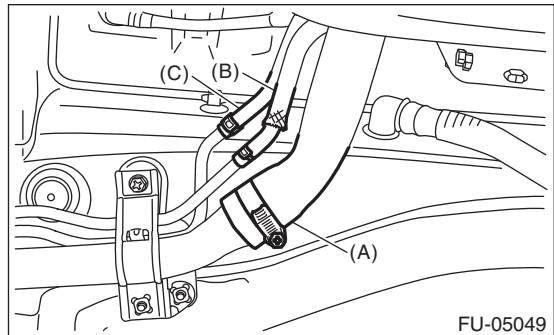

26) Support the fuel tank with a transmission jack, remove the bolts from the fuel tank band, and remove the fuel tank from the vehicle.

WARNING:

- A helper is required to perform this work.

Fuel Tank

FUEL INJECTION (FUEL SYSTEMS)

- Fuel may remain in the fuel tank. This will cause the left and right sides to be unbalanced. Be careful not to drop the fuel tank when removing.

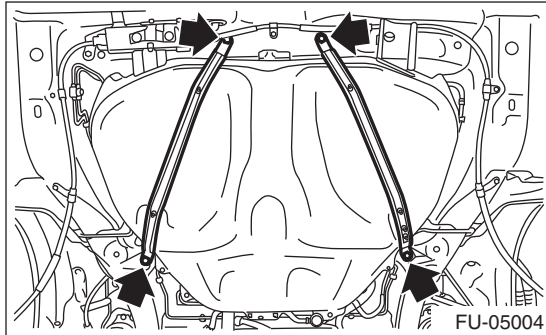

B: INSTALLATION

1) Support the fuel tank with a transmission jack, set the fuel tank in place, and temporarily tighten the bolts of the fuel tank band.

WARNING:

A helper is required to perform this work.

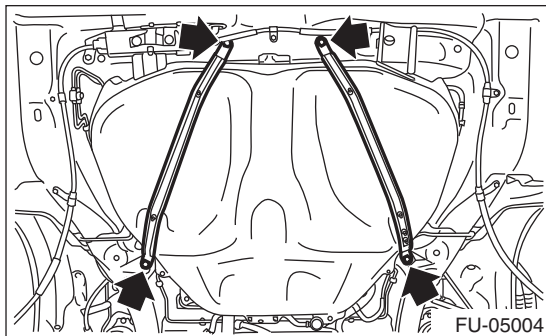

2) Securely insert the fuel filler hose (A), PCV inlet hose (B) and circulate hose (C) to the spool or stopper, then attach the clamp or clip as shown in the figure.

Tightening torque:

2.5 N·m (0.3 kgf·m, 1.8 ft·lb)

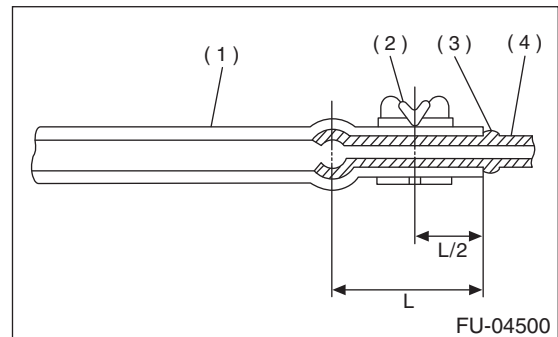
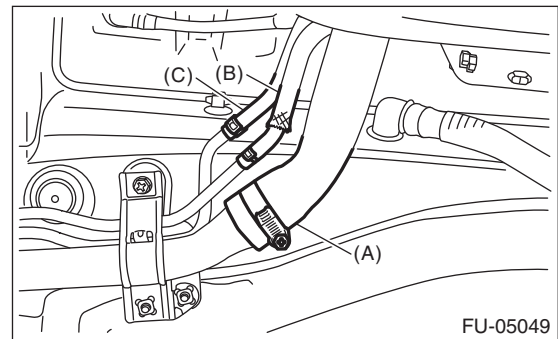

- (1) Hose
- (2) Clamp or clip
- (3) Spool or stopper
- (4) Pipe

3) Connect the quick connector of the circulate tube to the evaporation pipe as shown in the figure.

CAUTION:

- Check that there is no damage or dust on the quick connector. If necessary, clean the seal surface of the pipe.

Fuel Tank

FUEL INJECTION (FUEL SYSTEMS)

- Make sure that the quick connector is securely connected.

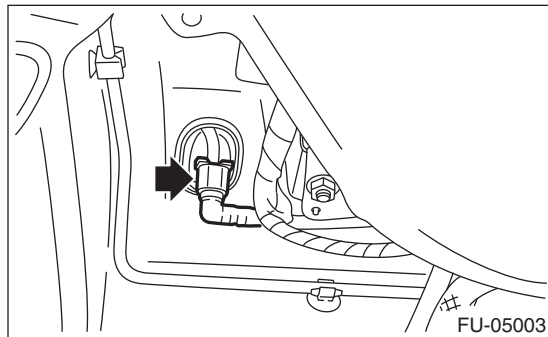
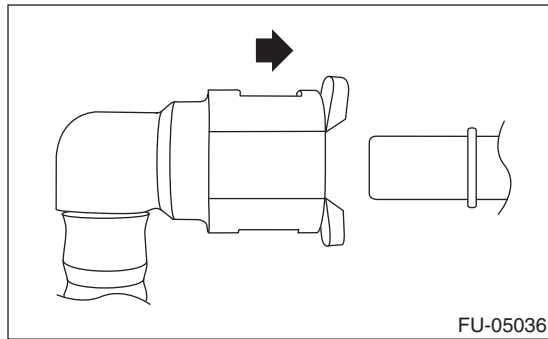

- 4) Connect the air vent hose to fuel tank.

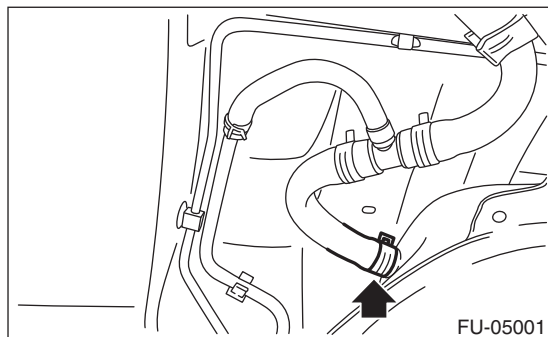

- 5) Connect the PCV drain hose (A) and PCV outlet hose (B) to the pressure control solenoid valve.

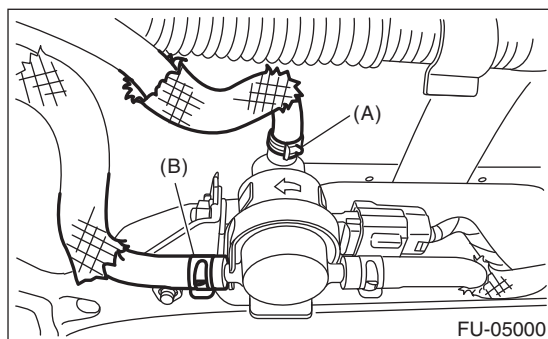

- 6) Tighten the bolts of the fuel tank band in the order shown in the figure.

Tightening torque:
33 N·m (3.4 kgf-m, 24.3 ft-lb)

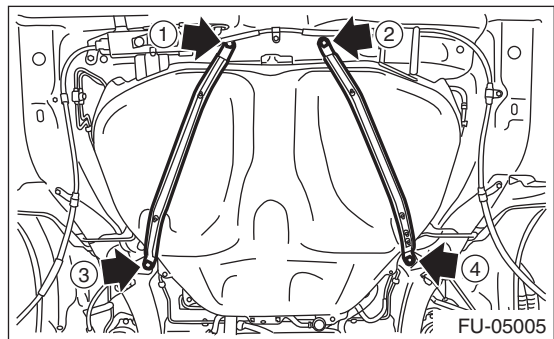

- 7) Install the rear suspension assembly.

WARNING:

A helper is required to perform this work.

(1) Support the rear differential with the transmission jack.

(2) While supporting the rear suspension assembly, install the rear suspension assembly to the body.

Tightening torque:

T1: 70 N·m (7.1 kgf-m, 51.6 ft-lb)

T2: 200 N·m (20.4 kgf-m, 147.5 ft-lb)

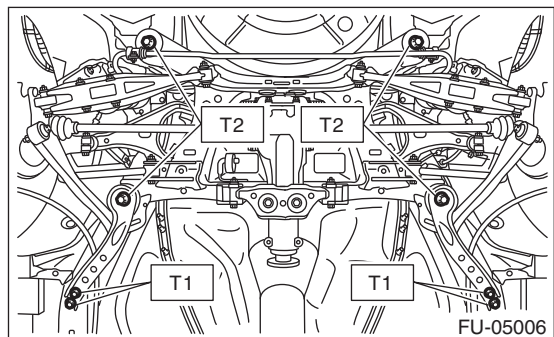

- (3) Install the rear shock absorber to the rear suspension arm.

NOTE:

Use a new self-locking nut.

Tightening torque:

120 N·m (12.2 kgf-m, 88.5 ft-lb)

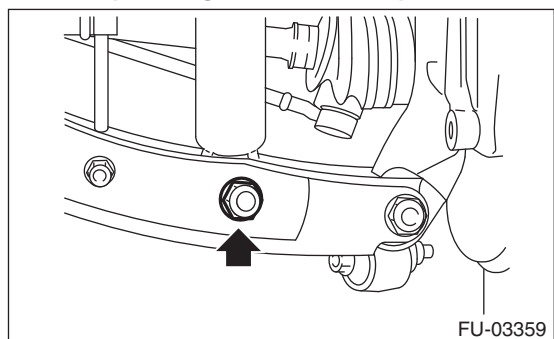

- 8) Install the heat shield cover.

Fuel Tank

FUEL INJECTION (FUEL SYSTEMS)

Tightening torque:

18 N-m (1.8 kgf-m, 13.3 ft-lb)

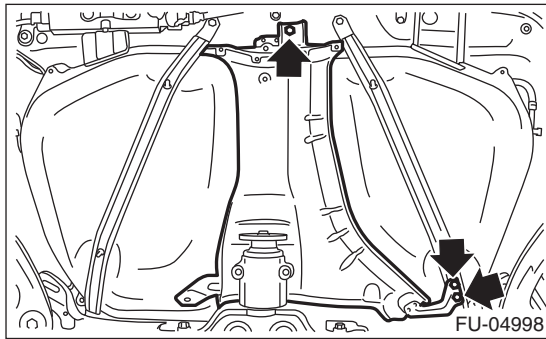

9) Install the bolts (B) and nuts (C) securing the fuel tank protector and install the clip (A) securing the fuel tank protector and heat shield cover.

Tightening torque:

Nut (C): 9 N-m (0.9 kgf-m, 6.6 ft-lb)

Bolt (B): 18 N-m (1.8 kgf-m, 13.3 ft-lb)

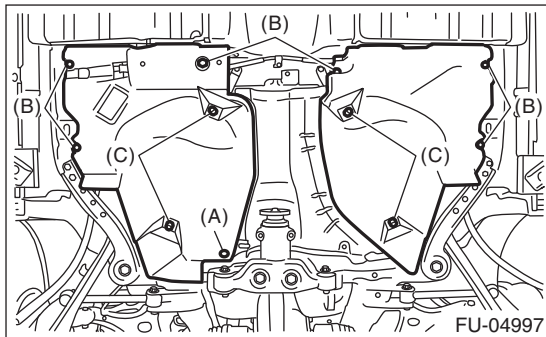

10) Install the propeller shaft. <Ref. to DS-10, INSTALLATION, Propeller Shaft.>

11) Install the rear exhaust pipe and muffler. <Ref. to EX(H4DOTC)-15, INSTALLATION, Rear Exhaust Pipe.> <Ref. to EX(H4DOTC)-16, INSTALLATION, Muffler.>

12) Lower the vehicle.

13) Connect the parking brake cable to the parking brake assembly. <Ref. to PB-7, INSTALLATION, Parking Brake Assembly (Rear Disc Brake).>

14) Install the rear disc brake assembly.

Tightening torque:

66 N-m (6.7 kgf-m, 48.7 ft-lb)

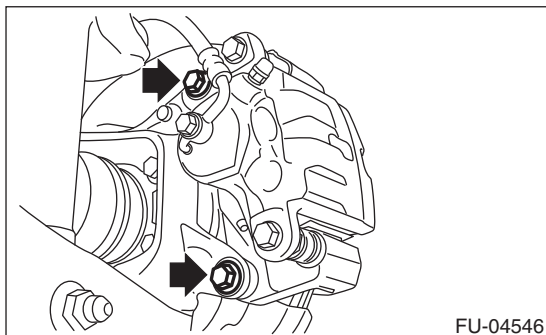

15) Install the rear brake hose bracket to the rear housing.

Tightening torque:

33 N-m (3.4 kgf-m, 24.3 ft-lb)

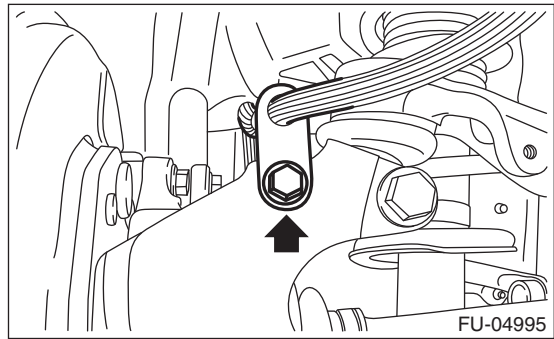

16) Install the rear ABS wheel speed sensor harness bracket to the upper arm.

Tightening torque:

7.5 N-m (0.8 kgf-m, 5.5 ft-lb)

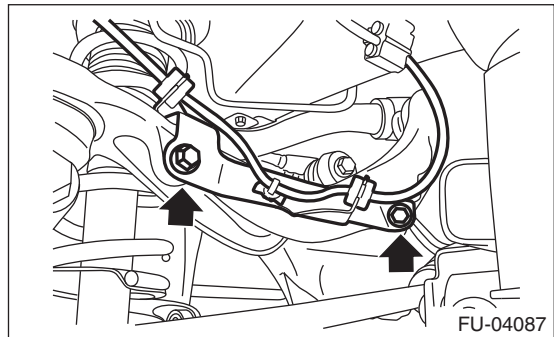

17) Install the rear ABS wheel speed sensor to the rear housing.

Tightening torque:

7.5 N-m (0.8 kgf-m, 5.5 ft-lb)

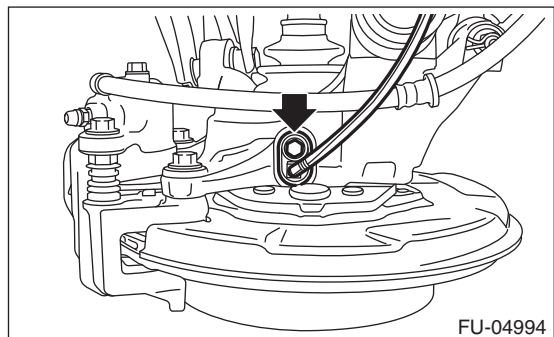

18) Install the rear wheels.

Tightening torque:

120 N-m (12.2 kgf-m, 88.5 ft-lb)

19) Connect the quick connector of fuel delivery tube (A) and fuel return tube (B). <Ref. to FU(H4DOTC)-89, INSTALLATION, Fuel Delivery, Return and Evaporation Lines.>

Fuel Tank

FUEL INJECTION (FUEL SYSTEMS)

NOTE:

When connecting, be careful not to reverse the delivery side and return side.

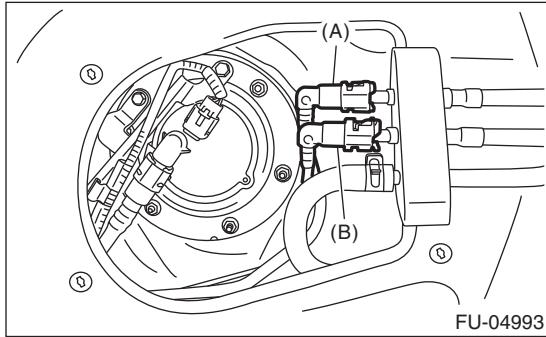

20) Install the service hole cover of fuel sub level sensor.

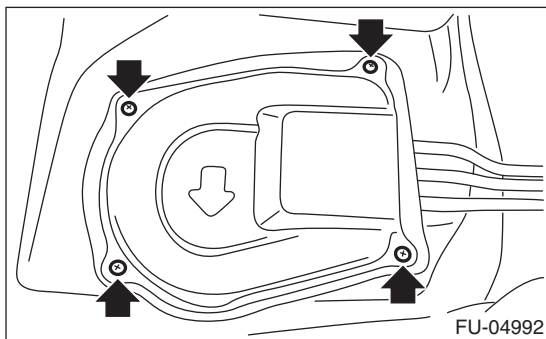

21) Install the service hole cover of the fuel pump, and install the connector and clip.

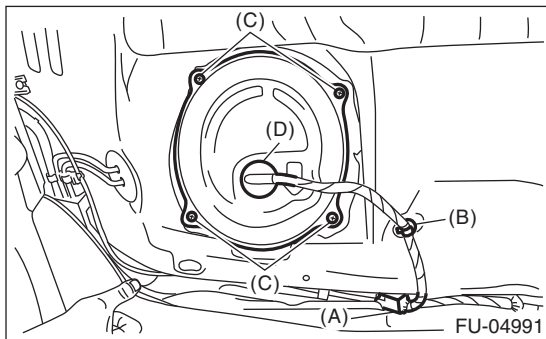

- (A) Connector
- (B) Clip
- (C) Screw
- (D) Grommet

22) Set the floor mat (C), and install clips (A) and seat cushion hooks (B).

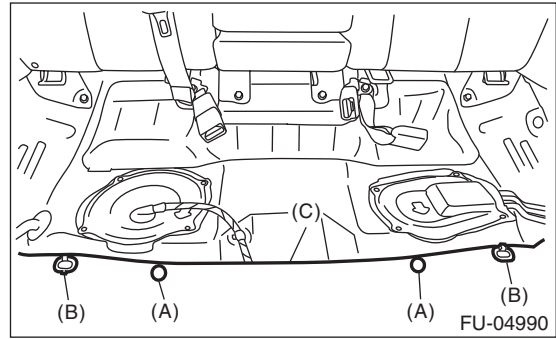

23) Install the rear seat cushion. <Ref. to SE-47, INSTALLATION, Rear Seat.>

24) Connect the ground cable to battery.

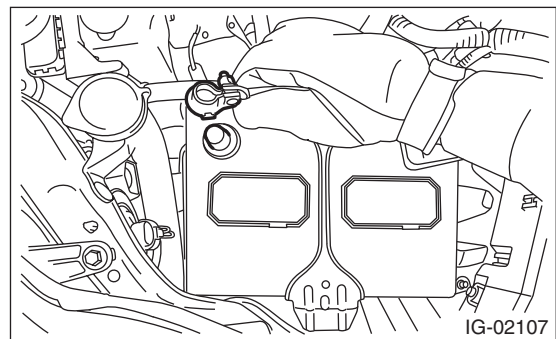

25) Inspect the wheel alignment and adjust if necessary.

C: INSPECTION

- 1) Check that the fuel tank and fuel pipe have no deformation, cracks and other damages.
- 2) Check that the fuel hose has no cracks, damage or loose part.