

Air Intake Boot

INTAKE (INDUCTION)

4. Air Intake Boot

A: REMOVAL

1) Disconnect the ground cable from battery.

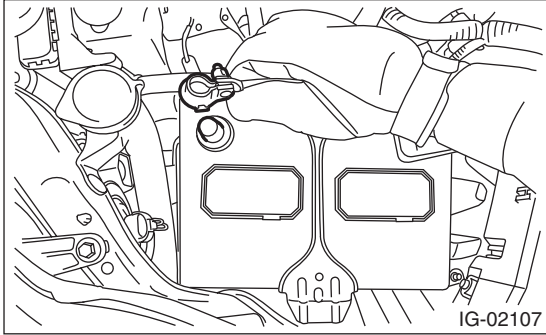

2) Remove the air intake duct. <Ref. to IN(H4DOTC)-12, REMOVAL, Air Intake Duct.>

3) Remove the air cleaner case. <Ref. to IN(H4DOTC)-8, REMOVAL, Air Cleaner Case.>

4) Lift up the vehicle.

5) Remove the under cover. <Ref. to EI-35, REMOVAL, Front Under Cover.>

6) Remove the intake duct from the air intake boot.

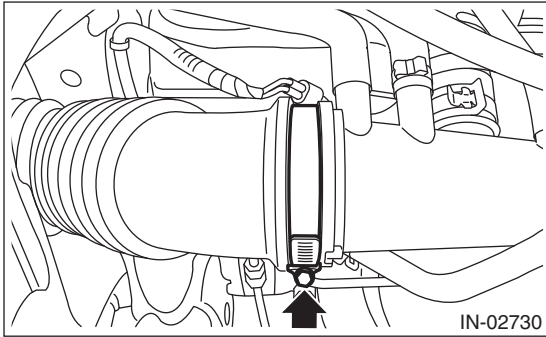

7) Lower the vehicle.

8) Remove the nuts which secure the air intake boot to the vehicle, and remove the air intake boot from the upper side of the vehicle.

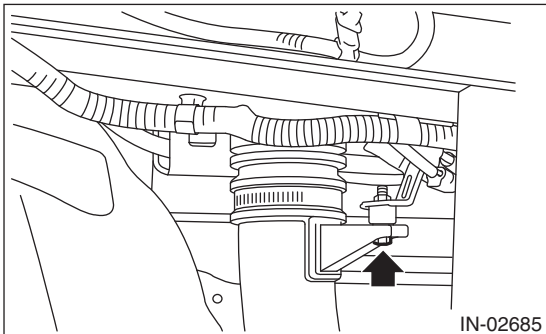

B: INSTALLATION

Install in the reverse order of removal.

NOTE:

When installing the air intake boot to the vehicle, pay attention to the mounting hole position, and align the protrusion for stopping rotation of cushion to the cutout portion on the turbo duct.

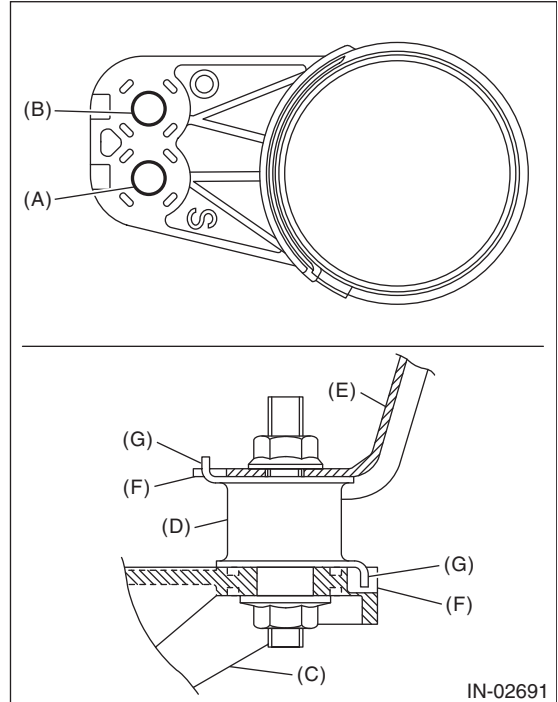

- (A) Attachment hole
- (B) Not used
- (C) Turbo duct
- (D) Cushion
- (E) Duct bracket
- (F) Cutout portion
- (G) Protrusion portion

Tightening torque:

7.5 N·m (0.8 kgf·m, 5.5 ft·lb)

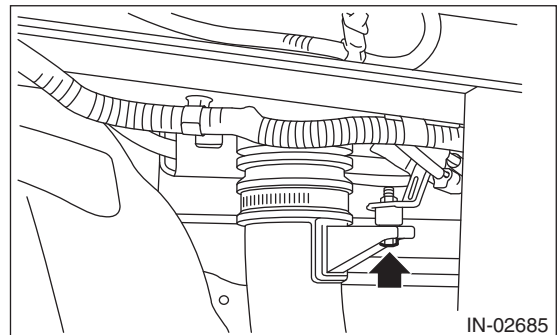

Tightening torque:

2.5 N·m (0.3 kgf·m, 1.8 ft·lb)

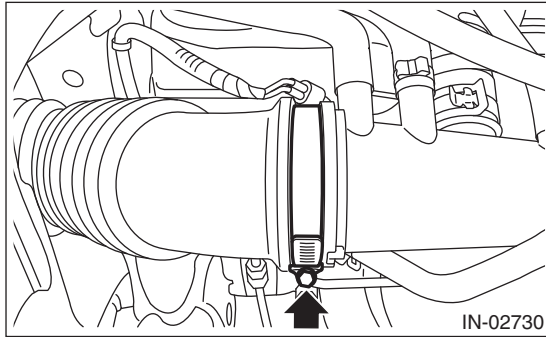

C: DISASSEMBLY

Remove the air intake boot from the turbo duct.

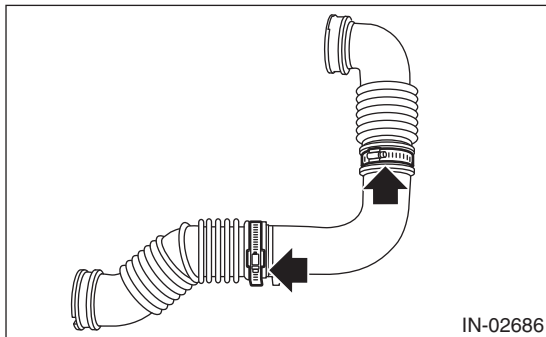

D: ASSEMBLY

Install the air intake boot to the turbo duct.

Tightening torque:

2.5 N·m (0.3 kgf·m, 1.8 ft·lb)

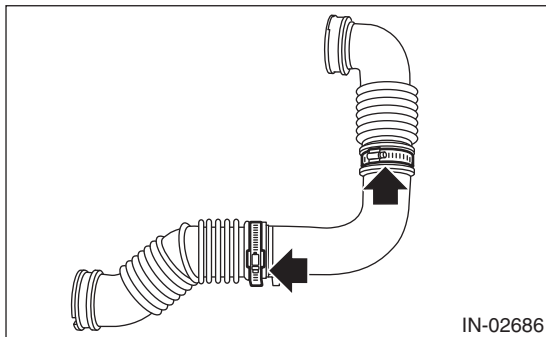

E: INSPECTION

Check that the air intake boot and turbo duct have no cracks, damage or loose part.