

## 9. Oil Catch Tank

### A: REMOVAL

- 1) Lift up the vehicle.
- 2) Remove the under cover. <Ref. to EI-35, REMOVAL, Front Under Cover.>
- 3) Remove the engine cover.

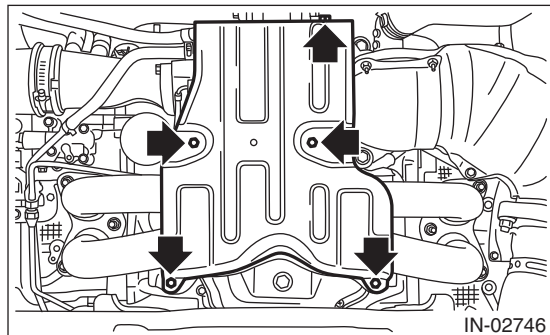

- 4) Disconnect vacuum hose (A) and oil outlet hose (B) from the oil catch tank.

#### NOTE:

Pinch the clamp of the vacuum hose (A) by fitting the cut out in the ST with the protrusion on the clamp as shown in the figure, and unlock the clamp.

ST 18353AA000 CLAMP PLIERS

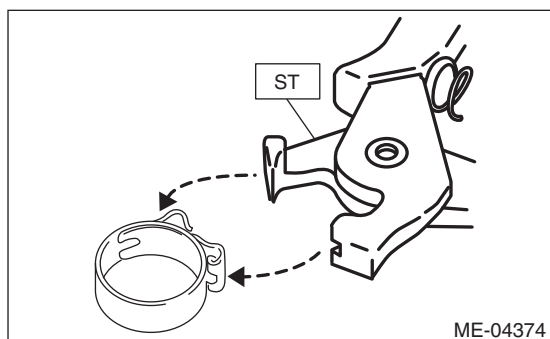

- 5) Remove bolts and nuts which secure the oil catch tank to the turbocharger and oil catch tank stay, and remove the oil catch tank.

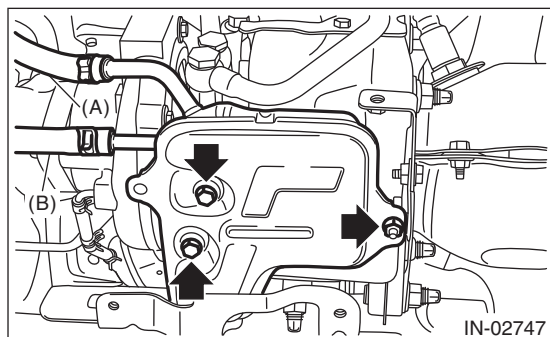

### B: INSTALLATION

Install in the reverse order of removal.

#### NOTE:

- Use a new gasket.
  - When installing the oil catch tank, tighten to the specified torque in the alphabetical order shown in the figure.
  - Use a new clamp for the vacuum hose, fit the cut out in the ST with the protrusion on the clamp as shown in the figure, and lock the clamp.
- ST 18353AA000 CLAMP PLIERS

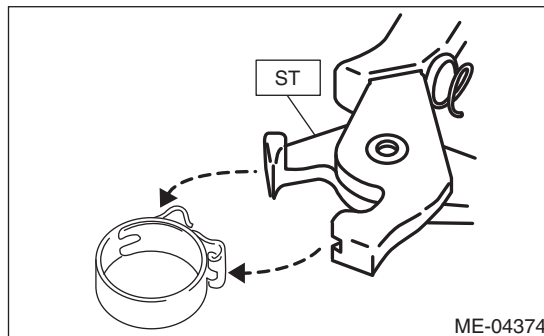

#### Tightening torque:

**T1: 6.4 N·m (0.7 kgf·m, 4.7 ft·lb)**

**T2: 10.5 N·m (1.1 kgf·m, 7.7 ft·lb)**

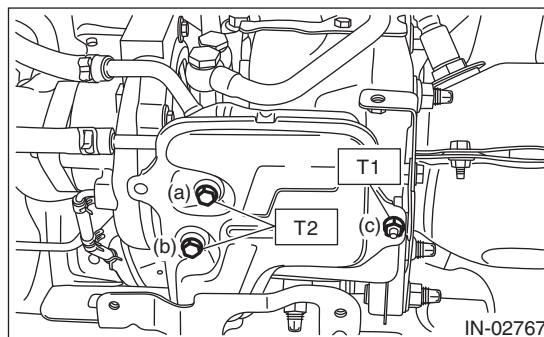

#### Tightening torque:

**6.4 N·m (0.7 kgf·m, 4.7 ft·lb)**

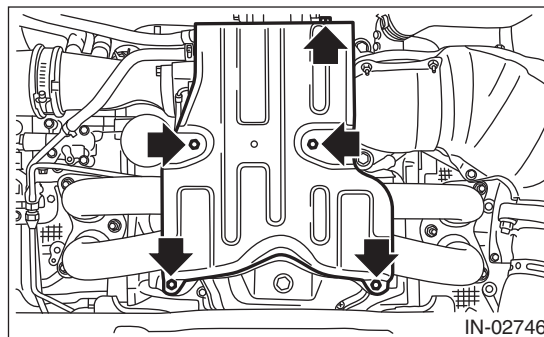

### C: INSPECTION

- 1) Check that the oil catch tank does not have deformation, cracks or damage.
- 2) Check that the vacuum hose and oil outlet hose have no cracks, damage or loose part.