

### 14. Diagnostic Procedure with Diagnostic Trouble Code (DTC)

#### A: DTC P0705 TRANSMISSION RANGE SENSOR CIRCUIT (PRNDL INPUT)

##### DTC DETECTING CONDITION:

The inhibitor switch is open or short.

##### TROUBLE SYMPTOM:

- Shift characteristics are erroneous.
- Shift indicator light does not match with select lever.
- Shift indicator light does not illuminate.
- N-D, N-R shock occur.

# Diagnostic Procedure with Diagnostic Trouble Code (DTC)

## AUTOMATIC TRANSMISSION (DIAGNOSTICS)

### WIRING DIAGRAM:

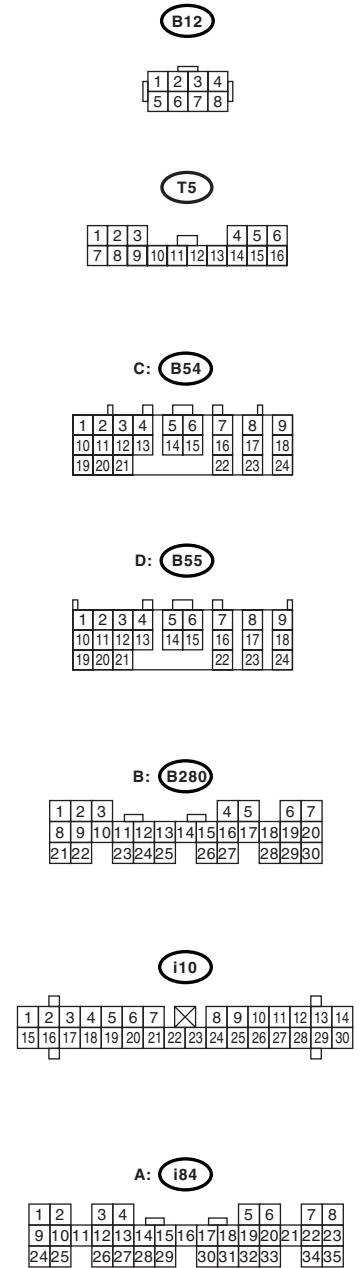
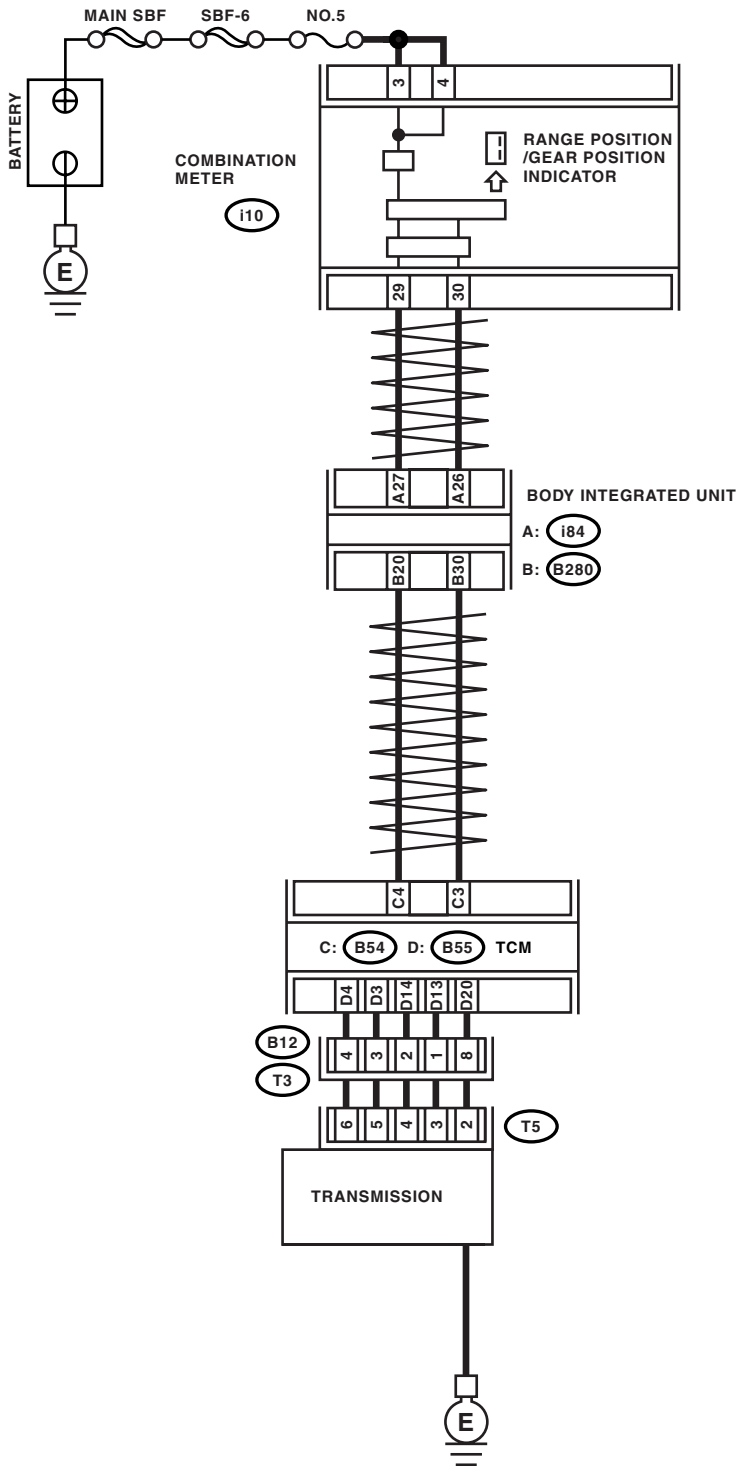

AT-03286

Step	Check	Yes	No
1	CHECK DTC OF TCM. Is DTC of AT CAN communication circuit displayed?	Perform the diagnosis according to DTC.	Go to step 2.

# Diagnostic Procedure with Diagnostic Trouble Code (DTC)

AUTOMATIC TRANSMISSION (DIAGNOSTICS)

Step	Check	Yes	No
<b>2 CHECK INHIBITOR SWITCH.</b> 1) Shift the select lever to shift to the "P" range. 2) Check input signal of inhibitor SW 1 — 4 and inhibitor SW 3 monitor using Subaru Select Monitor.	Are all indications High?	Go to step 4.	Go to step 3.
<b>3 CHECK HARNESS CONNECTOR BETWEEN TCM AND TRANSMISSION.</b> 1) Turn the ignition switch to OFF. 2) Disconnect the connectors from TCM and transmission. 3) Measure the resistance between TCM connector and chassis ground about the item which indicated Low on step 3. <b>Connector &amp; terminal</b> <b>(B55) No. 4 — Chassis ground:</b> <b>(B55) No. 3 — Chassis ground:</b> <b>(B55) No. 14 — Chassis ground:</b> <b>(B55) No. 13 — Chassis ground:</b> <b>(B55) No. 20 — Chassis ground:</b>	Is the resistance more than 1 MΩ?	Go to step 6.	Repair the short circuit of harness between TCM connector and chassis ground.
<b>4 CHECK INHIBITOR SWITCH.</b> 1) Shift the select lever to "D" range. 2) Check input signal of inhibitor SW 1 — 4 and inhibitor SW 3 monitor using Subaru Select Monitor.	Are all indications Low?	Go to step 6.	Go to step 5.
<b>5 CHECK HARNESS CONNECTOR BETWEEN TCM AND TRANSMISSION.</b> 1) Turn the ignition switch to OFF. 2) Disconnect the connectors from TCM and transmission. 3) Measure the resistance of harness between TCM and transmission connector about the item which indicated High on step 5. <b>Connector &amp; terminal</b> <b>(B55) No. 4 — (B12) No. 4:</b> <b>(B55) No. 3 — (B12) No. 3:</b> <b>(B55) No. 14 — (B12) No. 2:</b> <b>(B55) No. 13 — (B12) No. 1:</b> <b>(B55) No. 20 — (B12) No. 8:</b>	Is the resistance less than 1 Ω?	Go to step 6.	Repair the open circuit of harness between TCM connector and transmission connector.
<b>6 CHECK INPUT SIGNAL FOR TCM USING CIRCUIT TESTER.</b> 1) Turn the ignition switch to OFF. 2) Disconnect the transmission connector (B12). 3) Connect the TCM connector. 4) Turn the ignition switch to ON. 5) Measure the voltage between TCM terminals. <b>Connector &amp; terminal</b> <b>(B55) No. 4 — (B54) No. 19:</b> <b>(B55) No. 3 — (B54) No. 19:</b> <b>(B55) No. 14 — (B54) No. 19:</b> <b>(B55) No. 13 — (B54) No. 19:</b> <b>(B55) No. 20 — (B54) No. 19:</b>	Is the voltage 4 — 6 V for the inhibitor SW 1 — 4? Is the voltage 3.5 — 5.5 V for the inhibitor SW 3 monitor?	Go to step 8.	Go to step 7.

# Diagnostic Procedure with Diagnostic Trouble Code (DTC)

## AUTOMATIC TRANSMISSION (DIAGNOSTICS)

Step	Check	Yes	No
<b>7</b> <b>CHECK TCM I/O SIGNAL.</b> Check I/O signal of power supply, ground and PVIGN power supply relay. <Ref. to 5AT(diag)-11, ELECTRICAL SPECIFICATION, Transmission Control Module (TCM) I/O Signal.>	Is TCM I/O signal OK?	Replace the TCM. <Ref. to 5AT-56, Transmission Control Module (TCM).>	Repair the open or short circuit for power supply and ground. Perform the diagnosis according to DTC for PVIGN power supply relay.
<b>8</b> <b>CHECK HARNESS CONNECTOR BETWEEN TRANSMISSION AND CONTROL VALVE BODY.</b> 1) Turn the ignition switch to OFF. 2) Disconnect the connector from transmission. 3) Remove the transmission connector from bracket. 4) Lift-up the vehicle and place it on rigid racks. NOTE: Raise all wheels off floor. 5) Drain the ATF. <b>CAUTION:</b> <b>Do not drain ATF until it cools down.</b> 6) Remove the oil pan, and disconnect the connector from control valve body connector. 7) Measure the resistance between transmission connector and control valve body connector. <i>Connector &amp; terminal</i> <i>(T3) No. 4 — (T5) No. 6:</i> <i>(T3) No. 3 — (T5) No. 5:</i> <i>(T3) No. 2 — (T5) No. 4:</i> <i>(T3) No. 1 — (T5) No. 3:</i> <i>(T3) No. 8 — (T5) No. 2:</i>	Is the resistance less than 1 $\Omega$ ?	Go to step 9.	Repair the open circuit of harness between control valve body connector and transmission connector.
<b>9</b> <b>CHECK HARNESS CONNECTOR BETWEEN TRANSMISSION AND CONTROL VALVE BODY.</b> Measure the resistance between transmission ground and control valve body connector. <i>Connector &amp; terminal</i> <i>(T5) No. 6 — Transmission ground:</i> <i>(T5) No. 5 — Transmission ground:</i> <i>(T5) No. 4 — Transmission ground:</i> <i>(T5) No. 3 — Transmission ground:</i> <i>(T5) No. 2 — Transmission ground:</i>	Is the resistance more than 1 $M\Omega$ ?	Go to step 10.	Repair the short circuit of harness between control valve body connector and transmission connector.
<b>10</b> <b>CHECK POOR CONTACT.</b>	Is there any poor contact in inhibitor SW 1 — 4 or inhibitor SW 3 monitor circuit?	Repair the poor contact.	Replace the control valve body. <Ref. to 5AT-53, Control Valve Body.>

# Diagnostic Procedure with Diagnostic Trouble Code (DTC)

AUTOMATIC TRANSMISSION (DIAGNOSTICS)

## B: DTC P0712 TRANSMISSION FLUID TEMPERATURE SENSOR CIRCUIT LOW INPUT

### DTC DETECTING CONDITION:

Input signal circuit to ATF temperature sensor 1 is open.

### TROUBLE SYMPTOM:

Excessive shift shock

### WIRING DIAGRAM:

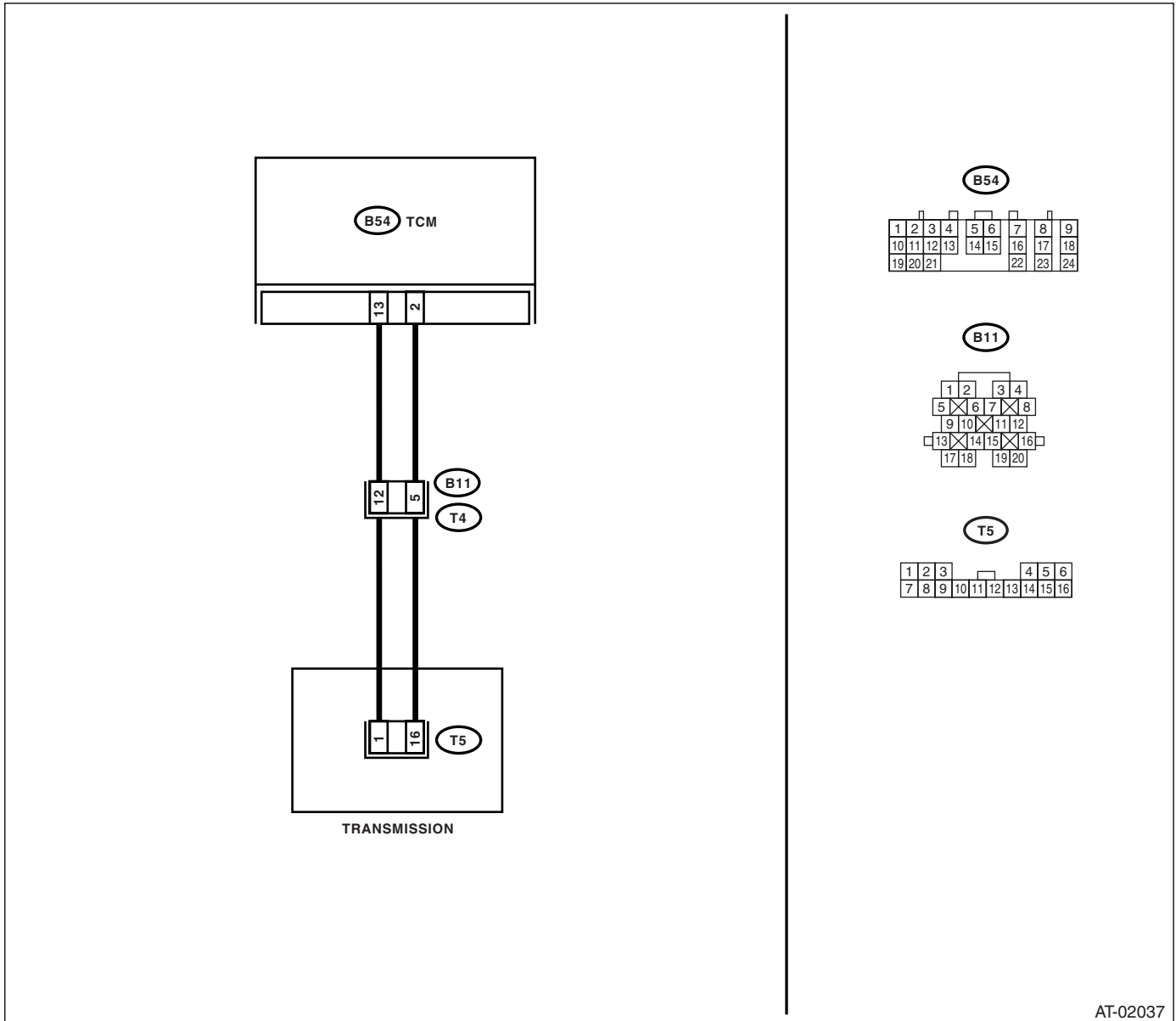

AT-02037

# Diagnostic Procedure with Diagnostic Trouble Code (DTC)

## AUTOMATIC TRANSMISSION (DIAGNOSTICS)

Step	Check	Yes	No
<b>1 CHECK HARNESS CONNECTOR BETWEEN TCM AND TRANSMISSION.</b> 1) Turn the ignition switch to OFF. 2) Disconnect the connectors from TCM and transmission. 3) Measure the resistance of harness between TCM and transmission connector. <b>Connector &amp; terminal</b> <b>(B54) No. 13 — (B11) No. 12:</b> <b>(B54) No. 2 — (B11) No. 5:</b>	Is the resistance less than 1 $\Omega$ ?	Go to step 2.	Repair the open circuit of harness between TCM and transmission connector.
<b>2 CHECK ATF TEMPERATURE SENSOR.</b> 1) Turn the ignition switch to OFF. 2) Connect the connectors to transmission and TCM. 3) Turn the ignition switch to ON and start engine. 4) Warm-up the transmission until the ATF temperature reaches to 80°C (176°F). NOTE: If the ambient temperature is below 0°C (32°F), drive the vehicle until the ATF reaches its operating temperature. 5) Disconnect the connector from transmission. 6) Measure the resistance between transmission connector terminals. <b>Connector &amp; terminal</b> <b>(T4) No. 5 — (T4) No.12:</b>	Is the resistance between 500 — 1,200 $\Omega$ ?	Go to step 3.	Go to step 5.
<b>3 CHECK ATF TEMPERATURE SENSOR.</b> Measure the resistance between transmission connector terminals. <b>Connector &amp; terminal</b> <b>(T4) No. 5 — (T4) No.12:</b>	Does the resistance value increase while the ATF temperature decreases?	Go to step 4.	Go to step 5.
<b>4 CHECK INPUT SIGNAL FOR TCM USING SUBARU SELECT MONITOR.</b> 1) Connect the connector. 2) Turn the ignition switch to ON. (Engine OFF) 3) Read the ATF temperature using Subaru Select Monitor.	Does the ATF temperature gradually decrease?	Even if the SPORT indicator light blinks, the system is in normal condition. A temporary poor contact of connector or harness may be the cause. Repair the poor contact of harness between ATF temperature sensor and transmission connector.	Go to step 6.

# Diagnostic Procedure with Diagnostic Trouble Code (DTC)

AUTOMATIC TRANSMISSION (DIAGNOSTICS)

Step	Check	Yes	No
<p><b>5</b>    <b>CHECK HARNESS CONNECTOR BETWEEN TRANSMISSION AND CONTROL VALVE BODY.</b></p> <p>1) Turn the ignition switch to OFF.                  2) Disconnect the connector from transmission.                  3) Remove the transmission connector from bracket.                  4) Lift-up the vehicle and place it on rigid racks.</p> <p>NOTE:                  Raise all wheels off floor.                  5) Drain the ATF.</p> <p><b>CAUTION:</b>  <b>Do not drain ATF until it cools down.</b></p> <p>6) Remove the oil pan, and disconnect the connector from control valve body connector.                  7) Measure the resistance between transmission connector and control valve body connector.</p> <p><i>Connector &amp; terminal</i>  <i>(T4) No. 12 — (T5) No. 1:</i>  <i>(T4) No. 5 — (T5) No. 16:</i></p>	<p>Is the resistance less than 1 <math>\Omega</math>?</p>	<p>Replace the control valve body.                  &lt;Ref. to 5AT-53, Control Valve Body.&gt;</p>	<p>Repair the open circuit of harness between transmission connector and control valve body connector.</p>
<p><b>6</b>    <b>CHECK POOR CONTACT.</b></p>	<p>Is there poor contact in ATF temperature sensor 1 circuit?</p>	<p>Repair the poor contact.</p>	<p>Replace the TCM.                  &lt;Ref. to 5AT-56, Transmission Control Module (TCM).&gt;</p>

# Diagnostic Procedure with Diagnostic Trouble Code (DTC)

AUTOMATIC TRANSMISSION (DIAGNOSTICS)

## C: DTC P0713 TRANSMISSION FLUID TEMPERATURE SENSOR CIRCUIT HIGH INPUT

### DTC DETECTING CONDITION:

Input signal circuit to ATF temperature sensor 1 is shorted.

### TROUBLE SYMPTOM:

Excessive shift shock

### WIRING DIAGRAM:

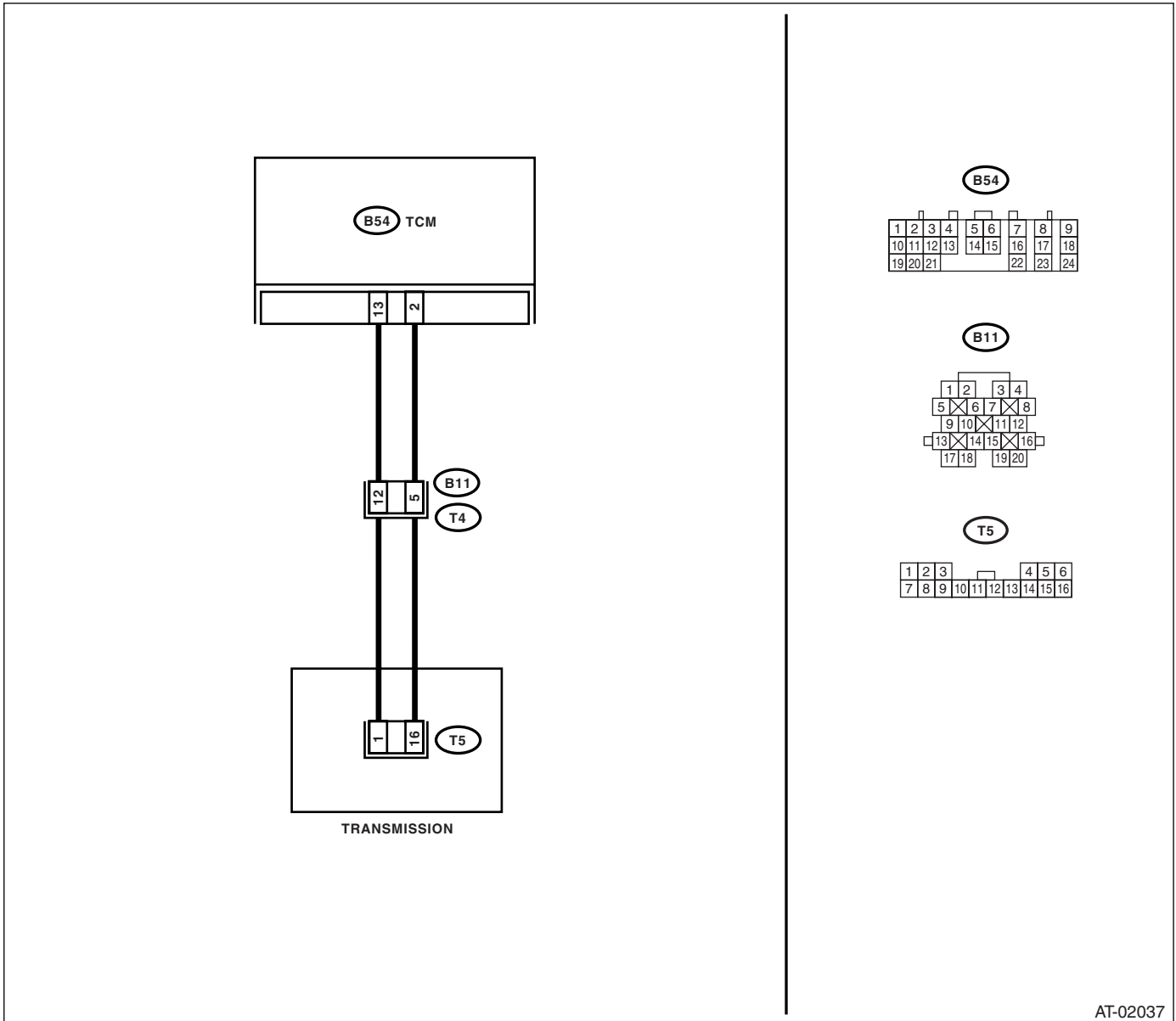

AT-02037



# Diagnostic Procedure with Diagnostic Trouble Code (DTC)

## AUTOMATIC TRANSMISSION (DIAGNOSTICS)

Step	Check	Yes	No
<b>1 CHECK HARNESS CONNECTOR BETWEEN TCM AND TRANSMISSION.</b> 1) Turn the ignition switch to OFF. 2) Disconnect the connectors from TCM and transmission. 3) Measure the resistance of harness between TCM connector and chassis ground. <b>Connector &amp; terminal</b> <b>(B54) No. 13 — Chassis ground:</b> <b>(B54) No. 2 — Chassis ground:</b>	Is the resistance more than 1 M $\Omega$ ?	Go to step 2.	Repair the short circuit of harness between TCM and transmission connector.
<b>2 CHECK ATF TEMPERATURE SENSOR.</b> 1) Turn the ignition switch to OFF. 2) Connect the connectors to transmission and TCM. 3) Turn the ignition switch to ON and start engine. 4) Warm-up the transmission until the ATF temperature reaches to 80°C (176°F). <b>NOTE:</b> If the ambient temperature is below 0°C (32°F), drive the vehicle until the ATF reaches its operating temperature. 5) Disconnect the connector from transmission. 6) Measure the resistance between transmission connector terminals. <b>Connector &amp; terminal</b> <b>(T4) No. 5 — (T4) No.12:</b>	Is the resistance between 500 — 1,200 $\Omega$ ?	Go to step 3.	Go to step 5.
<b>3 CHECK ATF TEMPERATURE SENSOR.</b> Measure the resistance between transmission connector terminals. <b>Connector &amp; terminal</b> <b>(T4) No. 5 — (T4) No.12:</b>	Does the resistance value increase while the ATF temperature decreases?	Go to step 4.	Go to step 5.
<b>4 CHECK INPUT SIGNAL FOR TCM USING SUBARU SELECT MONITOR.</b> 1) Connect the connector. 2) Turn the ignition switch to ON. (Engine OFF) 3) Read the ATF temperature using Subaru Select Monitor.	Does the ATF temperature gradually decrease?	Even if the SPORT indicator light blinks, the system is in normal condition. A temporary poor contact of connector or harness may be the cause. Repair the poor contact of harness between ATF temperature sensor and transmission connector.	Go to step 6.

## Diagnostic Procedure with Diagnostic Trouble Code (DTC)

### AUTOMATIC TRANSMISSION (DIAGNOSTICS)

Step	Check	Yes	No
<p><b>5</b></p> <p><b>CHECK HARNESS CONNECTOR BETWEEN TRANSMISSION AND CONTROL VALVE BODY.</b></p> <p>1) Turn the ignition switch to OFF.                      2) Disconnect the connector from transmission.                      3) Remove the transmission connector from bracket.                      4) Lift-up the vehicle and place it on rigid racks.</p> <p>NOTE:                      Raise all wheels off floor.                      5) Drain the ATF.</p> <p><b>CAUTION:</b>  <b>Do not drain ATF until it cools down.</b></p> <p>6) Remove the oil pan, and disconnect the connector from control valve body connector.                      7) Measure the resistance between chassis ground and control valve body connector.</p> <p><b>Connector &amp; terminal</b>  <i>(T5) No. 1 — Chassis ground:</i>  <i>(T5) No. 16 — Chassis ground:</i></p>	<p>Is the resistance more than 1 MΩ?</p>	<p>Replace the control valve body.                      &lt;Ref. to 5AT-53, Control Valve Body.&gt;</p>	<p>Repair the short circuit of harness between transmission connector and control valve body connector.</p>
<p><b>6</b></p> <p><b>CHECK POOR CONTACT.</b></p>	<p>Is there poor contact in ATF temperature sensor 1 circuit?</p>	<p>Repair the poor contact.</p>	<p>Replace the TCM.                      &lt;Ref. to 5AT-56, Transmission Control Module (TCM).&gt;</p>

# Diagnostic Procedure with Diagnostic Trouble Code (DTC)

AUTOMATIC TRANSMISSION (DIAGNOSTICS)

## D: DTC P0715 INPUT/TURBINE SPEED SENSOR CIRCUIT

### DTC DETECTING CONDITION:

Input signal circuit of TCM is open or shorted.

### TROUBLE SYMPTOM:

- Excessive shift shock
- Does not shift to 5th

### WIRING DIAGRAM:

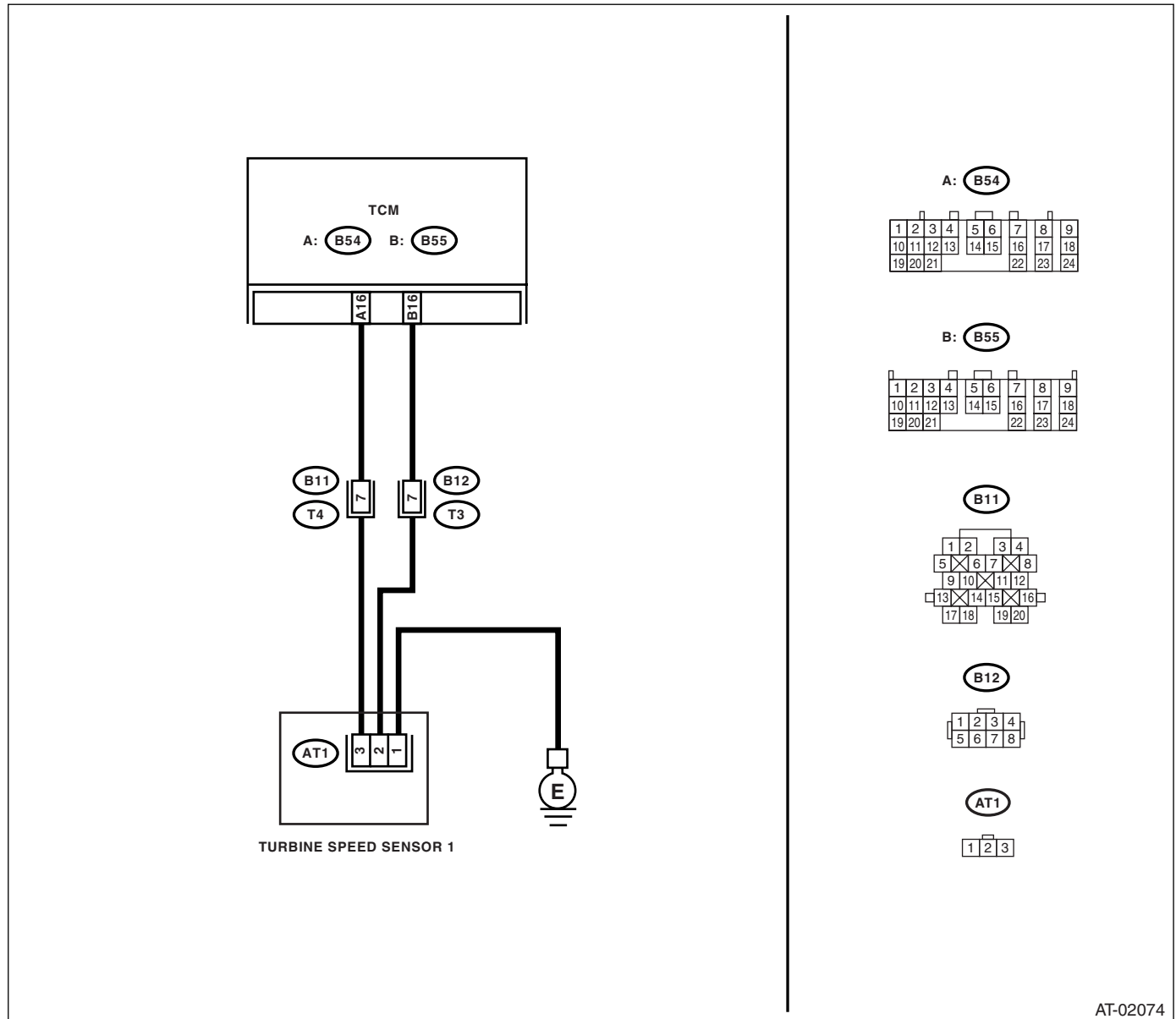

# Diagnostic Procedure with Diagnostic Trouble Code (DTC)

## AUTOMATIC TRANSMISSION (DIAGNOSTICS)

Step	Check	Yes	No
<b>1 CHECK HARNESS CONNECTOR BETWEEN TCM AND TRANSMISSION.</b> 1) Turn the ignition switch to OFF. 2) Disconnect the connectors from TCM and transmission. 3) Measure the resistance of harness between TCM connector and transmission connector.  <i>Connector &amp; terminal</i> <i>(B55) No. 16 — (B12) No. 7:</i> <i>(B54) No. 16 — (B11) No. 7:</i>	Is the resistance less than 1 $\Omega$ ?	Go to step 2.	Repair the open circuit of harness between TCM and transmission connector.
<b>2 CHECK HARNESS CONNECTOR BETWEEN TCM AND TRANSMISSION.</b> Measure the resistance of harness between TCM connector and chassis ground.  <i>Connector &amp; terminal</i> <i>(B55) No. 16 — Chassis ground:</i> <i>(B54) No. 16 — Chassis ground:</i>	Is the resistance more than 1 $M\Omega$ ?	Go to step 3.	Repair the short circuit of harness between TCM and chassis ground.
<b>3 CHECK TCM POWER SUPPLY OUTPUT.</b> 1) Connect the TCM connector. (Transmission connector is disconnected) 2) Turn the ignition switch to ON. (Engine OFF) 3) Measure the voltage between TCM connector and chassis ground.  <i>Connector &amp; terminal</i> <i>(B54) No. 16 (+) — Chassis ground (-):</i>	Is the voltage 10 — 13 V?	Go to step 4.	Go to step 5.
<b>4 CHECK TURBINE SPEED SENSOR INPUT CIRCUIT OF TCM.</b> Measure the voltage between TCM connector terminals.  <i>Connector &amp; terminal</i> <i>(B55) No. 16 (+) — (B54) No. 19 (-):</i>	Is the voltage 4 — 6 V?	Go to step 6.	Go to step 5.
<b>5 CHECK TCM I/O SIGNAL.</b> Check I/O signal of power supply, ground and PVIGN power supply relay. <Ref. to 5AT(diag)-11, ELECTRICAL SPECIFICATION, Transmission Control Module (TCM) I/O Signal.>	Is TCM I/O signal OK?	Replace the TCM. <Ref. to 5AT-56, Transmission Control Module (TCM).>	Repair the open or short circuit for power supply and ground. Perform the diagnosis according to DTC for PVIGN power supply relay.
<b>6 CHECK HARNESS ASSEMBLY (TURBINE SPEED SENSOR GROUND).</b> Check the installing condition of ground connecting harness of harness assembly (used for both of turbine speed sensor 1, rear vehicle speed sensor).	Is the ground connecting harness installed securely to the transmission body? Is there any serious damage in the harness and terminal?	Go to step 7.	When poor installation of ground occurs, install it securely. Replace the transmission assembly if the harness or terminal is damaged. <Ref. to 5AT-34, Automatic Transmission Assembly.>

# Diagnostic Procedure with Diagnostic Trouble Code (DTC)

AUTOMATIC TRANSMISSION (DIAGNOSTICS)

Step	Check	Yes	No
<p><b>7</b>    <b>CHECK HARNESS ASSEMBLY.</b>            1) Turn the ignition switch to OFF.            2) Disconnect the connector from transmission.            3) Disconnect the connector from turbine speed sensor 1.            4) Measure the resistance between transmission connector and turbine speed sensor 1 connector.</p> <p><b>Connector &amp; terminal</b>  <b>(T4) No. 7 — (AT1) No. 3:</b>  <b>(T3) No. 7 — (AT1) No. 2:</b>  <b>(AT1) No. 1 — Chassis ground:</b></p>	<p>Is the resistance less than 1 <math>\Omega</math>?</p>	<p>Go to step <b>8</b>.</p>	<p>Repair the open circuit of harness between TCM and transmission connector, or poor contact of connector.</p>
<p><b>8</b>    <b>CHECK HARNESS ASSEMBLY.</b>            Measure the resistance between transmission connector and chassis ground.</p> <p><b>Connector &amp; terminal</b>  <b>(T4) No. 7 — Chassis ground:</b>  <b>(T3) No. 7 — Chassis ground:</b></p>	<p>Is the resistance more than 1 <math>M\Omega</math>?</p>	<p>Go to step <b>9</b>.</p>	<p>Repair the short circuit of harness between TCM and transmission connector.</p>
<p><b>9</b>    <b>CHECK INPUT SIGNAL FOR TCM USING SUBARU SELECT MONITOR.</b>            1) Connect all the connectors.            2) Lift-up the vehicle and support with rigid racks.</p> <p>NOTE:            Raise all wheels off floor.</p> <p>3) Start the engine, and set the vehicle in 4th speed driving condition of manual mode.</p> <p>NOTE:            Turbine speed sensor 1 signal can be measured only on 4th speed.</p> <p>4) Read the current data of turbine speed sensor 1 using the Subaru Select Monitor. &lt;Ref. to 5AT(diag)-15, READ CURRENT DATA, OPERATION, Subaru Select Monitor.&gt;</p> <p>NOTE:            The speed difference between front and rear wheels may light the ABS warning light, but this indicates no malfunction. When AT control diagnosis is finished, perform the VDC memory clearance procedure of on-board diagnostics system. &lt;Ref. to VDC(diag)-24, Clear Memory Mode.&gt;</p>	<p>Does the value of the turbine speed sensor 1 change depending on the acceleration, deceleration and shifting range of the vehicle?</p>	<p>Even if the SPORT indicator light blinks, the system is in normal condition. A temporary poor contact of connector or harness may be the cause. Repair the poor contact of harness between ATF temperature sensor and transmission connector.</p>	<p>Replace the turbine speed sensor 1. &lt;Ref. to 5AT-52, Turbine Speed Sensor 1.&gt;</p>

# Diagnostic Procedure with Diagnostic Trouble Code (DTC)

AUTOMATIC TRANSMISSION (DIAGNOSTICS)

## E: DTC P0719 TORQUE CONVERTER/BRAKE SWITCH "B" CIRCUIT LOW

### DTC DETECTING CONDITION:

Brake switch malfunction, open input signal circuit

### TROUBLE SYMPTOM:

Brake down control is not operated at SPORT mode.

### WIRING DIAGRAM:

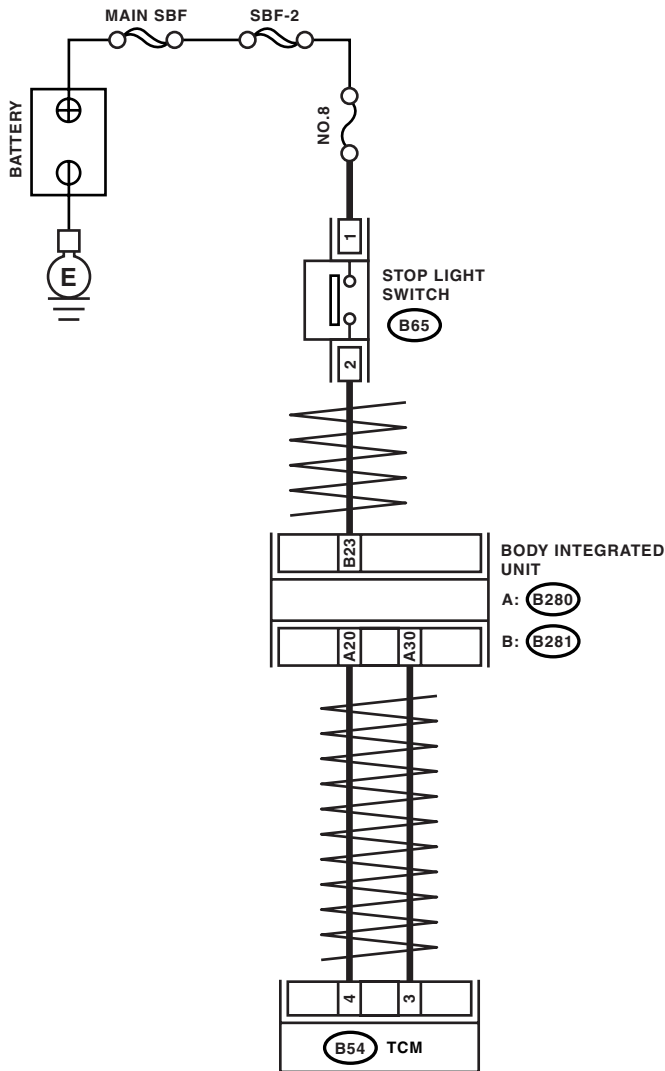

B65



B159

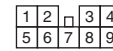

B54

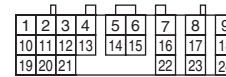

A: B280

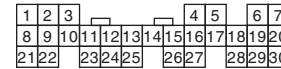

B: B281

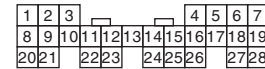

AT-03287

# Diagnostic Procedure with Diagnostic Trouble Code (DTC)

AUTOMATIC TRANSMISSION (DIAGNOSTICS)

Step	Check	Yes	No
1	<b>CHECK DTC.</b>	Is any of following DTC displayed? / AT CAN Communication Circuit / Output Speed Sensor Circuit / AT Vehicle Speed Sensor Circuit Malfunction (Rear Wheel)	Perform the diagnosis according to DTC. Go to step 2.
2	<b>CHECK THE BODY INTEGRATED UNIT.</b> 1) Turn the ignition switch to OFF. 2) Connect the Subaru Select Monitor to data link connector. 3) Turn the ignition switch to ON. (Engine OFF) 4) Turn the Subaru Select Monitor switch to ON. 5) Depress the brake pedal. 6) Read the data of brake pedal switch using Subaru Select Monitor. <Ref. to LAN(diag)-12, OPERATION, Subaru Select Monitor.>	Is ON displayed?	Go to step 3. Go to step 4.
3	<b>CHECK TCM.</b> Read the data of brake pedal switch using Subaru Select Monitor. <Ref. to 5AT(diag)-15, OPERATION, Subaru Select Monitor.>	Is ON displayed?	A temporary poor contact of connector or harness may be the cause. Check the poor contact. Replace the TCM. <Ref. to 5AT-56, Transmission Control Module (TCM).>
4	<b>CHECK BODY INTEGRATED UNIT INPUT SIGNAL.</b> 1) Disconnect the connector from body integrated unit. 2) Depress the brake pedal. 3) Measure the voltage between body integrated unit connector and chassis ground. <b>Connector &amp; terminal</b> <b>(B281) No. 23 (+) — Chassis ground (-):</b>	Is the voltage more than 10 V?	Go to step 7. Go to step 5.
5	<b>CHECK HARNESS CONNECTOR BETWEEN BODY INTEGRATED UNIT AND STOP LIGHT SWITCH.</b> 1) Turn the ignition switch to OFF. 2) Disconnect the connector from stop light switch. 3) Measure the resistance of harness between body integrated unit and stop light switch. <b>Connector &amp; terminal</b> <b>(B281) No. 23 — (B64) No. 2:</b>	Is the resistance less than 1 $\Omega$ ?	Go to step 6. Repair the open circuit of harness between body integrated unit and stop light switch.
6	<b>CHECK HARNESS CONNECTOR BETWEEN BODY INTEGRATED UNIT AND STOP LIGHT SWITCH.</b> Measure the resistance of harness between body integrated unit connector and stop light switch. <b>Connector &amp; terminal</b> <b>(B281) No. 23 — Chassis ground:</b>	Is the resistance more than 1 M $\Omega$ ?	Go to step 7. Repair the short circuit of harness between body integrated unit and stop light switch.
7	<b>CHECK POOR CONTACT.</b>	Is there poor contact in input signal of brake switch?	Repair the poor contact. Check the body integrated unit.

# Diagnostic Procedure with Diagnostic Trouble Code (DTC)

## AUTOMATIC TRANSMISSION (DIAGNOSTICS)

### F: DTC P0720 OUTPUT SPEED SENSOR CIRCUIT

#### DTC DETECTING CONDITION:

- AT vehicle speed signal is abnormal.
- The harness connector between TCM and vehicle speed sensor is shorted or open.

#### TROUBLE SYMPTOM:

- Deterioration of shifting quality.
- Driving performance is poor.

#### WIRING DIAGRAM:

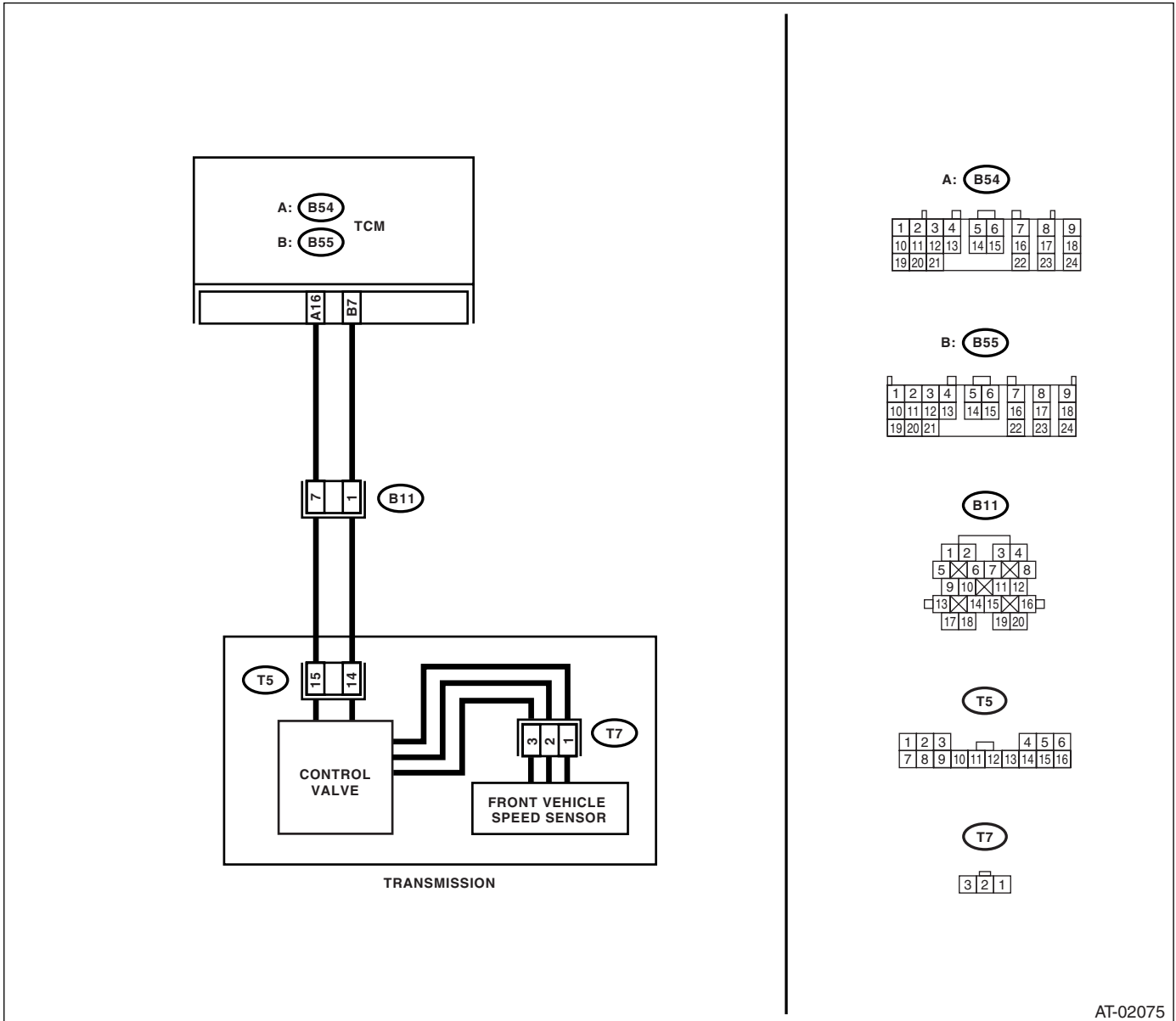

AT-02075



# Diagnostic Procedure with Diagnostic Trouble Code (DTC)

AUTOMATIC TRANSMISSION (DIAGNOSTICS)

Step	Check	Yes	No
<b>1 CHECK HARNESS CONNECTOR BETWEEN TCM AND TRANSMISSION.</b> 1) Turn the ignition switch to OFF. 2) Disconnect the connectors from TCM and transmission. 3) Measure the resistance of harness between TCM connector and transmission connector. <b>Connector &amp; terminal</b> <b>(B54) No. 16 — (B11) No. 7:</b> <b>(B55) No. 7 — (B11) No. 1:</b>	Is the resistance less than 1 $\Omega$ ?	Go to step 2.	Repair the open circuit of harness between TCM and transmission connector.
<b>2 CHECK HARNESS CONNECTOR BETWEEN TCM AND TRANSMISSION.</b> Measure the resistance of harness between TCM connector and chassis ground. <b>Connector &amp; terminal</b> <b>(B54) No. 16 — Chassis ground:</b> <b>(B55) No. 7 — Chassis ground:</b>	Is the resistance more than 1 $M\Omega$ ?	Go to step 3.	Repair the short circuit of harness between TCM and chassis ground.
<b>3 CHECK TCM POWER SUPPLY OUTPUT.</b> 1) Connect the connector to TCU. (Transmission connector is disconnected) 2) Turn the ignition switch to ON. (Engine OFF) 3) Measure the voltage between TCM connector and chassis ground. <b>Connector &amp; terminal</b> <b>(B54) No. 16 (+) — Chassis ground (-):</b>	Is the voltage 10 — 13 V?	Go to step 4.	Go to step 5.
<b>4 CHECK TURBINE SPEED SENSOR INPUT CIRCUIT OF TCM.</b> Measure the voltage between TCM connector terminals. <b>Connector &amp; terminal</b> <b>(B55) No. 7 (+) — (B54) No. 19 (-):</b>	Is the voltage 4 — 6 V?	Go to step 6.	Go to step 5.
<b>5 CHECK TCM I/O SIGNAL.</b> Check I/O signal of power supply, ground and PVIGN power supply relay. <Ref. to 5AT(diag)-11, ELECTRICAL SPECIFICATION, Transmission Control Module (TCM) I/O Signal.>	Is TCM I/O signal OK?	Replace the TCM. <Ref. to 5AT-56, Transmission Control Module (TCM).>	Repair the open or short circuit for power supply and ground. Perform the diagnosis according to DTC for PVIGN power supply relay.

# Diagnostic Procedure with Diagnostic Trouble Code (DTC)

## AUTOMATIC TRANSMISSION (DIAGNOSTICS)

Step	Check	Yes	No
<p><b>6</b>     <b>CHECK INPUT SIGNAL FOR TCM USING SUBARU SELECT MONITOR.</b>            1) Connect all the connectors.            2) Lift-up the vehicle and support with rigid racks.            NOTE:            Raise all wheels off floor.            3) Start the engine, and drive it.            4) Read the current data of front wheel speed using Subaru Select Monitor. &lt;Ref. to 5AT(diag)-15, READ CURRENT DATA, OPERATION, Subaru Select Monitor.&gt;            NOTE:            The speed difference between front and rear wheels may light the ABS warning light, but this indicates no malfunction. When AT control diagnosis is finished, perform the VDC memory clearance procedure of on-board diagnostics system. &lt;Ref. to VDC(diag)-18, CLEAR MEMORY MODE, OPERATION, Subaru Select Monitor.&gt;</p>	<p>Does the value of the front wheel speed change depending on the acceleration and deceleration of the vehicle?</p>	<p>Even if the SPORT indicator light blinks, the system is in normal condition. A temporary poor contact of connector or harness may be the cause. Repair the poor contact of harness between ATF temperature sensor and transmission connector.</p>	<p>Go to step 7.</p>
<p><b>7</b>     <b>CHECK HARNESS CONNECTOR BETWEEN TRANSMISSION AND CONTROL VALVE BODY.</b>            1) Turn the ignition switch to OFF.            2) Disconnect the connector from transmission.            3) Remove the transmission connector from bracket.            4) Lift-up the vehicle and place it on rigid racks.            NOTE:            Raise all wheels off floor.            5) Drain the ATF.  <b>CAUTION:</b>  <b>Do not drain ATF until it cools down.</b>            6) Remove the oil pan, and disconnect the connector from control valve body connector.            7) Measure the resistance between transmission connector and control valve body connector.  <b>Connector &amp; terminal</b>  <b>(B11) No. 7 — (T5) No. 15:</b>  <b>(B11) No. 1 — (T5) No. 14:</b></p>	<p>Is the resistance less than 1 <math>\Omega</math>?</p>	<p>Go to step 8.</p>	<p>Repair the open circuit of harness between control valve body connector and transmission connector.</p>
<p><b>8</b>     <b>CHECK HARNESS CONNECTOR BETWEEN TRANSMISSION AND CONTROL VALVE BODY.</b>            Measure the resistance between transmission ground and control valve body connector.  <b>Connector &amp; terminal</b>  <b>(T5) No. 15 — Transmission ground:</b>  <b>(T5) No. 14 — Transmission ground:</b></p>	<p>Is the resistance more than 1 M<math>\Omega</math>?</p>	<p>Go to step 9.</p>	<p>Repair the short circuit of harness between transmission connector and transmission ground.</p>

# Diagnostic Procedure with Diagnostic Trouble Code (DTC)

AUTOMATIC TRANSMISSION (DIAGNOSTICS)

Step	Check	Yes	No
<p><b>9</b>    <b>CHECK HARNESS CONNECTOR BETWEEN CONTROL VALVE BODY AND VEHICLE SPEED SENSOR.</b>            1) Disconnect the connector from vehicle speed sensor.            2) Measure the resistance of harness between control valve body connector and vehicle speed sensor connector.  <b>Connector &amp; terminal</b>  <b>(T5) No. 15 — (T7) No. 3:</b>  <b>(T5) No. 14 — (T7) No. 2:</b>  <b>(T7) No. 1 — Transmission ground:</b></p>	<p>Is the resistance less than 1 <math>\Omega</math>?</p>	<p>Go to step <b>10</b>.</p>	<p>Replace the control valve body.            &lt;Ref. to 5AT-53, Control Valve Body.&gt;</p>
<p><b>10</b>    <b>CHECK HARNESS CONNECTOR BETWEEN CONTROL VALVE BODY AND VEHICLE SPEED SENSOR.</b>            Measure the resistance of harness between control valve body connector and transmission ground.  <b>Connector &amp; terminal</b>  <b>(T5) No. 15 — Transmission ground:</b>  <b>(T5) No. 14 — Transmission ground:</b></p>	<p>Is the resistance more than 1 <math>M\Omega</math>?</p>	<p>Replace the vehicle speed sensor.</p>	<p>Replace the control valve body.            &lt;Ref. to 5AT-53, Control Valve Body.&gt;</p>

# Diagnostic Procedure with Diagnostic Trouble Code (DTC)

AUTOMATIC TRANSMISSION (DIAGNOSTICS)

## G: DTC P0724 TORQUE CONVERTER/BRAKE SWITCH "B" CIRCUIT HIGH

### DTC DETECTING CONDITION:

Brake switch malfunction, open input signal circuit

### TROUBLE SYMPTOM:

Gear is not shifted down when climbing a hill.

### WIRING DIAGRAM:

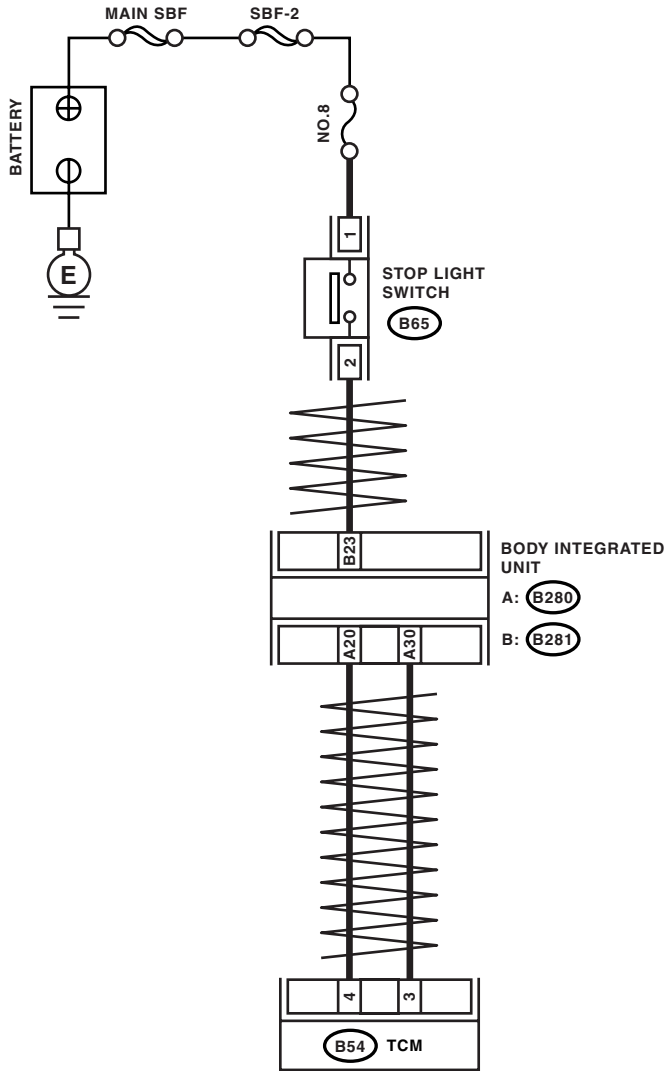

B65

1	2
3	4

B159

1	2	3	4	
5	6	7	8	9

B54

1	2	3	4	5	6	7	8	9
10	11	12	13	14	15	16	17	18
19	20	21				22	23	24

A: B280

1	2	3			4	5	6	7				
8	9	10	11	12	13	14	15	16	17	18	19	20
21	22	23	24	25	26	27	28	29	30			

B: B281

1	2	3			4	5	6	7			
8	9	10	11	12	13	14	15	16	17	18	19
20	21	22	23	24	25	26	27	28			

AT-03287

# Diagnostic Procedure with Diagnostic Trouble Code (DTC)

AUTOMATIC TRANSMISSION (DIAGNOSTICS)

Step	Check	Yes	No	
<b>1</b>	<b>CHECK DTC.</b>	Is any of following DTC detected? / AT CAN Communication Circuit / Output Speed Sensor Circuit / AT Vehicle Speed Sensor Circuit Malfunction (Rear Wheel)	Perform the diagnosis according to DTC.	Go to step 2.
<b>2</b>	<b>CHECK THE BODY INTEGRATED UNIT.</b> 1) Turn the ignition switch to OFF. 2) Connect the Subaru Select Monitor to data link connector. 3) Turn the ignition switch to ON. (Engine OFF) 4) Turn the Subaru Select Monitor switch to ON. 5) Read the data of brake pedal switch using Subaru Select Monitor. <Ref. to LAN(diag)-12, OPERATION, Subaru Select Monitor.>	Is OFF displayed?	Go to step 3.	Go to step 4.
<b>3</b>	<b>CHECK TCM.</b> Read the data of brake pedal switch using Subaru Select Monitor. <Ref. to 5AT(diag)-15, OPERATION, Subaru Select Monitor.>	Is OFF displayed?	A temporary poor contact of connector or harness may be the cause. Check the poor contact.	Replace the TCM. <Ref. to 5AT-56, Transmission Control Module (TCM).>
<b>4</b>	<b>CHECK BODY INTEGRATED UNIT INPUT SIGNAL.</b> 1) Disconnect the connector from body integrated unit. 2) Measure the voltage between body integrated unit connector and chassis ground. <b>Connector &amp; terminal</b> <b>(B281) No. 23 (+) — Chassis ground (-):</b>	Is the voltage more than 10 V?	Go to step 5.	Go to step 7.
<b>5</b>	<b>CHECK STOP LIGHT SWITCH.</b> 1) Turn the ignition switch to OFF. 2) Disconnect the connector from stop light switch. 3) Measure the resistance of harness between stop light switch connectors. <b>Terminals</b> <b>No. 1 — No. 2:</b>	Is the resistance more than 1 MΩ?	Go to step 6.	Replace the stop light switch.
<b>6</b>	<b>CHECK HARNESS CONNECTOR BETWEEN BODY INTEGRATED UNIT AND STOP LIGHT SWITCH.</b> 1) Turn the ignition switch to ON. 2) Measure the voltage of harness between body integrated unit connector and chassis ground. <b>Connector &amp; terminal</b> <b>(B281) No. 23 (+) — Chassis ground (-):</b>	Is the voltage less than 1 V?	Go to step 7.	Repair the short circuit of harness between TCM and stop light switch.
<b>7</b>	<b>CHECK POOR CONTACT.</b>	Is there poor contact in input signal of brake switch?	Repair the poor contact.	Check the body integrated unit.

## Diagnostic Procedure with Diagnostic Trouble Code (DTC)

AUTOMATIC TRANSMISSION (DIAGNOSTICS)

---

### H: DTC P0725 ENGINE SPEED INPUT CIRCUIT

#### DTC DETECTING CONDITION:

Information of engine speed is not correctly received from ECM.

#### TROUBLE SYMPTOM:

No lock-up occurs. (After engine is warmed-up)

	Step	Check	Yes	No
1	CHECK DTC OF ECM.	Is DTC of AT CAN communication circuit detected?	Perform the diagnosis according to DTC.	Go to step 2.
2	CHECK DTC OF TCM.	Is DTC of AT CAN communication circuit detected?	Perform the diagnosis according to DTC.	Go to step 3.
3	CHECK DTC OF TCM.	Is any of following DTC detected?/Output Speed Sensor Circuit/AT Vehicle Speed Sensor Circuit Malfunction (Rear Wheel)	Perform the diagnosis according to DTC.	Replace the TCM. <Ref. to 5AT-56, Transmission Control Module (TCM).>

### I: DTC P0731 GEAR 1 INCORRECT RATIO

#### NOTE:

Refer to DTC P0736 for diagnostic procedure. <Ref. to 5AT(diag)-53, DTC P0736 REVERSE INCORRECT RATIO, Diagnostic Procedure with Diagnostic Trouble Code (DTC).>

### J: DTC P0732 GEAR 2 INCORRECT RATIO

#### NOTE:

Refer to DTC P0736 for diagnostic procedure. <Ref. to 5AT(diag)-53, DTC P0736 REVERSE INCORRECT RATIO, Diagnostic Procedure with Diagnostic Trouble Code (DTC).>

### K: DTC P0733 GEAR 3 INCORRECT RATIO

#### NOTE:

Refer to DTC P0736 for diagnostic procedure. <Ref. to 5AT(diag)-53, DTC P0736 REVERSE INCORRECT RATIO, Diagnostic Procedure with Diagnostic Trouble Code (DTC).>

### L: DTC P0734 GEAR 4 INCORRECT RATIO

#### NOTE:

Refer to DTC P0736 for diagnostic procedure. <Ref. to 5AT(diag)-53, DTC P0736 REVERSE INCORRECT RATIO, Diagnostic Procedure with Diagnostic Trouble Code (DTC).>

### M: DTC P0735 GEAR 5 INCORRECT RATIO

#### NOTE:

Refer to DTC P0736 for diagnostic procedure. <Ref. to 5AT(diag)-53, DTC P0736 REVERSE INCORRECT RATIO, Diagnostic Procedure with Diagnostic Trouble Code (DTC).>

# Diagnostic Procedure with Diagnostic Trouble Code (DTC)

AUTOMATIC TRANSMISSION (DIAGNOSTICS)

## N: DTC P0736 REVERSE INCORRECT RATIO

### DTC DETECTING CONDITION:

Target gear ratio and actual gear ratio do not match.

### TROUBLE SYMPTOM:

- Shift point is too high or too low.
- Excessive shift shock.
- Gear is not changed.
- The vehicle does not move in D or R range with the engine running at high speed.

	Step	Check	Yes	No
1	<b>CHECK DTC OF TCM.</b>	Is any DTC of the followings detected? P0715, P0720, P0753, P0758, P0763, P0768, P0773, P0751, P0756, P0761, P0766, P0771, P1706, P1710, P1798, P1799	Perform the diagnosis according to DTC.	Go to step 2.
2	<b>CHECK TURBINE SPEED SENSOR USING SUBARU SELECT MONITOR.</b> 1) Lift-up the vehicle and support with rigid racks. NOTE: Raise all wheels off floor. 2) Start the engine, and drive it. 3) Read the current data of torque converter turbine speed using Subaru Select Monitor. <Ref. to 5AT(diag)-15, READ CURRENT DATA, OPERATION, Subaru Select Monitor.> NOTE: The speed difference between front and rear wheels may light the ABS warning light, but this indicates no malfunction. When AT control diagnosis is finished, perform the VDC memory clearance procedure of on-board diagnostics system. <Ref. to VDC(diag)-18, CLEAR MEMORY MODE, OPERATION, Subaru Select Monitor.>	Does the displayed value of the Subaru Select Monitor change according to engine speed and shifting?	Go to step 3.	Perform the diagnosis according to DTC P0715, P1710.
3	<b>CHECK FRONT AND REAR VEHICLE SPEED SENSORS.</b>	Do the values displayed for each of the Subaru Select Monitor and the speedometer substantially match?	Go to step 4.	Perform the diagnosis according to DTC P0720, P1706.
4	<b>CHECK INHIBITOR SWITCH.</b>	Do the values displayed for the Subaru Select Monitor and the meter indicator match?	Go to step 5.	Perform the diagnosis according to DTC P0705.
5	<b>DRIVING CHECK.</b> 1) Turn the ignition switch to OFF. 2) After restarting the engine, check that the SPORT indicator light is not blinking, and perform a drive check based on the inspection mode. <Ref. to 5AT(diag)-19, PROCEDURE, Inspection Mode.>	Is DTC displayed again?	Check the DTC. Then, when proceeded again to step 5, go to step 6.	Go to step 6.
6	<b>CHECK AFTER REPAIR.</b>	Is the trouble symptom inrepairable (malfunction in shifting such as excessive shift shock, engine speed increases excessively when shifting)?	Replace the transmission assembly.	Temporary poor contact occurs. Check that the harness connector is not faulty.

## Diagnostic Procedure with Diagnostic Trouble Code (DTC)

AUTOMATIC TRANSMISSION (DIAGNOSTICS)

### O: DTC P0741 TORQUE CONVERTER CLUTCH CIRCUIT PERFORMANCE OR STUCK OFF

#### DTC DETECTING CONDITION:

- Defective lock-up clutch or torque converter assembly
- Defective control valve
- Defective turbine speed sensor 1 or 2

#### TROUBLE SYMPTOM:

No lock-up occurs. (After engine is warmed-up)

Step	Check	Yes	No
1	<b>CHECK DTC OF TCM.</b>	Perform the diagnosis according to each DTC.	Go to step 2.
2	<b>DRIVING CHECK FOR LOCK-UP CONDITION</b> 1) Perform a drive check based on the inspection mode with the following conditions. <Ref. to 5AT(diag)-19, PROCEDURE, Inspection Mode.> (1) Read the current data of throttle opening angle using Subaru Select Monitor. <Ref. to 5AT(diag)-15, READ CURRENT DATA, OPERATION, Subaru Select Monitor.> (2) Keep the same vehicle speed at 60 km/h with 10% or less throttle opening angle which is read currently on Subaru Select Monitor. <Ref. to 5AT(diag)-15, READ CURRENT DATA, OPERATION, Subaru Select Monitor.> (3) Read the current data of L/U solenoid target pressure using Subaru Select Monitor. <Ref. to 5AT(diag)-15, READ CURRENT DATA, OPERATION, Subaru Select Monitor.> (4) Check the engine speed and turbine speed when the L/U solenoid target value displayed on Subaru Select Monitor is 500 kPa or more.	Are the engine speed and turbine speed almost the same?  Temporary poor contact or open circuit occurs. Recheck that the harness connector has no faulty.	Go to step 3.



# Diagnostic Procedure with Diagnostic Trouble Code (DTC)

AUTOMATIC TRANSMISSION (DIAGNOSTICS)

	Step	Check	Yes	No
3	<p><b>DRIVING CHECK FOR LOCK-UP CONDITION</b></p> <p>1) Clear the memory. &lt;Ref. to 5AT(diag)-17, OPERATION, Subaru Select Monitor.&gt;</p> <p>2) Perform a drive check based on the inspection mode with the following conditions. &lt;Ref. to 5AT(diag)-19, PROCEDURE, Inspection Mode.&gt;</p> <p>(1) Read the current data of throttle opening angle using Subaru Select Monitor. &lt;Ref. to 5AT(diag)-15, READ CURRENT DATA, OPERATION, Subaru Select Monitor.&gt;</p> <p>(2) Keep the same vehicle speed at 60 km/h with 10% or less throttle opening angle which is read currently on Subaru Select Monitor. &lt;Ref. to 5AT(diag)-15, READ CURRENT DATA, OPERATION, Subaru Select Monitor.&gt;</p> <p>(3) Read the current data of L/U solenoid target pressure using Subaru Select Monitor. &lt;Ref. to 5AT(diag)-15, READ CURRENT DATA, OPERATION, Subaru Select Monitor.&gt;</p> <p>(4) Drive the vehicle continuously for one minutes or more with the L/U solenoid target value displayed on Subaru Select Monitor at 500 kPa or more.</p> <p>3) Turn the ignition switch to OFF.</p> <p>4) Turn the ignition switch to ON. (Engine ON)</p> <p>5) Perform the step 2) again.</p>	<p>Is DTC P0741 displayed with the SPORT indicator light blinking?</p>	<p>Replace the transmission assembly when DTC P0741 is displayed.</p> <p>When DTC other than P0741 is displayed, perform the diagnosis corresponding to the DTC.</p>	<p>Temporary poor contact or open circuit occurs.</p> <p>Recheck that the harness connector has no faulty.</p>

# Diagnostic Procedure with Diagnostic Trouble Code (DTC)

AUTOMATIC TRANSMISSION (DIAGNOSTICS)

## P: DTC P0743 TORQUE CONVERTER CLUTCH CIRCUIT ELECTRICAL

### DTC DETECTING CONDITION:

The output signal circuit of lock up solenoid is open or shorted.

### TROUBLE SYMPTOM:

No lock-up occurs. (After engine is warmed-up)

### WIRING DIAGRAM:

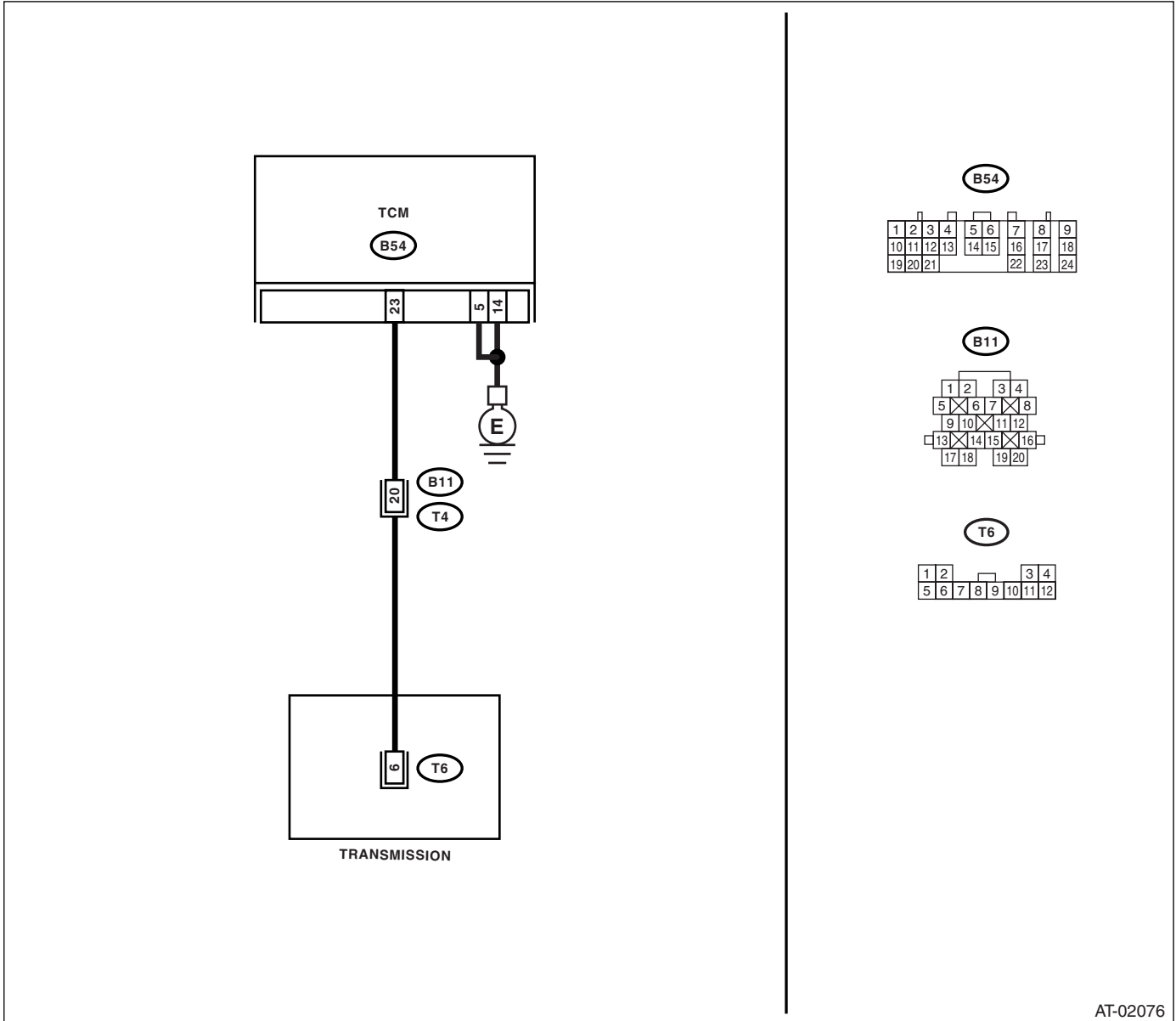

AT-02076

# Diagnostic Procedure with Diagnostic Trouble Code (DTC)

AUTOMATIC TRANSMISSION (DIAGNOSTICS)

Step	Check	Yes	No
<b>1 CHECK HARNESS CONNECTOR BETWEEN TCM AND TRANSMISSION.</b> 1) Turn the ignition switch to OFF. 2) Disconnect the connectors from TCM and transmission. 3) Measure the resistance of harness between TCM connector and transmission connector. <b>Connector &amp; terminal</b> <b>(B54) No. 23 — (B11) No. 20:</b> <b>(B54) No. 5 — Chassis ground:</b> <b>(B54) No. 14 — Chassis ground:</b>	Is the resistance less than 1 $\Omega$ ?	Go to step 2.	Repair the open circuit of harness between TCM connector and transmission connector.
<b>2 CHECK HARNESS CONNECTOR BETWEEN TCM AND CHASSIS GROUND.</b> Measure the resistance of harness between TCM connector and chassis ground. <b>Connector &amp; terminal</b> <b>(B54) No. 23 — Chassis ground:</b>	Is the resistance more than 1 $M\Omega$ ?	Go to step 3.	Repair the short circuit of harness between TCM connector and transmission connector.
<b>3 CHECK HARNESS CONNECTOR BETWEEN TRANSMISSION AND CONTROL VALVE BODY.</b> 1) Turn the ignition switch to OFF. 2) Disconnect the connector from transmission. 3) Remove the transmission connector from bracket. 4) Lift-up the vehicle and place it on rigid racks. NOTE: Raise all wheels off floor. 5) Drain the ATF. NOTE: Do not drain ATF until it cools down. 6) Remove the oil pan, and disconnect the control valve body connector. 7) Measure the resistance between transmission connector and control valve body connector. <b>Connector &amp; terminal</b> <b>(T4) No. 20 — (T6) No. 6:</b>	Is the resistance less than 1 $\Omega$ ?	Go to step 4.	Repair the open circuit of harness between transmission connector and control valve body connector.
<b>4 CHECK HARNESS CONNECTOR BETWEEN TRANSMISSION AND CONTROL VALVE BODY.</b> Measure the resistance between chassis ground and control valve body connector. <b>Connector &amp; terminal</b> <b>(T6) No. 6 — Chassis ground:</b>	Is the resistance more than 1 $M\Omega$ ?	Go to step 5.	Repair the short circuit of harness between control valve body connector and transmission ground.
<b>5 CHECK LOCK-UP SOLENOID.</b> Measure the resistance between transmission ground and control valve body connector. <b>Connector &amp; terminal</b> <b>(T6) No. 6 — Transmission ground:</b>	Is the resistance between 3 — 9 $\Omega$ ?	Go to step 6.	Replace the control valve body. <Ref. to 5AT-53, Control Valve Body.>

# Diagnostic Procedure with Diagnostic Trouble Code (DTC)

## AUTOMATIC TRANSMISSION (DIAGNOSTICS)

	Step	Check	Yes	No
6	<b>CHECK POOR CONTACT.</b> Check that there are no poor contact in TCM connector, transmission connector and control valve body connector.	Is there any loosing terminal, entering foreign matter, damaging connector body?	Repair the poor contact.	Go to step 7.
7	<b>CHECK AFTER REPAIR.</b> 1) Perform the clear memory mode. 2) Drive for a while, read the DTC, and check that there is no faulty.	Is DTC displayed?	Replace the TCM. <Ref. to 5AT-56, Transmission Control Module (TCM).>	Temporary poor contact or open circuit occurs. Recheck that the harness connector has no faulty.

# Diagnostic Procedure with Diagnostic Trouble Code (DTC)

AUTOMATIC TRANSMISSION (DIAGNOSTICS)

## Q: DTC P0748 PRESSURE CONTROL SOLENOID "A" ELECTRICAL

### DTC DETECTING CONDITION:

Output signal circuit of line pressure solenoid is open or shorted.

### TROUBLE SYMPTOM:

Excessive shift shock

### WIRING DIAGRAM:

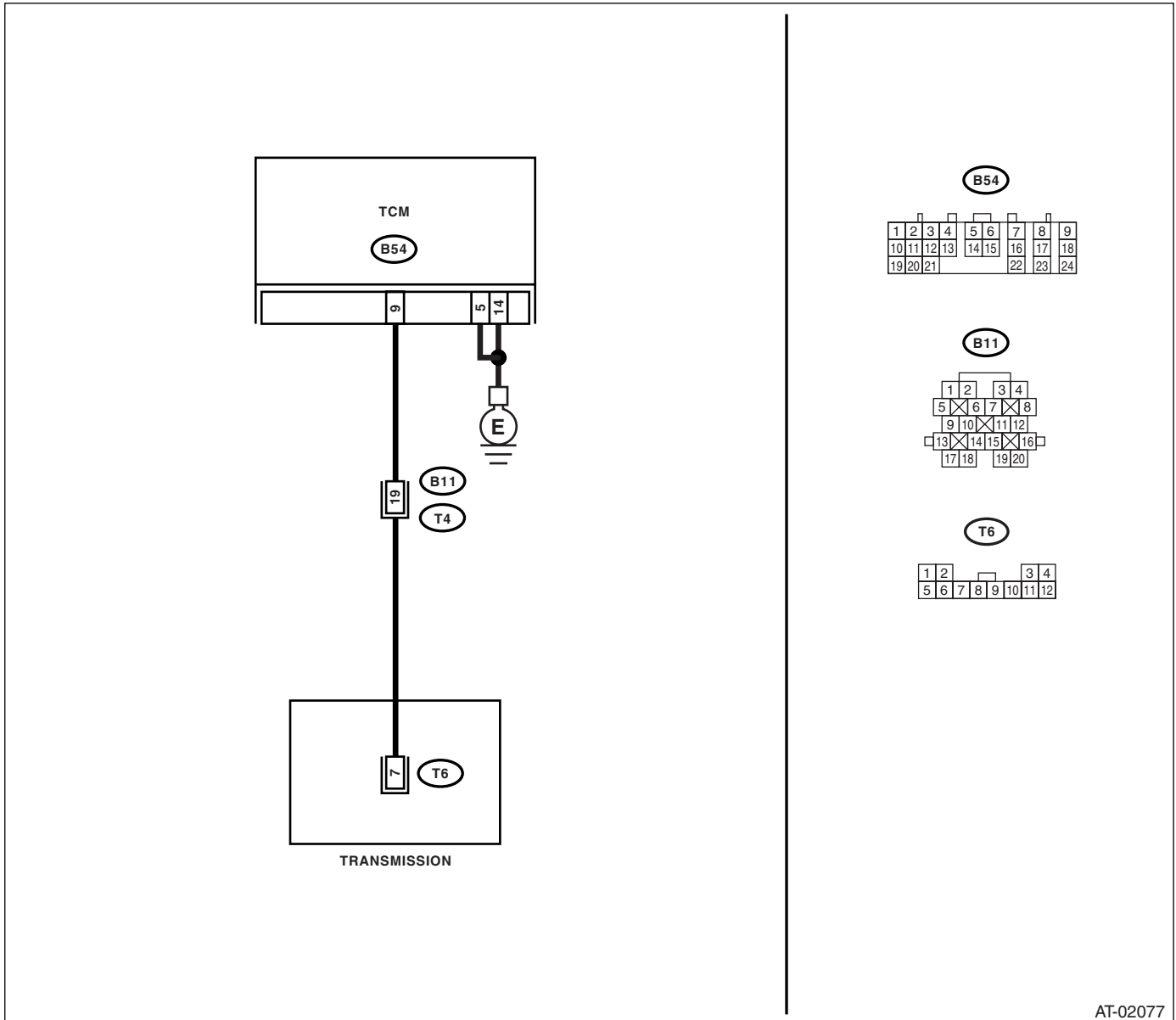

AT-02077

# Diagnostic Procedure with Diagnostic Trouble Code (DTC)

## AUTOMATIC TRANSMISSION (DIAGNOSTICS)

Step	Check	Yes	No
<p><b>1 CHECK HARNESS CONNECTOR BETWEEN TCM AND TRANSMISSION.</b></p> <p>1) Turn the ignition switch to OFF. 2) Disconnect the connectors from TCM and transmission. 3) Measure the resistance of harness between TCM connector and transmission connector.</p> <p><b>Connector &amp; terminal</b> <b>(B54) No. 9 — (B11) No. 19:</b> <b>(B54) No. 5 — Chassis ground:</b> <b>(B54) No. 14 — Chassis ground:</b></p>	Is the resistance less than 1 $\Omega$ ?	Go to step 2.	Repair the open circuit of harness between TCM connector and transmission connector.
<p><b>2 CHECK HARNESS CONNECTOR BETWEEN TCM AND CHASSIS GROUND.</b></p> <p>Measure the resistance between TCM connector and chassis ground.</p> <p><b>Connector &amp; terminal</b> <b>(B54) No. 9 — Chassis ground:</b></p>	Is the resistance more than 1 $M\Omega$ ?	Go to step 3.	Repair the short circuit of harness between TCM connector and transmission connector.
<p><b>3 CHECK HARNESS CONNECTOR BETWEEN TRANSMISSION AND CONTROL VALVE BODY.</b></p> <p>1) Turn the ignition switch to OFF. 2) Disconnect the connector from transmission. 3) Remove the transmission connector from bracket. 4) Lift-up the vehicle and place it on rigid racks.</p> <p>NOTE: Raise all wheels off floor. 5) Drain the ATF.</p> <p><b>CAUTION:</b> <b>Do not drain ATF until it cools down.</b></p> <p>6) Remove the oil pan, and disconnect the control valve body connector. 7) Measure the resistance between transmission connector and control valve body connector.</p> <p><b>Connector &amp; terminal</b> <b>(T4) No. 19 — (T6) No. 7:</b></p>	Is the resistance less than 1 $\Omega$ ?	Go to step 4.	Repair the open circuit of harness between transmission connector and control valve body connector.
<p><b>4 CHECK HARNESS CONNECTOR BETWEEN TRANSMISSION AND CONTROL VALVE BODY.</b></p> <p>Measure the resistance between transmission ground and control valve body connector.</p> <p><b>Connector &amp; terminal</b> <b>(T6) No. 7 — Chassis ground:</b></p>	Is the resistance more than 1 $M\Omega$ ?	Go to step 5.	Repair the short circuit of harness between control valve body connector and transmission ground.
<p><b>5 CHECK LINE PRESSURE SOLENOID.</b></p> <p>Measure the resistance between transmission ground and control valve body connector.</p> <p><b>Connector &amp; terminal</b> <b>(T6) No. 7 — Transmission ground:</b></p>	Is the resistance between 3 — 9 $\Omega$ ?	Go to step 6.	Replace the control valve body. <Ref. to 5AT-53, Control Valve Body.>
<p><b>6 CHECK POOR CONTACT.</b></p> <p>Check that there are no poor contact in TCM connector, transmission connector and control valve body connector.</p>	Is there any loosing terminal, entering foreign matter, damaging connector body?	Repair the poor contact.	Go to step 7.
<p><b>7 CHECK AFTER REPAIR.</b></p> <p>1) Perform the clear memory mode. 2) Drive for a while, read the DTC, and check that there is no faulty.</p>	Is DTC displayed?	Replace the TCM. <Ref. to 5AT-56, Transmission Control Module (TCM).>	Temporary poor contact or open circuit occurs. Recheck that the harness connector has no faulty.

# Diagnostic Procedure with Diagnostic Trouble Code (DTC)

AUTOMATIC TRANSMISSION (DIAGNOSTICS)

## R: DTC P0751 SHIFT SOLENOID "A" PERFORMANCE OR STUCK OFF

### DTC DETECTING CONDITION:

Output signal of front brake solenoid does not match with oil pressure.

### TROUBLE SYMPTOM:

Locked to 4th or 5th gear.

### WIRING DIAGRAM:

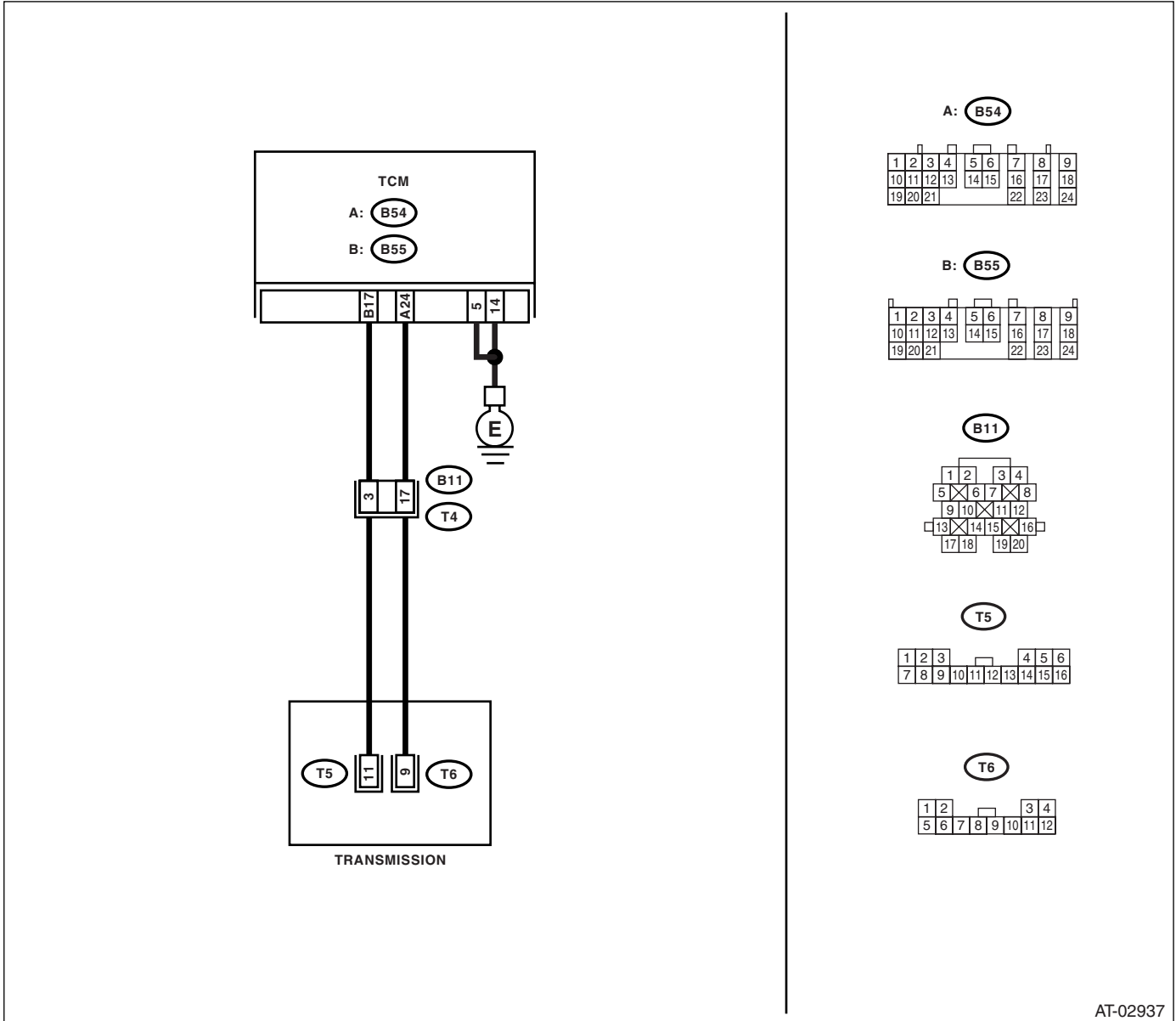

AT-02937

# Diagnostic Procedure with Diagnostic Trouble Code (DTC)

## AUTOMATIC TRANSMISSION (DIAGNOSTICS)

Step	Check	Yes	No
<b>1 CHECK HARNESS CONNECTOR BETWEEN TCM AND TRANSMISSION.</b> 1) Turn the ignition switch to OFF. 2) Disconnect the connectors from TCM and transmission. 3) Measure the resistance of harness between TCM and transmission connector. <i>Connector &amp; terminal</i> (B54) No. 24 — (B11) No. 17: (B55) No. 17 — (B11) No. 3: (B54) No. 5 — Chassis ground: (B54) No. 14 — Chassis ground:	Is the resistance less than 1 $\Omega$ ?	Go to step 2.	Repair the open circuit of harness between TCM and transmission connector.
<b>2 CHECK HARNESS CONNECTOR BETWEEN TCM AND CHASSIS GROUND.</b> Measure the resistance of harness between TCM connector and chassis ground. <i>Connector &amp; terminal</i> (B55) No. 17 — Chassis ground:	Is the resistance more than 1 $M\Omega$ ?	Go to step 3.	Repair the short circuit of harness between TCM and transmission connector.
<b>3 CHECK INPUT SIGNAL FOR TCM USING SUBARU SELECT MONITOR.</b> 1) Connect all the connectors. 2) Turn the ignition switch to ON. (Engine OFF) 3) Check input signal of Fr/B oil pressure SW.	Is OFF displayed?	Go to step 4.	Go to step 6.
<b>4 CHECK INPUT SIGNAL FOR TCM USING SUBARU SELECT MONITOR.</b> 1) Turn the ignition switch to OFF. 2) Turn the ignition switch to ON. (Engine ON) 3) Shift to 1st speed while checking the current gear position using Subaru Select Monitor. 4) Check input signal of Fr/B oil pressure SW.	Is ON displayed?	Even if the SPORT indicator light blinks, the system is in normal condition. A temporary poor contact of connector or harness may be the cause. Repair the poor contact of harness in the solenoid output and oil pressure SW input.	Go to step 5.



# Diagnostic Procedure with Diagnostic Trouble Code (DTC)

AUTOMATIC TRANSMISSION (DIAGNOSTICS)

Step	Check	Yes	No
<p><b>5</b></p> <p><b>CHECK HARNESS CONNECTOR BETWEEN TRANSMISSION AND CONTROL VALVE BODY.</b></p> <p>1) Turn the ignition switch to OFF.                      2) Disconnect the connector from transmission.                      3) Remove the transmission connector from bracket.                      4) Lift-up the vehicle and place it on rigid racks.</p> <p>NOTE:                      Raise all wheels off floor.                      5) Drain the ATF.</p> <p><b>CAUTION:</b>  <b>Do not drain ATF until it cools down.</b></p> <p>6) Remove the oil pan, and disconnect the control valve body connector.                      7) Measure the resistance between transmission connector and control valve body connector.</p> <p><b>Connector &amp; terminal</b>  <b>(B11) No. 17 — (T6) No. 9:</b>  <b>(B11) No. 3 — (T5) No. 11:</b></p>	<p>Is the resistance less than 1 <math>\Omega</math>?</p>	<p>Replace the control valve body.                      &lt;Ref. to 5AT-53, Control Valve Body.&gt;</p>	<p>Replace the transmission harness assembly.</p>
<p><b>6</b></p> <p><b>CHECK HARNESS CONNECTOR BETWEEN TRANSMISSION AND CONTROL VALVE BODY.</b></p> <p>1) Turn the ignition switch to OFF.                      2) Disconnect the connector from transmission.                      3) Remove the transmission connector from bracket.                      4) Lift-up the vehicle and place it on rigid racks.</p> <p>NOTE:                      Raise all wheels off floor.                      5) Drain the ATF.</p> <p><b>CAUTION:</b>  <b>Do not drain ATF until it cools down.</b></p> <p>6) Remove the oil pan, and disconnect the control valve body connector.                      7) Measure the resistance between transmission ground and control valve body connector.</p> <p><b>Connector &amp; terminal</b>  <b>(T4) No. 3 — Transmission ground:</b></p>	<p>Is the resistance more than 1 <math>M\Omega</math>?</p>	<p>Replace the control valve body.                      &lt;Ref. to 5AT-53, Control Valve Body.&gt;</p>	<p>Replace the transmission harness assembly.</p>

# Diagnostic Procedure with Diagnostic Trouble Code (DTC)

AUTOMATIC TRANSMISSION (DIAGNOSTICS)

## S: DTC P0753 SHIFT SOLENOID "A" ELECTRICAL

### DTC DETECTING CONDITION:

Output signal circuit of front brake solenoid is open or shorted.

### TROUBLE SYMPTOM:

Locked to 4th or 5th gear.

### WIRING DIAGRAM:

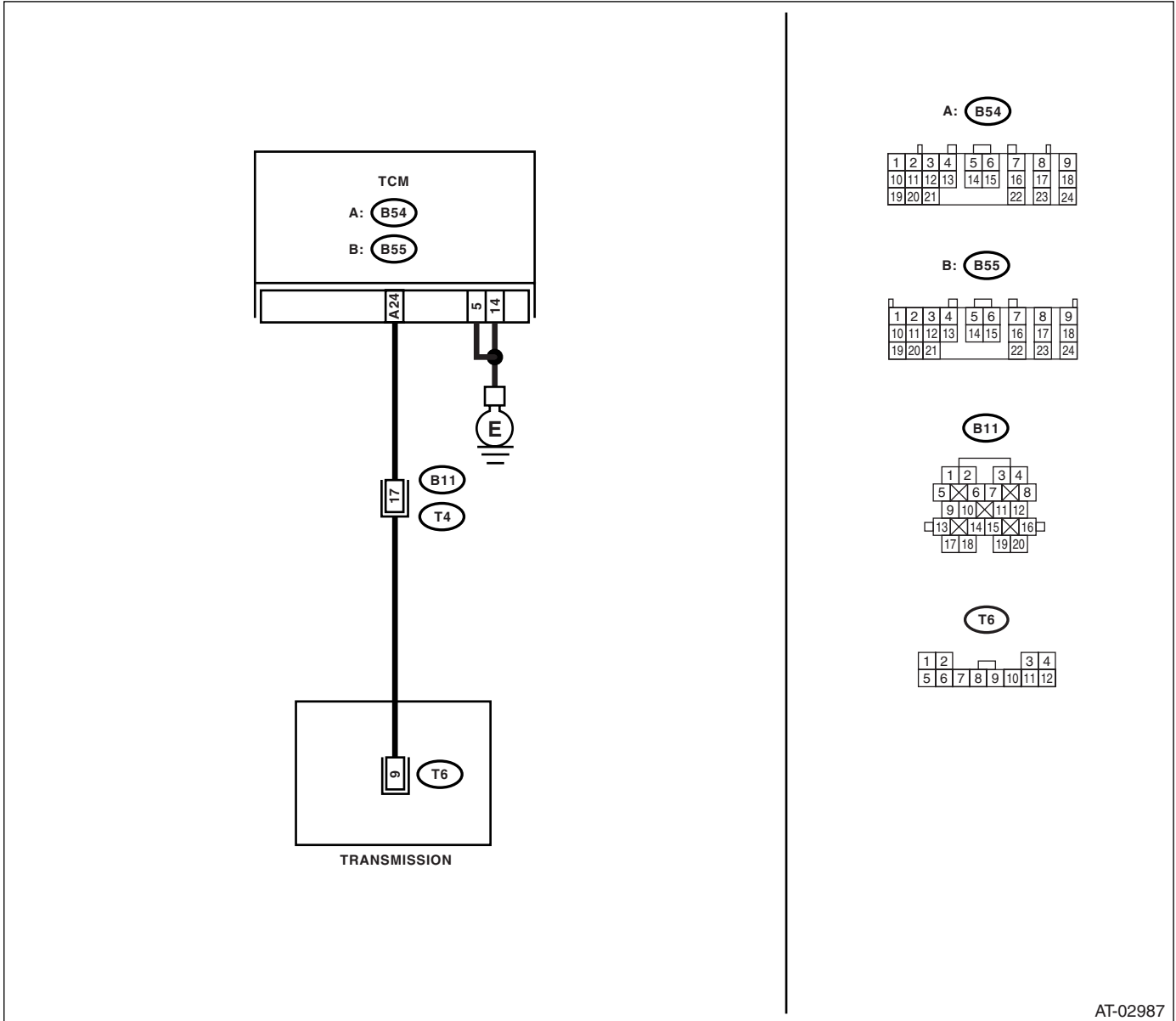

AT-02987

# Diagnostic Procedure with Diagnostic Trouble Code (DTC)

AUTOMATIC TRANSMISSION (DIAGNOSTICS)

Step	Check	Yes	No
<p><b>1 CHECK HARNESS CONNECTOR BETWEEN TCM AND TRANSMISSION.</b></p> <p>1) Turn the ignition switch to OFF. 2) Disconnect the connectors from TCM and transmission. 3) Measure the resistance of harness between TCM connector and transmission connector.</p> <p><b>Connector &amp; terminal</b> <b>(B54) No. 24 — (B11) No. 17:</b> <b>(B54) No. 5 — Chassis ground:</b> <b>(B54) No. 14 — Chassis ground:</b></p>	Is the resistance less than 1 $\Omega$ ?	Go to step 2.	Repair the open circuit of harness between TCM connector and transmission connector.
<p><b>2 CHECK HARNESS CONNECTOR BETWEEN TCM AND CHASSIS GROUND.</b></p> <p>Measure the resistance of harness between TCM connector and chassis ground.</p> <p><b>Connector &amp; terminal</b> <b>(B54) No. 24 — Chassis ground:</b></p>	Is the resistance more than 1 $M\Omega$ ?	Go to step 3.	Repair the short circuit of harness between TCM connector and transmission connector.
<p><b>3 CHECK HARNESS CONNECTOR BETWEEN TRANSMISSION AND CONTROL VALVE BODY.</b></p> <p>1) Turn the ignition switch to OFF. 2) Disconnect the connector from transmission. 3) Remove the transmission connector from bracket. 4) Lift-up the vehicle and place it on rigid racks.</p> <p>NOTE: Raise all wheels off floor. 5) Drain the ATF.</p> <p><b>CAUTION:</b> <b>Do not drain ATF until it cools down.</b></p> <p>6) Remove the oil pan, and disconnect the control valve body connector. 7) Measure the resistance between transmission connector and control valve body connector.</p> <p><b>Connector &amp; terminal</b> <b>(T4) No. 17 — (T6) No. 9:</b></p>	Is the resistance less than 1 $\Omega$ ?	Go to step 4.	Repair the open circuit of harness between transmission connector and control valve body connector.
<p><b>4 CHECK HARNESS CONNECTOR BETWEEN TRANSMISSION AND CONTROL VALVE BODY.</b></p> <p>Measure the resistance between transmission ground and control valve body connector.</p> <p><b>Connector &amp; terminal</b> <b>(T6) No. 9 — Transmission ground:</b></p>	Is the resistance more than 1 $M\Omega$ ?	Go to step 5.	Repair the short circuit of harness between control valve body and transmission connector.
<p><b>5 CHECK FRONT BRAKE SOLENOID.</b></p> <p>Measure the resistance between transmission ground and control valve body connector.</p> <p><b>Connector &amp; terminal</b> <b>(T6) No. 9 — Transmission ground:</b></p>	Is the resistance between 3 — 9 $\Omega$ ?	Go to step 6.	Replace the control valve body. <Ref. to 5AT-53, Control Valve Body.>

# Diagnostic Procedure with Diagnostic Trouble Code (DTC)

## AUTOMATIC TRANSMISSION (DIAGNOSTICS)

Step	Check	Yes	No
<b>6</b> <b>CHECK POOR CONTACT.</b> Check that there are no poor contact in TCM connector, transmission connector and control valve body connector.	Is there any loosing terminal, entering foreign matter, damaging connector body?	Repair the poor contact.	Go to step 7.
<b>7</b> <b>CHECK AFTER REPAIR.</b> 1) Perform the clear memory mode. 2) Drive for a while, read the DTC, and check that there is no faulty.	Is DTC displayed?	Replace the TCM. <Ref. to 5AT-56, Transmission Control Module (TCM).>	Temporary poor contact or open circuit occurs. Recheck that the harness connector has no faulty.

# Diagnostic Procedure with Diagnostic Trouble Code (DTC)

AUTOMATIC TRANSMISSION (DIAGNOSTICS)

## T: DTC P0756 SHIFT SOLENOID "B" PERFORMANCE OR STUCK OFF

### DTC DETECTING CONDITION:

Output signal value of input clutch solenoid and oil pressure does not match.

### TROUBLE SYMPTOM:

Locked to 4th gear.

### WIRING DIAGRAM:

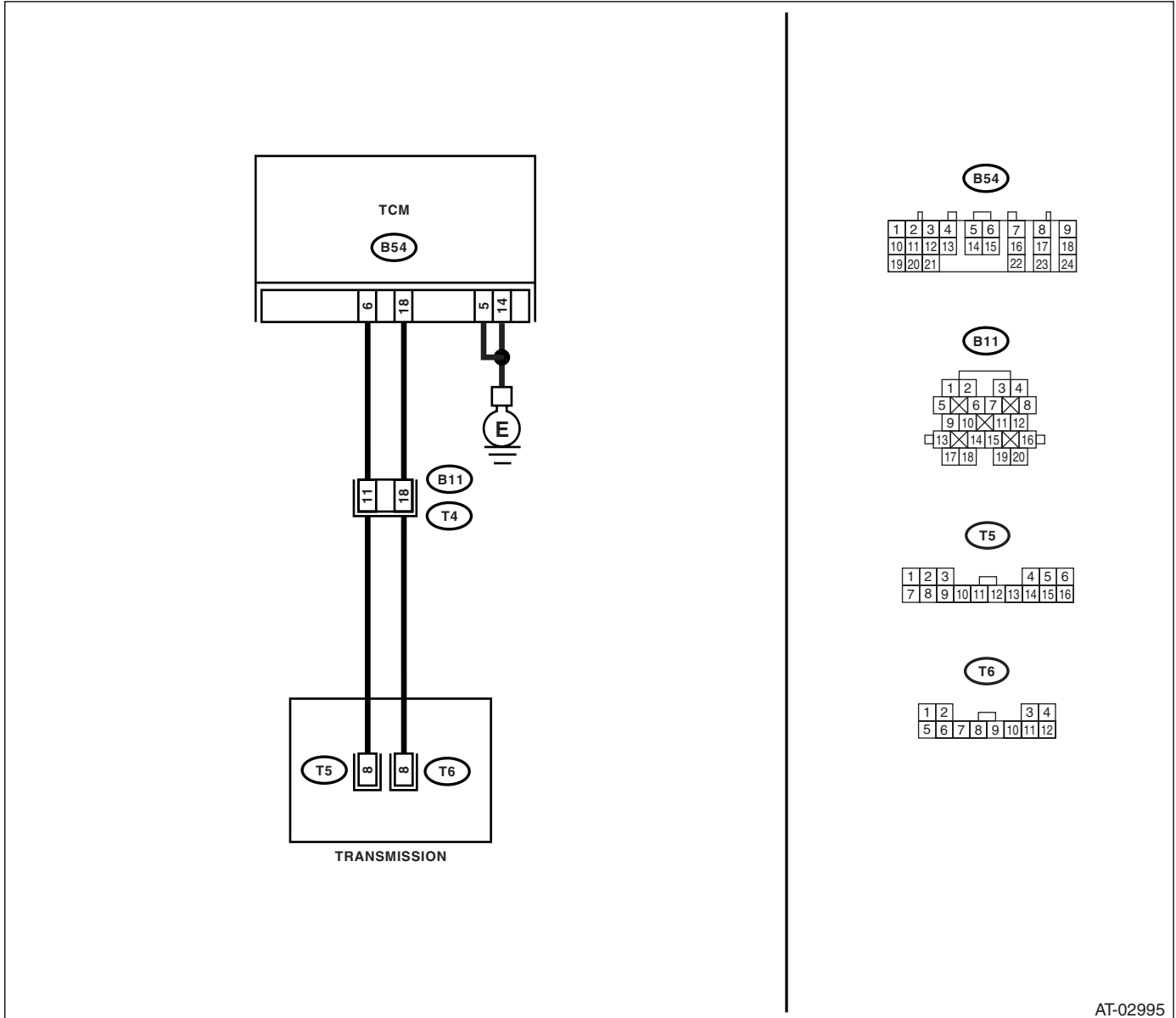

# Diagnostic Procedure with Diagnostic Trouble Code (DTC)

## AUTOMATIC TRANSMISSION (DIAGNOSTICS)

Step	Check	Yes	No
<b>1 CHECK HARNESS CONNECTOR BETWEEN TCM AND TRANSMISSION.</b> 1) Turn the ignition switch to OFF. 2) Disconnect the connectors from TCM and transmission. 3) Measure the resistance of harness between TCM connector and transmission connector.  <i>Connector &amp; terminal</i> <i>(B54) No. 18 — (B11) No. 18:</i> <i>(B54) No. 6 — (B11) No. 11:</i> <i>(B54) No. 5 — Chassis ground:</i> <i>(B54) No. 14 — Chassis ground:</i>	Is the resistance less than 1 $\Omega$ ?	Go to step 2.	Repair the open circuit of harness between TCM and transmission connector.
<b>2 CHECK HARNESS CONNECTOR BETWEEN TCM AND CHASSIS GROUND.</b> Measure the resistance of harness between TCM connector and chassis ground.  <i>Connector &amp; terminal</i> <i>(B54) No. 6 — Chassis ground:</i>	Is the resistance more than 1 M $\Omega$ ?	Go to step 3.	Repair the short circuit of harness between TCM and transmission connector.
<b>3 CHECK INPUT SIGNAL FOR TCM USING SUBARU SELECT MONITOR.</b> 1) Connect all the connectors. 2) Turn the ignition switch to ON. (Engine OFF) 3) Check input signal of I/C oil pressure SW.	Is OFF displayed?	Go to step 4.	Go to step 6.
<b>4 CHECK INPUT SIGNAL FOR TCM USING SUBARU SELECT MONITOR.</b> 1) Turn the ignition switch to OFF. 2) Turn the ignition switch to ON. (Engine ON) 3) Drive the vehicle on 4th speed of "D" range with checking current gear position using Subaru Select Monitor. 4) Check input signal of I/C oil pressure SW.	Is ON displayed?	Even if the SPORT indicator light blinks, the system is in normal condition. A temporary poor contact of connector or harness may be the cause. Repair the poor contact of harness in the solenoid output and oil pressure SW input.	Go to step 5.

# Diagnostic Procedure with Diagnostic Trouble Code (DTC)

AUTOMATIC TRANSMISSION (DIAGNOSTICS)

Step	Check	Yes	No
<p><b>5</b></p> <p><b>CHECK HARNESS CONNECTOR BETWEEN TRANSMISSION AND CONTROL VALVE BODY.</b></p> <ol style="list-style-type: none"> <li>1) Turn the ignition switch to OFF.</li> <li>2) Disconnect the connector from transmission.</li> <li>3) Remove the transmission connector from bracket.</li> <li>4) Lift-up the vehicle and place it on rigid racks.</li> </ol> <p>NOTE: Raise all wheels off floor.</p> <ol style="list-style-type: none"> <li>5) Drain the ATF.</li> </ol> <p><b>CAUTION:</b> <b>Do not drain ATF until it cools down.</b></p> <ol style="list-style-type: none"> <li>6) Remove the oil pan, and disconnect the control valve body connector.</li> <li>7) Measure the resistance between transmission connector and control valve body connector.</li> </ol> <p><b>Connector &amp; terminal</b> <b>(T4) No. 18 — (T6) No. 8:</b> <b>(T4) No. 11 — (T5) No. 8:</b></p>	<p>Is the resistance less than 1 <math>\Omega</math>?</p>	<p>Replace the control valve body. &lt;Ref. to 5AT-53, Control Valve Body.&gt;</p>	<p>Replace the transmission harness assembly.</p>
<p><b>6</b></p> <p><b>CHECK HARNESS CONNECTOR BETWEEN TRANSMISSION AND CONTROL VALVE BODY.</b></p> <ol style="list-style-type: none"> <li>1) Turn the ignition switch to OFF.</li> <li>2) Disconnect the connector from transmission.</li> <li>3) Remove the transmission connector from bracket.</li> <li>4) Lift-up the vehicle and place it on rigid racks.</li> </ol> <p>NOTE: Raise all wheels off floor.</p> <ol style="list-style-type: none"> <li>5) Drain the ATF.</li> </ol> <p><b>CAUTION:</b> <b>Do not drain ATF until it cools down.</b></p> <ol style="list-style-type: none"> <li>6) Remove the oil pan, and disconnect the control valve body connector.</li> <li>7) Check the insulation of transmission harness assembly.</li> </ol> <p><b>Connector &amp; terminal</b> <b>(T4) No. 11 — (T5) No. 13:</b></p>	<p>Is the resistance more than 1 <math>M\Omega</math>?</p>	<p>Replace the control valve body. &lt;Ref. to 5AT-53, Control Valve Body.&gt;</p>	<p>Replace the transmission harness assembly.</p>

# Diagnostic Procedure with Diagnostic Trouble Code (DTC)

AUTOMATIC TRANSMISSION (DIAGNOSTICS)

## U: DTC P0758 SHIFT SOLENOID “B” ELECTRICAL

### DTC DETECTING CONDITION:

Output signal circuit of input clutch solenoid is open or shorted.

### TROUBLE SYMPTOM:

Locked to 4th gear.

### WIRING DIAGRAM:

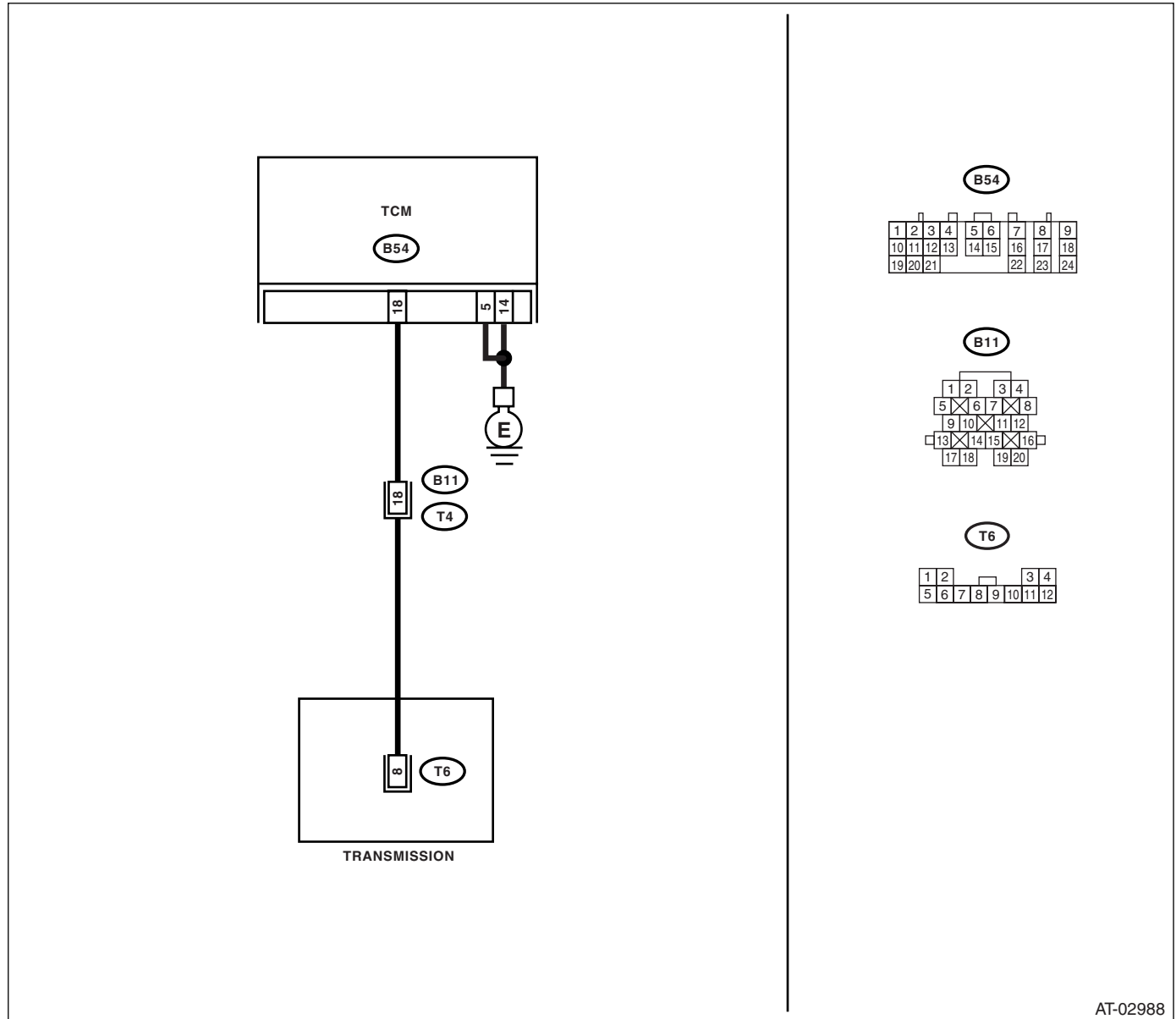

Step	Check	Yes	No
<b>1</b> <b>CHECK HARNESS CONNECTOR BETWEEN TCM AND TRANSMISSION.</b> 1) Turn the ignition switch to OFF. 2) Disconnect the connectors from TCM and transmission. 3) Measure the resistance of harness between TCM and transmission connector. <b>Connector &amp; terminal</b> (B54) No. 18 — (B11) No. 18: (B54) No. 5 — Chassis ground: (B54) No. 14 — Chassis ground:	Is the resistance less than 1 Ω?	Go to step 2.	Repair the open circuit of harness between TCM and transmission connector.



# Diagnostic Procedure with Diagnostic Trouble Code (DTC)

AUTOMATIC TRANSMISSION (DIAGNOSTICS)

Step	Check	Yes	No
<b>2 CHECK HARNESS CONNECTOR BETWEEN TCM AND BODY HARNESS.</b> Measure the resistance of harness between TCM connector and body harness. <i>Connector &amp; terminal</i> <i>(B54) No. 18 — Chassis ground:</i>	Is the resistance more than 1 M $\Omega$ ?	Go to step 3.	Repair the short circuit of harness between TCM and transmission connector.
<b>3 CHECK HARNESS CONNECTOR BETWEEN TRANSMISSION AND CONTROL VALVE BODY.</b> 1) Turn the ignition switch to OFF. 2) Disconnect the connector from transmission. 3) Remove the transmission connector from bracket. 4) Lift-up the vehicle and place it on rigid racks. NOTE: Raise all wheels off floor. 5) Drain the ATF. <b>CAUTION:</b> <b>Do not drain ATF until it cools down.</b> 6) Remove the oil pan, and disconnect the control valve body connector. 7) Measure the resistance between transmission connector and control valve body connector. <i>Connector &amp; terminal</i> <i>(T4) No. 18 — (T6) No. 8:</i>	Is the resistance less than 1 $\Omega$ ?	Go to step 4.	Repair the open circuit of harness between transmission connector and control valve body connector.
<b>4 CHECK HARNESS CONNECTOR BETWEEN TRANSMISSION AND CONTROL VALVE BODY.</b> Measure the resistance between chassis ground and control valve body connector. <i>Connector &amp; terminal</i> <i>(T6) No. 8 — Chassis ground:</i>	Is the resistance more than 1 M $\Omega$ ?	Go to step 5.	Repair the short circuit of harness between transmission connector and control valve body connector.
<b>5 CHECK INPUT CLUTCH SOLENOID.</b> Measure the resistance between transmission ground and control valve body connector. <i>Connector &amp; terminal</i> <i>(T6) No. 8 — Transmission ground:</i>	Is the resistance between 3 — 9 $\Omega$ ?	Go to step 6.	Replace the control valve body. <Ref. to 5AT-53, Control Valve Body.>
<b>6 CHECK POOR CONTACT.</b> Check that there are no poor contact in TCM connector, transmission connector and control valve body connector.	Is there any loosing terminal, entering foreign matter, damaging connector body?	Repair the poor contact.	Go to step 7.
<b>7 CHECK AFTER REPAIR.</b> 1) Perform the clear memory mode. 2) Drive for a while, read the DTC, and check that there is no faulty.	Is DTC displayed?	Replace the TCM. <Ref. to 5AT-56, Transmission Control Module (TCM).>	Temporary poor contact or open circuit occurs. Recheck that the harness connector has no faulty.

# Diagnostic Procedure with Diagnostic Trouble Code (DTC)

AUTOMATIC TRANSMISSION (DIAGNOSTICS)

## V: DTC P0761 SHIFT SOLENOID "C" PERFORMANCE OR STUCK OFF

### DTC DETECTING CONDITION:

Output signal value of high & low reverse clutch solenoid and oil pressure does not match.

### TROUBLE SYMPTOM:

Locked to 4th gear.

### WIRING DIAGRAM:

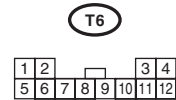
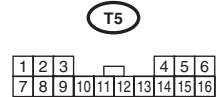
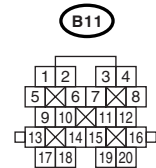
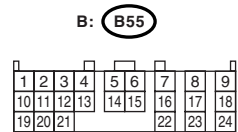
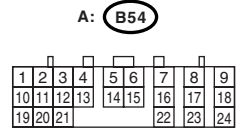
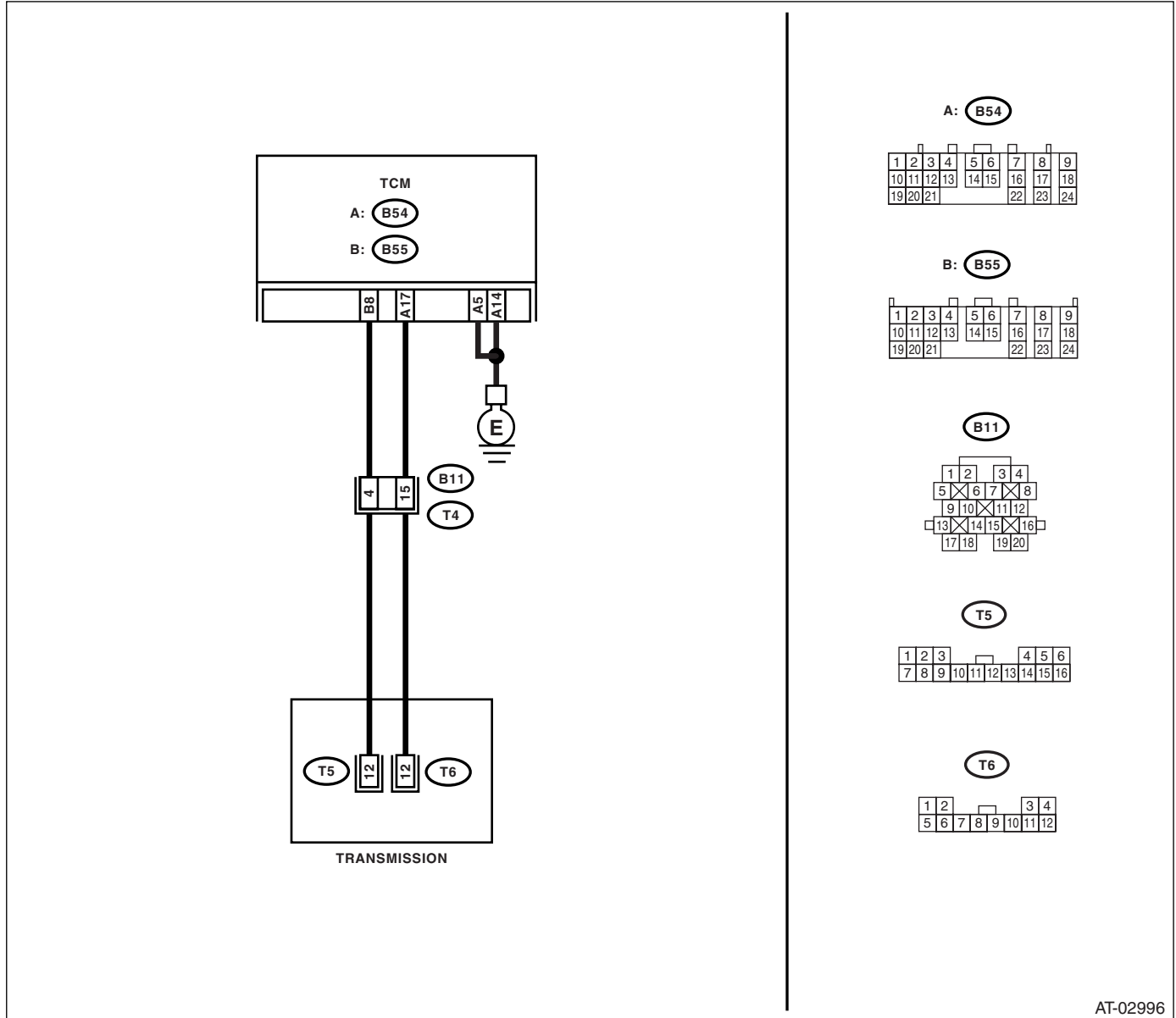

AT-02996

# Diagnostic Procedure with Diagnostic Trouble Code (DTC)

AUTOMATIC TRANSMISSION (DIAGNOSTICS)

Step	Check	Yes	No
<b>1 CHECK HARNESS CONNECTOR BETWEEN TCM AND TRANSMISSION.</b> 1) Turn the ignition switch to OFF. 2) Disconnect the connectors from TCM and transmission. 3) Measure the resistance of harness between TCM and transmission connector. <b>Connector &amp; terminal</b> <b>(B54) No. 17 — (B11) No. 15:</b> <b>(B55) No. 8 — (B11) No. 4:</b> <b>(B54) No. 5 — Chassis ground:</b> <b>(B54) No. 14 — Chassis ground:</b>	Is the resistance less than 1 $\Omega$ ?	Go to step 2.	Repair the open circuit of harness between TCM and transmission connector.
<b>2 CHECK HARNESS CONNECTOR BETWEEN TCM AND CHASSIS GROUND.</b> Measure the resistance of harness between TCM connector and chassis ground. <b>Connector &amp; terminal</b> <b>(B55) No. 8 — Chassis ground:</b>	Is the resistance more than 1 $M\Omega$ ?	Go to step 3.	Repair the short circuit of harness between TCM and transmission connector.
<b>3 CHECK INPUT SIGNAL FOR TCM USING SUBARU SELECT MONITOR.</b> 1) Connect all the connectors. 2) Turn the ignition switch to ON. (Engine OFF) 3) Check the input signal of the H&LR/C oil pressure SW.	Is OFF displayed?	Go to step 4.	Go to step 6.
<b>4 CHECK INPUT SIGNAL FOR TCM USING SUBARU SELECT MONITOR.</b> 1) Turn the ignition switch to OFF. 2) Turn the ignition switch to ON. (Engine ON) 3) Shift to "D" range and brake ON (1st) with checking current gear position using Subaru Select Monitor. 4) Check the input signal of the H&LR/C oil pressure SW.	Is ON displayed?	Even if the SPORT indicator light blinks, the system is in normal condition. A temporary poor contact of connector or harness may be the cause. Repair the poor contact of harness in the solenoid output and oil pressure SW input.	Go to step 5.

# Diagnostic Procedure with Diagnostic Trouble Code (DTC)

## AUTOMATIC TRANSMISSION (DIAGNOSTICS)

Step	Check	Yes	No
<p><b>5</b></p> <p><b>CHECK HARNESS CONNECTOR BETWEEN TRANSMISSION AND CONTROL VALVE BODY.</b></p> <p>1) Turn the ignition switch to OFF.                      2) Disconnect the connector from transmission.                      3) Remove the transmission connector from bracket.                      4) Lift-up the vehicle and place it on rigid racks.</p> <p>NOTE:                      Raise all wheels off floor.                      5) Drain the ATF.</p> <p><b>CAUTION:</b>  <b>Do not drain ATF until it cools down.</b></p> <p>6) Remove the oil pan, and disconnect the control valve body connector.                      7) Measure the resistance between transmission connector and control valve body connector.</p> <p><b>Connector &amp; terminal</b>  <i>(T4) No. 15 — (T6) No. 12:</i>  <i>(T4) No. 4 — (T5) No. 12:</i></p>	<p>Is the resistance less than 1 <math>\Omega</math>?</p>	<p>Replace the control valve body.                      &lt;Ref. to 5AT-53, Control Valve Body.&gt;</p>	<p>Replace the transmission harness assembly.</p>
<p><b>6</b></p> <p><b>CHECK HARNESS CONNECTOR BETWEEN TRANSMISSION AND CONTROL VALVE BODY.</b></p> <p>1) Turn the ignition switch to OFF.                      2) Disconnect the connector from transmission.                      3) Remove the transmission connector from bracket.                      4) Lift-up the vehicle and place it on rigid racks.</p> <p>NOTE:                      Raise all wheels off floor.                      5) Drain the ATF.</p> <p><b>CAUTION:</b>  <b>Do not drain ATF until it cools down.</b></p> <p>6) Remove the oil pan, and disconnect the control valve body connector.                      7) Check the insulation of transmission harness assembly.</p> <p><b>Connector &amp; terminal</b>  <i>(T4) No. 4 — (T5) No. 13:</i></p>	<p>Is the resistance more than 1 <math>M\Omega</math>?</p>	<p>Replace the control valve body.                      &lt;Ref. to 5AT-53, Control Valve Body.&gt;</p>	<p>Replace the transmission harness assembly.</p>

# Diagnostic Procedure with Diagnostic Trouble Code (DTC)

AUTOMATIC TRANSMISSION (DIAGNOSTICS)

## W: DTC P0763 SHIFT SOLENOID "C" ELECTRICAL

### DTC DETECTING CONDITION:

Output signal circuit of high & low reverse clutch solenoid is open or shorted.

### TROUBLE SYMPTOM:

Locked to 4th gear.

### WIRING DIAGRAM:

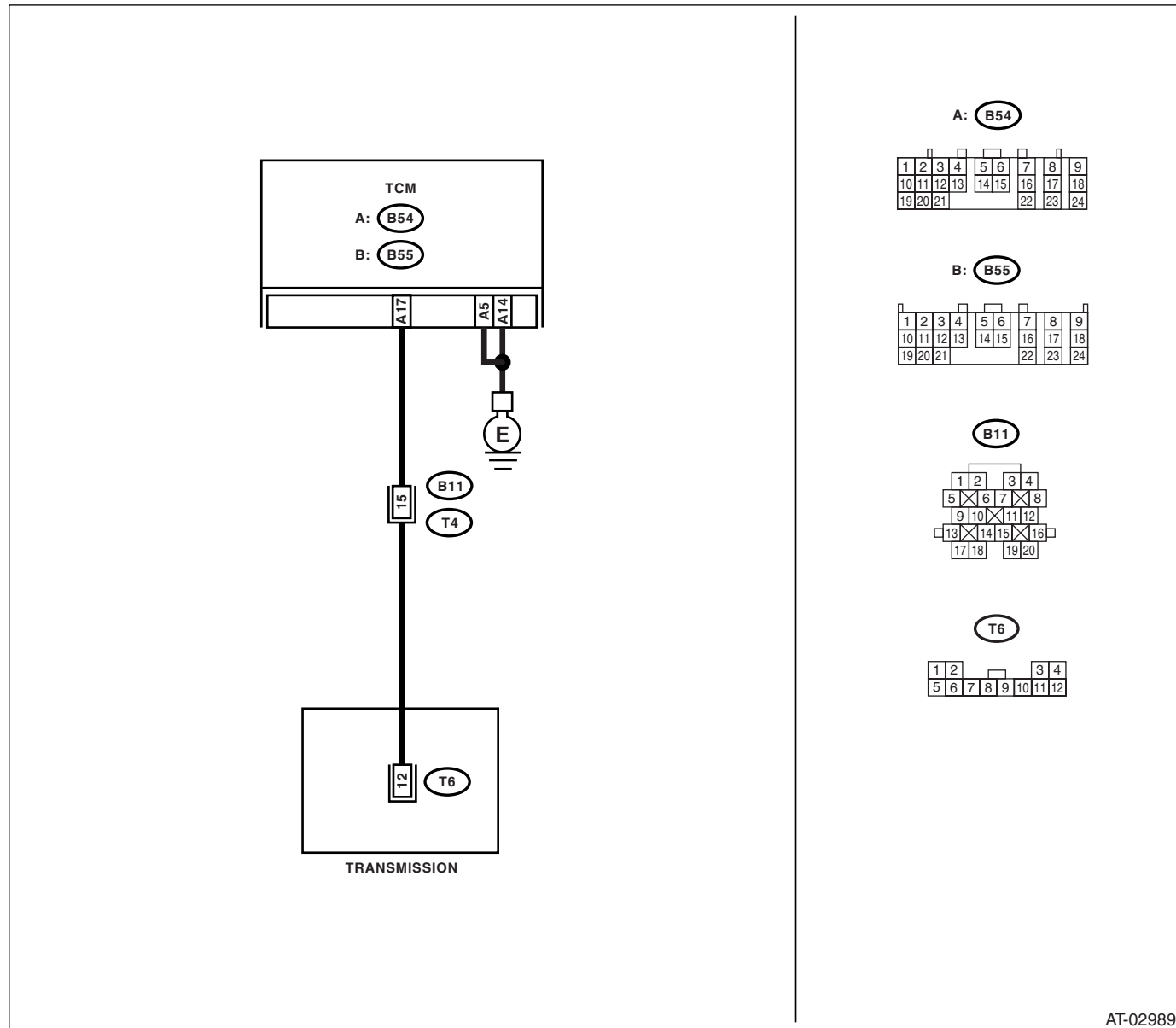

AT-02989

Step	Check	Yes	No
<b>1</b> <b>CHECK HARNESS CONNECTOR BETWEEN TCM AND TRANSMISSION.</b> 1) Turn the ignition switch to OFF. 2) Disconnect the connectors from TCM and transmission. 3) Measure the resistance of harness between TCM and transmission connector. <b>Connector &amp; terminal</b> (B54) No. 17 — (B11) No. 15: (B54) No. 5 — Chassis ground: (B54) No. 14 — Chassis ground:	Is the resistance less than 1 Ω?	Go to step 2.	Repair the open circuit of harness between TCM connector and transmission connector.

## Diagnostic Procedure with Diagnostic Trouble Code (DTC)

### AUTOMATIC TRANSMISSION (DIAGNOSTICS)

Step	Check	Yes	No
<b>2 CHECK HARNESS CONNECTOR BETWEEN TCM AND CHASSIS GROUND.</b> Measure the resistance of harness between TCM connector and chassis ground. <i><b>Connector &amp; terminal</b></i> <i><b>(B54) No. 17 — Chassis ground:</b></i>	Is the resistance more than 1 M $\Omega$ ?	Go to step 3.	Repair the short circuit of harness between TCM connector and transmission connector.
<b>3 CHECK HARNESS CONNECTOR BETWEEN TRANSMISSION AND CONTROL VALVE BODY.</b> 1) Turn the ignition switch to OFF. 2) Disconnect the connector from transmission. 3) Remove the transmission connector from bracket. 4) Lift-up the vehicle and place it on rigid racks. NOTE: Raise all wheels off floor. 5) Drain the ATF. <b>CAUTION:</b> <b>Do not drain ATF until it cools down.</b> 6) Remove the oil pan, and disconnect the control valve body connector. 7) Measure the resistance between transmission connector and control valve body connector. <i><b>Connector &amp; terminal</b></i> <i><b>(T4) No. 15 — (T6) No. 12:</b></i>	Is the resistance less than 1 $\Omega$ ?	Go to step 4.	Repair the open circuit of harness between transmission connector and control valve body connector.
<b>4 CHECK HARNESS CONNECTOR BETWEEN TRANSMISSION AND CONTROL VALVE BODY.</b> Measure the resistance of harness connector between control valve body connector and chassis ground. <i><b>Connector &amp; terminal</b></i> <i><b>(T6) No. 12 — Chassis ground:</b></i>	Is the resistance more than 1 M $\Omega$ ?	Go to step 5.	Repair the open circuit of harness between control valve body connector and transmission ground.
<b>5 CHECK HIGH &amp; LOW REVERSE CLUTCH SOLENOID.</b> Measure the resistance between transmission ground and control valve body connector. <i><b>Connector &amp; terminal</b></i> <i><b>(T6) No. 12 — Transmission ground:</b></i>	Is the resistance between 3 — 9 $\Omega$ ?	Go to step 6.	Replace the control valve body. <Ref. to 5AT-53, Control Valve Body.>
<b>6 CHECK POOR CONTACT.</b> Check that there are no poor contact in TCM connector, transmission connector and control valve body connector.	Is there any loosing terminal, entering foreign matter, damaging connector body?	Repair the poor contact.	Go to step 7.
<b>7 CHECK AFTER REPAIR.</b> 1) Perform the clear memory mode. 2) Drive for a while, read the DTC, and check that there is no faulty.	Is DTC displayed?	Replace the TCM. <Ref. to 5AT-56, Transmission Control Module (TCM).>	Temporary poor contact or open circuit occurs. Recheck that the harness connector has no faulty.

# Diagnostic Procedure with Diagnostic Trouble Code (DTC)

AUTOMATIC TRANSMISSION (DIAGNOSTICS)

## X: DTC P0766 SHIFT SOLENOID "D" PERFORMANCE OR STUCK OFF

### DTC DETECTING CONDITION:

Output signal value of direct clutch solenoid and oil pressure does not match.

### TROUBLE SYMPTOM:

Locked to 4th gear.

### WIRING DIAGRAM:

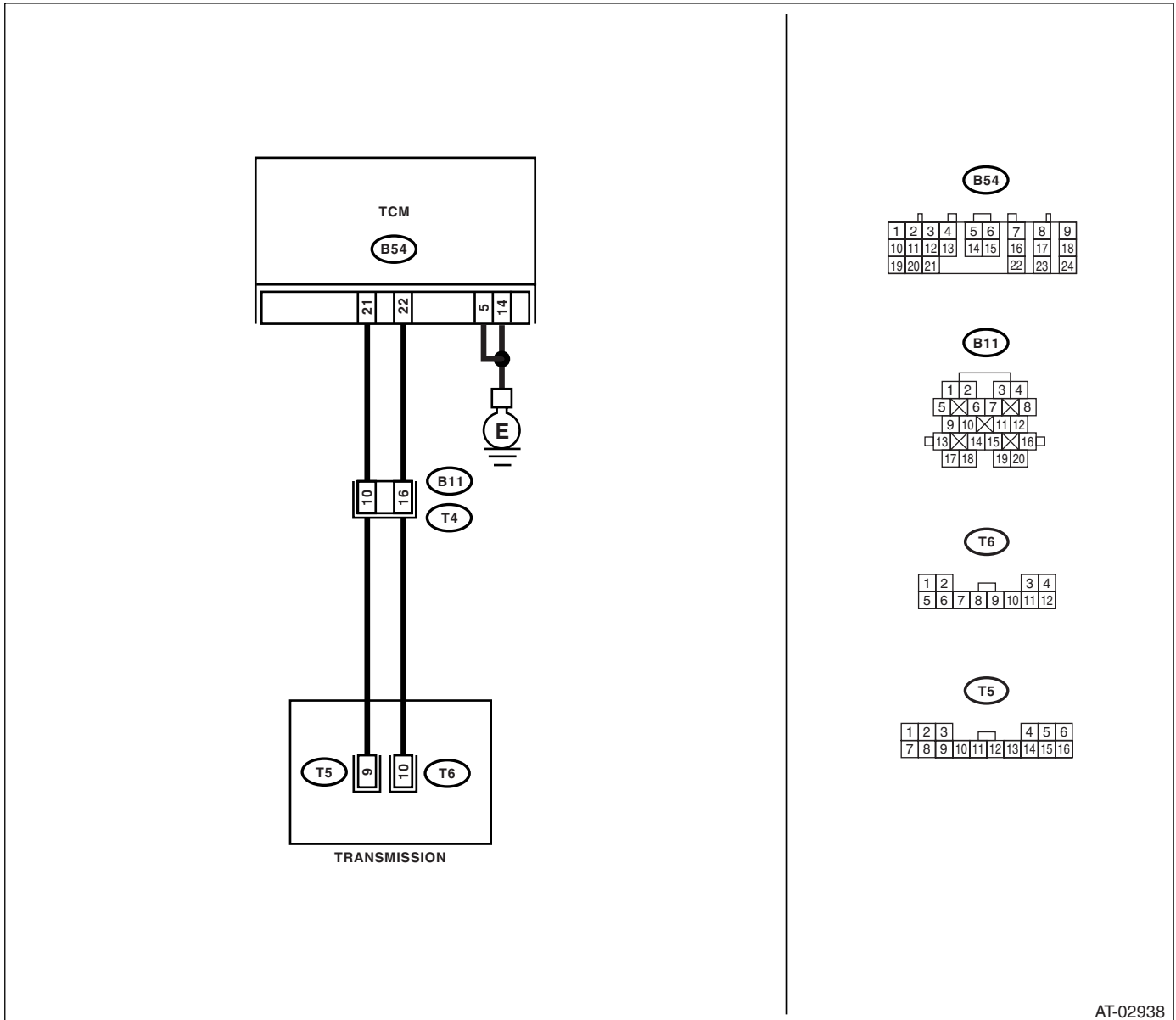

AT-02938

## Diagnostic Procedure with Diagnostic Trouble Code (DTC)

### AUTOMATIC TRANSMISSION (DIAGNOSTICS)

Step	Check	Yes	No
<b>1 CHECK HARNESS CONNECTOR BETWEEN TCM AND TRANSMISSION.</b> 1) Turn the ignition switch to OFF. 2) Disconnect the connectors from TCM and transmission. 3) Measure the resistance of harness between TCM and transmission connector. <i>Connector &amp; terminal</i> (B54) No. 22 — (B11) No. 16: (B54) No. 21 — (B11) No. 10: (B54) No. 5 — Chassis ground: (B54) No. 14 — Chassis ground:	Is the resistance less than 1 $\Omega$ ?	Go to step 2.	Repair the open circuit of harness between TCM and transmission connector.
<b>2 CHECK HARNESS CONNECTOR BETWEEN TCM AND BODY HARNESS.</b> Measure the resistance of harness between TCM connector and body harness. <i>Connector &amp; terminal</i> (B54) No. 21 — Chassis ground:	Is the resistance more than 1 $M\Omega$ ?	Go to step 3.	Repair the short circuit of harness between TCM and transmission connector.
<b>3 CHECK INPUT SIGNAL FOR TCM USING SUBARU SELECT MONITOR.</b> 1) Connect all the connectors. 2) Turn the ignition switch to ON. (Engine OFF) 3) Check input signal of D/C oil pressure SW.	Is OFF displayed?	Go to step 4.	Go to step 6.
<b>4 CHECK INPUT SIGNAL FOR TCM USING SUBARU SELECT MONITOR.</b> 1) Turn the ignition switch to OFF. 2) Turn the ignition switch to ON. (Engine ON) 3) Shift to 2nd speed of manual mode and brake ON with checking current gear position using Subaru Select Monitor. 4) Check input signal of D/C oil pressure SW.	Is ON displayed?	Even if the SPORT indicator light blinks, the system is in normal condition. A temporary poor contact of connector or harness may be the cause. Repair the poor contact of harness in the solenoid output and oil pressure SW input.	Go to step 5.



# Diagnostic Procedure with Diagnostic Trouble Code (DTC)

AUTOMATIC TRANSMISSION (DIAGNOSTICS)

Step	Check	Yes	No
<p><b>5</b></p> <p><b>CHECK HARNESS CONNECTOR BETWEEN TRANSMISSION AND CONTROL VALVE BODY.</b></p> <ol style="list-style-type: none"> <li>1) Turn the ignition switch to OFF.</li> <li>2) Disconnect the connector from transmission.</li> <li>3) Remove the transmission connector from bracket.</li> <li>4) Lift-up the vehicle and place it on rigid racks.</li> </ol> <p>NOTE: Raise all wheels off floor.</p> <ol style="list-style-type: none"> <li>5) Drain the ATF.</li> </ol> <p><b>CAUTION:</b> <b>Do not drain ATF until it cools down.</b></p> <ol style="list-style-type: none"> <li>6) Remove the oil pan, and disconnect the control valve body connector.</li> <li>7) Measure the resistance between transmission connector and control valve body connector.</li> </ol> <p><b>Connector &amp; terminal</b> <b>(T4) No. 16 — (T6) No. 10:</b> <b>(T4) No. 10 — (T5) No. 9:</b></p>	<p>Is the resistance less than 1 <math>\Omega</math>?</p>	<p>Replace the control valve body. &lt;Ref. to 5AT-53, Control Valve Body.&gt;</p>	<p>Replace the transmission harness assembly.</p>
<p><b>6</b></p> <p><b>CHECK HARNESS CONNECTOR BETWEEN TRANSMISSION AND CONTROL VALVE BODY.</b></p> <ol style="list-style-type: none"> <li>1) Turn the ignition switch to OFF.</li> <li>2) Disconnect the connector from transmission.</li> <li>3) Remove the transmission connector from bracket.</li> <li>4) Lift-up the vehicle and place it on rigid racks.</li> </ol> <p>NOTE: Raise all wheels off floor.</p> <ol style="list-style-type: none"> <li>5) Drain the ATF.</li> </ol> <p><b>CAUTION:</b> <b>Do not drain ATF until it cools down.</b></p> <ol style="list-style-type: none"> <li>6) Remove the oil pan, and disconnect the control valve body connector.</li> <li>7) Check the insulation of transmission harness assembly.</li> </ol> <p><b>Connector &amp; terminal</b> <b>(T4) No. 10 — (T5) No. 13:</b></p>	<p>Is the resistance more than 1 <math>M\Omega</math>?</p>	<p>Replace the control valve body. &lt;Ref. to 5AT-53, Control Valve Body.&gt;</p>	<p>Replace the transmission harness assembly.</p>

# Diagnostic Procedure with Diagnostic Trouble Code (DTC)

AUTOMATIC TRANSMISSION (DIAGNOSTICS)

## Y: DTC P0768 SOLENOID "D" ELECTRICAL

### DTC DETECTING CONDITION:

The output signal circuit of direct clutch solenoid is open or shorted.

### TROUBLE SYMPTOM:

Locked to 4th gear.

### WIRING DIAGRAM:

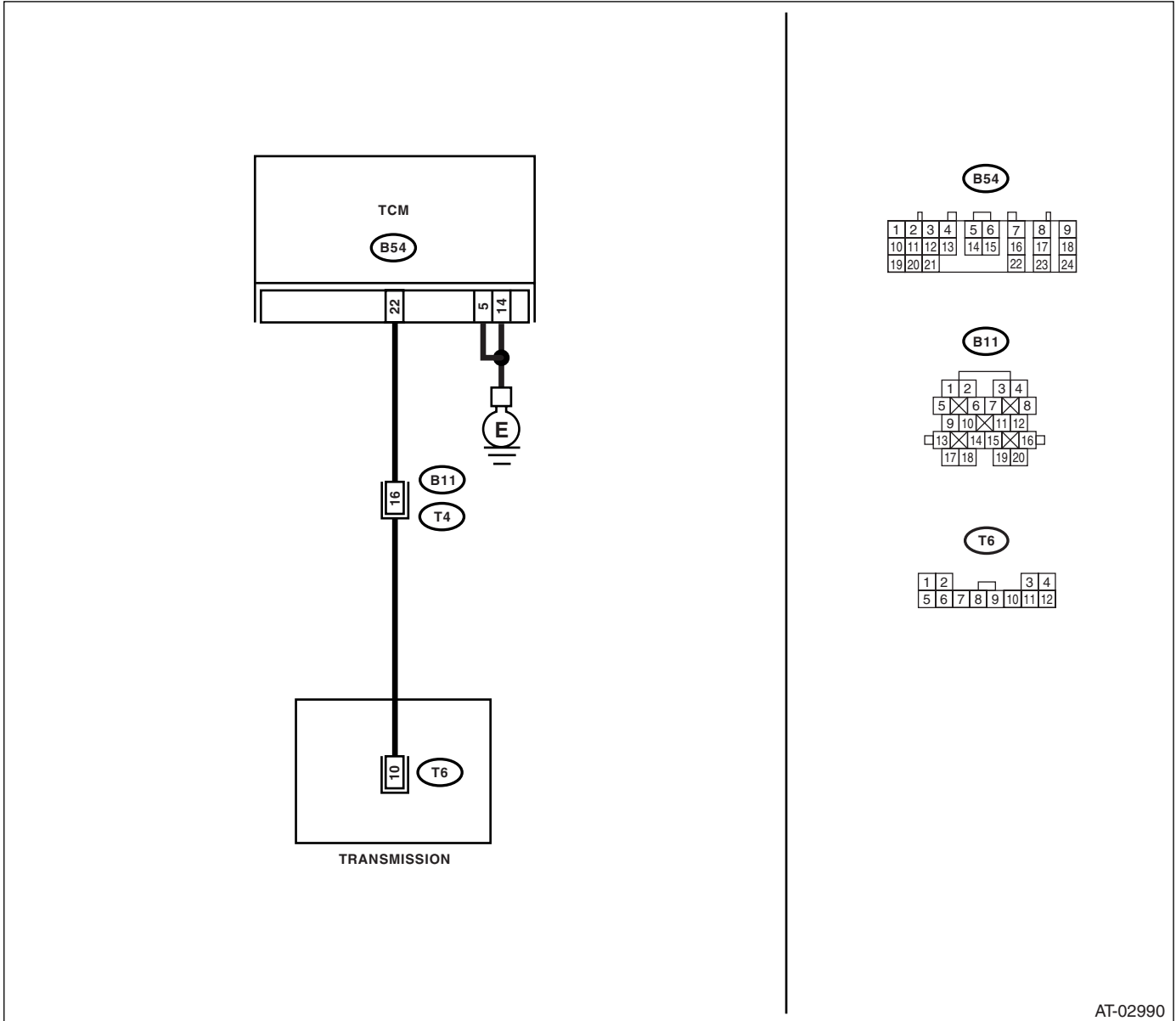

Step	Check	Yes	No
<b>1 CHECK HARNESS CONNECTOR BETWEEN TCM AND TRANSMISSION.</b> 1) Turn the ignition switch to OFF. 2) Disconnect the connectors from TCM and transmission. 3) Measure the resistance of harness between TCM and transmission connector. <b>Connector &amp; terminal</b> (B54) No. 22 — (B11) No. 16: (B54) No. 5 — Chassis ground: (B54) No. 14 — Chassis ground:	Is the resistance less than 1 Ω?	Go to step 2.	Repair the open circuit of harness between TCM connector and transmission connector.

# Diagnostic Procedure with Diagnostic Trouble Code (DTC)

AUTOMATIC TRANSMISSION (DIAGNOSTICS)

Step	Check	Yes	No
<b>2 CHECK HARNESS CONNECTOR BETWEEN TCM AND CHASSIS GROUND.</b> Measure the resistance of harness between TCM connector and chassis ground. <i>Connector &amp; terminal</i> <i>(B54) No. 22 — Chassis ground:</i>	Is the resistance more than 1 M $\Omega$ ?	Go to step 3.	Repair the short circuit of harness between TCM connector and transmission connector.
<b>3 CHECK HARNESS CONNECTOR BETWEEN TRANSMISSION AND CONTROL VALVE BODY.</b> 1) Turn the ignition switch to OFF. 2) Disconnect the connector from transmission. 3) Remove the transmission connector from bracket. 4) Lift-up the vehicle and place it on rigid racks. NOTE: Raise all wheels off floor. 5) Drain the ATF. <b>CAUTION:</b> <b>Do not drain ATF until it cools down.</b> 6) Remove the oil pan, and disconnect the control valve body connector. 7) Measure the resistance between transmission connector and control valve body connector. <i>Connector &amp; terminal</i> <i>(T4) No. 16 — (T6) No. 10:</i>	Is the resistance less than 1 $\Omega$ ?	Go to step 4.	Repair the open circuit of harness between transmission connector and control valve body connector.
<b>4 CHECK HARNESS CONNECTOR BETWEEN TRANSMISSION AND CONTROL VALVE BODY.</b> Measure the resistance between chassis ground and control valve body connector. <i>Connector &amp; terminal</i> <i>(T6) No. 10 — Chassis ground:</i>	Is the resistance more than 1 M $\Omega$ ?	Go to step 5.	Repair the short circuit of harness between control valve body connector and transmission ground.
<b>5 CHECK DIRECT CLUTCH SOLENOID.</b> Measure the resistance of harness connector between control valve body connector and transmission ground. <i>Connector &amp; terminal</i> <i>(T6) No. 10 — Transmission ground:</i>	Is the resistance between 3 — 9 $\Omega$ ?	Go to step 6.	Replace the control valve body. <Ref. to 5AT-53, Control Valve Body.>
<b>6 CHECK POOR CONTACT.</b> Check that there are no poor contact in TCM connector, transmission connector and control valve body connector.	Is there any loosing terminal, entering foreign matter, damaging connector body?	Repair the poor contact.	Go to step 7.
<b>7 CHECK AFTER REPAIR.</b> 1) Perform the clear memory mode. 2) Drive for a while, read the DTC, and check that there is no faulty.	Is DTC displayed?	Replace the TCM. <Ref. to 5AT-56, Transmission Control Module (TCM).>	Temporary poor contact or open circuit occurs. Recheck that the harness connector has no faulty.

# Diagnostic Procedure with Diagnostic Trouble Code (DTC)

AUTOMATIC TRANSMISSION (DIAGNOSTICS)

## Z: DTC P0771 SHIFT SOLENOID “E” PERFORMANCE OR STUCK OFF

### DTC DETECTING CONDITION:

Output signal value of low coast brake solenoid and oil pressure does not match.

### TROUBLE SYMPTOM:

- Locked to 2nd gear.
- Engine brake does not function at 1st or 2nd of manual mode.

### WIRING DIAGRAM:

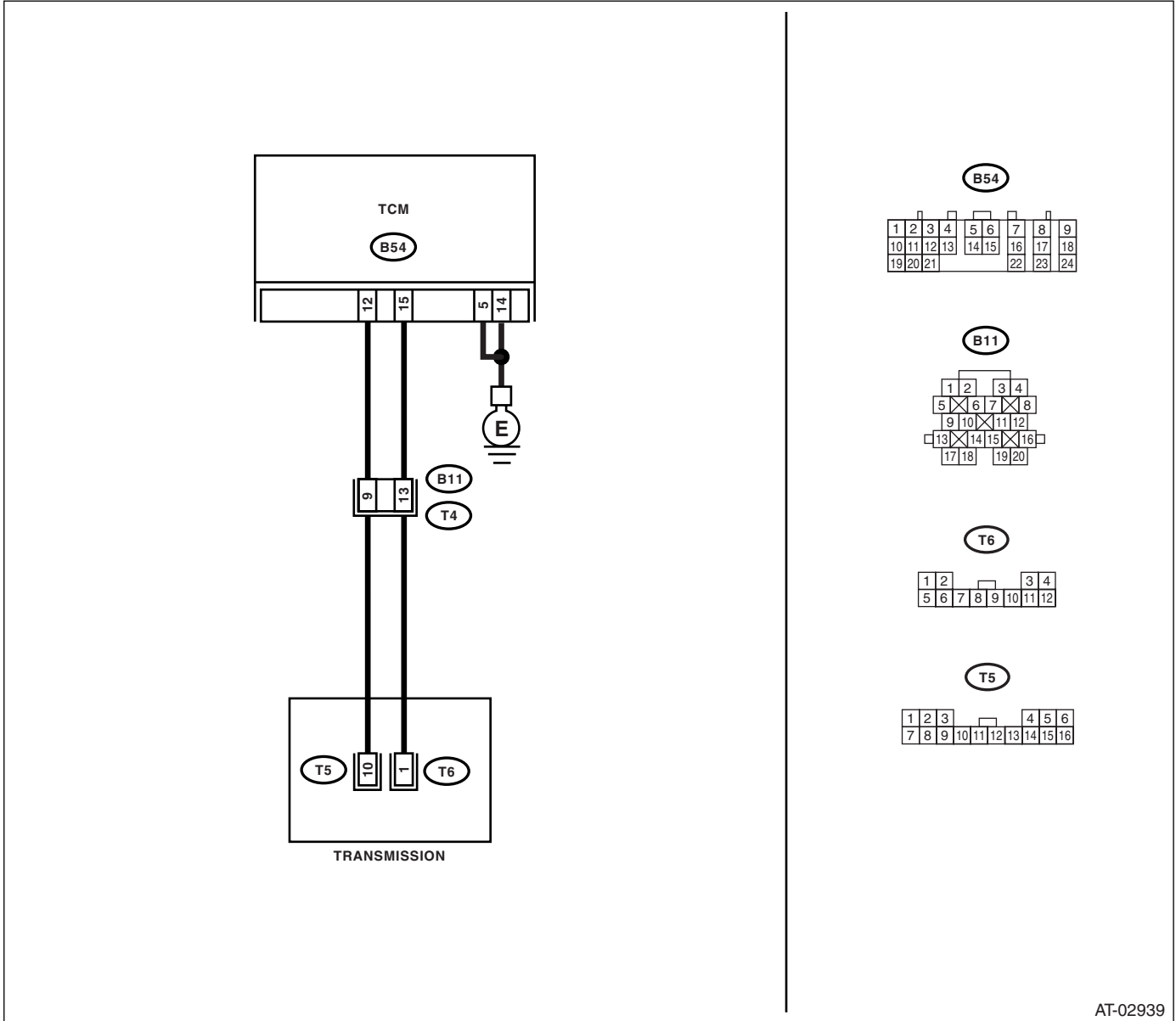

AT-02939

# Diagnostic Procedure with Diagnostic Trouble Code (DTC)

AUTOMATIC TRANSMISSION (DIAGNOSTICS)

Step	Check	Yes	No
<b>1 CHECK HARNESS CONNECTOR BETWEEN TCM AND TRANSMISSION.</b> 1) Turn the ignition switch to OFF. 2) Disconnect the connectors from TCM and transmission. 3) Measure the resistance of harness between TCM and transmission connector. <b>Connector &amp; terminal</b> <b>(B54) No. 15 — (B11) No. 13:</b> <b>(B54) No. 12 — (B11) No. 9:</b> <b>(B54) No. 5 — Chassis ground:</b> <b>(B54) No. 14 — Chassis ground:</b>	Is the resistance less than 1 $\Omega$ ?	Go to step 2.	Repair the open circuit of harness between TCM and transmission connector.
<b>2 CHECK HARNESS CONNECTOR BETWEEN TCM AND CHASSIS GROUND.</b> Measure the resistance between TCM connector and chassis ground. <b>Connector &amp; terminal</b> <b>(B54) No. 12 — Chassis ground:</b>	Is the resistance more than 1 $M\Omega$ ?	Go to step 3.	Repair the short circuit of harness between TCM and transmission connector.
<b>3 CHECK INPUT SIGNAL FOR TCM USING SUBARU SELECT MONITOR.</b> 1) Connect all the connectors. 2) Turn the ignition switch to ON. (Engine OFF) 3) Check input signal of LC/B oil pressure SW.	Is OFF displayed?	Go to step 4.	Go to step 6.
<b>4 CHECK INPUT SIGNAL FOR TCM USING SUBARU SELECT MONITOR.</b> 1) Turn the ignition switch to OFF. 2) Turn the ignition switch to ON. (Engine ON) 3) Drive the vehicle on 2nd speed of manual mode 15 km/h (9 MPH) with checking current gear position using Subaru Select Monitor. 4) Check input signal of LC/B oil pressure SW.	Is ON displayed?	Even if the SPORT indicator light blinks, the system is in normal condition. A temporary poor contact of connector or harness may be the cause. Repair the poor contact of harness in the solenoid output and oil pressure SW input.	Go to step 5.

## Diagnostic Procedure with Diagnostic Trouble Code (DTC)

### AUTOMATIC TRANSMISSION (DIAGNOSTICS)

Step	Check	Yes	No
<p><b>5</b></p> <p><b>CHECK HARNESS CONNECTOR BETWEEN TRANSMISSION AND CONTROL VALVE BODY.</b></p> <p>1) Turn the ignition switch to OFF.                  2) Disconnect the connector from transmission.                  3) Remove the transmission connector from bracket.                  4) Lift-up the vehicle and place it on rigid racks.</p> <p>NOTE:                  Raise all wheels off floor.                  5) Drain the ATF.</p> <p><b>CAUTION:</b>  <b>Do not drain ATF until it cools down.</b></p> <p>6) Remove the oil pan, and disconnect the control valve body connector.                  7) Measure the resistance between transmission connector and control valve body connector.</p> <p><b>Connector &amp; terminal</b>  <i>(T4) No. 13 — (T6) No. 1:</i>  <i>(T4) No. 9 — (T5) No. 10:</i></p>	<p>Is the resistance less than 1 <math>\Omega</math>?</p>	<p>Replace the control valve body.                  &lt;Ref. to 5AT-53, Control Valve Body.&gt;</p>	<p>Replace the transmission harness assembly.</p>
<p><b>6</b></p> <p><b>CHECK HARNESS CONNECTOR BETWEEN TRANSMISSION AND CONTROL VALVE BODY.</b></p> <p>1) Turn the ignition switch to OFF.                  2) Disconnect the connector from transmission.                  3) Remove the transmission connector from bracket.                  4) Lift-up the vehicle and place it on rigid racks.</p> <p>NOTE:                  Raise all wheels off floor.                  5) Drain the ATF.</p> <p><b>CAUTION:</b>  <b>Do not drain ATF until it cools down.</b></p> <p>6) Remove the oil pan, and disconnect the control valve body connector.                  7) Check the insulation of transmission harness assembly.</p> <p><b>Connector &amp; terminal</b>  <i>(T4) No. 9 — (T5) No. 13:</i></p>	<p>Is the resistance more than 1 M<math>\Omega</math>?</p>	<p>Replace the control valve body.                  &lt;Ref. to 5AT-53, Control Valve Body.&gt;</p>	<p>Repair the short circuit of harness between transmission connector and control valve body connector.</p>

# Diagnostic Procedure with Diagnostic Trouble Code (DTC)

AUTOMATIC TRANSMISSION (DIAGNOSTICS)

## AA:DTC P0773 SHIFT SOLENOID "E" ELECTRICAL

### DTC DETECTING CONDITION:

Output signal circuit of low coast brake solenoid is open or shorted.

### TROUBLE SYMPTOM:

- Locked to 2nd gear.
- Engine brake does not function at 1st or 2nd of manual mode.

### WIRING DIAGRAM:

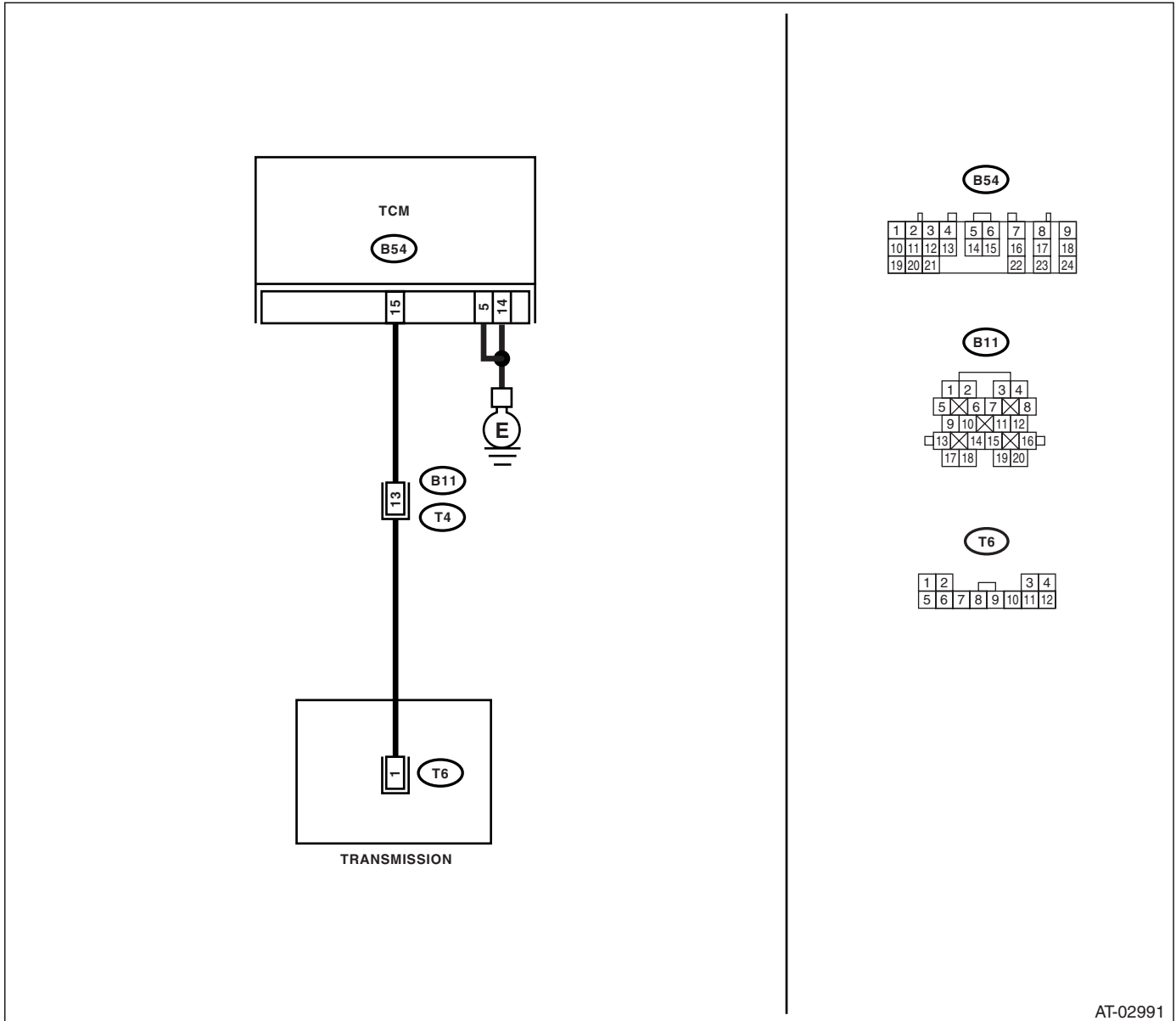

AT-02991

# Diagnostic Procedure with Diagnostic Trouble Code (DTC)

## AUTOMATIC TRANSMISSION (DIAGNOSTICS)

Step	Check	Yes	No
1	<b>CHECK DTC OF TCM.</b>	Perform the diagnosis according to DTC.	Go to step 2.
2	<b>CHECK HARNESS CONNECTOR BETWEEN TCM AND TRANSMISSION.</b> 1) Turn the ignition switch to OFF. 2) Disconnect the connectors from TCM and transmission. 3) Measure the resistance of harness between TCM and transmission connector. <b>Connector &amp; terminal</b> <b>(B54) No. 15 — (B11) No. 13:</b> <b>(B54) No. 5 — Chassis ground:</b> <b>(B54) No. 14 — Chassis ground:</b>	Go to step 3.	Repair the open circuit of harness between TCM connector and transmission connector.
3	<b>CHECK HARNESS CONNECTOR BETWEEN TCM AND BODY HARNESS.</b> Measure the resistance of harness between TCM connector and body harness. <b>Connector &amp; terminal</b> <b>(B54) No. 15 — Chassis ground:</b>	Go to step 4.	Repair the short circuit of harness between TCM connector and transmission connector.
4	<b>CHECK HARNESS CONNECTOR BETWEEN TRANSMISSION AND CONTROL VALVE BODY.</b> 1) Turn the ignition switch to OFF. 2) Disconnect the connector from transmission. 3) Remove the transmission connector from bracket. 4) Lift-up the vehicle and place it on rigid racks. NOTE: Raise all wheels off floor. 5) Drain the ATF. <b>CAUTION:</b> <b>Do not drain ATF until it cools down.</b> 6) Remove the oil pan, and disconnect the control valve body connector. 7) Measure the resistance between transmission connector and control valve body connector. <b>Connector &amp; terminal</b> <b>(T4) No. 13 — (T6) No. 1:</b>	Go to step 5.	Repair the open circuit of harness between transmission connector and control valve body connector.
5	<b>CHECK HARNESS CONNECTOR BETWEEN TRANSMISSION AND CONTROL VALVE BODY.</b> Measure the resistance between chassis ground and control valve body connector. <b>Connector &amp; terminal</b> <b>(T6) No. 1 — Chassis ground:</b>	Go to step 6.	Repair the short circuit of harness between control valve body connector and transmission ground.
6	<b>CHECK LOW COAST BRAKE SOLENOID.</b> Measure the resistance of harness connector between control valve body connector and transmission ground. <b>Connector &amp; terminal</b> <b>(T6) No. 1 — Transmission ground:</b>	Go to step 7.	Replace the control valve body. <Ref. to 5AT-53, Control Valve Body.>



# Diagnostic Procedure with Diagnostic Trouble Code (DTC)

AUTOMATIC TRANSMISSION (DIAGNOSTICS)

Step	Check	Yes	No
<b>7</b> <b>CHECK POOR CONTACT.</b> Check that there are no poor contact in TCM connector, transmission connector and control valve body connector.	Is there any loosing terminal, entering foreign matter, damaging connector body?	Repair the poor contact.	Go to step <b>8</b> .
<b>8</b> <b>CHECK AFTER REPAIR.</b> 1) Perform the clear memory mode. 2) Drive for a while, read the DTC, and check that there is no faulty.	Is DTC displayed?	Replace the TCM. <Ref. to 5AT-56, Transmission Control Module (TCM).>	Perform the P0882 diagnosis. <Ref. to 5AT(diag)-93, DTC P0882 TCM POWER INPUT SIGNAL LOW, Diagnostic Procedure with Diagnostic Trouble Code (DTC).>

# Diagnostic Procedure with Diagnostic Trouble Code (DTC)

AUTOMATIC TRANSMISSION (DIAGNOSTICS)

## AB:DTC P0801 REVERSE INHIBIT CONTROL CIRCUIT

### DTC DETECTING CONDITION:

Shift lock solenoid malfunction, open or short reverse inhibitor control circuit

### TROUBLE SYMPTOM:

- Gear is shifted from "N" range to "R" range during driving at 20 km/h (12MPH) or more.
- Gear can not be shifted from "N" range to "R" range though the vehicle is parked.

### WIRING DIAGRAM:

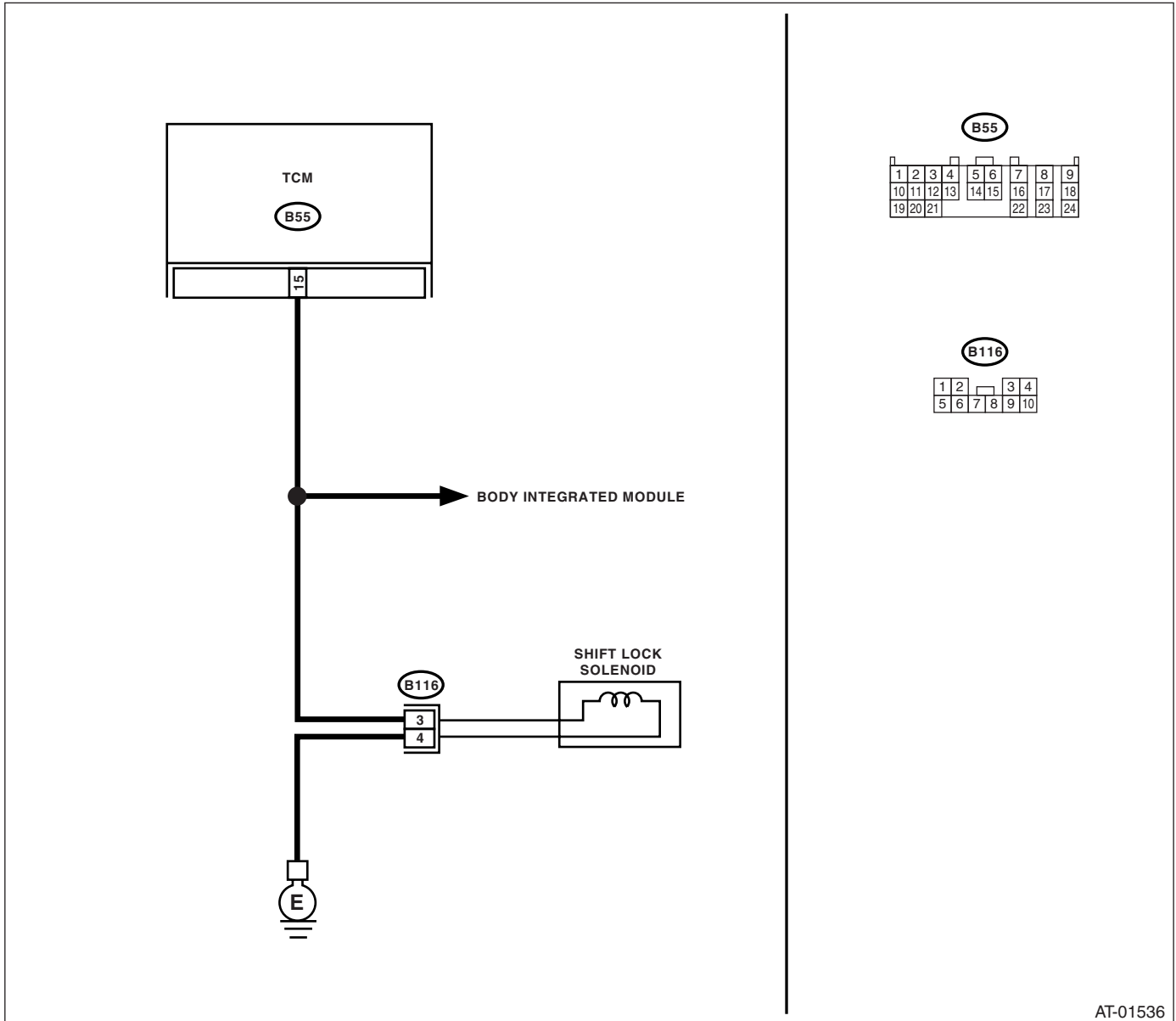

AT-01536

# Diagnostic Procedure with Diagnostic Trouble Code (DTC)

AUTOMATIC TRANSMISSION (DIAGNOSTICS)

Step	Check	Yes	No
<b>1 CHECK FUSE (No. 32).</b> 1) Turn the ignition switch to OFF. 2) Remove the fuse (No. 32).	Is the fuse (No. 32) blown out?	Replace the fuse (No. 32). If the replaced fuse has blown out easily, repair short circuit of harness between fuse (No. 32) and TCM.	Go to step 2.
<b>2 CHECK OUTPUT SIGNAL OF TCM.</b> 1) Turn the ignition switch to ON. 2) With the brake pedal depressed, shift the select lever to "D" range. 3) Measure the voltage between TCM and chassis ground. <b>Connector &amp; terminal</b> <b>(B55) No. 15 (+) — Chassis ground (-):</b>	Is the voltage more than 10.5 V?	Go to step 3.	Replace the TCM. <Ref. to 5AT-56, Transmission Control Module (TCM).>
<b>3 CHECK HARNESS CONNECTOR BETWEEN TCM AND SHIFT LOCK SOLENOID.</b> 1) Turn the ignition switch to OFF. 2) Disconnect the connector from TCM and shift lock solenoid. 3) Measure the resistance of harness between TCM and shift lock solenoid connector. <b>Connector &amp; terminal</b> <b>(B55) No. 15 — (B116) No. 3:</b>	Is the resistance less than 1 $\Omega$ ?	Go to step 4.	Repair the open circuit of harness between TCM and shift lock solenoid connector.
<b>4 CHECK HARNESS CONNECTOR BETWEEN TCM AND SHIFT LOCK SOLENOID.</b> Measure the resistance of harness between TCM and chassis ground. <b>Connector &amp; terminal</b> <b>(B55) No. 15 — Chassis ground:</b>	Is the resistance more than 1 M $\Omega$ ?	Go to step 5.	Repair the short circuit of harness between TCM and shift lock solenoid connector.
<b>5 CHECK HARNESS BETWEEN SHIFT LOCK SOLENOID AND CHASSIS GROUND TERMINAL.</b> Measure the resistance of harness between shift lock solenoid and chassis ground. <b>Connector &amp; terminal</b> <b>(B116) No. 4 — Chassis ground:</b>	Is the resistance less than 1 $\Omega$ ?	Go to step 6.	Repair the open circuit of harness between chassis ground and shift lock solenoid connector.
<b>6 CHECK SHIFT LOCK SOLENOID.</b> Measure the resistance of shift lock solenoid terminals. <b>Connector &amp; terminal</b> <b>(B116) No. 3 — No. 4:</b>	Is the resistance between 7 — 21 $\Omega$ ?	Go to step 7.	Replace the shift lock solenoid.

# Diagnostic Procedure with Diagnostic Trouble Code (DTC)

## AUTOMATIC TRANSMISSION (DIAGNOSTICS)

Step	Check	Yes	No
<p><b>7</b></p> <p><b>CHECK OUTPUT SIGNAL OF TCM.</b></p> <p>1) Lift-up the vehicle and support with rigid racks.</p> <p>NOTE: Raise all wheels off floor.</p> <p>2) Start the engine.</p> <p>3) Shift the select lever to "D" range and slowly increase vehicle speed to 20 km/h (12 MPH).</p> <p>NOTE: The speed difference between front and rear wheels may light the ABS warning light, but this indicates no malfunction. When AT control diagnosis is finished, perform the VDC memory clearance procedure of on-board diagnostics system. &lt;Ref. to VDC(diag)-18, CLEAR MEMORY MODE, OPERATION, Subaru Select Monitor.&gt;</p> <p>4) Measure the voltage between TCM and chassis ground.</p> <p><b>Connector &amp; terminal</b> <b>(B55) No. 15 (+) — Chassis ground (-):</b></p>	<p>Is the voltage less than 1 V?</p>	<p>Even if the SPORT indicator light up, the circuit has returned to normal condition at this time. A temporary poor contact of connector or harness may be the cause. Repair the harness or connector in reverse inhibitor control circuit.</p>	<p>Go to step <b>8</b>.</p>
<p><b>8</b></p> <p><b>CHECK POOR CONTACT.</b></p>	<p>Is there poor contact in the reverse inhibitor control circuit?</p>	<p>Repair the poor contact.</p>	<p>Replace the TCM. &lt;Ref. to 5AT-56, Transmission Control Module (TCM).&gt;</p>

# Diagnostic Procedure with Diagnostic Trouble Code (DTC)

AUTOMATIC TRANSMISSION (DIAGNOSTICS)

## AC:DTC P0817 STARTER DISABLE CIRCUIT

### DTC DETECTING CONDITION:

Open or short in P/N signal output circuit

### TROUBLE SYMPTOM:

- Engine can be started on other than "P" or "N" range
- Engine can not be started on "P" or "N" range.

### WIRING DIAGRAM:

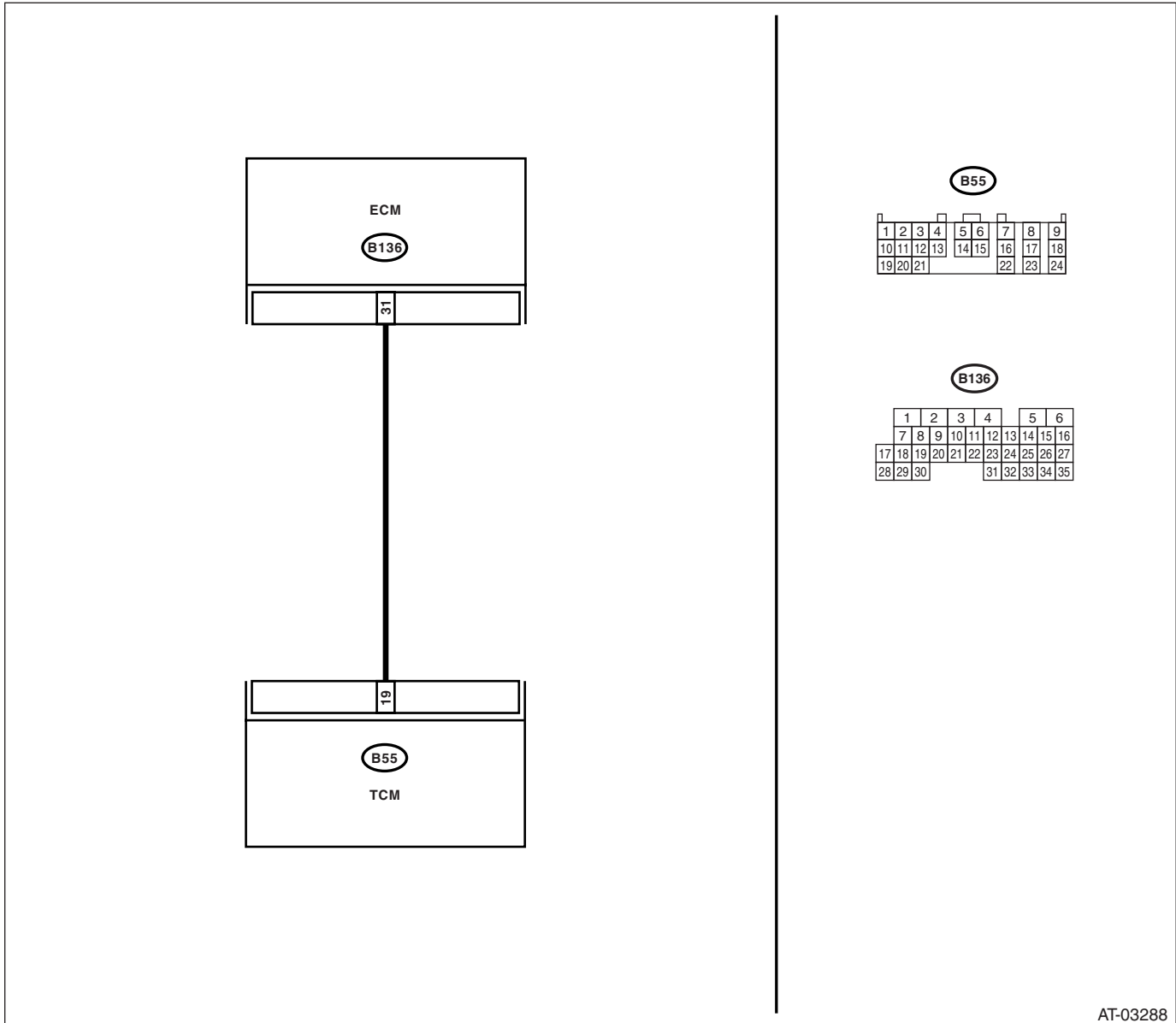

AT-03288

Step	Check	Yes	No
1	CHECK DTC OF TCM. Is DTC of Transmission Range Sensor Circuit (PRNDL Input) detected?	Perform the diagnosis according to DTC.	Go to step 2.
2	CHECK ECM. Is the communication between Subaru Select Monitor and ECM normal?	Go to step 3.	Perform the diagnosis according to DTC concerning ECM.

## Diagnostic Procedure with Diagnostic Trouble Code (DTC)

### AUTOMATIC TRANSMISSION (DIAGNOSTICS)

Step	Check	Yes	No
<b>3 CHECK FUSE (No. 32).</b> 1) Turn the ignition switch to OFF. 2) Remove the fuse.	Is the fuse (No. 32) blown out?	Replace the fuse (No. 32). If the replaced fuse (No. 32) has blown out easily, repair the short circuit of harness between fuse (No. 32) and TCM.	Go to step 4.
<b>4 CHECK HARNESS CONNECTOR BETWEEN TCM AND ECM.</b> 1) Turn the ignition switch to OFF. 2) Disconnect the connector from TCM and transmission. 3) Measure the resistance of harness between TCM connector and transmission connector. <i>Connector &amp; terminal (B55) No. 19 — (B136) No. 31:</i>	Is the resistance less than 1 $\Omega$ ?	Go to step 5.	Repair the open circuit of harness between TCM and transmission connector, or poor contact of connector.
<b>5 CHECK HARNESS CONNECTOR BETWEEN TCM AND ECM.</b> Measure the resistance of harness between TCM connector and chassis ground. <i>Connector &amp; terminal (B55) No. 19 — Chassis ground:</i>	Is the resistance more than 1 $M\Omega$ ?	Go to step 6.	Repair the short circuit of harness between transmission connector and chassis ground.
<b>6 CHECK TCM OUTPUT SIGNAL.</b> 1) Connect the TCM and ECM connector. 2) Turn the ignition switch to ON. (Engine OFF) 3) Shift the select lever to shift to the "P" range. 4) Measure the voltage between TCM connector and chassis ground. <i>Connector &amp; terminal (B55) No. 19 (+) — Chassis ground (-):</i>	Is the voltage less than 1 V?	Go to step 7.	Replace the TCM. <Ref. to 5AT-56, Transmission Control Module (TCM).>
<b>7 CHECK TCM OUTPUT SIGNAL.</b> 1) Shift the select lever to "D" range. 2) Measure the voltage between TCM connector and chassis ground. <i>Connector &amp; terminal (B55) No. 19 (+) — Chassis ground (-):</i>	Is the voltage more than 10 V?	Go to step 8.	Replace the TCM. <Ref. to 5AT-56, Transmission Control Module (TCM).>
<b>8 CHECK POOR CONTACT.</b>	Is there any open or poor contact of connector (loosing terminal, entering foreign matter, damaging connector body)?	Repair the poor contact.	Check the neutral switch of ECM.

# Diagnostic Procedure with Diagnostic Trouble Code (DTC)

AUTOMATIC TRANSMISSION (DIAGNOSTICS)

## AD:DTC P0882 TCM POWER INPUT SIGNAL LOW

### DTC DETECTING CONDITION:

Malfunction of PVIGN power supply relay or open, short circuit of PVIGN power supply circuit.

### TROUBLE SYMPTOM:

Gear is not changed.

### WIRING DIAGRAM:

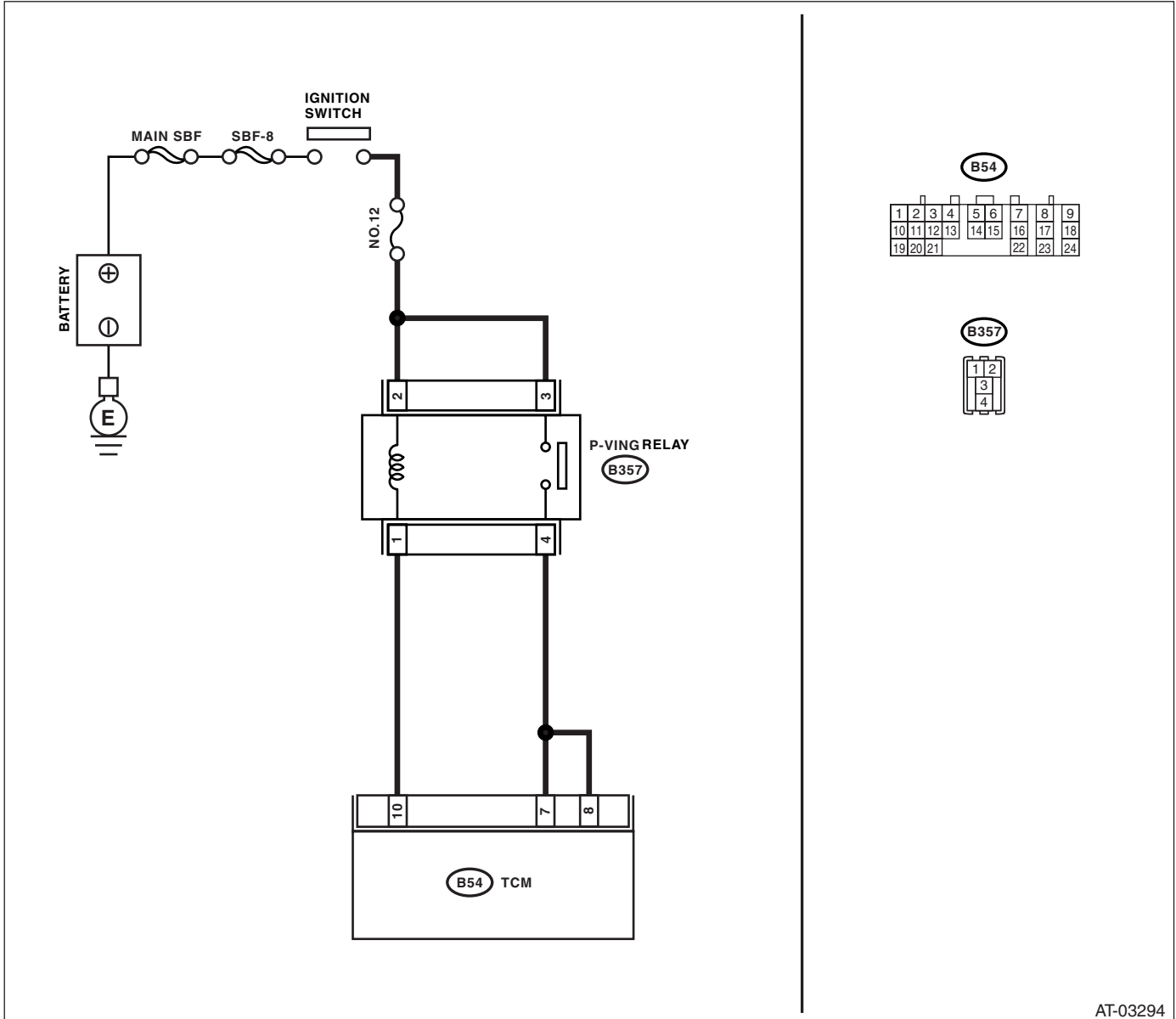

AT-03294

Step	Check	Yes	No
<b>1</b> <b>CHECK FUSE.</b> 1) Turn the ignition switch to OFF. 2) Remove the MAIN SBF, SBF 8 and fuse (No. 12), and then check those are not blown out.	Is the fuse blown out?	Replace the fuse. If the replaced fuse has blown out easily, repair the short circuit of harness of each fuse.	Go to step 2.

## Diagnostic Procedure with Diagnostic Trouble Code (DTC)

### AUTOMATIC TRANSMISSION (DIAGNOSTICS)

Step	Check	Yes	No
<b>2 CHECK INPUT VOLTAGE FOR PVIGN RELAY.</b> Measure the voltage between PVIGN relay and chassis ground. <i><b>Connector &amp; terminal</b></i> <i><b>(B357) No. 2 (+) — Chassis ground (-):</b></i> <i><b>(B357) No. 3 (+) — Chassis ground (-):</b></i>	Is the voltage 10 — 13 V?	Go to step 3.	Repair the open circuit of harness between fuse (No. 12) and PVIGN relay.
<b>3 CHECK HARNESS BETWEEN PVIGN RELAY OF TCM.</b> Measure the resistance between TCM connector and PVIGN relay connector. <i><b>Connector &amp; terminal</b></i> <i><b>(B54) No. 10 — (B357) No. 1:</b></i> <i><b>(B54) No. 7 — (B357) No. 4:</b></i> <i><b>(B54) No. 8 — (B357) No. 4:</b></i>	Is the resistance less than 1 $\Omega$ ?	Go to step 4.	Repair the open circuit of harness.
<b>4 CHECK PVIGN POWER SUPPLY CIRCUIT.</b> 1) Turn the ignition switch to ON. (Engine OFF) 2) Measure the voltage between TCM connector and chassis ground. <i><b>Connector &amp; terminal</b></i> <i><b>(B54) No. 7 (+) — Chassis ground (-):</b></i> <i><b>(B54) No. 8 (+) — Chassis ground (-):</b></i>	Is the voltage 10 — 13 V?	Temporary poor contact. Recheck the harness between TCM and relay. (Lightly move the harness and check that the open or short circuit is not occurred.)	Go to step 5.
<b>5 CHECK PVIGN RELAY OUTPUT OF TCM.</b> Measure the voltage between TCM connector and chassis ground. <i><b>Connector &amp; terminal</b></i> <i><b>(B55) No. 11 (+) — Chassis ground (-):</b></i>	Is the voltage less than 1.5 V?	Replace the PVIGN relay.	Replace the TCM. <Ref. to 5AT-56, Transmission Control Module (TCM).>



# Diagnostic Procedure with Diagnostic Trouble Code (DTC)

AUTOMATIC TRANSMISSION (DIAGNOSTICS)

## AE:DTC P0957 BACKUP LIGHT RELAY CIRCUIT LOW

### DTC DETECTING CONDITION:

Short circuit of back-up light relay output circuit

### TROUBLE SYMPTOM:

Back-up light does not illuminate in "R" range.

### WIRING DIAGRAM:

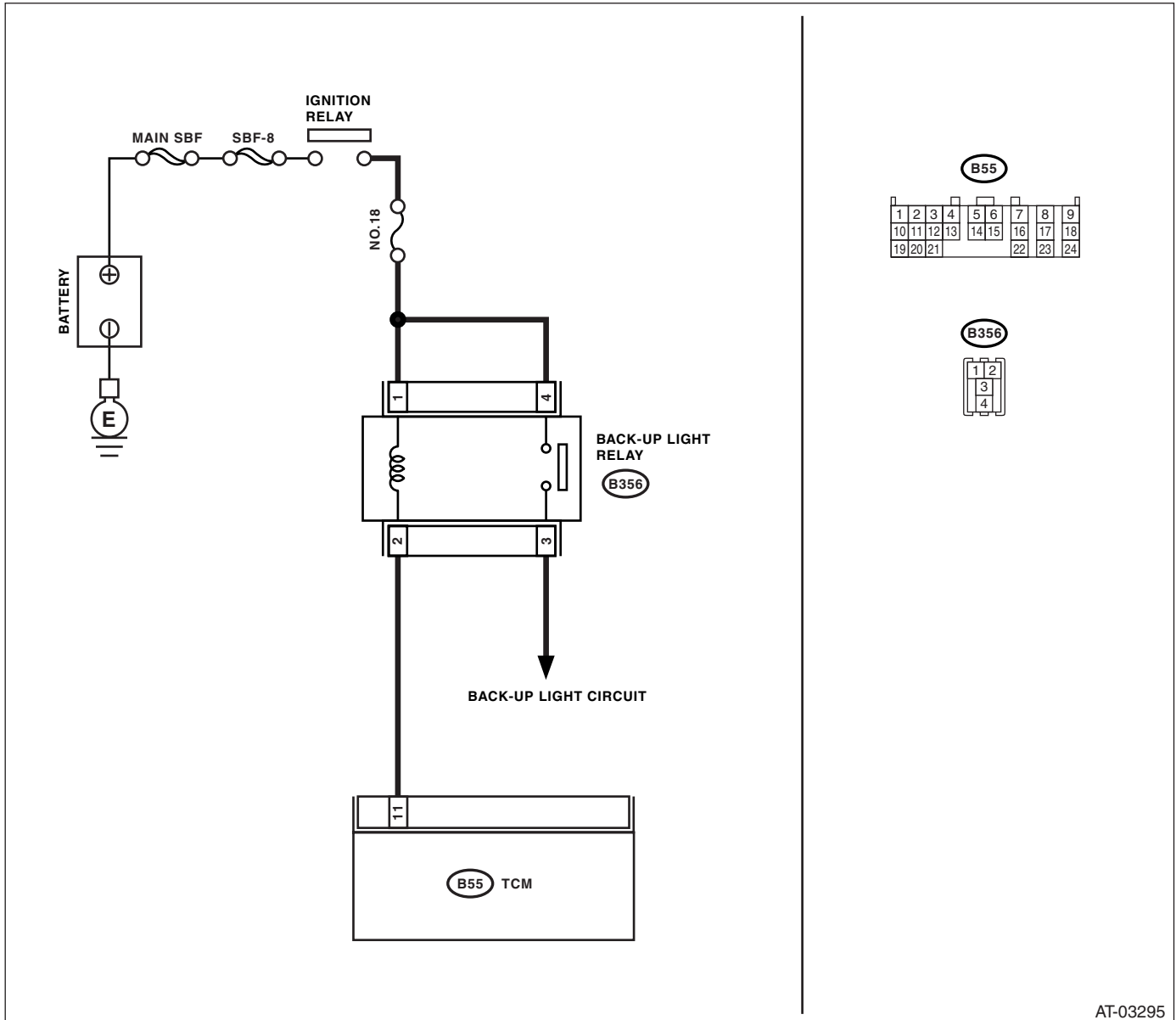

AT-03295

# Diagnostic Procedure with Diagnostic Trouble Code (DTC)

## AUTOMATIC TRANSMISSION (DIAGNOSTICS)

Step	Check	Yes	No	
1	<b>CHECK DTC OF TCM.</b>	Is DTC of Transmission Range Sensor Circuit (PRNDL Input) detected?	Perform the diagnosis according to DTC.	Go to step 2.
2	<b>CHECK HARNESS CONNECTOR BETWEEN TCM AND BACK-UP LIGHT RELAY.</b> 1) Turn the ignition switch to OFF. 2) Disconnect the connector from TCM and back-up light relay. 3) Measure the resistance of harness between TCM connector and back-up light relay connector. <b>Connector &amp; terminal</b> <b>(B55) No. 11 — (B356) No. 1:</b>	Is the resistance less than 1 $\Omega$ ?	Go to step 3.	Repair the open circuit of harness between TCM and transmission connector, or poor contact of connector.
3	<b>CHECK HARNESS CONNECTOR BETWEEN TCM AND TRANSMISSION.</b> Measure the resistance of harness between TCM connector and chassis ground. <b>Connector &amp; terminal</b> <b>(B55) No. 11 — Chassis ground:</b>	Is the resistance more than 1 M $\Omega$ ?	Go to step 4.	Repair the short circuit of harness between TCM and transmission connector.
4	<b>CHECK TCM OUTPUT SIGNAL.</b> 1) Turn the ignition switch to ON. (Engine OFF) 2) Move the select lever to "P" range. 3) Measure the voltage between TCM connector and chassis ground. <b>Connector &amp; terminal</b> <b>(B55) No. 11 — Chassis ground:</b>	Is the voltage more than 10 V?	Go to step 5.	Replace the TCM. <Ref. to 5AT-56, Transmission Control Module (TCM).>
5	<b>CHECK TCM OUTPUT SIGNAL.</b> 1) Set the select lever to "R" range. 2) Is the voltage less than 1 V? 3) Measure the voltage between TCM connector and chassis ground. <b>Connector &amp; terminal</b> <b>(B55) No. 11 — Chassis ground:</b>	Is the voltage 1.0 — 2.0 V?	Go to step 6.	Replace the TCM. <Ref. to 5AT-56, Transmission Control Module (TCM).>
6	<b>CHECK INPUT VOLTAGE FOR BACK-UP LIGHT RELAY.</b> Measure the voltage between back-up light relay and chassis ground.	Is the voltage 10 — 13 V?	Replace the back-up light relay.	Check open or short circuit of harness between fuse (No. 18) and back-up light relay.

# Diagnostic Procedure with Diagnostic Trouble Code (DTC)

AUTOMATIC TRANSMISSION (DIAGNOSTICS)

## AF:DTC P0958 BACKUP LIGHT RELAY CIRCUIT HIGH

### DTC DETECTING CONDITION:

Backup light relay malfunction, or open/short circuit in back-up light relay output circuit

### TROUBLE SYMPTOM:

- Back-up light does not illuminate in "R" range.
- Back-up light always illuminate except in "R" range.

### WIRING DIAGRAM:

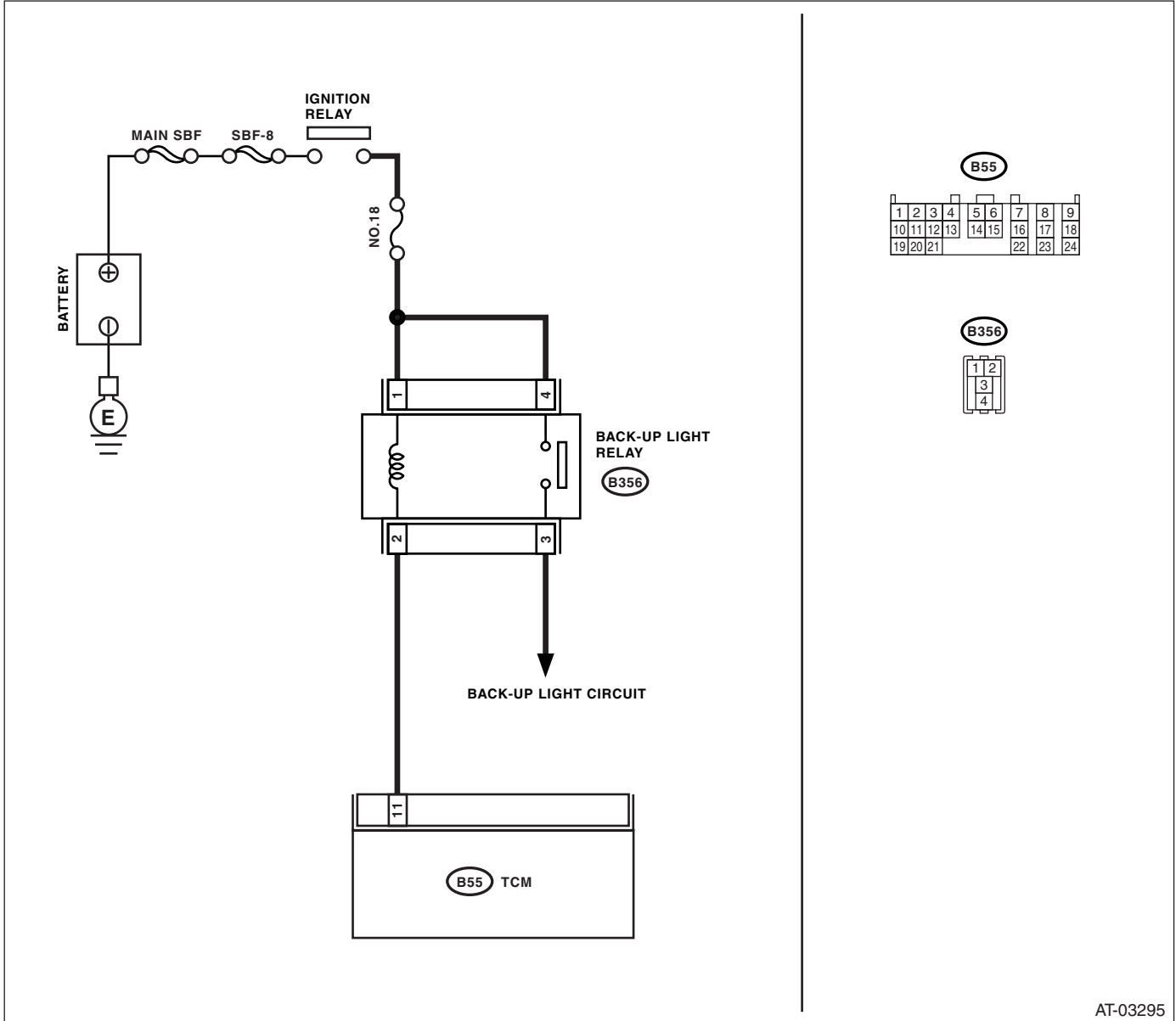

AT-03295

## Diagnostic Procedure with Diagnostic Trouble Code (DTC)

### AUTOMATIC TRANSMISSION (DIAGNOSTICS)

Step	Check	Yes	No	
1	<b>CHECK DTC OF TCM.</b>	Is DTC of Transmission Range Sensor Circuit (PRNDL Input) detected?	Perform the diagnosis according to DTC.	Go to step 2.
2	<b>CHECK HARNESS CONNECTOR BETWEEN TCM AND BACK-UP LIGHT RELAY.</b> 1) Turn the ignition switch to OFF. 2) Disconnect the connector from TCM and back-up light relay. 3) Measure the resistance of harness between TCM connector and back-up light relay connector. <b>Connector &amp; terminal</b> <b>(B55) No. 11 — (B356) No. 1:</b>	Is the resistance less than 1 $\Omega$ ?	Go to step 3.	Repair the open circuit of harness between TCM and transmission connector, or poor contact of connector.
3	<b>CHECK HARNESS CONNECTOR BETWEEN TCM AND TRANSMISSION.</b> Measure the resistance of harness between TCM connector and chassis ground. <b>Connector &amp; terminal</b> <b>(B55) No. 11 — Chassis ground:</b>	Is the resistance more than 1 M $\Omega$ ?	Go to step 4.	Repair the short circuit of harness between TCM and transmission connector.
4	<b>CHECK TCM OUTPUT SIGNAL.</b> 1) Turn the ignition switch to ON. (Engine OFF) 2) Move the select lever to "P" range. 3) Measure the voltage between TCM connector and chassis ground. <b>Connector &amp; terminal</b> <b>(B55) No. 11 — Chassis ground:</b>	Is the voltage more than 10 V?	Go to step 5.	Replace the TCM. <Ref. to 5AT-56, Transmission Control Module (TCM).>
5	<b>CHECK TCM OUTPUT SIGNAL.</b> 1) Set the select lever to "R" range. 2) Measure the voltage between TCM connector and chassis ground. <b>Connector &amp; terminal</b> <b>(B55) No. 11 — Chassis ground:</b>	Is the voltage 1.0 — 2.0 V or below?	Go to step 6.	Replace the TCM. <Ref. to 5AT-56, Transmission Control Module (TCM).>
6	<b>CHECK INPUT VOLTAGE FOR BACK-UP LIGHT RELAY.</b> Measure the voltage between back-up light relay and chassis ground.	Is the voltage 10 — 13 V?	Replace the back-up light relay.	Check open or short circuit of harness between fuse (No. 18) and back-up light relay.

# Diagnostic Procedure with Diagnostic Trouble Code (DTC)

AUTOMATIC TRANSMISSION (DIAGNOSTICS)

## AG:DTC P1601 TCM DATA COMMUNICATION FAILURE

### DTC DETECTING CONDITION:

Communication does not complete between control valve memory box.

### TROUBLE SYMPTOM:

Shifting quality malfunction

### WIRING DIAGRAM:

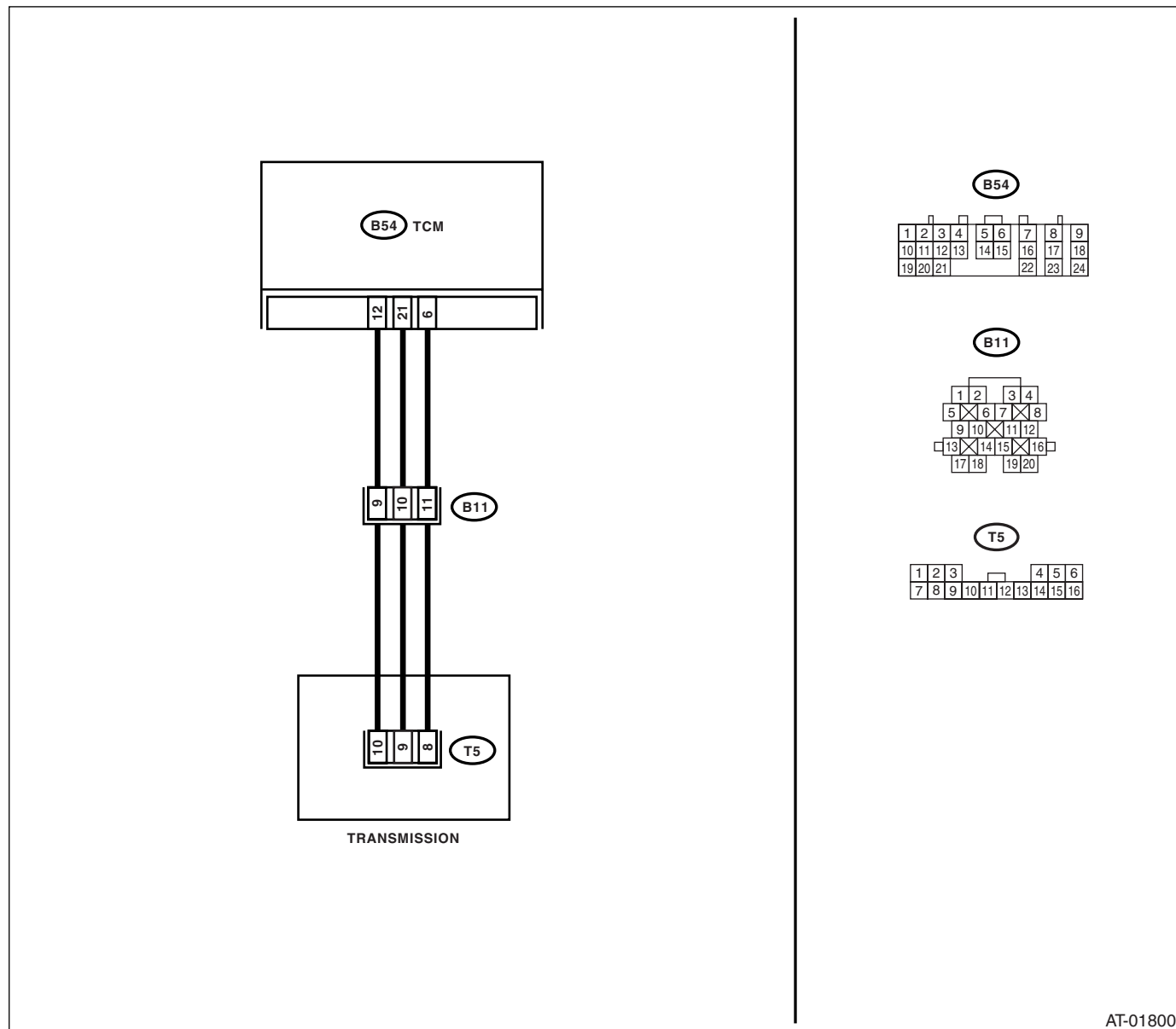

AT-01800

Step	Check	Yes	No
1	<b>CHECK IMPROPER CONNECTION OF TRANSMISSION CONNECTOR.</b> Check loose connection on TCM connector (B54).	Go to step 2.	Connect it securely.
2	<b>CHECK DTC OF TCM.</b>	Is DTC of oil pressure switch detected?	Perform the diagnosis according to DTC. Go to step 3.

# Diagnostic Procedure with Diagnostic Trouble Code (DTC)

## AUTOMATIC TRANSMISSION (DIAGNOSTICS)

Step	Check	Yes	No
<b>3 CHECK TCM OUTPUT SIGNAL.</b> 1) Turn the ignition switch to ON. (Engine OFF) 2) Measure the voltage between TCM connector and chassis ground. <i><b>Connector &amp; terminal</b></i> <i><b>(B54) No. 16 (+) — Chassis ground (-):</b></i>	Is the voltage 10 — 13 V?	Go to step 4.	Go to step 5.
<b>4 CHECK HARNESS CONNECTOR BETWEEN TCM AND TRANSMISSION.</b> 1) Turn the ignition switch to OFF. 2) Disconnect the connectors from TCM and transmission. 3) Measure the resistance of harness between TCM connector and transmission connector. <i><b>Connector &amp; terminal</b></i> <i><b>(B54) No. 12 — (B11) No. 9:</b></i> <i><b>(B54) No. 21 — (B11) No. 10:</b></i> <i><b>(B54) No. 6 — (B11) No. 11:</b></i>	Is the resistance less than 1 $\Omega$ ?	Go to step 5.	Repair the open circuit of harness between TCM and transmission connector, or poor contact of connector.
<b>5 CHECK HARNESS CONNECTOR BETWEEN TCM AND TRANSMISSION.</b> Measure the resistance of harness between TCM connector and chassis ground. <i><b>Connector &amp; terminal</b></i> <i><b>(B54) No. 12 — Chassis ground:</b></i> <i><b>(B54) No. 21 — Chassis ground:</b></i> <i><b>(B54) No. 6 — Chassis ground:</b></i>	Is the resistance more than 1 M $\Omega$ ?	Go to step 6.	Repair the short circuit of harness between TCM and transmission connector.
<b>6 CHECK HARNESS CONNECTOR BETWEEN TRANSMISSION CONNECTOR AND CONTROL VALVE BODY CONNECTOR.</b> Measure the resistance between transmission connector and control valve body connector. <i><b>Connector &amp; terminal</b></i> <i><b>(B11) No. 9 — (T5) No. 10:</b></i> <i><b>(B11) No. 10 — (T5) No. 9:</b></i> <i><b>(B11) No. 11 — (T5) No. 8:</b></i>	Is the resistance less than 1 $\Omega$ ?	Go to step 7.	Repair the open circuit of harness between transmission connector and control valve body connector.
<b>7 CHECK HARNESS CONNECTOR BETWEEN TRANSMISSION CONNECTOR AND CONTROL VALVE BODY CONNECTOR.</b> Measure the resistance between transmission connector and chassis ground. <i><b>Connector &amp; terminal</b></i> <i><b>(B11) No. 9 — Chassis ground:</b></i> <i><b>(B11) No. 10 — Chassis ground:</b></i> <i><b>(B11) No. 11 — Chassis ground:</b></i>	Is the resistance more than 1 M $\Omega$ ?	Go to step 8.	Repair the short circuit of harness between transmission connector and control valve body connector.
<b>8 CHECK POOR CONTACT.</b> NOTE: Data communication malfunction is detected when the malfunction occurred on inspection area above while transmission assembly is replacing or "Clear Memory 2" is performing. When the repair is performed with following diagnosis above, perform the "Clear Memory 2", and then recheck that the DTC of TCM data communication malfunction is not detected.	Is there any open or poor contact of connector (loosing terminal, entering foreign matter, damaging connector body)?	Repair the poor contact.	Replace the transmission assembly. <Ref. to 5AT-34, Automatic Transmission Assembly.>

# Diagnostic Procedure with Diagnostic Trouble Code (DTC)

AUTOMATIC TRANSMISSION (DIAGNOSTICS)

## AH:DTC P1706 AT VEHICLE SPEED SENSOR CIRCUIT MALFUNCTION (REAR WHEEL)

### DTC DETECTING CONDITION:

Input signal circuit of TCM is open or shorted.

### TROUBLE SYMPTOM:

- Shifting quality malfunction
- Tight corner braking phenomenon is occurred.

### WIRING DIAGRAM:

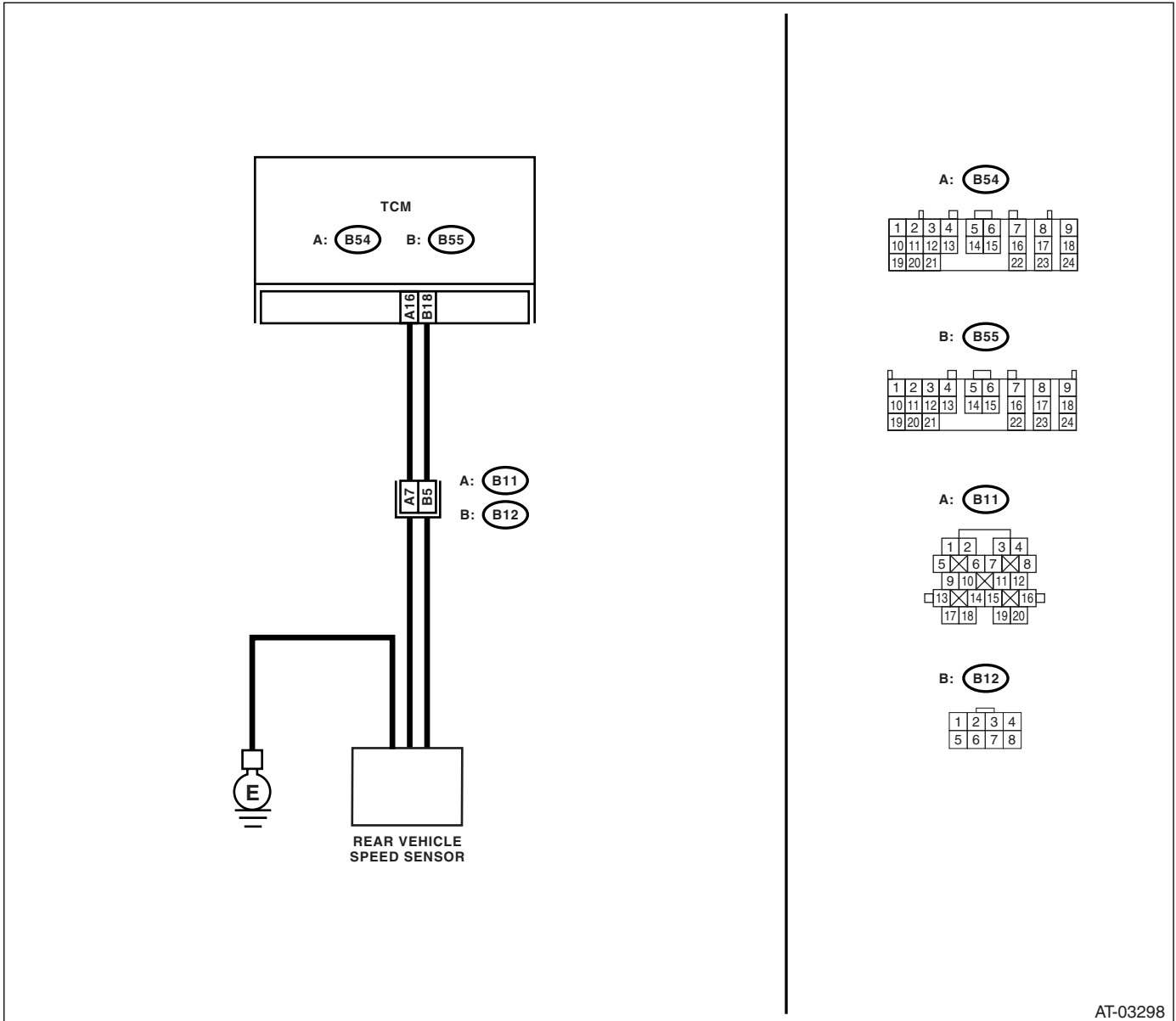

AT-03298

# Diagnostic Procedure with Diagnostic Trouble Code (DTC)

## AUTOMATIC TRANSMISSION (DIAGNOSTICS)

Step	Check	Yes	No
<b>1 CHECK HARNESS CONNECTOR BETWEEN TCM AND TRANSMISSION.</b> 1) Turn the ignition switch to OFF. 2) Disconnect the connectors from TCM and transmission. 3) Measure the resistance of harness between TCM connector and transmission connector.  <i>Connector &amp; terminal</i> <i>(B54) No. 16 — (B11) No. 7:</i> <i>(B55) No. 18 — (B12) No. 5:</i>	Is the resistance less than 1 $\Omega$ ?	Go to step 2.	Repair the open circuit of harness between TCM and transmission connector.
<b>2 CHECK HARNESS CONNECTOR BETWEEN TCM AND TRANSMISSION.</b> Measure the resistance of harness between TCM connector and chassis ground.  <i>Connector &amp; terminal</i> <i>(B54) No. 16 — Chassis ground:</i> <i>(B55) No. 18 — Chassis ground:</i>	Is the resistance more than 1 $M\Omega$ ?	Go to step 3.	Repair the short circuit of harness between TCM and chassis ground.
<b>3 CHECK TCM POWER SUPPLY OUTPUT.</b> 1) Connect the connector to TCM. (Transmission connector is disconnected) 2) Turn the ignition switch to ON. (Engine OFF) 3) Measure the voltage between TCM connector and chassis ground.  <i>Connector &amp; terminal</i> <i>(B54) No. 16 (+) — Chassis ground (-):</i>	Is the voltage 10 — 13 V?	Go to step 4.	Go to step 5.
<b>4 CHECK TURBINE SPEED SENSOR INPUT CIRCUIT OF TCM.</b> Measure the voltage between TCM connector terminals.  <i>Connector &amp; terminal</i> <i>(B55) No. 18 (+) — (B54) No. 19 (-):</i>	Is the voltage 4 — 6 V?	Go to step 6.	Go to step 5.
<b>5 CHECK TCM I/O SIGNAL.</b> Check TCM I/O signal of power supply, ground and PVIGN power supply relay. <Ref. to 5AT(diag)-11, ELECTRICAL SPECIFICATION, Transmission Control Module (TCM) I/O Signal.>	Is TCM I/O signal OK?	Replace the TCM. <Ref. to 5AT-56, Transmission Control Module (TCM).>	Repair the open or short circuit for power supply and ground. Perform the diagnosis according to DTC for PVIGN power supply relay.
<b>6 CHECK HARNESS ASSEMBLY (TURBINE SPEED SENSOR GROUND).</b> Check the installing condition of ground connecting harness (used for both of turbine speed sensor 1, rear vehicle speed sensor).	Is the ground connecting harness installed to transmission body correctly, or the harness and connector terminals not damaged?	Go to step 7.	When the poor installation of ground connecting harness, install it securely. Replace the transmission assembly when the harness is damaged. <Ref. to 5AT-34, Automatic Transmission Assembly.>



# Diagnostic Procedure with Diagnostic Trouble Code (DTC)

AUTOMATIC TRANSMISSION (DIAGNOSTICS)

Step	Check	Yes	No
<p>7</p> <p><b>CHECK INPUT SIGNAL FOR TCM USING SUBARU SELECT MONITOR.</b></p> <p>1) Connect all the connectors.</p> <p>2) Lift-up the vehicle and support with rigid racks.</p> <p>NOTE: Raise all wheels off floor.</p> <p>3) Start the engine, and drive the vehicle.</p> <p>4) Read the current data of front wheel speed using Subaru Select Monitor. &lt;Ref. to 5AT(diag)-15, OPERATION, Subaru Select Monitor.&gt;</p> <p>NOTE: The speed difference between front and rear wheels may light the ABS warning light, but this indicates no malfunction. When AT control diagnosis is finished, perform the VDC memory clearance procedure of on-board diagnostics system. &lt;Ref. to VDC(diag)-18, CLEAR MEMORY MODE, OPERATION, Subaru Select Monitor.&gt;</p>	<p>Does the value of the front wheel speed depending on the acceleration and deceleration of the vehicle?</p>	<p>Even if the SPORT indicator light blinks, the system is in normal condition. A temporary poor contact of connector or harness may be the cause. Repair poor contact of harness in ATF temperature sensor and transmission connector.</p>	<p>Replace the transmission harness.</p>

# Diagnostic Procedure with Diagnostic Trouble Code (DTC)

AUTOMATIC TRANSMISSION (DIAGNOSTICS)

## AI: DTC P1707 AT AWD SOLENOID VALVE CIRCUIT MALFUNCTION

### DTC DETECTING CONDITION:

Output signal circuit of transfer solenoid is open or shorted.

### TROUBLE SYMPTOM:

- Tight corner braking phenomenon is occurred.
- Drivability getting worse.

### WIRING DIAGRAM:

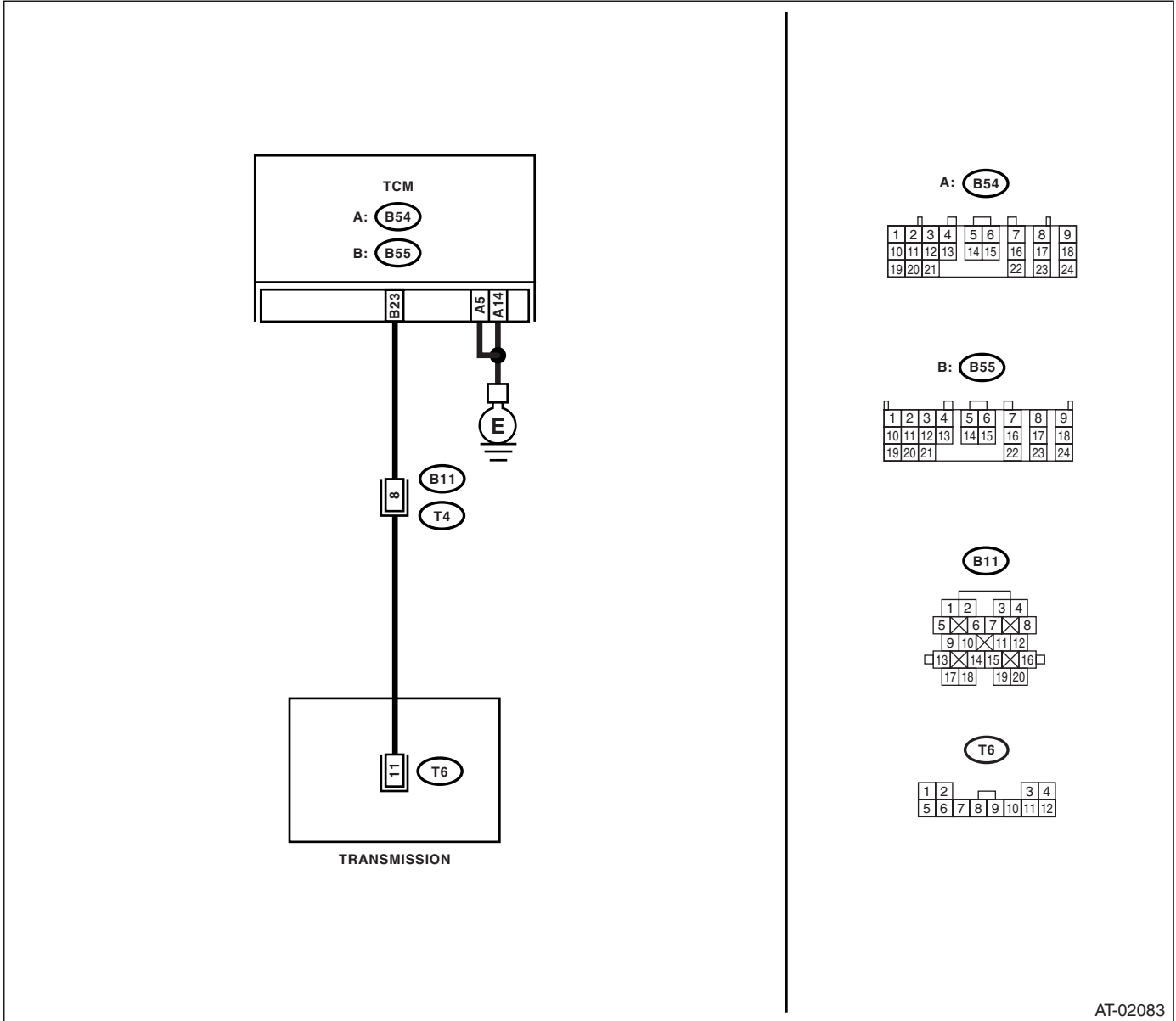

# Diagnostic Procedure with Diagnostic Trouble Code (DTC)

AUTOMATIC TRANSMISSION (DIAGNOSTICS)

Step	Check	Yes	No
<p><b>1</b></p> <p><b>CHECK HARNESS CONNECTOR BETWEEN TCM AND TRANSMISSION.</b></p> <p>1) Turn the ignition switch to OFF. 2) Disconnect the connectors from TCM and transmission. 3) Measure the resistance of harness between TCM and transmission connector.</p> <p><b>Connector &amp; terminal</b> <b>(B55) No. 23 — (B11) No. 8:</b> <b>(B54) No. 5 — Chassis ground:</b> <b>(B54) No. 14 — Chassis ground:</b></p>	<p>Is the resistance less than 1 <math>\Omega</math>?</p>	<p>Go to step 2.</p>	<p>Repair the open circuit of harness between TCM connector and transmission connector.</p>
<p><b>2</b></p> <p><b>CHECK HARNESS CONNECTOR BETWEEN TCM AND CHASSIS GROUND.</b></p> <p>Measure the resistance of harness between TCM connector and chassis ground.</p> <p><b>Connector &amp; terminal</b> <b>(B55) No. 23 — Chassis ground:</b></p>	<p>Is the resistance more than 1 <math>M\Omega</math>?</p>	<p>Go to step 3.</p>	<p>Repair the short circuit of harness between TCM connector and transmission connector.</p>
<p><b>3</b></p> <p><b>CHECK HARNESS CONNECTOR BETWEEN TRANSMISSION AND CONTROL VALVE BODY.</b></p> <p>1) Turn the ignition switch to OFF. 2) Disconnect the connector from transmission. 3) Remove the transmission connector from bracket. 4) Lift-up the vehicle and place it on rigid racks.</p> <p>NOTE: Raise all wheels off floor. 5) Drain the ATF.</p> <p><b>CAUTION:</b> <b>Do not drain ATF until it cools down.</b></p> <p>6) Remove the oil pan, and disconnect the control valve body connector. 7) Measure the resistance between transmission connector and control valve body connector.</p> <p><b>Connector &amp; terminal</b> <b>(T4) No. 8 — (T6) No. 11:</b></p>	<p>Is the resistance less than 1 <math>\Omega</math>?</p>	<p>Go to step 4.</p>	<p>Repair the open circuit of harness between transmission connector and control valve body connector.</p>
<p><b>4</b></p> <p><b>CHECK HARNESS CONNECTOR BETWEEN TRANSMISSION AND CONTROL VALVE BODY.</b></p> <p>Measure the resistance between transmission ground and control valve body connector.</p> <p><b>Connector &amp; terminal</b> <b>(T6) No. 11 — Transmission ground:</b></p>	<p>Is the resistance more than 1 <math>M\Omega</math>?</p>	<p>Go to step 5.</p>	<p>Repair the short circuit of harness between control valve body connector and transmission ground.</p>
<p><b>5</b></p> <p><b>CHECK AWD SOLENOID.</b></p> <p>Measure the resistance between transmission ground and control valve body connector.</p> <p><b>Connector &amp; terminal</b> <b>(T6) No. 11 — Transmission ground:</b></p>	<p>Is the resistance between 3 — 9 <math>\Omega</math>?</p>	<p>Go to step 6.</p>	<p>Replace the control valve body. &lt;Ref. to 5AT-53, Control Valve Body.&gt;</p>

# Diagnostic Procedure with Diagnostic Trouble Code (DTC)

## AUTOMATIC TRANSMISSION (DIAGNOSTICS)

Step	Check	Yes	No
<b>6</b> <b>CHECK POOR CONTACT.</b> Check that there are no poor contact in TCM connector, transmission connector and control valve body connector.	Is there any loosing terminal, entering foreign matter, damaging connector body?	Repair the poor contact.	Go to step 7.
<b>7</b> <b>CHECK AFTER REPAIR.</b> 1) Perform the clear memory mode. 2) Drive for a while, read the DTC, and check that there is no faulty.	Is DTC displayed?	Replace the TCM. <Ref. to 5AT-56, Transmission Control Module (TCM).>	Temporary poor contact or open circuit occurs. Recheck that the harness connector has no faulty.

# Diagnostic Procedure with Diagnostic Trouble Code (DTC)

AUTOMATIC TRANSMISSION (DIAGNOSTICS)

## AJ:DTC P1710 TORQUE CONVERTER TURBINE 2 SPEED SIGNAL CIRCUIT 2 MALFUNCTION

### DTC DETECTING CONDITION:

Input signal circuit of TCM is open or shorted.

### TROUBLE SYMPTOM:

- Excessive shift shock
- Does not shift to 5th

### WIRING DIAGRAM:

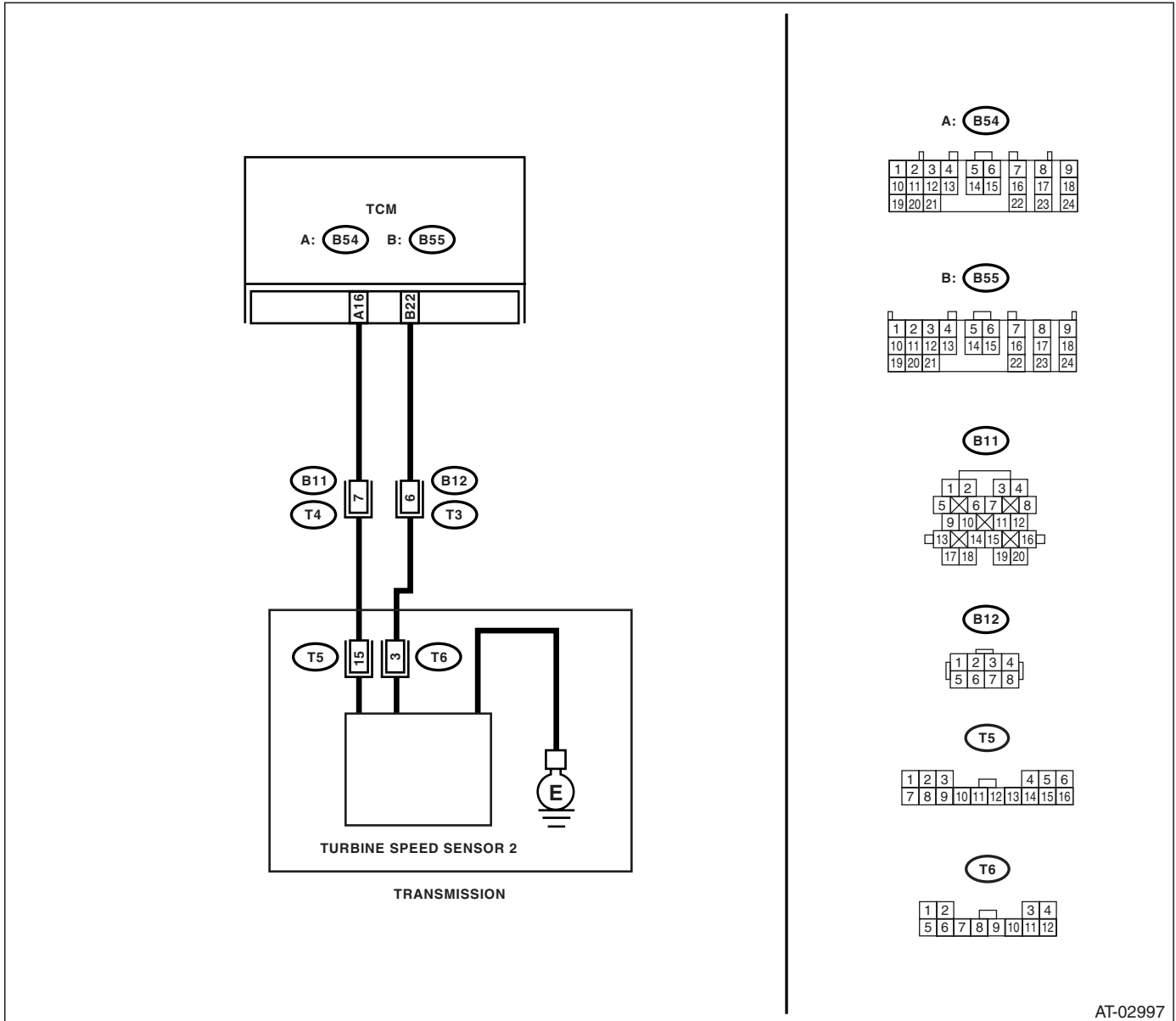

AT-02997

# Diagnostic Procedure with Diagnostic Trouble Code (DTC)

## AUTOMATIC TRANSMISSION (DIAGNOSTICS)

Step	Check	Yes	No
<b>1 CHECK HARNESS CONNECTOR BETWEEN TCM AND TRANSMISSION.</b> 1) Turn the ignition switch to OFF. 2) Disconnect the connectors from TCM and transmission. 3) Measure the resistance of harness between TCM connector and transmission connector.  <i>Connector &amp; terminal</i> <i>(B55) No. 22 — (B12) No. 6:</i> <i>(B54) No. 16 — (B11) No. 7:</i>	Is the resistance less than 1 $\Omega$ ?	Go to step 2.	Repair the open circuit of harness between TCM and transmission connector.
<b>2 CHECK HARNESS CONNECTOR BETWEEN TCM AND TRANSMISSION.</b> Measure the resistance of harness between TCM connector and chassis ground.  <i>Connector &amp; terminal</i> <i>(B55) No. 22 — Chassis ground:</i> <i>(B54) No. 16 — Chassis ground:</i>	Is the resistance more than 1 $M\Omega$ ?	Go to step 3.	Repair the short circuit of harness between TCM and transmission connector.
<b>3 CHECK TCM POWER SUPPLY OUTPUT.</b> 1) Connect the connector to TCM. (Transmission connector is disconnected) 2) Turn the ignition switch to ON. (Engine OFF) 3) Measure the voltage between TCM connector and chassis ground.  <i>Connector &amp; terminal</i> <i>(B54) No. 16 (+) — (B54) No. 19 (-):</i>	Is the voltage 10 — 13 V?	Go to step 4.	Go to step 5.
<b>4 CHECK TURBINE SPEED SENSOR INPUT CIRCUIT OF TCM.</b> Measure the voltage between TCM connector terminals.  <i>Connector &amp; terminal</i> <i>(B55) No. 22 (+) — (B54) No. 19 (-):</i>	Is the voltage 4 — 6 V?	Go to step 6.	Go to step 5.
<b>5 CHECK TCM I/O SIGNAL.</b> Check TCM I/O signal of power supply, ground and PVIGN power supply relay. <Ref. to 5AT(diag)-11, ELECTRICAL SPECIFICATION, Transmission Control Module (TCM) I/O Signal.>	Is I/O signal OK?	Replace the TCM. <Ref. to 5AT-56, Transmission Control Module (TCM).>	Repair the open or short circuit for power supply and ground. Perform the diagnosis according to DTC for PVIGN power supply relay.

# Diagnostic Procedure with Diagnostic Trouble Code (DTC)

AUTOMATIC TRANSMISSION (DIAGNOSTICS)

	Step	Check	Yes	No
6	<p><b>CHECK INPUT SIGNAL FOR TCM USING SUBARU SELECT MONITOR.</b></p> <p>1) Connect all the connectors.</p> <p>2) Lift-up the vehicle and support with rigid racks.</p> <p>NOTE: Raise all wheels off floor.</p> <p>3) Start the engine, and set the vehicle in 1st speed driving condition of manual mode.</p> <p>4) Read the current data of torque converter turbine speed 2 using Subaru Select Monitor. &lt;Ref. to 5AT(diag)-15, OPERATION, Subaru Select Monitor.&gt;</p> <p>NOTE: The speed difference between front and rear wheels may light the ABS warning light, but this indicates no malfunction. When AT control diagnosis is finished, perform the VDC memory clearance procedure of on-board diagnostics system. &lt;Ref. to VDC(diag)-18, CLEAR MEMORY MODE, OPERATION, Subaru Select Monitor.&gt;</p>	<p>Does the value of the turbine speed sensor 2 change depending on the acceleration, deceleration and shifting gear of the vehicle?</p>	<p>Even if the SPORT indicator light blinks, the system is in normal condition. A temporary poor contact of connector or harness may be the cause. Repair the poor contact of harness of turbine speed sensor 2 and transmission connector.</p>	<p>Go to step 7.</p>
7	<p><b>CHECK HARNESS CONNECTOR BETWEEN TRANSMISSION AND CONTROL VALVE BODY.</b></p> <p>1) Turn the ignition switch to OFF.</p> <p>2) Disconnect the connector from transmission.</p> <p>3) Remove the transmission connector from bracket.</p> <p>4) Lift-up the vehicle and place it on rigid racks.</p> <p>NOTE: Raise all wheels off floor.</p> <p>5) Drain the ATF.</p> <p><b>CAUTION:</b> <b>Do not drain ATF until it cools down.</b></p> <p>6) Remove the oil pan, and disconnect the connector from control valve body connector.</p> <p>7) Measure the resistance between transmission connector and control valve body connector.</p> <p><b>Connector &amp; terminal</b> <b>(T3) No. 6 — (T6) No. 3:</b> <b>(T4) No. 7 — (T5) No. 15:</b></p>	<p>Is the resistance less than 1 <math>\Omega</math>?</p>	<p>Go to step 8.</p>	<p>Repair the open circuit of harness between transmission connector and control valve body connector.</p>
8	<p><b>CHECK HARNESS CONNECTOR BETWEEN TRANSMISSION AND CONTROL VALVE BODY.</b></p> <p>Measure the resistance between transmission ground and control valve body connector.</p> <p><b>Connector &amp; terminal</b> <b>(T6) No. 3 — Transmission ground:</b> <b>(T5) No. 15 — Transmission ground:</b></p>	<p>Is the resistance more than 1 <math>M\Omega</math>?</p>	<p>Replace the control valve body. &lt;Ref. to 5AT-53, Control Valve Body.&gt;</p>	<p>Repair the short circuit of harness between transmission connector and transmission ground.</p>

# Diagnostic Procedure with Diagnostic Trouble Code (DTC)

AUTOMATIC TRANSMISSION (DIAGNOSTICS)

## AK:DTC P1716 ATF TEMP. SENSOR 2 CIRCUIT LOW

### DTC DETECTING CONDITION:

Input signal circuit to ATF temperature sensor 2 is open or shorted.

### TROUBLE SYMPTOM:

Excessive shift shock

### WIRING DIAGRAM:

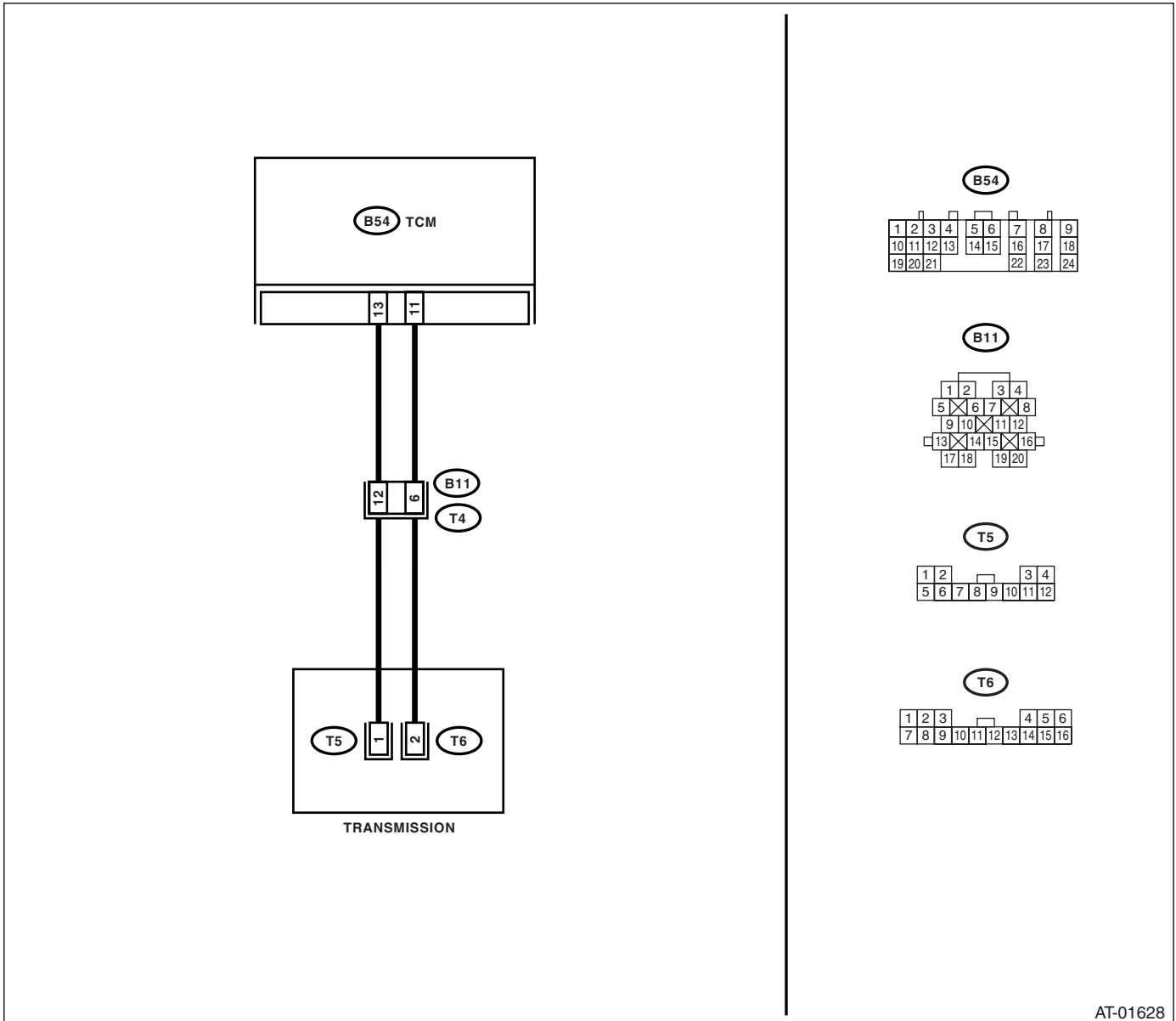

AT-01628



# Diagnostic Procedure with Diagnostic Trouble Code (DTC)

AUTOMATIC TRANSMISSION (DIAGNOSTICS)

Step	Check	Yes	No
<b>1 CHECK HARNESS CONNECTOR BETWEEN TCM AND TRANSMISSION.</b> 1) Turn the ignition switch to OFF. 2) Disconnect the connectors from TCM and transmission. 3) Measure the resistance of harness between TCM and transmission connector. <b>Connector &amp; terminal</b> <b>(B54) No. 13 — (B11) No. 12:</b> <b>(B54) No. 11 — (B11) No. 6:</b>	Is the resistance less than 1 $\Omega$ ?	Go to step 2.	Repair the open circuit of harness between TCM and transmission connector.
<b>2 CHECK ATF TEMPERATURE SENSOR.</b> 1) Turn the ignition switch to OFF. 2) Connect the connectors to transmission and TCM. 3) Turn the ignition switch to ON and start engine. 4) Warm-up the transmission until the ATF temperature reaches to 80°C (176°F). NOTE: If the ambient temperature falls below 0°C (32°F), drive the vehicle until the ATF reaches its operating temperature. 5) Disconnect the connector from transmission. 6) Measure the resistance between transmission connector terminals. <b>Connector &amp; terminal</b> <b>(T4) No. 6 — (T4) No.12:</b>	Is the resistance between 300 — 700 $\Omega$ ?	Go to step 3.	Go to step 5.
<b>3 CHECK ATF TEMPERATURE SENSOR.</b> Measure the resistance between transmission connector terminals. <b>Connector &amp; terminal</b> <b>(T4) No. 6 — (T4) No.12:</b>	Does the resistance value increase while the ATF temperature decreases?	Go to step 4.	Go to step 5.
<b>4 CHECK INPUT SIGNAL FOR TCM USING SUBARU SELECT MONITOR.</b> 1) Connect the connector. 2) Turn the ignition switch to ON. (Engine OFF) 3) Read the ATF temperature using Subaru Select Monitor.	Does the ATF temperature gradually decrease?	Even if the SPORT indicator light blinks, the system is in normal condition. A temporary poor contact of connector or harness may be the cause. Repair the poor contacts of harnesses of ATF temperature sensor and transmission connector.	Go to step 6.

## Diagnostic Procedure with Diagnostic Trouble Code (DTC)

### AUTOMATIC TRANSMISSION (DIAGNOSTICS)

Step	Check	Yes	No
<p><b>5</b></p> <p><b>CHECK HARNESS CONNECTOR BETWEEN TRANSMISSION AND CONTROL VALVE BODY.</b></p> <p>1) Turn the ignition switch to OFF.                      2) Disconnect the connector from transmission.                      3) Remove the transmission connector from bracket.                      4) Lift-up the vehicle and place it on rigid racks.</p> <p>NOTE:                      Raise all wheels off floor.                      5) Drain the ATF.</p> <p><b>CAUTION:</b>  <b>Do not drain ATF until it cools down.</b></p> <p>6) Remove the oil pan, and disconnect the connector from control valve body connector.                      7) Measure the resistance between transmission connector and control valve body connector.</p> <p><i>Connector &amp; terminal</i>  <i>(T4) No. 12 — (T5) No. 1:</i>  <i>(T4) No. 6 — (T6) No. 2:</i></p>	<p>Is the resistance less than 1 <math>\Omega</math>?</p>	<p>Replace the control valve body.                      &lt;Ref. to 5AT-53, Control Valve Body.&gt;</p>	<p>Repair the open circuit of harness between transmission connector and control valve body connector.</p>
<p><b>6</b></p> <p><b>CHECK POOR CONTACT.</b>                      Check poor contact of ATF temperature sensor 1 circuit.</p>	<p>Is there poor contact?</p>	<p>Repair the poor contact.</p>	<p>Replace the TCM.                      &lt;Ref. to 5AT-56, Transmission Control Module (TCM).&gt;</p>

# Diagnostic Procedure with Diagnostic Trouble Code (DTC)

AUTOMATIC TRANSMISSION (DIAGNOSTICS)

## AL:DTC P1717 ATF TEMP. SENSOR 2 CIRCUIT HIGH

### DTC DETECTING CONDITION:

Input signal circuit to ATF temperature sensor 2 is open or shorted.

### TROUBLE SYMPTOM:

Excessive shift shock

### WIRING DIAGRAM:

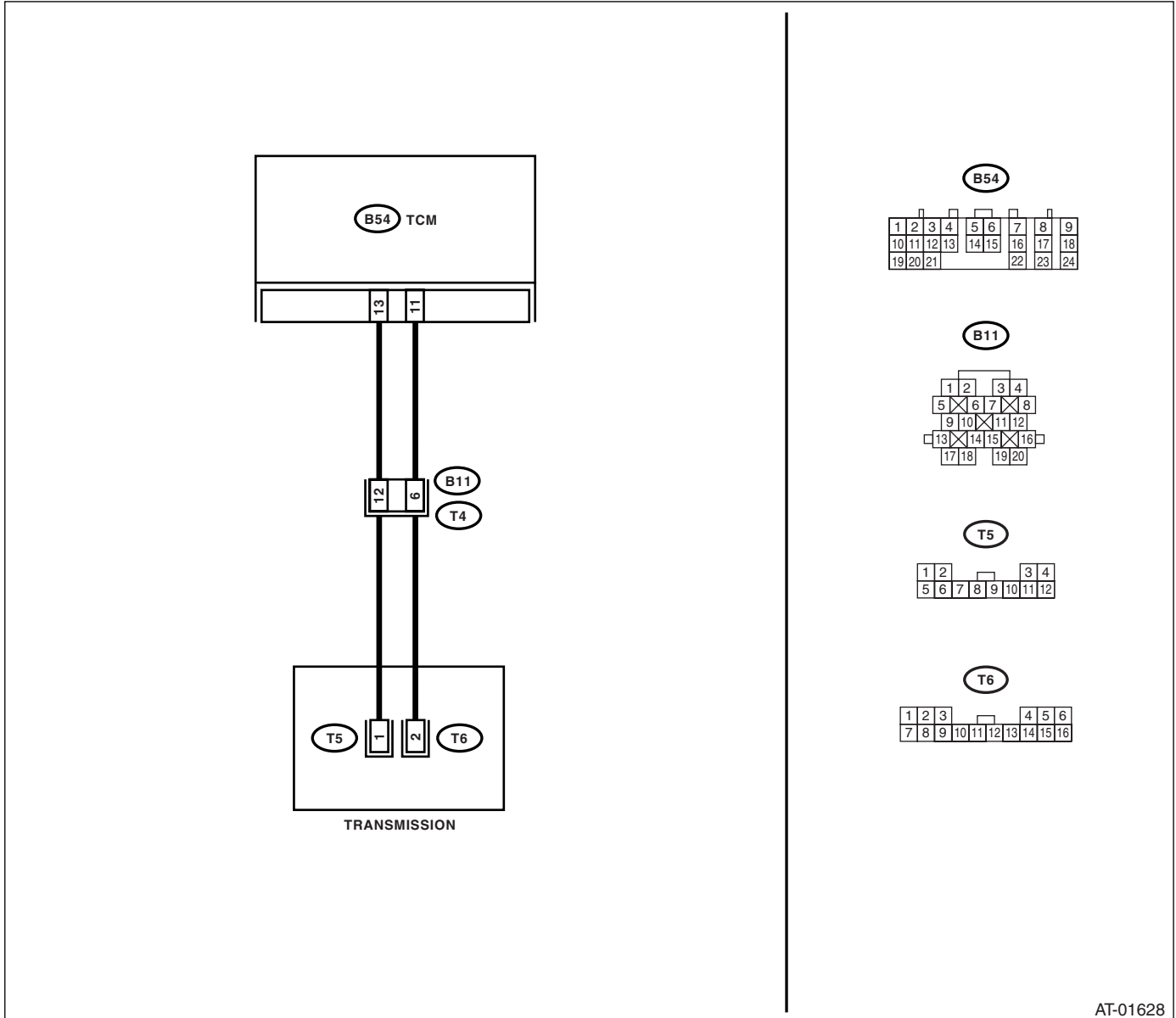

AT-01628

# Diagnostic Procedure with Diagnostic Trouble Code (DTC)

## AUTOMATIC TRANSMISSION (DIAGNOSTICS)

Step	Check	Yes	No
<b>1 CHECK HARNESS CONNECTOR BETWEEN TCM AND TRANSMISSION.</b> 1) Turn the ignition switch to OFF. 2) Disconnect the connectors from TCM and transmission. 3) Measure the resistance of harness between TCM connector and chassis ground. <b>Connector &amp; terminal</b> <b>(B54) No. 13 — (B11) No. 12:</b> <b>(B54) No. 11 — (B11) No. 6:</b>	Is the resistance more than 1 M $\Omega$ ?	Go to step 2.	Repair the short circuit of harness between TCM and transmission connector.
<b>2 CHECK ATF TEMPERATURE SENSOR.</b> 1) Turn the ignition switch to OFF. 2) Connect the connectors to transmission and TCM. 3) Turn the ignition switch to ON and start engine. 4) Warm-up the transmission until the ATF temperature reaches to 80°C (176°F). NOTE: If the ambient temperature falls below 0°C (32°F), drive the vehicle until the ATF reaches its operating temperature. 5) Disconnect the connector from transmission. 6) Measure the resistance between transmission connector terminals. <b>Connector &amp; terminal</b> <b>(T4) No. 6 — (T4) No.12:</b>	Is the resistance between 300 — 700 $\Omega$ ?	Go to step 3.	Go to step 5.
<b>3 CHECK ATF TEMPERATURE SENSOR.</b> Measure the resistance between transmission connector terminals. <b>Connector &amp; terminal</b> <b>(T4) No. 6 — (T4) No.12:</b>	Does the resistance value increase while the ATF temperature decreases?	Go to step 4.	Go to step 5.
<b>4 CHECK INPUT SIGNAL FOR TCM USING SUBARU SELECT MONITOR.</b> 1) Connect the connector. 2) Turn the ignition switch to ON. (Engine OFF) 3) Read the ATF temperature using Subaru Select Monitor.	Does the ATF temperature gradually decrease?	Even if the SPORT indicator light blinks, the system is in normal condition. A temporary poor contact of connector or harness may be the cause. Repair the poor contacts of harnesses of ATF temperature sensor and transmission connector.	Go to step 6.

# Diagnostic Procedure with Diagnostic Trouble Code (DTC)

AUTOMATIC TRANSMISSION (DIAGNOSTICS)

Step	Check	Yes	No
<p><b>5</b></p> <p><b>CHECK HARNESS CONNECTOR BETWEEN TRANSMISSION AND CONTROL VALVE BODY.</b></p> <p>1) Turn the ignition switch to OFF.                  2) Disconnect the connector from transmission.                  3) Remove the transmission connector from bracket.                  4) Lift-up the vehicle and place it on rigid racks.</p> <p>NOTE:                  Raise all wheels off floor.                  5) Drain the ATF.</p> <p><b>CAUTION:</b>  <b>Do not drain ATF until it cools down.</b></p> <p>6) Remove the oil pan, and disconnect the connector from control valve body connector.                  7) Measure the resistance between transmission ground and control valve body connector.</p> <p><b>Connector &amp; terminal</b>  <i>(T5) No. 1 — Chassis ground:</i>  <i>(T6) No. 2 — Chassis ground:</i></p>	<p>Is the resistance more than 1 MΩ?</p>	<p>Replace the control valve body.                  &lt;Ref. to 5AT-53, Control Valve Body.&gt;</p>	<p>Repair the short circuit of harness between transmission connector and control valve body connector.</p>
<p><b>6</b></p> <p><b>CHECK POOR CONTACT.</b></p> <p>Check poor contact of ATF temperature sensor 1 circuit.</p>	<p>Is there poor contact?</p>	<p>Repair the poor contact.</p>	<p>Replace the TCM.                  &lt;Ref. to 5AT-56, Transmission Control Module (TCM).&gt;</p>

## AM:DTC P1718 AT CAN COMMUNICATION CIRCUIT

NOTE:

DTC P1718 AT CAN communication circuit, refer to “LAN System”. <Ref. to LAN(diag)-12, READ DIAGNOSTIC TROUBLE CODE (DTC), OPERATION, Subaru Select Monitor.>

## AN:DTC P1798 GEAR 1 ENGINE BRAKE

NOTE:

Refer to DTC P0771 for diagnostic procedure. <Ref. to 5AT(diag)-82, DTC P0771 SHIFT SOLENOID “E” PERFORMANCE OR STUCK OFF, Diagnostic Procedure with Diagnostic Trouble Code (DTC).>

# Diagnostic Procedure with Diagnostic Trouble Code (DTC)

AUTOMATIC TRANSMISSION (DIAGNOSTICS)

## AO:DTC P1799 INTERLOCK

### DTC DETECTING CONDITION:

Perform the interlock judgment when the oil pressure switch pattern detects the specified interlock patterns other than shifting.

### TROUBLE SYMPTOM:

Locked to 2nd or 4th gear depending on the vehicle condition at the time of diagnosis.

	Step	Check	Yes	No
1	<b>CHECK DTC OF TCM.</b>	Is any DTC of the followings detected? P0751, P0753, P0756, P0758, P0761, P0763, P0766, P0768, P0771, P0773, P1798	Perform the diagnosis according to DTC.	Go to step 2.
2	<b>DRIVING CHECK.</b> 1) Turn the ignition switch to OFF. 2) After starting the engine again, perform a drive check with the following conditions. (1) Keep the speed at 20 km/h with SPORT shift mode in 1st. (2) Read the I/C oil pressure switch data of TCM while driving using Subaru Select Monitor.	Is OFF displayed?	Go to step 3.	Perform the diagnosis according to DTC P0756.
3	<b>DRIVING CHECK.</b> 1) Turn the ignition switch to OFF. 2) After starting the engine again, perform a drive check based on the inspection mode with the following conditions. <Ref. to 5AT(diag)-19, PROCEDURE, Inspection Mode.> (1) Keep the speed at 20 km/h with manual mode in 1st. (2) Read the D/C oil pressure switch data while driving using Subaru Select Monitor.	Is OFF displayed?	Go to step 4.	Perform the diagnosis according to DTC P0766.
4	<b>DRIVING CHECK.</b> 1) Turn the ignition switch to OFF. 2) After starting the engine again, perform a drive check with the following conditions. (1) Drive the vehicle at the same speed with manual mode in 3rd, 4th and 5th. (2) Read the LC/B oil pressure switch data while driving using Subaru Select Monitor.	Is OFF displayed?	Go to step 5.	Perform the diagnosis according to DTC P0771.
5	<b>DRIVING CHECK.</b> 1) Turn the ignition switch to OFF. 2) After restarting the engine, Perform a drive check based on the inspection mode. <Ref. to 5AT(diag)-19, PROCEDURE, Inspection Mode.>	Is DTC displayed?	Replace the control valve body.	Temporary poor contact occurs. Check that the harness connector is not faulty.

# Diagnostic Procedure with Diagnostic Trouble Code (DTC)

AUTOMATIC TRANSMISSION (DIAGNOSTICS)

## AP:DTC P1817 SPORT MODE SWITCH CIRCUIT (MANUAL SWITCH)

### DTC DETECTING CONDITION:

Input signal circuit of manual mode switch is open or shorted.

### TROUBLE SYMPTOM:

- Manual mode can not be set.
- "SPORT" light illuminates when shifting to "N" → "D" range.

### WIRING DIAGRAM:

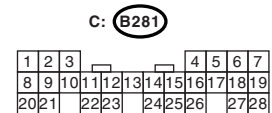
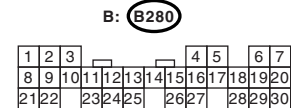
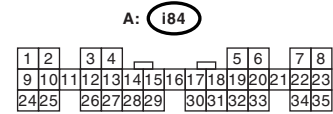
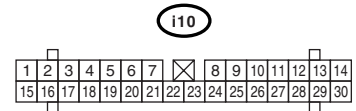
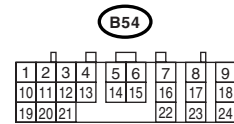
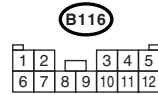
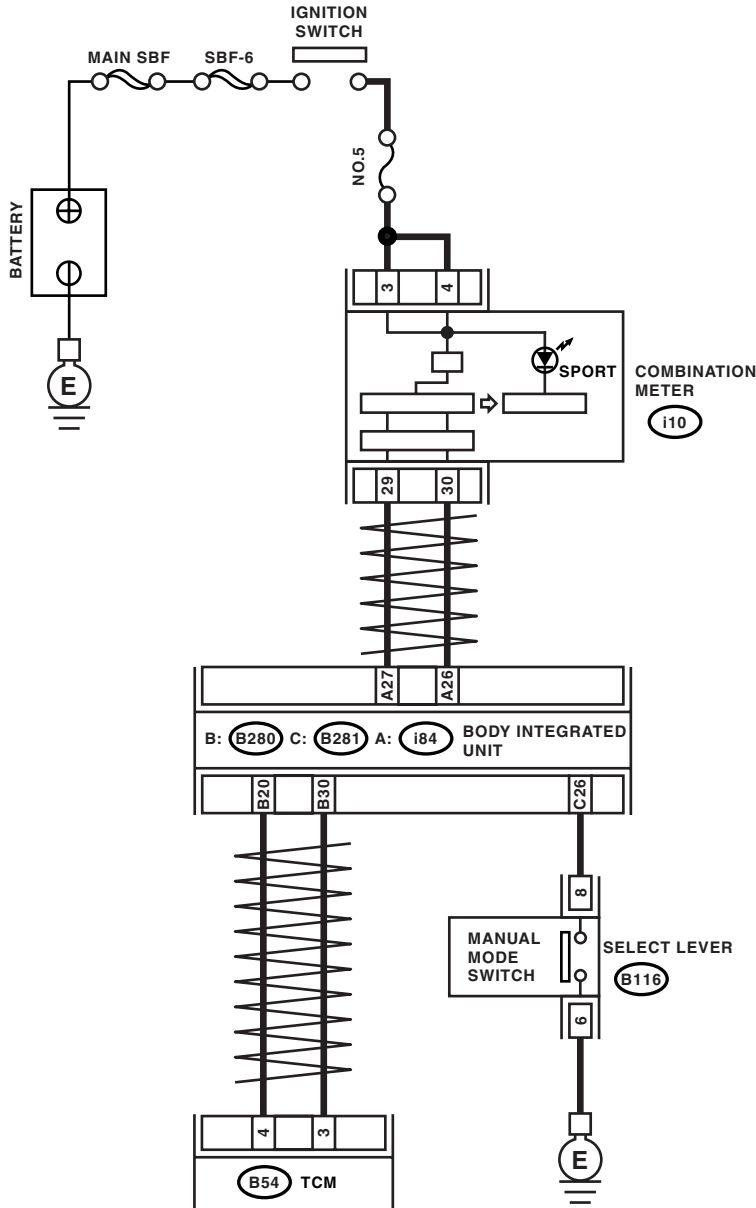

AT-03292

# Diagnostic Procedure with Diagnostic Trouble Code (DTC)

## AUTOMATIC TRANSMISSION (DIAGNOSTICS)

Step	Check	Yes	No
<b>1 CHECK THE BODY INTEGRATED UNIT.</b> 1) Connect the Subaru Select Monitor to data link connector. 2) Turn the ignition switch to ON. (Engine OFF) 3) Read the DTC of body integrated unit using Subaru Select Monitor. <Ref. to LAN(diag)-12, OPERATION, Subaru Select Monitor.>	Is DTC displayed?	Perform the diagnosis according to DTC.	Go to step 2.
<b>2 CHECK BODY INTEGRATED UNIT INPUT SIGNAL.</b> 1) Shift the select lever to shift to the "P" range. 2) Read the TIP mode SW data of body integrated unit using Subaru Select Monitor. <Ref. to LAN(diag)-12, OPERATION, Subaru Select Monitor.>	Is OFF displayed?	Go to step 3.	Go to step 7.
<b>3 CHECK BODY INTEGRATED UNIT INPUT SIGNAL.</b> 1) Shift the select lever from "P" to "D" range. 2) Read the TIP mode SW data of body integrated unit using Subaru Select Monitor. <Ref. to LAN(diag)-12, OPERATION, Subaru Select Monitor.>	Is the indication on each range OFF?	Go to step 4.	Replace the select lever assembly. <Ref. to CS-19, Select Lever.>
<b>4 CHECK BODY INTEGRATED UNIT INPUT SIGNAL.</b> 1) Shift the select lever to manual mode. 2) Shift the select lever to other than "D" range. 3) Read the TIP mode SW data of body integrated unit using Subaru Select Monitor. <Ref. to LAN(diag)-12, OPERATION, Subaru Select Monitor.>	Is OFF displayed?	Go to step 5.	Replace the select lever assembly. <Ref. to CS-19, Select Lever.>
<b>5 CHECK DTC OF TCM.</b>	Is DTC of Transmission Range Sensor Circuit (PRNDL Input) and AT CAN communication circuit displayed?	Perform the diagnosis according to each DTC.	Go to step 6.
<b>6 CHECK INPUT SIGNAL FROM TCM.</b> 1) Shift the select lever from "P" to "D" range. 2) Read the TIP mode SW data of TCM using Subaru Select Monitor. <Ref. to 5AT(diag)-15, OPERATION, Subaru Select Monitor.>	Is the indication on each range OFF?	Even if the SPORT indicator light blinks, the system is in normal condition. A temporary poor contact of connector or harness may be the cause.	Replace the TCM. <Ref. to 5AT-56, Transmission Control Module (TCM).>
<b>7 CHECK HARNESS BETWEEN BODY INTEGRATED UNIT AND MANUAL MODE SWITCH.</b> 1) Turn the ignition switch to OFF. 2) Disconnect harness connector from body integrated unit and select lever. 3) Measure the harness resistance between the body integrated unit and chassis ground. <b>Connector &amp; terminal</b> <b>(B281) No. 27 — Chassis ground:</b>	Is the resistance more than 1 MΩ?	Go to step 8.	Repair the short circuit of harness between body integrated unit and manual mode.



# Diagnostic Procedure with Diagnostic Trouble Code (DTC)

AUTOMATIC TRANSMISSION (DIAGNOSTICS)

Step	Check	Yes	No
<b>8</b> <b>CHECK MANUAL MODE SWITCH.</b> 1) Shift the select lever to shift to the "P" range. 2) Measure the resistance between harness connector terminals of manual mode switch. <i>Terminals</i> <i>(B116) No. 7 — No. 8</i>	Is the resistance more than 1 MΩ?	Check the body integrated unit.	Replace the select lever assembly. <Ref. to CS-19, Select Lever.>

## **AQ:DTC P1840 TRANSMISSION FLUID PRESSURE SENSOR/SWITCH A CIRCUIT**

### **DTC DETECTING CONDITION:**

Front brake oil pressure switch malfunction

### **TROUBLE SYMPTOM:**

Excessive shift shock

### **NOTE:**

Refer to DTC P0751 for diagnostic procedure. <Ref. to 5AT(diag)-61, DTC P0751 SHIFT SOLENOID "A" PERFORMANCE OR STUCK OFF, Diagnostic Procedure with Diagnostic Trouble Code (DTC).>

## **AR:DTC P1842 TRANSMISSION FLUID PRESSURE SENSOR/SWITCH C CIRCUIT**

### **DTC DETECTING CONDITION:**

Input clutch oil pressure switch is malfunction.

### **TROUBLE SYMPTOM:**

Excessive shift shock

### **NOTE:**

Refer to DTC P0756 for diagnostic procedure. <Ref. to 5AT(diag)-67, DTC P0756 SHIFT SOLENOID "B" PERFORMANCE OR STUCK OFF, Diagnostic Procedure with Diagnostic Trouble Code (DTC).>

## **AS:DTC P1843 TRANSMISSION FLUID PRESSURE SENSOR/SWITCH D CIRCUIT**

### **DTC DETECTING CONDITION:**

Direct clutch oil pressure switch malfunction.

### **TROUBLE SYMPTOM:**

Excessive shift shock

### **NOTE:**

Refer to DTC P0766 for diagnostic procedure. <Ref. to 5AT(diag)-77, DTC P0766 SHIFT SOLENOID "D" PERFORMANCE OR STUCK OFF, Diagnostic Procedure with Diagnostic Trouble Code (DTC).>

## **AT:DTC P1844 TRANSMISSION FLUID PRESSURE SENSOR/SWITCH E CIRCUIT**

### **DTC DETECTING CONDITION:**

High & low reverse clutch oil pressure switch malfunction.

### **TROUBLE SYMPTOM:**

Excessive shift shock

### **NOTE:**

Refer to DTC P0761 for diagnostic procedure. <Ref. to 5AT(diag)-72, DTC P0761 SHIFT SOLENOID "C" PERFORMANCE OR STUCK OFF, Diagnostic Procedure with Diagnostic Trouble Code (DTC).>