

34.AT Main Case

A: REMOVAL

- 1) Remove the transmission assembly from vehicle body. <Ref. to 5AT-34, REMOVAL, Automatic Transmission Assembly.>
- 2) Pull out the torque converter assembly. <Ref. to 5AT-62, REMOVAL, Torque Converter Assembly.>
- 3) Remove the transmission harness connector from stay.
- 4) Disconnect the air breather hose.
- 5) Remove the oil charge pipe. <Ref. to 5AT-61, REMOVAL, Oil Charge Pipe.>
- 6) Remove the ATF filter inlet and outlet pipes. <Ref. to 5AT-57, REMOVAL, ATF Cooler Pipe & Hose.>
- 7) Remove the extension case. <Ref. to 5AT-63, REMOVAL, Extension Case.>
- 8) Remove the center differential carrier. <Ref. to 5AT-71, REMOVAL, Center Differential Carrier.>
- 9) Remove the reduction driven gear. <Ref. to 5AT-68, REMOVAL, Reduction Driven Gear.>
- 10) Separate the converter case from the transmission case. <Ref. to 5AT-75, REMOVAL, Converter Case.>
- 11) Remove the control valve body. <Ref. to 5AT-53, REMOVAL, Control Valve Body.>
- 12) Remove the oil pump cover. <Ref. to 5AT-77, REMOVAL, Oil Pump Cover.>

NOTE:

The input clutch pack assembly and front sun gear assembly are also removed together.

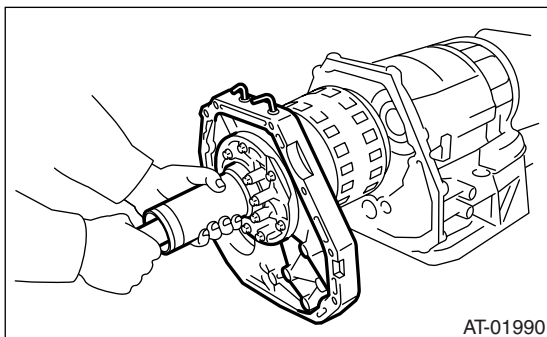

- 13) Remove the needle bearing of the middle carrier assembly.

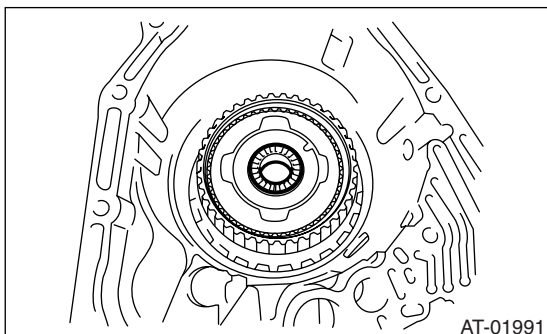

- 14) Remove the middle carrier assembly.

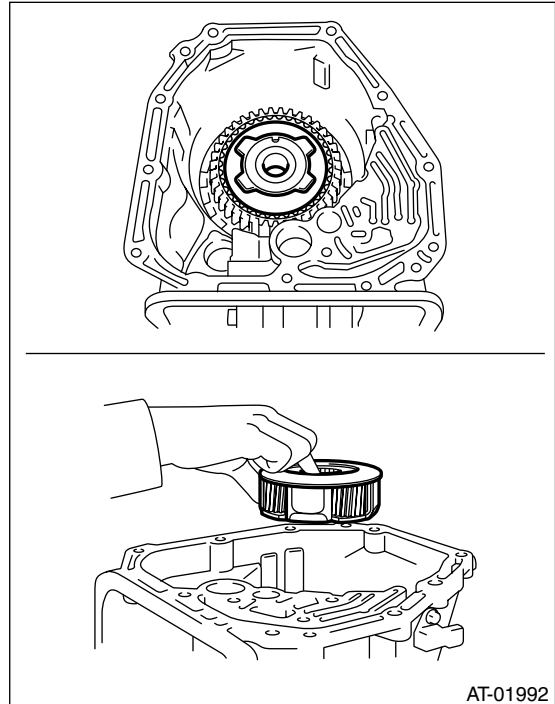

- 15) Remove the rear carrier assembly.

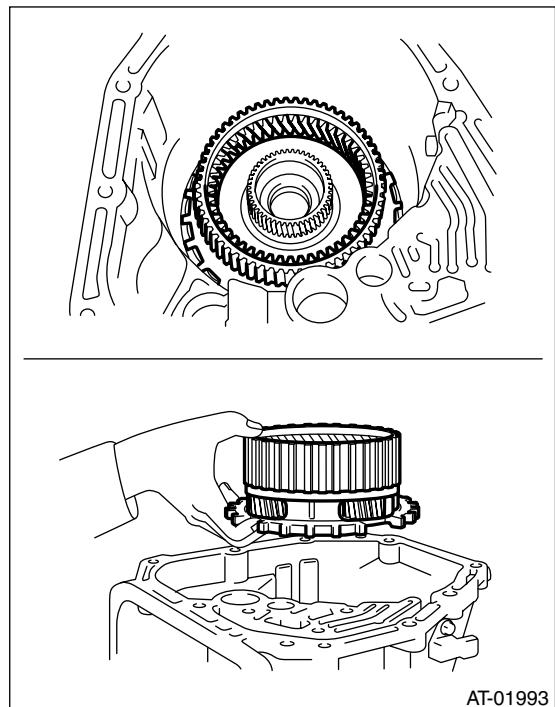

AT Main Case

AUTOMATIC TRANSMISSION

16) Remove the middle & rear sun gear assembly.

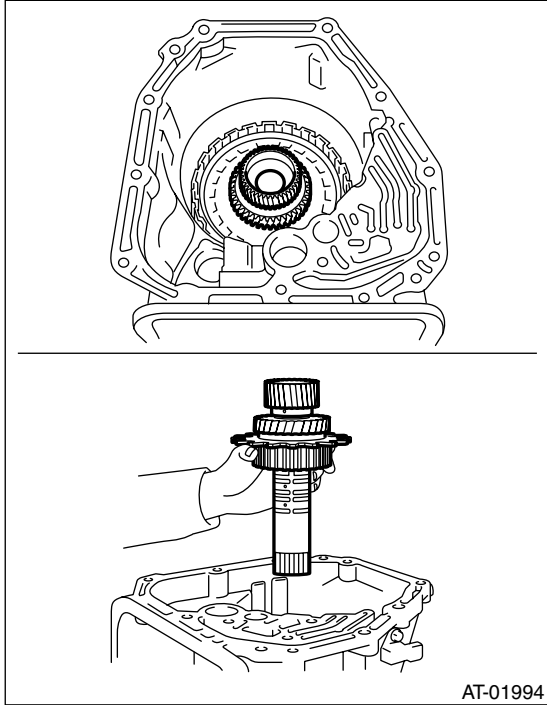

17) Remove the thrust needle bearing of high & low reverse clutch.

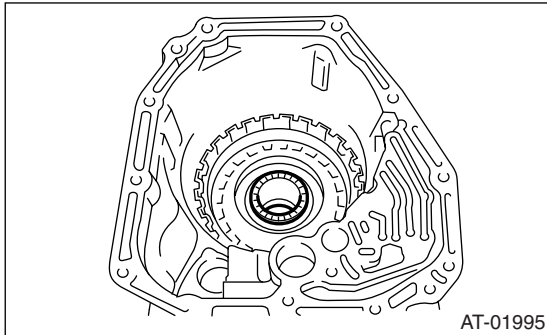

18) Remove the high & low reverse clutch assembly.

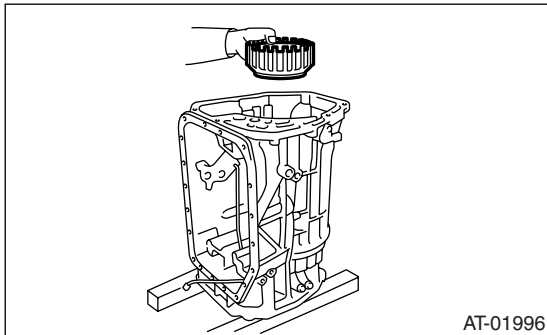

19) Remove the direct clutch assembly.

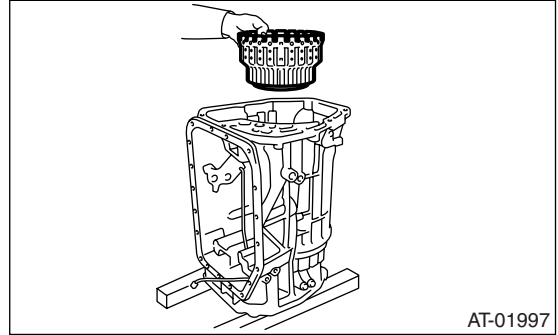

20) Remove the snap ring of reverse brake.

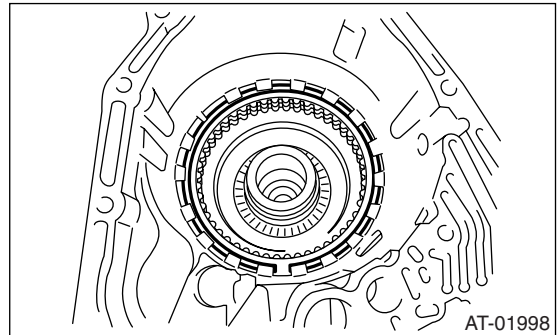

21) Remove the retaining plate.

22) Remove the leaf spring.

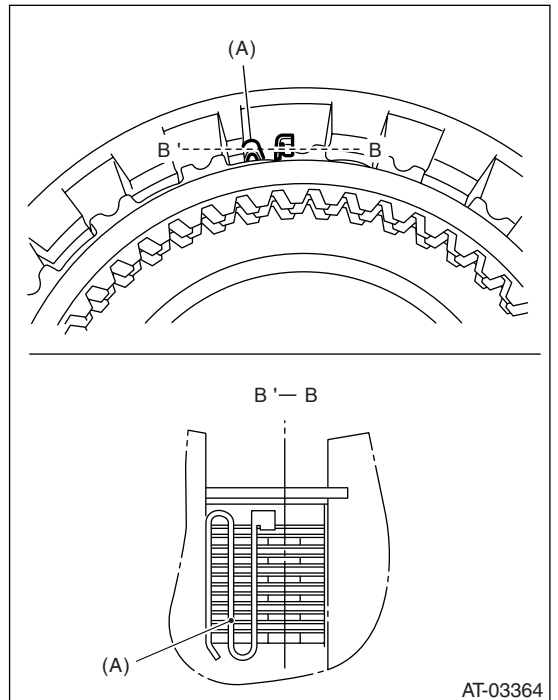

(A) Leaf spring

23) Take out the drive plate, driven plate and dish plate.

24) Remove the snap ring of the reverse brake spring retainer.

ST1 18762AA000 COMPRESSOR SPECIAL TOOL

ST2 18765AA000 COMPRESSOR SUPPORT

ST3 18763AA000 COMPRESSOR SHAFT

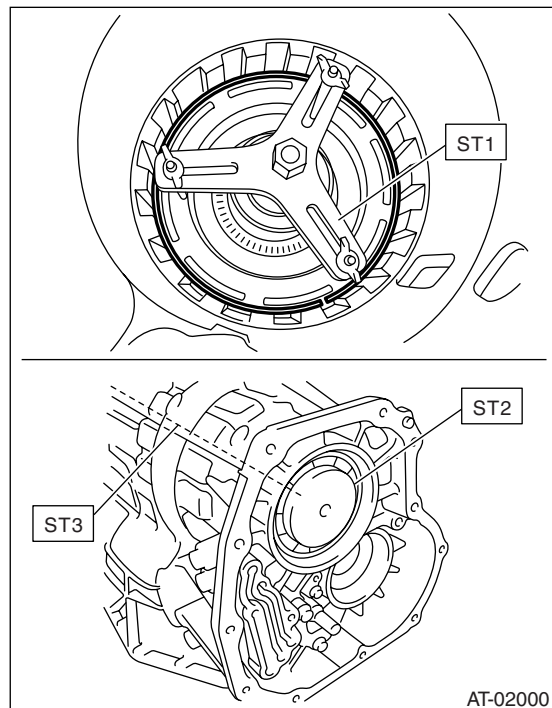

25) Remove the spring retainer.

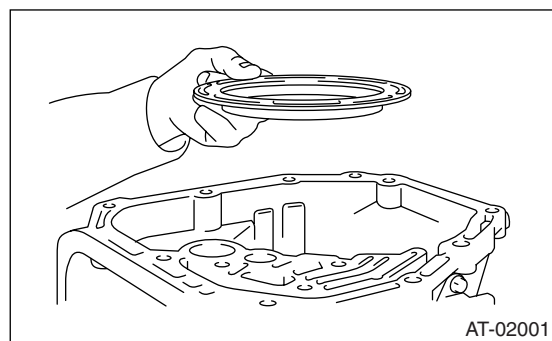

26) Remove the return spring.

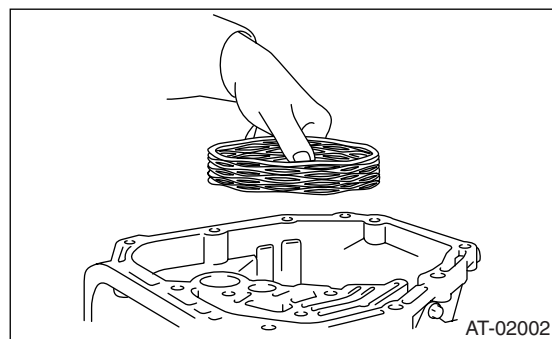

27) Apply compressed air.

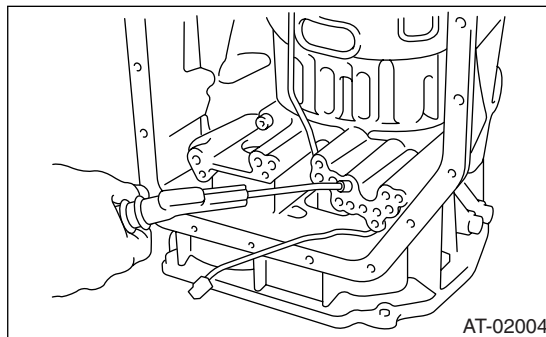

28) Remove the reverse brake piston.

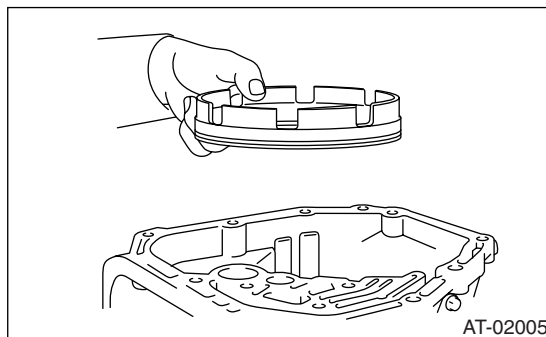

B: INSTALLATION

1) Install the reverse brake piston.

NOTE:

Apply ATF onto the piston sliding surface.

ST1 18762AA000 COMPRESSOR SPECIAL TOOL

ST2 18765AA000 COMPRESSOR SUPPORT

ST3 18763AA000 COMPRESSOR SHAFT

2) Install the return spring.

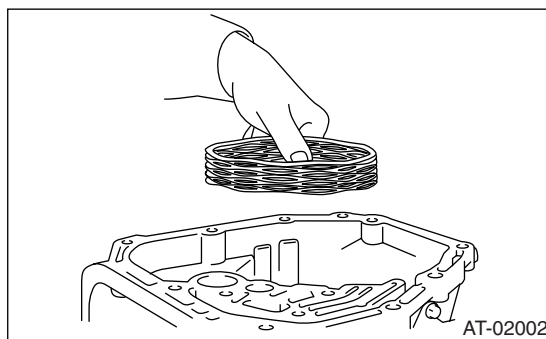

AT Main Case

AUTOMATIC TRANSMISSION

- 3) Install the spring retainer and snap ring.
 ST1 18762AA000 COMPRESSOR SPECIAL TOOL
 ST2 18765AA000 COMPRESSOR SUPPORT
 ST3 18763AA000 COMPRESSOR SHAFT

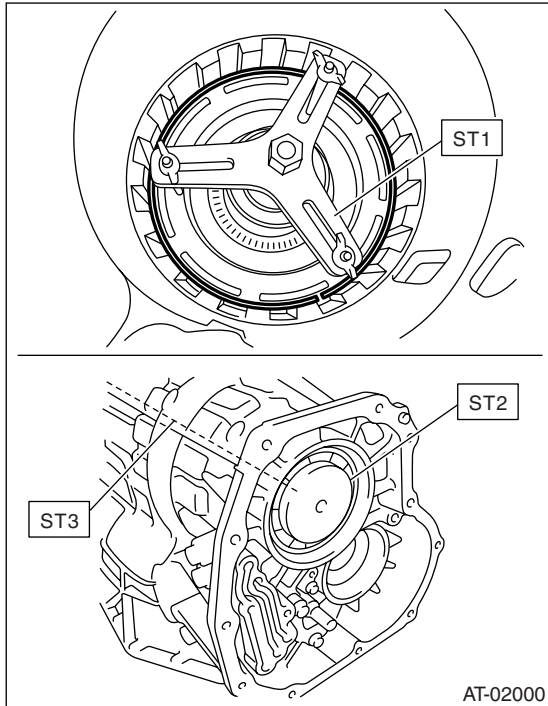

- 4) Install the dish plate.

NOTE:

When installing, make sure that the identification mark is facing the front side of transmission.

- 5) Install the drive plate and driven plate.
 6) Install the leaf spring.

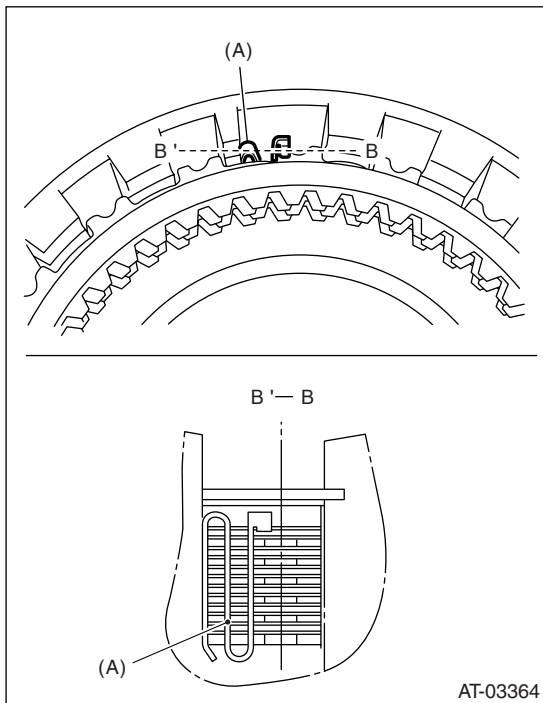

(A) Leaf spring

- 7) Install the retaining plate.
 8) Install the snap ring of the reverse brake.

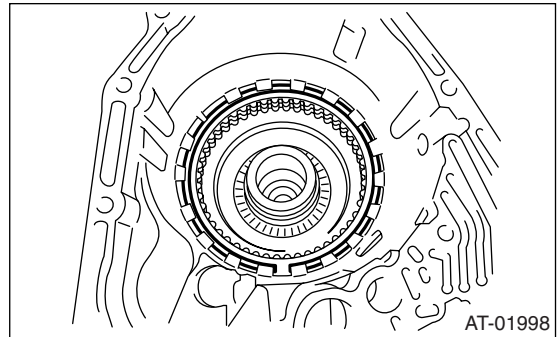

- 9) Perform the clearance check of reverse brake.
 (1) Measure the clearance between retainer plate and snap ring using thickness gauge.

Specification:

0.7 — 1.1 mm (0.028 — 0.043 in)

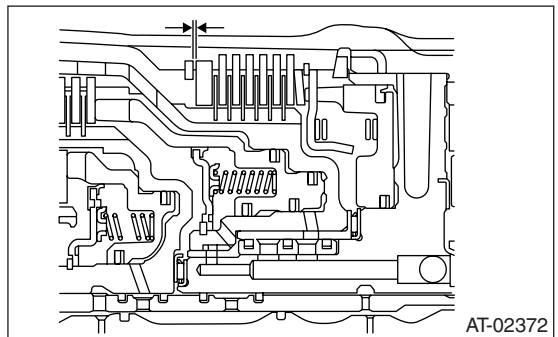

- (2) If it is out of specification, select a suitable retainer plate from the following table and assemble it.

Retainer plate	
Part No.	Thickness mm (in)
31567AB100	4.2 (0.165)
31567AB170	4.4 (0.173)
31567AB180	4.6 (0.181)
31567AB190	4.8 (0.189)
31567AB200	5.0 (0.197)

- 10) Install the direct clutch assembly.

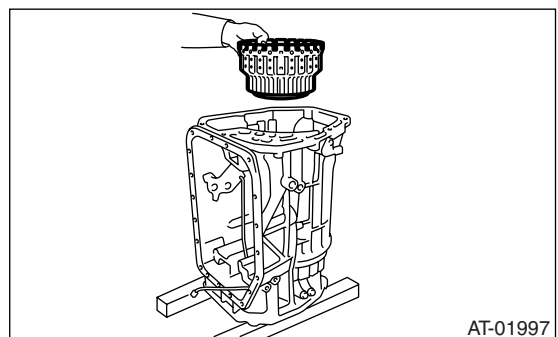

11) Install the high & low reverse clutch assembly.

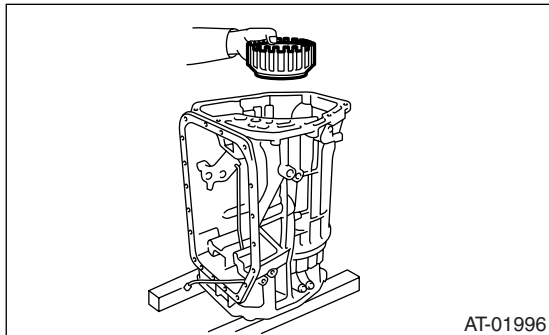

AT-01996

12) Install the thrust needle bearing of the high & low reverse clutch.

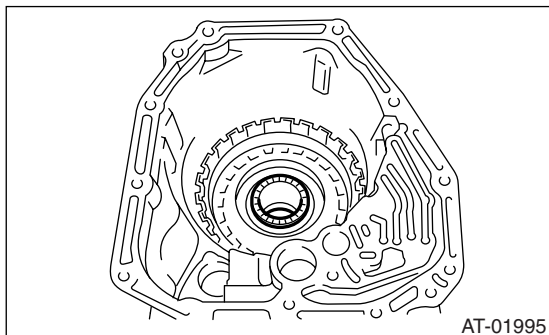

AT-01995

13) Install the middle & rear sun gear assembly.

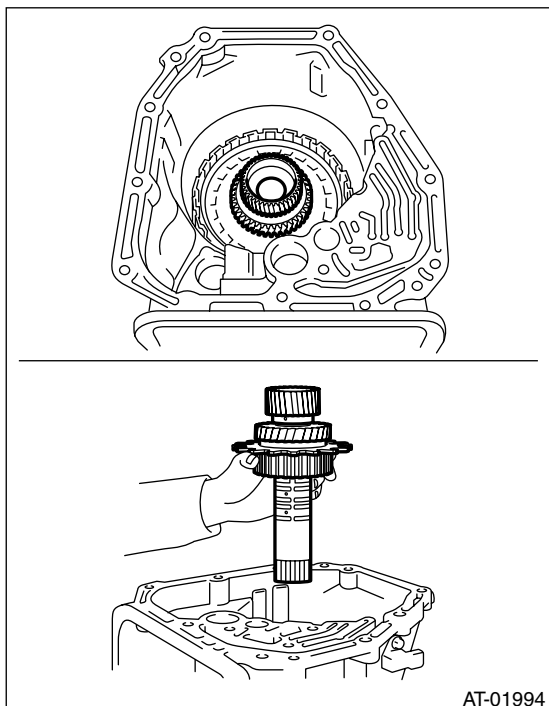

AT-01994

14) Install the rear carrier assembly.

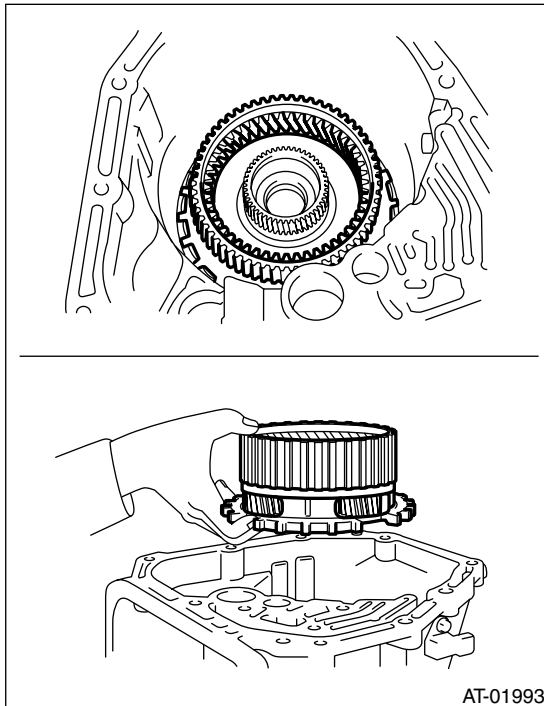

AT-01993

15) Install the middle carrier assembly.

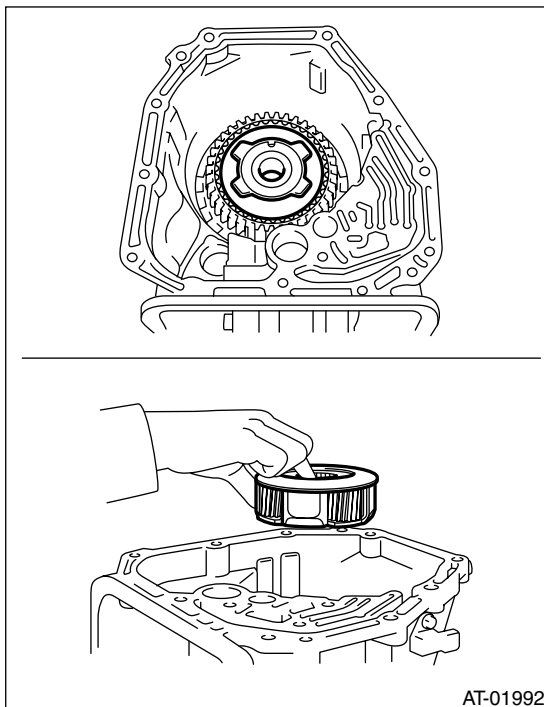

AT-01992

AT Main Case

AUTOMATIC TRANSMISSION

16) Install the thrust needle bearing of middle carrier assembly.

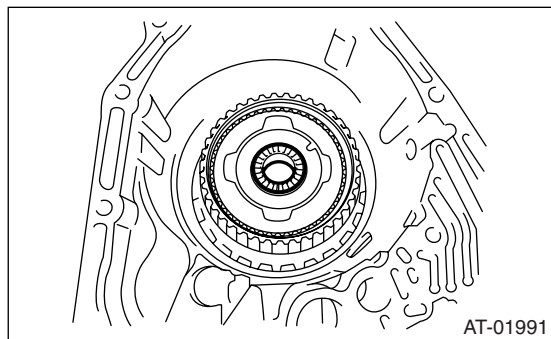

17) Measure the total end play, and select the bearing. <Ref. to 5AT-99, ADJUSTMENT, AT Main Case.>

18) Install the impact clutch pack assembly to oil pump cover.

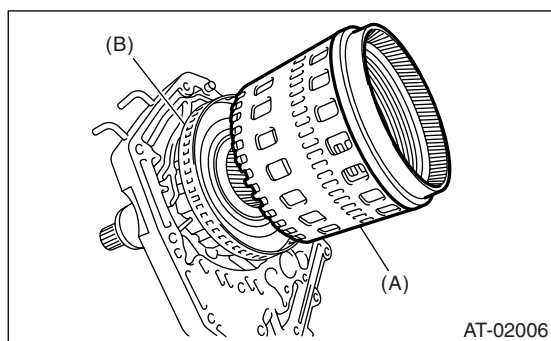

- (A) Impact clutch pack ASSY
- (B) Front sun gear ASSY

19) Install the thrust needle bearing.

20) Turn the transmission sideways.

21) Install the oil pump cover.

- (1) Apply ATF to the O-ring of input clutch shaft.
- (2) Install the oil pump cover to AT main case while supporting the input clutch shaft and oil pump housing with your hand.

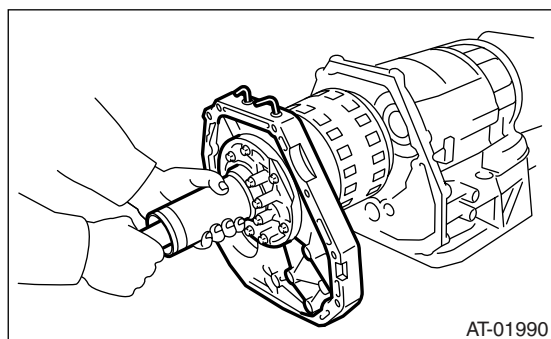

(3) Make sure the rear end of drive pinion shaft is engaged to the spline of reduction driven gear.

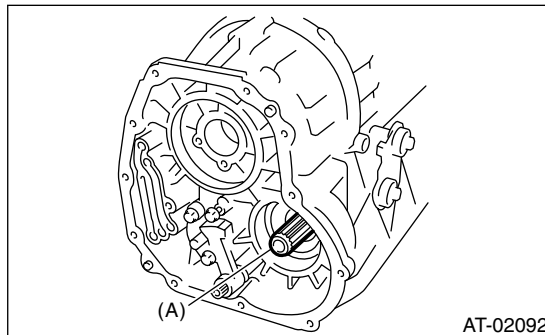

- (A) Drive pinion shaft

(4) Protect the input clutch shaft with a cloth, and rotate to engage the spline of the input clutch and rear carrier using pliers.

NOTE:

Work with pressing the oil pump cover.

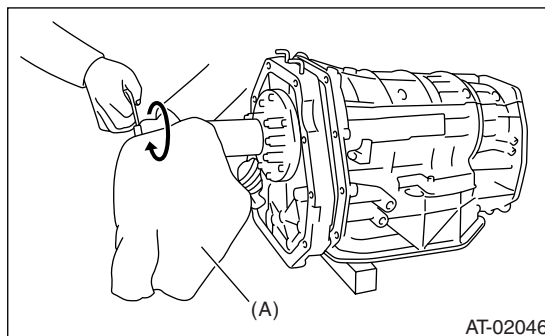

- (A) Cloth

(5) Combine the oil pump cover with transmission main case.

Tightening torque:

41 N·m (4.2 kgf·m, 30.4 ft·lb)

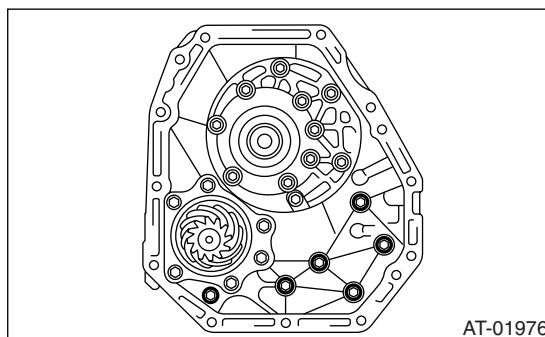

22) Install the center differential carrier. <Ref. to 5AT-71, INSTALLATION, Center Differential Carrier.>

23) Install the reduction driven gear. <Ref. to 5AT-68, INSTALLATION, Reduction Driven Gear.>

24) Install the extension case. <Ref. to 5AT-63, INSTALLATION, Extension Case.>

25) Install the control valve body. <Ref. to 5AT-53, INSTALLATION, Control Valve Body.>

26) Install the converter case assembly to the transmission case assembly. <Ref. to 5AT-75, INSTALLATION, Converter Case.>

27) Install the air breather hose. <Ref. to 5AT-60, INSTALLATION, Air Breather Hose.>

28) Install the ATF filter pipe. <Ref. to 5AT-58, INSTALLATION, ATF Cooler Pipe & Hose.>

29) Install the oil charge pipe together with an O-ring. <Ref. to 5AT-61, INSTALLATION, Oil Charge Pipe.>

30) Install the torque converter assembly. <Ref. to 5AT-62, INSTALLATION, Torque Converter Assembly.>

31) Install the transmission assembly to the vehicle. <Ref. to 5AT-37, INSTALLATION, Automatic Transmission Assembly.>

32) Perform Clear Memory 2 operation. <Ref. to 5AT(diag)-17, CLEAR MEMORY MODE, OPERATION, Subaru Select Monitor.>

33) Perform the inspection with driving the vehicle at the end of repair work, and make sure there is no faulty as below;

- Excessive shift shock
- Oil leakage from the transmission body, etc.
- Occurrence of noise caused by interference etc.

NOTE:

If excessive shift shock is felt, execute advance operation of learning control. <Ref. to 5AT(diag)-21, PROCEDURE, Learning Control.>

C: DISASSEMBLY

1. INPUT CLUTCH PACK ASSEMBLY

1) Remove the front sun gear.

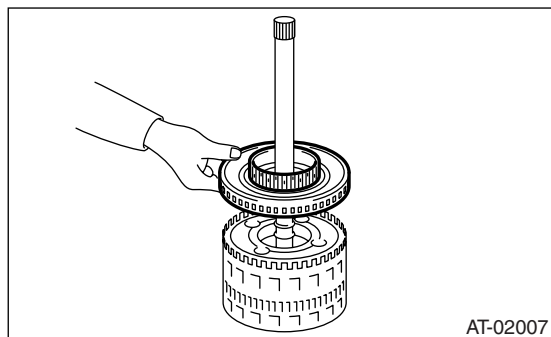

2) Remove the thrust bearing.

3) Remove the snap ring, and then remove the front carrier.

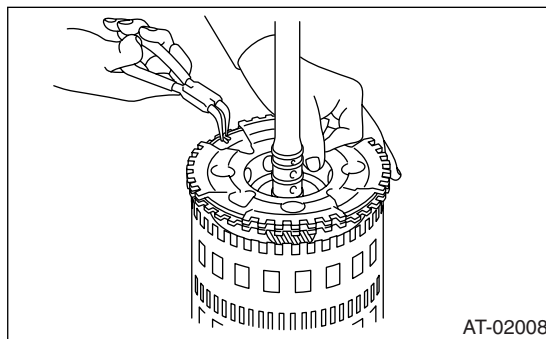

4) Remove the input clutch assembly from rear internal gear.

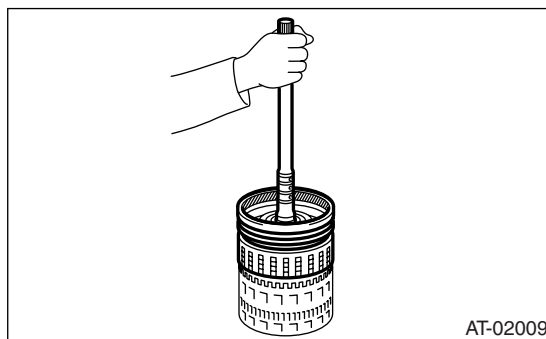

D: ASSEMBLY

1. INPUT CLUTCH PACK ASSEMBLY

1) Assemble the input clutch assembly to rear internal gear.

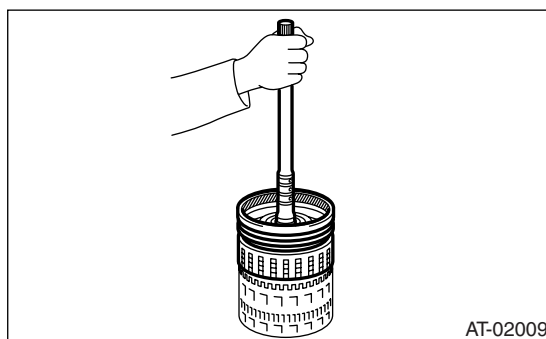

2) Install the front carrier, and then install the snap ring.

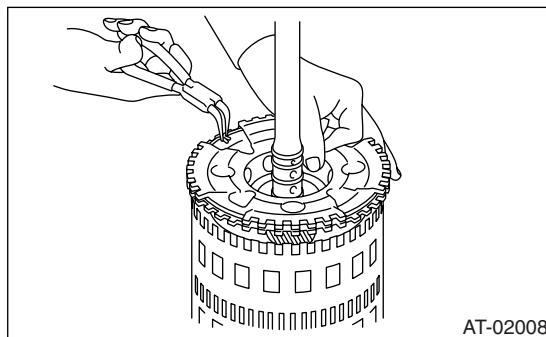

AT Main Case

AUTOMATIC TRANSMISSION

- 3) Install the thrust needle bearing.
- 4) Install the front sun gear.

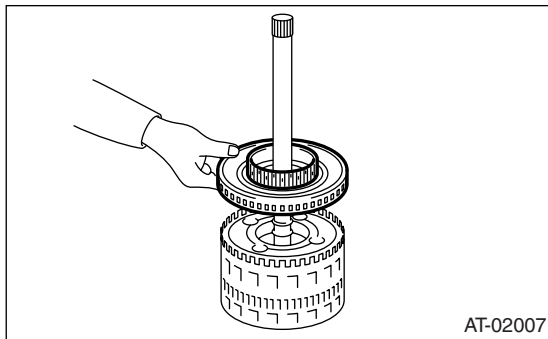

E: INSPECTION

1. FRONT, MIDDLE & REAR PLANETARY CARRIER ASSEMBLY

Check the following items.

- Visually inspect the tooth surface of planetary gear, and replace with new one if damaged, broken or excessively worn.
- Inspect the planetary carrier body for damage or breakage.

2. INPUT CLUTCH

- Check the clearance of the input clutch. Measure the clearance “L” between snap ring and retaining plate using a thickness gauge. If it is out of specification, replace the entire direct clutch assembly.
- Check for damage on the drive plate, driven plate and snap ring, and replace the entire input clutch assembly if damaged.

Specification:

0.7 — 1.1 mm (0.028 — 0.043 in)

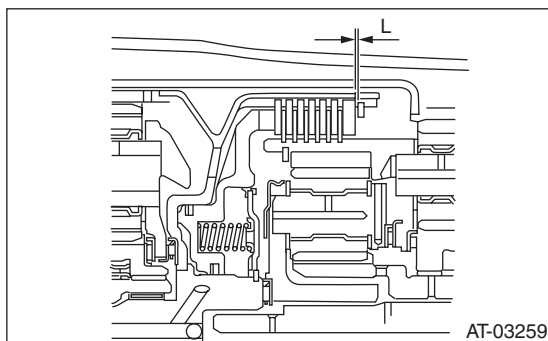

3. HIGH & LOW REVERSE CLUTCH ASSEMBLY

- Check the clearance of the high & low reverse clutch.

Measure the clearance “L” between snap ring and retaining plate using a thickness gauge. If it is out of specification, replace the entire high & low reverse clutch assembly.

- Check for damage on the drive plate, driven plate and snap ring, and replace the entire high & low reverse clutch assembly if damaged.

Specification:

1.8 — 2.2 mm (0.070 — 0.087 in)

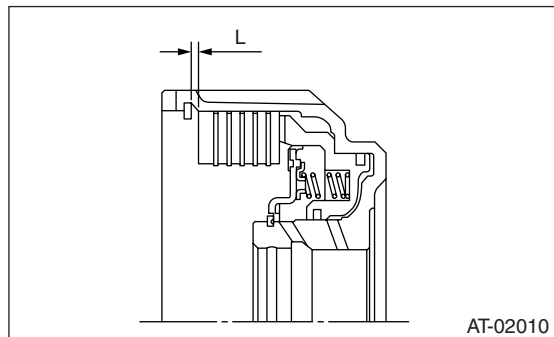

4. DIRECT CLUTCH ASSEMBLY

- Check the clearance of direct clutch. Measure the clearance “L” between snap ring and retaining plate using a thickness gauge. If it is out of specification, replace them as direct clutch assembly.
- Check for damage on the drive plate, driven plate and snap ring, and replace the entire direct clutch assembly if damaged.

Specification:

0.6 — 1.0 mm (0.024 — 0.039 in)

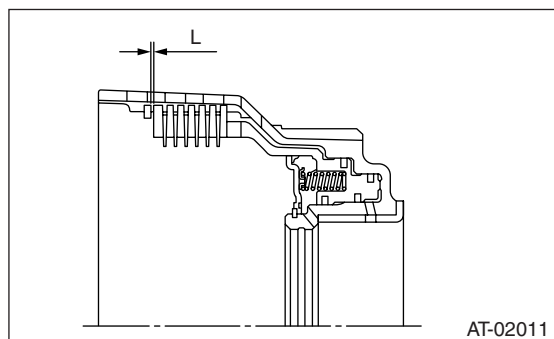

5. REVERSE BRAKE

Check the following items.

- Drive plate facing for wear or damage
- Snap ring for wear, return spring for breakage, and spring retainer for deformation
- Lip seal and D-ring for damage
- Piston operation

F: ADJUSTMENT

1) Using the ST, measure the height "A" from the AT main case mating surface to convex surface of oil pump cover.

ST 499575400 GAUGE

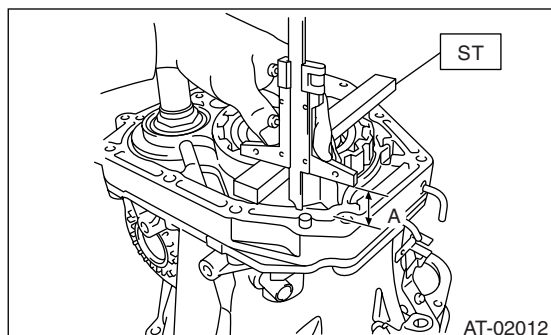

2) Using the ST, measure the depth "B" from the convex surface of oil pump cover to thrust bearing transferring surface.

ST 499575400 GAUGE

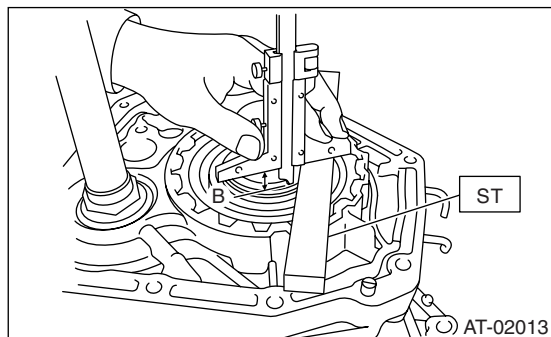

3) Calculate the measured value from step 1) and 2), and then set the calculated value as "C"

Calculation formula: $C = A - B$

4) Using the ST, measure the depth "D" from the AT main case mating surface to thrust bearing transferring surface of front sun gear.

ST 499575400 GAUGE

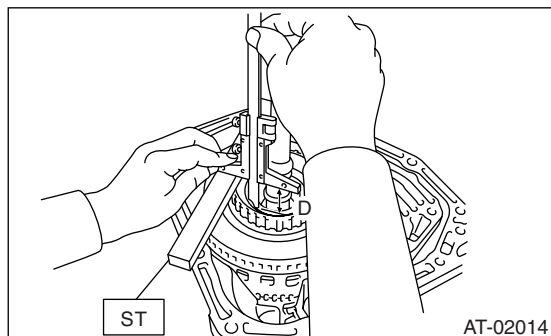

5) Set the value as "E" which subtract the thickness of ST (GAUGE) from the measured value on step 4).

Calculation formula: $E \text{ (mm)} = D - 15$

$[E \text{ (in)} = D - 0.59]$

6) Calculation formula:

Select one thrust bearing from the table to adjust clearance within 0.25 — 0.55 mm (0.0098 — 0.022 in).

When clearances are 0.25 mm (0.0098 in):

$T \text{ (mm)} = E - C + 0.03$

$[T \text{ (in)} = E - C + 0.0012]$

When clearances are 0.55 mm (0.022 in):

$T \text{ (mm)} = E - C - 0.27$

$[T \text{ (in)} = E - C - 0.012]$

T: Thrust needle bearing thickness

C: Distance from oil pump cover mating surface to rear end of oil pump cover

E: Depth from mating surface of AT main case to bearing surface of front sun gear

NOTE:

Calculation formula for "T" above is applied when measuring with the ST (499575400 GAUGE). In the calculation without using ST, substitute the thickness of collar used to calculate the value "E" on step 5).

Thrust bearing	
Part No.	Thickness mm (in)
806548020	3.2 (0.126)
606548030	3.4 (0.134)
806548040	3.6 (0.142)
806548050	3.8 (0.150)
806548060	4.0 (0.157)
806548070	4.2 (0.165)