

Automatic Transmission Assembly

AUTOMATIC TRANSMISSION

9. Automatic Transmission Assembly

A: REMOVAL

- 1) Set the vehicle on a lift.
- 2) Open the front hood and support with the hood stay.
- 3) Disconnect the ground cable from battery.
- 4) Remove the collector cover.
- 5) Remove the air intake chamber. <Ref. to IN(H6DO)-6, REMOVAL, Air Intake Chamber.>
- 6) Remove the air breather hose. <Ref. to 5AT-60, REMOVAL, Air Breather Hose.>
- 7) Remove the starter. <Ref. to SC(H6DO)-6, REMOVAL, Starter.>
- 8) Disconnect the front oxygen (A/F) sensor and transmission harness connector.

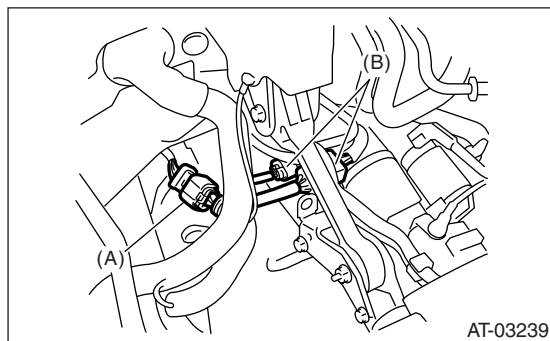

- (A) Front oxygen (A/F) sensor
- (B) Transmission harness connectors

- 9) Disconnect the engine harness connectors, and then remove the engine hanger rear.

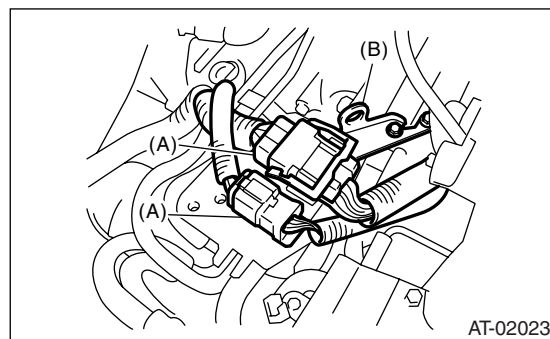

- (A) Engine harness connectors
- (B) Engine hanger rear

- 10) Remove the vacuum pipe & hose assembly and the brake vacuum pump. <Ref. to BR-39, REMOVAL, Brake Vacuum Pump.>

- 11) Remove the throttle body securing bolts to and slide the throttle body over.

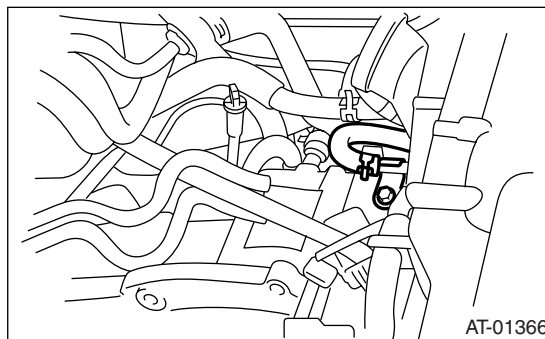

- 12) Separate the torque converter from drive plate.
 - (1) Remove the service hole plug.
 - (2) Remove the bolts which hold torque converter to drive plate.
 - (3) Remove the four bolts by rotating the clamp pulley a little at a time.
 - (4) Make sure the torque converter moves freely by rotating with finger through the starter installation hole.

CAUTION:
Be careful not to drop bolts into converter housing.

- 13) Install the ST to the converter case.
ST 498277200 STOPPER SET

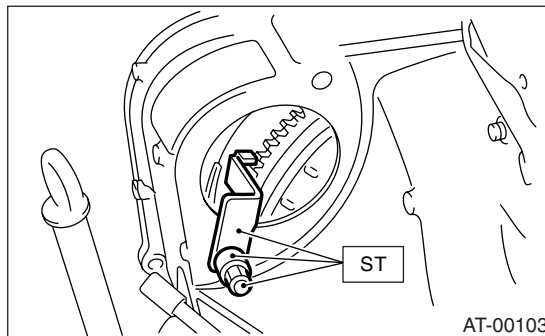

- 14) Remove the pitching stopper.

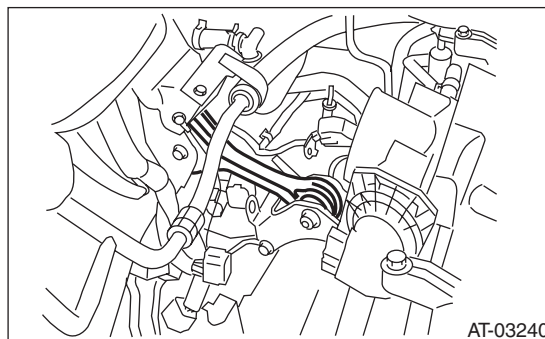

Automatic Transmission Assembly

AUTOMATIC TRANSMISSION

15) Remove the pitching stopper bracket.

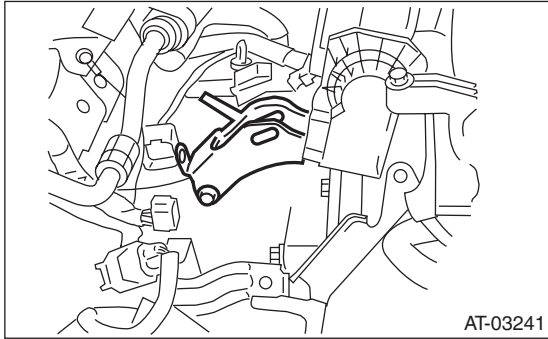

16) Set the ST.

ST1 41099AA010 ENGINE SUPPORT BRACKET

ST2 41099AA020 ENGINE SUPPORT

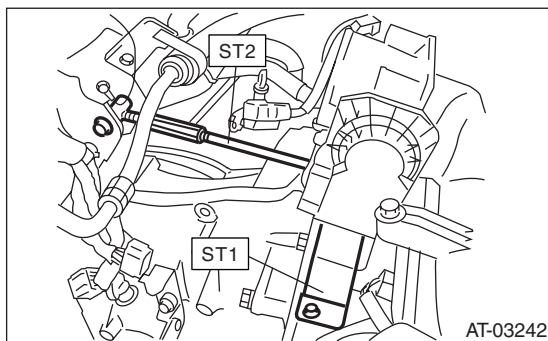

17) Remove the transmission mounting bolt (upper side).

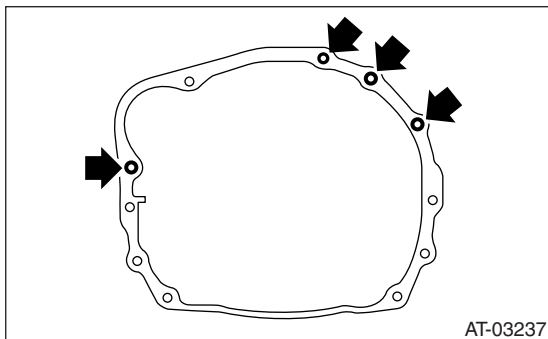

18) Lift-up the vehicle.

19) Remove the under cover.

20) Remove the front exhaust pipe, rear exhaust pipe and muffler. <Ref. to EX(H6DO)-4, REMOVAL, Front Exhaust Pipe.> <Ref. to EX(H6DO)-6, REMOVAL, Rear Exhaust Pipe.> <Ref. to EX(H6DO)-8, REMOVAL, Muffler.>

21) Remove the heat shield cover.

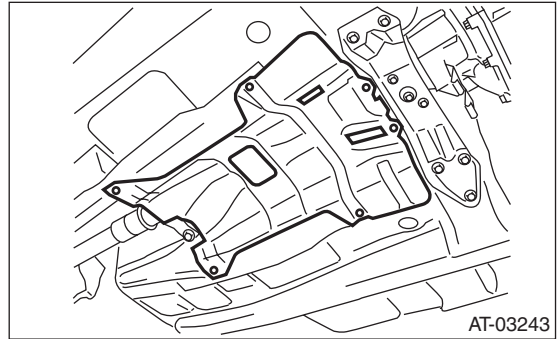

22) Remove the ATF drain plug to drain ATF.

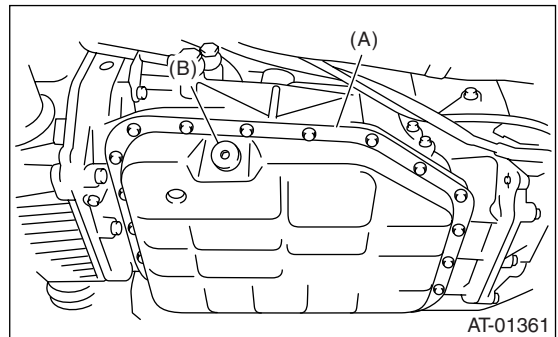

(A) Oil pan

(B) Drain plug

23) Remove the oil charge pipe.

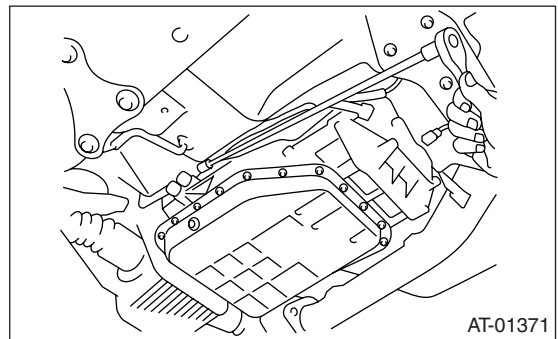

24) Disconnect the connector from turbine speed sensor 1.

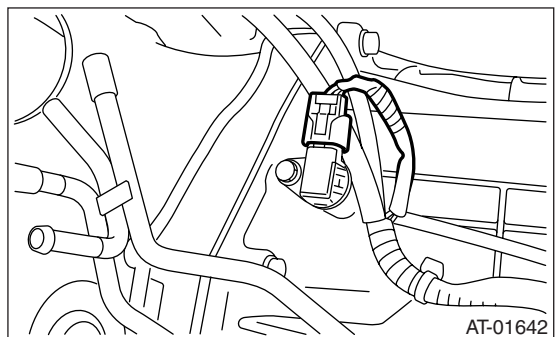

Automatic Transmission Assembly

AUTOMATIC TRANSMISSION

25) Remove the turbine speed sensor 1 from the transmission body.

CAUTION:

Failure to follow this procedure may cause the interference between vehicle body and sensor while removing/installing transmission, and resulting in damage.

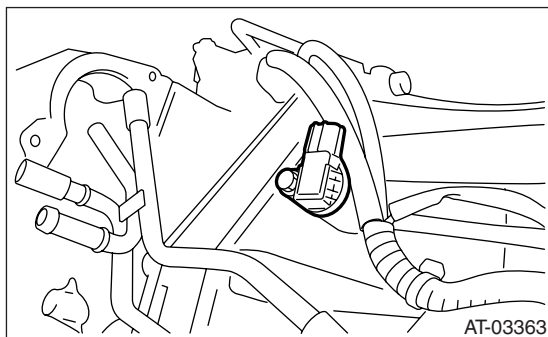

26) To prevent contamination by foreign objects, cover the attachment hole for turbine speed sensor 1 with vinyl tape.

27) Remove the propeller shaft. <Ref. to DS-10, REMOVAL, Propeller Shaft.>

28) Remove the shift select cable. <Ref. to CS-26, REMOVAL, Select Cable.>

29) Disconnect the hose from the ATF inlet and outlet pipes.

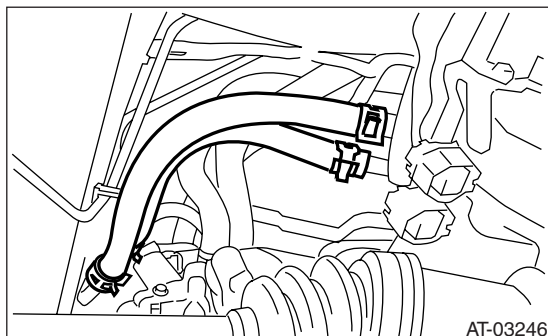

30) Remove the front crossmember support plate. <Ref. to FS-13, REMOVAL, Front Crossmember Support Plate.>

31) Remove the two clutch housing cover securing bolts.

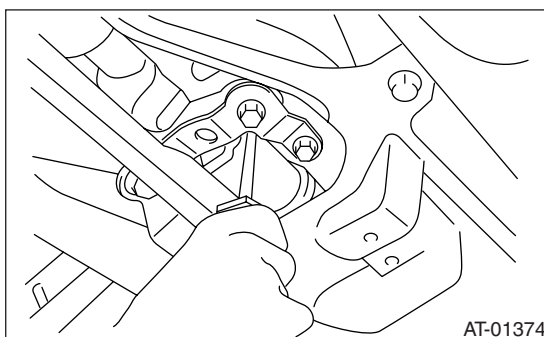
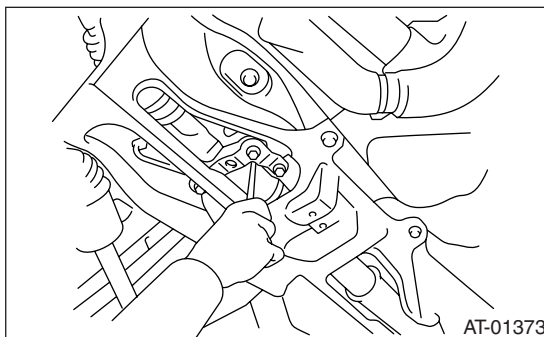

32) Remove the front stabilizer clamp. <Ref. to FS-14, REMOVAL, Front Stabilizer.>

33) Remove the bolts which secure front ball joint to the housing. <Ref. to FS-15, REMOVAL, Front Ball Joint.>

34) Pull out the drive shaft from transmission.

35) Set the transmission jack under the transmission.

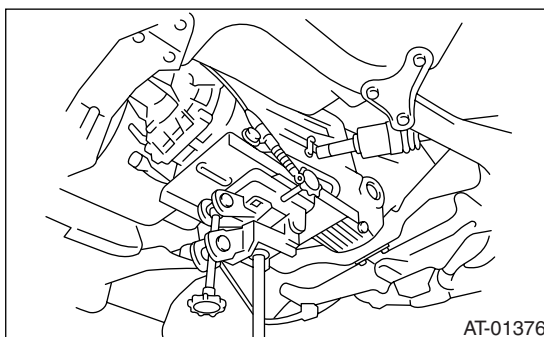

36) Remove the rear crossmember.

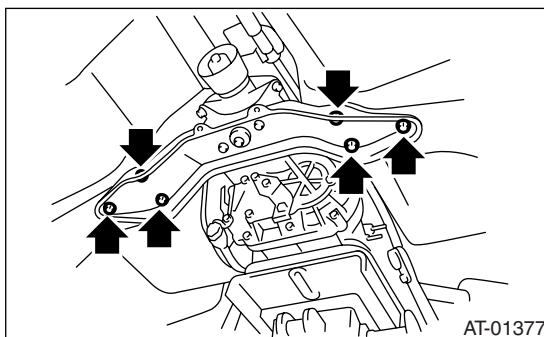

37) Remove the transmission mounting bolts and nuts (lower side).

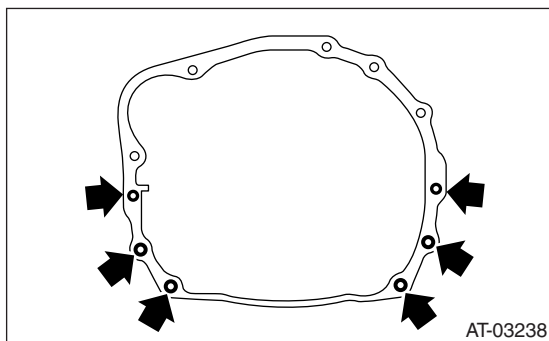

38) Remove the transmission.

NOTE:

- Turn the engine support assembly from the vehicle under body to the left (to shorten the engine support length), and lower the rear of the engine for easy disassembly.
- Be careful not to allow breather pipe and etc. to touch the vehicle body when detaching the automatic transmission assembly by pulling it backward.

B: INSTALLATION

1) Install the ST to converter case.
ST 498277200 STOPPER SET

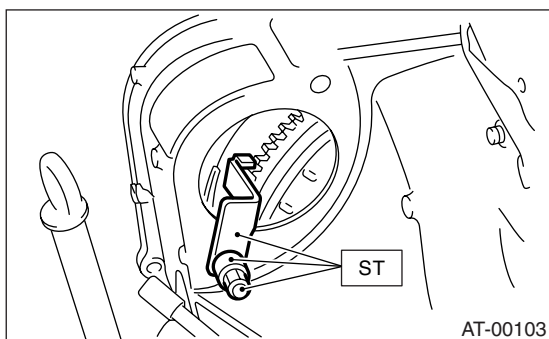

2) Install the transmission onto the engine.
3) Install the engine mounting bolts and nuts (lower side).

Tightening torque:
50 N·m (5.1 kgf-m, 36.9 ft-lb)

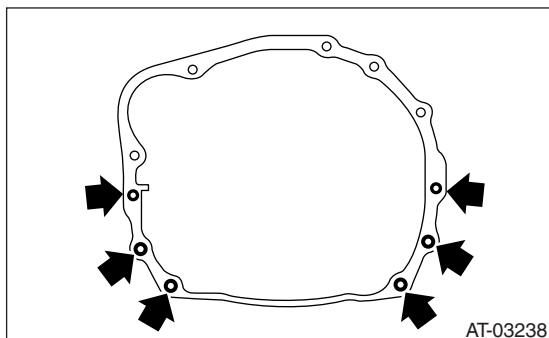

4) Install the transmission rear crossmember.

Tightening torque:
75 N·m (7.6 kgf-m, 55.3 ft-lb)

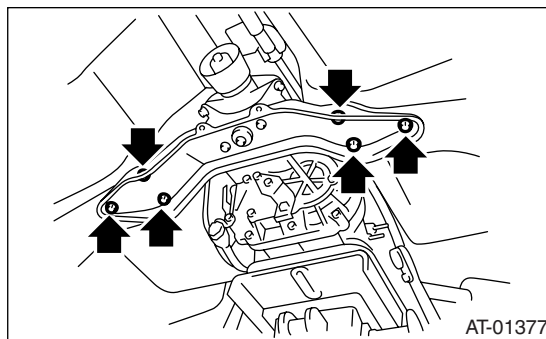

5) Remove the transmission jack.
6) Lower the vehicle.
7) Install the engine mounting bolt (upper side).

Tightening torque:
50 N·m (5.1 kgf-m, 36.9 ft-lb)

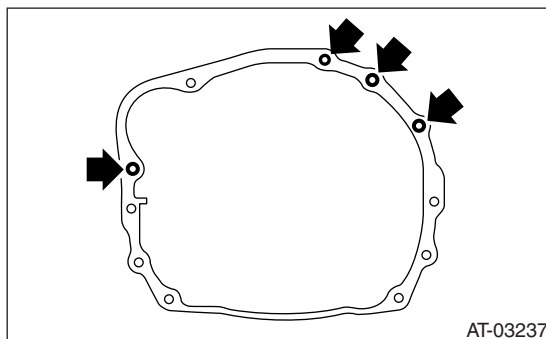

8) Remove the ST from converter case.
ST 498277200 STOPPER SET
9) Install the torque converter to drive plate.
(1) Install the bolts which hold torque converter to drive plate.
(2) Install all four bolts by rotating the crank pulley a little at a time.
(3) Install the service hole.

Tightening torque:
25 N·m (2.5 kgf-m, 18 ft-lb)

10) Install the starter. <Ref. to SC(H6DO)-6, INSTALLATION, Starter.>

Automatic Transmission Assembly

AUTOMATIC TRANSMISSION

11) Remove the ST and install the pitching stopper bracket.

Tightening torque:

40 N·m (4.1 kgf-m, 29.5 ft-lb)

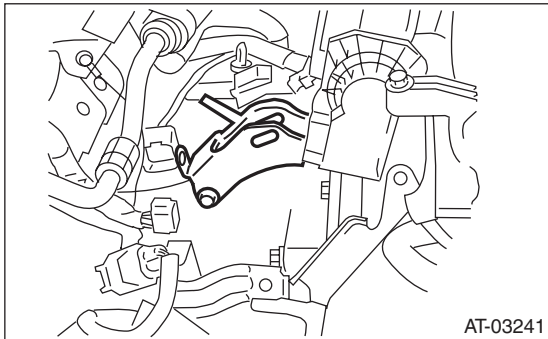

12) Attach the pitching stopper.

Tightening torque:

T1: 50 N·m (5.1 kgf-m, 36.9 ft-lb)

T2: 58 N·m (5.9 kgf-m, 42.8 ft-lb)

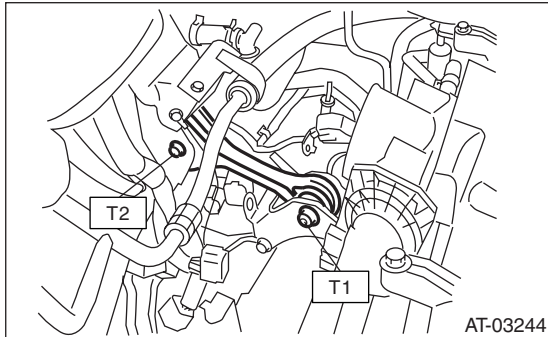

13) Lift-up the vehicle.

14) Replace the front differential side retainer oil seal.

(1) Remove the oil seal by using flat tip screw-driver etc.

(2) Install a new oil seal using ST.

ST 18675AA000 DIFFERENTIAL SIDE OIL SEAL INSTALLER

NOTE:

- Apply oil to the oil seal lips.
- Be sure to replace the differential side oil seal after the procedure of removing front drive shaft from transmission.

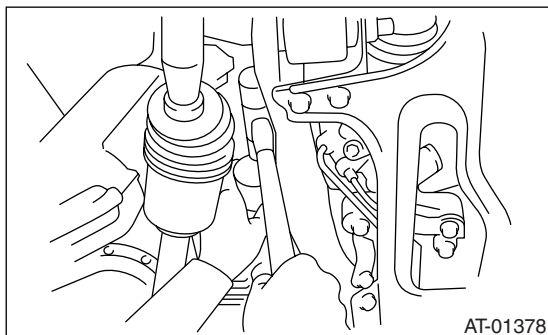

15) Apply grease to the oil seal lips.

16) Set the ST to side retainer.

ST 28399SA000 OIL SEAL PROTECTOR

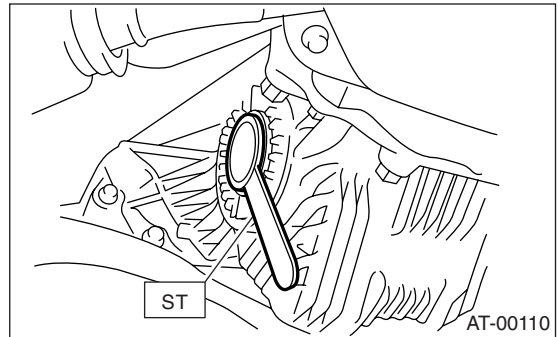

17) Install the front drive shaft into the transmission.

NOTE:

Replace the circlip of drive shaft with a new one.

18) Install the front drive shaft into transmission, remove the ST and insert the drive shaft securely.

ST 28399SA000 OIL SEAL PROTECTOR

19) Install the inlet and outlet hoses to the ATF inlet and outlet pipes.

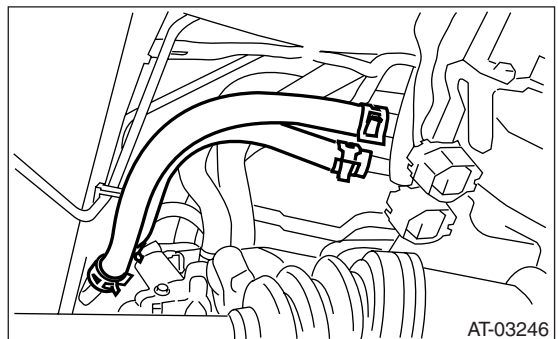

20) Insert the ball joint into housing. <Ref. to FS-15, INSTALLATION, Front Ball Joint.>

21) Install the front stabilizer clamp. <Ref. to FS-14, INSTALLATION, Front Stabilizer.>

22) Install the clutch housing cover securing bolts.

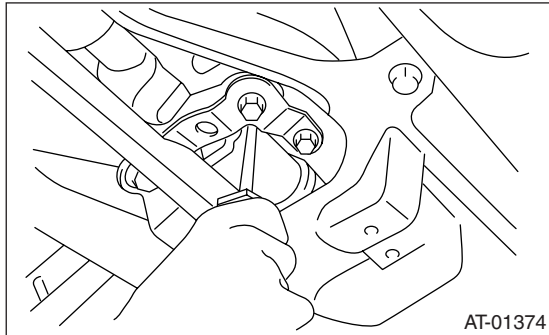
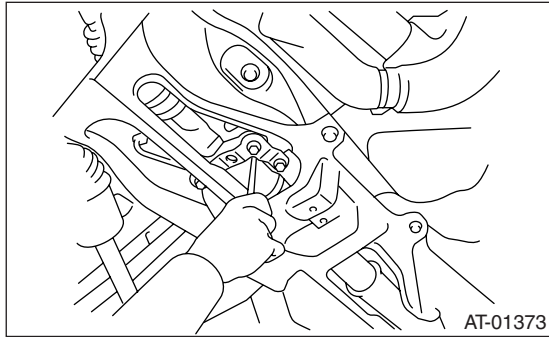

23) Install the front cross support plate. <Ref. to FS-13, INSTALLATION, Front Crossmember Support Plate.>

24) Install the propeller shaft. <Ref. to DS-11, INSTALLATION, Propeller Shaft.>

25) Install the shift select cable. <Ref. to CS-26, INSTALLATION, Select Cable.>

26) Install the turbine speed sensor 1 and harness, and then connect the connector.

Tightening torque:

7 N·m (0.7 kgf·m, 5.2 ft·lb)

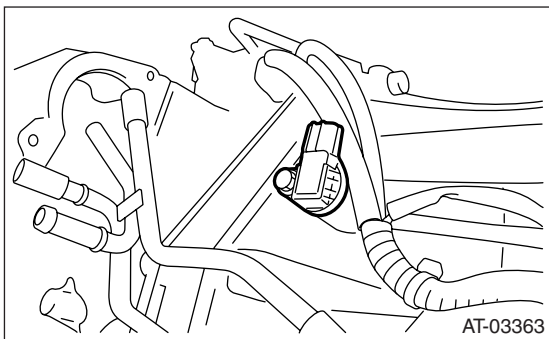

27) Install the oil charge pipe.

Tightening torque:

41 N·m (4.2 kgf·m, 30.2 ft·lb)

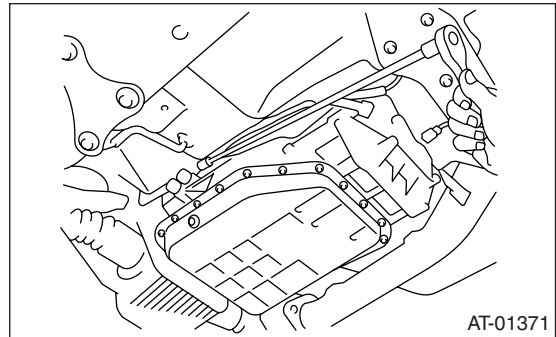

28) Install the heat shield cover.

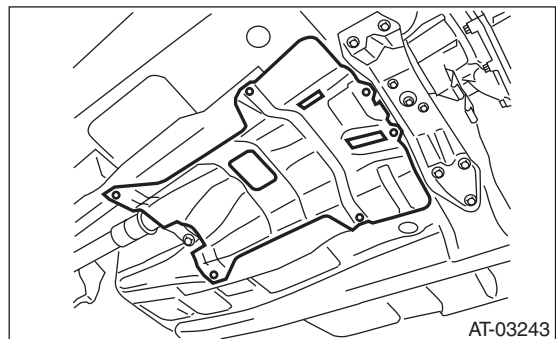

29) Install the front exhaust pipe, rear exhaust pipe and muffler. <Ref. to EX(H6DO)-5, INSTALLATION, Front Exhaust Pipe.> <Ref. to EX(H6DO)-7, INSTALLATION, Rear Exhaust Pipe.> <Ref. to EX(H6DO)-8, INSTALLATION, Muffler.>

30) Install the under cover.

31) Lower the vehicle.

32) Connect the front oxygen (A/F) sensor and transmission harness connector.

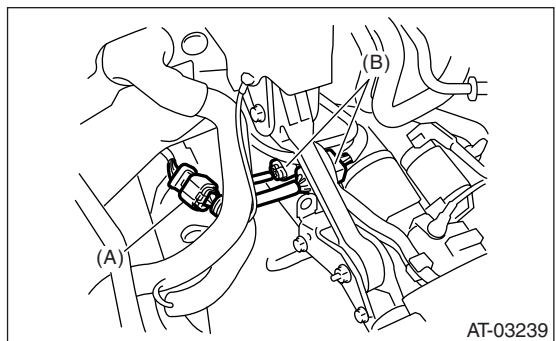

(A) Front oxygen (A/F) sensor

(B) Transmission harness connectors

33) Attach the vacuum pump and vacuum pipe & hose. <Ref. to BR-39, INSTALLATION, Brake Vacuum Pump.>

Automatic Transmission Assembly

AUTOMATIC TRANSMISSION

34) Install the engine hanger rear, and then connect the engine harness connector.

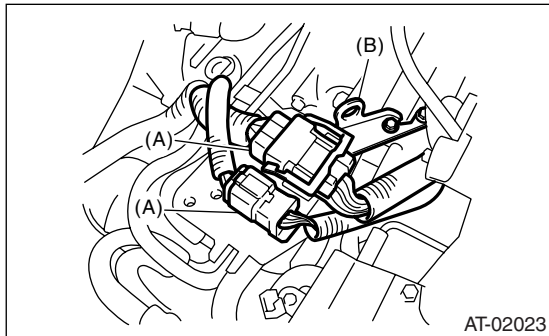

- (A) Engine harness connectors
- (B) Engine hanger rear

35) Pour ATF from the oil charge pipe. <Ref. to 5AT-26, REPLACEMENT, Automatic Transmission Fluid.>

36) Install the air breather hose. <Ref. to 5AT-60, INSTALLATION, Air Breather Hose.>

37) Install the throttle body to intake manifold.

Tightening torque:

8 N·m (0.8 kgf·m, 5.9 ft·lb)

38) Install the air intake chamber. <Ref. to IN(H6DO)-6, INSTALLATION, Air Intake Chamber.>

39) Install the collector cover.

40) Connect the ground cable to the battery.

41) Perform Clear Memory 2 operation. <Ref. to 5AT(diag)-17, CLEAR MEMORY MODE, OPERATION, Subaru Select Monitor.>

42) Perform the inspection with driving the vehicle at the end of repair work, and make sure there is no faulty as below;

- Excessive shift shock
- Oil leakage from the transmission body, etc.
- Occurrence of noise caused by interference etc.

NOTE:

If excessive shift shock is felt, execute advance operation of learning control. <Ref. to 5AT(diag)-21, PROCEDURE, Learning Control.>