

Automatic Transmission Fluid

AUTOMATIC TRANSMISSION

2. Automatic Transmission Fluid

A: INSPECTION

NOTE:

The level of ATF varies with fluid temperature. Pay attention to the ATF temperature when checking ATF level.

1) Raise the ATF temperature by driving a distance of 5 to 10 km (3 to 6 miles). Otherwise, idle the engine to raise ATF temperature to 70 — 80°C (158 — 176°F) on Subaru Select Monitor. <Ref. to 5AT(diag)-15, READ CURRENT DATA, OPERATION, Subaru Select Monitor.>

2) Park the vehicle on a level surface.

3) After selecting all positions (P, R, N, D), set the select lever in “P” range. Idle the engine for 1 or 2 minutes, and measure the ATF level.

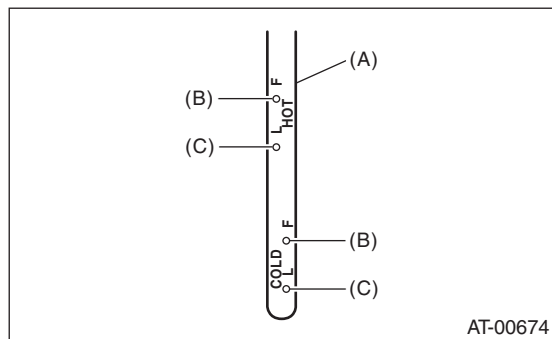

- (A) ATF level gauge
- (B) Upper level
- (C) Lower level

4) Make sure that the ATF level is between upper and lower marks of the HOT side.

5) If the ATF level is below the lower mark, add recommended ATF until the fluid level is between upper and lower marks.

CAUTION:

- Be careful not to exceed the upper level.
- When the transmission is cold, be careful not to add ATF to the upper level on HOT side. Overfilling of ATF may cause oil splashing.

6) Raise the ATF temperature by driving a distance of 5 to 10 km (3 to 6 miles). Otherwise, idle the engine to raise ATF temperature to 70 — 80°C (158 — 176°F) on Subaru Select Monitor. <Ref. to 5AT(diag)-15, READ CURRENT DATA, OPERATION, Subaru Select Monitor.>

7) Check the ATF for leaks.

Visually check for leaks in the transmission. If there are leaks, replace the gasket, oil seal, plug or other parts.

B: REPLACEMENT

- 1) Lift-up the vehicle.
- 2) Remove the ATF drain plug to drain ATF.

CAUTION:

Directly after the vehicle has been running or the engine has been long idle running, the ATF is hot. Be careful not to burn yourself.

3) Check the condition of ATF.

<Ref. to 5AT-27, CONDITION CHECK, Automatic Transmission Fluid.>

4) Tighten the ATF drain plug.

NOTE:

Use a new gasket.

Tightening torque:

20 N·m (2.0 kgf·m, 14.8 ft·lb)

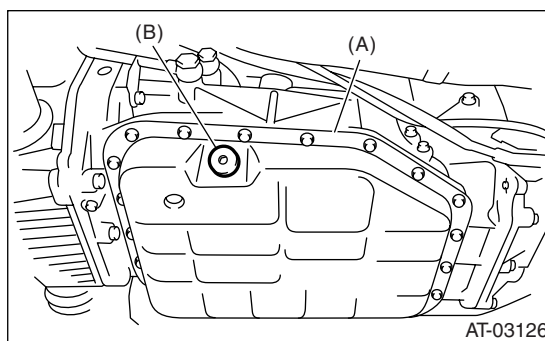

- (A) Oil pan
- (B) ATF drain plug

5) Lower the vehicle.

6) Pour ATF from the oil charge pipe.

Specified fluid:

SUBARU ATF (Part No. K0140Y0700)

Recommended fluid:

IDEMITSU ATF HP

CASTROL TRANSMAX J

PENNZOIL QUAKERSTATE • PENNZOIL ATF-J

NOTE:

Use of the recommended fluid is permitted only in regions where the specified fluid is not available.

Capacity:

Fill with the same amount of ATF as drained.

Capacity when transmission is overhauled:

9.6 — 10.0 ℓ (10.1 — 10.6 US qt, 8.4 — 8.8 Imp qt)

7) Check the level and leaks of ATF.

<Ref. to 5AT-26, INSPECTION, Automatic Transmission Fluid.>

C: CONDITION CHECK

NOTE:

When replacing ATF, check the inside condition of transmission body by inspecting the drained ATF.

Fluid condition	Trouble and possible cause	Corrective action
Large amount of metallic pieces are found.	Internal metal parts of transmission body are excessively worn.	Replace ATF and check if AT operates correctly.
Is thick and is a varnish-form fluid.	Clutch etc. is burned.	Replace ATF and check the AT body or vehicle for faulty.
Clouded fluid or bubbles are found in fluid.	Water is mixed.	Replace ATF and check the water entering point.