

28.Center Differential Carrier

A: REMOVAL

- 1) Remove the transmission assembly from vehicle body. <Ref. to 5AT-34, REMOVAL, Automatic Transmission Assembly.>
- 2) Remove the rear wheel speed sensor, and separate the extension case from transmission case. <Ref. to 5AT-63, REMOVAL, Extension Case.>
- 3) Extract the rear drive shaft. <Ref. to 5AT-67, REMOVAL, Rear Drive Shaft.>
- 4) Pull out the center differential carrier assembly.

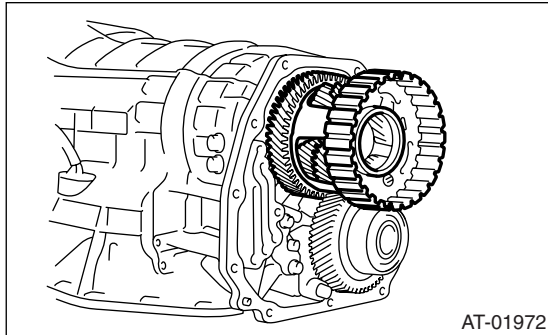

- 5) Pull out the shim(s) from transmission case.

B: INSTALLATION

- 1) Install the center differential assembly with the shim(s).

NOTE:

Press-fit it to the bottom of bearing shoulder completely.

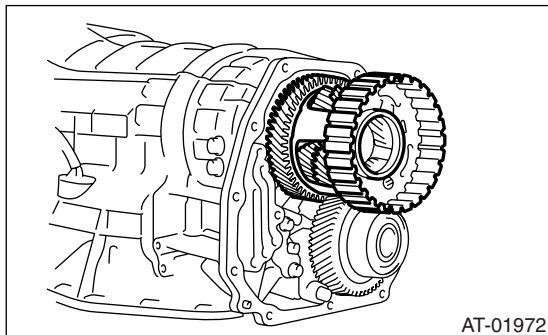

- 2) Insert the rear driveshaft assembly. <Ref. to 5AT-67, INSTALLATION, Rear Drive Shaft.>
- 3) Join the transmission case and the extension case, and then install the rear vehicle speed sensor. <Ref. to 5AT-63, INSTALLATION, Extension Case.>
- 4) Install the transmission assembly to the vehicle. <Ref. to 5AT-37, INSTALLATION, Automatic Transmission Assembly.>

C: DISASSEMBLY

- 1) Remove the seal ring.

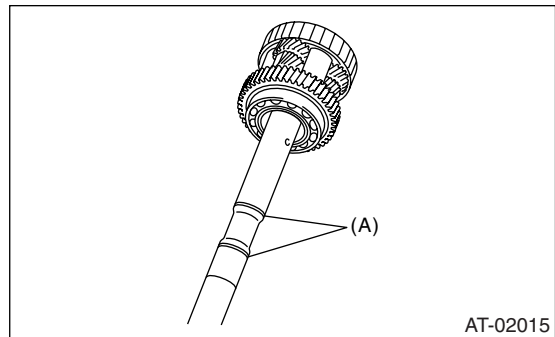

(A) Seal ring

- 2) Remove the snap ring, and pull out the shaft from center differential assembly.

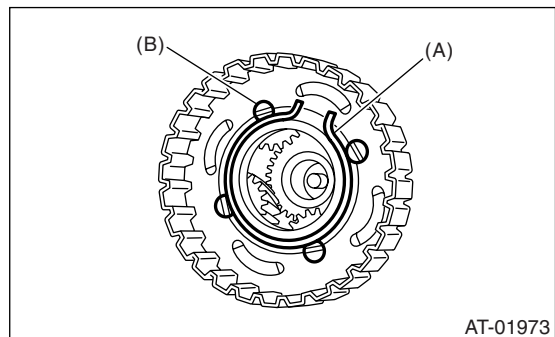

(A) Snap ring

(B) Shaft

- 3) Remove the thrust washers, pinion gears and washers from center differential assembly.

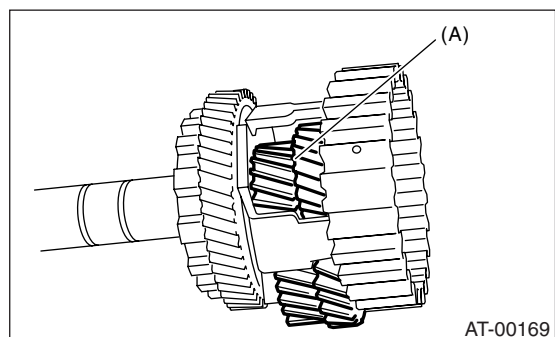

(A) Pinion gear

- 4) Pull out the intermediate shaft and thrust bearing.

Center Differential Carrier

AUTOMATIC TRANSMISSION

5) Extract the ball bearing with ST1 and ST2.

ST1 18654AA000 INSTALLER

ST2 18767AA000 REMOVER

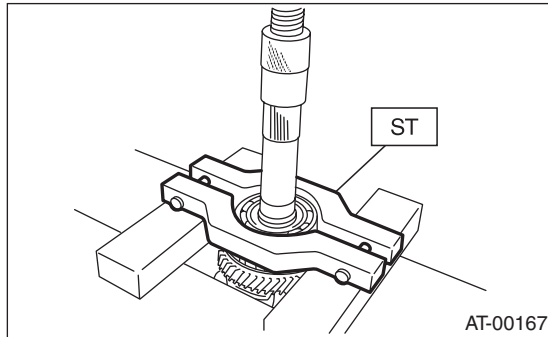

D: ASSEMBLY

- 1) Install the thrust washer onto intermediate shaft.
- 2) Install the thrust bearing onto intermediate shaft.
- 3) Install the pinion gears and washers.
- 4) Insert the shaft into the center differential assembly.
- 5) Install the snap ring.
- 6) Using a press, install a new ball bearing into the center differential assembly.

ST 498077000 REMOVER

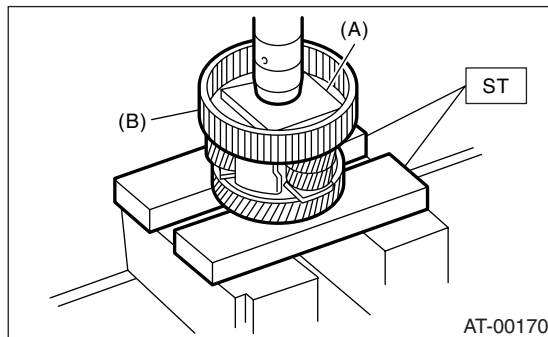

(A) Plate

(B) Center differential carrier

7) Apply vaseline onto the seal ring outer surface and shaft grooves.

8) Install a new seal ring.

E: INSPECTION

- Check each parts for holes, damages or other foreign matters.
- Inspect the extension end play, and adjust it to within the standard value. <Ref. to 5AT-65, ADJUSTMENT, Transfer Clutch.>