

17. Control Valve Body

A: REMOVAL

- 1) Set the vehicle on a lift.
- 2) Disconnect the ground cable from battery.
- 3) Lift-up the vehicle.
- 4) Clean the transmission exterior.
- 5) Remove the ATF drain plug to drain ATF.

CAUTION:

Immediately after the vehicle has been running or after idling for a long time, the ATF will be hot. Be careful not to burn yourself.

- 6) Tighten the ATF drain plug.

NOTE:

Use a new gasket.

Tightening torque:

20 N·m (2.0 kgf·m, 14.8 ft·lb)

- 7) Remove the oil pan.

CAUTION:

Be sure to prevent the entering of dust and other foreign matters into oil pan.

- 8) Remove the magnet.

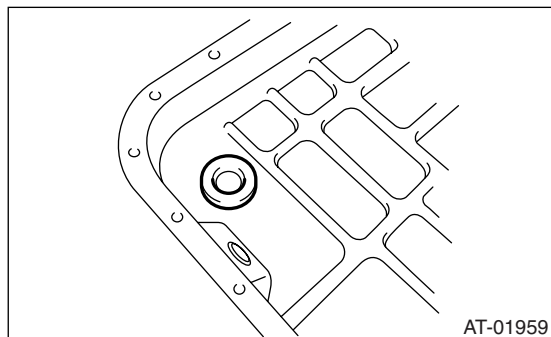

- 9) Clean the magnet.
- 10) Completely remove the remaining liquid gasket on the transmission case and oil pan.
- 11) Disconnect the control valve connector and front vehicle speed sensor connector.

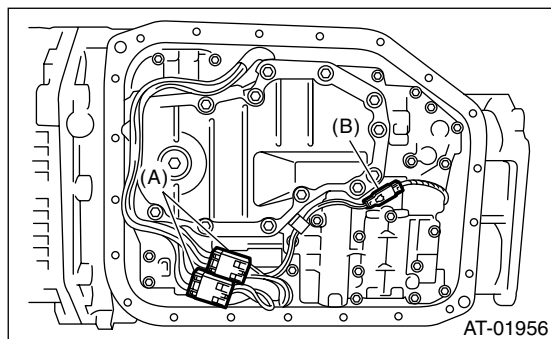

- (A) Control valve connector
- (B) Front vehicle speed sensor connector

- 12) Remove the control valve body.

NOTE:

The control valve body is replaced as an assembly only, because it is a non-disassembly part.

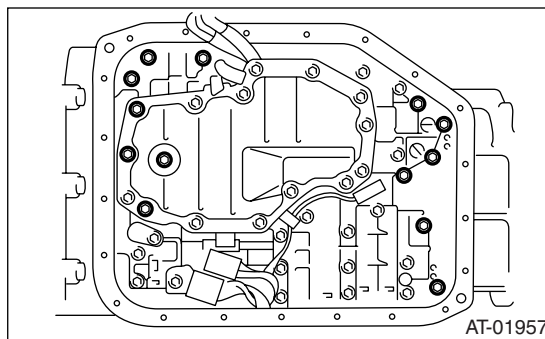

B: INSTALLATION

- 1) Check the control valve body for dust and other foreign matter.
- 2) Install the control valve body to transmission by equally tightening the bolts.

Tightening torque:

8 N·m (0.8 kgf·m, 5.8 ft·lb)

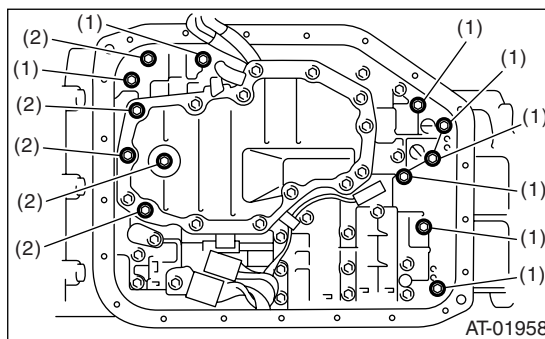

- (1) 58 mm (2.28 in)
- (2) 65 mm (2.56 in)

- 3) Connect the control valve connector.

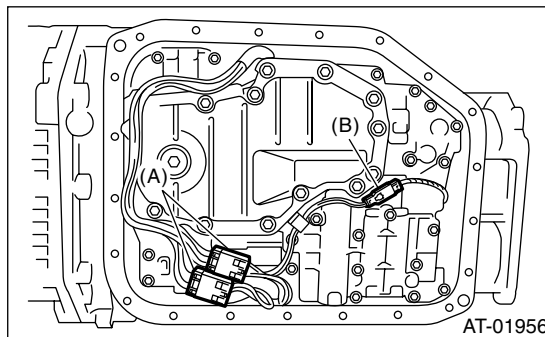

- (A) Control valve connector
- (B) Front vehicle speed sensor connector

Control Valve Body

AUTOMATIC TRANSMISSION

- 4) Attach the magnet at the specified position of the oil pan.

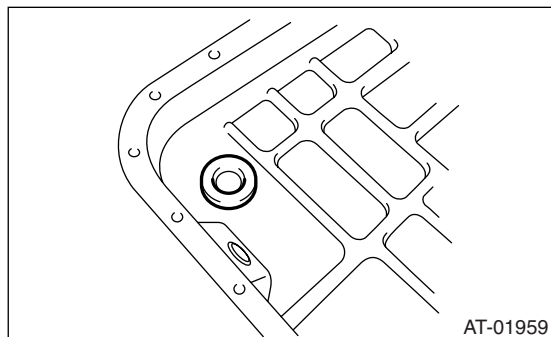

- 5) Apply liquid gasket to the oil pan.

Liquid gasket:

THREE BOND 1217B (Part No. K0877YA020)

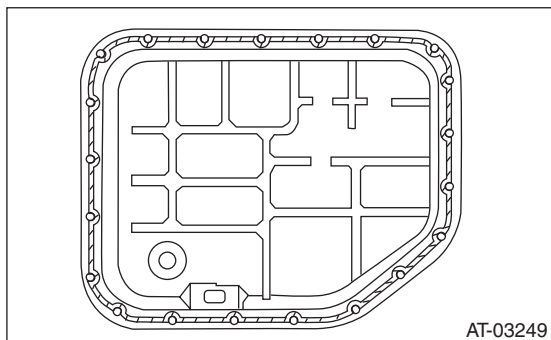

- 6) Install the oil pan by equally tightening the bolts.

Tightening torque:

5 N·m (0.5 kgf·m, 3.7 ft·lb)

- 7) Pour ATF through the oil charge pipe.

Specified and recommended fluid:

<Ref. to 5AT-3, RECOMMENDED GEAR OIL, SPECIFICATION, General Description.>

Capacity:

Fill with the same amount of ATF as drained.

- 8) Check the ATF level.

<Ref. to 5AT-26, Automatic Transmission Fluid.>

- 9) Perform Clear Memory 2 operation. <Ref. to 5AT(diag)-17, CLEAR MEMORY MODE, OPERATION, Subaru Select Monitor.>

- 10) Perform the inspection with driving the vehicle at the end of repair work, and make sure there is no faulty as below;

- Excessive shift shock
- Oil leakage from the transmission body, etc.
- Occurrence of noise caused by interference etc.

NOTE:

If excessive shift shock is felt, execute advance operation of learning control. <Ref. to 5AT(diag)-21, PROCEDURE, Learning Control.>

C: INSPECTION

Check each parts for holes, damages or other foreign matters.