

30. Converter Case

A: REMOVAL

- 1) Remove the transmission assembly from vehicle body. <Ref. to 5AT-34, REMOVAL, Automatic Transmission Assembly.>
- 2) Remove the torque converter assembly. <Ref. to 5AT-62, REMOVAL, Torque Converter Assembly.>
- 3) Remove the transmission harness connector from stay.
- 4) Remove the turbine speed sensor 1. <Ref. to 5AT-52, REMOVAL, Turbine Speed Sensor 1.>
- 5) Remove the oil charge pipe. <Ref. to 5AT-61, REMOVAL, Oil Charge Pipe.>
- 6) Remove the ATF filter inlet and outlet pipes. <Ref. to 5AT-57, REMOVAL, ATF Cooler Pipe & Hose.>
- 7) Remove the converter case attachment bolts.
- 8) Lay along the transmission body, and then remove the oil pan.
- 9) Remove the three converter case mounting bolts (TORX®).

ST 18676AA020 TORX® WRENCH

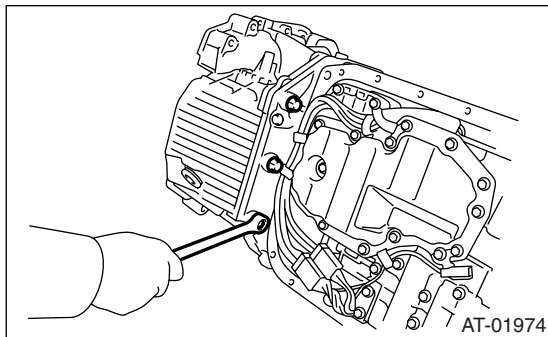

- 10) Separate the converter case by lightly tapping with plastic hammer.
- 11) Remove the differential assembly. <Ref. to 5AT-86, REMOVAL, Front Differential Assembly.>
- 12) Remove the oil seal from converter case.

B: INSTALLATION

- 1) Check the appearance of each component and clean them.
- 2) Press-fit the oil seal to converter case using ST. ST 499587100 OIL SEAL INSTALLER

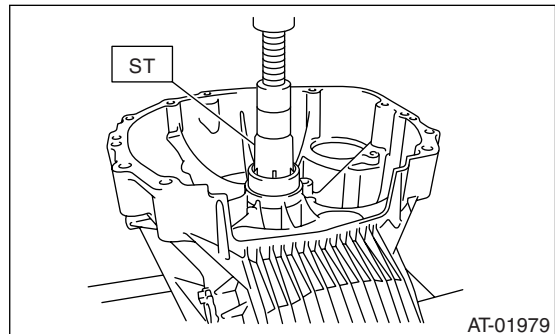

- 3) Install the differential assembly to the case. <Ref. to 5AT-86, INSTALLATION, Front Differential Assembly.>
- 4) Install the right and left side retainers. <Ref. to 5AT-89, ADJUSTMENT, Front Differential Assembly.>
- 5) Apply proper amount of liquid gasket to the entire matching surface of converter case.

Liquid gasket:

THREE BOND 1215 (Part No. 004403007)

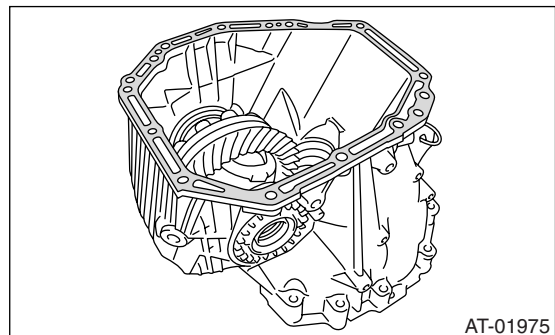

- 6) Install the converter case assembly without damaging bushing and oil seal.

Tightening torque:

41 N·m (4.2 kgf-m, 30.4 ft-lb)

Converter Case

AUTOMATIC TRANSMISSION

7) Install the three converter case mounting bolts (TORX®).

ST 18676AA020 TORX® WRENCH

Tightening torque:

41 N·m (4.2 kgf·m, 30.4 ft·lb)

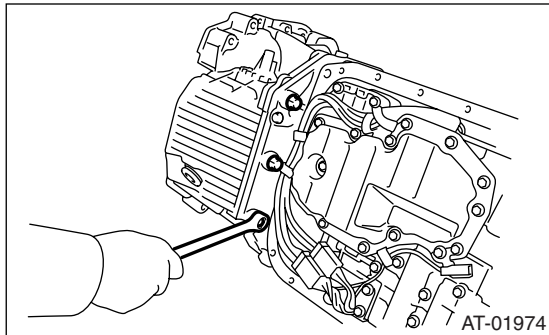

8) Apply proper amount of liquid gasket to the entire oil pan mating surface, and then install it.

Liquid gasket:

THREE BOND 1217B (Part No. K0877YA020)

Tightening torque:

5 N·m (0.5 kgf·m, 3.7 ft·lb)

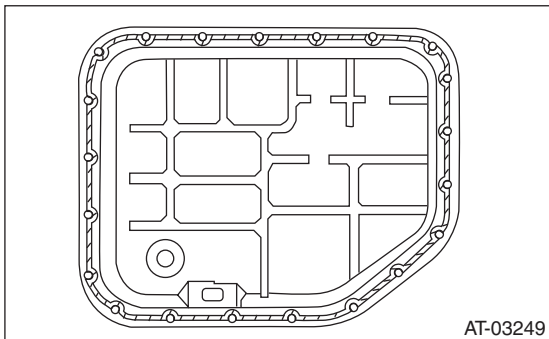

9) Install the transmission harness connector to the stay.

10) Install the air breather hose. <Ref. to 5AT-60, INSTALLATION, Air Breather Hose.>

11) Install the ATF filter pipe. <Ref. to 5AT-58, INSTALLATION, ATF Cooler Pipe & Hose.>

12) Install the oil charge pipe with O-ring. <Ref. to 5AT-61, INSTALLATION, Oil Charge Pipe.>

13) Install the torque converter assembly. <Ref. to 5AT-62, INSTALLATION, Torque Converter Assembly.>

14) Install the transmission assembly to the vehicle. <Ref. to 5AT-37, INSTALLATION, Automatic Transmission Assembly.>

C: INSPECTION

Measure the backlash, and then adjust it to be within standard values. <Ref. to 5AT-83, ADJUSTMENT, Drive Pinion Shaft Assembly.>