

## 32. Drive Pinion Shaft Assembly

### A: REMOVAL

- 1) Remove the transmission assembly from vehicle body. <Ref. to 5AT-34, REMOVAL, Automatic Transmission Assembly.>
- 2) Pull out the torque converter assembly. <Ref. to 5AT-62, REMOVAL, Torque Converter Assembly.>
- 3) Remove the transmission harness connector from stay.
- 4) Disconnect the air breather hose. <Ref. to 5AT-60, REMOVAL, Air Breather Hose.>
- 5) Remove the oil charge pipe. <Ref. to 5AT-61, REMOVAL, Oil Charge Pipe.>
- 6) Remove the ATF filter inlet and outlet pipes. <Ref. to 5AT-57, REMOVAL, ATF Cooler Pipe & Hose.>
- 7) Separate the converter case and transmission case. <Ref. to 5AT-75, REMOVAL, Converter Case.>
- 8) Remove the drive pinion shaft mounting bolts, and then remove the drive pinion shaft assembly from oil pump cover.

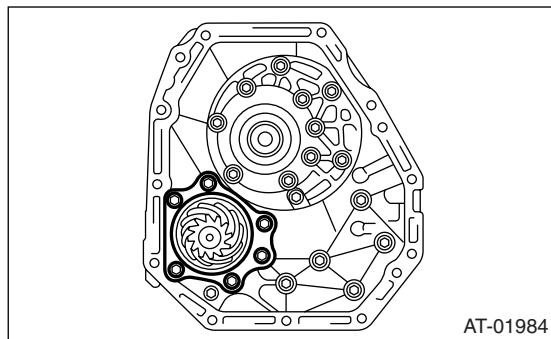

- 9) Remove the oil pump cover from AT main case. <Ref. to 5AT-77, Oil Pump Cover.>

### B: INSTALLATION

- 1) Assemble the drive pinion assembly to oil pump cover.

#### NOTE:

Be careful not to bend the shim.

#### Tightening torque:

**70 N·m (7.1 kgf·m, 51.6 ft·lb)**

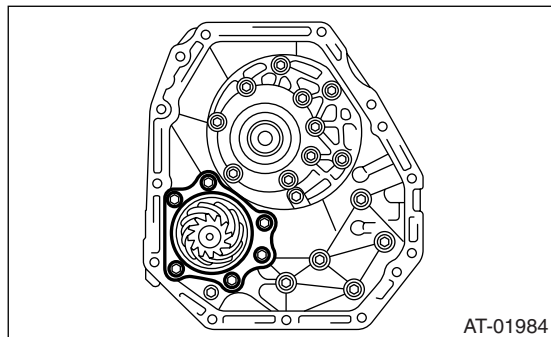

- 2) Adjust the tooth contact between drive pinion shaft assembly and the front differential side gear. <Ref. to 5AT-83, ADJUSTMENT, Drive Pinion Shaft Assembly.>
- 3) Join the converter case with the transmission case. <Ref. to 5AT-75, INSTALLATION, Converter Case.>
- 4) Install the transmission harness connector to the stay.
- 5) Install the ATF filter pipe. <Ref. to 5AT-58, INSTALLATION, ATF Cooler Pipe & Hose.>
- 6) Install the oil charge pipe with O-ring.
- 7) Install the torque converter assembly. <Ref. to 5AT-62, INSTALLATION, Torque Converter Assembly.>
- 8) Install the transmission assembly to the vehicle. <Ref. to 5AT-37, INSTALLATION, Automatic Transmission Assembly.>

### C: DISASSEMBLY

- 1) Remove the crimped part of the lock nut, and then remove the lock nut while holding the rear spline part of the shaft using ST1 and ST2. Pull out the drive pinion collar.

- ST1 18667AA010 HOLDER  
 ST2 499787700 WRENCH  
 ST3 499787500 ADAPTER

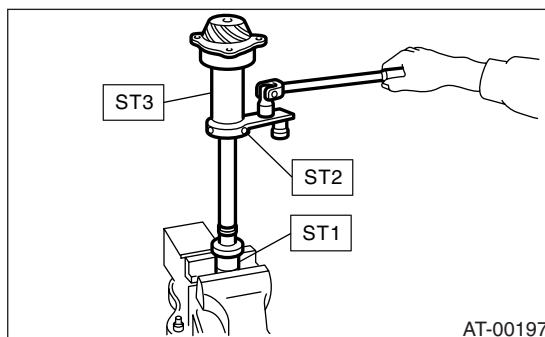

- 2) Remove the O-ring.
- 3) Separate the roller bearing and outer race from shaft using a press.

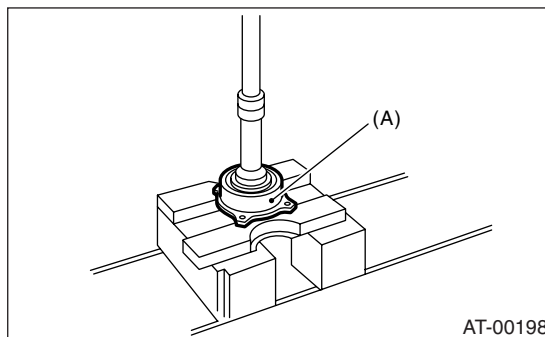

(A) Outer race

# Drive Pinion Shaft Assembly

## AUTOMATIC TRANSMISSION

4) Separate the front roller bearing from shaft using a press and ST.

ST 498517000 REPLACER

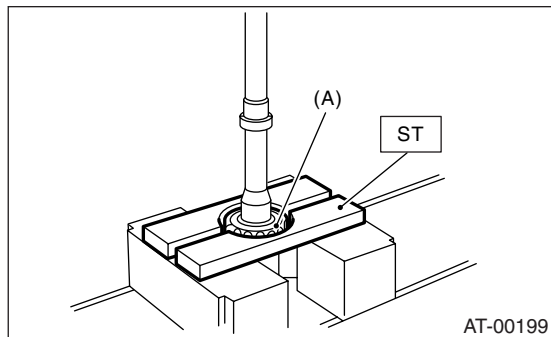

(A) Front roller bearing

## D: ASSEMBLY

1) Measure the dimension "A" of the drive pinion shaft.

ST 398643600 GAUGE

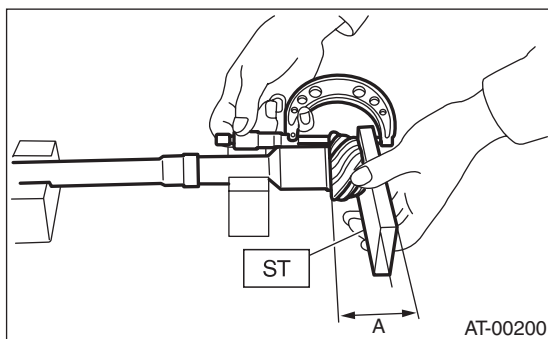

2) Using a press, press-fit the new roller bearing into the specified position.

### NOTE:

If excessive force is applied to roller bearing, the roller bearing will not turn easily.

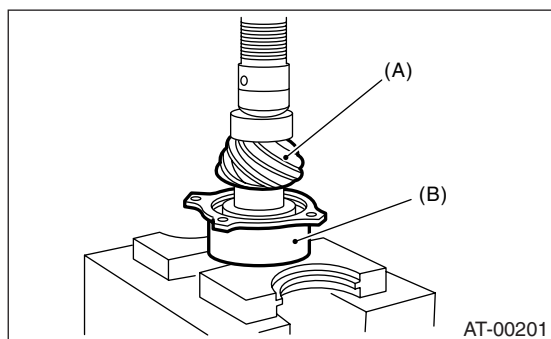

(A) Drive pinion shaft

(B) Roller bearing

3) After fitting a new O-ring to the shaft, attach the drive pinion collar to the shaft.

4) Tighten the new lock nuts using ST1, ST2 and ST3.

Using the following equation, calculate the tightening torque.

$$T2 = L2 / (L1 + L2) \times T1$$

T1: 116 N·m (11.8 kgf·m, 85.3 ft·lb)

[Required torque setting]

T2: Tightening torque

L1: ST2 length 0.072 m (2.83 in)

L2: Torque wrench length

Example:

Torque wrench length m (in)	Tightening torque N·m (kgf·m, ft·lb)
0.4 (15.75)	98 (10.0, 72)
0.45 (17.72)	100 (10.2, 73.8)
0.5 (19.69)	101 (10.3, 74.5)
0.55 (21.65)	102 (10.4, 75)

ST1 18667AA010 HOLDER

ST2 499787700 WRENCH

ST3 499787500 ADAPTER

### NOTE:

Attach ST2 to torque wrench as straight as possible.

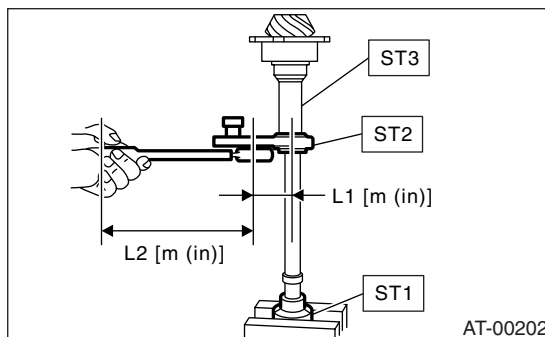

5) Measure the starting torque of the bearing. Make sure the starting torque is within the specified range. If the torque is not within specified range, replace the roller bearing.

### Starting torque:

**7.6 — 38.1 N (0.776 — 3.88 kgf, 1.7 — 8.6 lb)**

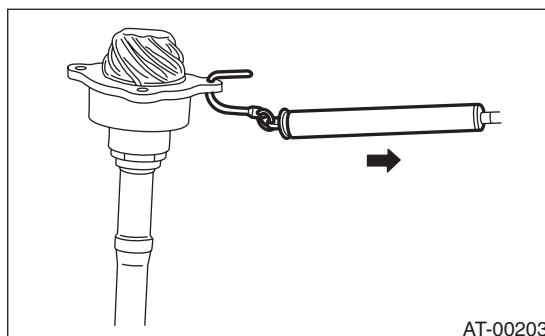

6) Crimp the locknut in 2 locations.

7) Measure dimension "B" of the drive pinion shaft  
ST 398643600 GAUGE

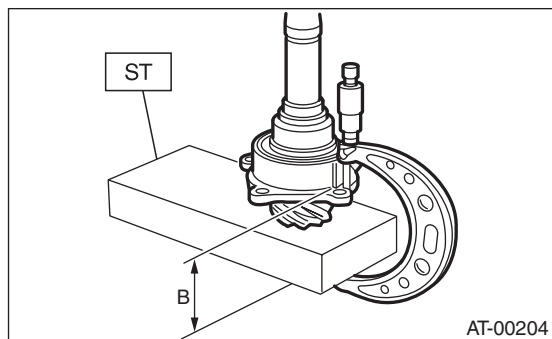

8) Calculate the thickness "t" (mm) of the drive pinion shim.

$$t = 6.5 \pm 0.0625 - (B - A)$$

9) Select three or less shims from following table.

Drive pinion shim	
Part No.	Thickness mm (in)
31451AA180	0.150 (0.0059)
31451AA190	0.175 (0.0069)
31451AA200	0.200 (0.0079)
31451AA210	0.225 (0.0089)
31451AA220	0.250 (0.0098)
31451AA230	0.275 (0.0108)

## E: INSPECTION

- Make sure that all component parts are free of scratches, holes and other faults.
- Adjust the tooth alignment. <Ref. to 5AT-83, ADJUSTMENT, Drive Pinion Shaft Assembly.>

## F: ADJUSTMENT

- 1) Remove the liquid gasket from the mating surface completely.
- 2) Install the converter case to oil pump cover, and secure them with tightening four bolts evenly.

### NOTE:

Use an old gasket or aluminum washer to prevent damaging the mating surface of the housing.

### Tightening torque:

**41 N·m (4.2 kgf·m, 30.4 ft·lb)**

3) Rotate the drive pinion a few times using ST1 and ST2.

ST1 18667AA010 HOLDER  
ST2 499787700 WRENCH

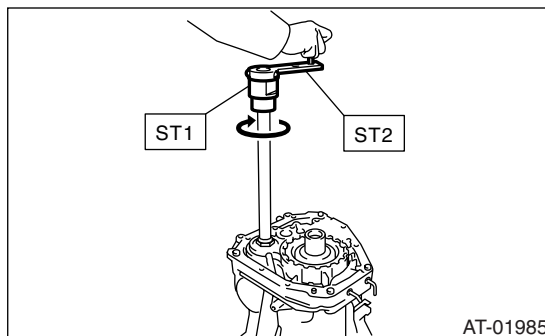

4) Adjust the drive pinion and hypoid driven gear backlash. <Ref. to 5AT-89, ADJUSTMENT, Front Differential Assembly.>

5) Apply red lead evenly to the surfaces of three or four teeth on hypoid driven gear. Rotate the drive pinion in the leftward and rightward for several times. Remove the oil pump cover, and check the tooth contact pattern.

If the teeth contact is inappropriate, adjust the backlash or thickness of the shim. <Ref. to 5AT-89, ADJUSTMENT, Front Differential Assembly.>

- Correct tooth contact

**Check item: Tooth contact surface is slightly shifted toward the toe side under a no-load condition. (When driving, it moves towards the heel side.)**

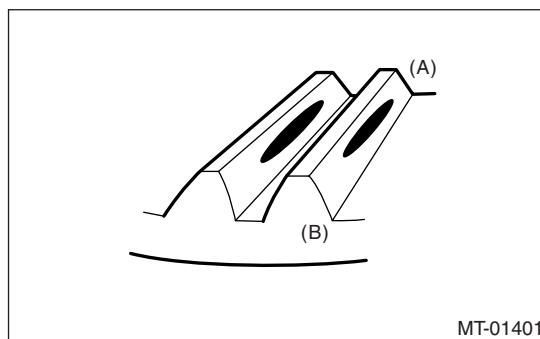

- (A) Toe side
- (B) Heel side

# Drive Pinion Shaft Assembly

## AUTOMATIC TRANSMISSION

- Face contact

**Inspection item: Backlash is too large.**

Contact pattern

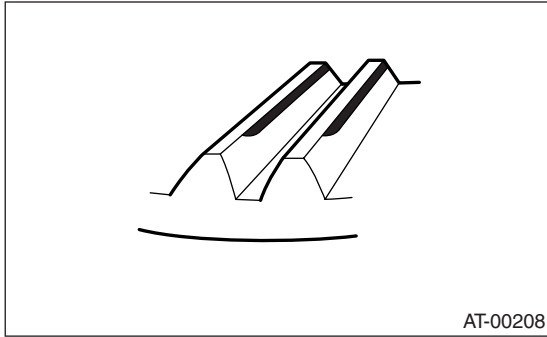

Corrective action: Increase thickness of drive pinion height adjusting washer in order to bring drive pinion close to driven gear.

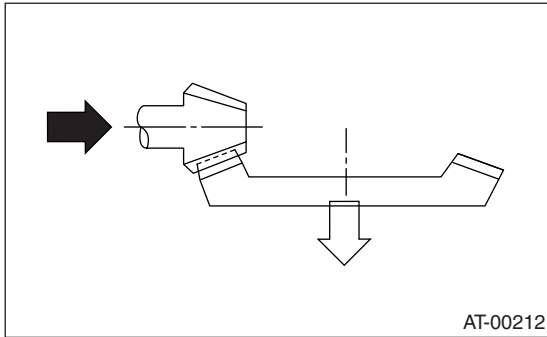

- Flank contact

**Inspection item: Backlash is too small.**

Contact pattern

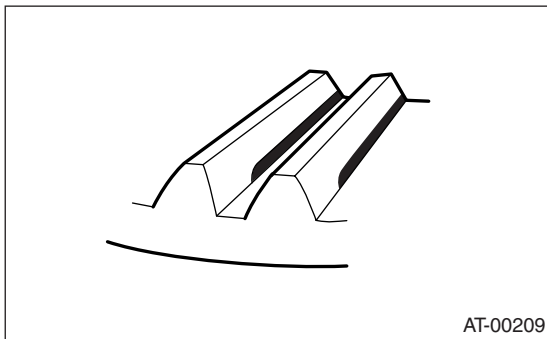

Adjustment: Reduce the thickness of pinion height adjusting washer according to the procedure for bringing drive pinion away from driven gear.

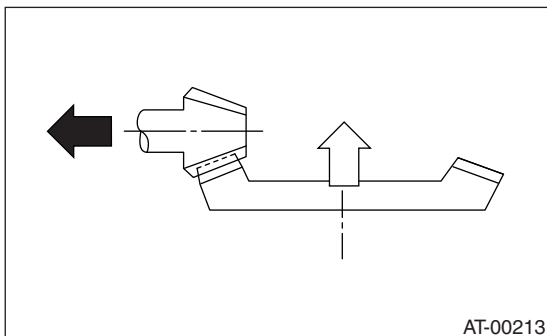

- Toe contact (inside contact)

**Inspection item: Contact area is too small.**

Contact pattern

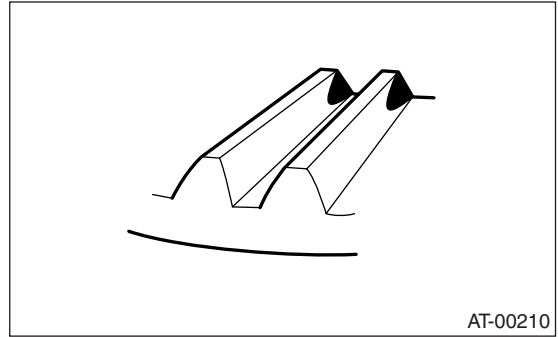

Adjustment: Reduce the thickness of pinion height adjusting washer according to the procedure for bringing drive pinion away from driven gear side.

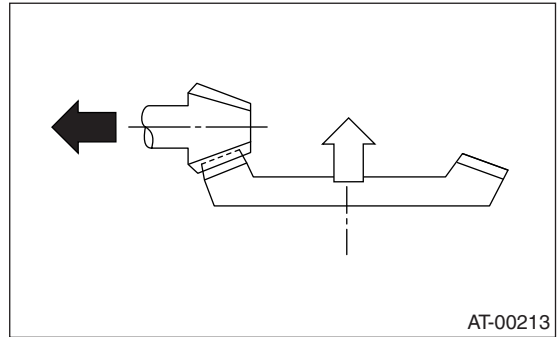

- Heel contact (outside end contact)

**Inspection item: Contact area is too small.**

Contact pattern

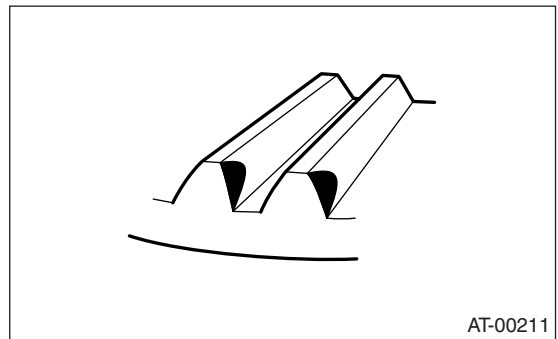

Corrective action: Increase thickness of drive pinion height adjusting washer in order to bring drive pinion close to driven gear.

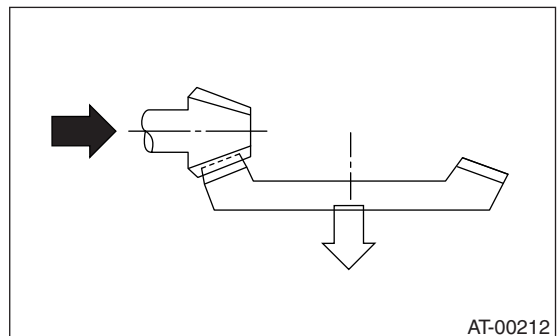

6) If tooth contact is correct, mark the retainer position and loosen it. After fitting a new O-ring and oil seal, screw in the retainer to the marked position. Tighten the lock plate with specified torque.

**Tightening torque:**

**25 N·m (2.5 kgf·m, 18 ft·lb)**

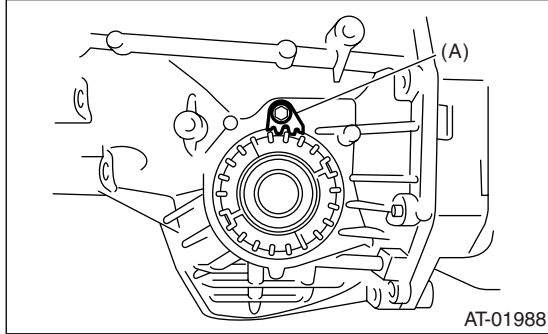

(A) Lock plate