

Front Differential Assembly

AUTOMATIC TRANSMISSION

33. Front Differential Assembly

A: REMOVAL

- 1) Remove the transmission assembly from vehicle body. <Ref. to 5AT-34, REMOVAL, Automatic Transmission Assembly.>
- 2) Pull out the torque converter assembly. <Ref. to 5AT-62, REMOVAL, Torque Converter Assembly.>
- 3) Remove the transmission harness connector from stay.
- 4) Remove the oil charge pipe. <Ref. to 5AT-61, REMOVAL, Oil Charge Pipe.>
- 5) Remove the ATF filter inlet and outlet pipes. <Ref. to 5AT-57, REMOVAL, ATF Cooler Pipe & Hose.>
- 6) Separate the converter case from the transmission case. <Ref. to 5AT-75, REMOVAL, Converter Case.>
- 7) Remove the differential side retainers using ST.

NOTE:

Hold the differential case assembly by hand to avoid damaging the retainer mounting hole of the converter case.

ST 18630AA010 WRENCH COMPL RETAINER

- 8) Remove the differential assembly while being careful not to damage the attachment part of retainer.

B: INSTALLATION

- 1) When installing the differential assembly to case, be careful not to damage the inside of case (particularly, the differential side retainer mating surface).

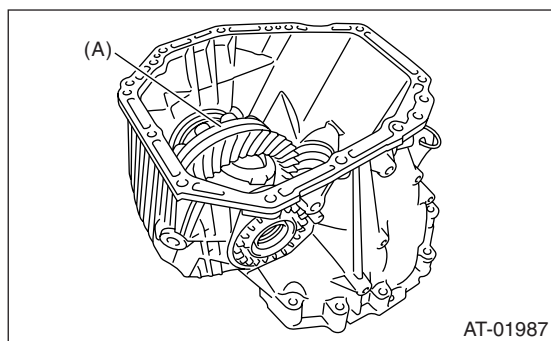

(A) Differential ASSY

- 2) Install the O-ring to left and right side retainer.
- 3) Using the ST, install the side retainer. <Ref. to 5AT-86, REMOVAL, Front Differential Assembly.>
ST 18630AA010 WRENCH COMPL RETAINER

- 4) Adjust the backlash of the front differential. <Ref. to 5AT-89, ADJUSTMENT, Front Differential Assembly.>

- 5) Install the lock plate.

Tightening torque:

25 N·m (2.5 kgf-m, 18 ft-lb)

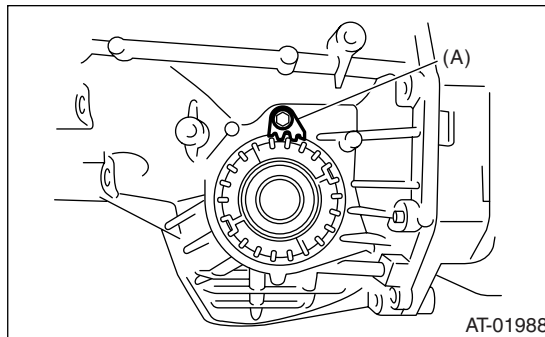

(A) Lock plate

- 6) Install the converter case to the transmission case. <Ref. to 5AT-75, INSTALLATION, Converter Case.>
- 7) Install the transmission harness connector to the stay.
- 8) Install the ATF filter pipe. <Ref. to 5AT-58, INSTALLATION, ATF Cooler Pipe & Hose.>
- 9) Install the oil charge pipe together with an O-ring. <Ref. to 5AT-61, INSTALLATION, Oil Charge Pipe.>
- 10) Install the torque converter assembly. <Ref. to 5AT-62, INSTALLATION, Torque Converter Assembly.>
- 11) Install the transmission assembly to the vehicle. <Ref. to 5AT-37, INSTALLATION, Automatic Transmission Assembly.>

C: DISASSEMBLY

1. DIFFERENTIAL CASE ASSEMBLY

- 1) Remove the taper roller bearing using the ST and a press.

ST 498077000 REMOVER

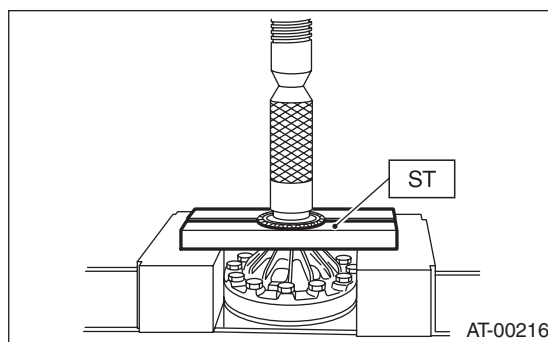

Front Differential Assembly

AUTOMATIC TRANSMISSION

2) Secure the case in a vise, remove the hypoid driven gear tightening bolts, and then separate the hypoid driven gear into case (RH) and case (LH).

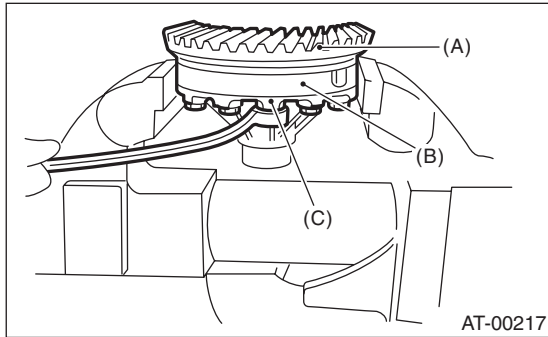

- (A) Hypoid driven gear
- (B) Differential case (RH)
- (C) Differential case (LH)

3) Pull out the straight pin and shaft, and then remove the differential bevel gear, washer and differential bevel pinion.

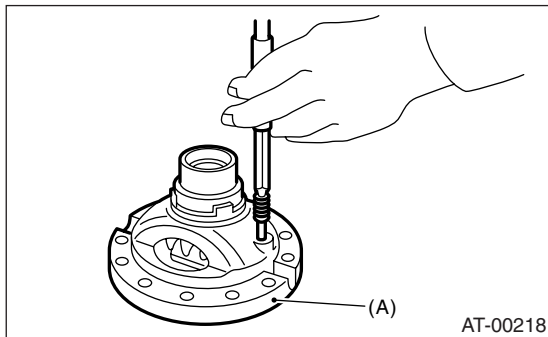

- (A) Differential case (RH)

2. SIDE RETAINER

NOTE:

After adjusting the drive pinion backlash and tooth contact, remove and install the oil seal and O-ring.

1) Remove the O-ring.

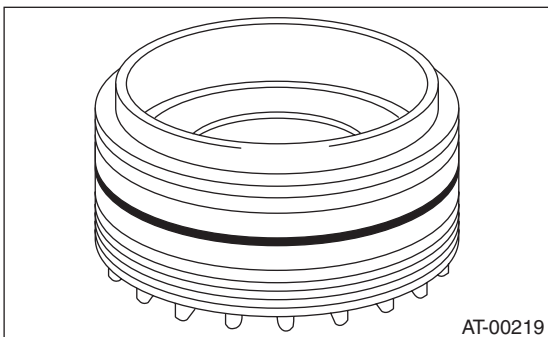

AT-00219

2) Remove the oil seal.

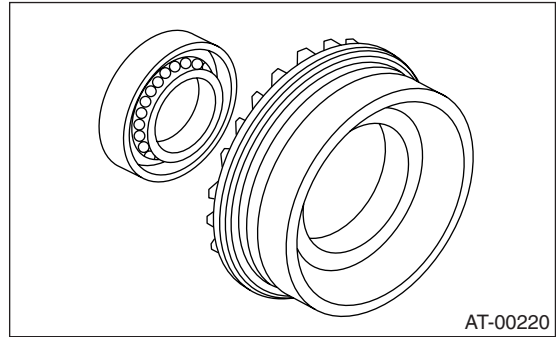

AT-00220

3) Remove the split pin, and then remove the claw.
ST 398527700 PULLER

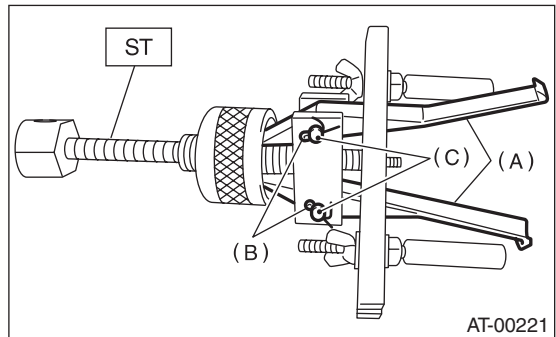

AT-00221

- (A) Claw
- (B) Split pin
- (C) Pin

4) Attach two claws to the outer race, and set the ST to side retainer.

ST 398527700 PULLER

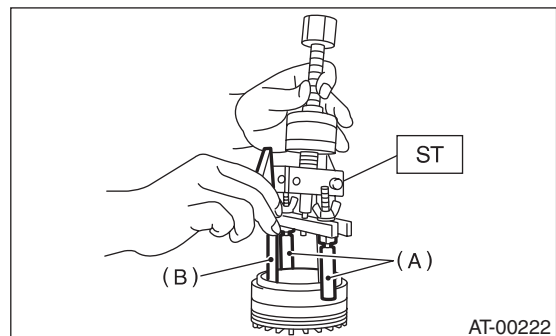

AT-00222

- (A) Shaft
- (B) Claw

5) Restore the removed claws to original position, and install the pin and split pin.

Front Differential Assembly

AUTOMATIC TRANSMISSION

6) Hold the shaft of ST to avoid removing from side retainer, and then remove the bearing outer race.
ST 398527700 PULLER

NOTE:

Replace the bearing inner and outer races as a single unit.

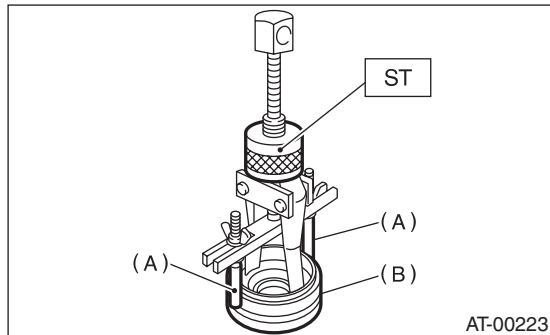

- (A) Shaft
- (B) Side retainer

D: ASSEMBLY

1. DIFFERENTIAL CASE ASSEMBLY

- 1) Install the washer, differential bevel gear and differential bevel pinion in the differential case (RH). Insert the pinion shaft.
- 2) Attach the straight pin in the reverse direction.

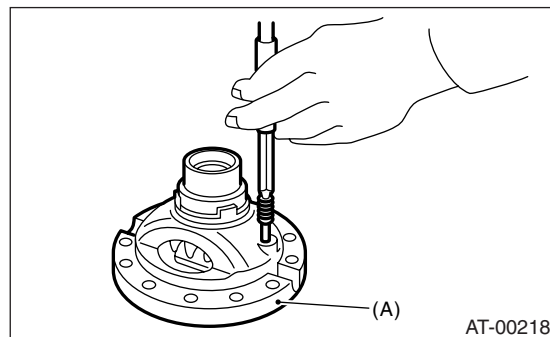

- (A) Differential case (RH)

- 3) Install the washer and differential bevel gear to differential case (LH). Put the differential case (RH) on the case, and then assemble the two cases.
- 4) Install the hypoid driven gear and secure by tightening the bolt.

Tightening torque:

70 N·m (7.1 kgf·m, 51.6 ft-lb)

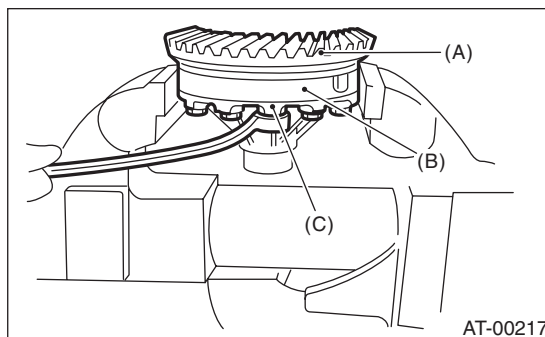

- (A) Hypoid driven gear
- (B) Differential case (RH)
- (C) Differential case (LH)

5) Measurement of backlash (Selection of washer)
(1) Install the SUBARU genuine axle shaft to differential case.

Part No. 38415AA070 AXLE SHAFT

(2) Measure the gear backlash using ST1 and ST2, and then insert the ST2 through the access window of case.

ST1 498247001 MAGNET BASE

ST2 498247100 DIAL GAUGE

NOTE:

- Measure the backlash by applying a pinion tooth between two bevel gear teeth.
- Fix the bevel pinion gear in place with a screwdriver or similar tool when measuring.

Specification:

0.13 — 0.18 mm (0.0051 — 0.0071 in)

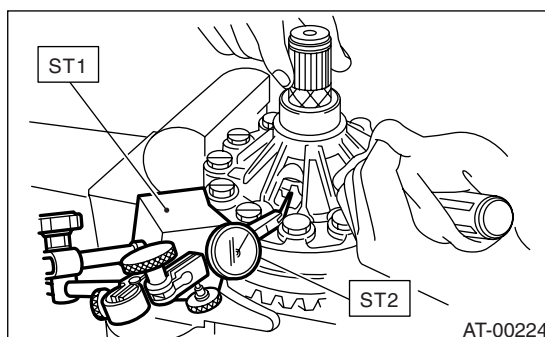

(3) If the backlash is not within specification, select a washer from the table below.

Washer	
Part No.	Thickness mm (in)
803038021	0.95 (0.037)
803038022	1.00 (0.039)
803038023	1.05 (0.041)

6) Using the ST, install the taper roller bearing.
ST 398487700 DRIFT

2. SIDE RETAINER

NOTE:

Install the oil seal and O-ring of side retainer after the adjustment of backlash and tooth contact.

- 1) Install the bearing outer race to side retainer.
- 2) Install a new oil seal using ST.

ST 18675AA000 DIFFERENTIAL SIDE OIL SEAL INSTALLER

NOTE:

Apply oil to the oil seal lips.

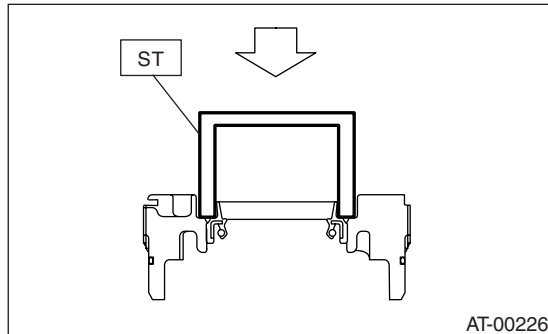

- 3) Install a new O-ring.

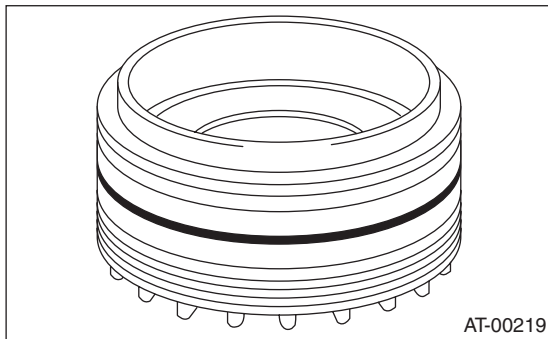

E: INSPECTION

- Check each component for scratches, damage or other faults.
- Measure the backlash, and then adjust it to be within specification.

<Ref. to 5AT-89, ADJUSTMENT, Front Differential Assembly.>

F: ADJUSTMENT

- 1) Using the ST, screw-in the retainer until resistance is felt.

NOTE:

Screw in the RH side slightly deeper than the LH side.

ST 18630AA010 WRENCH

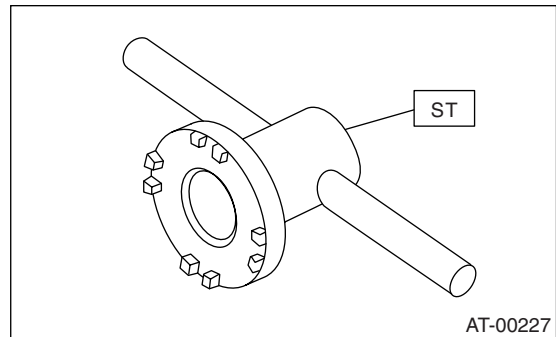

- 2) Remove the oil pump cover.
- 3) Remove the liquid gasket from the mating surface completely.
- 4) Install the oil pump cover to converter case, and secure them with tightening four bolts evenly.

NOTE:

Use an old gasket or aluminum washer to prevent damaging the mating surface of the housing.

Tightening torque:

41 N·m (4.2 kgf·m, 30.4 ft·lb)

- 5) Rotate the drive pinion ten times or more using ST1 and ST2.

ST1 18667AA010 HOLDER

ST2 499787700 WRENCH

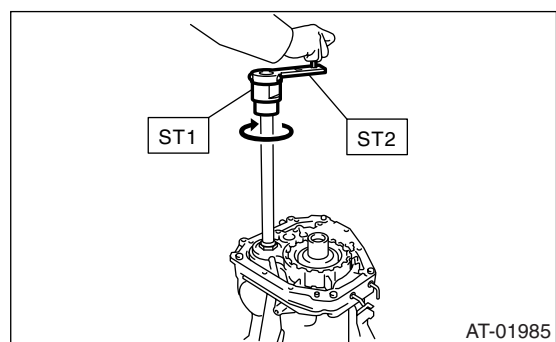

Front Differential Assembly

AUTOMATIC TRANSMISSION

6) Tighten the LH retainer by rotating the shaft until resistance is felt. Then loosen the retainer RH. Keep tightening the retainer LH, and loosening the retainer RH until the pinion shaft no longer be turned. This is the “zero” state.

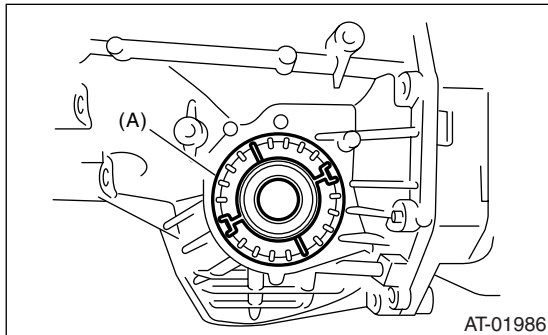

(A) Retainer

7) After the “zero” state is established, back off the retainer LH 3 notches and secure it with the lock plate. Then back off the retainer RH and retighten until it stops. Rotate the drive pinion 2 or 3 times. Tighten the retainer RH further 1-3/4 notches. This sets the preload. Finally, secure the retainer with its lock plate.

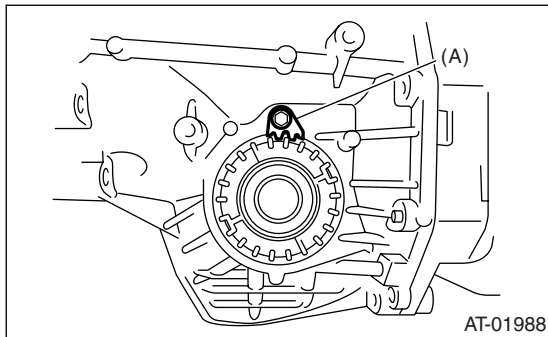

(A) Lock plate

NOTE:

Turning the retainer by one tooth changes the backlash approx. 0.05 mm (0.0020 in).

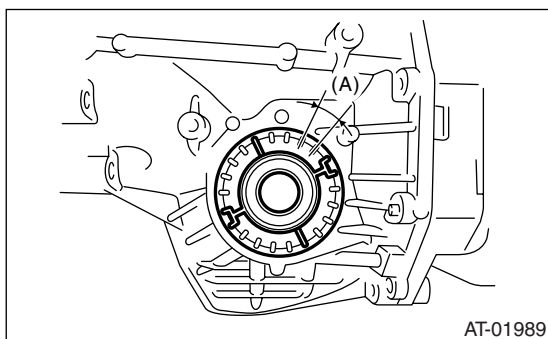

(A) 0.05 mm (0.0020 in)

8) Turn the drive pinion several times using ST1, and check to see if the backlash is within the specification using ST2, ST3, ST4 and ST5.

ST1	499787700	WRENCH
ST2	498247001	MAGNET BASE
ST3	498247100	DIAL GAUGE
ST4	499787500	ADAPTER
ST5	498255400	PLATE

Backlash:

0.10 — 0.15 mm (0.0039 — 0.0059 in)

9) Adjust the teeth contact of the front differential and drive shaft. <Ref. to 5AT-83, ADJUSTMENT, Drive Pinion Shaft Assembly.>