

## 14. Front Vehicle Speed Sensor

### A: REMOVAL

1) Remove the transmission assembly from vehicle body. <Ref. to 5AT-34, REMOVAL, Automatic Transmission Assembly.>

2) Remove the rear vehicle speed sensor.

#### NOTE:

Secure the harness of the rear vehicle speed sensor to the transmission body using wire etc.

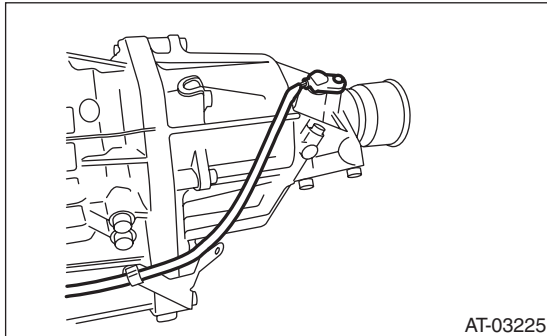

3) Remove the extension case.

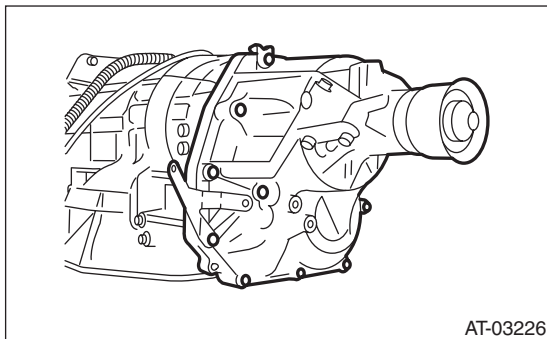

4) Remove the center differential carrier. <Ref. to 5AT-71, REMOVAL, Center Differential Carrier.>

5) Lay along the transmission case, and then remove the oil pan.

6) Remove the old gasket on the oil pan and transmission case completely.

7) Disconnect the front vehicle speed sensor connector.

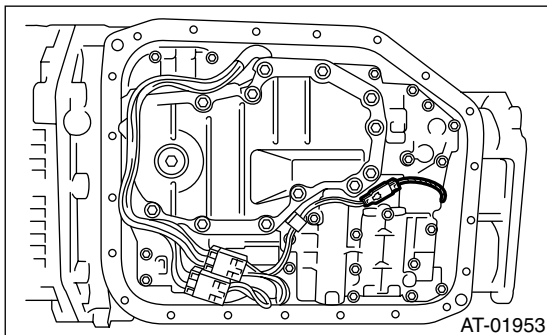

8) Remove the front vehicle speed sensor securing bolt.

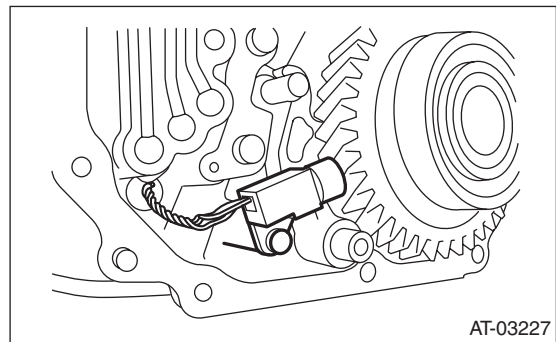

9) Remove the front vehicle speed sensor through the hole of AT transmission main case.

### B: INSTALLATION

1) Install the front vehicle speed sensor.

#### Tightening torque:

**7 N·m (0.7 kgf-m, 5.2 ft-lb)**

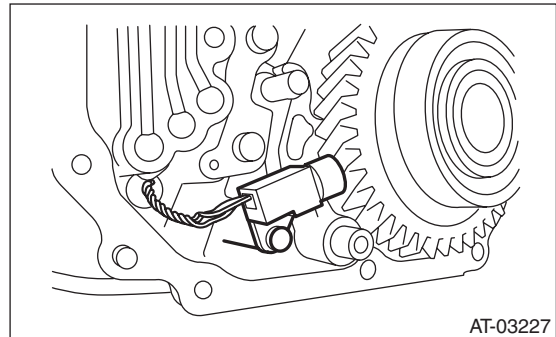

2) Connect the front vehicle speed sensor connector.

3) Apply proper amount of liquid gasket to the entire oil pan mating surface.

#### Liquid gasket:

**THREE BOND 1217B (Part No. K0877YA020)**

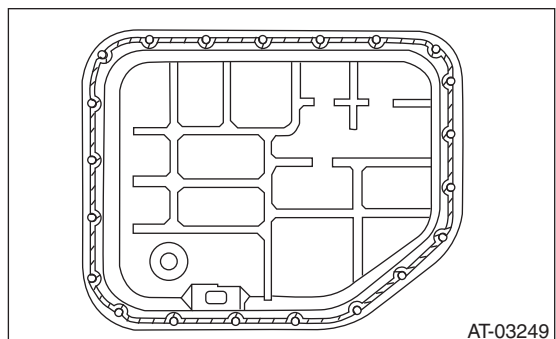

4) Install the oil pan by equally tightening the bolts.

#### Tightening torque:

**5 N·m (0.5 kgf-m, 3.7 ft-lb)**

5) Install the center differential carrier. <Ref. to 5AT-71, INSTALLATION, Center Differential Carrier.>

## Front Vehicle Speed Sensor

### AUTOMATIC TRANSMISSION

---

6) Install the extension case.

**Tightening torque:**

**25 N·m (2.5 kgf·m, 18 ft·lb)**

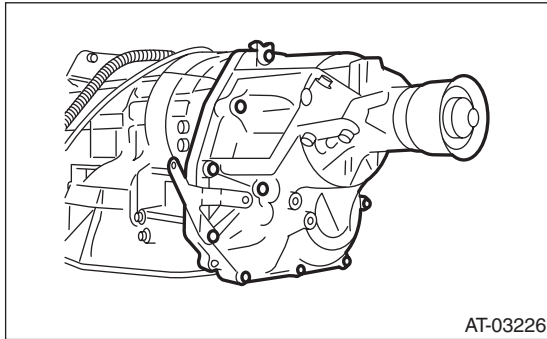

7) Install the rear vehicle speed sensor.

**Tightening torque:**

**7 N·m (0.7 kgf·m, 5.2 ft·lb)**

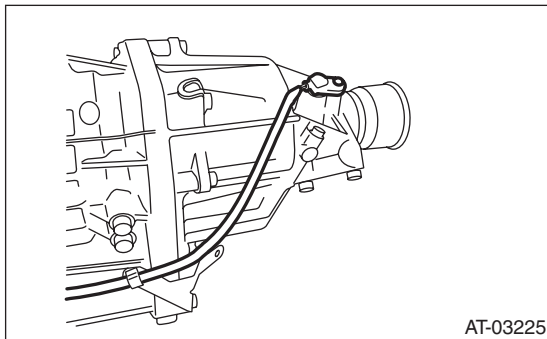

8) Install the transmission assembly to the vehicle.  
<Ref. to 5AT-37, INSTALLATION, Automatic Transmission Assembly.>

9) Pour ATF from the oil charge pipe. <Ref. to 5AT-26, REPLACEMENT, Automatic Transmission Fluid.>

10) Check the level and leaks of ATF. <Ref. to 5AT-26, INSPECTION, Automatic Transmission Fluid.>