

## 31.Oil Pump Cover

### A: REMOVAL

- 1) Remove the transmission assembly from vehicle body. <Ref. to 5AT-34, REMOVAL, Automatic Transmission Assembly.>
- 2) Pull out the torque converter assembly. <Ref. to 5AT-62, REMOVAL, Torque Converter Assembly.>
- 3) Remove the transmission harness connector from stay.
- 4) Remove the oil charge pipe. <Ref. to 5AT-61, REMOVAL, Oil Charge Pipe.>
- 5) Remove the ATF filter inlet and outlet pipes. <Ref. to 5AT-57, REMOVAL, ATF Cooler Pipe & Hose.>
- 6) Separate the converter case and transmission case. <Ref. to 5AT-75, REMOVAL, Converter Case.>
- 7) Remove the oil pump cover mounting bolt, and then separate the oil pump cover from the AT main case by lightly tapping with plastic hammer.

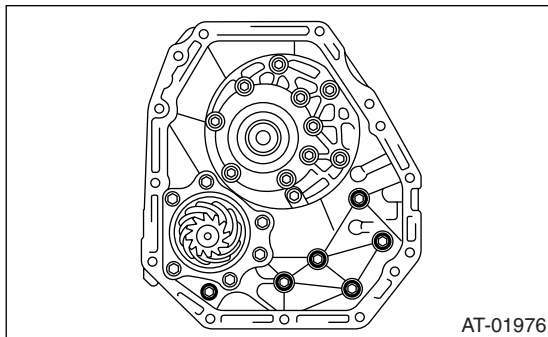

### B: INSTALLATION

- 1) Secure the oil pump cover.

#### *Tightening torque:*

**41 N·m (4.2 kgf-m, 30.4 ft-lb)**

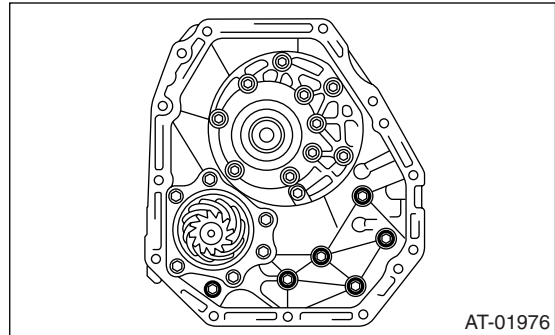

- 2) Install the converter case assembly to the transmission case assembly. <Ref. to 5AT-62, INSTALLATION, Torque Converter Assembly.>
- 3) Install the transmission harness connector to the stay.
- 4) Install the ATF filter pipe. <Ref. to 5AT-58, INSTALLATION, ATF Cooler Pipe & Hose.>
- 5) Install the oil charge pipe together with an O-ring. <Ref. to 5AT-61, INSTALLATION, Oil Charge Pipe.>
- 6) Install the torque converter assembly. <Ref. to 5AT-62, INSTALLATION, Torque Converter Assembly.>
- 7) Install the transmission assembly to the vehicle. <Ref. to 5AT-37, INSTALLATION, Automatic Transmission Assembly.>

### C: DISASSEMBLY

#### 1. FRONT BRAKE

- 1) Remove the snap ring.

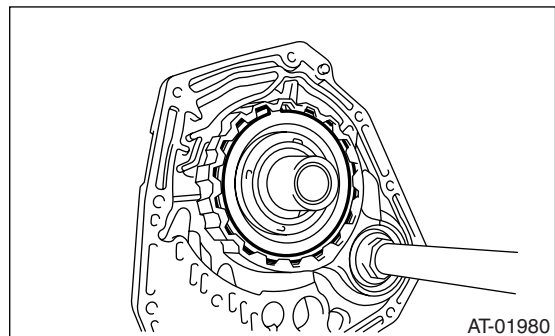

- 2) Remove the retainer plate, drive plate and driven plate.

# Oil Pump Cover

## AUTOMATIC TRANSMISSION

3) Using the ST1, ST2 and ST3, remove the snap ring.

ST1 18762AA000 COMPRESSOR SPECIAL TOOL

ST2 18765AA000 COMPRESSOR SUPPORT

ST3 18763AA000 COMPRESSOR SHAFT

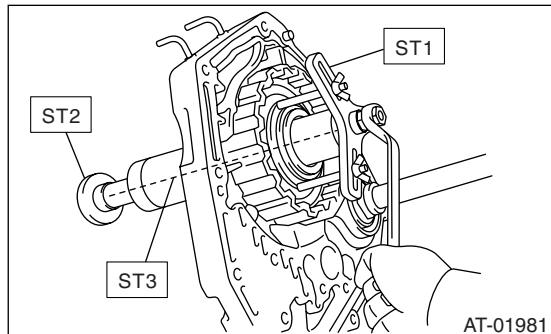

4) Remove the retainer and return spring.

5) Remove the front brake piston using compressed air.

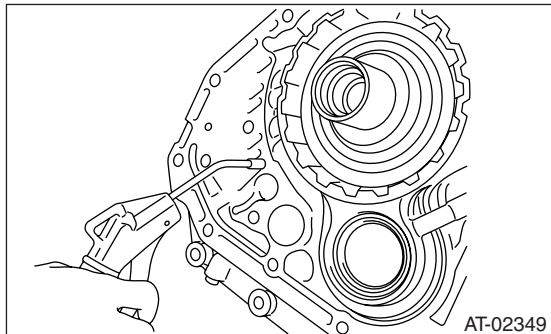

6) Remove the D-ring from front brake piston.

## 2. OIL PUMP

1) Take out the oil pump housing.

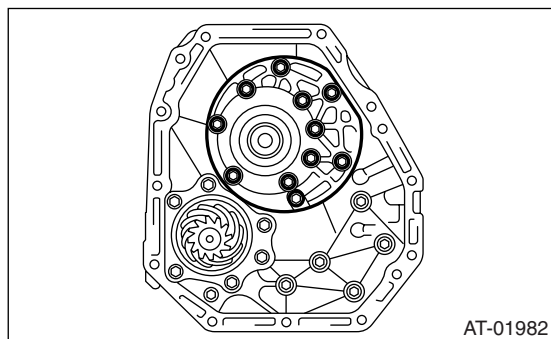

2) Take out the oil pump body.

## D: ASSEMBLY

### 1. FRONT BRAKE

1) Apply ATF to D-ring, and then install it to the front brake piston.

2) Install the front brake piston to oil pump cover.

NOTE:

Install by aligning the "▲" mark on front brake piston surface with the oil pump cover rib.

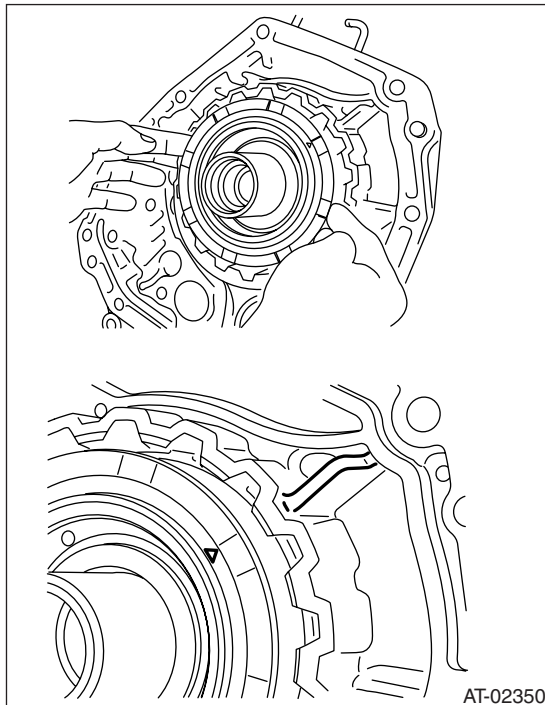

3) Install the retainer and return spring.

4) Install the front brake piston assembly using ST1, ST2 and ST3.

ST1 18762AA000 COMPRESSOR SPECIAL TOOL

ST2 18765AA000 COMPRESSOR SUPPORT

ST3 18763AA000 COMPRESSOR SHAFT

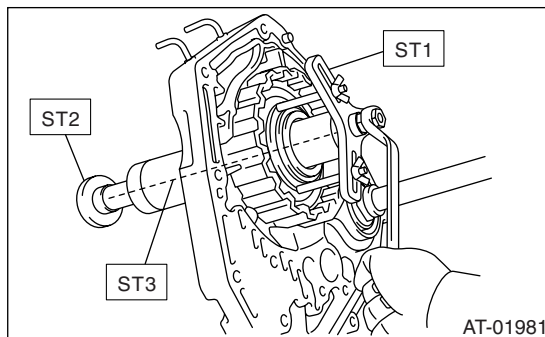

5) Install the genuine driven plate instead of retainer plate, and temporarily assemble the drive plate and driven plate.

Part No. 31536AA290 Driven plate

6) Install the snap ring.

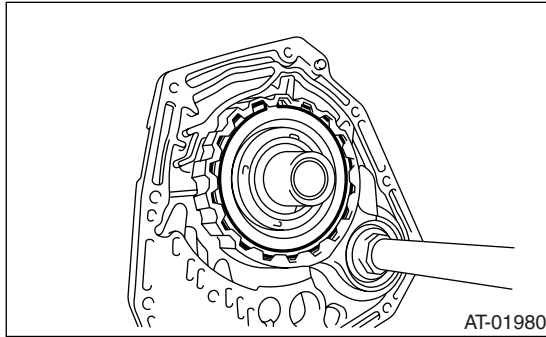

7) Measure the clearance between retainer plate and snap ring, and then select the suitable retainer plate from table.

**Front brake clearance specification:**  
**0.7 — 1.1 mm (0.028 — 0.043 in)**

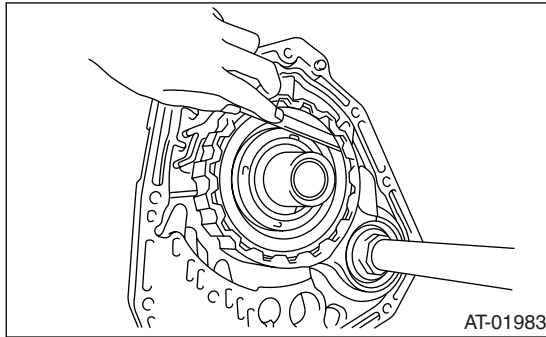

Front brake retainer plate	
Part No.	Thickness mm (in)
31567AB130	3.4 (0.134)
31567AB140	3.6 (0.142)
31567AB150	3.8 (0.150)
31567AB160	4.0 (0.157)

8) Remove the snap ring, replace the driven plate used in measurement of clearance with the retainer plate, and then reassemble.

## 2. OIL PUMP

- 1) Apply ATF to oil pump assembly, and then install it to oil pump housing.
- 2) Install the O-ring to oil pump cover.
- 3) Install the oil pump housing to the oil pump cover.

**Tightening torque:**  
**10 N·m (1.0 kgf·m, 7.4 ft·lb)**

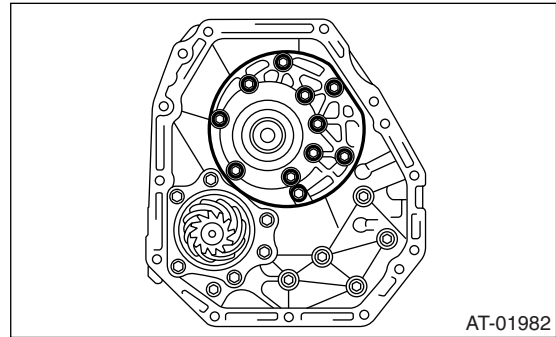

# Oil Pump Cover

AUTOMATIC TRANSMISSION

## E: INSPECTION

### 1. FRONT BRAKE

Check the following items.

- Drive plate facing for wear and damage
- Snap ring for wear, return spring for damage, and retainer for damage
- Piston for damage
- D-ring for damage

### 2. OIL PUMP

Check the following items.

- Oil pump cover and oil seal for breakage or damage
  - Oil pump body for scratch or damage
- 1) Check the seal ring and oil seal for breaks and damage.

2) Check other parts for dents or faults.

3) Oil pump rotor assembly selection

(1) Tip clearance

Install the inner rotor and outer rotor to oil pump housing. With rotor gears facing each other, measure the crest-to-crest clearance.

**Tip clearance:**

**0.02 — 0.15 mm (0.0008 — 0.0059 in)**

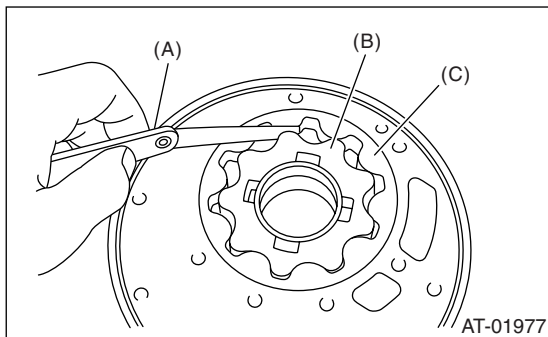

- (A) Thickness gauge
- (B) Inner rotor
- (C) Outer rotor

(2) Side clearance

Set a depth gauge to oil pump housing, then measure the oil pump housing-to-rotor clearance.

**Side clearance:**

**0.02 — 0.045 mm (0.0008 — 0.0018 in)**

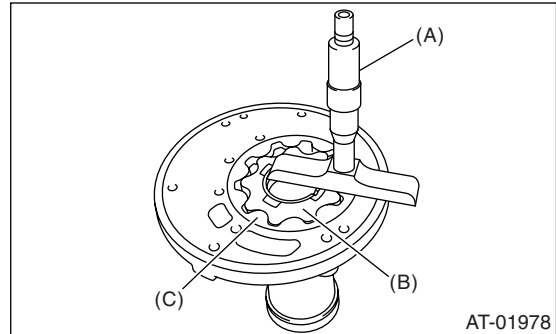

- (A) Depth gauge
- (B) Inner rotor
- (C) Outer rotor

(3) If the depth and/or side clearance are not within the specification, replace the rotor assembly.

Oil pump rotor assembly	
Part No.	Thickness mm (in)
15008AA130	11.37 — 11.38 (0.4476 — 0.4480)
15008AA140	11.38 — 11.39 (0.4480 — 0.4484)
15008AA150	11.39 — 11.40 (0.4484 — 0.4488)

Measure the total end play and adjust it to be within specifications. <Ref. to 5AT-99, ADJUSTMENT, AT Main Case.>