

26.Rear Drive Shaft

A: REMOVAL

- 1) Remove the transmission assembly from vehicle body. <Ref. to 5AT-34, REMOVAL, Automatic Transmission Assembly.>
- 2) Remove the rear vehicle speed sensor, and then remove the extension case. <Ref. to 5AT-63, REMOVAL, Extension Case.>
- 3) Pull out the rear driveshaft from center differential assembly.

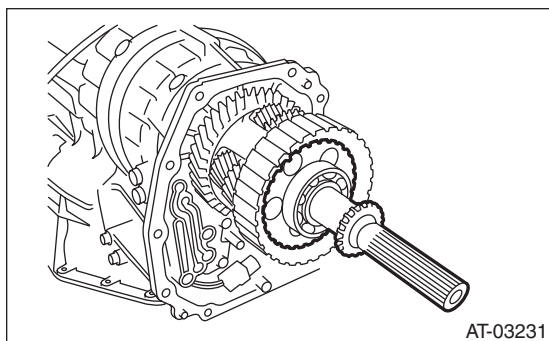

- 4) Remove the drive plate and driven plate.

B: INSTALLATION

- 1) Select the shim. <Ref. to 5AT-65, ADJUSTMENT, Transfer Clutch.>
- 2) Install drive plate and driven plate.
- 3) Insert the rear driveshaft into the center differential assembly.
- 4) Combine the extension case, and then install the rear vehicle speed sensor. <Ref. to 5AT-63, INSTALLATION, Extension Case.>
- 5) Install the transmission assembly to the vehicle. <Ref. to 5AT-37, INSTALLATION, Automatic Transmission Assembly.>

C: DISASSEMBLY

- 1) Using a press, remove the revolution gear.

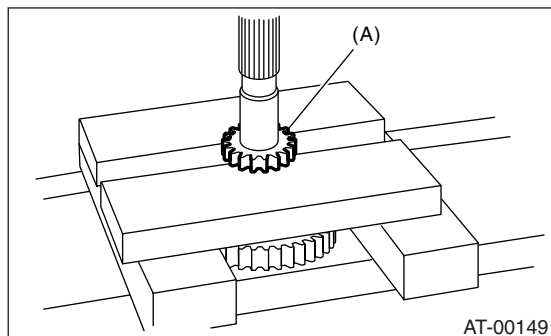

(A) Revolution gear

- 2) Using a press, remove the front and rear side ball bearings and clutch hub.

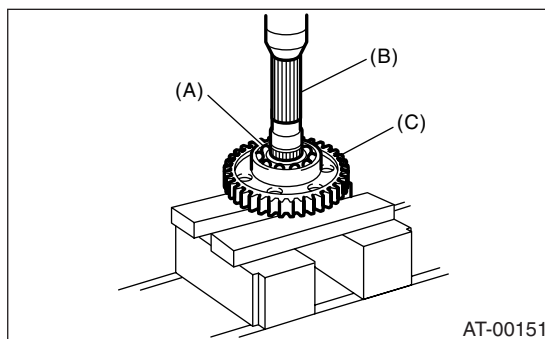

(A) Rear ball bearing
(B) Rear drive shaft
(C) Clutch hub

D: ASSEMBLY

Assemble in the reverse order of disassembly.

NOTE:

- Use new ball bearings and revolution gear.
- Make sure the clutch hub is facing the correct direction.

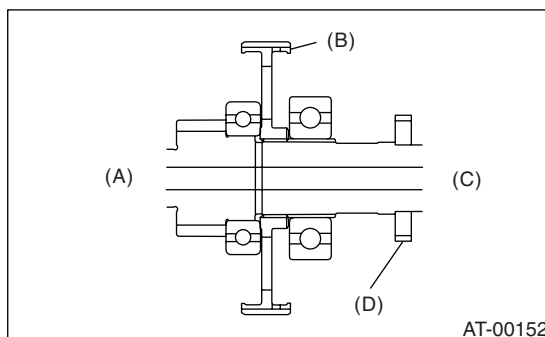

(A) Front side
(B) Clutch hub
(C) Rear side
(D) Revolution gear

E: INSPECTION

- Check each parts for holes, damages or other foreign matters.
- Inspect the extension end play, and adjust it to within the standard value. <Ref. to 5AT-65, ADJUSTMENT, Transfer Clutch.>