

25. Transfer Clutch

A: REMOVAL

- 1) Remove the transmission assembly from vehicle body. <Ref. to 5AT-34, REMOVAL, Automatic Transmission Assembly.>
- 2) Remove the extension case, and then remove the transfer clutch. <Ref. to 5AT-63, REMOVAL, Extension Case.>, <Ref. to 5AT-63, DISASSEMBLY, Extension Case.>

B: INSTALLATION

- 1) Select the rear drive shaft shim. <Ref. to 5AT-65, ADJUSTMENT, Transfer Clutch.>
- 2) Select driven plate No. 3. <Ref. to 5AT-65, ADJUSTMENT, Transfer Clutch.>
- 3) Install the extension case. <Ref. to 5AT-63, INSTALLATION, Extension Case.>
- 4) Install the transmission assembly to the vehicle. <Ref. to 5AT-37, INSTALLATION, Automatic Transmission Assembly.>

C: INSPECTION

- Inspect the drive plate facing for wear and damage.
- Make sure the snap ring is not worn and the return spring has no permanent distortion, damage, or deformation.
- Check that the D-ring is not damaged.
- Inspect the extension end play, and adjust it to within the standard value. <Ref. to 5AT-65, ADJUSTMENT, Transfer Clutch.>

D: ADJUSTMENT

1. REAR DRIVE SHAFT SHIM SELECTION

- 1) Insert the rear drive shaft into the reduction drive gear and center differential assembly.

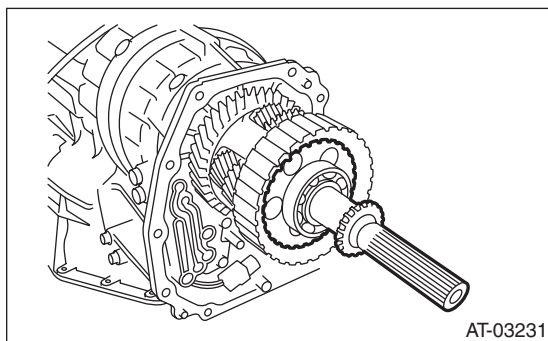

- 2) Using the ST, measure the depth “A”, which is from mating surface of extension case to ball bearing outer ring contact surface.
ST 398643600 GAUGE

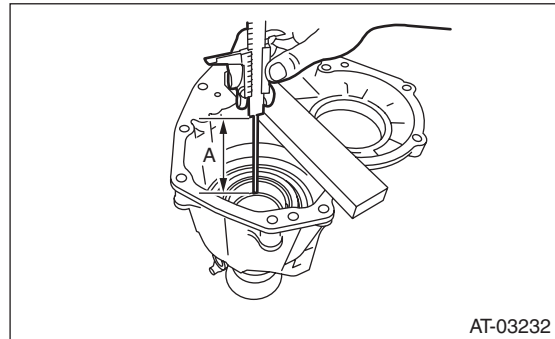

A Measured value

- 3) Using the ST, measure the height “B” from the AT main case mating surface to ball bearing outer ring contact surface.
ST 398643600 GAUGE

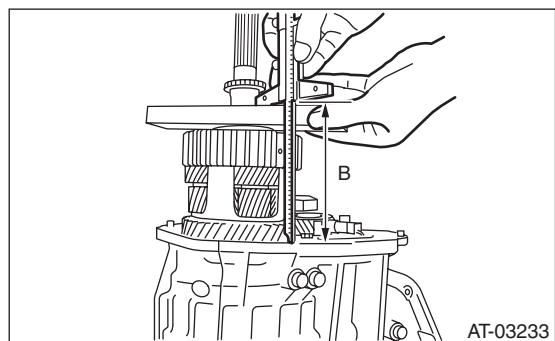

B Measured value

- 4) Calculation formula:
When clearances are 0.05 mm (0.0020 in):
 $T \text{ (mm)} = A - B + 0.23$
 $[T \text{ (in)} = A - B + 0.009]$
When clearances are 0.25 mm (0.0098 in):
 $T \text{ (mm)} = A - B + 0.03$
 $[T \text{ (in)} = A - B + 0.001]$
A: Depth from end of extension case to ball bearing outer ring contact surface
B: Height from end of AT main case contact surface to the ball bearing outer ring contact surface
T: Shim thickness

Specification:

0.05 — 0.25 mm (0.0020 — 0.0098 in)

NOTE:

Calculation formula for “T” above is applied when measuring with the ST (398643600 GAUGE).
When not using the ST,

Transfer Clutch

AUTOMATIC TRANSMISSION

When clearances are 0.05 mm (0.0020 in):

$$T \text{ (mm)} = (A - \alpha) - ((B - \beta) - 0.28) - 0.05$$

$$[T \text{ (in)} = (A - \alpha) - ((B - \beta) - 0.011) - 0.0020]$$

When clearances are 0.25 mm (0.0098 in):

$$T \text{ (mm)} = (A - \alpha) - ((B - \beta) - 0.28) - 0.25$$

$$[T \text{ (in)} = (A - \alpha) - ((B - \beta) - 0.011) - 0.0098]$$

is applied.

T: Shim thickness

A: Depth from end of extension case to ball bearing outer ring contact surface

B: Height from end of AT main case contact surface to the ball bearing outer ring contact surface

α : Thickness of collar used when measuring "A"

β : Thickness of collar used when measuring "B"

0.28 (0.011): Gasket thickness (Unit mm (in))

Adjustment shim	
Part No.	Thickness mm (in)
33281AA040	0.2 (0.008)
33281AA050	0.5 (0.020)
33281AA060	0.3 (0.012)

2. SELECTION OF DRIVEN PLATE NO. 3

1) Install the drive plate and driven plate to the center differential carrier.

2) Measure the depth "A" from the mating surface of the extension case to the multi-plate clutch (LSD) piston.

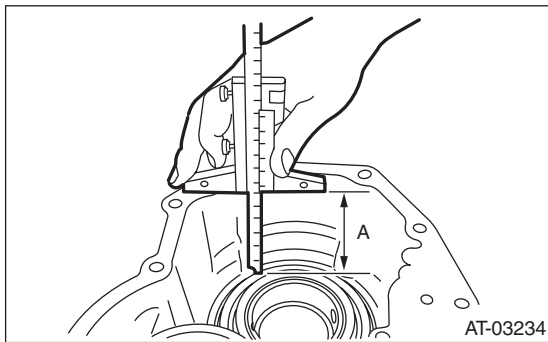

3) Using the ST, measure the height "B" from the AT main case mating surface to end of ST, and then subtract the thickness of ST (piston guide) (50 mm (1.97 in)) from measured value.

ST 398744300 PISTON GUIDE

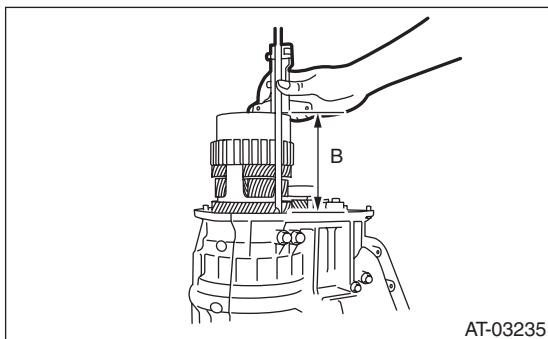

4) Calculation formula:

When clearances are 0.2 mm (0.008 in):

$$T \text{ (mm)} = A - B + 0.08$$

$$[T \text{ (in)} = A - B + 0.0031]$$

When clearances are 0.6 mm (0.024 in):

$$T \text{ (mm)} = A - B + 0.32$$

$$[T \text{ (in)} = A - B + 0.0126]$$

T: Thickness of driven plate No. 3

A: Depth from mating surface of extension case to multi-plate clutch (LSD) piston

B: Height from AT main case mating surface to end of ST

Specification:

0.2 — 0.6 mm (0.008 — 0.024 in)

NOTE:

Calculation formula for "T" is applied when measuring using ST (398643600 GAUGE, 398744300 PISTON GUIDE). When not using the ST,

When clearances are 0.2 mm (0.008 in):

$$T \text{ (mm)} = A - (B - \alpha - 0.28) - 0.2$$

$$[T \text{ (in)} = A - (B - \alpha - 0.011) - 0.008]$$

When clearances are 0.6 mm (0.024 in):

$$T \text{ (mm)} = A - (B - \alpha - 0.28) - 0.6$$

$$[T \text{ (in)} = A - (B - \alpha - 0.011) - 0.024]$$

is applied.

T: Thickness of driven plate No. 3

A: Depth from mating surface of extension case to multi-plate clutch (LSD) piston

B: Height from the AT main case mating surface to the contact face of the tool that was used as the substitute of the ST.

α : Thickness of tool used when measuring "B"

0.28 (0.011): Gasket thickness (Unit mm (in))

If it is out of specification, select the driven plate No. 3 to adjust within the specification.

Driven plate No. 3.	
Part No.	Thickness mm (in)
31589AA041	1.6 (0.063)
31589AA050	2.0 (0.079)
31589AA060	2.4 (0.094)
31589AA070	2.8 (0.110)