

## 3. Select Lever

### A: REMOVAL

- 1) Set the vehicle on a lift.
- 2) Disconnect the ground cable from battery.
- 3) Shift the select lever to "N" range.
- 4) Lift-up the vehicle.
- 5) Remove the rear exhaust pipe and muffler. <Ref. to EX(H6DO)-6, REMOVAL, Rear Exhaust Pipe.> <Ref. to EX(H6DO)-8, REMOVAL, Muffler.>
- 6) Remove the heat shield cover.
- 7) Remove the cable from arm assembly.

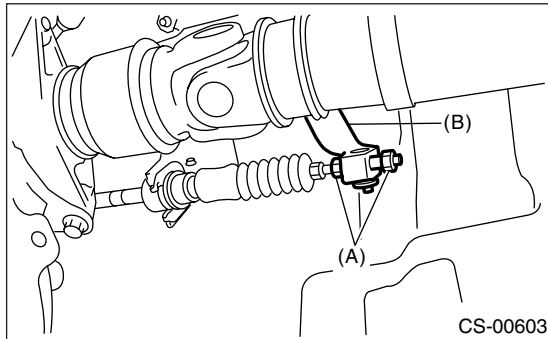

- (A) Adjusting nut
- (B) Arm ASSY

- 8) Raise the pawl of clamp to remove the cable.

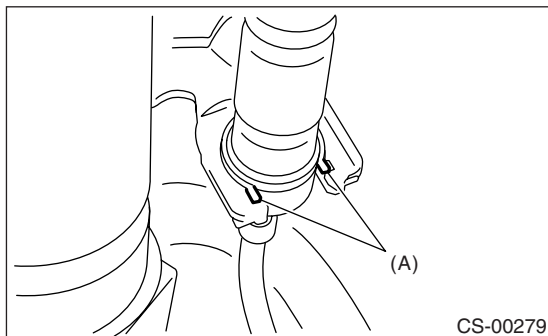

- (A) Claw

- 9) Lower the vehicle.
- 10) Remove the console box. <Ref. to EI-38, REMOVAL, Console Box.>
- 11) Remove the center console. <Ref. to EI-39, REMOVAL, Center Console.>

- 12) Remove all harnesses from the select lever.

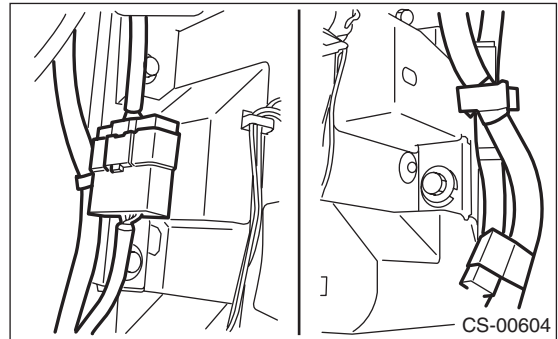

- 13) Disconnect the connectors, and then remove the four bolts to take out the select lever assembly from vehicle body.

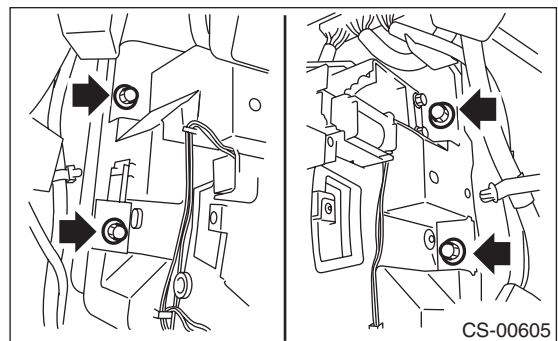

### B: INSTALLATION

- 1) Set the select lever to vehicle body.
- 2) Tighten the four bolts to install the select lever to vehicle body, and then connect the connector.
  - (1) Temporarily tighten the bolt A.
  - (2) Tighten the bolt B.
  - (3) Tighten the bolt A.
  - (4) Tighten the bolts C and D.

#### Tightening torque:

**18 N·m (1.8 kgf-m, 13.3 ft-lb)**

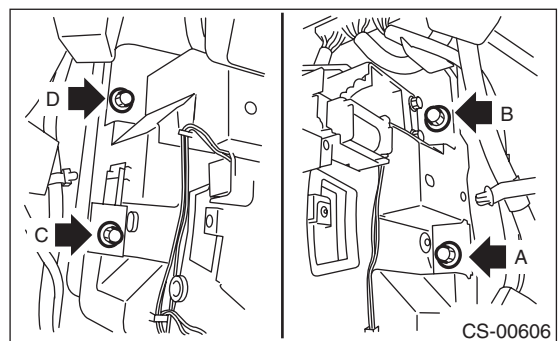

# Select Lever

## CONTROL SYSTEMS

3) Install the shift select cable onto select lever.

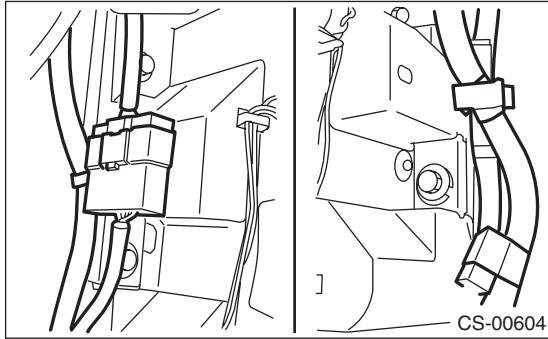

4) Install the center console. <Ref. to EI-39, INSTALLATION, Center Console.>

5) Install the console box. <Ref. to EI-38, INSTALLATION, Console Box.>

6) Shift the select lever to “N” range.

7) Lift-up the vehicle.

8) Shift the range select lever to the “N” range.

9) Secure the cable to the bracket. <Ref. to CS-26, INSTALLATION, Select Cable.>

10) Adjust the select cable position. <Ref. to CS-28, ADJUSTMENT, Select Cable.>

11) After the completion of adjustment, confirm that the select lever operates properly at all range positions.

12) Install the heat shield cover.

13) Install the rear exhaust pipe and muffler. <Ref. to EX(H6DO)-7, INSTALLATION, Rear Exhaust Pipe.> <Ref. to EX(H6DO)-8, INSTALLATION, Muffler.>

14) Inspect the following items. When a malfunction is found in the inspection, adjust the select cable. <Ref. to CS-28, ADJUSTMENT, Select Cable.>

(1) Engine starts when the select lever is in “P” and “N” range, but not in other ranges.

(2) Back-up light illuminates when the select lever is in the “R” range, but not in other ranges.

(3) Select lever and indicator positions are matched.

## C: DISASSEMBLY

1) Shift the select lever to “N” range.

2) Lower the grip cover.

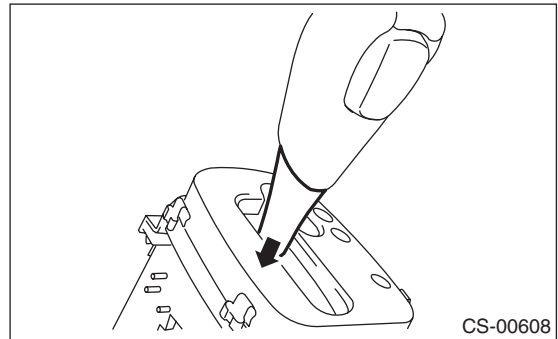

3) Remove the grip pin.

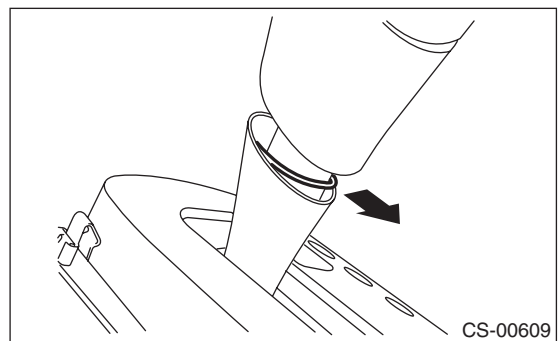

4) Remove the grip assembly.

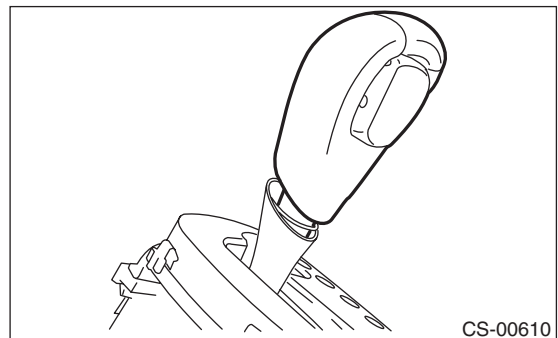

5) Remove the grip cover.

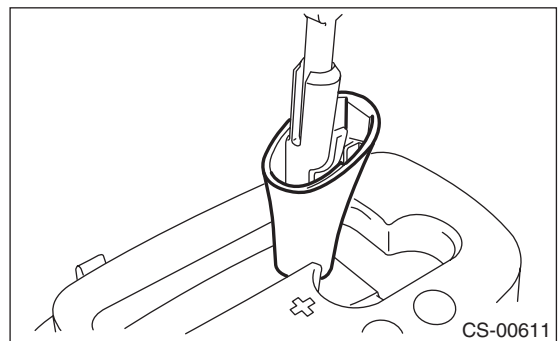

6) Remove the indicator lamp and then remove the bulb.

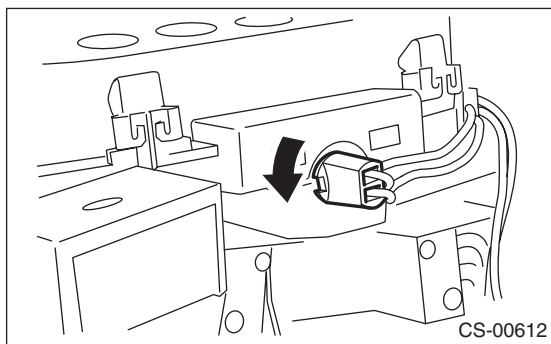

7) Remove the shift lock solenoid assembly.

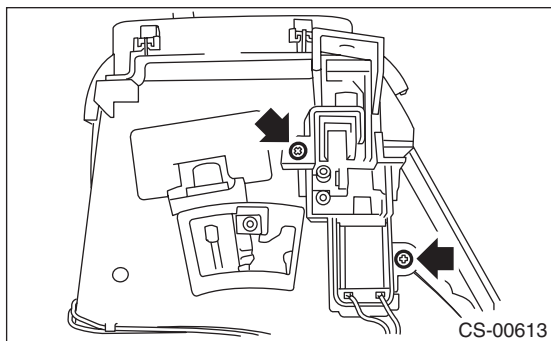

8) Remove the indicator assembly.

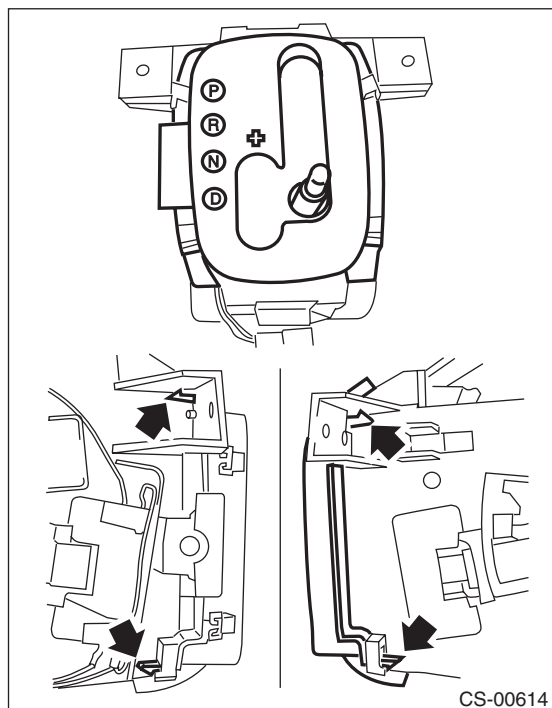

9) Remove the bulb case.

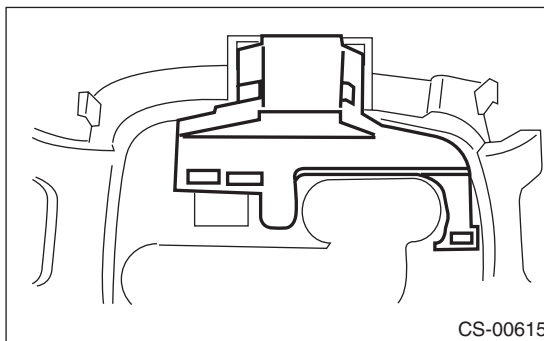

10) Remove the plate lamp guide.

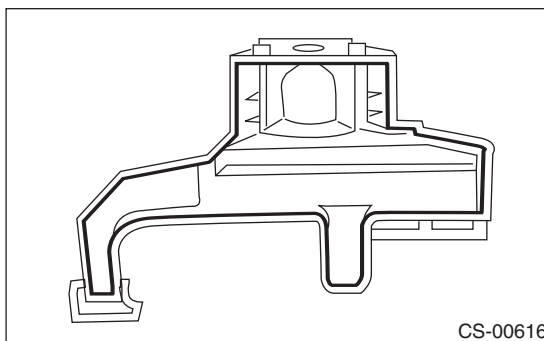

11) Remove the position plate.

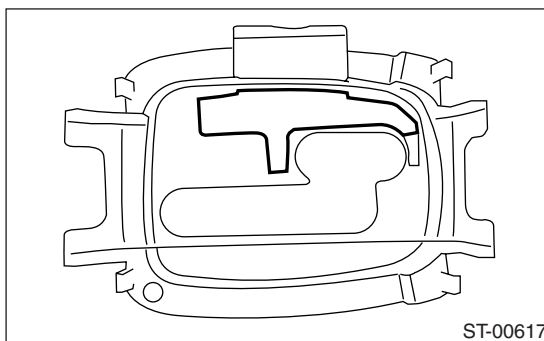

12) Remove the blind assembly.

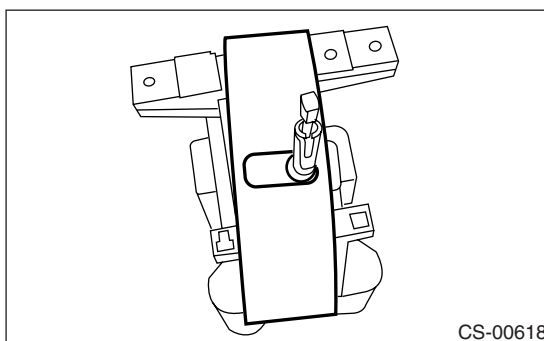

# Select Lever

## CONTROL SYSTEMS

13) Remove blind A and B.

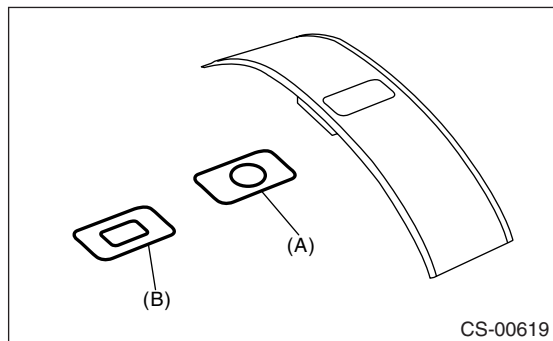

- (A) Blind A
- (B) Blind B

14) Remove the clip while being careful not to break the pin, and remove all switches.

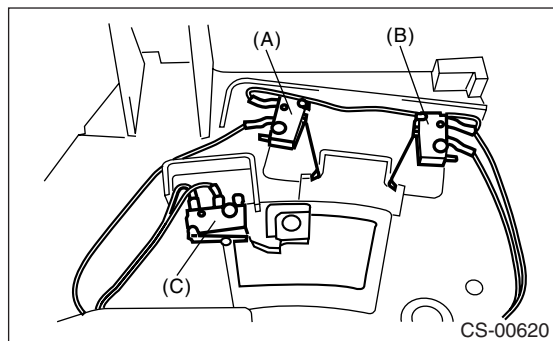

- (A) Shift-up switch
- (B) Shift-down switch
- (C) "P" range switch

15) Remove the connector from the base assembly using a flat-tip screwdriver.

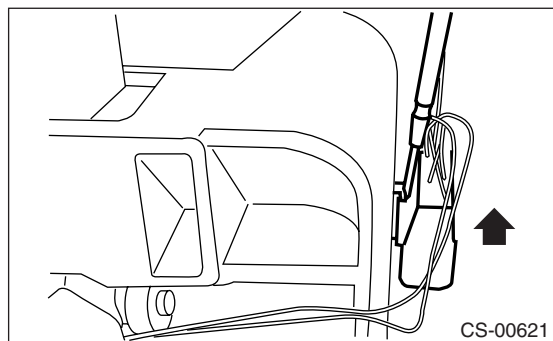

16) Remove all terminals from the connectors using a flat-tip screwdriver.

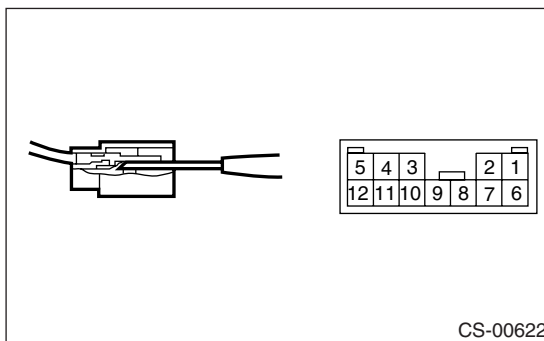

17) Remove the shift lock solenoid from the lock lever bracket.

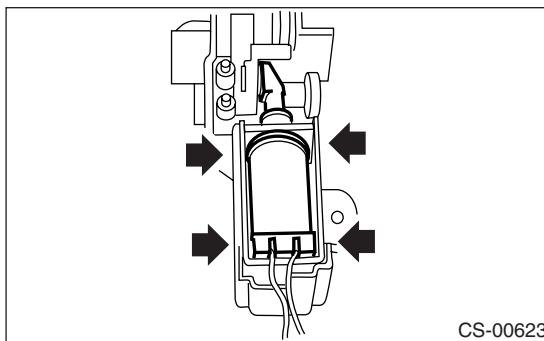

18) Remove the bushing.

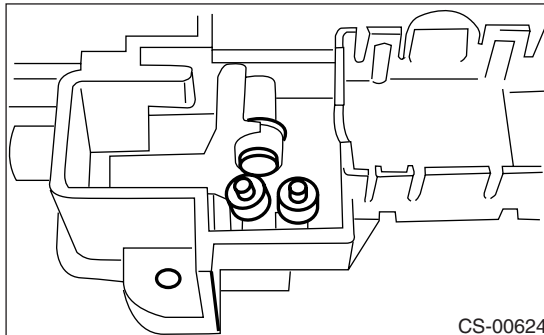

19) Remove the lock lever bushing.

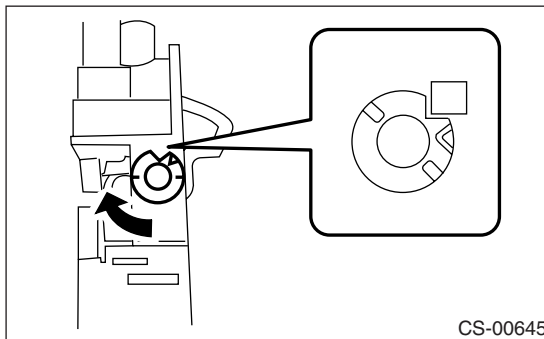

20) Remove the lock lever.

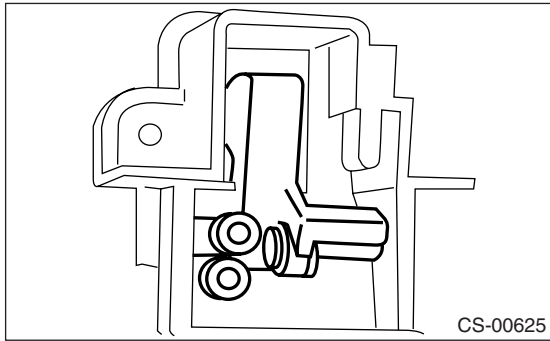

21) Remove the release rod and spring.

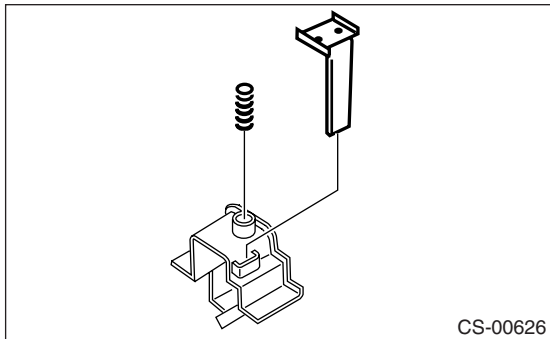

22) Remove the cable bracket.

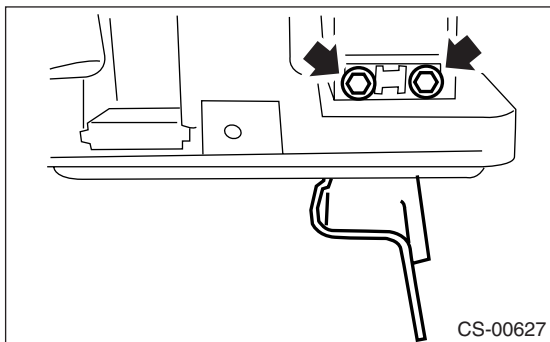

23) Remove the spacer.

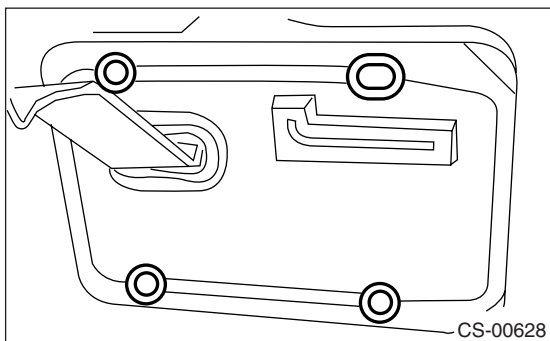

24) Remove the dust cover and dust cover bracket.

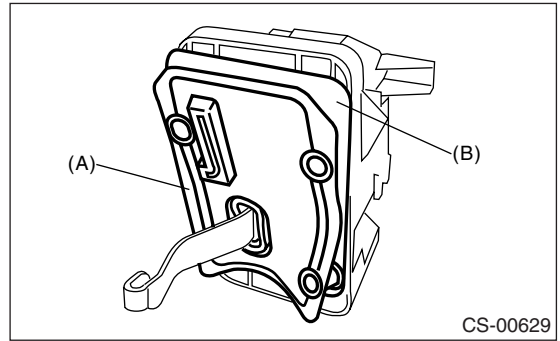

(A) Dust cover  
(B) Dust cover bracket

25) Remove the spacer.

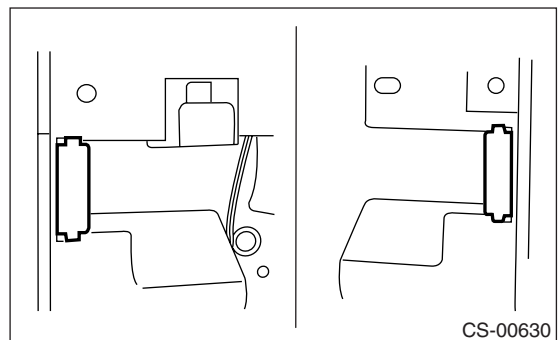

26) Using a press, remove the shift position pin.

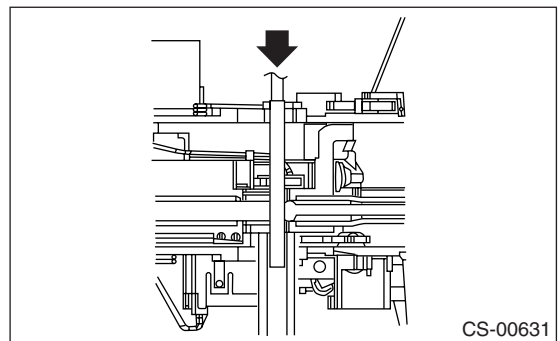

27) Remove the clips, then remove the shaft.

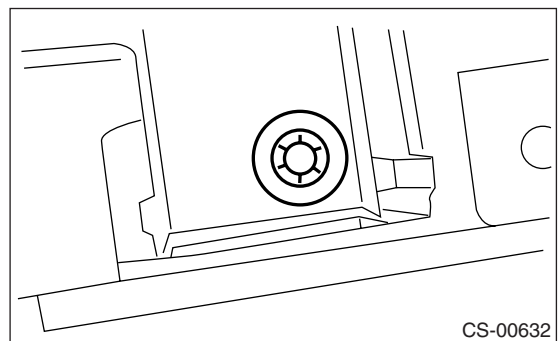

28) Remove the arm assembly.

# Select Lever

## CONTROL SYSTEMS

29) Remove the bushing.

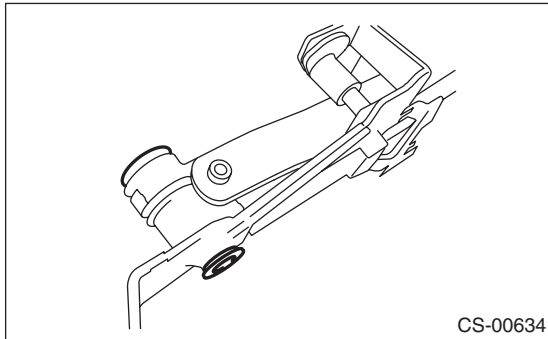

33) Remove the tube cross plate.

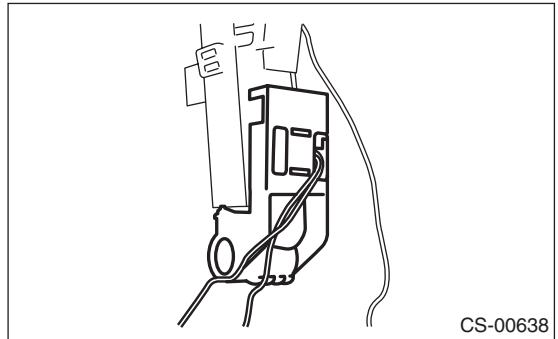

30) Remove the selector arm assembly.

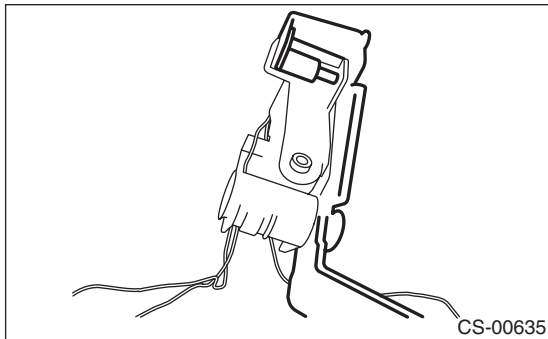

34) Remove the mode change switch.

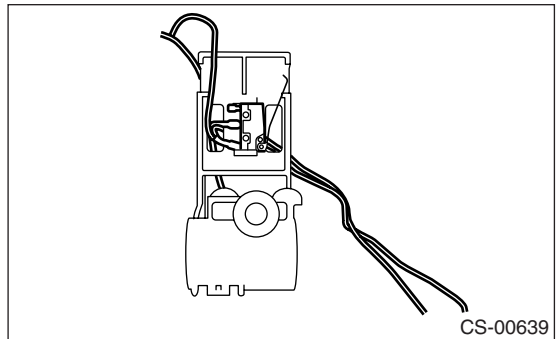

31) Remove the clip while being careful not to break the pin, then remove the shift button switch.

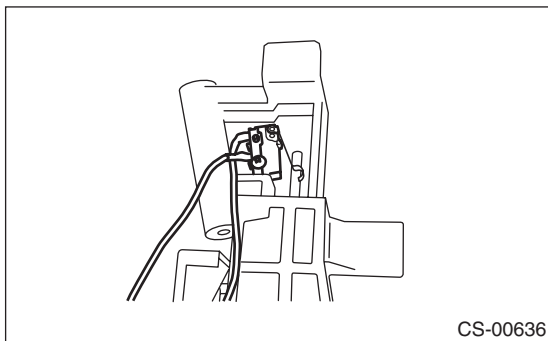

35) Remove the detent check block.

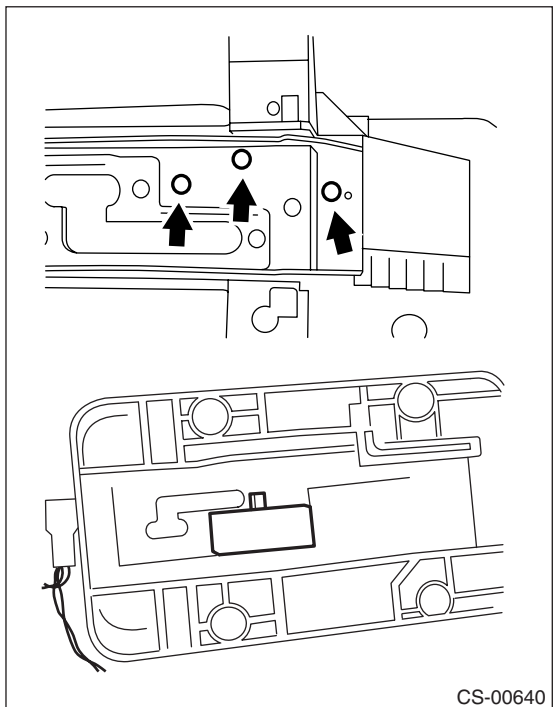

32) Remove the select shaft.

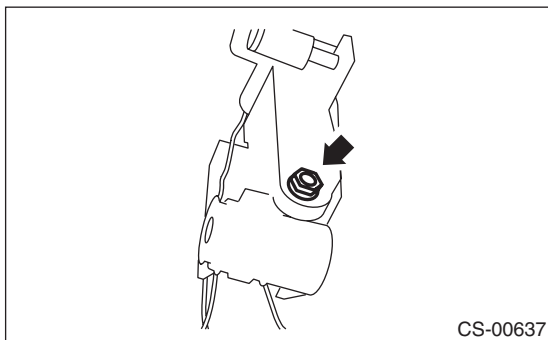

## D: ASSEMBLY

- 1) Clean all the parts before assembly.
- 2) Apply grease [Multemp AC-D, and SH-W or equivalent] to each part. <Ref. to CS-2, AT SELECT LEVER, COMPONENT, General Description.>
- 3) Assemble in the reverse order of disassembly.

### NOTE:

- Refer to “COMPONENT” for each tightening torque. <Ref. to CS-2, AT SELECT LEVER, COMPONENT, General Description.>
- When pressing in the shift position pin, insert from the left side of the vehicle.
- Affix the harness of the shift button switch and the mode change switch at the marked positions.

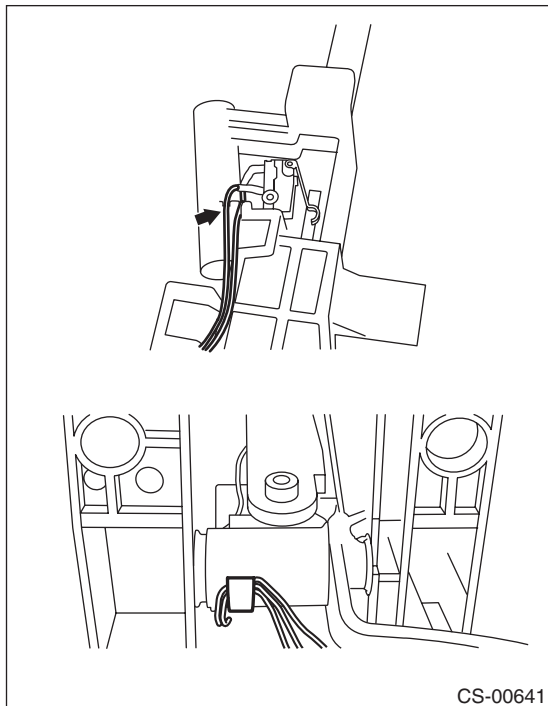

- Connect the terminals of all switches to the respective connectors.

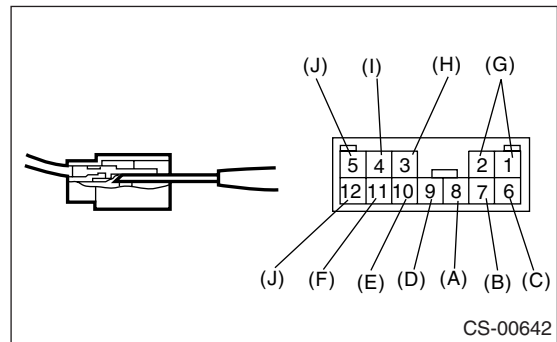

- (A) Mode change switch (color code: Yellow)
- (B) Shift button switch (color code: Brown)
- (C) Mode change switch and shift button switch ground (color code: White)
- (D) Shift up switch (color code: Green)
- (E) Shift up switch (color code: Gray)
- (F) Shift up/down switch ground (color code: Blue)
- (G) “P” range switch (wire color: Red)
- (H) Shift lock solenoid (color code: Blue)
- (I) Shift lock solenoid (color code: Black)
- (J) Indicator lamp (color code: Blue)

- 4) After completing installation, shift the select lever from the “P” range to the “D” range, then check whether or not the selection indicator in the combination meter and the select lever position matches. Also check whether the pointer and position mark matches, and what the operating force is.

## E: INSPECTION

- 1) Inspect the removed parts by comparing with new ones for deformation, damage and wear. Repair or replace if defective.
- 2) Confirm the select lever operating condition before assembly. Normal if it operates smoothly.