

5. Rear Brake Pad

A: REMOVAL

- 1) Lift up the vehicle, and then remove the rear wheels.
- 2) Remove the brake hose bracket.

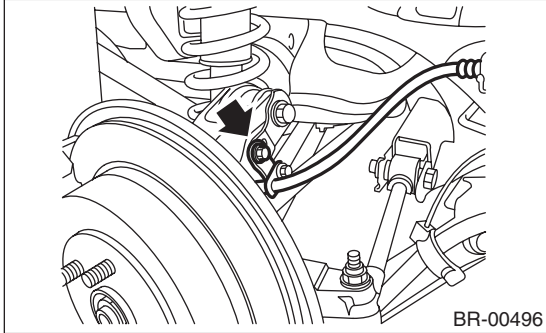

- 3) Remove the caliper bolt.

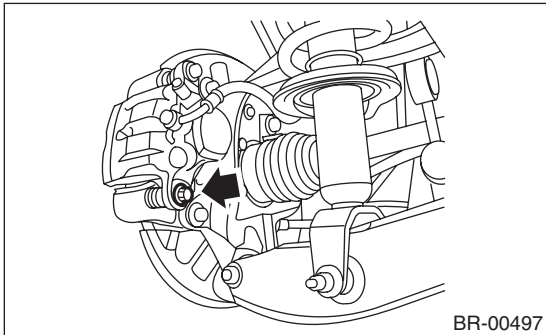

- 4) Raise the caliper body and support it.

NOTE:

Do not disconnect the brake hose from the caliper body.

- 5) Remove the pad.

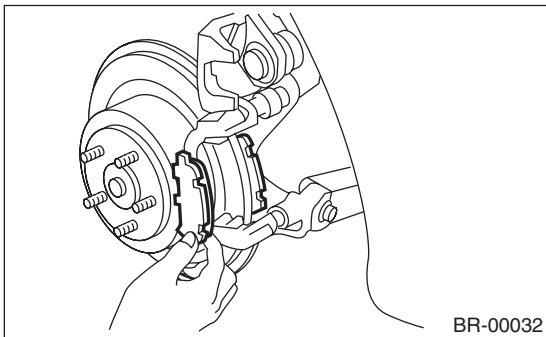

B: INSTALLATION

- 1) Apply a thin coat of Molykote M7439 (Part No. K0770YA000) to the pad clip.

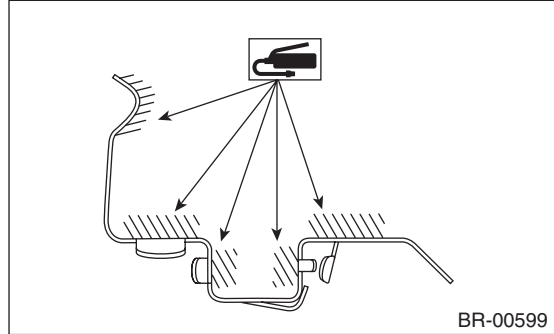

- 2) Apply a thin coat of Molykote AS880N (Part No. K0777YA010) to the contact surface between the pad and shim.

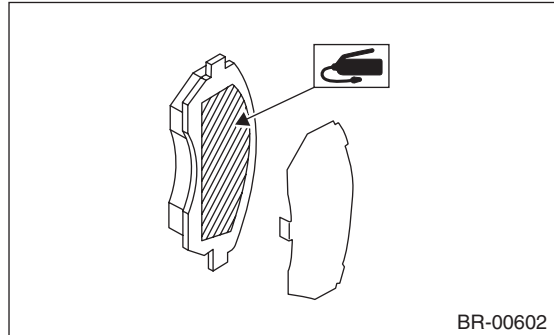

- 3) Apply a thin coat of Molykote AS880N (Part No. K0777YA010) to both sides of pad inner shim.

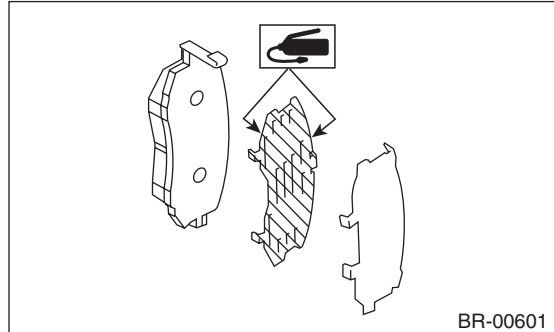

- 4) Install the pad to support.
- 5) Install the caliper body to the support.

Tightening torque:

27 N·m (2.8 kgf-m, 19.9 ft-lb)

- 6) Install the brake hose bracket.

Tightening torque:

33 N·m (3.4 kgf-m, 24.3 ft-lb)

C: INSPECTION

Check thickness A of the pad.

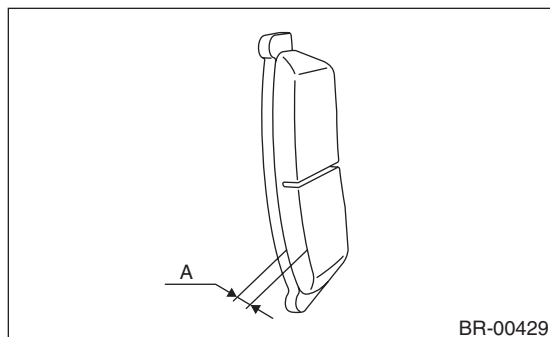

BR-00429

Pad thickness mm (in)	Standard	11.0 (0.433)
	Wear limit	1.5 (0.059)

NOTE:

- Always replace the pads on both sides as a set.
- Replace pad clips if they are twisted or worn.
- A wear indicator is installed on the inner disc brake pad. If the pad is worn to the limit, the end of wear indicator contacts disc rotor, and a squeaking sound is heard as the wheel rotates. If the sound is heard, replace the pad.
- Replace the pad if there is oil or grease on it.