

6. Rear Disc Rotor

A: REMOVAL

- 1) Lift up the vehicle, and then remove the rear wheels.
- 2) Release the parking brake.
- 3) Remove the two mounting bolts, and remove the rear disc brake assembly.

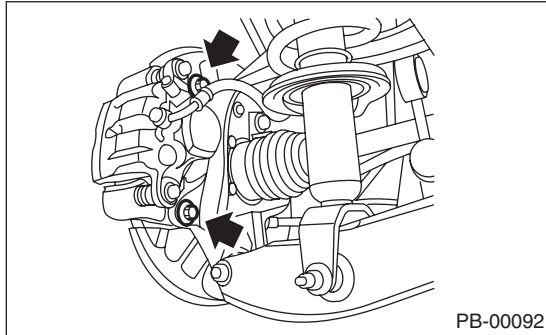

- 4) Suspend the rear disc brake assembly so that the hose is not stretched.
- 5) Remove the rear disc brake rotor.

NOTE:

If the disc rotor is difficult to remove, try the following two methods in order.

- (1) Turn the adjusting screw using a flat tip screwdriver until the brake shoe moves adequately away from the disc rotor.

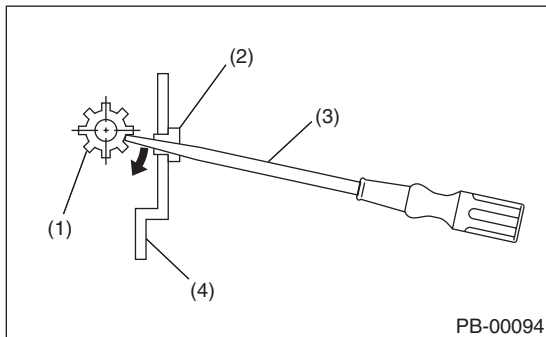

- (1) Adjusting screw
- (2) Cover
- (3) Flat tip screwdriver
- (4) Disc rotor

- (2) If it is difficult to remove the disc rotor from the hub, drive an 8 mm bolt into the threads B of the rotor, then remove the rotor.

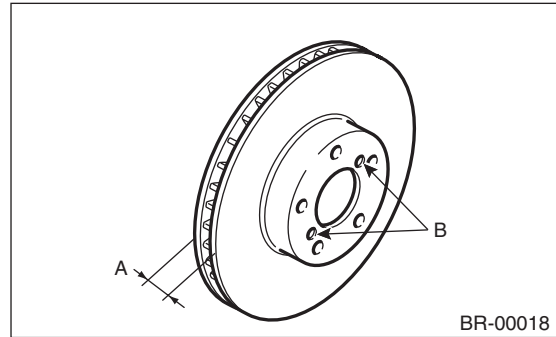

B: INSTALLATION

- 1) Install in the reverse order of removal.

Tightening torque:

66 N·m (6.7 kgf-m, 48.7 ft-lb)

- 2) Adjust the parking brake. <Ref. to PB-9, ADJUSTMENT, Parking Brake Assembly (Rear Disc Brake).>

C: INSPECTION

- 1) Check the rear wheel bearing play and axle hub runout before inspecting the disc rotor runout limit. <Ref. to DS-25, INSPECTION, Rear Hub Unit Bearing.>
- 2) Secure the disc rotor by tightening the five wheel nuts.
- 3) Set a dial gauge 10 mm (0.39 in) inward from the disc rotor outer circumference. Rotate the disc rotor to check runout. If the disc rotor runout exceeds the limit, resurface the disc rotor. After resurfacing, check disc rotor thickness as in step 4).

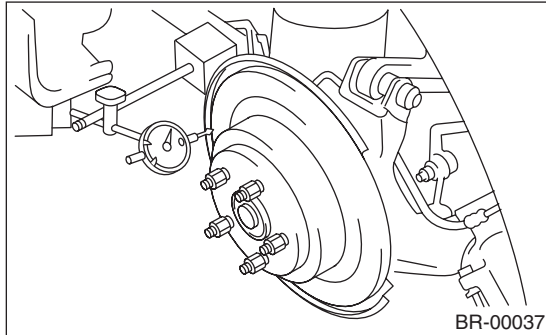

Disc rotor runout limit:
0.05 mm (0.0020 in)

- 4) Set a micrometer 10 mm (0.39 in) inward from the disc rotor outer perimeter, and then measure the disc rotor thickness. If the thickness of disc rotor exceeds the service limit, replace with a new disc rotor.

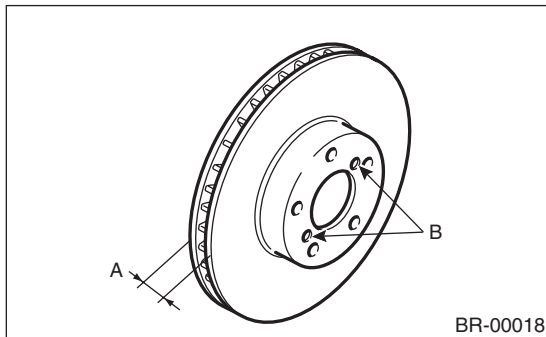

	Specification	Service limit	Disc rotor outer diameter
Disc rotor thickness A mm (in)	18 (0.71)	16 (0.63)	320 (12.59)