

3. Parking Brake Cable

A: REMOVAL

1. FRONT PARKING BRAKE CABLE

- 1) Remove the driver's seat.
- 2) Remove the console box.
- 3) Lift the floor mat.
- 4) Remove the parking brake pedal. <Ref. to PB-4, REMOVAL, Parking Brake Pedal.>
- 5) Roll up the floor mat and remove the clamps.

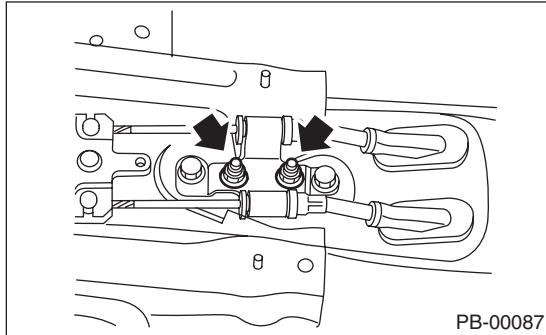

- 6) Remove the cable end from the equalizer.

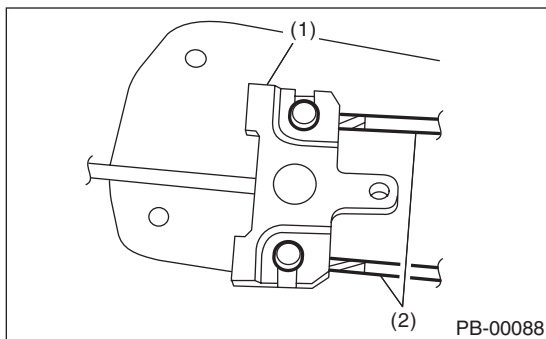

- (1) Equalizer
- (2) Cable end

- 7) Remove the parking brake cable bracket on the driver's side floor, and remove the front parking brake cable.

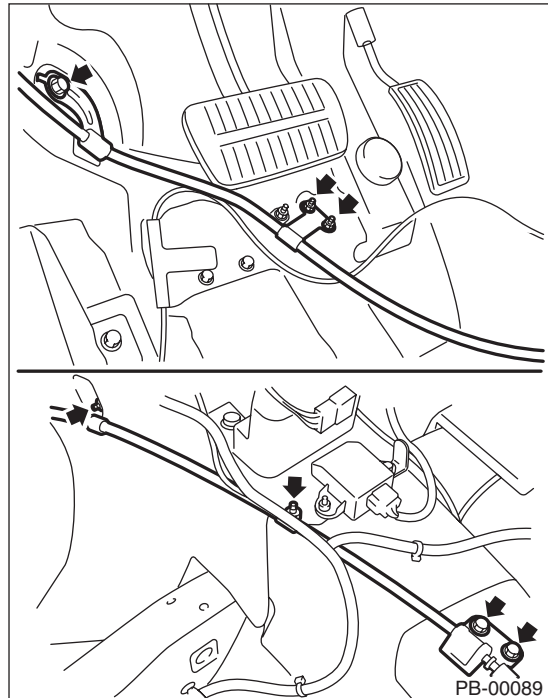

Parking Brake Cable

PARKING BRAKE

2. REAR PARKING BRAKE CABLE

- 1) Set the vehicle on a lift.
- 2) Remove the console box.
- 3) Roll up the floor mat and remove the clamps.

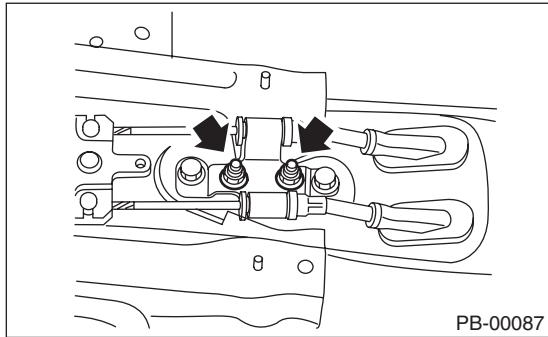

- 4) Remove the cable end from the equalizer.

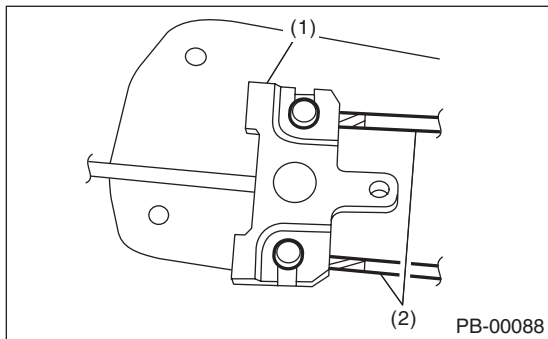

- (1) Equalizer
- (2) Cable end

- 5) Lift up the vehicle, and then remove the rear wheels.
- 6) Remove the rear parking brake cable from the rear brake. <Ref. to PB-7, REMOVAL, Parking Brake Assembly (Rear Disc Brake).>
- 7) Remove the cable clamp, and remove the parking brake cable from the guide.

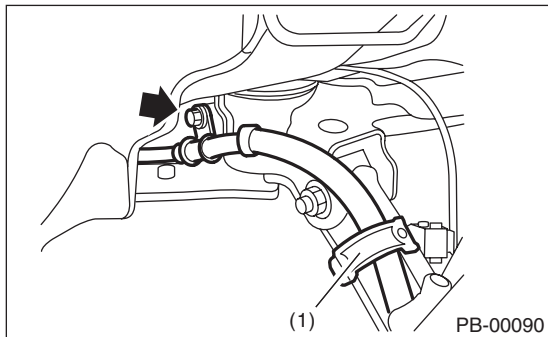

- (1) Guide

- 8) Remove the cable clamp from rear floor.

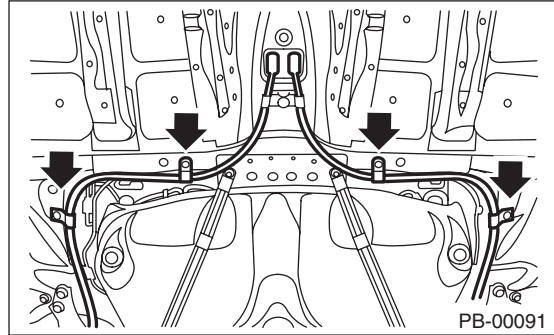

- 9) Remove the cable assembly.

B: INSTALLATION

- 1) Install in the reverse order of removal.
- 2) Adjust the parking brake pedal stroke. <Ref. to PB-4, ADJUSTMENT, Parking Brake Pedal.>

Tightening torque:

<Ref. to PB-2, COMPONENT, General Description.>

C: INSPECTION

Check and replace the removed cable if damaged, rusty or faulty.

- 1) Check the cable for smooth operation.
- 2) Check the front parking brake cable for damage and rust.
- 3) Check the rear parking brake cable for damage, bends and cracks.
- 4) Check the boot for damage, cracks, and corrosion.