

# Power Seat System

WIRING SYSTEM

## 21. Power Seat System

### A: WIRING DIAGRAM

#### 1. DRIVER'S SEAT (WITHOUT MEMORY)

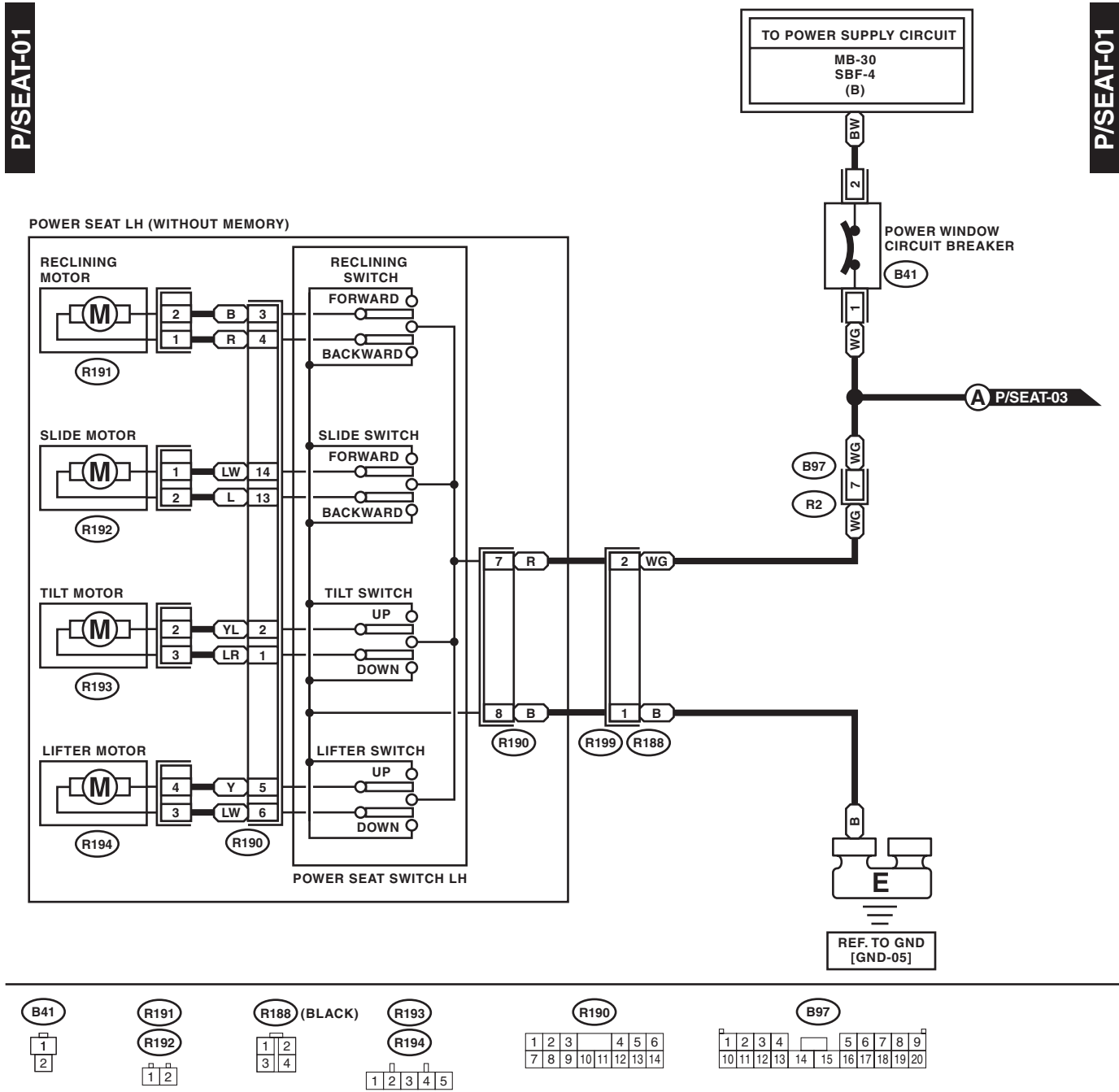

WI-16040

# Power Seat System

WIRING SYSTEM

## 2. DRIVER'S SEAT (WITH MEMORY)

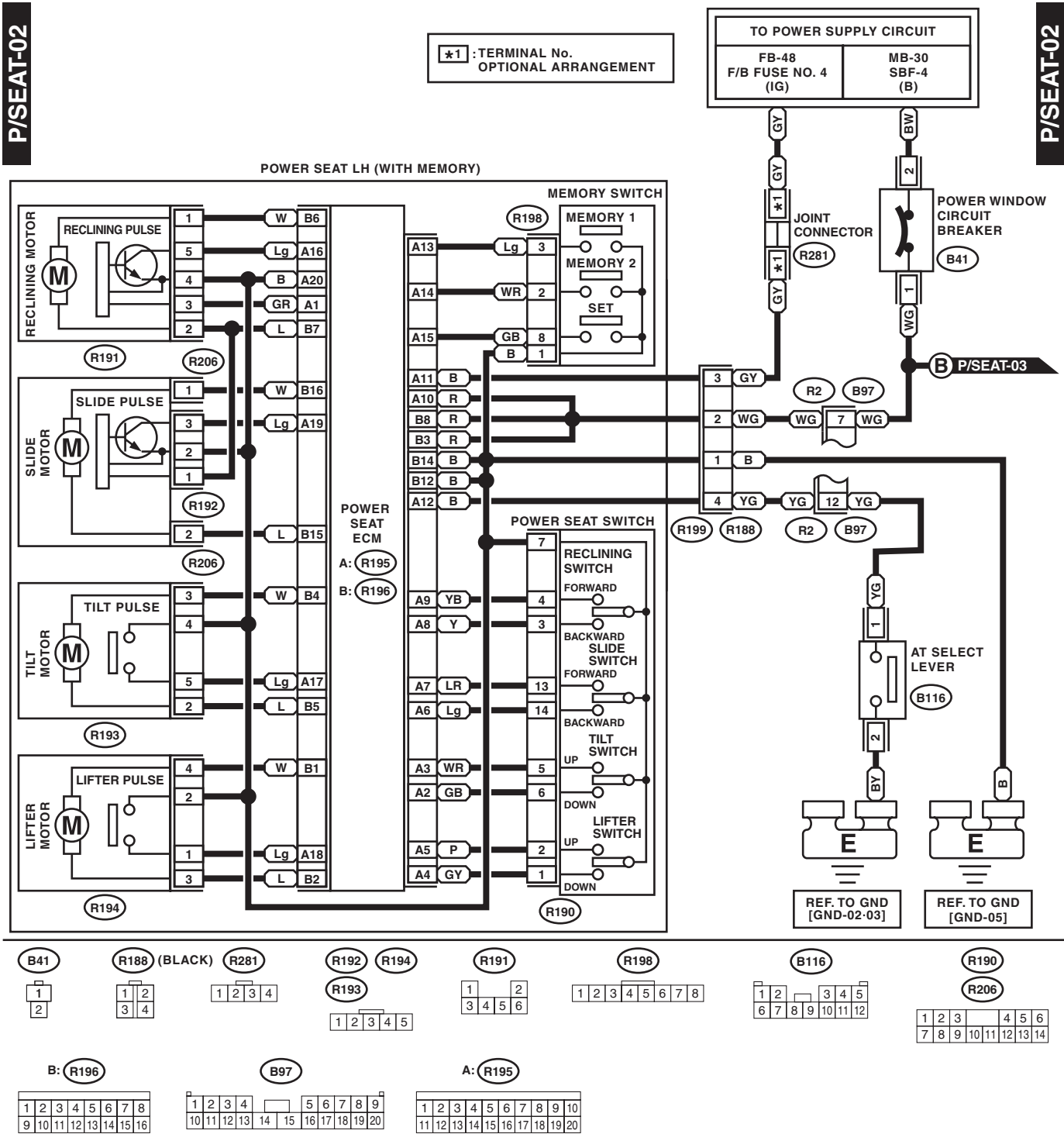

WI-16041

# Power Seat System

## WIRING SYSTEM

### 3. PASSENGER'S SEAT

P/SEAT-03

P/SEAT-03

\*1 : TERMINAL No. OPTIONAL  
 ARRANGEMENT AMONG  
 1, 2, 3, 4, 5 AND 6  
 OM : WITHOUT SEAT MEMORY  
 WM : WITH SEAT MEMORY

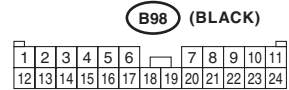
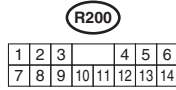
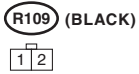
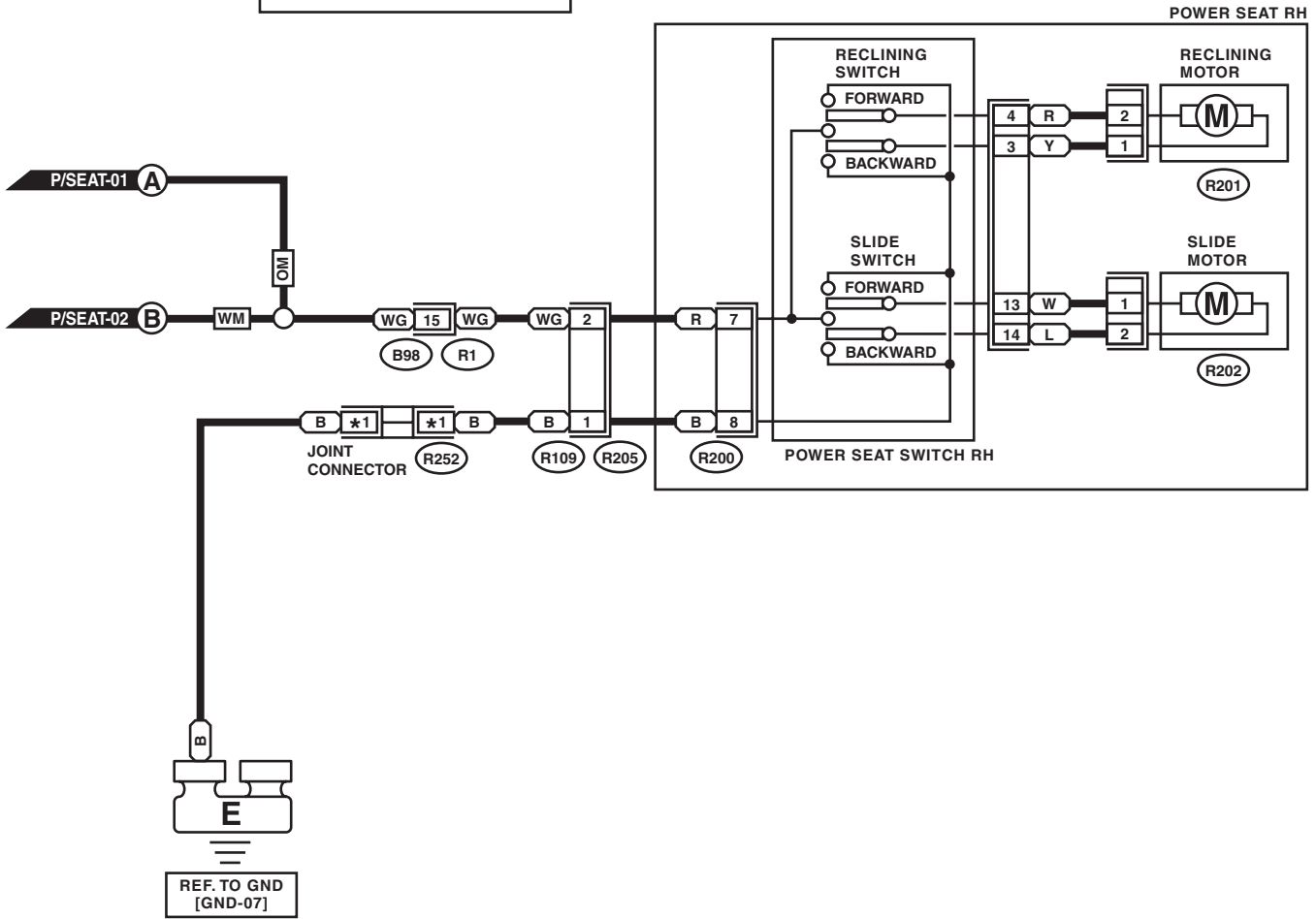

WI-16042