

AT Control System

WIRING SYSTEM

7. AT Control System

A: WIRING DIAGRAM

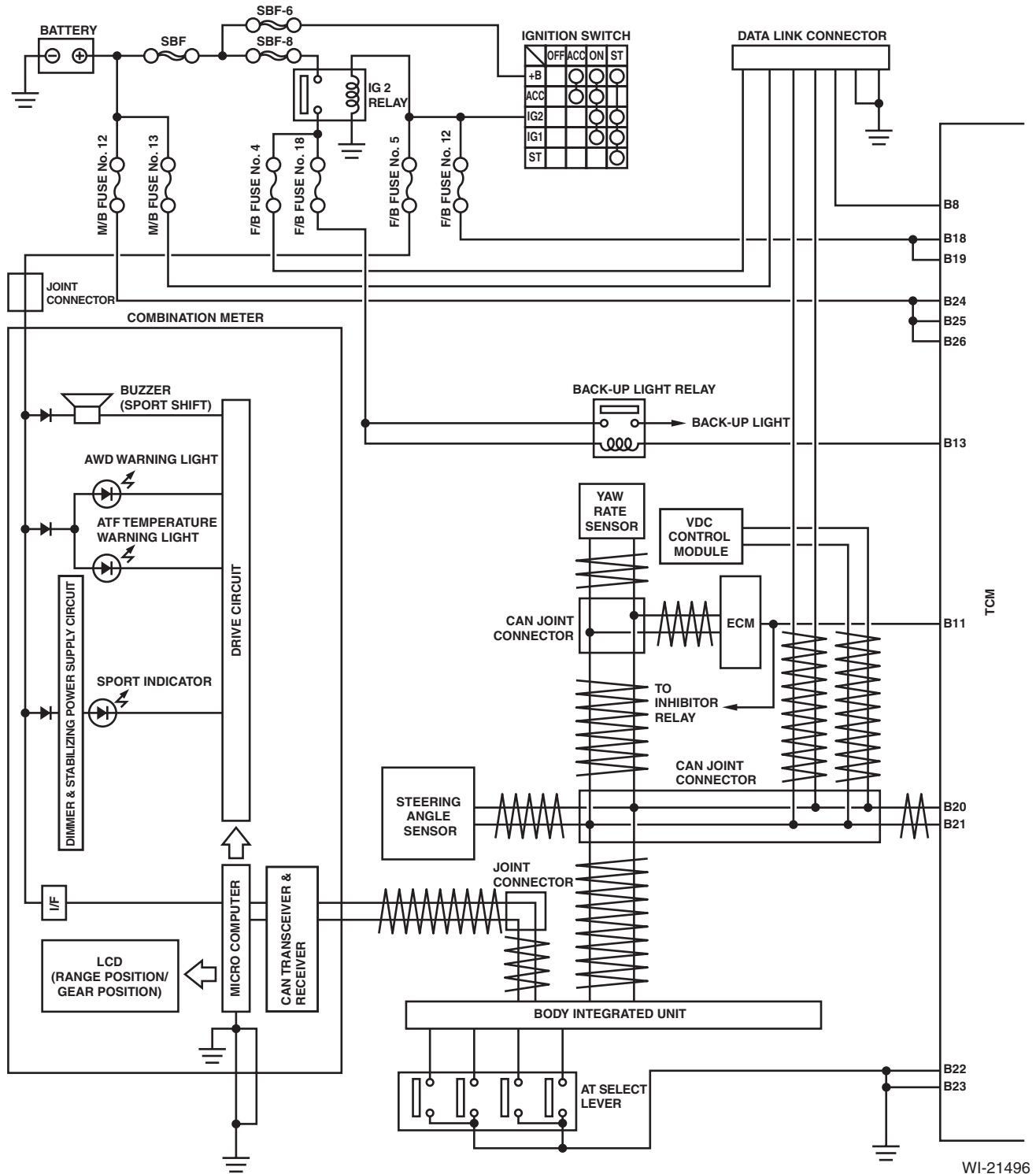

WI-21496

AT Control System

WIRING SYSTEM

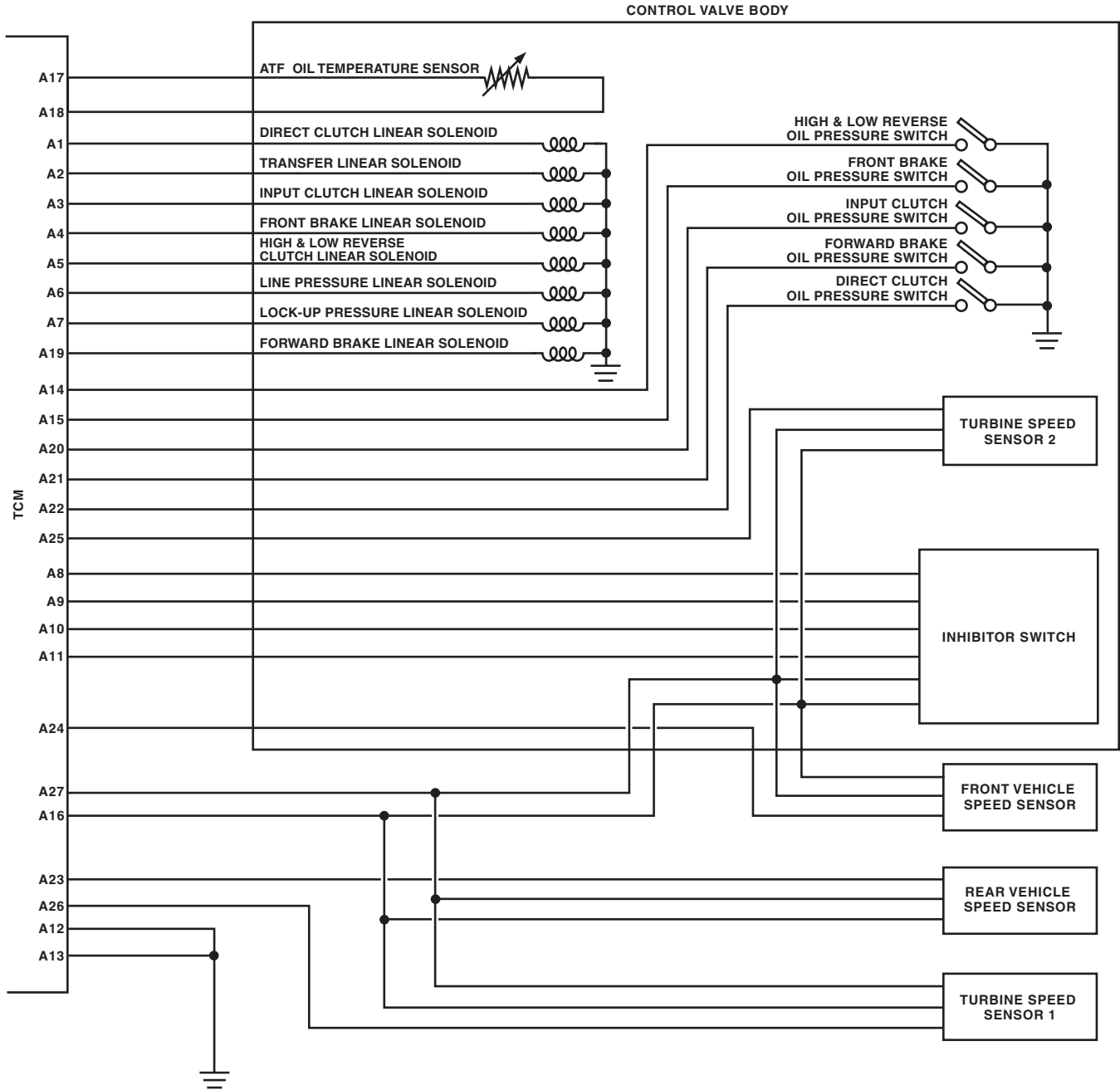

WI-16005

AT Control System

WIRING SYSTEM

5AT-01

5AT-01

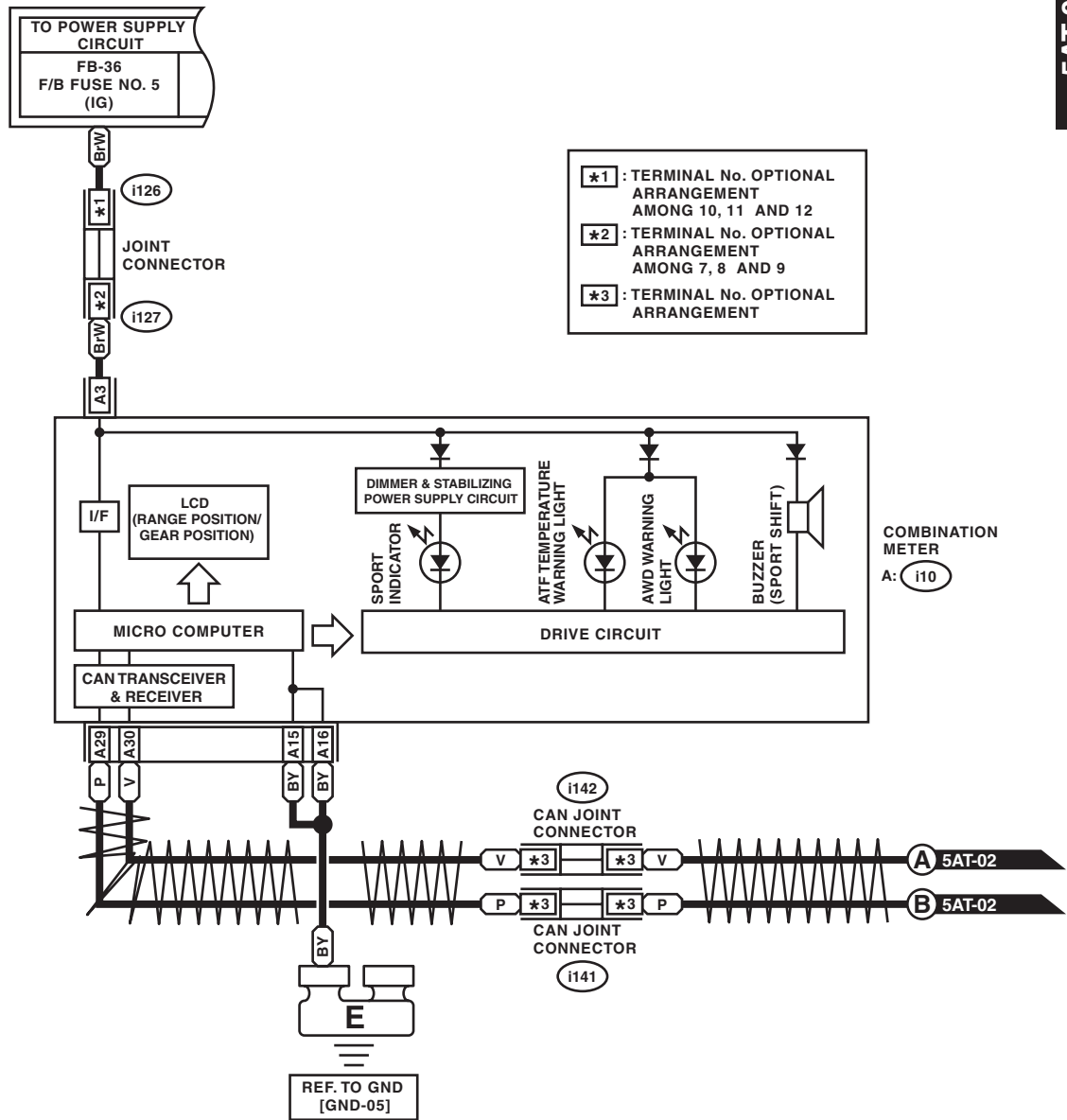

i141
i142

1	2	3	4
---	---	---	---

i126 (BLACK)
i127 (BLACK)

1	2	3	4	5	6
7	8	9	10	11	12

A: i10 (GREEN)

1	2	3	4	5	6	7	8	9	10	11	12	13	14		
15	16	17	18	19	20	21	22	23	24	25	26	27	28	29	30

WI-16006

5AT-02

5AT-02

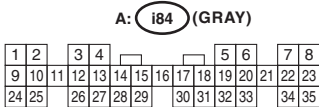
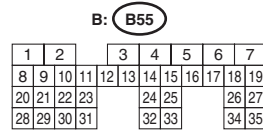
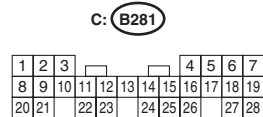
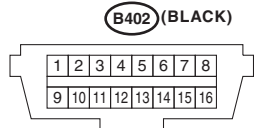
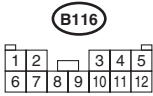
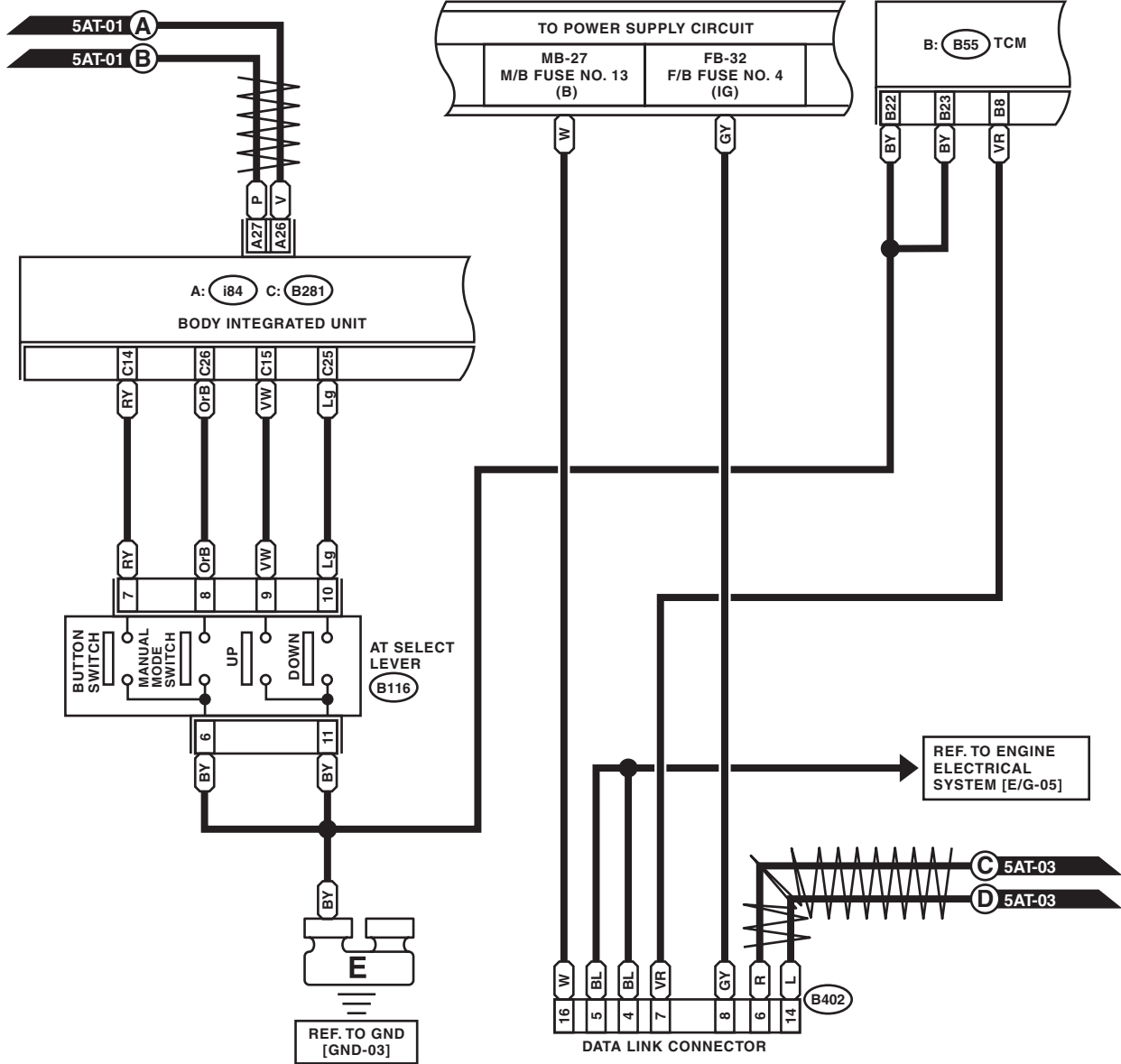

WI-16007

AT Control System

WIRING SYSTEM

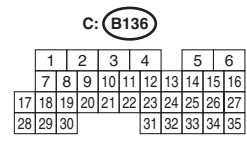
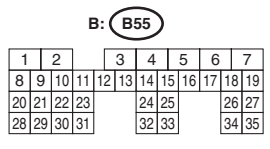
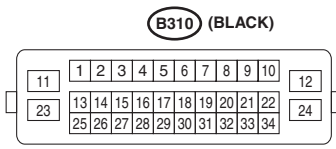
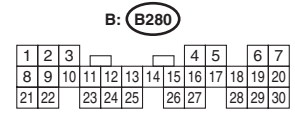
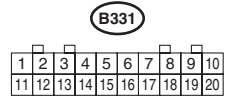
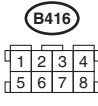
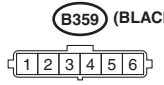
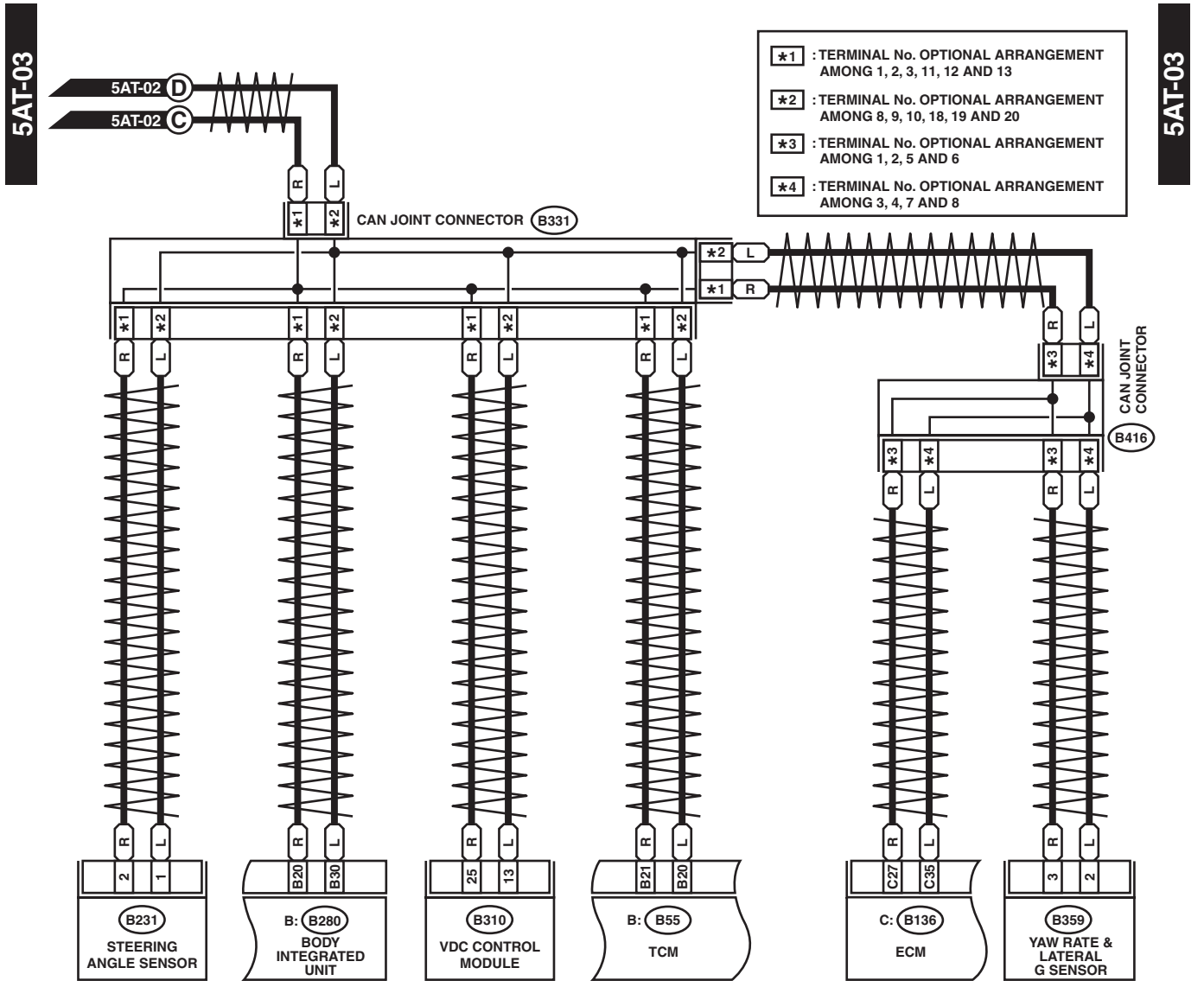

WI-19707

AT Control System

WIRING SYSTEM

5AT-04

5AT-04

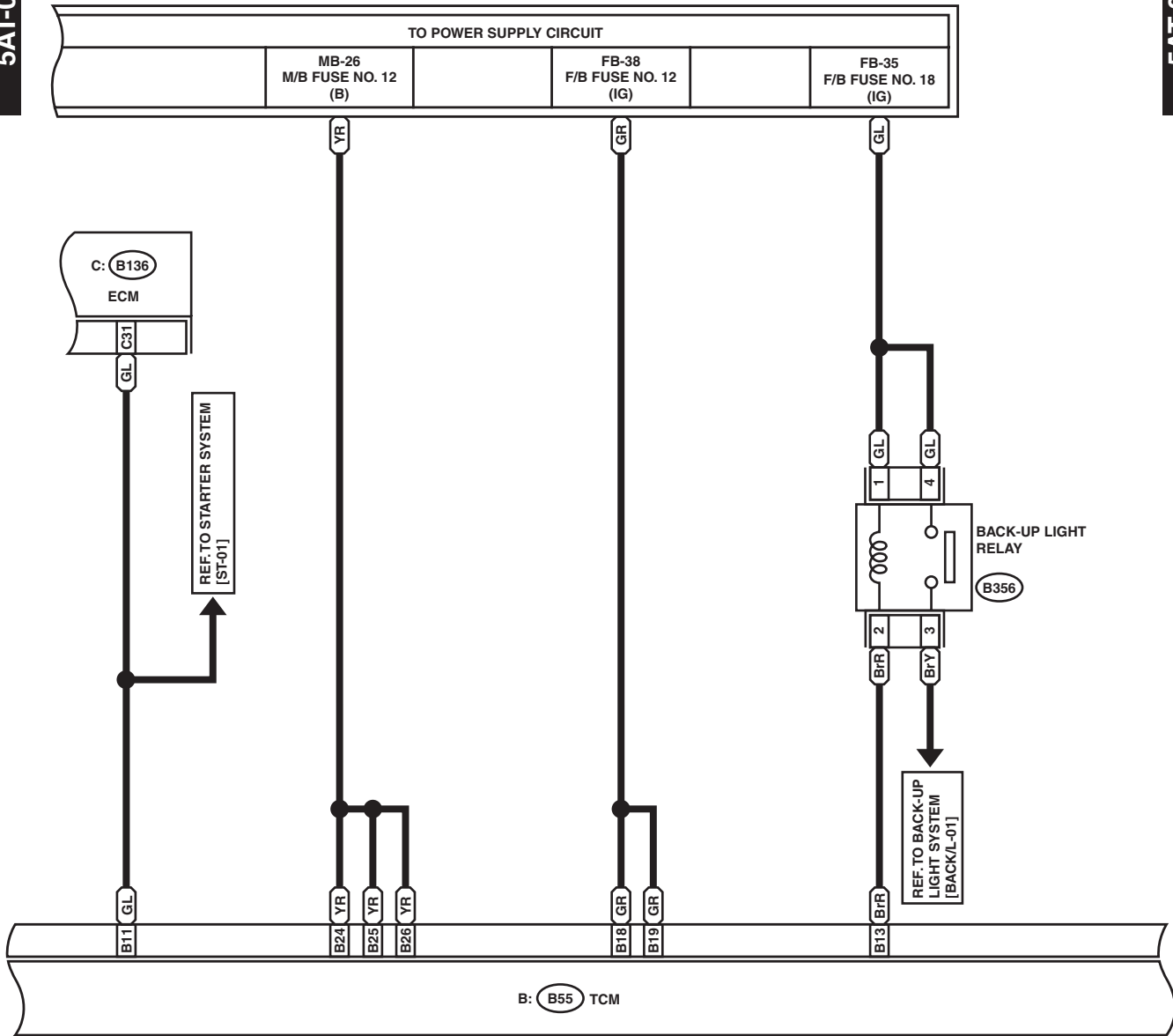

B356 (BLACK)



B: B55

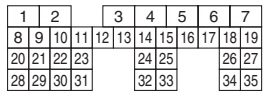

C: B136

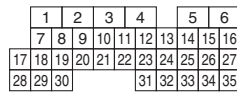

WI-16009

AT Control System

WIRING SYSTEM

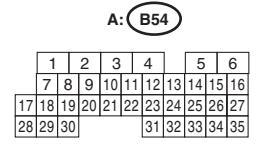
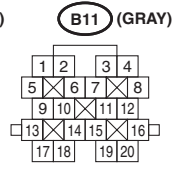
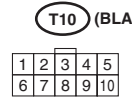
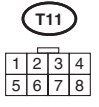
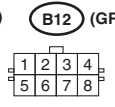
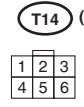
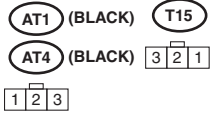
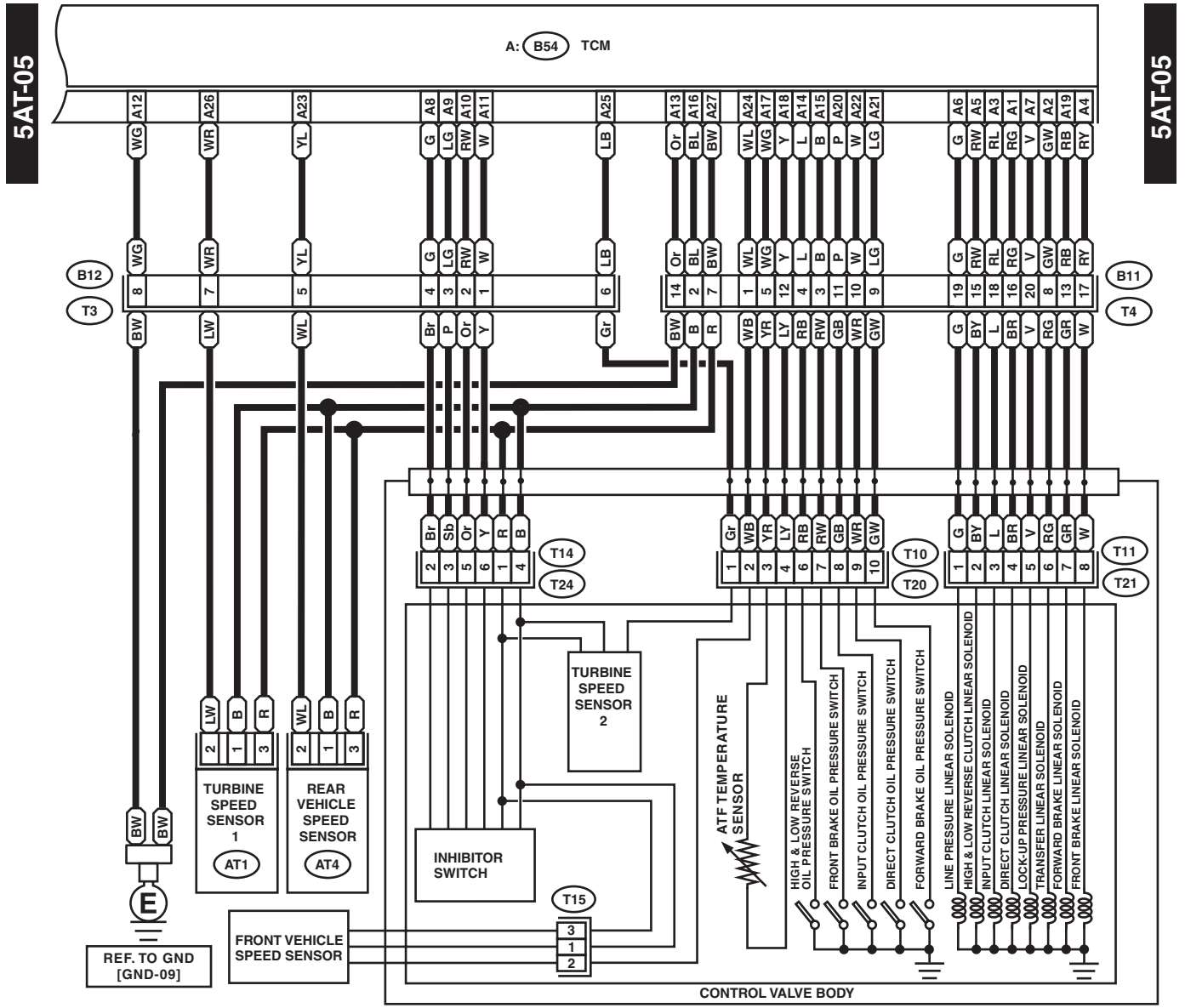

WI-16010