

Leak Check Valve Assembly

EMISSION CONTROL (AUX. EMISSION CONTROL DEVICES)

10. Leak Check Valve Assembly

A: REMOVAL

- 1) Remove the spare tire from the vehicle.
- 2) Disconnect the ground cable from battery.
- 3) Lift up the vehicle.
- 4) Disconnect the drain tube and drain hose from the leak check valve assembly.

NOTE:

Disconnect the quick connector as shown in the figure.

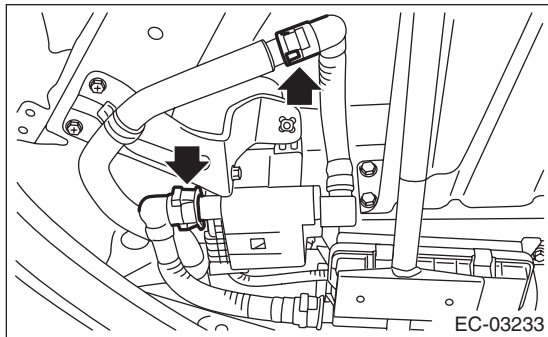
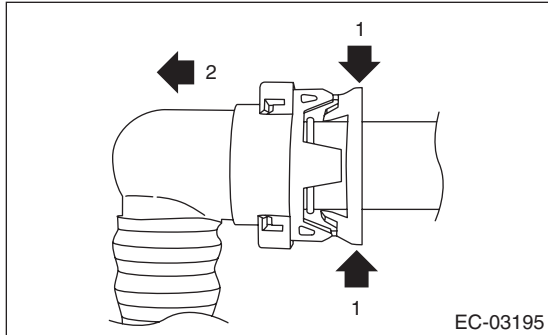

- 5) Disconnect the connector from the leak check valve assembly.

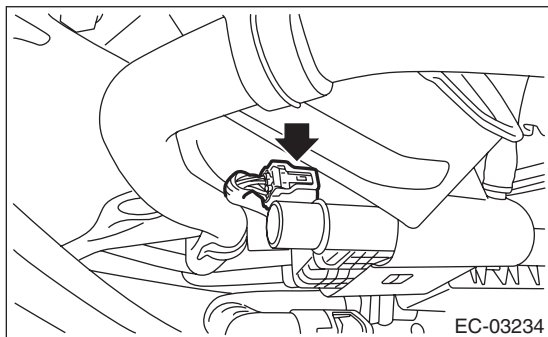

- 6) Disconnect the drain hose from the clip (A) and remove the leak check valve assembly.

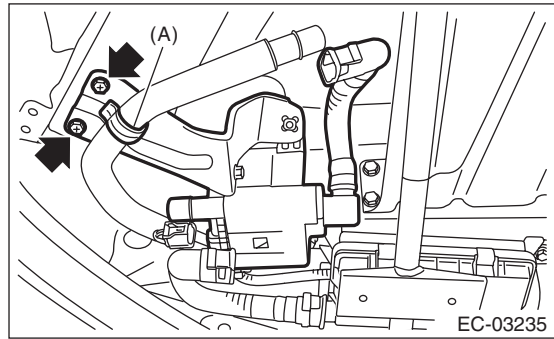

- 7) Remove the bracket from the leak check valve assembly.

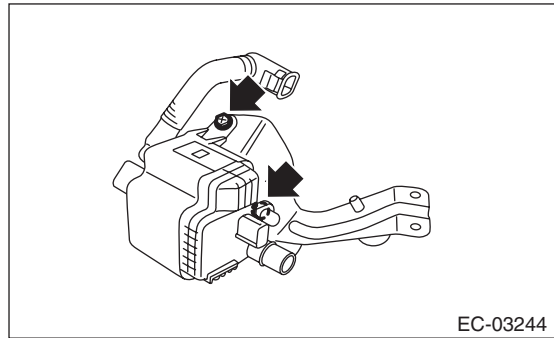

B: INSTALLATION

Install in the reverse order of removal.

CAUTION:

- Make sure there are no damage or dust on connections. If necessary, clean the seal surface of the pipe.
- Make sure that the quick connector is securely connected.

NOTE:

Connect the quick connector as shown in the figure.

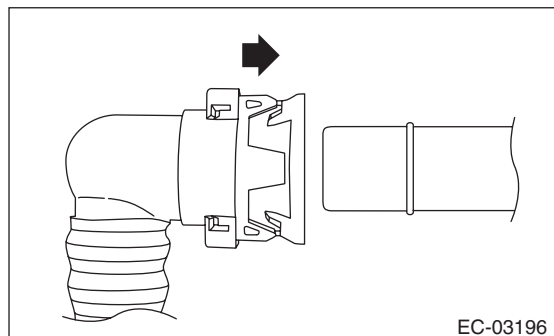

Leak Check Valve Assembly

EMISSION CONTROL (AUX. EMISSION CONTROL DEVICES)

Tightening torque:

5.4 N·m (0.6 kgf-m, 4.0 ft-lb)

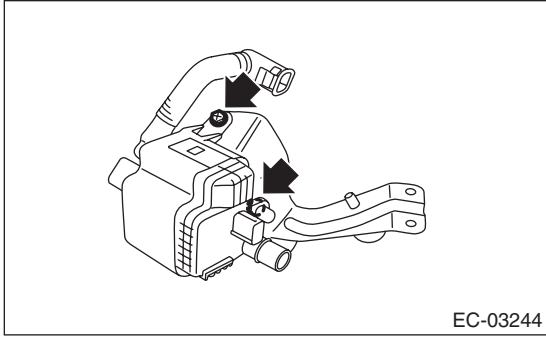

EC-03244

Tightening torque:

7.5 N·m (0.8 kgf-m, 5.5 ft-lb)

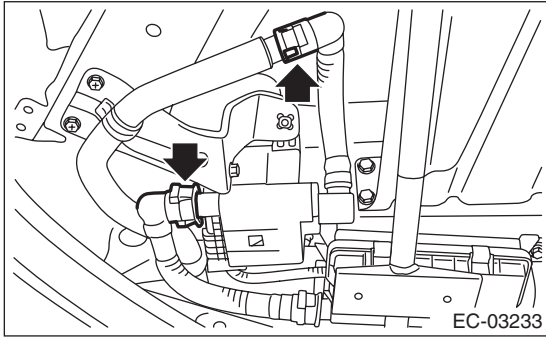

EC-03233

2) Check that air is discharged from (B) when air is blown into (A).

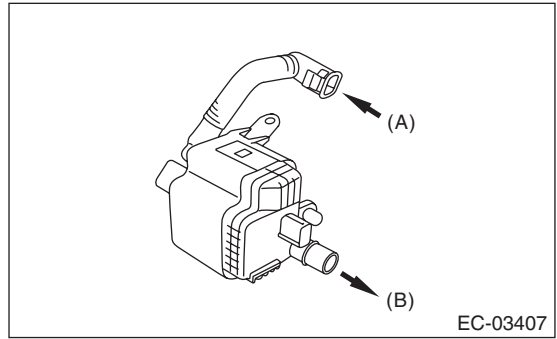

EC-03407

3) Connect the battery positive terminal to the terminal No. 5 and the battery negative terminal to the terminal No. 1. Check that air does not come out from (B) when air is blown into (A).

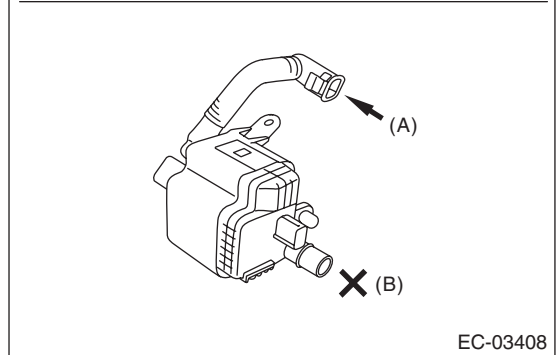
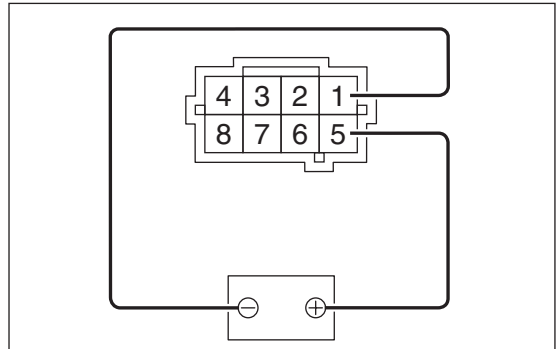

EC-03408

C: INSPECTION

1. CHECK SWITCHING VALVE

1) Check the resistance between switching valve terminals.

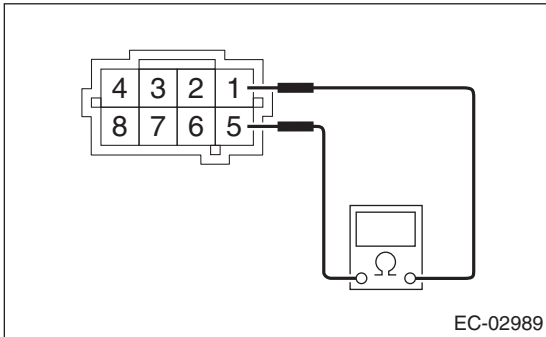

EC-02989

Terminal No.	Standard
1 and 5	$27^{+3}_{-2} \Omega$ (when 20°C (68°F))
	$31 \pm 4 \Omega$ (when 60°C (140°F))

Leak Check Valve Assembly

EMISSION CONTROL (AUX. EMISSION CONTROL DEVICES)

2. CHECK VACUUM PUMP

1) Connect the battery positive terminal to terminal No. 3 and the battery ground terminal to terminal No. 4, and inspect the vacuum pump operation.

CAUTION:

Do not operate the vacuum pump for 5 minutes or more.

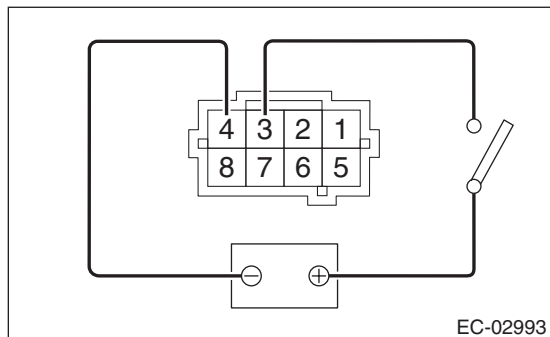

3. CHECK PRESSURE SENSOR

1) Connect dry-cell battery positive terminal to terminal No. 6 and dry-cell battery ground terminal to terminal No. 8, circuit tester positive terminal to terminal No. 7 and the circuit tester negative terminal to terminal No. 8.

NOTE:

- Use new dry-cell batteries.
- Using circuit tester, check the voltage of a single dry-cell battery is 1.6 V or more. And also check the voltage of three batteries in series is between 4.8 V and 5.2 V.

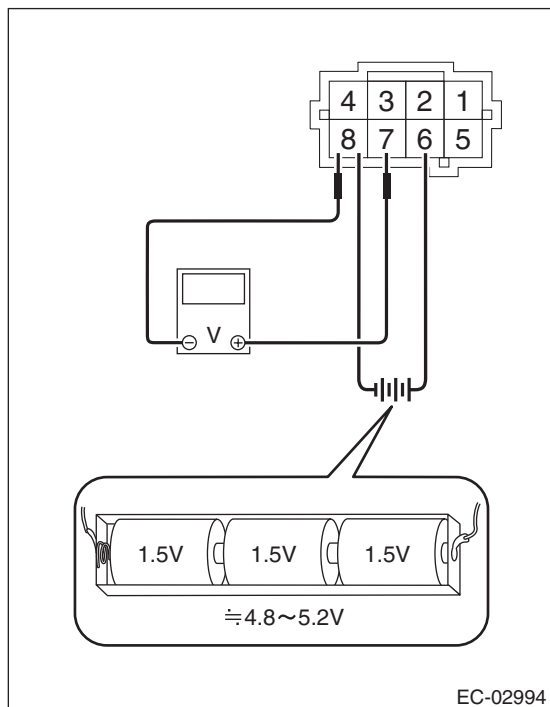

2) Check the voltage at a normal atmospheric pressure.

NOTE:

The atmospheric pressure at higher altitude is lower than normal. Therefore, the voltage is lower than the standard value.

Terminal No.	Standard
7 (+) and 8 (-)	Approx. 3.5 V (when 25°C (77°F))

3) Connect the battery positive terminal to terminal No. 3 and the battery ground terminal to terminal No. 4, and check that there is a voltage drop from the voltage measured in step 2) when the vacuum pump is operated.

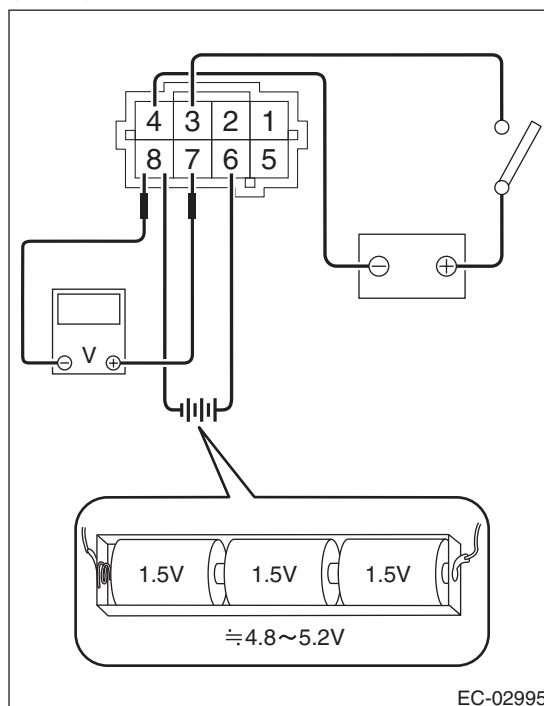

4. OTHER INSPECTIONS

Check that the drain tube has no cracks, damage or loose part.