

12. Drive Cycle

A: PROCEDURE

It is necessary to perform the drive cycle listed below if DTC is not found in the Inspection Mode. It is possible to complete diagnosis of the DTC by performing the indicated drive cycle. After the repair for the DTC, perform a necessary drive cycle and make sure the function recovers and the DTC is recorded.

1. PREPARATION FOR DRIVE CYCLE

- 1) Check that the battery voltage is 12 V or more and fuel remains approx. half [20 — 40 L (5.3 — 10.6 US gal, 4.4 — 8.8 Imp gal)].
- 2) After performing the diagnostics and Clear Memory Mode, check that no DTC remains. <Ref. to EN(H6DO)(diag)-62, Clear Memory Mode.>
- 3) Check the delivery (test) mode connector is disconnected.

NOTE:

- Perform the drive cycle after warming up the engine except when the engine coolant temperature at engine start is specified.
- Perform the drive cycle twice if the DTC in the list is marked with *. After completing the first drive cycle, stop the engine and perform second diagnosis in same condition.

Drive Cycle

ENGINE (DIAGNOSTICS)

2. DRIVE CYCLE A

DTC	Item	Condition
*P0116	Engine Coolant Temperature Sensor 1 Circuit Range/Performance	—
*P0125	Insufficient Coolant Temperature for Closed Loop Fuel Control	Engine coolant temperature at engine start is less than 20°C (68°F).
*P0128	Coolant Thermostat (Engine Coolant Temperature Below Thermostat Regulating Temperature)	—
*P0141	O2 Sensor Heater Circuit (Bank1 Sensor2)	—
*P014C	O2 Sensor Slow Response - Rich to Lean (Bank 1 Sensor 1)	—
*P014D	O2 Sensor Slow Response - Lean to Rich (Bank 1 Sensor 1)	—
*P014E	O2 Sensor Slow Response - Rich to Lean (Bank 2 Sensor 1)	—
*P014F	O2 Sensor Slow Response - Lean to Rich (Bank 2 Sensor 1)	—
*P015A	O2 Sensor Delayed Response - Rich to Lean (Bank 1 Sensor 1)	—
*P015B	O2 Sensor Delayed Response - Lean to Rich (Bank 1 Sensor 1)	—
*P015C	O2 Sensor Delayed Response - Rich to Lean (Bank 2 Sensor 1)	—
*P015D	O2 Sensor Delayed Response - Lean to Rich (Bank 2 Sensor 1)	—
*P0161	O2 Sensor Heater Circuit (Bank2 Sensor2)	—
*P0171	System Too Lean (Bank 1)	Complete diagnosis with drive cycle B or C as well.
*P0172	System Too Rich (Bank 1)	Complete diagnosis with drive cycle B or C as well.
*P0174	System Too Lean (Bank 2)	Complete diagnosis with drive cycle B or C as well.
*P0175	System Too Rich (Bank 2)	Complete diagnosis with drive cycle B or C as well.
*P0196	Engine Oil Temperature Sensor Circuit Range/Performance	—
*P0300	Random/Multiple Cylinder Misfire Detected	Complete diagnosis with drive cycle B or C as well.
*P0301	Cylinder 1 Misfire Detected	Complete diagnosis with drive cycle B or C as well.
*P0302	Cylinder 2 Misfire Detected	Complete diagnosis with drive cycle B or C as well.
*P0303	Cylinder 3 Misfire Detected	Complete diagnosis with drive cycle B or C as well.
*P0304	Cylinder 4 Misfire Detected	Complete diagnosis with drive cycle B or C as well.
*P0305	Cylinder 5 Misfire Detected	Complete diagnosis with drive cycle B or C as well.
*P0306	Cylinder 6 Misfire Detected	Complete diagnosis with drive cycle B or C as well.
*P0420	Catalyst System Efficiency Below Threshold (Bank 1)	—
*P0459	Evaporative Emission System Purge Control Valve Circuit High	—
*P2096	Post Catalyst Fuel Trim System Too Lean (Bank 1)	Complete diagnosis with drive cycle B or C as well.
*P2097	Post Catalyst Fuel Trim System Too Rich (Bank 1)	Complete diagnosis with drive cycle B or C as well.
*P2098	Post Catalyst Fuel Trim System Too Lean Bank 2	Complete diagnosis with drive cycle B or C as well.
*P2099	Post Catalyst Fuel Trim System Too Rich Bank 2	Complete diagnosis with drive cycle B or C as well.

Diagnostic procedure:

- 1) Drive for 20 minutes or more at a constant speed of 80 km/h (50 MPH) or more.
- 2) Stop the vehicle and idle for one minute.

3. DRIVE CYCLE B

DTC	Item	Condition
*P0171	System Too Lean (Bank 1)	Complete diagnosis with drive cycle A or C as well.
*P0172	System Too Rich (Bank 1)	Complete diagnosis with drive cycle A or C as well.
*P0174	System Too Lean (Bank 2)	Complete diagnosis with drive cycle A or C as well.
*P0175	System Too Rich (Bank 2)	Complete diagnosis with drive cycle A or C as well.
*P0300	Random/Multiple Cylinder Misfire Detected	Complete diagnosis with drive cycle A or C as well.
*P0301	Cylinder 1 Misfire Detected	Complete diagnosis with drive cycle A or C as well.
*P0302	Cylinder 2 Misfire Detected	Complete diagnosis with drive cycle A or C as well.
*P0303	Cylinder 3 Misfire Detected	Complete diagnosis with drive cycle A or C as well.
*P0304	Cylinder 4 Misfire Detected	Complete diagnosis with drive cycle A or C as well.
*P0305	Cylinder 5 Misfire Detected	Complete diagnosis with drive cycle A or C as well.
*P0306	Cylinder 6 Misfire Detected	Complete diagnosis with drive cycle A or C as well.
*P0506	Idle Air Control System RPM Lower Than Expected	—
*P0507	Idle Air Control System RPM Higher Than Expected	—
*P2096	Post Catalyst Fuel Trim System Too Lean (Bank 1)	Complete diagnosis with drive cycle A or C as well.
*P2097	Post Catalyst Fuel Trim System Too Rich (Bank 1)	Complete diagnosis with drive cycle A or C as well.
*P2098	Post Catalyst Fuel Trim System Too Lean Bank 2	Complete diagnosis with drive cycle A or C as well.
*P2099	Post Catalyst Fuel Trim System Too Rich Bank 2	Complete diagnosis with drive cycle A or C as well.
*P219A	Bank 1 Air-Fuel Ratio Imbalance	Complete diagnosis with drive cycle C as well.
*P219B	Bank 2 Air-Fuel Ratio Imbalance	Complete diagnosis with drive cycle C as well.

Diagnostic procedure:

- 1) Drive at 10 km/h (6 MPH) or more.
- 2) Stop the vehicle and idle for ten minutes.

Drive Cycle

ENGINE (DIAGNOSTICS)

4. DRIVE CYCLE C

DTC	Item	Condition
*P0030	HO2S Heater Control Circuit (Bank 1 Sensor 1)	—
*P0050	HO2S Heater Control Circuit (Bank 2 Sensor 1)	—
*P0068	MAP/MAF - Throttle Position Correlation	—
*P0101	Mass or Volume Air Flow Circuit Range/Performance	—
P0134	O2 Sensor Circuit No Activity Detected (Bank 1 Sensor 1)	—
*P013A	O2 Sensor Slow Response - Rich to Lean (Bank 1 Sensor 2)	—
*P013B	O2 Sensor Slow Response - Lean to Rich (Bank 1 Sensor 2)	—
*P013C	O2 Sensor Slow Response - Rich to Lean (Bank 2 Sensor 2)	—
*P013D	O2 Sensor Slow Response - Lean to Rich (Bank 2 Sensor 2)	—
*P013E	O2 Sensor Delayed Response - Rich to Lean (Bank 1 Sensor 2)	—
*P013F	O2 Sensor Delayed Response - Lean to Rich (Bank 1 Sensor 2)	—
*P014A	O2 Sensor Delayed Response - Rich to Lean (Bank 2 Sensor 2)	—
*P014B	O2 Sensor Delayed Response - Lean to Rich (Bank 2 Sensor 2)	—
P0154	O2 Sensor Circuit No Activity Detected (Bank 2 Sensor 1)	—
*P0171	System Too Lean (Bank 1)	Complete diagnosis with drive cycle A or B as well.
*P0172	System Too Rich (Bank 1)	Complete diagnosis with drive cycle A or B as well.
*P0174	System Too Lean (Bank 2)	Complete diagnosis with drive cycle A or B as well.
*P0175	System Too Rich (Bank 2)	Complete diagnosis with drive cycle A or B as well.
*P0300	Random/Multiple Cylinder Misfire Detected	Complete diagnosis with drive cycle A or B as well.
*P0301	Cylinder 1 Misfire Detected	Complete diagnosis with drive cycle A or B as well.
*P0302	Cylinder 2 Misfire Detected	Complete diagnosis with drive cycle A or B as well.
*P0303	Cylinder 3 Misfire Detected	Complete diagnosis with drive cycle A or B as well.
*P0304	Cylinder 4 Misfire Detected	Complete diagnosis with drive cycle A or B as well.
*P0305	Cylinder 5 Misfire Detected	Complete diagnosis with drive cycle A or B as well.
*P0306	Cylinder 6 Misfire Detected	Complete diagnosis with drive cycle A or B as well.
*P0400	Exhaust Gas Recirculation Flow	—
*P0441	Evaporative Emission Cont. Sys. Incorrect Purge Flow	—
*P1449	Evaporative Emission Cont. Sys. Air Filter Clog	—
P1492	EGR Solenoid Valve Signal #1 Circuit Malfunction (Low Input)	—
P1493	EGR Solenoid Valve Signal #1 Circuit Malfunction (High Input)	—
P1494	EGR Solenoid Valve Signal #2 Circuit Malfunction (Low Input)	—
P1495	EGR Solenoid Valve Signal #2 Circuit Malfunction (High Input)	—
P1496	EGR Solenoid Valve Signal #3 Circuit Malfunction (Low Input)	—
P1497	EGR Solenoid Valve Signal #3 Circuit Malfunction (High Input)	—
P1498	EGR Solenoid Valve Signal #4 Circuit Malfunction (Low Input)	—
P1499	EGR Solenoid Valve Signal #4 Circuit Malfunction (High Input)	—
*P2096	Post Catalyst Fuel Trim System Too Lean (Bank 1)	Complete diagnosis with drive cycle A or B as well.
*P2097	Post Catalyst Fuel Trim System Too Rich (Bank 1)	Complete diagnosis with drive cycle A or B as well.
*P2098	Post Catalyst Fuel Trim System Too Lean Bank 2	Complete diagnosis with drive cycle A or B as well.
*P2099	Post Catalyst Fuel Trim System Too Rich Bank 2	Complete diagnosis with drive cycle A or B as well.
*P219A	Bank 1 Air-Fuel Ratio Imbalance	Complete diagnosis with drive cycle B as well.
*P219B	Bank 2 Air-Fuel Ratio Imbalance	Complete diagnosis with drive cycle B as well.

Diagnostic procedure:

Drive according to the drive pattern described below.

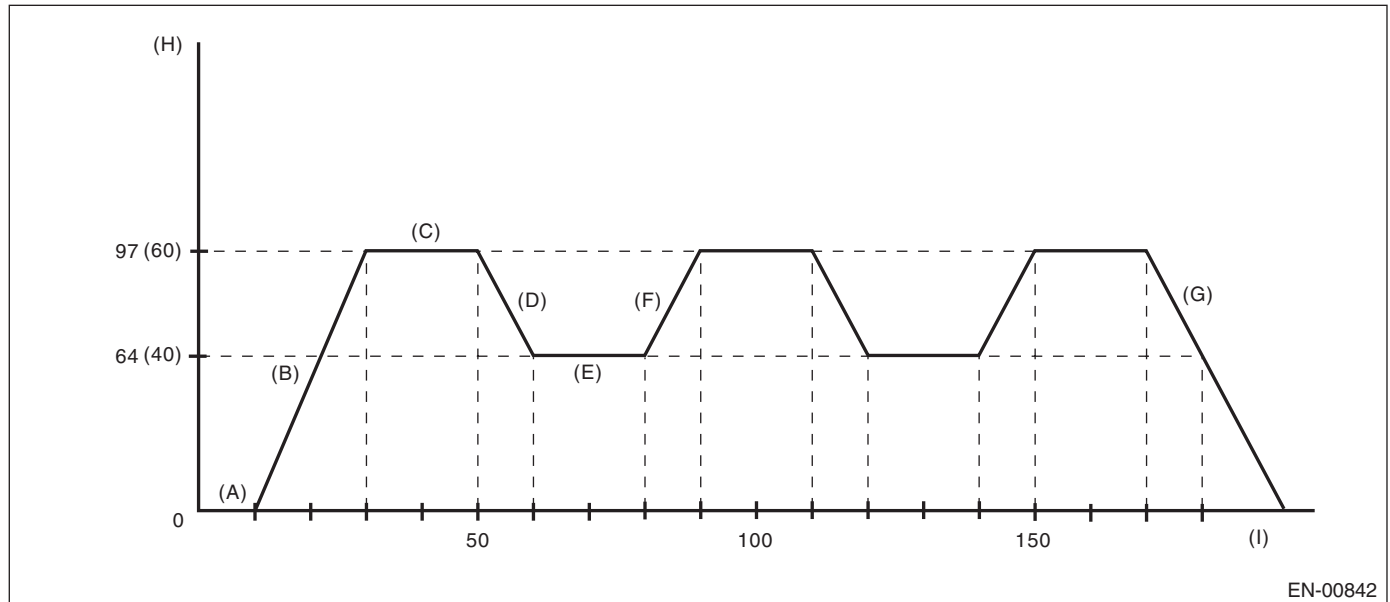

EN-00842

- | | | |
|---|--|--|
| (A) Idle the engine for 10 seconds or more. | (D) Decelerate with fully closed throttle to 64 km/h (40 MPH) or less. | (G) Stop the vehicle with throttle fully closed. |
| (B) Accelerate to 97 km/h (60 MPH) or more within 20 seconds. | (E) Drive for 20 seconds or more at 64 km/h (40 MPH) or less. | (H) Vehicle speed km/h (MPH) |
| (C) Drive for 20 seconds or more at 97 km/h (60 MPH) or more. | (F) Accelerate to 97 km/h (60 MPH) or more within 10 seconds. | (I) Sec. |

5. DRIVE CYCLE E

DTC	Item	Condition
*P0461	Fuel Level Sensor "A" Circuit Range/Performance	—

Diagnostic procedure:

- 1) Make sure that the battery voltage is 10.9 V or more.
- 2) Perform the Clear Memory Mode. <Ref. to EN(H6DO)(diag)-62, Clear Memory Mode.>
- 3) Drive for approximately 30 L (7.9 US gal, 6.6 Imp gal) of fuel.

NOTE:

- It is acceptable to drive the vehicle intermittently.
- Do not disconnect the battery terminals while diagnosing. (Data will be cleared by disconnecting the battery terminals.)

Drive Cycle

ENGINE (DIAGNOSTICS)

6. DRIVE CYCLE F

DTC	Item	Condition
*P0111	Intake Air Temperature Sensor Range/Performance Problem	—

Diagnostic procedure:

- 1) Make sure that the engine coolant temperature is less than 30°C (86°F).
- 2) Drive according to the drive pattern described below.

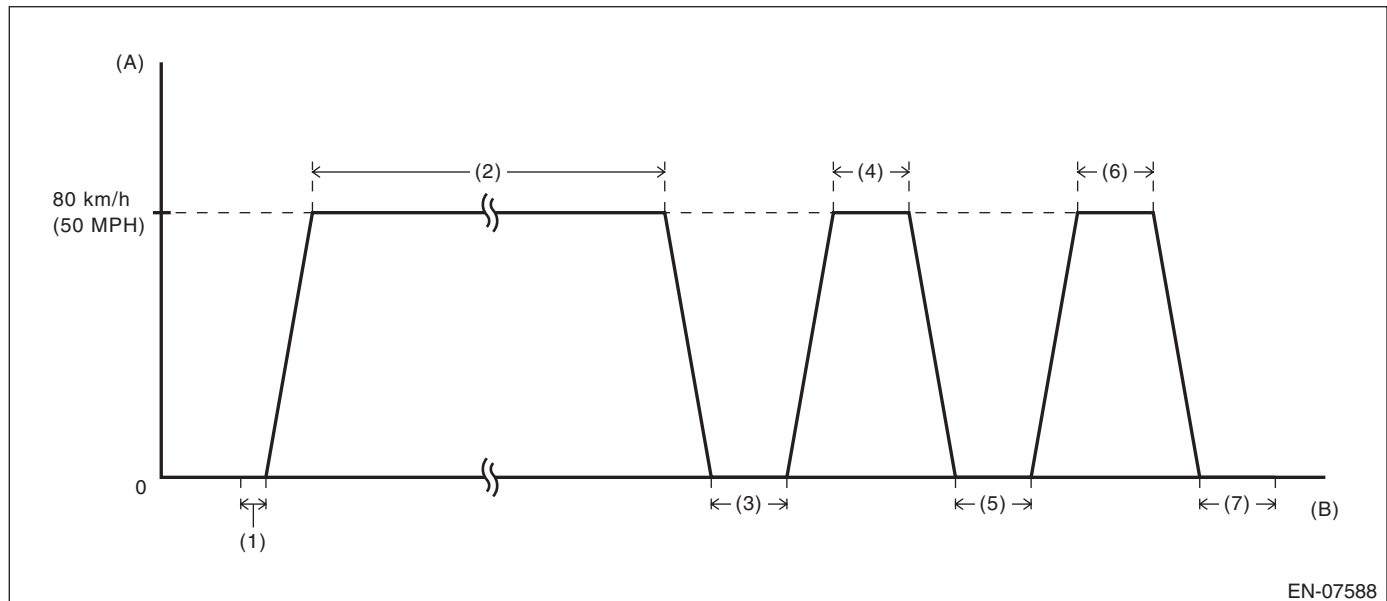

(A) Vehicle speed

(B) Elapsed time

- | | | |
|--|---|---|
| <p>(1) Idle the engine for 10 seconds or more after engine start.</p> <p>(2) Drive for 8 minutes or more at a constant speed of 80 km/h (50 MPH) or more.</p> <p>(3) Stop the vehicle and idle for 30 seconds or more.</p> | <p>(4) Drive for 30 seconds or more at a constant speed of 80 km/h (50 MPH) or more.</p> <p>(5) Stop the vehicle and idle for 30 seconds or more.</p> | <p>(6) Drive for 30 seconds or more at a constant speed of 80 km/h (50 MPH) or more.</p> <p>(7) Stop the vehicle and idle for 30 seconds.</p> |
|--|---|---|

NOTE:

- There is no given transition time between idling and cruising.
- Driving at constant speed only on a downhill causes smaller engine load and may result in failure to obtain a right diagnostic result.
- When the engine stops while performing drive cycle F, perform it again from the state of procedure 1).

7. DRIVE CYCLE H

DTC	Item	Condition
*P050A	Cold Start Idle Air Control System Performance	—
*P050B	Cold Start Ignition Timing Performance	—

Diagnostic procedure:

- 1) Perform the Clear Memory Mode. <Ref. to EN(H6DO)(diag)-62, Clear Memory Mode.>
- 2) With the ignition switch ON (engine stopped), read the value in «Coolant Temp.» and «Intake Air Temp.».
<Ref. to EN(H6DO)(diag)-38, READ CURRENT DATA FOR ENGINE (NORMAL MODE), OPERATION, Subaru Select Monitor.>
- 3) If the values from step 2) satisfy the following conditions, idle the engine for one minute.

Condition:

$$|\text{Engine coolant temperature} - \text{Intake air temperature}| \leq 5^{\circ}\text{C} (9^{\circ}\text{F})$$

NOTE:

- If the conditions are not satisfied, turn the ignition switch to OFF and wait until the parameters are satisfied.
- Hold the select lever in “P” range or “N” range at idling.

8. DRIVE CYCLE I

DTC	Item	Condition
*P0455	Evaporative Emission System Leak Detected (Large Leak)	«Coolant Temp.»: 5 — 45°C (41 — 113°F) «Intake Air Temp.»: 5 — 50°C (41 — 122°F)
*P0456	Evaporative Emission Control System Leak Detected (Very Small Leak)	
*P1451	Evaporative Emission Cont. Sys.	
*P2402	Evaporative Emission System Leak Detection Pump Control Circuit High	
*P2404	Evaporative Emission System Leak Detection Pump Sense Circuit Range/Performance	
*P2420	Evaporative Emission System Switching Valve Control Circuit High	

CAUTION:

Be careful of the state of the battery when performing the drive cycle I consecutively. Performing the drive cycle I consecutively without the engine running may cause a low battery voltage and battery discharge.

NOTE:

- If it is necessary to perform drive cycle I consecutively, drive the vehicle under the following conditions to release accumulated evaporating gas. Performing the drive cycle I consecutively without starting the engine causes a large amount of evaporating gas to accumulate in the canister, which hinders an accurate diagnosis.
 - After engine is warmed up
 - Drive for 10 minutes or more at a speed of 48 km/h (30 MPH) or more (duration of drive can be an accumulation)
- To obtain an accurate diagnostic result, perform the procedures according to the following points.
 - Do not refuel gas immediately before performing drive cycle I. There will be a large amount of evaporating gas immediately after refuel, which may cause a less accurate diagnostic performance.
 - Do not shake the vehicle while performing drive cycle I. Shaking the vehicle causes evaporating gas to increase inside the fuel tank, which may cause a less accurate diagnostic performance.
 - Do not perform any service operation including installation or removal of parts or connectors while performing drive cycle I. Performing service operation could affect on the functions of related parts, which may cause a less accurate diagnostic performance.

Drive Cycle

ENGINE (DIAGNOSTICS)

Diagnostic procedure:

1) Prepare the Subaru Select Monitor kit. <Ref. to EN(H6DO)(diag)-8, PREPARATION TOOL, General Description.>

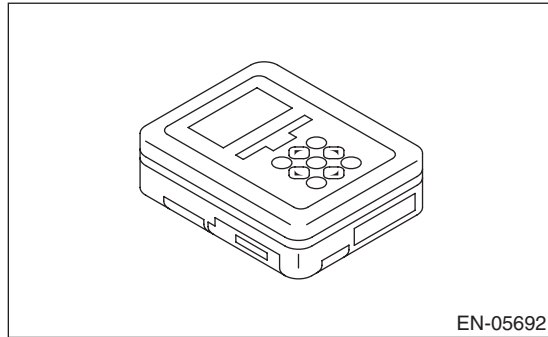

2) Prepare PC with Subaru Select Monitor installed.

3) Connect the USB cable to SDI (Subaru Diagnosis Interface) and USB port on the personal computer (dedicated port for the Subaru Select Monitor).

NOTE:

The dedicated port for the Subaru Select Monitor means the USB port which was used to install the Subaru Select Monitor.

4) Connect the diagnosis cable to SDI.

5) Connect SDI to data link connector located in the lower portion of the instrument panel (on the driver's side).

CAUTION:

Do not connect the scan tools except for Subaru Select Monitor and general scan tool.

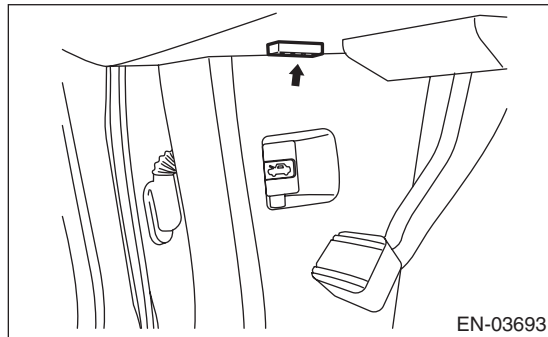

6) Start the PC.

7) Turn the ignition switch to ON (engine OFF) and run the "PC application for Subaru Select Monitor".

8) On «Main Menu» display, select {Each System Check}.

9) On «System Selection Menu» display, select {Engine Control System}.

10) Click the [OK] button after the information of engine type has been displayed.

11) On «Engine Diagnosis» display, select {OBD System}.

12) On «OBD Menu» display, select {Evaporative System Leak Test}.

13) On «Evaporative System Leak Test» display, select {Evaporative System Leak Test}.

14) On «Evaporative System Leak Test is running. Press Cancel to exit this function.» display, click the [OK] button to perform evaporative system leak test.

15) When «Conditions have been enabled to control this function. Turn the ignition switch off to terminate the test.» display appears, wait for 30 minutes without clicking the [OK] button.

CAUTION:

Do not leave the vehicle for an extended period of time after the test is complete. This may cause early deterioration of the battery or discharged battery.

NOTE:

- Clicking the [OK] button bring the «Evaporative System Leak Test» display back, although the test is continuing.
- The Subaru Select Monitor screen does not change after the evaporative system leak test is complete or when the test is aborted by turning off the ignition switch.
- If «Test conditions are not correct» display appears, check that the values in «Coolant Temp.» and «Intake Air Temp.» are within the specified range using Subaru Select Monitor. If the conditions are satisfied, make the necessary preparation for the drive cycle again. <Ref. to EN(H6DO)(diag)-53, PREPARATION FOR DRIVE CYCLE, PROCEDURE, Drive Cycle.>

16) After 30 minutes passed from the start of step 14), click the [OK] button to return to the «Evaporative System Leak Test» display.

17) Click buttons until the «OBD Menu» display appears, then select {Result of on-board monitor test}.

18) In the {Result of on-board monitor test}, check TID \$C1 — \$CA of MID \$3C.

Result of on-board monitor test

Display	Details	Remarks
\$0000 is stored in all Val.	During the evaporative system leak test, the test conditions were not met and the test was canceled.	Once the test conditions are met, perform the test again.
All Val. are stored with values and OK is set to all the results.	Evaporative system leak test is completed correctly.	While the ignition switch is ON, read the pending code using the Subaru Select Monitor.
Some results were no good.	The evaporative system leak test completed successfully but the results were faulty.	While the ignition switch is ON, read the pending code using the Subaru Select Monitor.

19) When the evaporative system leak test is completed correctly, read the pending code with the ignition switch turned to ON position. If the DTC is recorded, check the appropriate DTC. <Ref. to EN(H6DO)(diag)-46, OPERATION, Read Diagnostic Trouble Code (DTC).>

NOTE:

The pending code will be cleared by turning ignition switch to OFF.

9. DRIVE CYCLE J

DTC	Item	Condition
P2610	ECM/PCM Internal Engine Off Timer Performance	—

Diagnostic procedure:

- 1) Idle the engine for 15 minutes or more.
- 2) Turn the ignition switch to OFF.
- 3) After 10 hours passed from the start of step 2), read the pending code using the Subaru Select Monitor. <Ref. to EN(H6DO)(diag)-46, OPERATION, Read Diagnostic Trouble Code (DTC).>