

# Diagnostic Procedure with Diagnostic Trouble Code (DTC)

ENGINE (DIAGNOSTICS)

## 20. Diagnostic Procedure with Diagnostic Trouble Code (DTC)

### A: DTC P0011 INTAKE CAMSHAFT POSITION - TIMING OVER-ADVANCED OR SYSTEM PERFORMANCE (BANK 1)

#### DTC DETECTING CONDITION:

- Detected when two consecutive driving cycles with fault occur.
- GENERAL DESCRIPTION <Ref. to GD(H6DO)-11, DTC P0011 INTAKE CAMSHAFT POSITION - TIMING OVER-ADVANCED OR SYSTEM PERFORMANCE (BANK 1), Diagnostic Trouble Code (DTC) Detecting Criteria.>

#### TROUBLE SYMPTOM:

- Engine stalls.
- Improper idling

#### CAUTION:

After servicing or replacing faulty parts, perform Clear Memory Mode <Ref. to EN(H6DO)(diag)-62, OPERATION, Clear Memory Mode.>, and Inspection Mode <Ref. to EN(H6DO)(diag)-47, PROCEDURE, Inspection Mode.>.

Step	Check	Yes	No
<p><b>1</b></p> <p><b>CHECK CURRENT DATA.</b> 1) Start the engine and let it idle. 2) Read the value of «VVT Adv. Ang. Amount R» using the Subaru Select Monitor. NOTE: For detailed operation procedures, refer to “READ CURRENT DATA FOR ENGINE”. &lt;Ref. to EN(H6DO)(diag)-37, Subaru Select Monitor.&gt;</p>	<p>Is the value of «VVT Adv. Ang. Amount R» approx. 0 deg?</p>	<p>Go to step 2.</p>	<p>Check the following item and repair or replace if necessary.</p> <ul style="list-style-type: none"> <li>• Oil pipe (clog)</li> <li>• Oil flow control solenoid valve (clog or dirt of oil routing, setting of spring)</li> <li>• Intake camshaft (dirt, damage of camshaft)</li> </ul>
<p><b>2</b></p> <p><b>CHECK CURRENT DATA.</b> 1) Drive with acceleration and deceleration at 80 km/h (50 MPH) or less. NOTE: Drive to an extent that the duty output of oil flow control solenoid valve increases. 2) Read the values of «OCV Duty R» and «VVT Adv. Ang. Amount R» using the Subaru Select Monitor. NOTE: For detailed operation procedures, refer to “READ CURRENT DATA FOR ENGINE”. &lt;Ref. to EN(H6DO)(diag)-37, Subaru Select Monitor.&gt;</p>	<p>When the value of «OCV Duty R» increases more than 10%, is the value of «VVT Adv. Ang. Amount R» approx. 0 deg?</p>	<p>Check the following item and repair or replace if necessary.</p> <ul style="list-style-type: none"> <li>• Oil pipe (clog)</li> <li>• Oil flow control solenoid valve (clog or dirt of oil routing, setting of spring)</li> <li>• Intake camshaft (dirt, damage of camshaft)</li> </ul>	<p>Perform the following procedures, and clean the oil routing. Replace the engine oil and idle the engine for 5 minutes, and then replace the oil filter and engine oil. &lt;Ref. to LU(H6DO)-10, REPLACEMENT, Engine Oil.&gt; &lt;Ref. to LU(H6DO)-16, Engine Oil Filter.&gt;</p>

# Diagnostic Procedure with Diagnostic Trouble Code (DTC)

ENGINE (DIAGNOSTICS)

## B: DTC P0014 EXHAUST AVCS SYSTEM 1 (RANGE/PERFORMANCE)

### DTC DETECTING CONDITION:

- Detected when two consecutive driving cycles with fault occur.
- GENERAL DESCRIPTION <Ref. to GD(H6DO)-13, DTC P0014 EXHAUST AVCS SYSTEM 1 (RANGE/PERFORMANCE), Diagnostic Trouble Code (DTC) Detecting Criteria.>

### TROUBLE SYMPTOM:

- Engine stalls.
- Improper idling

### CAUTION:

After servicing or replacing faulty parts, perform Clear Memory Mode <Ref. to EN(H6DO)(diag)-62, OPERATION, Clear Memory Mode.>, and Inspection Mode <Ref. to EN(H6DO)(diag)-47, PROCEDURE, Inspection Mode.>.

Step	Check	Yes	No
<p><b>1</b></p> <p><b>CHECK CURRENT DATA.</b></p> <p>1) Start the engine and let it idle.</p> <p>2) Read the value of «Exh. VVT Retard Ang. R» using the Subaru Select Monitor.</p> <p>NOTE: For detailed operation procedures, refer to “READ CURRENT DATA FOR ENGINE”. &lt;Ref. to EN(H6DO)(diag)-37, Subaru Select Monitor.&gt;</p>	<p>Is the value of «Exh. VVT Retard Ang. R» approx. 0 deg?</p>	<p>Go to step 2.</p>	<p>Check the following item and repair or replace if necessary.</p> <ul style="list-style-type: none"> <li>• Oil pipe (clog)</li> <li>• Oil flow control solenoid valve (clog or dirt of oil routing, setting of spring)</li> <li>• Exhaust camshaft (dirt, damage of camshaft)</li> </ul>
<p><b>2</b></p> <p><b>CHECK CURRENT DATA.</b></p> <p>1) Drive with acceleration and deceleration at 80 km/h (50 MPH) or less.</p> <p>NOTE: Drive to an extent that the duty output of oil flow control solenoid valve increases.</p> <p>2) Read the values of «Exh. OCV Duty R» and «Exh. VVT Retard Ang. R» using the Subaru Select Monitor.</p> <p>NOTE: For detailed operation procedures, refer to “READ CURRENT DATA FOR ENGINE”. &lt;Ref. to EN(H6DO)(diag)-37, Subaru Select Monitor.&gt;</p>	<p>When the value of «Exh. OCV Duty R» increases more than 10%, is the value of «Exh. VVT Retard Ang. R» approx. 0 deg?</p>	<p>Check the following item and repair or replace if necessary.</p> <ul style="list-style-type: none"> <li>• Oil pipe (clog)</li> <li>• Oil flow control solenoid valve (clog or dirt of oil routing, setting of spring)</li> <li>• Exhaust camshaft (dirt, damage of camshaft)</li> </ul>	<p>Perform the following procedures, and clean the oil routing.</p> <p>Replace the engine oil and idle the engine for 5 minutes, and then replace the oil filter and engine oil.</p> <p>&lt;Ref. to LU(H6DO)-10, REPLACEMENT, Engine Oil.&gt; &lt;Ref. to LU(H6DO)-16, Engine Oil Filter.&gt;</p>

# Diagnostic Procedure with Diagnostic Trouble Code (DTC)

ENGINE (DIAGNOSTICS)

## C: DTC P0016 CRANKSHAFT POSITION - CAMSHAFT POSITION CORRELATION (BANK1)

### DTC DETECTING CONDITION:

- Detected when two consecutive driving cycles with fault occur.
- GENERAL DESCRIPTION <Ref. to GD(H6DO)-15, DTC P0016 CRANKSHAFT POSITION - CAMSHAFT POSITION CORRELATION (BANK1), Diagnostic Trouble Code (DTC) Detecting Criteria.>

### TROUBLE SYMPTOM:

- Engine stalls.
- Improper idling

### CAUTION:

After servicing or replacing faulty parts, perform Clear Memory Mode <Ref. to EN(H6DO)(diag)-62, OPERATION, Clear Memory Mode.>, and Inspection Mode <Ref. to EN(H6DO)(diag)-47, PROCEDURE, Inspection Mode.>.

	Step	Check	Yes	No
1	<b>CHECK CURRENT DATA.</b> 1) Start the engine and let it idle. 2) Read the values of «VVT Adv. Ang. Amount R» and «OCV Duty R» using the Subaru Select Monitor.  NOTE: For detailed operation procedures, refer to “READ CURRENT DATA FOR ENGINE”. <Ref. to EN(H6DO)(diag)-37, Subaru Select Monitor.>	Is the value of «VVT Adv. Ang. Amount R» approx. 0 deg, and the value of «OCV Duty R» approx. 10%?	Perform the following procedures, and clean the oil routing. Replace the engine oil and idle the engine for 5 minutes, and then replace the oil filter and engine oil. <Ref. to LU(H6DO)-10, REPLACEMENT, Engine Oil.> <Ref. to LU(H6DO)-16, Engine Oil Filter.>	Check the following item and repair or replace if necessary. <ul style="list-style-type: none"><li>• Oil pipe (clog)</li><li>• Oil flow control solenoid valve (clog or dirt of oil routing, setting of spring)</li><li>• Intake camshaft (dirt, damage of camshaft)</li><li>• Timing chain (matching of timing mark)</li></ul>

# Diagnostic Procedure with Diagnostic Trouble Code (DTC)

ENGINE (DIAGNOSTICS)

## D: DTC P0017 CRANK AND CAM TIMING B SYSTEM FAILURE (BANK 1)

### DTC DETECTING CONDITION:

- Detected when two consecutive driving cycles with fault occur.
- GENERAL DESCRIPTION <Ref. to GD(H6DO)-17, DTC P0017 CRANK AND CAM TIMING B SYSTEM FAILURE (BANK 1), Diagnostic Trouble Code (DTC) Detecting Criteria.>

### TROUBLE SYMPTOM:

- Engine stalls.
- Improper idling

### CAUTION:

After servicing or replacing faulty parts, perform Clear Memory Mode <Ref. to EN(H6DO)(diag)-62, OPERATION, Clear Memory Mode.>, and Inspection Mode <Ref. to EN(H6DO)(diag)-47, PROCEDURE, Inspection Mode.>.

Step	Check	Yes	No
<p><b>1</b></p> <p><b>CHECK CURRENT DATA.</b></p> <p>1) Start the engine and let it idle.</p> <p>2) Read the values of «Exh. VVT Retard Ang. R» and «Exh. OCV Duty R» using the Subaru Select Monitor.</p> <p>NOTE: For detailed operation procedures, refer to "READ CURRENT DATA FOR ENGINE". &lt;Ref. to EN(H6DO)(diag)-37, Subaru Select Monitor.&gt;</p>	<p>Is the value of «Exh. VVT Retard Ang. R» approx. 0 deg, and the value of «Exh. OCV Duty R» approx. 10%?</p>	<p>Perform the following procedures, and clean the oil routing.</p> <p>Replace the engine oil and idle the engine for 5 minutes, and then replace the oil filter and engine oil.</p> <p>&lt;Ref. to LU(H6DO)-10, REPLACEMENT, Engine Oil.&gt; &lt;Ref. to LU(H6DO)-16, Engine Oil Filter.&gt;</p>	<p>Check the following item and repair or replace if necessary.</p> <ul style="list-style-type: none"> <li>• Oil pipe (clog)</li> <li>• Oil flow control solenoid valve (clog or dirt of oil routing, setting of spring)</li> <li>• Exhaust camshaft (dirt, damage of camshaft)</li> <li>• Timing chain (matching of timing mark)</li> </ul>

# Diagnostic Procedure with Diagnostic Trouble Code (DTC)

ENGINE (DIAGNOSTICS)

## E: DTC P0018 CRANKSHAFT POSITION - CAMSHAFT POSITION CORRELATION (BANK2)

### DTC DETECTING CONDITION:

- Detected when two consecutive driving cycles with fault occur.
- GENERAL DESCRIPTION <Ref. to GD(H6DO)-19, DTC P0018 CRANKSHAFT POSITION - CAMSHAFT POSITION CORRELATION (BANK2), Diagnostic Trouble Code (DTC) Detecting Criteria.>

### TROUBLE SYMPTOM:

- Engine stalls.
- Improper idling

### CAUTION:

After servicing or replacing faulty parts, perform Clear Memory Mode <Ref. to EN(H6DO)(diag)-62, OPERATION, Clear Memory Mode.>, and Inspection Mode <Ref. to EN(H6DO)(diag)-47, PROCEDURE, Inspection Mode.>.

	Step	Check	Yes	No
1	<p><b>CHECK CURRENT DATA.</b></p> <p>1) Start the engine and let it idle.</p> <p>2) Read the values of «VVT Adv. Ang. Amount L» and «OCV Duty L» using the Subaru Select Monitor.</p> <p>NOTE: For detailed operation procedures, refer to “READ CURRENT DATA FOR ENGINE”. &lt;Ref. to EN(H6DO)(diag)-37, Subaru Select Monitor.&gt;</p>	<p>Is the value of «VVT Adv. Ang. Amount L» approx. 0 deg, and the value of «OCV Duty L» approx. 10%?</p>	<p>Perform the following procedures, and clean the oil routing.</p> <p>Replace the engine oil and idle the engine for 5 minutes, and then replace the oil filter and engine oil.</p> <p>&lt;Ref. to LU(H6DO)-10, REPLACEMENT, Engine Oil.&gt; &lt;Ref. to LU(H6DO)-16, Engine Oil Filter.&gt;</p>	<p>Check the following item and repair or replace if necessary.</p> <ul style="list-style-type: none"> <li>• Oil pipe (clog)</li> <li>• Oil flow control solenoid valve (clog or dirt of oil routing, setting of spring)</li> <li>• Intake camshaft (dirt, damage of camshaft)</li> <li>• Timing chain (matching of timing mark)</li> </ul>

# Diagnostic Procedure with Diagnostic Trouble Code (DTC)

ENGINE (DIAGNOSTICS)

## F: DTC P0019 CRANK AND CAM TIMING B SYSTEM FAILURE (BANK 2)

### DTC DETECTING CONDITION:

- Detected when two consecutive driving cycles with fault occur.
- GENERAL DESCRIPTION <Ref. to GD(H6DO)-19, DTC P0019 CRANK AND CAM TIMING B SYSTEM FAILURE (BANK 2), Diagnostic Trouble Code (DTC) Detecting Criteria.>

### TROUBLE SYMPTOM:

- Engine stalls.
- Improper idling

### CAUTION:

After servicing or replacing faulty parts, perform Clear Memory Mode <Ref. to EN(H6DO)(diag)-62, OPERATION, Clear Memory Mode.>, and Inspection Mode <Ref. to EN(H6DO)(diag)-47, PROCEDURE, Inspection Mode.>.

Step	Check	Yes	No
<b>1</b> <b>CHECK CURRENT DATA.</b> 1) Start the engine and let it idle. 2) Read the values of «Exh. VVT Retard Ang. L» and «Exh. OCV Duty L» using the Subaru Select Monitor.  NOTE: For detailed operation procedures, refer to "READ CURRENT DATA FOR ENGINE". <Ref. to EN(H6DO)(diag)-37, Subaru Select Monitor.>	Is the value of «Exh. VVT Retard Ang. L» approx. 0 deg, and the value of «Exh. OCV Duty L» approx. 10%?	Perform the following procedures, and clean the oil routing.  Replace the engine oil and idle the engine for 5 minutes, and then replace the oil filter and engine oil. <Ref. to LU(H6DO)-10, REPLACEMENT, Engine Oil.> <Ref. to LU(H6DO)-16, Engine Oil Filter.>	Check the following item and repair or replace if necessary. <ul style="list-style-type: none"> <li>• Oil pipe (clog)</li> <li>• Oil flow control solenoid valve (clog or dirt of oil routing, setting of spring)</li> <li>• Exhaust camshaft (dirt, damage of camshaft)</li> <li>• Timing chain (matching of timing mark)</li> </ul>

# Diagnostic Procedure with Diagnostic Trouble Code (DTC)

ENGINE (DIAGNOSTICS)

## G: DTC P0021 INTAKE CAMSHAFT POSITION - TIMING OVER-ADVANCED OR SYSTEM PERFORMANCE (BANK 2)

### DTC DETECTING CONDITION:

- Detected when two consecutive driving cycles with fault occur.
- GENERAL DESCRIPTION <Ref. to GD(H6DO)-19, DTC P0021 INTAKE CAMSHAFT POSITION - TIMING OVER-ADVANCED OR SYSTEM PERFORMANCE (BANK 2), Diagnostic Trouble Code (DTC) Detecting Criteria.>

### TROUBLE SYMPTOM:

- Engine stalls.
- Improper idling

### CAUTION:

After servicing or replacing faulty parts, perform Clear Memory Mode <Ref. to EN(H6DO)(diag)-62, OPERATION, Clear Memory Mode.>, and Inspection Mode <Ref. to EN(H6DO)(diag)-47, PROCEDURE, Inspection Mode.>.

	Step	Check	Yes	No
1	<p><b>CHECK CURRENT DATA.</b></p> <p>1) Start the engine and let it idle.</p> <p>2) Read the value of «VVT Adv. Ang. Amount L» using the Subaru Select Monitor.</p> <p>NOTE: For detailed operation procedures, refer to “READ CURRENT DATA FOR ENGINE”. &lt;Ref. to EN(H6DO)(diag)-37, Subaru Select Monitor.&gt;</p>	Is the value of «VVT Adv. Ang. Amount L» approx. 0 deg?	Go to step 2.	<p>Check the following item and repair or replace if necessary.</p> <ul style="list-style-type: none"> <li>• Oil pipe (clog)</li> <li>• Oil flow control solenoid valve (clog or dirt of oil routing, setting of spring)</li> <li>• Intake camshaft (dirt, damage of camshaft)</li> </ul>
2	<p><b>CHECK CURRENT DATA.</b></p> <p>1) Drive with acceleration and deceleration at 80 km/h (50 MPH) or less.</p> <p>NOTE: Drive to an extent that the duty output of oil flow control solenoid valve increases.</p> <p>2) Read the values of «OCV Duty L» and «VVT Adv. Ang. Amount L» using the Subaru Select Monitor.</p> <p>NOTE: For detailed operation procedures, refer to “READ CURRENT DATA FOR ENGINE”. &lt;Ref. to EN(H6DO)(diag)-37, Subaru Select Monitor.&gt;</p>	When the value of «OCV Duty L» increases more than 10%, is the value of «VVT Adv. Ang. Amount L» approx. 0 deg?	<p>Check the following item and repair or replace if necessary.</p> <ul style="list-style-type: none"> <li>• Oil pipe (clog)</li> <li>• Oil flow control solenoid valve (clog or dirt of oil routing, setting of spring)</li> <li>• Intake camshaft (dirt, damage of camshaft)</li> </ul>	<p>Perform the following procedures, and clean the oil routing.</p> <p>Replace the engine oil and idle the engine for 5 minutes, and then replace the oil filter and engine oil. &lt;Ref. to LU(H6DO)-10, REPLACEMENT, Engine Oil.&gt; &lt;Ref. to LU(H6DO)-16, Engine Oil Filter.&gt;</p>

# Diagnostic Procedure with Diagnostic Trouble Code (DTC)

ENGINE (DIAGNOSTICS)

## H: DTC P0024 EXHAUST AVCS SYSTEM 2 (RANGE/PERFORMANCE)

### DTC DETECTING CONDITION:

- Detected when two consecutive driving cycles with fault occur.
- GENERAL DESCRIPTION <Ref. to GD(H6DO)-19, DTC P0024 EXHAUST AVCS SYSTEM 2 (RANGE/PERFORMANCE), Diagnostic Trouble Code (DTC) Detecting Criteria.>

### TROUBLE SYMPTOM:

- Engine stalls.
- Improper idling

### CAUTION:

After servicing or replacing faulty parts, perform Clear Memory Mode <Ref. to EN(H6DO)(diag)-62, OPERATION, Clear Memory Mode.>, and Inspection Mode <Ref. to EN(H6DO)(diag)-47, PROCEDURE, Inspection Mode.>.

Step	Check	Yes	No
<p><b>1</b></p> <p><b>CHECK CURRENT DATA.</b></p> <p>1) Start the engine and let it idle.</p> <p>2) Read the value of «Exh. VVT Retard Ang. L» using the Subaru Select Monitor.</p> <p>NOTE: For detailed operation procedures, refer to “READ CURRENT DATA FOR ENGINE”. &lt;Ref. to EN(H6DO)(diag)-37, Subaru Select Monitor.&gt;</p>	<p>Is the value of «Exh. VVT Retard Ang. L» approx. 0 deg?</p>	<p>Go to step 2.</p>	<p>Check the following item and repair or replace if necessary.</p> <ul style="list-style-type: none"> <li>• Oil pipe (clog)</li> <li>• Oil flow control solenoid valve (clog or dirt of oil routing, setting of spring)</li> <li>• Exhaust camshaft (dirt, damage of camshaft)</li> </ul>
<p><b>2</b></p> <p><b>CHECK CURRENT DATA.</b></p> <p>1) Drive with acceleration and deceleration at 80 km/h (50 MPH) or less.</p> <p>NOTE: Drive to an extent that the duty output of oil flow control solenoid valve increases.</p> <p>2) Read the values of «Exh. OCV Duty L» and «Exh. VVT Retard Ang. L» using the Subaru Select Monitor.</p> <p>NOTE: For detailed operation procedures, refer to “READ CURRENT DATA FOR ENGINE”. &lt;Ref. to EN(H6DO)(diag)-37, Subaru Select Monitor.&gt;</p>	<p>When the value of «Exh. OCV Duty L» increases more than 10%, is the value of «Exh. VVT Retard Ang. L» approx. 0 deg?</p>	<p>Check the following item and repair or replace if necessary.</p> <ul style="list-style-type: none"> <li>• Oil pipe (clog)</li> <li>• Oil flow control solenoid valve (clog or dirt of oil routing, setting of spring)</li> <li>• Exhaust camshaft (dirt, damage of camshaft)</li> </ul>	<p>Perform the following procedures, and clean the oil routing.</p> <p>Replace the engine oil and idle the engine for 5 minutes, and then replace the oil filter and engine oil.</p> <p>&lt;Ref. to LU(H6DO)-10, REPLACEMENT, Engine Oil.&gt; &lt;Ref. to LU(H6DO)-16, Engine Oil Filter.&gt;</p>



# Diagnostic Procedure with Diagnostic Trouble Code (DTC)

ENGINE (DIAGNOSTICS)

## I: DTC P0030 HO2S HEATER CONTROL CIRCUIT (BANK 1 SENSOR 1)

### DTC DETECTING CONDITION:

- Detected when two consecutive driving cycles with fault occur.
- GENERAL DESCRIPTION <Ref. to GD(H6DO)-20, DTC P0030 HO2S HEATER CONTROL CIRCUIT (BANK 1 SENSOR 1), Diagnostic Trouble Code (DTC) Detecting Criteria.>

### CAUTION:

After servicing or replacing faulty parts, perform Clear Memory Mode <Ref. to EN(H6DO)(diag)-62, OPERATION, Clear Memory Mode.>, and Inspection Mode <Ref. to EN(H6DO)(diag)-47, PROCEDURE, Inspection Mode.>.

### WIRING DIAGRAM:

Engine electrical system <Ref. to WI-32, Engine Electrical System.>

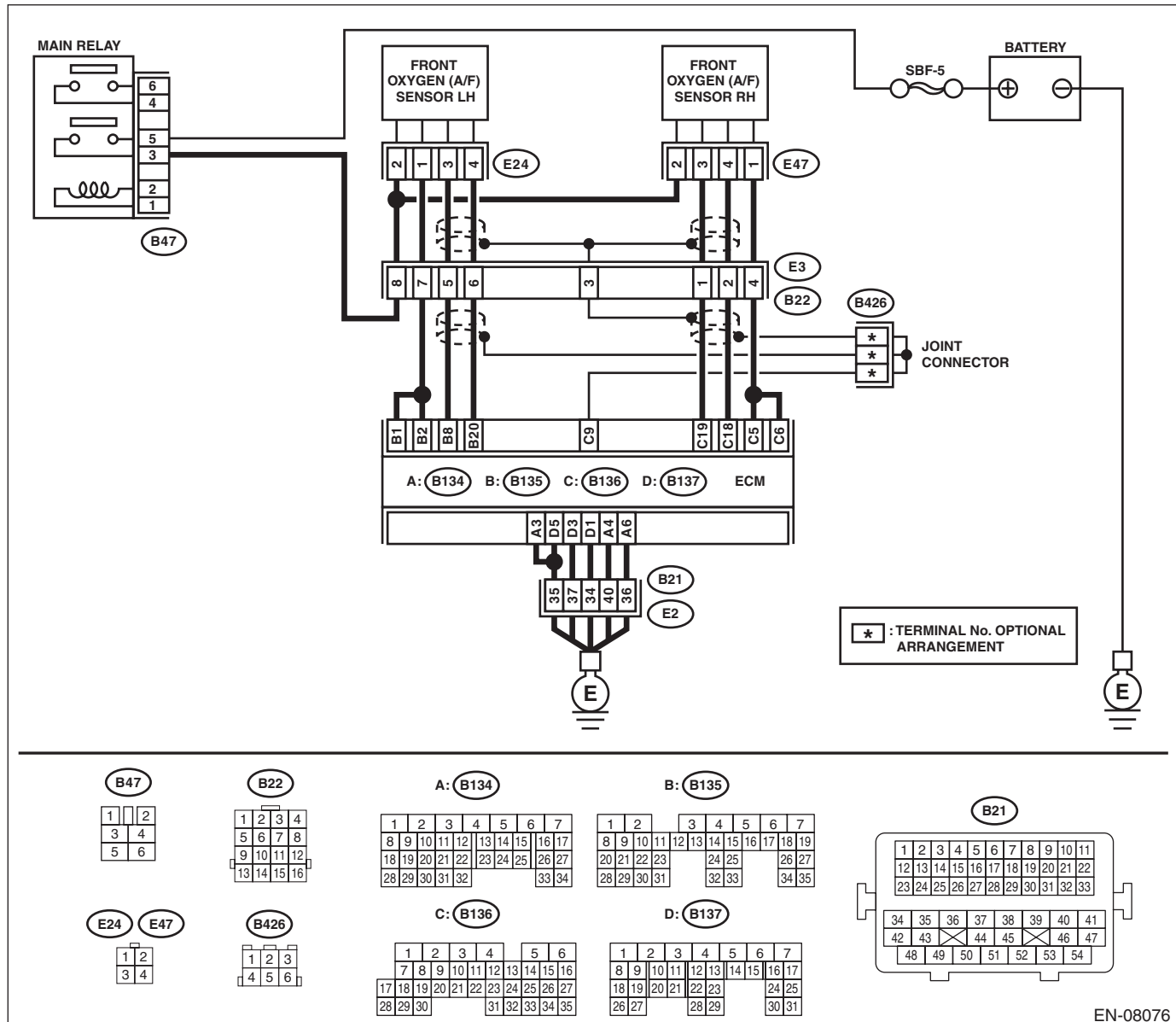

EN-08076

# Diagnostic Procedure with Diagnostic Trouble Code (DTC)

## ENGINE (DIAGNOSTICS)

Step	Check	Yes	No
<p><b>1</b>     <b>CHECK HARNESS BETWEEN ECM AND FRONT OXYGEN (A/F) SENSOR CONNECTOR.</b></p> <p>1) Start and warm up the engine.                  2) Turn the ignition switch to OFF.                  3) Disconnect the connectors from ECM and front oxygen (A/F) sensor.                  4) Measure the resistance of harness between ECM and front oxygen (A/F) sensor connector.</p> <p><b>Connector &amp; terminal</b>  <b>(B136) No. 5 — (E47) No. 1:</b>  <b>(B136) No. 6 — (E47) No. 1:</b>  <b>(B136) No. 19 — (E47) No. 3:</b>  <b>(B136) No. 18 — (E47) No. 4:</b></p>	<p>Is the resistance less than 1 Ω?</p>	<p>Go to step 2.</p>	<p>Repair the harness and connector.</p> <p>NOTE:                  In this case, repair the following item:</p> <ul style="list-style-type: none"> <li>• Open circuit in harness between ECM and front oxygen (A/F) sensor connector</li> <li>• Poor contact of coupling connector</li> </ul>
<p><b>2</b>     <b>CHECK FRONT OXYGEN (A/F) SENSOR.</b>                  Measure the resistance between front oxygen (A/F) sensor connector terminals.</p> <p><b>Terminals</b>  <b>No. 2 — No. 1:</b></p>	<p>Is the resistance 2 — 3 Ω?</p>	<p>Go to step 3.</p>	<p>Replace the front oxygen (A/F) sensor. &lt;Ref. to FU(H6DO)-48, Front Oxygen (A/F) Sensor.&gt;</p>
<p><b>3</b>     <b>CHECK FOR POOR CONTACT.</b>                  Check for poor contact of ECM and front oxygen (A/F) sensor connector.</p>	<p>Is there poor contact of ECM or front oxygen (A/F) sensor connector?</p>	<p>Repair the poor contact of ECM or front oxygen (A/F) sensor connector.</p>	<p>Replace the front oxygen (A/F) sensor. &lt;Ref. to FU(H6DO)-48, Front Oxygen (A/F) Sensor.&gt;</p>

# Diagnostic Procedure with Diagnostic Trouble Code (DTC)

ENGINE (DIAGNOSTICS)

## J: DTC P0031 HO2S HEATER CONTROL CIRCUIT LOW (BANK 1 SENSOR 1)

### DTC DETECTING CONDITION:

- Immediately at fault recognition
- GENERAL DESCRIPTION <Ref. to GD(H6DO)-22, DTC P0031 HO2S HEATER CONTROL CIRCUIT LOW (BANK 1 SENSOR 1), Diagnostic Trouble Code (DTC) Detecting Criteria.>

### CAUTION:

After servicing or replacing faulty parts, perform Clear Memory Mode <Ref. to EN(H6DO)(diag)-62, OPERATION, Clear Memory Mode.>, and Inspection Mode <Ref. to EN(H6DO)(diag)-47, PROCEDURE, Inspection Mode.>.

### WIRING DIAGRAM:

Engine electrical system <Ref. to WI-32, Engine Electrical System.>

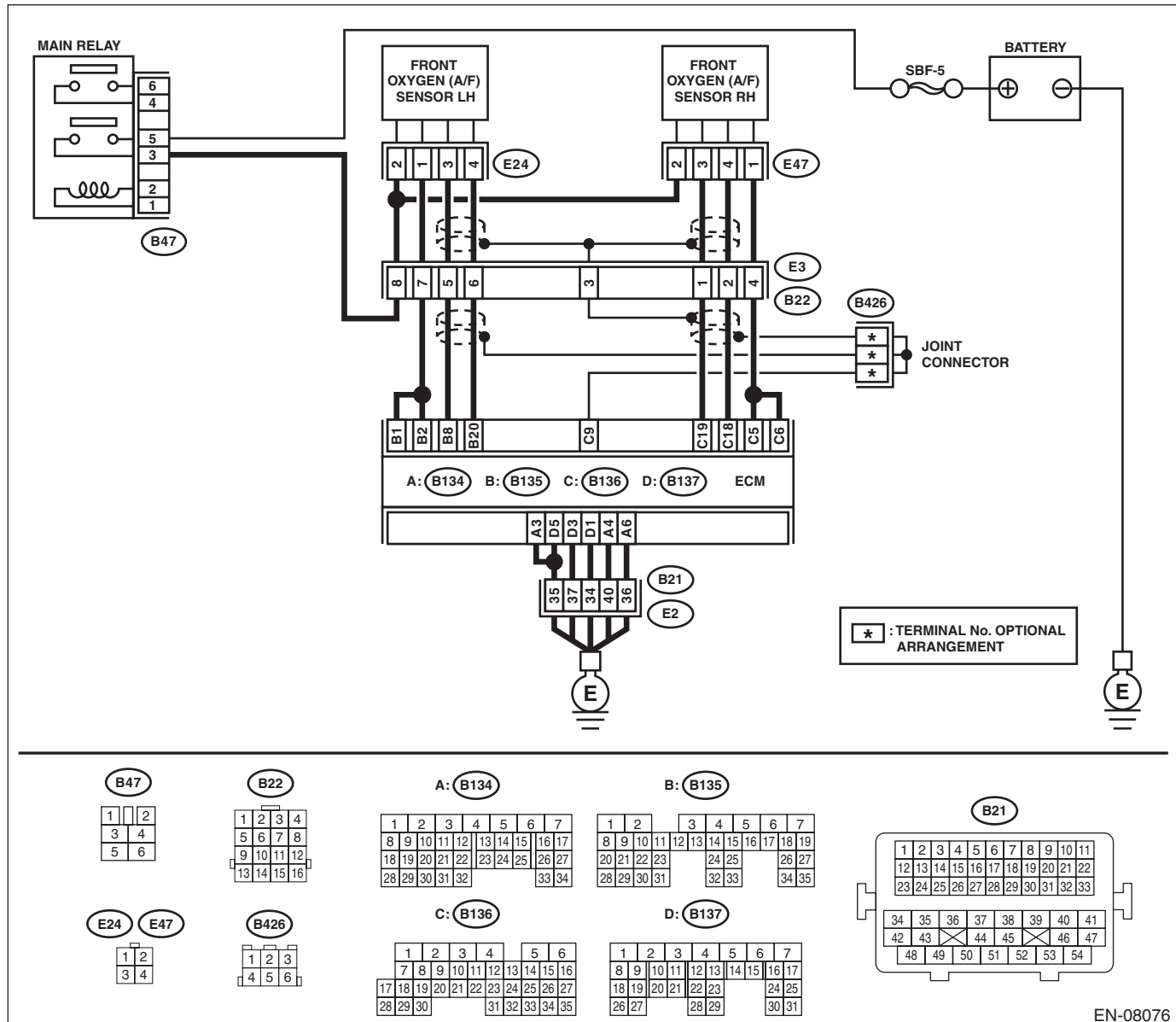

EN-08076

# Diagnostic Procedure with Diagnostic Trouble Code (DTC)

## ENGINE (DIAGNOSTICS)

Step	Check	Yes	No
<p><b>1 CHECK POWER SUPPLY TO FRONT OXYGEN (A/F) SENSOR.</b></p> <p>1) Turn the ignition switch to OFF.                      2) Disconnect the connectors from front oxygen (A/F) sensor.                      3) Turn the ignition switch to ON.                      4) Measure the voltage between front oxygen (A/F) sensor connector and engine ground.</p> <p><b>Connector &amp; terminal</b>  <b>(E47) No. 2 (+) — Engine ground (-):</b></p>	Is the voltage 10 V or more?	Go to step 2.	Repair the power supply line. NOTE: In this case, repair the following item: <ul style="list-style-type: none"> <li>• Open circuit of harness between main relay and front oxygen (A/F) sensor connector</li> <li>• Poor contact of main relay connector</li> <li>• Poor contact of coupling connector</li> <li>• Defective main relay</li> </ul>
<p><b>2 CHECK HARNESS BETWEEN ECM AND FRONT OXYGEN (A/F) SENSOR CONNECTOR.</b></p> <p>1) Turn the ignition switch to OFF.                      2) Disconnect the connector from ECM.                      3) Measure the resistance between ECM and front oxygen (A/F) sensor connector.</p> <p><b>Connector &amp; terminal</b>  <b>(B136) No. 5 — (E47) No. 1:</b>  <b>(B136) No. 6 — (E47) No. 1:</b></p>	Is the resistance less than 1 Ω?	Go to step 3.	Repair the harness and connector. NOTE: In this case, repair the following item: <ul style="list-style-type: none"> <li>• Open circuit in harness between ECM and front oxygen (A/F) sensor connector</li> <li>• Poor contact of coupling connector</li> </ul>
<p><b>3 CHECK GROUND CIRCUIT FOR ECM.</b></p> <p>Measure the resistance of harness between ECM and chassis ground.</p> <p><b>Connector &amp; terminal</b>  <b>(B134) No. 3 — Chassis ground:</b>  <b>(B134) No. 4 — Chassis ground:</b>  <b>(B134) No. 6 — Chassis ground:</b>  <b>(B137) No. 1 — Chassis ground:</b>  <b>(B137) No. 3 — Chassis ground:</b>  <b>(B137) No. 5 — Chassis ground:</b></p>	Is the resistance less than 5 Ω?	Go to step 4.	Repair the harness and connector. NOTE: In this case, repair the following item: <ul style="list-style-type: none"> <li>• Open circuit of harness between ECM and engine ground</li> <li>• Poor contact of coupling connector</li> </ul>
<p><b>4 CHECK FRONT OXYGEN (A/F) SENSOR.</b></p> <p>Measure the resistance between front oxygen (A/F) sensor connector terminals.</p> <p><b>Terminals</b>  <b>No. 2 — No. 1:</b></p>	Is the resistance 2 — 3 Ω?	Repair the poor contact of ECM connector.	Replace the front oxygen (A/F) sensor. <Ref. to FU(H6DO)-48, Front Oxygen (A/F) Sensor.>

# Diagnostic Procedure with Diagnostic Trouble Code (DTC)

ENGINE (DIAGNOSTICS)

## K: DTC P0032 HO2S HEATER CONTROL CIRCUIT HIGH (BANK 1 SENSOR 1)

### DTC DETECTING CONDITION:

- Immediately at fault recognition
- GENERAL DESCRIPTION <Ref. to GD(H6DO)-24, DTC P0032 HO2S HEATER CONTROL CIRCUIT HIGH (BANK 1 SENSOR 1), Diagnostic Trouble Code (DTC) Detecting Criteria.>

### CAUTION:

After servicing or replacing faulty parts, perform Clear Memory Mode <Ref. to EN(H6DO)(diag)-62, OPERATION, Clear Memory Mode.>, and Inspection Mode <Ref. to EN(H6DO)(diag)-47, PROCEDURE, Inspection Mode.>.

### WIRING DIAGRAM:

Engine electrical system <Ref. to WI-32, Engine Electrical System.>

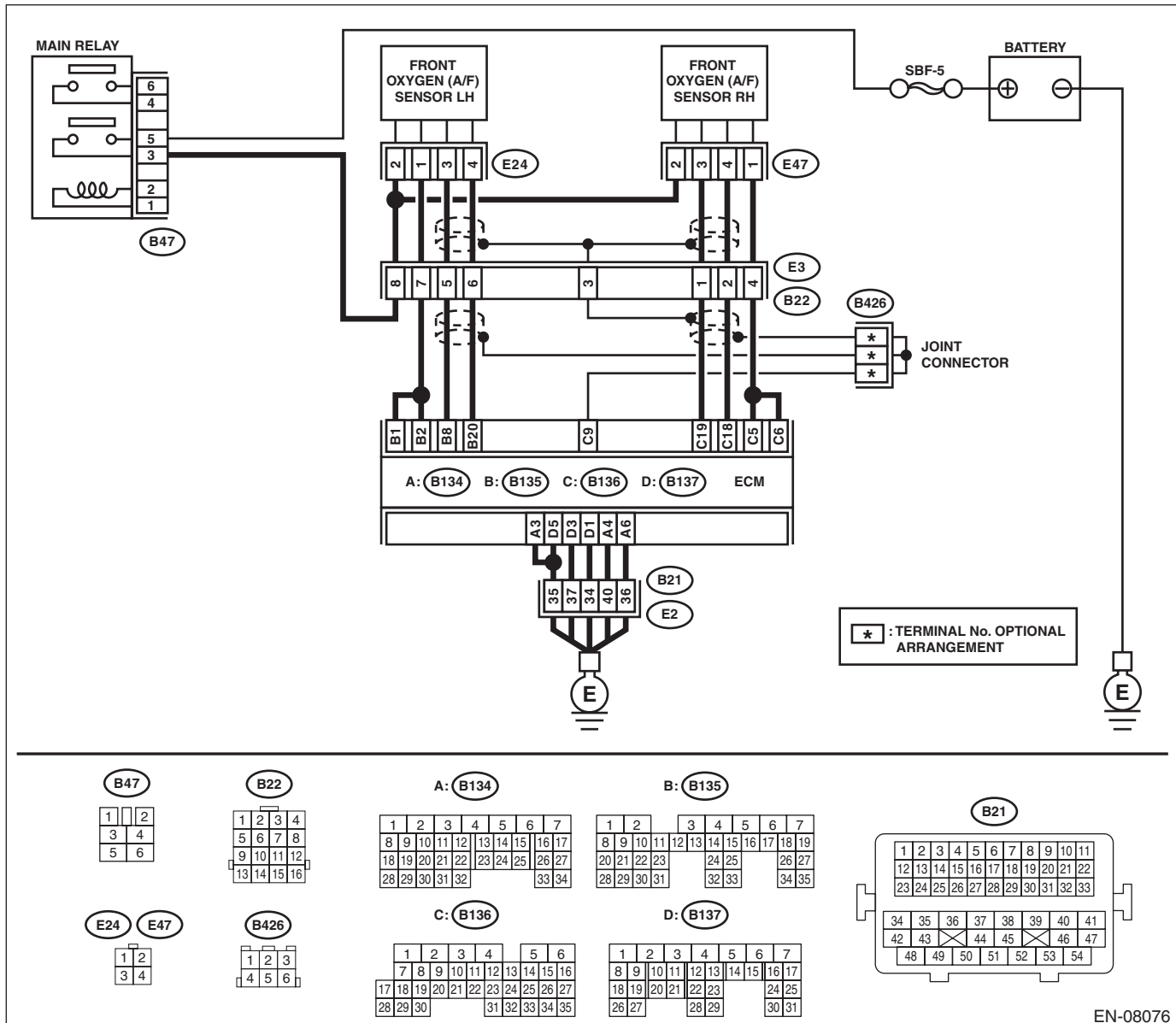

EN-08076

# Diagnostic Procedure with Diagnostic Trouble Code (DTC)

## ENGINE (DIAGNOSTICS)

Step	Check	Yes	No
<p><b>1</b>     <b>CHECK HARNESS BETWEEN ECM AND FRONT OXYGEN (A/F) SENSOR CONNECTOR.</b></p> <p>1) Turn the ignition switch to OFF. 2) Measure the voltage between ECM and chassis ground.</p> <p><b>Connector &amp; terminal</b> <b>(B136) No. 5 (+) — Chassis ground (-):</b> <b>(B136) No. 6 (+) — Chassis ground (-):</b></p>	<p>Is the voltage 10 V or more?</p>	<p>Repair the short circuit to power in the harness between ECM and front oxygen (A/F) sensor connector.</p>	<p>Go to step 2.</p>
<p><b>2</b>     <b>CHECK GROUND CIRCUIT FOR ECM.</b></p> <p>1) Disconnect the connector from ECM. 2) Measure the resistance between ECM and chassis ground.</p> <p><b>Connector &amp; terminal</b> <b>(B134) No. 3 — Chassis ground:</b> <b>(B134) No. 4 — Chassis ground:</b> <b>(B134) No. 6 — Chassis ground:</b> <b>(B137) No. 1 — Chassis ground:</b> <b>(B137) No. 3 — Chassis ground:</b> <b>(B137) No. 5 — Chassis ground:</b></p>	<p>Is the resistance less than 5 Ω?</p>	<p>Repair the poor contact of ECM connector.</p>	<p>Repair the harness and connector.</p> <p><b>NOTE:</b> In this case, repair the following item:</p> <ul style="list-style-type: none"> <li>• Open circuit of harness between ECM and engine ground</li> <li>• Poor contact of coupling connector</li> </ul>

# Diagnostic Procedure with Diagnostic Trouble Code (DTC)

ENGINE (DIAGNOSTICS)

## L: DTC P0037 HO2S HEATER CONTROL CIRCUIT LOW (BANK 1 SENSOR 2)

### DTC DETECTING CONDITION:

- Detected when two consecutive driving cycles with fault occur.
- GENERAL DESCRIPTION <Ref. to GD(H6DO)-26, DTC P0037 HO2S HEATER CONTROL CIRCUIT LOW (BANK 1 SENSOR 2), Diagnostic Trouble Code (DTC) Detecting Criteria.>

### CAUTION:

After servicing or replacing faulty parts, perform Clear Memory Mode <Ref. to EN(H6DO)(diag)-62, OPERATION, Clear Memory Mode.>, and Inspection Mode <Ref. to EN(H6DO)(diag)-47, PROCEDURE, Inspection Mode.>.

### WIRING DIAGRAM:

Engine electrical system <Ref. to WI-32, Engine Electrical System.>

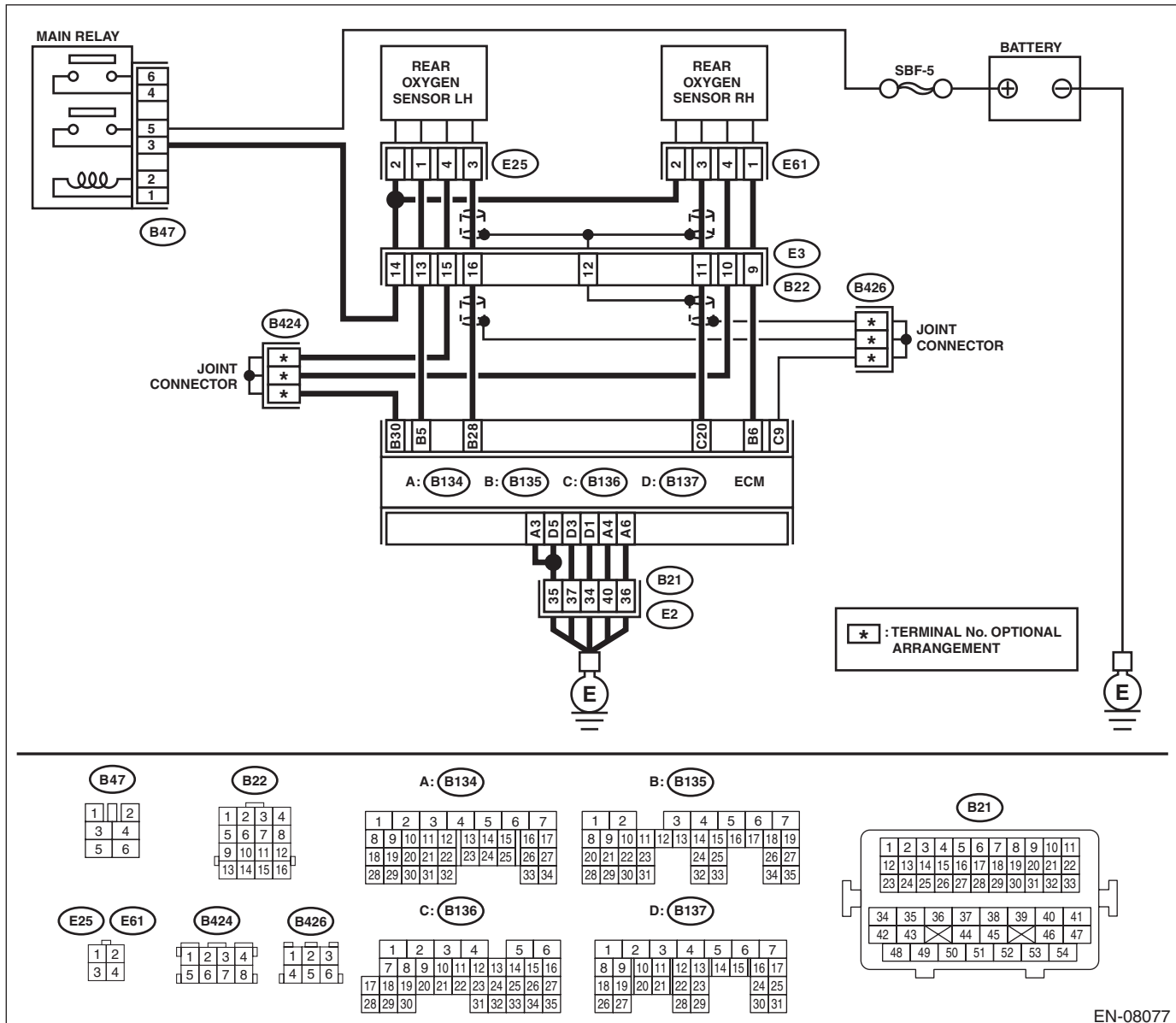

EN-08077

# Diagnostic Procedure with Diagnostic Trouble Code (DTC)

ENGINE (DIAGNOSTICS)

Step	Check	Yes	No
<p><b>1 CHECK POWER SUPPLY TO REAR OXYGEN SENSOR.</b></p> <p>1) Turn the ignition switch to OFF.                      2) Disconnect the connector from rear oxygen sensor.                      3) Turn the ignition switch to ON.                      4) Measure the voltage between rear oxygen sensor connector and engine ground.</p> <p><b>Connector &amp; terminal</b>  <b>(E61) No. 2 (+) — Engine ground (-):</b></p>	Is the voltage 10 V or more?	Go to step 2.	Repair the power supply line. NOTE: In this case, repair the following item: <ul style="list-style-type: none"> <li>• Open circuit of harness between main relay and rear oxygen sensor connector</li> <li>• Poor contact of main relay connector</li> <li>• Poor contact of coupling connector</li> <li>• Defective main relay</li> </ul>
<p><b>2 CHECK HARNESS BETWEEN ECM AND REAR OXYGEN SENSOR CONNECTOR.</b></p> <p>1) Turn the ignition switch to OFF.                      2) Disconnect the connector from ECM.                      3) Measure the resistance between ECM and oxygen sensor connector.</p> <p><b>Connector &amp; terminal</b>  <b>(B135) No. 6 — (E61) No. 1:</b></p>	Is the resistance less than 1 $\Omega$ ?	Go to step 3.	Repair the harness and connector. NOTE: In this case, repair the following item: <ul style="list-style-type: none"> <li>• Open circuit in harness between ECM and rear oxygen sensor connector</li> <li>• Poor contact of coupling connector</li> </ul>
<p><b>3 CHECK GROUND CIRCUIT FOR ECM.</b></p> <p>Measure the resistance of harness between ECM and chassis ground.</p> <p><b>Connector &amp; terminal</b>  <b>(B134) No. 3 — Chassis ground:</b>  <b>(B134) No. 4 — Chassis ground:</b>  <b>(B134) No. 6 — Chassis ground:</b>  <b>(B137) No. 1 — Chassis ground:</b>  <b>(B137) No. 3 — Chassis ground:</b>  <b>(B137) No. 5 — Chassis ground:</b></p>	Is the resistance less than 5 $\Omega$ ?	Go to step 4.	Repair the harness and connector. NOTE: In this case, repair the following item: <ul style="list-style-type: none"> <li>• Open circuit of harness between ECM and engine ground</li> <li>• Poor contact of coupling connector</li> </ul>
<p><b>4 CHECK REAR OXYGEN SENSOR.</b></p> <p>Measure the resistance between rear oxygen sensor connector terminals.</p> <p><b>Terminals</b>  <b>No. 2 — No. 1:</b></p>	Is the resistance 5 — 7 $\Omega$ ?	Repair the poor contact of ECM connector.	Replace the rear oxygen sensor. <Ref. to FU(H6DO)-50, Rear Oxygen Sensor.>



# Diagnostic Procedure with Diagnostic Trouble Code (DTC)

ENGINE (DIAGNOSTICS)

## M: DTC P0038 HO2S HEATER CONTROL CIRCUIT HIGH (BANK 1 SENSOR 2)

### DTC DETECTING CONDITION:

- Detected when two consecutive driving cycles with fault occur.
- GENERAL DESCRIPTION <Ref. to GD(H6DO)-28, DTC P0038 HO2S HEATER CONTROL CIRCUIT HIGH (BANK 1 SENSOR 2), Diagnostic Trouble Code (DTC) Detecting Criteria.>

### CAUTION:

After servicing or replacing faulty parts, perform Clear Memory Mode <Ref. to EN(H6DO)(diag)-62, OPERATION, Clear Memory Mode.>, and Inspection Mode <Ref. to EN(H6DO)(diag)-47, PROCEDURE, Inspection Mode.>.

### WIRING DIAGRAM:

Engine electrical system <Ref. to WI-32, Engine Electrical System.>

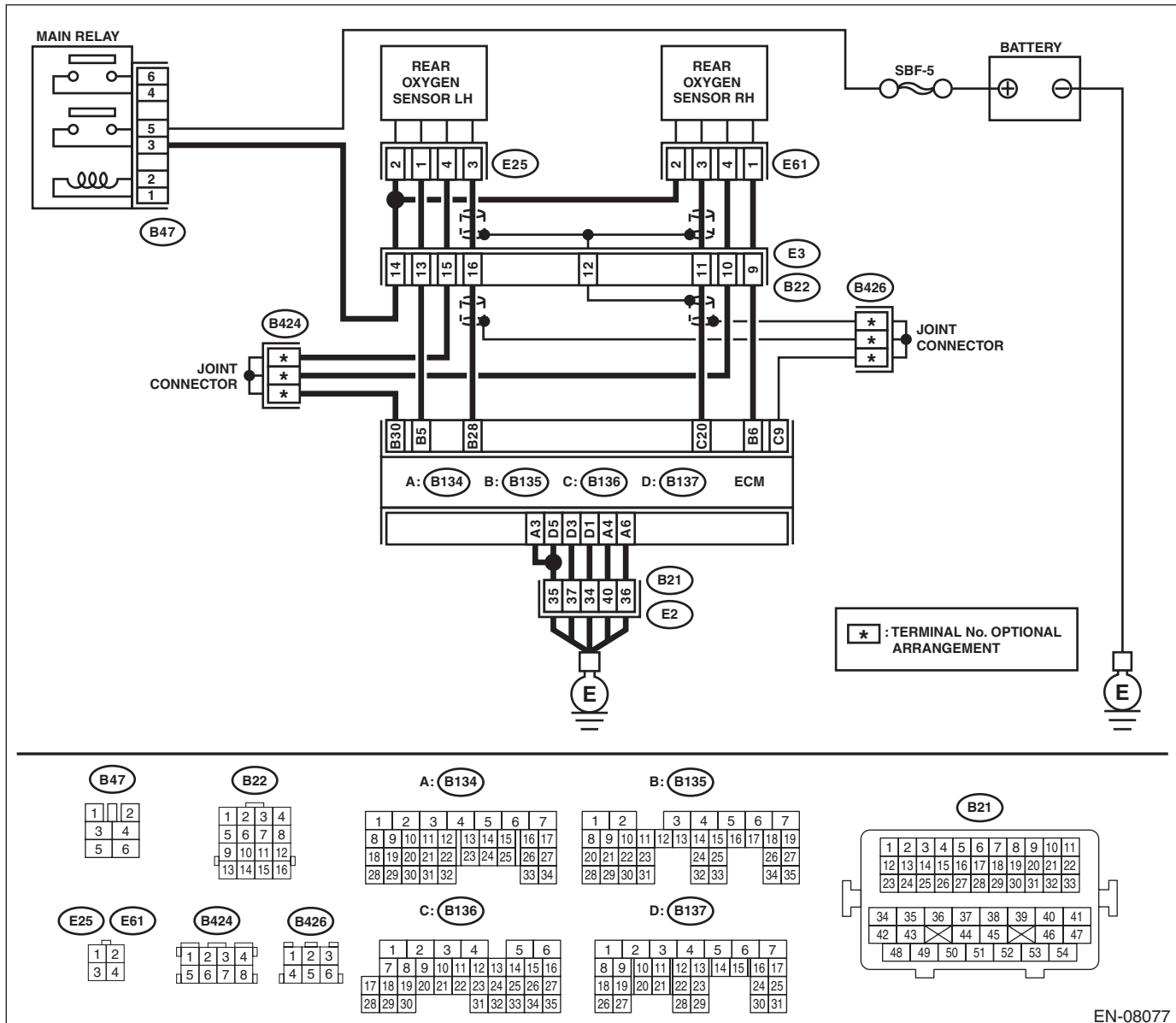

EN-08077

# Diagnostic Procedure with Diagnostic Trouble Code (DTC)

## ENGINE (DIAGNOSTICS)

Step	Check	Yes	No
<b>1 CHECK HARNESS BETWEEN ECM AND REAR OXYGEN SENSOR CONNECTOR.</b> 1) Turn the ignition switch to OFF. 2) Measure the voltage between ECM and chassis ground. <i><b>Connector &amp; terminal</b></i> <i><b>(B135) No. 6 (+) — Chassis ground (-):</b></i>	Is the voltage 10 V or more?	Repair the short circuit to power in the harness between ECM and rear oxygen sensor connector.	Go to step 2.
<b>2 CHECK GROUND CIRCUIT FOR ECM.</b> 1) Disconnect the connector from ECM. 2) Measure the resistance between ECM and chassis ground. <i><b>Connector &amp; terminal</b></i> <i><b>(B134) No. 3 — Chassis ground:</b></i> <i><b>(B134) No. 4 — Chassis ground:</b></i> <i><b>(B134) No. 6 — Chassis ground:</b></i> <i><b>(B137) No. 1 — Chassis ground:</b></i> <i><b>(B137) No. 3 — Chassis ground:</b></i> <i><b>(B137) No. 5 — Chassis ground:</b></i>	Is the resistance less than 5 $\Omega$ ?	Repair the poor contact of ECM connector.	Repair the harness and connector. NOTE: In this case, repair the following item: • Open circuit of harness between ECM and engine ground • Poor contact of coupling connector

# Diagnostic Procedure with Diagnostic Trouble Code (DTC)

ENGINE (DIAGNOSTICS)

## N: DTC P0050 HO2S HEATER CONTROL CIRCUIT (BANK 2 SENSOR 1)

### DTC DETECTING CONDITION:

- Detected when two consecutive driving cycles with fault occur.
- GENERAL DESCRIPTION <Ref. to GD(H6DO)-29, DTC P0050 HO2S HEATER CONTROL CIRCUIT (BANK 2 SENSOR 1), Diagnostic Trouble Code (DTC) Detecting Criteria.>

### CAUTION:

After servicing or replacing faulty parts, perform Clear Memory Mode <Ref. to EN(H6DO)(diag)-62, OPERATION, Clear Memory Mode.>, and Inspection Mode <Ref. to EN(H6DO)(diag)-47, PROCEDURE, Inspection Mode.>.

### WIRING DIAGRAM:

Engine electrical system <Ref. to WI-32, Engine Electrical System.>

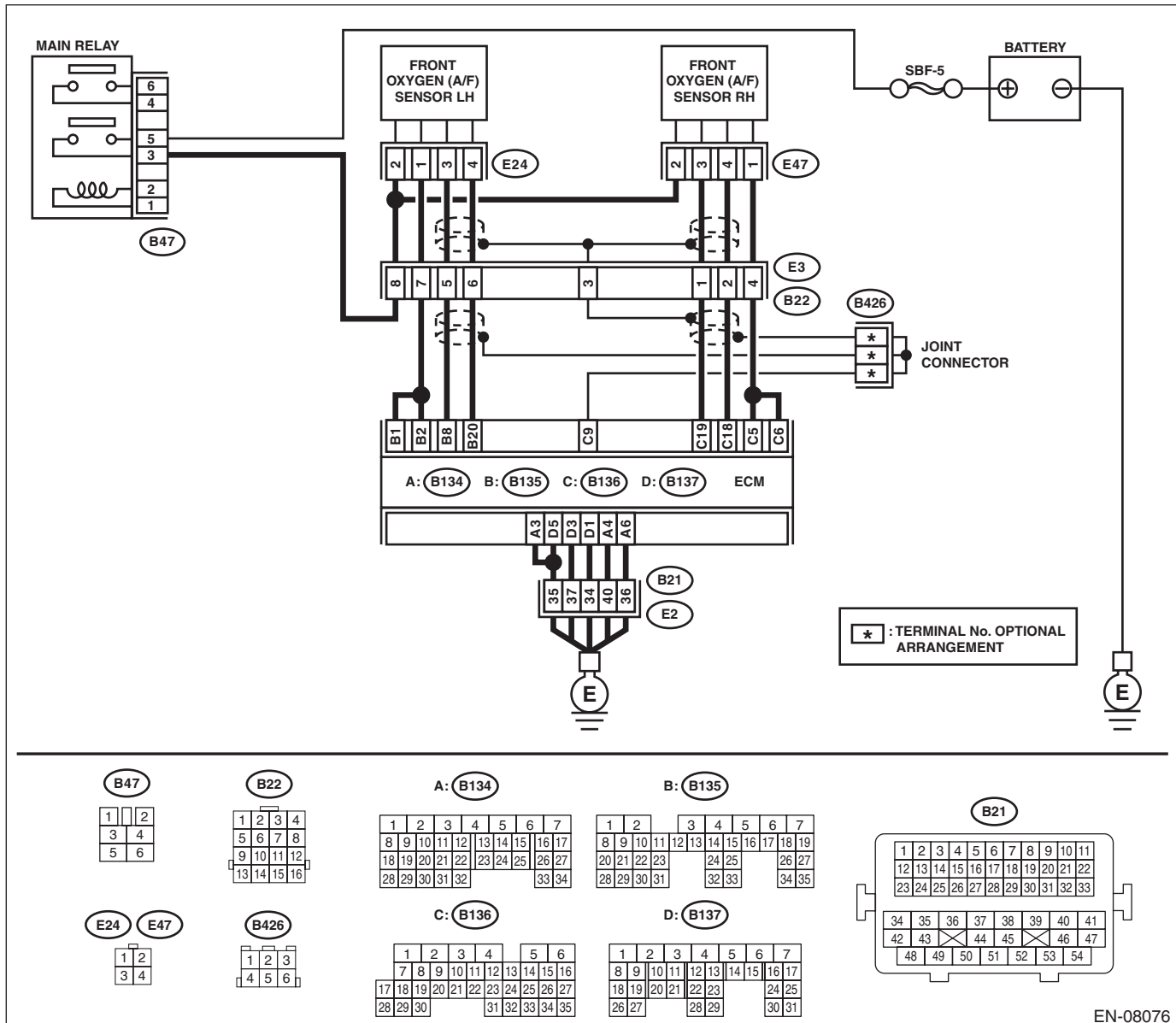

EN-08076

# Diagnostic Procedure with Diagnostic Trouble Code (DTC)

ENGINE (DIAGNOSTICS)

Step	Check	Yes	No
<p><b>1</b>     <b>CHECK HARNESS BETWEEN ECM AND FRONT OXYGEN (A/F) SENSOR CONNECTOR.</b></p> <p>1) Start and warm up the engine.                  2) Turn the ignition switch to OFF.                  3) Disconnect the connectors from ECM and front oxygen (A/F) sensor.                  4) Measure the resistance of harness between ECM and front oxygen (A/F) sensor connector.</p> <p><b>Connector &amp; terminal</b>  <b>(B135) No. 1 — (E24) No. 1:</b>  <b>(B135) No. 2 — (E24) No. 1:</b>  <b>(B135) No. 8 — (E24) No. 3:</b>  <b>(B135) No. 20 — (E24) No. 4:</b></p>	Is the resistance less than 1 Ω?	Go to step 2.	Repair the harness and connector.  NOTE: In this case, repair the following item: <ul style="list-style-type: none"> <li>• Open circuit in harness between ECM and front oxygen (A/F) sensor connector</li> <li>• Poor contact of coupling connector</li> </ul>
<p><b>2</b>     <b>CHECK FRONT OXYGEN (A/F) SENSOR.</b>                  Measure the resistance between front oxygen (A/F) sensor connector terminals.</p> <p><b>Terminals</b>  <b>No. 2 — No. 1:</b></p>	Is the resistance 2 — 3 Ω?	Go to step 3.	Replace the front oxygen (A/F) sensor. <Ref. to FU(H6DO)-48, Front Oxygen (A/F) Sensor.>
<p><b>3</b>     <b>CHECK FOR POOR CONTACT.</b>                  Check for poor contact of ECM and front oxygen (A/F) sensor connector.</p>	Is there poor contact of ECM or front oxygen (A/F) sensor connector?	Repair the poor contact of ECM or front oxygen (A/F) sensor connector.	Replace the front oxygen (A/F) sensor. <Ref. to FU(H6DO)-48, Front Oxygen (A/F) Sensor.>

# Diagnostic Procedure with Diagnostic Trouble Code (DTC)

ENGINE (DIAGNOSTICS)

## O: DTC P0051 HO2S HEATER CONTROL CIRCUIT LOW (BANK 2 SENSOR 1)

### DTC DETECTING CONDITION:

- Immediately at fault recognition
- GENERAL DESCRIPTION <Ref. to GD(H6DO)-29, DTC P0051 HO2S HEATER CONTROL CIRCUIT LOW (BANK 2 SENSOR 1), Diagnostic Trouble Code (DTC) Detecting Criteria.>

### CAUTION:

After servicing or replacing faulty parts, perform Clear Memory Mode <Ref. to EN(H6DO)(diag)-62, OPERATION, Clear Memory Mode.>, and Inspection Mode <Ref. to EN(H6DO)(diag)-47, PROCEDURE, Inspection Mode.>.

### WIRING DIAGRAM:

Engine electrical system <Ref. to WI-32, Engine Electrical System.>

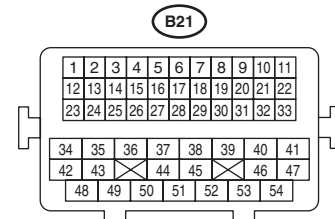
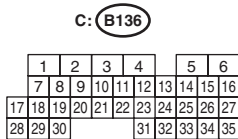
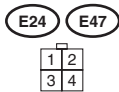
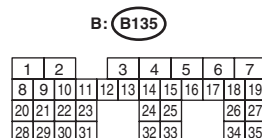
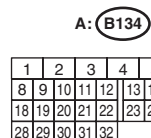
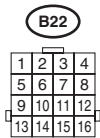
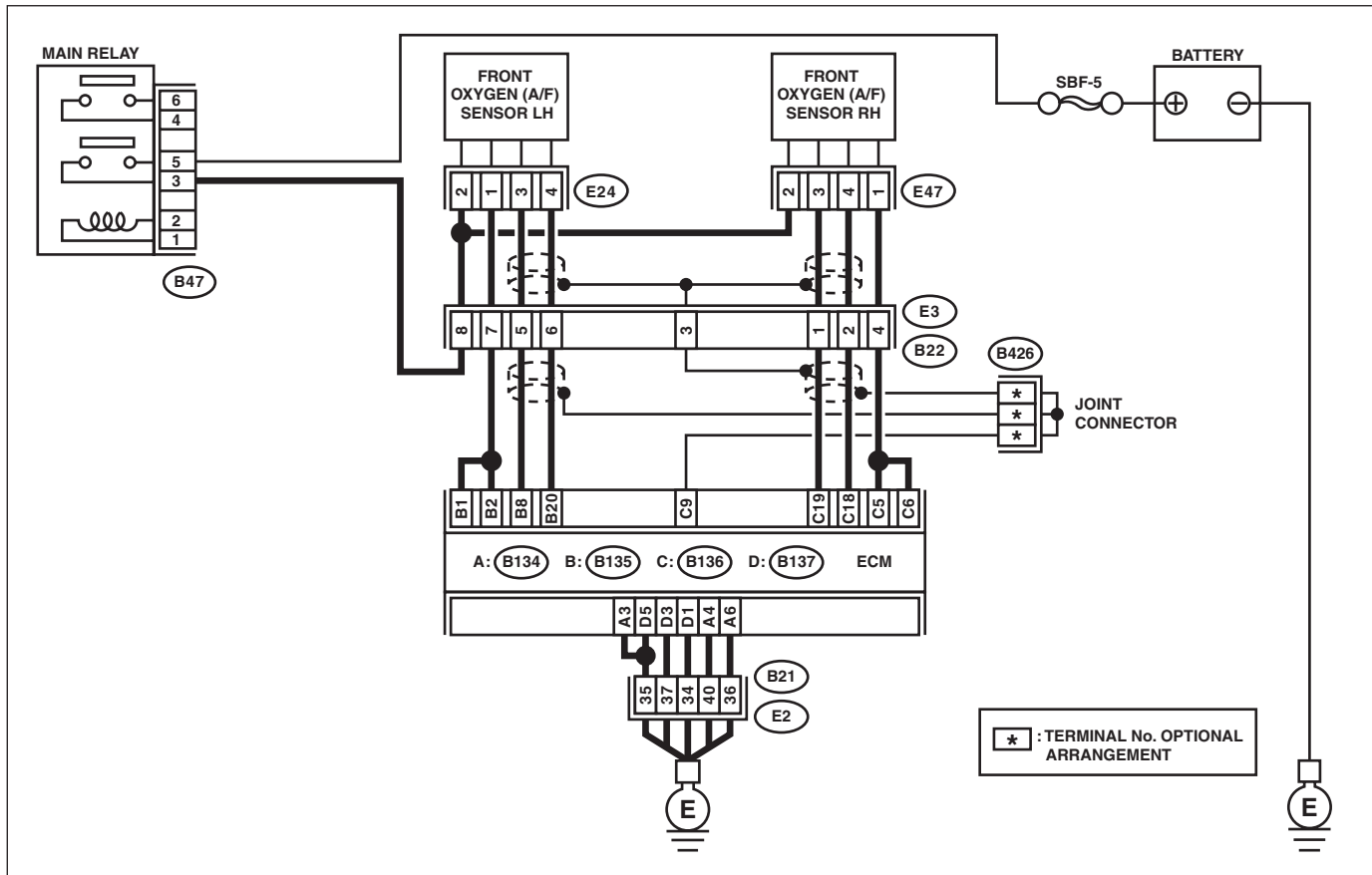

EN-08076

# Diagnostic Procedure with Diagnostic Trouble Code (DTC)

## ENGINE (DIAGNOSTICS)

Step	Check	Yes	No
<p><b>1 CHECK POWER SUPPLY TO FRONT OXYGEN (A/F) SENSOR.</b></p> <p>1) Turn the ignition switch to OFF.                      2) Disconnect the connectors from front oxygen (A/F) sensor.                      3) Turn the ignition switch to ON.                      4) Measure the voltage between front oxygen (A/F) sensor connector and engine ground.</p> <p><b>Connector &amp; terminal</b>  <b>(E24) No. 2 (+) — Engine ground (-):</b></p>	Is the voltage 10 V or more?	Go to step 2.	Repair the power supply line. NOTE: In this case, repair the following item: <ul style="list-style-type: none"> <li>• Open circuit of harness between main relay and front oxygen (A/F) sensor connector</li> <li>• Poor contact of main relay connector</li> <li>• Poor contact of coupling connector</li> <li>• Defective main relay</li> </ul>
<p><b>2 CHECK HARNESS BETWEEN ECM AND FRONT OXYGEN (A/F) SENSOR CONNECTOR.</b></p> <p>1) Turn the ignition switch to OFF.                      2) Disconnect the connector from ECM.                      3) Measure the resistance between ECM and front oxygen (A/F) sensor connector.</p> <p><b>Connector &amp; terminal</b>  <b>(B135) No. 1 — (E24) No. 1:</b>  <b>(B135) No. 2 — (E24) No. 1:</b></p>	Is the resistance less than 1 $\Omega$ ?	Go to step 3.	Repair the harness and connector. NOTE: In this case, repair the following item: <ul style="list-style-type: none"> <li>• Open circuit in harness between ECM and front oxygen (A/F) sensor connector</li> <li>• Poor contact of coupling connector</li> </ul>
<p><b>3 CHECK GROUND CIRCUIT FOR ECM.</b></p> <p>Measure the resistance of harness between ECM and chassis ground.</p> <p><b>Connector &amp; terminal</b>  <b>(B134) No. 3 — Chassis ground:</b>  <b>(B134) No. 4 — Chassis ground:</b>  <b>(B134) No. 6 — Chassis ground:</b>  <b>(B137) No. 1 — Chassis ground:</b>  <b>(B137) No. 3 — Chassis ground:</b>  <b>(B137) No. 5 — Chassis ground:</b></p>	Is the resistance less than 5 $\Omega$ ?	Go to step 4.	Repair the harness and connector. NOTE: In this case, repair the following item: <ul style="list-style-type: none"> <li>• Open circuit of harness between ECM and engine ground</li> <li>• Poor contact of coupling connector</li> </ul>
<p><b>4 CHECK FRONT OXYGEN (A/F) SENSOR.</b></p> <p>Measure the resistance between front oxygen (A/F) sensor connector terminals.</p> <p><b>Terminals</b>  <b>No. 2 — No. 1:</b></p>	Is the resistance 2 — 3 $\Omega$ ?	Repair the poor contact of ECM connector.	Replace the front oxygen (A/F) sensor. <Ref. to FU(H6DO)-48, Front Oxygen (A/F) Sensor.>

# Diagnostic Procedure with Diagnostic Trouble Code (DTC)

ENGINE (DIAGNOSTICS)

## P: DTC P0052 HO2S HEATER CONTROL CIRCUIT HIGH (BANK 2 SENSOR 1)

### DTC DETECTING CONDITION:

- Immediately at fault recognition
- GENERAL DESCRIPTION <Ref. to GD(H6DO)-29, DTC P0052 HO2S HEATER CONTROL CIRCUIT HIGH (BANK 2 SENSOR 1), Diagnostic Trouble Code (DTC) Detecting Criteria.>

### CAUTION:

After servicing or replacing faulty parts, perform Clear Memory Mode <Ref. to EN(H6DO)(diag)-62, OPERATION, Clear Memory Mode.>, and Inspection Mode <Ref. to EN(H6DO)(diag)-47, PROCEDURE, Inspection Mode.>.

### WIRING DIAGRAM:

Engine electrical system <Ref. to WI-32, Engine Electrical System.>

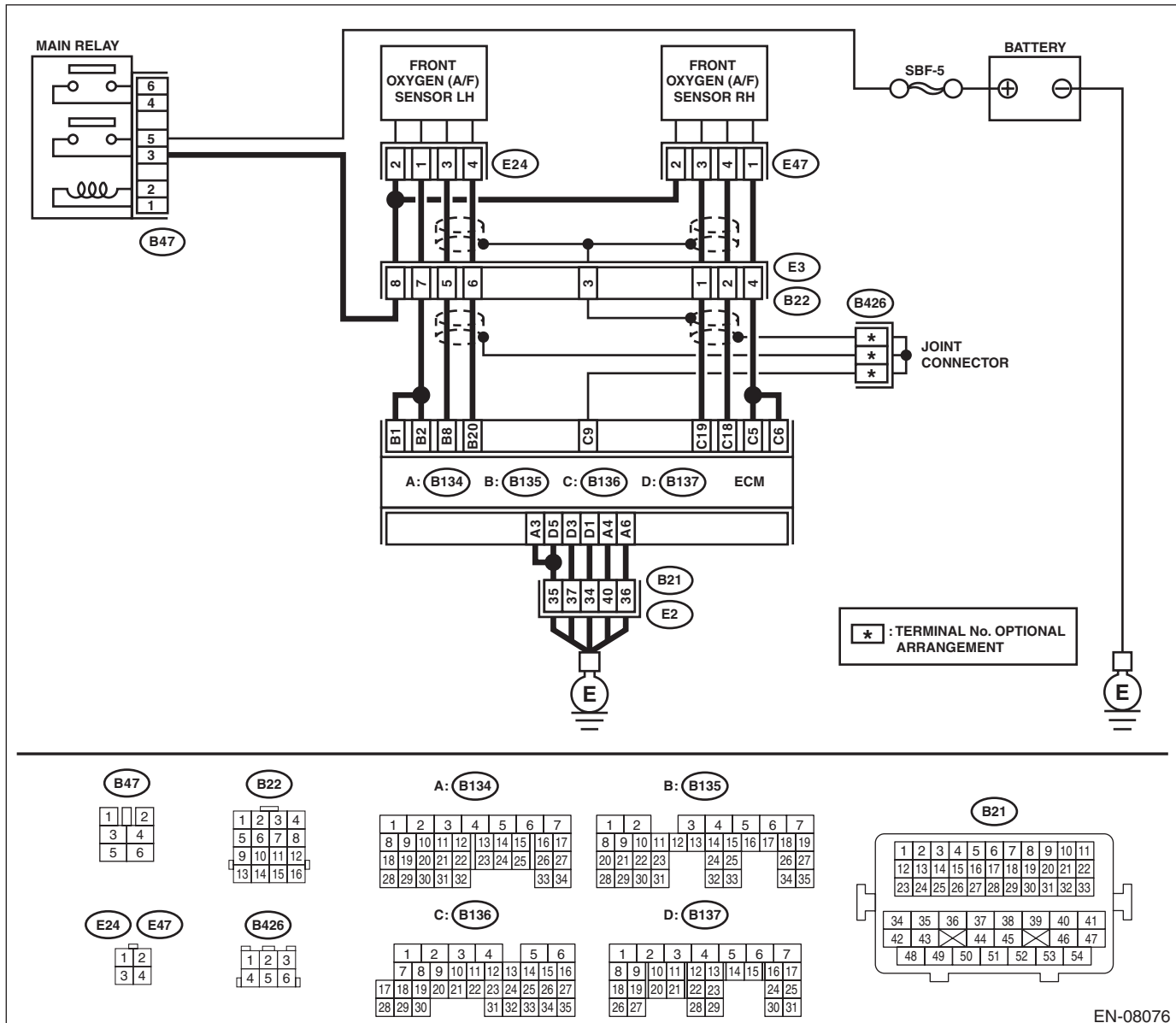

EN-08076

# Diagnostic Procedure with Diagnostic Trouble Code (DTC)

ENGINE (DIAGNOSTICS)

Step	Check	Yes	No
<p><b>1</b>    <b>CHECK HARNESS BETWEEN ECM AND FRONT OXYGEN (A/F) SENSOR CONNECTOR.</b>            1) Turn the ignition switch to OFF.            2) Measure the voltage between ECM and chassis ground.  <b>Connector &amp; terminal</b>  <b>(B135) No. 1 (+) — Chassis ground (-):</b>  <b>(B135) No. 2 (+) — Chassis ground (-):</b></p>	<p>Is the voltage 10 V or more?</p>	<p>Repair the short circuit to power in the harness between ECM and front oxygen (A/F) sensor connector.</p>	<p>Go to step 2.</p>
<p><b>2</b>    <b>CHECK GROUND CIRCUIT FOR ECM.</b>            1) Disconnect the connector from ECM.            2) Measure the resistance between ECM and chassis ground.  <b>Connector &amp; terminal</b>  <b>(B134) No. 3 — Chassis ground:</b>  <b>(B134) No. 4 — Chassis ground:</b>  <b>(B134) No. 6 — Chassis ground:</b>  <b>(B137) No. 1 — Chassis ground:</b>  <b>(B137) No. 3 — Chassis ground:</b>  <b>(B137) No. 5 — Chassis ground:</b></p>	<p>Is the resistance less than 5 Ω?</p>	<p>Repair the poor contact of ECM connector.</p>	<p>Repair the harness and connector.  <b>NOTE:</b>            In this case, repair the following item:  <ul style="list-style-type: none"> <li>• Open circuit of harness between ECM and engine ground</li> <li>• Poor contact of coupling connector</li> </ul> </p>



# Diagnostic Procedure with Diagnostic Trouble Code (DTC)

ENGINE (DIAGNOSTICS)

## Q: DTC P0057 HO2S HEATER CONTROL CIRCUIT LOW (BANK 2 SENSOR 2)

### DTC DETECTING CONDITION:

- Detected when two consecutive driving cycles with fault occur.
- GENERAL DESCRIPTION <Ref. to GD(H6DO)-29, DTC P0057 HO2S HEATER CONTROL CIRCUIT LOW (BANK 2 SENSOR 2), Diagnostic Trouble Code (DTC) Detecting Criteria.>

### CAUTION:

After servicing or replacing faulty parts, perform Clear Memory Mode <Ref. to EN(H6DO)(diag)-62, OPERATION, Clear Memory Mode.>, and Inspection Mode <Ref. to EN(H6DO)(diag)-47, PROCEDURE, Inspection Mode.>.

### WIRING DIAGRAM:

Engine electrical system <Ref. to WI-32, Engine Electrical System.>

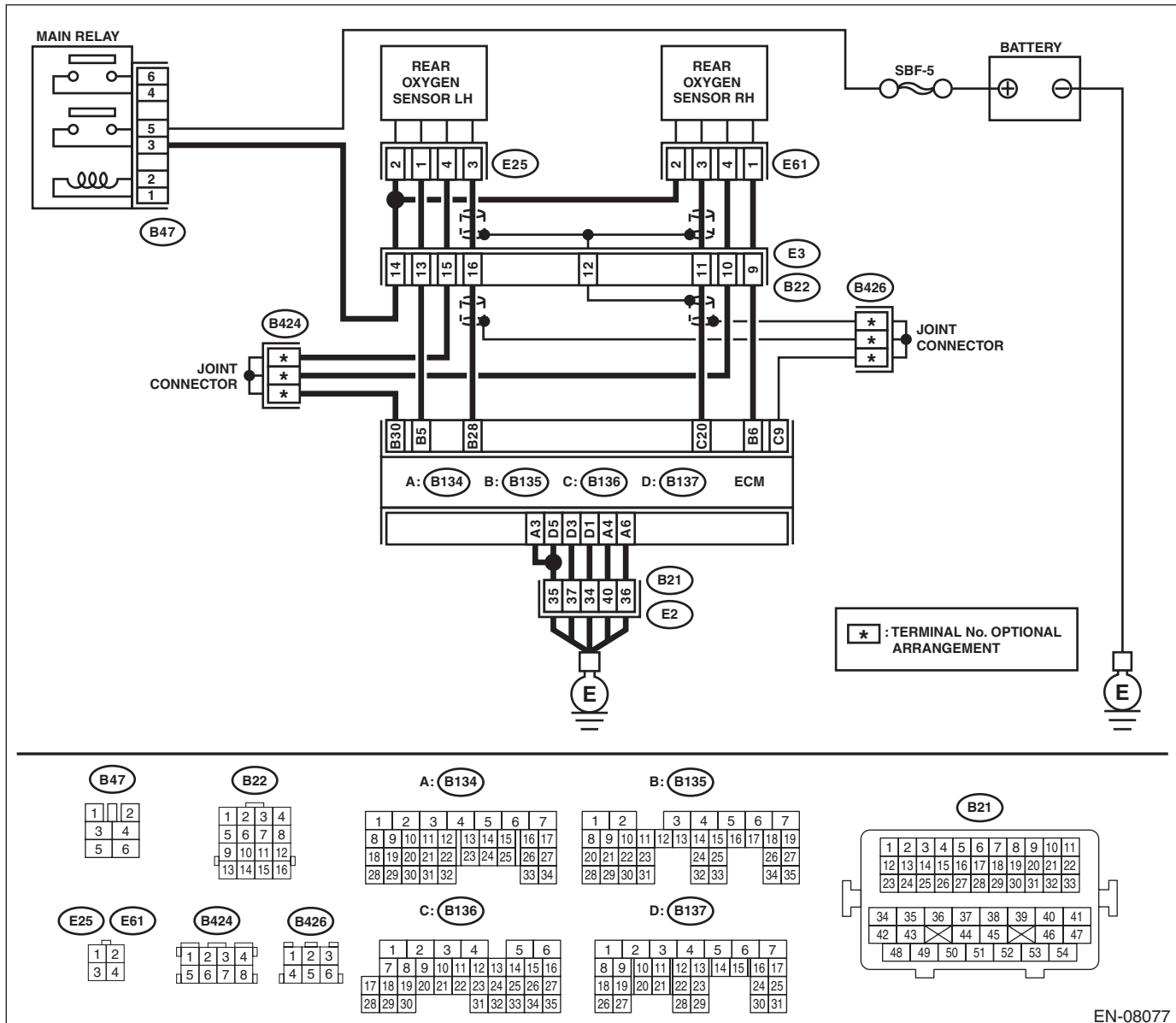

EN-08077

# Diagnostic Procedure with Diagnostic Trouble Code (DTC)

## ENGINE (DIAGNOSTICS)

Step	Check	Yes	No
<p><b>1 CHECK POWER SUPPLY TO REAR OXYGEN SENSOR.</b></p> <p>1) Turn the ignition switch to OFF.                      2) Disconnect the connector from rear oxygen sensor.                      3) Turn the ignition switch to ON.                      4) Measure the voltage between rear oxygen sensor connector and engine ground.</p> <p><b>Connector &amp; terminal</b>  <b>(E25) No. 2 (+) — Engine ground (-):</b></p>	Is the voltage 10 V or more?	Go to step 2.	Repair the power supply line. NOTE: In this case, repair the following item: <ul style="list-style-type: none"> <li>• Open circuit of harness between main relay and rear oxygen sensor connector</li> <li>• Poor contact of main relay connector</li> <li>• Poor contact of coupling connector</li> <li>• Defective main relay</li> </ul>
<p><b>2 CHECK HARNESS BETWEEN ECM AND REAR OXYGEN SENSOR CONNECTOR.</b></p> <p>1) Turn the ignition switch to OFF.                      2) Disconnect the connector from ECM.                      3) Measure the resistance between ECM and oxygen sensor connector.</p> <p><b>Connector &amp; terminal</b>  <b>(B135) No. 5 — (E25) No. 1:</b></p>	Is the resistance less than 1 $\Omega$ ?	Go to step 3.	Repair the harness and connector. NOTE: In this case, repair the following item: <ul style="list-style-type: none"> <li>• Open circuit in harness between ECM and rear oxygen sensor connector</li> <li>• Poor contact of coupling connector</li> </ul>
<p><b>3 CHECK GROUND CIRCUIT FOR ECM.</b></p> <p>Measure the resistance of harness between ECM and chassis ground.</p> <p><b>Connector &amp; terminal</b>  <b>(B134) No. 3 — Chassis ground:</b>  <b>(B134) No. 4 — Chassis ground:</b>  <b>(B134) No. 6 — Chassis ground:</b>  <b>(B137) No. 1 — Chassis ground:</b>  <b>(B137) No. 3 — Chassis ground:</b>  <b>(B137) No. 5 — Chassis ground:</b></p>	Is the resistance less than 5 $\Omega$ ?	Go to step 4.	Repair the harness and connector. NOTE: In this case, repair the following item: <ul style="list-style-type: none"> <li>• Open circuit of harness between ECM and engine ground</li> <li>• Poor contact of coupling connector</li> </ul>
<p><b>4 CHECK REAR OXYGEN SENSOR.</b></p> <p>Measure the resistance between rear oxygen sensor connector terminals.</p> <p><b>Terminals</b>  <b>No. 2 — No. 1:</b></p>	Is the resistance 5 — 7 $\Omega$ ?	Repair the poor contact of ECM connector.	Replace the rear oxygen sensor. <Ref. to FU(H6DO)-50, Rear Oxygen Sensor.>

# Diagnostic Procedure with Diagnostic Trouble Code (DTC)

ENGINE (DIAGNOSTICS)

## R: DTC P0058 HO2S HEATER CONTROL CIRCUIT HIGH (BANK 2 SENSOR 2)

### DTC DETECTING CONDITION:

- Detected when two consecutive driving cycles with fault occur.
- GENERAL DESCRIPTION <Ref. to GD(H6DO)-29, DTC P0058 HO2S HEATER CONTROL CIRCUIT HIGH (BANK 2 SENSOR 2), Diagnostic Trouble Code (DTC) Detecting Criteria.>

### CAUTION:

After servicing or replacing faulty parts, perform Clear Memory Mode <Ref. to EN(H6DO)(diag)-62, OPERATION, Clear Memory Mode.>, and Inspection Mode <Ref. to EN(H6DO)(diag)-47, PROCEDURE, Inspection Mode.>.

### WIRING DIAGRAM:

Engine electrical system <Ref. to WI-32, Engine Electrical System.>

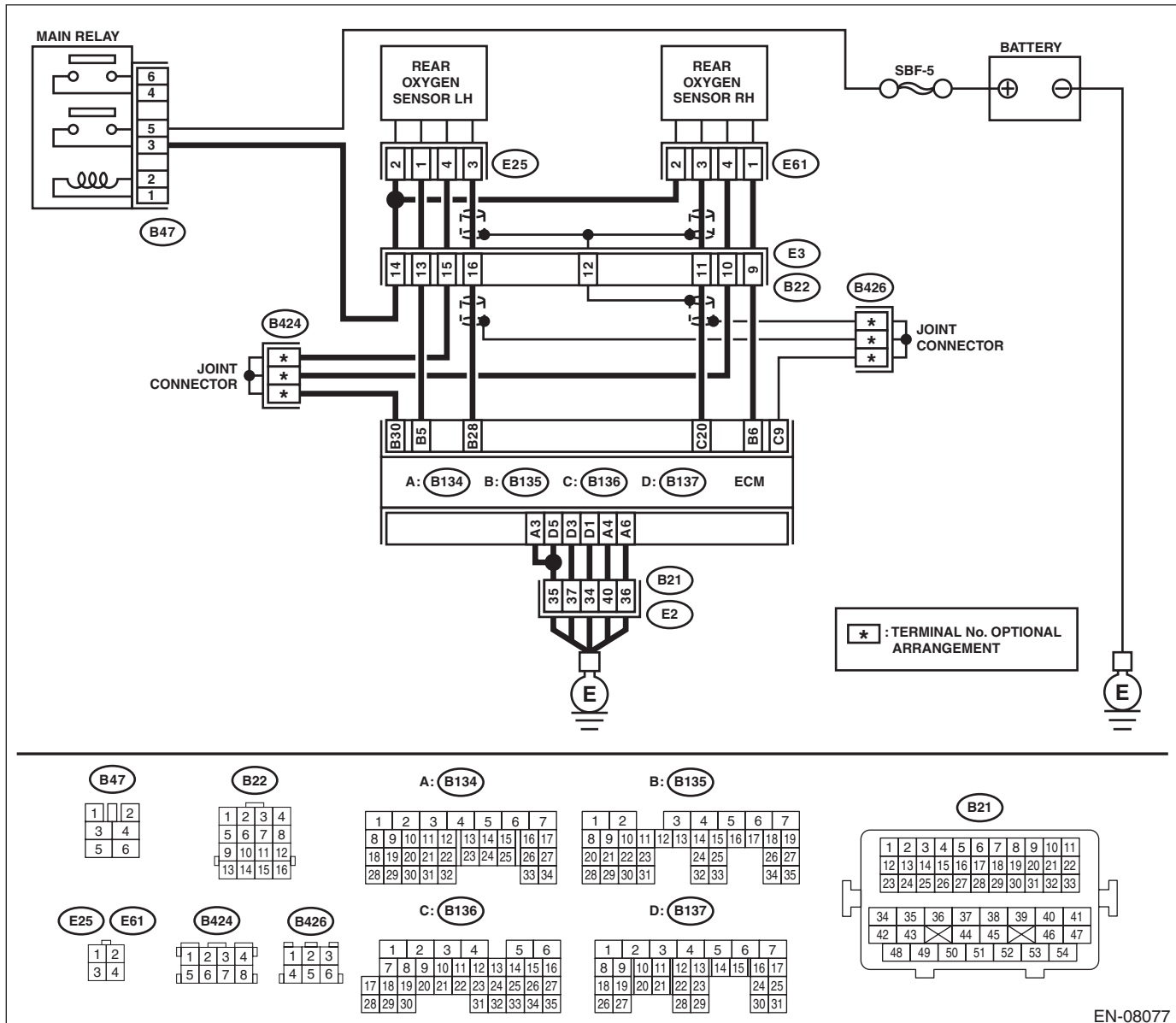

EN-08077

# Diagnostic Procedure with Diagnostic Trouble Code (DTC)

## ENGINE (DIAGNOSTICS)

Step	Check	Yes	No
<b>1 CHECK HARNESS BETWEEN ECM AND REAR OXYGEN SENSOR CONNECTOR.</b> 1) Turn the ignition switch to OFF. 2) Measure the voltage between ECM and chassis ground. <b>Connector &amp; terminal</b> <b>(B135) No. 5 (+) — Chassis ground (-):</b>	Is the voltage 10 V or more?	Repair the short circuit to power in the harness between ECM and rear oxygen sensor connector.	Go to step 2.
<b>2 CHECK GROUND CIRCUIT FOR ECM.</b> 1) Disconnect the connector from ECM. 2) Measure the resistance between ECM and chassis ground. <b>Connector &amp; terminal</b> <b>(B134) No. 3 — Chassis ground:</b> <b>(B134) No. 4 — Chassis ground:</b> <b>(B134) No. 6 — Chassis ground:</b> <b>(B137) No. 1 — Chassis ground:</b> <b>(B137) No. 3 — Chassis ground:</b> <b>(B137) No. 5 — Chassis ground:</b>	Is the resistance less than 5 $\Omega$ ?	Repair the poor contact of ECM connector.	Repair the harness and connector. <b>NOTE:</b> In this case, repair the following item: <ul style="list-style-type: none"> <li>• Open circuit of harness between ECM and engine ground</li> <li>• Poor contact of coupling connector</li> </ul>

# Diagnostic Procedure with Diagnostic Trouble Code (DTC)

ENGINE (DIAGNOSTICS)

## S: DTC P0068 MAP/MAF - THROTTLE POSITION CORRELATION

### DTC DETECTING CONDITION:

- Detected when two consecutive driving cycles with fault occur.
- GENERAL DESCRIPTION <Ref. to GD(H6DO)-30, DTC P0068 MAP/MAF - THROTTLE POSITION CORRELATION, Diagnostic Trouble Code (DTC) Detecting Criteria.>

### CAUTION:

After servicing or replacing faulty parts, perform Clear Memory Mode <Ref. to EN(H6DO)(diag)-62, OPERATION, Clear Memory Mode.>, and Inspection Mode <Ref. to EN(H6DO)(diag)-47, PROCEDURE, Inspection Mode.>.

Step	Check	Yes	No
1 <b>CHECK AIR INTAKE SYSTEM.</b>	Are there holes, loose bolts or disconnection of hose on air intake system?	Repair the air intake system.	Go to step 2.
2 <b>CHECK MANIFOLD ABSOLUTE PRESSURE SENSOR.</b> 1) Start the engine and warm up engine until coolant temperature is higher than 75°C (167°F). 2) Place the select lever in "P" range or "N" range. 3) Turn the A/C switch to OFF. 4) Turn all the accessory switches to OFF. 5) Read the value of «Mani. Absolute Pressure» using the Subaru Select Monitor or a general scan tool. <b>NOTE:</b> • Subaru Select Monitor For detailed operation procedures, refer to "READ CURRENT DATA FOR ENGINE". <Ref. to EN(H6DO)(diag)-37, Subaru Select Monitor.> • General scan tool For detailed operation procedures, refer to the "General Scan Tool Instruction Manual".	Is the value in «Mani. Absolute Pressure» 73.3 — 106.6 kPa (550 — 800 mmHg, 21.65 — 31.50 inHg) when the ignition is turned ON, and 20.0 — 46.7 kPa (150 — 350 mmHg, 5.91 — 13.78 inHg) during idling?	Go to step 3.	Replace the manifold absolute pressure sensor. <Ref. to FU(H6DO)-39, Manifold Absolute Pressure Sensor.>
3 <b>CHECK THROTTLE OPENING ANGLE.</b> Using the Subaru Select Monitor or a general scan tool, read the value in «Throttle Opening Angle». <b>NOTE:</b> • Subaru Select Monitor For detailed operation procedures, refer to "READ CURRENT DATA FOR ENGINE". <Ref. to EN(H6DO)(diag)-37, Subaru Select Monitor.> • General scan tool For detailed operation procedures, refer to the "General Scan Tool Instruction Manual".	Is the value in «Throttle Opening Angle» with the throttle fully closed less than 5%?	Go to step 4.	Replace the electronic throttle control. <Ref. to FU(H6DO)-19, Throttle Body.>
4 <b>CHECK THROTTLE OPENING ANGLE.</b>	Is the value in «Throttle Opening Angle» with the throttle fully open 85% or more?	Replace the manifold absolute pressure sensor. <Ref. to FU(H6DO)-39, Manifold Absolute Pressure Sensor.>	Replace the electronic throttle control. <Ref. to FU(H6DO)-19, Throttle Body.>

# Diagnostic Procedure with Diagnostic Trouble Code (DTC)

ENGINE (DIAGNOSTICS)

## T: DTC P0101 MASS OR VOLUME AIR FLOW CIRCUIT RANGE/PERFORMANCE

### DTC DETECTING CONDITION:

- Detected when two consecutive driving cycles with fault occur.
- GENERAL DESCRIPTION <Ref. to GD(H6DO)-32, DTC P0101 MASS OR VOLUME AIR FLOW CIRCUIT RANGE/PERFORMANCE, Diagnostic Trouble Code (DTC) Detecting Criteria.>

### TROUBLE SYMPTOM:

- Improper idling
- Engine stalls.
- Poor driving performance

### CAUTION:

After servicing or replacing faulty parts, perform Clear Memory Mode <Ref. to EN(H6DO)(diag)-62, OPERATION, Clear Memory Mode.>, and Inspection Mode <Ref. to EN(H6DO)(diag)-47, PROCEDURE, Inspection Mode.>.

Step	Check	Yes	No
1 CHECK FOR ANY OTHER DTC ON DISPLAY.	Is any other DTC displayed?	Check the appropriate DTC using the "List of Diagnostic Trouble Code (DTC)". <Ref. to EN(H6DO)(diag)-89, List of Diagnostic Trouble Code (DTC).>	Replace the mass air flow and intake air temperature sensor. <Ref. to FU(H6DO)-40, Mass Air Flow and Intake Air Temperature Sensor.>

# Diagnostic Procedure with Diagnostic Trouble Code (DTC)

ENGINE (DIAGNOSTICS)

## U: DTC P0102 MASS OR VOLUME AIR FLOW CIRCUIT LOW INPUT

### DTC DETECTING CONDITION:

- Immediately at fault recognition
- GENERAL DESCRIPTION <Ref. to GD(H6DO)-34, DTC P0102 MASS OR VOLUME AIR FLOW CIRCUIT LOW INPUT, Diagnostic Trouble Code (DTC) Detecting Criteria.>

### TROUBLE SYMPTOM:

- Improper idling
- Engine stalls.
- Poor driving performance

### CAUTION:

After servicing or replacing faulty parts, perform Clear Memory Mode <Ref. to EN(H6DO)(diag)-62, OPERATION, Clear Memory Mode.>, and Inspection Mode <Ref. to EN(H6DO)(diag)-47, PROCEDURE, Inspection Mode.>.

### WIRING DIAGRAM:

Engine electrical system <Ref. to WI-32, Engine Electrical System.>

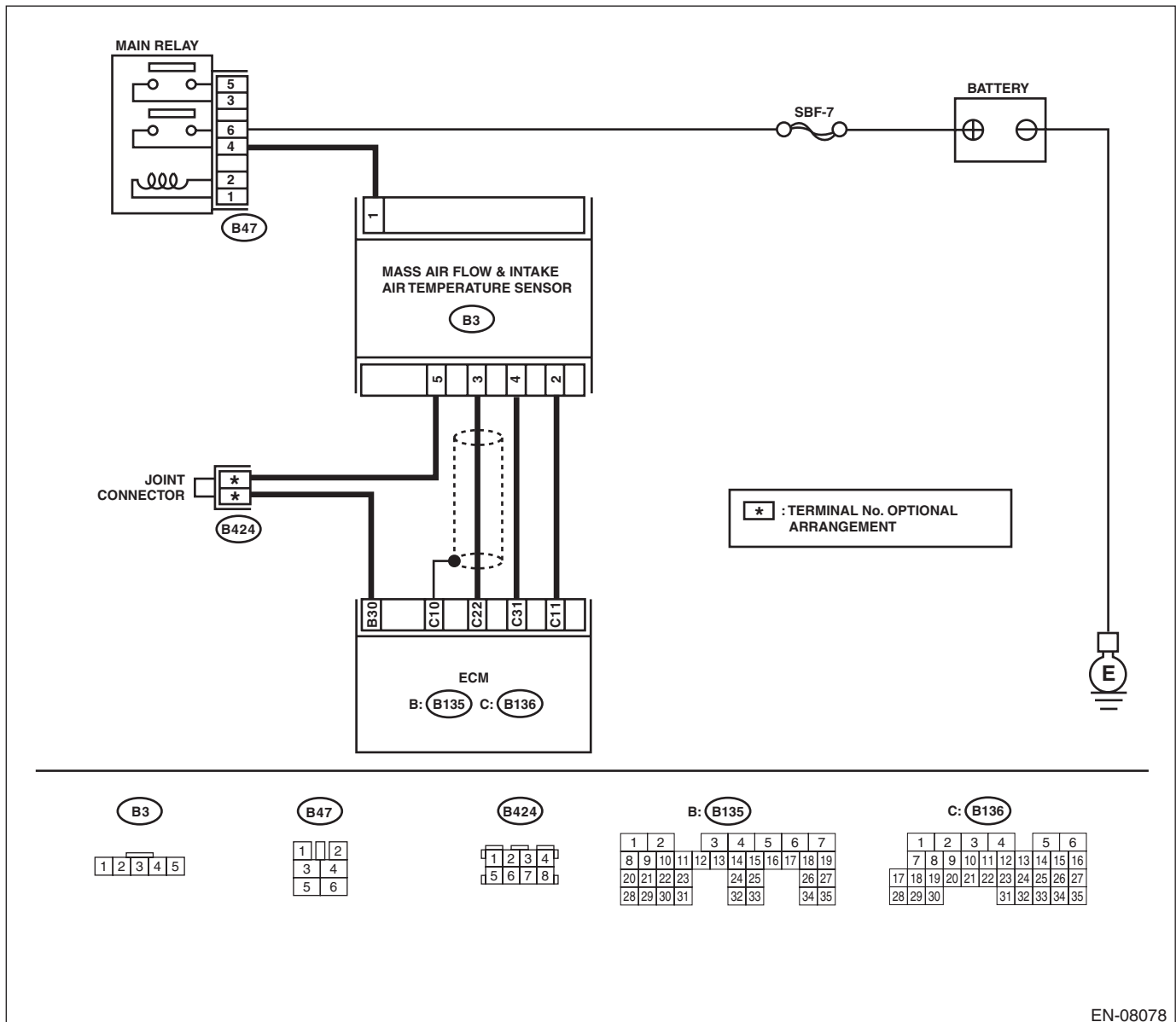

EN-08078

# Diagnostic Procedure with Diagnostic Trouble Code (DTC)

## ENGINE (DIAGNOSTICS)

Step	Check	Yes	No
<p><b>1</b>      <b>CHECK CURRENT DATA.</b>            1) Start the engine.            2) Read the value of «Air Flow Sensor Voltage» using Subaru Select Monitor.            NOTE:            For detailed operation procedures, refer to “READ CURRENT DATA FOR ENGINE”. &lt;Ref. to EN(H6DO)(diag)-37, Subaru Select Monitor.&gt;</p>	<p>Is the value of «Air Flow Sensor Voltage» less than 0.2 V?</p>	<p>Go to step 2.</p>	<p>Even if DTC is detected, the circuit has returned to a normal condition at this time. Reproduce the failure, and then perform the diagnosis again.            NOTE:            In this case, temporary poor contact of connector, temporary open or short circuit of harness may be the cause.</p>
<p><b>2</b>      <b>CHECK POWER SUPPLY OF MASS AIR FLOW AND INTAKE AIR TEMPERATURE SENSOR.</b>            1) Turn the ignition switch to OFF.            2) Disconnect the connectors from the mass air flow and intake air temperature sensor.            3) Turn the ignition switch to ON.            4) Measure the voltage between mass air flow and intake air temperature sensor connector and engine ground.  <b>Connector &amp; terminal</b>  <b>(B3) No. 1 (+) — Engine ground (-):</b></p>	<p>Is the voltage 10 V or more?</p>	<p>Go to step 3.</p>	<p>Repair the harness and connector.            NOTE:            In this case, repair the following item:            • Open circuit in harness between main relay and mass air flow and intake air temperature sensor connector            • Poor contact of main relay connector</p>
<p><b>3</b>      <b>CHECK HARNESS BETWEEN ECM AND MASS AIR FLOW AND INTAKE AIR TEMPERATURE SENSOR CONNECTOR.</b>            1) Turn the ignition switch to OFF.            2) Disconnect the connector from ECM.            3) Measure the resistance of harness between ECM and the mass air flow and intake air temperature sensor connector.  <b>Connector &amp; terminal</b>  <b>(B136) No. 22 — (B3) No. 3:</b></p>	<p>Is the resistance less than 1 Ω?</p>	<p>Go to step 4.</p>	<p>Repair the open circuit in harness between ECM and the mass air flow and intake air temperature sensor connector.</p>
<p><b>4</b>      <b>CHECK HARNESS BETWEEN ECM AND MASS AIR FLOW AND INTAKE AIR TEMPERATURE SENSOR CONNECTOR.</b>            Measure the resistance between ECM and chassis ground.  <b>Connector &amp; terminal</b>  <b>(B136) No. 22 — Chassis ground:</b></p>	<p>Is the resistance 1 MΩ or more?</p>	<p>Go to step 5.</p>	<p>Repair the short circuit to ground in harness between ECM and mass air flow and intake air temperature sensor connector.</p>
<p><b>5</b>      <b>CHECK FOR POOR CONTACT.</b>            Check for poor contact of ECM and mass air flow and intake air temperature sensor connector.</p>	<p>Is there poor contact of ECM or mass air flow and intake air temperature sensor connector?</p>	<p>Repair the poor contact of ECM or mass air flow and intake air temperature sensor connector.</p>	<p>Replace the mass air flow and intake air temperature sensor. &lt;Ref. to FU(H6DO)-40, Mass Air Flow and Intake Air Temperature Sensor.&gt;</p>



# Diagnostic Procedure with Diagnostic Trouble Code (DTC)

ENGINE (DIAGNOSTICS)

## V: DTC P0103 MASS OR VOLUME AIR FLOW CIRCUIT HIGH INPUT

### DTC DETECTING CONDITION:

- Immediately at fault recognition
- GENERAL DESCRIPTION <Ref. to GD(H6DO)-36, DTC P0103 MASS OR VOLUME AIR FLOW CIRCUIT HIGH INPUT, Diagnostic Trouble Code (DTC) Detecting Criteria.>

### TROUBLE SYMPTOM:

- Improper idling
- Engine stalls.
- Poor driving performance

### CAUTION:

After servicing or replacing faulty parts, perform Clear Memory Mode <Ref. to EN(H6DO)(diag)-62, OPERATION, Clear Memory Mode.>, and Inspection Mode <Ref. to EN(H6DO)(diag)-47, PROCEDURE, Inspection Mode.>.

### WIRING DIAGRAM:

Engine electrical system <Ref. to WI-32, Engine Electrical System.>

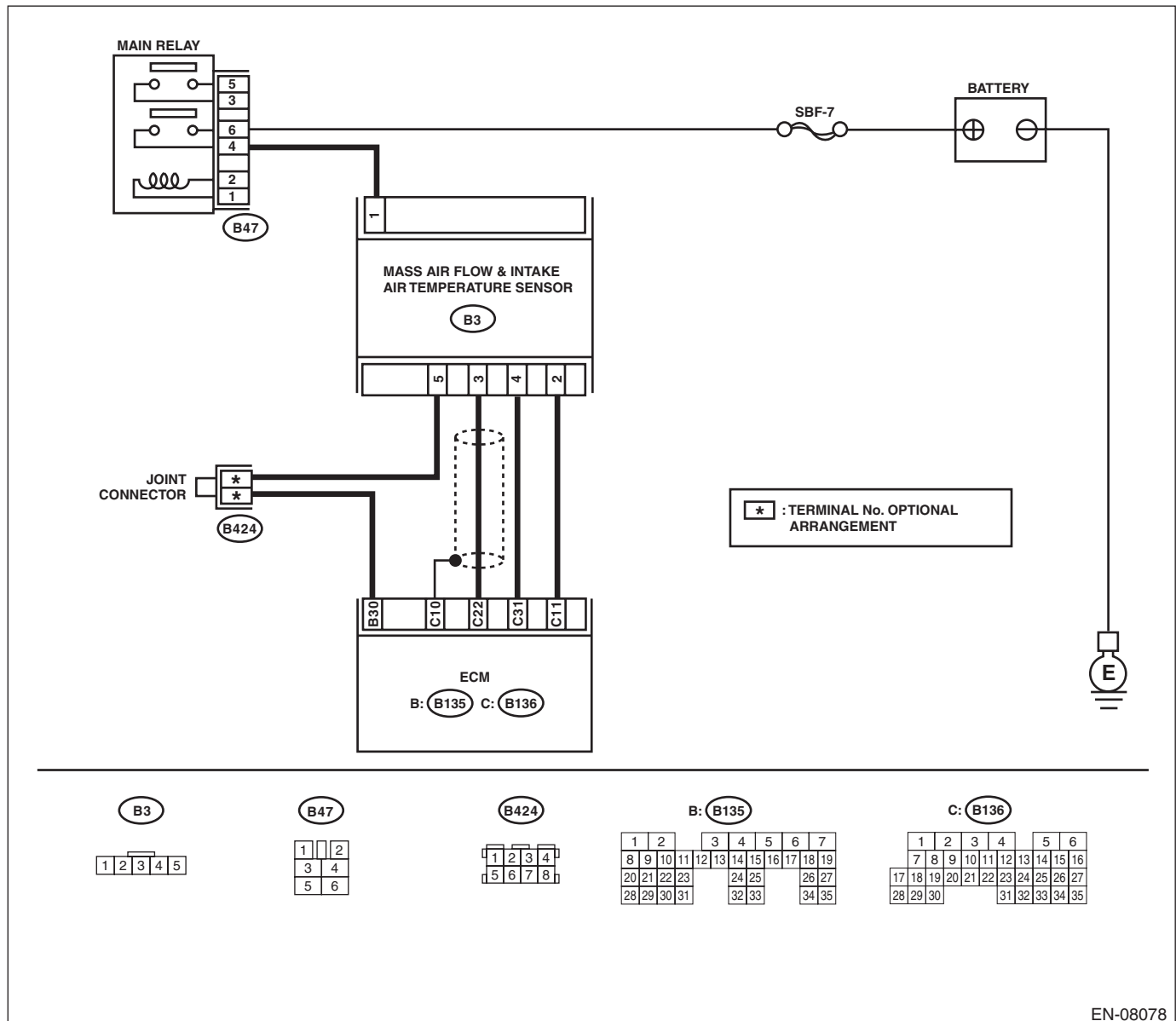

EN-08078

# Diagnostic Procedure with Diagnostic Trouble Code (DTC)

## ENGINE (DIAGNOSTICS)

Step	Check	Yes	No
<p><b>1</b></p> <p><b>CHECK CURRENT DATA.</b></p> <p>1) Start the engine.</p> <p>2) Read the value of «Air Flow Sensor Voltage» using Subaru Select Monitor.</p> <p>NOTE: For detailed operation procedures, refer to “READ CURRENT DATA FOR ENGINE”. &lt;Ref. to EN(H6DO)(diag)-37, Subaru Select Monitor.&gt;</p>	<p>Is the value of «Air Flow Sensor Voltage» 5 V or more?</p>	<p>Go to step 2.</p>	<p>Even if DTC is detected, the circuit has returned to a normal condition at this time. Reproduce the failure, and then perform the diagnosis again.</p> <p>NOTE: In this case, temporary poor contact of connector, temporary open or short circuit of harness may be the cause.</p>
<p><b>2</b></p> <p><b>CHECK HARNESS BETWEEN ECM AND MASS AIR FLOW AND INTAKE AIR TEMPERATURE SENSOR CONNECTOR.</b></p> <p>1) Turn the ignition switch to OFF.</p> <p>2) Disconnect the connectors from the mass air flow and intake air temperature sensor.</p> <p>3) Start the engine.</p> <p>4) Read the value of «Air Flow Sensor Voltage» using Subaru Select Monitor.</p> <p>NOTE: For detailed operation procedures, refer to “READ CURRENT DATA FOR ENGINE”. &lt;Ref. to EN(H6DO)(diag)-37, Subaru Select Monitor.&gt;</p>	<p>Is the value of «Air Flow Sensor Voltage» 5 V or more?</p>	<p>Repair the short circuit of harness to power supply between ECM and mass air flow and intake air temperature sensor connector.</p>	<p>Go to step 3.</p>
<p><b>3</b></p> <p><b>CHECK HARNESS BETWEEN ECM AND MASS AIR FLOW AND INTAKE AIR TEMPERATURE SENSOR CONNECTOR.</b></p> <p>1) Turn the ignition switch to OFF.</p> <p>2) Measure the resistance of harness between mass air flow and intake air temperature sensor connector and engine ground.</p> <p><b>Connector &amp; terminal</b> <b>(B3) No. 2 — Engine ground:</b></p>	<p>Is the resistance less than 5 Ω?</p>	<p>Go to step 4.</p>	<p>Repair the harness and connector.</p> <p>NOTE: In this case, repair the following item:</p> <ul style="list-style-type: none"> <li>• Open circuit in harness between ECM and mass air flow and intake air temperature sensor connector</li> <li>• Poor contact of ECM connector</li> </ul>
<p><b>4</b></p> <p><b>CHECK FOR POOR CONTACT.</b></p> <p>Check for poor contact of mass air flow and intake air temperature sensor connector.</p>	<p>Is there poor contact of mass air flow and intake air temperature sensor connector?</p>	<p>Repair the poor contact of mass air flow and intake air temperature sensor connector.</p>	<p>Replace the mass air flow and intake air temperature sensor. &lt;Ref. to FU(H6DO)-40, Mass Air Flow and Intake Air Temperature Sensor.&gt;</p>

# Diagnostic Procedure with Diagnostic Trouble Code (DTC)

ENGINE (DIAGNOSTICS)

## W: DTC P0107 MANIFOLD ABSOLUTE PRESSURE/BAROMETRIC PRESSURE CIRCUIT LOW INPUT

### DTC DETECTING CONDITION:

- Immediately at fault recognition
- GENERAL DESCRIPTION <Ref. to GD(H6DO)-38, DTC P0107 MANIFOLD ABSOLUTE PRESSURE/BAROMETRIC PRESSURE CIRCUIT LOW INPUT, Diagnostic Trouble Code (DTC) Detecting Criteria.>

### CAUTION:

After servicing or replacing faulty parts, perform Clear Memory Mode <Ref. to EN(H6DO)(diag)-62, OPERATION, Clear Memory Mode.>, and Inspection Mode <Ref. to EN(H6DO)(diag)-47, PROCEDURE, Inspection Mode.>.

### WIRING DIAGRAM:

Engine electrical system <Ref. to WI-32, Engine Electrical System.>

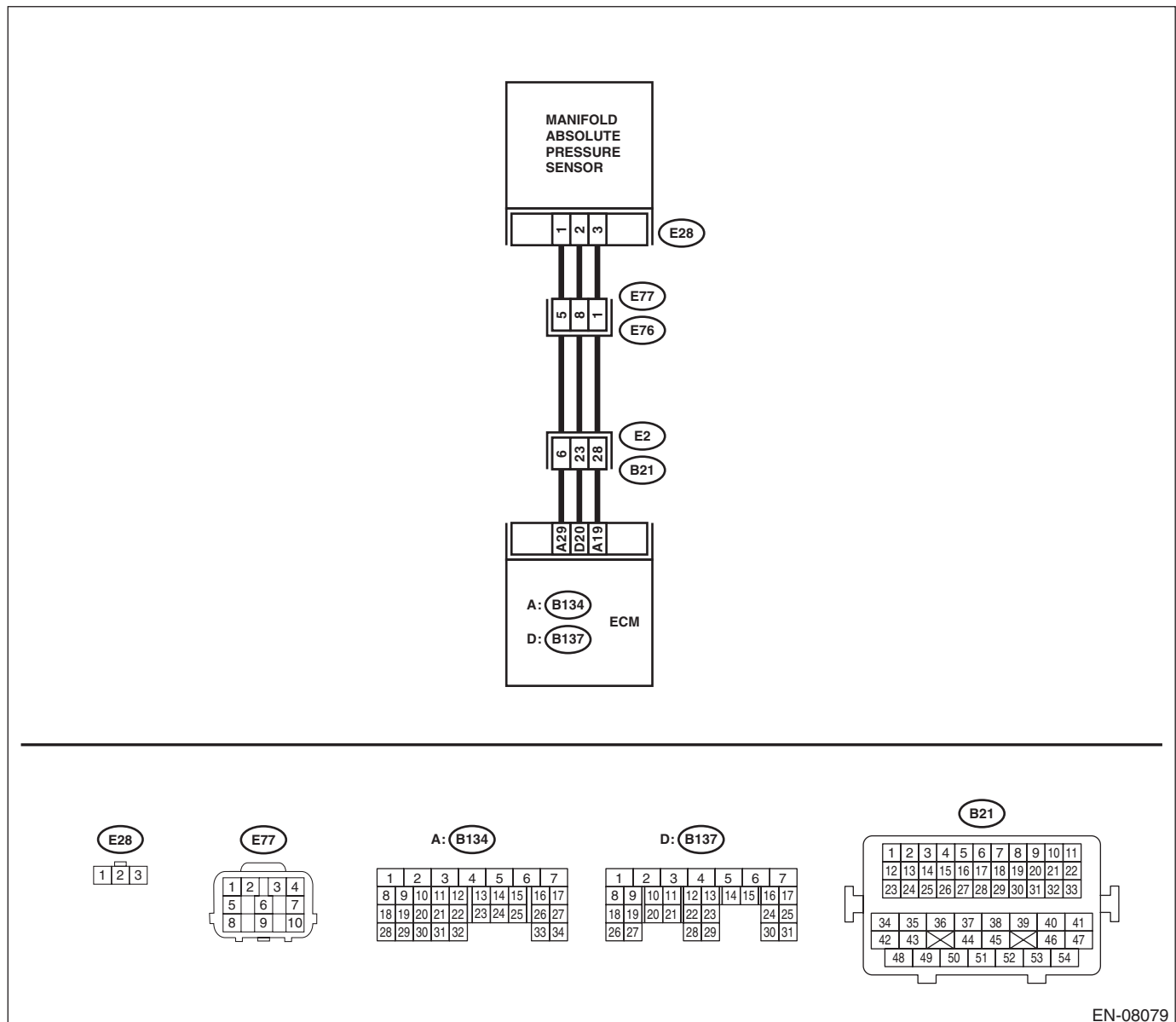

EN-08079

# Diagnostic Procedure with Diagnostic Trouble Code (DTC)

## ENGINE (DIAGNOSTICS)

	Step	Check	Yes	No
1	<p><b>CHECK CURRENT DATA.</b></p> <p>1) Start the engine.</p> <p>2) Read the value of «Mani. Absolute Pressure» using the Subaru Select Monitor or a general scan tool.</p> <p>NOTE:</p> <ul style="list-style-type: none"> <li>Subaru Select Monitor</li> </ul> <p>For detailed operation procedures, refer to "READ CURRENT DATA FOR ENGINE". &lt;Ref. to EN(H6DO)(diag)-37, Subaru Select Monitor.&gt;</p> <ul style="list-style-type: none"> <li>General scan tool</li> </ul> <p>For detailed operation procedures, refer to the general scan tool operation manual.</p>	Is the value of «Mani. Absolute Pressure» less than 13.3 kPa (100 mmHg, 3.94 inHg)?	Go to step 2.	<p>Even if DTC is detected, the circuit has returned to a normal condition at this time. Reproduce the failure, and then perform the diagnosis again.</p> <p>NOTE:</p> <p>In this case, temporary poor contact of connector, temporary open or short circuit of harness may be the cause.</p>
2	<p><b>CHECK POWER SUPPLY OF MANIFOLD ABSOLUTE PRESSURE SENSOR.</b></p> <p>1) Turn the ignition switch to OFF.</p> <p>2) Disconnect the connector from manifold absolute pressure sensor.</p> <p>3) Turn the ignition switch to ON.</p> <p>4) Measure the voltage between manifold absolute pressure sensor connector and engine ground.</p> <p><b>Connector &amp; terminal</b> <b>(E28) No. 3 (+) — Engine ground (-):</b></p>	Is the voltage 4.5 V or more?	Go to step 3.	<p>Repair the harness and connector.</p> <p>NOTE:</p> <p>In this case, repair the following item:</p> <ul style="list-style-type: none"> <li>Open circuit of harness between ECM and manifold absolute pressure sensor connector</li> <li>Poor contact of ECM connector</li> <li>Poor contact of coupling connector</li> </ul>
3	<p><b>CHECK HARNESS BETWEEN ECM AND MANIFOLD ABSOLUTE PRESSURE SENSOR CONNECTOR.</b></p> <p>1) Turn the ignition switch to OFF.</p> <p>2) Disconnect the connector from ECM.</p> <p>3) Measure the resistance of harness between ECM and manifold absolute pressure sensor connector.</p> <p><b>Connector &amp; terminal</b> <b>(B137) No. 20 — (E28) No. 2:</b></p>	Is the resistance less than 1 Ω?	Go to step 4.	<p>Repair the harness and connector.</p> <p>NOTE:</p> <p>In this case, repair the following item:</p> <ul style="list-style-type: none"> <li>Open circuit of harness between ECM and manifold absolute pressure sensor connector</li> <li>Poor contact of coupling connector</li> </ul>
4	<p><b>CHECK HARNESS BETWEEN ECM AND MANIFOLD ABSOLUTE PRESSURE SENSOR CONNECTOR.</b></p> <p>Measure the resistance between ECM and chassis ground.</p> <p><b>Connector &amp; terminal</b> <b>(B137) No. 20 — Chassis ground:</b></p>	Is the resistance 1 MΩ or more?	Go to step 5.	<p>Repair ground short circuit of harness between ECM and manifold absolute pressure sensor connector.</p>
5	<p><b>CHECK FOR POOR CONTACT.</b></p> <p>Check for poor contact of ECM and manifold absolute pressure sensor connector.</p>	Is there poor contact of ECM or manifold absolute pressure sensor connector?	Repair the poor contact of ECM or manifold absolute pressure sensor connector.	<p>Replace the manifold absolute pressure sensor. &lt;Ref. to FU(H6DO)-39, Manifold Absolute Pressure Sensor.&gt;</p>

# Diagnostic Procedure with Diagnostic Trouble Code (DTC)

ENGINE (DIAGNOSTICS)

## X: DTC P0108 MANIFOLD ABSOLUTE PRESSURE/BAROMETRIC PRESSURE CIRCUIT HIGH INPUT

### DTC DETECTING CONDITION:

- Immediately at fault recognition
- GENERAL DESCRIPTION <Ref. to GD(H6DO)-40, DTC P0108 MANIFOLD ABSOLUTE PRESSURE/BAROMETRIC PRESSURE CIRCUIT HIGH INPUT, Diagnostic Trouble Code (DTC) Detecting Criteria.>

### CAUTION:

After servicing or replacing faulty parts, perform Clear Memory Mode <Ref. to EN(H6DO)(diag)-62, OPERATION, Clear Memory Mode.>, and Inspection Mode <Ref. to EN(H6DO)(diag)-47, PROCEDURE, Inspection Mode.>.

### WIRING DIAGRAM:

Engine electrical system <Ref. to WI-32, Engine Electrical System.>

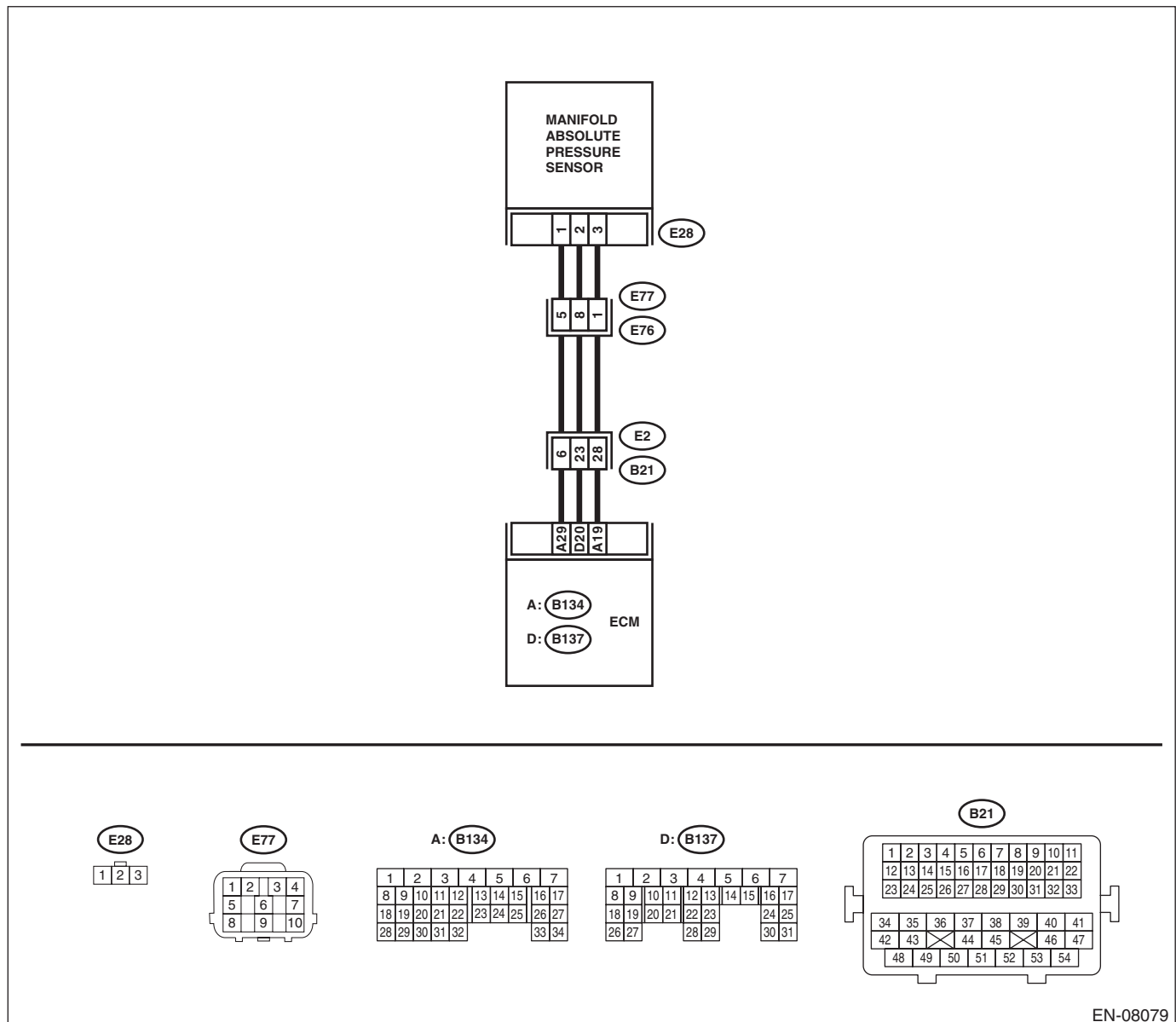

EN-08079

# Diagnostic Procedure with Diagnostic Trouble Code (DTC)

## ENGINE (DIAGNOSTICS)

Step	Check	Yes	No
<p><b>1 CHECK CURRENT DATA.</b></p> <p>1) Start the engine.</p> <p>2) Read the value of «Mani. Absolute Pressure» using the Subaru Select Monitor or a general scan tool.</p> <p>NOTE:</p> <ul style="list-style-type: none"> <li>• Subaru Select Monitor</li> </ul> <p>For detailed operation procedures, refer to "READ CURRENT DATA FOR ENGINE". &lt;Ref. to EN(H6DO)(diag)-37, Subaru Select Monitor.&gt;</p> <ul style="list-style-type: none"> <li>• General scan tool</li> </ul> <p>For detailed operation procedures, refer to the general scan tool operation manual.</p>	<p>Is the value of «Mani. Absolute Pressure» 119.5 kPa (896.5 mmHg, 35.29 inHg) or more?</p>	<p>Go to step 2.</p>	<p>Even if DTC is detected, the circuit has returned to a normal condition at this time. Reproduce the failure, and then perform the diagnosis again.</p> <p>NOTE:</p> <p>In this case, temporary poor contact of connector, temporary open or short circuit of harness may be the cause.</p>
<p><b>2 CHECK HARNESS BETWEEN ECM AND MANIFOLD ABSOLUTE PRESSURE SENSOR CONNECTOR.</b></p> <p>1) Turn the ignition switch to OFF.</p> <p>2) Disconnect the connector from manifold absolute pressure sensor.</p> <p>3) Start the engine.</p> <p>4) Read the value of «Mani. Absolute Pressure» using the Subaru Select Monitor or a general scan tool.</p> <p>NOTE:</p> <ul style="list-style-type: none"> <li>• Subaru Select Monitor</li> </ul> <p>For detailed operation procedures, refer to "READ CURRENT DATA FOR ENGINE". &lt;Ref. to EN(H6DO)(diag)-37, Subaru Select Monitor.&gt;</p> <ul style="list-style-type: none"> <li>• General scan tool</li> </ul> <p>For detailed operation procedures, refer to the general scan tool operation manual.</p>	<p>Is the value of «Mani. Absolute Pressure» 119.5 kPa (896.5 mmHg, 35.29 inHg) or more?</p>	<p>Repair the short circuit to power in harness between ECM and manifold absolute pressure sensor connector.</p>	<p>Go to step 3.</p>
<p><b>3 CHECK HARNESS BETWEEN ECM AND MANIFOLD ABSOLUTE PRESSURE SENSOR CONNECTOR.</b></p> <p>1) Turn the ignition switch to OFF.</p> <p>2) Measure the resistance of harness between manifold absolute pressure sensor connector and engine ground.</p> <p><b>Connector &amp; terminal</b> <b>(E28) No. 1 — Engine ground:</b></p>	<p>Is the resistance less than 5 Ω?</p>	<p>Go to step 4.</p>	<p>Repair the harness and connector.</p> <p>NOTE:</p> <p>In this case, repair the following item:</p> <ul style="list-style-type: none"> <li>• Open circuit of harness between ECM and manifold absolute pressure sensor connector</li> <li>• Poor contact of ECM connector</li> <li>• Poor contact of coupling connector</li> </ul>
<p><b>4 CHECK FOR POOR CONTACT.</b></p> <p>Check for poor contact of manifold absolute pressure sensor connector.</p>	<p>Is there poor contact of manifold absolute pressure sensor connector?</p>	<p>Repair the poor contact of manifold absolute pressure sensor connector.</p>	<p>Replace the manifold absolute pressure sensor. &lt;Ref. to FU(H6DO)-39, Manifold Absolute Pressure Sensor.&gt;</p>

# Diagnostic Procedure with Diagnostic Trouble Code (DTC)

ENGINE (DIAGNOSTICS)

## Y: DTC P0111 INTAKE AIR TEMPERATURE SENSOR RANGE/PERFORMANCE PROBLEM

### DTC DETECTING CONDITION:

- Detected when two consecutive driving cycles with fault occur.
- GENERAL DESCRIPTION <Ref. to GD(H6DO)-42, DTC P0111 INTAKE AIR TEMPERATURE SENSOR RANGE/PERFORMANCE PROBLEM, Diagnostic Trouble Code (DTC) Detecting Criteria.>

### TROUBLE SYMPTOM:

- Improper idling
- Poor driving performance

### CAUTION:

After servicing or replacing faulty parts, perform Clear Memory Mode <Ref. to EN(H6DO)(diag)-62, OPERATION, Clear Memory Mode.>, and Inspection Mode <Ref. to EN(H6DO)(diag)-47, PROCEDURE, Inspection Mode.>.

	Step	Check	Yes	No
1	<p><b>CHECK ENGINE COOLANT TEMPERATURE.</b></p> <p>1) Start the engine and warm up completely.</p> <p>2) Using the Subaru Select Monitor or a general scan tool, measure the value in «Coolant Temp.».</p> <p>NOTE:</p> <ul style="list-style-type: none"><li>• Subaru Select Monitor</li></ul> <p>For detailed operation procedures, refer to “READ CURRENT DATA FOR ENGINE”. &lt;Ref. to EN(H6DO)(diag)-37, Subaru Select Monitor.&gt;</p> <ul style="list-style-type: none"><li>• General scan tool</li></ul> <p>For detailed operation procedures, refer to the general scan tool operation manual.</p>	<p>Is the value of «Coolant Temp.» 75°C (167°F) or more?</p>	<p>Replace the mass air flow and intake air temperature sensor. &lt;Ref. to FU(H6DO)-40, Mass Air Flow and Intake Air Temperature Sensor.&gt;</p>	<p>Check for DTC P0125. &lt;Ref. to EN(H6DO)(diag)-151, DTC P0125 INSUFFICIENT COOLANT TEMPERATURE FOR CLOSED LOOP FUEL CONTROL, Diagnostic Procedure with Diagnostic Trouble Code (DTC).&gt;</p>

# Diagnostic Procedure with Diagnostic Trouble Code (DTC)

ENGINE (DIAGNOSTICS)

## Z: DTC P0112 INTAKE AIR TEMPERATURE SENSOR 1 CIRCUIT LOW

### DTC DETECTING CONDITION:

- Immediately at fault recognition
- GENERAL DESCRIPTION <Ref. to GD(H6DO)-44, DTC P0112 INTAKE AIR TEMPERATURE SENSOR 1 CIRCUIT LOW, Diagnostic Trouble Code (DTC) Detecting Criteria.>

### TROUBLE SYMPTOM:

- Improper idling
- Poor driving performance

### CAUTION:

After servicing or replacing faulty parts, perform Clear Memory Mode <Ref. to EN(H6DO)(diag)-62, OPERATION, Clear Memory Mode.>, and Inspection Mode <Ref. to EN(H6DO)(diag)-47, PROCEDURE, Inspection Mode.>.

### WIRING DIAGRAM:

Engine electrical system <Ref. to WI-32, Engine Electrical System.>

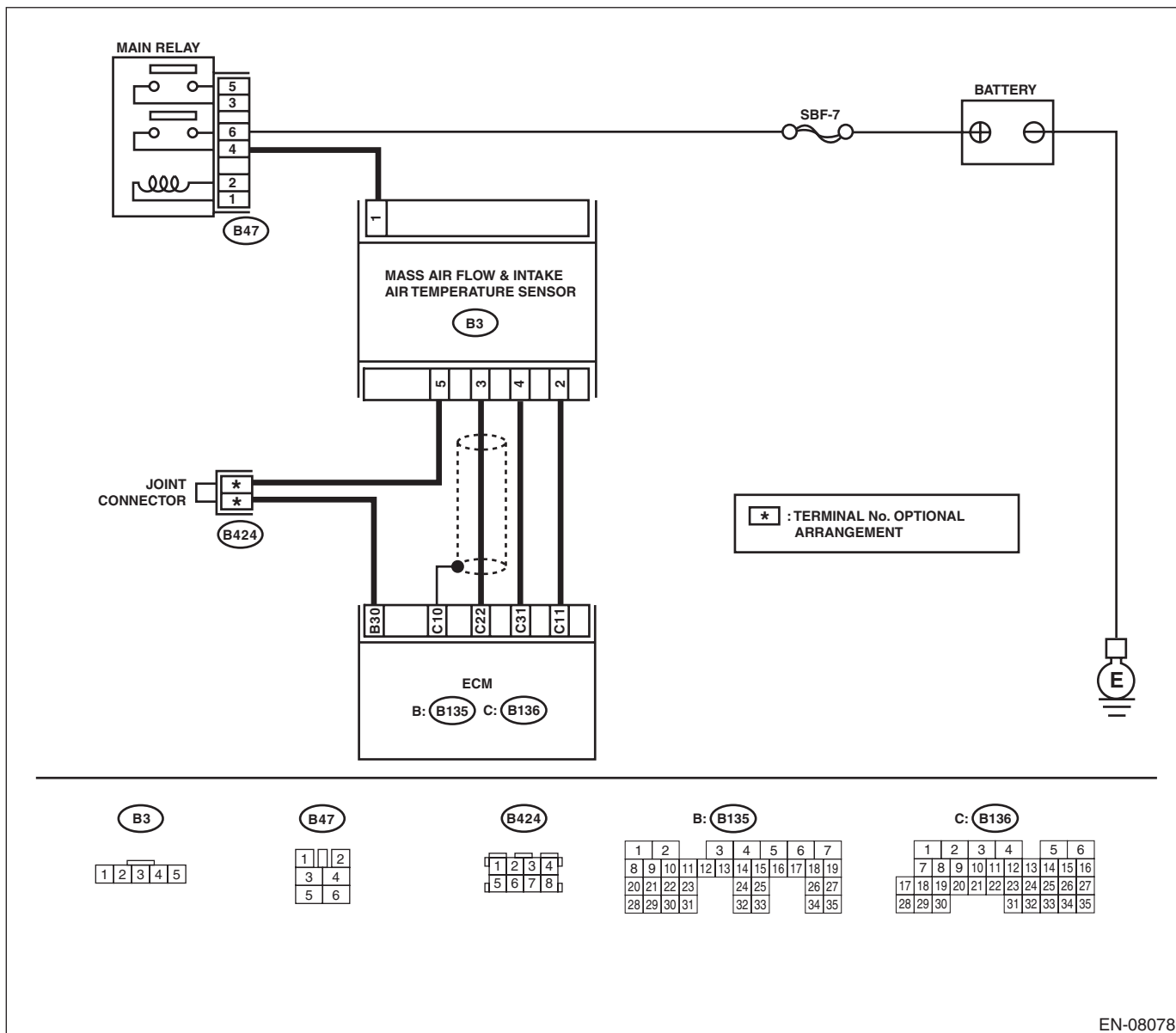

EN-08078



# Diagnostic Procedure with Diagnostic Trouble Code (DTC)

ENGINE (DIAGNOSTICS)

	Step	Check	Yes	No
1	<p><b>CHECK CURRENT DATA.</b></p> <p>1) Start the engine.</p> <p>2) Read the value of «Intake Air Temp.» using the Subaru Select Monitor or a general scan tool.</p> <p>NOTE:</p> <ul style="list-style-type: none"> <li>Subaru Select Monitor</li> </ul> <p>For detailed operation procedures, refer to "READ CURRENT DATA FOR ENGINE". &lt;Ref. to EN(H6DO)(diag)-37, Subaru Select Monitor.&gt;</p> <ul style="list-style-type: none"> <li>General scan tool</li> </ul> <p>For detailed operation procedures, refer to the general scan tool operation manual.</p>	<p>Is the value of «Intake Air Temp.» 120°C (248°F) or more?</p>	<p>Go to step 2.</p>	<p>Even if DTC is detected, the circuit has returned to a normal condition at this time. Reproduce the failure, and then perform the diagnosis again.</p> <p>NOTE:</p> <p>In this case, temporary poor contact of connector, temporary open or short circuit of harness may be the cause.</p>
2	<p><b>CHECK HARNESS BETWEEN ECM AND MASS AIR FLOW AND INTAKE AIR TEMPERATURE SENSOR CONNECTOR.</b></p> <p>1) Turn the ignition switch to OFF.</p> <p>2) Disconnect the connector from ECM and the mass air flow and intake air temperature sensor.</p> <p>3) Measure the resistance between ECM and chassis ground.</p> <p><b>Connector &amp; terminal</b> <b>(B136) No. 31 — Chassis ground:</b></p>	<p>Is the resistance 1 MΩ or more?</p>	<p>Replace the mass air flow and intake air temperature sensor. &lt;Ref. to FU(H6DO)-40, Mass Air Flow and Intake Air Temperature Sensor.&gt;</p>	<p>Repair the short circuit to ground in harness between ECM and mass air flow and intake air temperature sensor connector.</p>

# Diagnostic Procedure with Diagnostic Trouble Code (DTC)

ENGINE (DIAGNOSTICS)

## AA:DTC P0113 INTAKE AIR TEMPERATURE SENSOR 1 CIRCUIT HIGH

### DTC DETECTING CONDITION:

- Immediately at fault recognition
- GENERAL DESCRIPTION <Ref. to GD(H6DO)-46, DTC P0113 INTAKE AIR TEMPERATURE SENSOR 1 CIRCUIT HIGH, Diagnostic Trouble Code (DTC) Detecting Criteria.>

### TROUBLE SYMPTOM:

- Improper idling
- Poor driving performance

### CAUTION:

After servicing or replacing faulty parts, perform Clear Memory Mode <Ref. to EN(H6DO)(diag)-62, OPERATION, Clear Memory Mode.>, and Inspection Mode <Ref. to EN(H6DO)(diag)-47, PROCEDURE, Inspection Mode.>.

### WIRING DIAGRAM:

Engine electrical system <Ref. to WI-32, Engine Electrical System.>

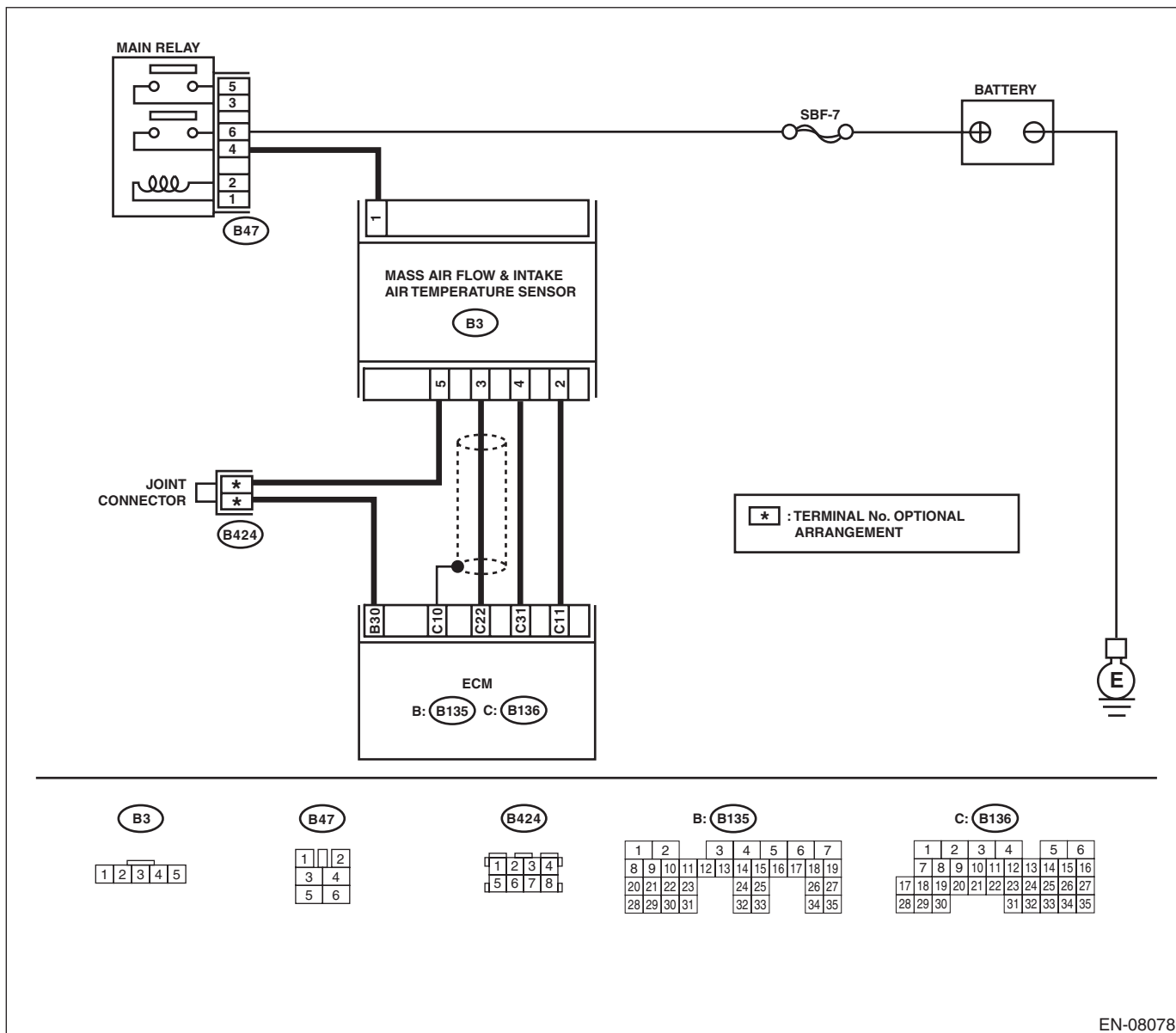

EN-08078

# Diagnostic Procedure with Diagnostic Trouble Code (DTC)

ENGINE (DIAGNOSTICS)

	Step	Check	Yes	No
1	<p><b>CHECK CURRENT DATA.</b></p> <p>1) Start the engine.</p> <p>2) Read the value of «Intake Air Temp.» using the Subaru Select Monitor or a general scan tool.</p> <p>NOTE:</p> <ul style="list-style-type: none"> <li>• Subaru Select Monitor</li> </ul> <p>For detailed operation procedures, refer to “READ CURRENT DATA FOR ENGINE”. &lt;Ref. to EN(H6DO)(diag)-37, Subaru Select Monitor.&gt;</p> <ul style="list-style-type: none"> <li>• General scan tool</li> </ul> <p>For detailed operation procedures, refer to the general scan tool operation manual.</p>	Is the value of «Intake Air Temp.» less than $-40^{\circ}\text{C}$ ( $-40^{\circ}\text{F}$ )?	Go to step 2.	<p>Even if DTC is detected, the circuit has returned to a normal condition at this time. Reproduce the failure, and then perform the diagnosis again.</p> <p>NOTE:</p> <p>In this case, temporary poor contact of connector, temporary open or short circuit of harness may be the cause.</p>
2	<p><b>CHECK FOR POOR CONTACT.</b></p> <p>Check for poor contact of ECM and mass air flow and intake air temperature sensor connector.</p>	Is there poor contact of ECM or mass air flow and intake air temperature sensor connector?	Repair the poor contact of ECM or mass air flow and intake air temperature sensor connector.	Go to step 3.
3	<p><b>CHECK HARNESS BETWEEN ECM AND MASS AIR FLOW AND INTAKE AIR TEMPERATURE SENSOR CONNECTOR.</b></p> <p>1) Turn the ignition switch to OFF.</p> <p>2) Disconnect the connector from ECM and the mass air flow and intake air temperature sensor.</p> <p>3) Measure the resistance of harness between ECM and the mass air flow and intake air temperature sensor connector.</p> <p><b>Connector &amp; terminal</b></p> <p><b>(B136) No. 31 — (B3) No. 4:</b></p> <p><b>(B135) No. 30 — (B3) No. 5:</b></p>	Is the resistance less than $1\ \Omega$ ?	Go to step 4.	<p>Repair the harness and connector.</p> <p>NOTE:</p> <p>In this case, repair the following item:</p> <ul style="list-style-type: none"> <li>• Open circuit in harness between ECM and mass air flow and intake air temperature sensor connector</li> <li>• Poor contact of joint connector</li> </ul>
4	<p><b>CHECK HARNESS BETWEEN ECM AND MASS AIR FLOW AND INTAKE AIR TEMPERATURE SENSOR CONNECTOR.</b></p> <p>1) Connect all connectors.</p> <p>2) Turn the ignition switch to ON.</p> <p>3) Disconnect the connectors from the mass air flow and intake air temperature sensor.</p> <p>4) Measure the voltage between ECM and chassis ground.</p> <p><b>Connector &amp; terminal</b></p> <p><b>(B136) No. 31 (+) — Chassis ground (-):</b></p>	Is the voltage 5 V or more?	Repair the short circuit of harness to power supply between ECM and mass air flow and intake air temperature sensor connector.	Replace the mass air flow and intake air temperature sensor. <Ref. to FU(H6DO)-40, Mass Air Flow and Intake Air Temperature Sensor.>

# Diagnostic Procedure with Diagnostic Trouble Code (DTC)

ENGINE (DIAGNOSTICS)

## AB:DTC P0116 ENGINE COOLANT TEMPERATURE SENSOR 1 CIRCUIT RANGE/PERFORMANCE

### DTC DETECTING CONDITION:

- Detected when two consecutive driving cycles with fault occur.
- GENERAL DESCRIPTION <Ref. to GD(H6DO)-48, DTC P0116 ENGINE COOLANT TEMPERATURE SENSOR 1 CIRCUIT RANGE/PERFORMANCE, Diagnostic Trouble Code (DTC) Detecting Criteria.>

### TROUBLE SYMPTOM:

- Hard to start
- Improper idling
- Poor driving performance

### CAUTION:

After servicing or replacing faulty parts, perform Clear Memory Mode <Ref. to EN(H6DO)(diag)-62, OPERATION, Clear Memory Mode.>, and Inspection Mode <Ref. to EN(H6DO)(diag)-47, PROCEDURE, Inspection Mode.>.

Step	Check	Yes	No
1 <b>CHECK FOR ANY OTHER DTC ON DISPLAY.</b>	Is any other DTC displayed?	Check the appropriate DTC using the "List of Diagnostic Trouble Code (DTC)". <Ref. to EN(H6DO)(diag)-89, List of Diagnostic Trouble Code (DTC).>	Go to step 2.
2 <b>CHECK ENGINE COOLANT TEMPERATURE SENSOR.</b> Measure the resistance between engine coolant temperature sensor terminals when the engine coolant is cold and after warmed up. <b>Terminals</b> <b>No. 1 — No. 2:</b>	Is the resistance of engine coolant temperature sensor different between when engine coolant is cold and after warmed up?	Repair the poor contact of ECM connector.	Replace the engine coolant temperature sensor. <Ref. to FU(H6DO)-30, Engine Coolant Temperature Sensor.>

## AC:DTC P0117 ENGINE COOLANT TEMPERATURE CIRCUIT LOW

### DTC DETECTING CONDITION:

- Immediately at fault recognition
- GENERAL DESCRIPTION <Ref. to GD(H6DO)-50, DTC P0117 ENGINE COOLANT TEMPERATURE CIRCUIT LOW, Diagnostic Trouble Code (DTC) Detecting Criteria.>

### TROUBLE SYMPTOM:

- Hard to start
- Improper idling
- Poor driving performance

### CAUTION:

**After servicing or replacing faulty parts, perform Clear Memory Mode <Ref. to EN(H6DO)(diag)-62, OPERATION, Clear Memory Mode.>, and Inspection Mode <Ref. to EN(H6DO)(diag)-47, PROCEDURE, Inspection Mode.>.**

### WIRING DIAGRAM:

Engine electrical system <Ref. to WI-32, Engine Electrical System.>

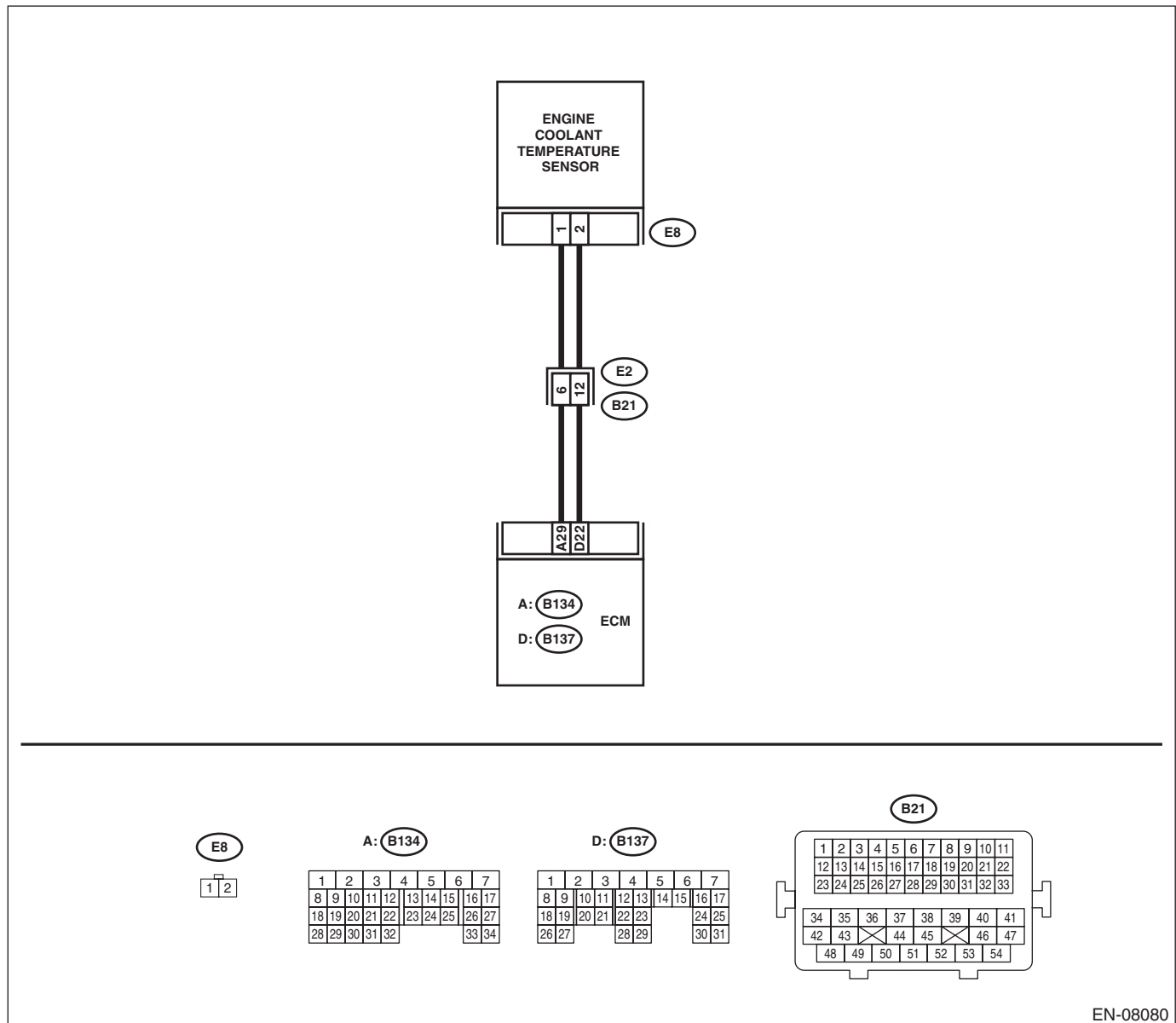

EN-08080

# Diagnostic Procedure with Diagnostic Trouble Code (DTC)

## ENGINE (DIAGNOSTICS)

	Step	Check	Yes	No
<p><b>1</b></p> <p><b>CHECK CURRENT DATA.</b></p> <p>1) Start the engine.</p> <p>2) Read the value of «Coolant Temp.» using the Subaru Select Monitor or a general scan tool.</p> <p>NOTE:</p> <ul style="list-style-type: none"> <li>• Subaru Select Monitor</li> </ul> <p>For detailed operation procedures, refer to “READ CURRENT DATA FOR ENGINE”. &lt;Ref. to EN(H6DO)(diag)-37, Subaru Select Monitor.&gt;</p> <ul style="list-style-type: none"> <li>• General scan tool</li> </ul> <p>For detailed operation procedures, refer to the general scan tool operation manual.</p>	<p>Is the value of «Coolant Temp.» 150°C (302°F) or more?</p>	<p>Go to step 2.</p>	<p>Even if DTC is detected, the circuit has returned to a normal condition at this time. Reproduce the failure, and then perform the diagnosis again.</p> <p>NOTE:</p> <p>In this case, temporary poor contact of connector, temporary open or short circuit of harness may be the cause.</p>	
<p><b>2</b></p> <p><b>CHECK HARNESS BETWEEN ECM AND ENGINE COOLANT TEMPERATURE SENSOR CONNECTOR.</b></p> <p>1) Turn the ignition switch to OFF.</p> <p>2) Disconnect the connectors from ECM and engine coolant temperature sensor.</p> <p>3) Measure the resistance between ECM and chassis ground.</p> <p><b>Connector &amp; terminal</b> <b>(B137) No. 22 — Chassis ground:</b></p>	<p>Is the resistance 1 MΩ or more?</p>	<p>Replace the engine coolant temperature sensor. &lt;Ref. to FU(H6DO)-30, Engine Coolant Temperature Sensor.&gt;</p>	<p>Repair short circuit in harness to ground between ECM and engine coolant temperature sensor connector.</p>	

## AD:DTC P0118 ENGINE COOLANT TEMPERATURE CIRCUIT HIGH

### DTC DETECTING CONDITION:

- Immediately at fault recognition
- GENERAL DESCRIPTION <Ref. to GD(H6DO)-52, DTC P0118 ENGINE COOLANT TEMPERATURE CIRCUIT HIGH, Diagnostic Trouble Code (DTC) Detecting Criteria.>

### TROUBLE SYMPTOM:

- Hard to start
- Improper idling
- Poor driving performance

### CAUTION:

**After servicing or replacing faulty parts, perform Clear Memory Mode <Ref. to EN(H6DO)(diag)-62, OPERATION, Clear Memory Mode.>, and Inspection Mode <Ref. to EN(H6DO)(diag)-47, PROCEDURE, Inspection Mode.>.**

### WIRING DIAGRAM:

Engine electrical system <Ref. to WI-32, Engine Electrical System.>

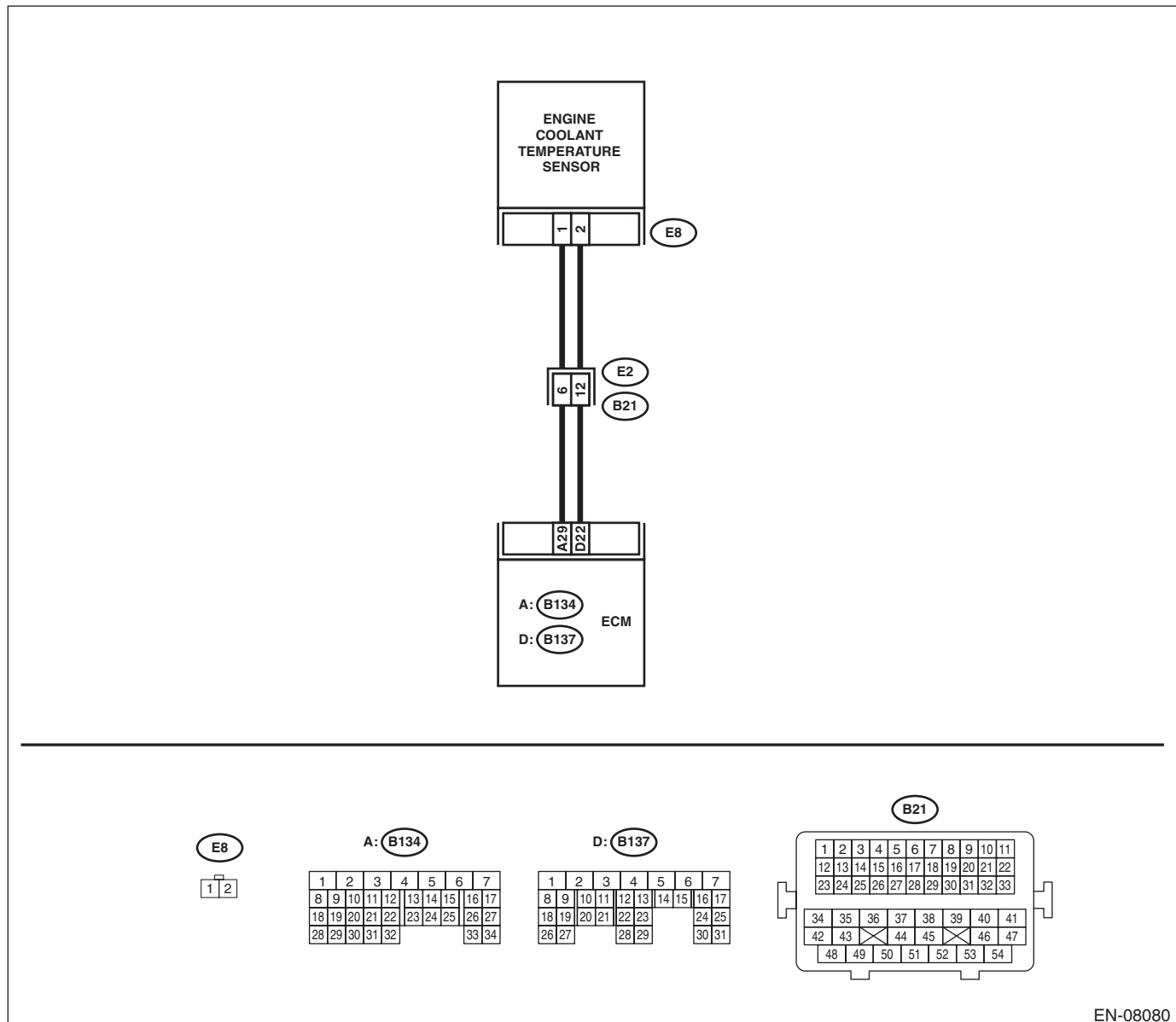

# Diagnostic Procedure with Diagnostic Trouble Code (DTC)

## ENGINE (DIAGNOSTICS)

Step	Check	Yes	No
<p><b>1 CHECK CURRENT DATA.</b></p> <p>1) Start the engine.</p> <p>2) Read the value of «Coolant Temp.» using the Subaru Select Monitor or a general scan tool.</p> <p>NOTE:</p> <ul style="list-style-type: none"> <li>Subaru Select Monitor</li> </ul> <p>For detailed operation procedures, refer to "READ CURRENT DATA FOR ENGINE". &lt;Ref. to EN(H6DO)(diag)-37, Subaru Select Monitor.&gt;</p> <ul style="list-style-type: none"> <li>General scan tool</li> </ul> <p>For detailed operation procedures, refer to the general scan tool operation manual.</p>	<p>Is the value of «Coolant Temp.» less than <math>-40^{\circ}\text{C}</math> (<math>-40^{\circ}\text{F}</math>)?</p>	<p>Go to step 2.</p>	<p>Even if DTC is detected, the circuit has returned to a normal condition at this time. Reproduce the failure, and then perform the diagnosis again.</p> <p>NOTE:</p> <p>In this case, temporary poor contact of connector, temporary open or short circuit of harness may be the cause.</p>
<p><b>2 CHECK FOR POOR CONTACT.</b></p> <p>Check for poor contact of ECM and engine coolant temperature sensor connector.</p>	<p>Is there poor contact of ECM or engine coolant temperature sensor connector?</p>	<p>Repair the poor contact of ECM or engine coolant temperature sensor connector.</p>	<p>Go to step 3.</p>
<p><b>3 CHECK HARNESS BETWEEN ECM AND ENGINE COOLANT TEMPERATURE SENSOR CONNECTOR.</b></p> <p>1) Turn the ignition switch to OFF.</p> <p>2) Disconnect the connectors from ECM and engine coolant temperature sensor.</p> <p>3) Measure the resistance of harness between ECM and engine coolant temperature sensor connector.</p> <p><b>Connector &amp; terminal</b></p> <p><b>(B134) No. 29 — (E8) No. 1:</b></p> <p><b>(B137) No. 22 — (E8) No. 2:</b></p>	<p>Is the resistance less than <math>1\ \Omega</math>?</p>	<p>Go to step 4.</p>	<p>Repair the harness and connector.</p> <p>NOTE:</p> <p>In this case, repair the following item:</p> <ul style="list-style-type: none"> <li>Open circuit in harness between ECM and engine coolant temperature sensor connector</li> <li>Poor contact of coupling connector</li> </ul>
<p><b>4 CHECK HARNESS BETWEEN ECM AND ENGINE COOLANT TEMPERATURE SENSOR CONNECTOR.</b></p> <p>1) Connect all connectors.</p> <p>2) Turn the ignition switch to ON.</p> <p>3) Measure the voltage between ECM and chassis ground.</p> <p><b>Connector &amp; terminal</b></p> <p><b>(B137) No. 22 (+) — Chassis ground (-):</b></p>	<p>Is the voltage 5 V or more?</p>	<p>Repair the short circuit to power in harness between ECM and engine coolant temperature sensor connector.</p>	<p>Replace the engine coolant temperature sensor. &lt;Ref. to FU(H6DO)-30, Engine Coolant Temperature Sensor.&gt;</p>



# Diagnostic Procedure with Diagnostic Trouble Code (DTC)

ENGINE (DIAGNOSTICS)

## AE:DTC P0122 THROTTLE/PEDAL POSITION SENSOR/SWITCH "A" CIRCUIT LOW

### DTC DETECTING CONDITION:

- Immediately at fault recognition
- GENERAL DESCRIPTION <Ref. to GD(H6DO)-54, DTC P0122 THROTTLE/PEDAL POSITION SENSOR/SWITCH "A" CIRCUIT LOW, Diagnostic Trouble Code (DTC) Detecting Criteria.>

### TROUBLE SYMPTOM:

- Improper idling
- Engine stalls.
- Poor driving performance

### CAUTION:

After servicing or replacing faulty parts, perform Clear Memory Mode <Ref. to EN(H6DO)(diag)-62, OPERATION, Clear Memory Mode.>, and Inspection Mode <Ref. to EN(H6DO)(diag)-47, PROCEDURE, Inspection Mode.>.

### WIRING DIAGRAM:

Engine electrical system <Ref. to WI-32, Engine Electrical System.>

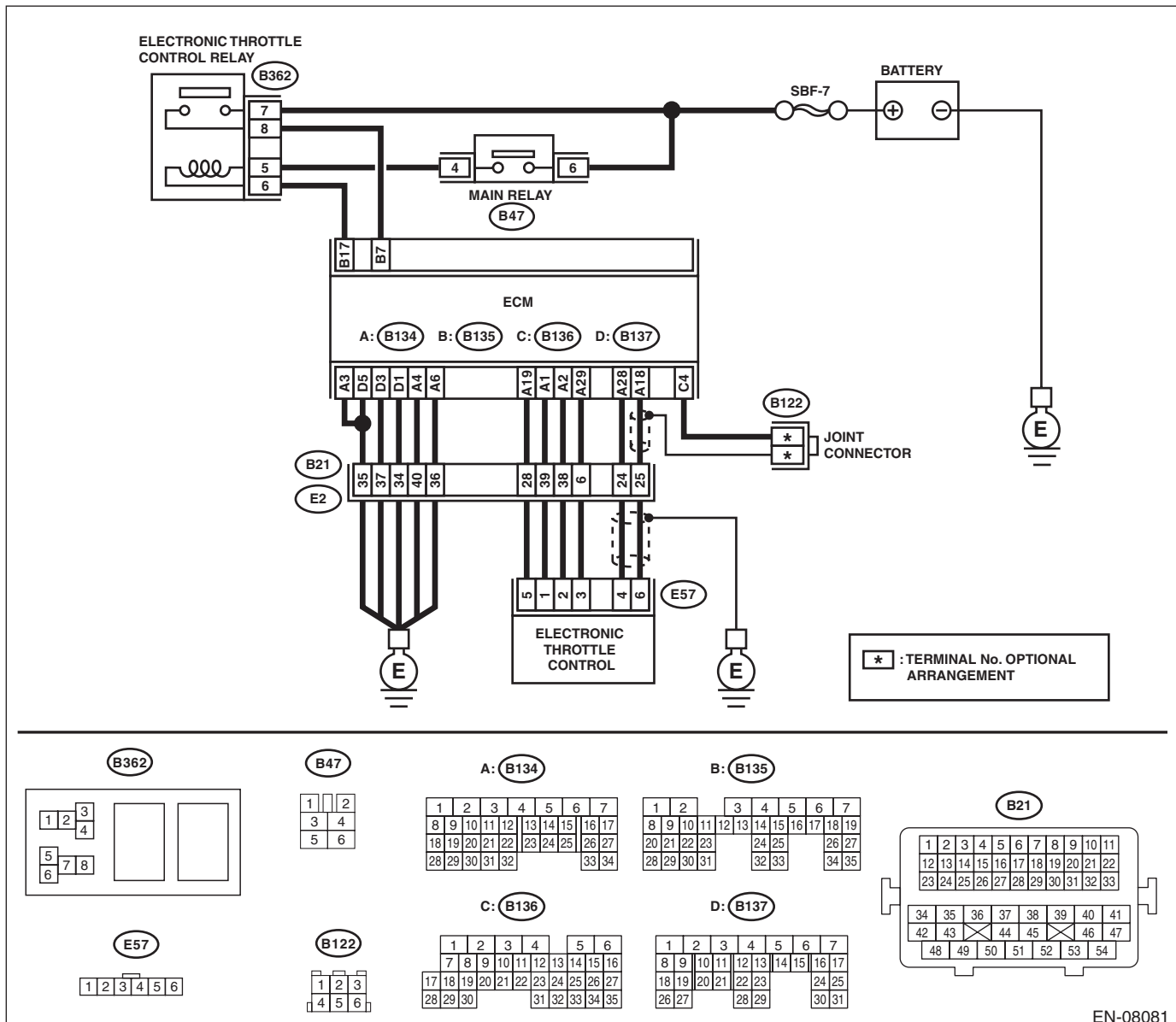

EN-08081

# Diagnostic Procedure with Diagnostic Trouble Code (DTC)

ENGINE (DIAGNOSTICS)

Step	Check	Yes	No
<p><b>1</b></p> <p><b>CHECK HARNESS BETWEEN ECM AND ELECTRONIC THROTTLE CONTROL.</b></p> <p>1) Turn the ignition switch to OFF.            2) Disconnect the connectors from ECM and electronic throttle control.            3) Measure the resistance between ECM and chassis ground.</p> <p><b>Connector &amp; terminal</b>  <b>(B134) No. 19 — Chassis ground:</b>  <b>(B134) No. 18 — Chassis ground:</b>  <b>(B134) No. 18 — (B136) No. 4:</b></p>	<p>Is the resistance 1 MΩ or more?</p>	<p>Go to step 2.</p>	<p>Repair the short circuit to ground in harness between ECM and electronic throttle control connector.</p>
<p><b>2</b></p> <p><b>CHECK SHORT CIRCUIT INSIDE THE ECM.</b></p> <p>1) Connect the connector to ECM.            2) Measure the resistance between electronic throttle control connector and engine ground.</p> <p><b>Connector &amp; terminal</b>  <b>(E57) No. 6 — Engine ground:</b></p>	<p>Is the resistance 1 MΩ or more?</p>	<p>Replace the electronic throttle control. &lt;Ref. to FU(H6DO)-19, Throttle Body.&gt;</p>	<p>Repair the short circuit to ground in harness between ECM and electronic throttle control connector. Replace the ECM if defective. &lt;Ref. to FU(H6DO)-51, Engine Control Module (ECM).&gt;</p>

# Diagnostic Procedure with Diagnostic Trouble Code (DTC)

ENGINE (DIAGNOSTICS)

## AF:DTC P0123 THROTTLE/PEDAL POSITION SENSOR/SWITCH "A" CIRCUIT HIGH

### DTC DETECTING CONDITION:

- Immediately at fault recognition
- GENERAL DESCRIPTION <Ref. to GD(H6DO)-56, DTC P0123 THROTTLE/PEDAL POSITION SENSOR/SWITCH "A" CIRCUIT HIGH, Diagnostic Trouble Code (DTC) Detecting Criteria.>

### TROUBLE SYMPTOM:

- Improper idling
- Engine stalls.
- Poor driving performance

### CAUTION:

After servicing or replacing faulty parts, perform Clear Memory Mode <Ref. to EN(H6DO)(diag)-62, OPERATION, Clear Memory Mode.>, and Inspection Mode <Ref. to EN(H6DO)(diag)-47, PROCEDURE, Inspection Mode.>.

### WIRING DIAGRAM:

Engine electrical system <Ref. to WI-32, Engine Electrical System.>

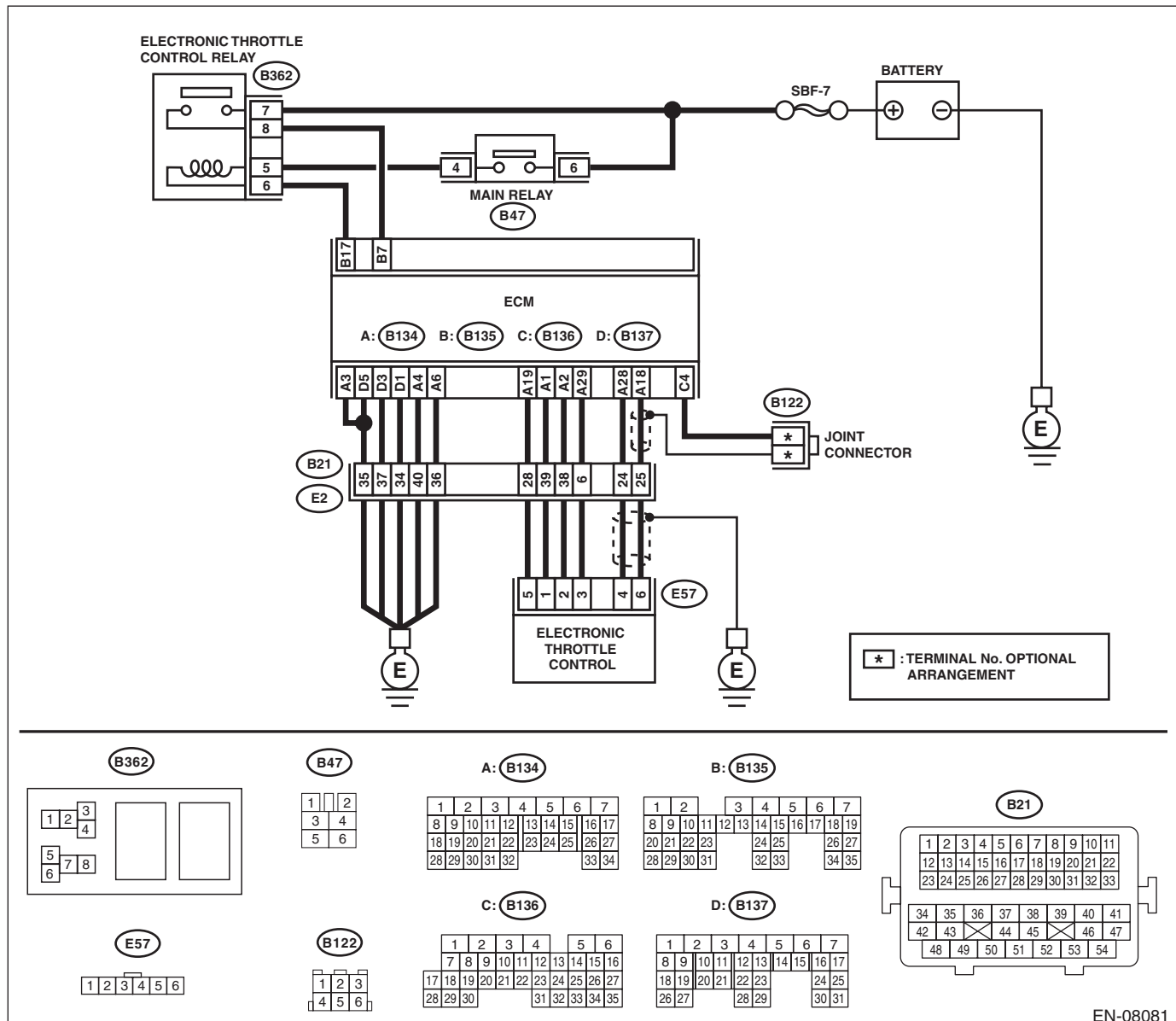

EN-08081

# Diagnostic Procedure with Diagnostic Trouble Code (DTC)

## ENGINE (DIAGNOSTICS)

Step	Check	Yes	No
<b>1 CHECK HARNESS BETWEEN ECM AND ELECTRONIC THROTTLE CONTROL.</b> 1) Turn the ignition switch to OFF. 2) Disconnect the connectors from ECM and electronic throttle control. 3) Measure the resistance of harness between ECM and electronic throttle control connector. <b>Connector &amp; terminal</b> <b>(B134) No. 18 — (E57) No. 6:</b> <b>(B134) No. 29 — (E57) No. 3:</b>	Is the resistance less than 1 $\Omega$ ?	Go to step 2.	Repair the harness and connector.  NOTE: In this case, repair the following item: <ul style="list-style-type: none"> <li>• Open circuit in harness between ECM and electronic throttle control connector</li> <li>• Poor contact of coupling connector</li> </ul>
<b>2 CHECK HARNESS BETWEEN ECM AND ELECTRONIC THROTTLE CONTROL.</b> 1) Connect the connector to ECM. 2) Measure the resistance between electronic throttle control connector and engine ground. <b>Connector &amp; terminal</b> <b>(E57) No. 3 — Engine ground:</b>	Is the resistance less than 5 $\Omega$ ?	Go to step 3.	Repair the harness and connector.  NOTE: In this case, repair the following item: <ul style="list-style-type: none"> <li>• Open circuit of harness between ECM and engine ground</li> <li>• Poor contact of ECM connector</li> <li>• Poor contact of coupling connector</li> </ul>
<b>3 CHECK HARNESS BETWEEN ECM AND ELECTRONIC THROTTLE CONTROL.</b> 1) Turn the ignition switch to ON. 2) Measure the voltage between electronic throttle control connector and engine ground. <b>Connector &amp; terminal</b> <b>(E57) No. 6 (+) — Engine ground (-):</b>	Is the voltage 5 V or more?	Repair the short circuit to power in harness between ECM and electronic throttle control connector.	Go to step 4.
<b>4 CHECK HARNESS BETWEEN ECM AND ELECTRONIC THROTTLE CONTROL.</b> 1) Turn the ignition switch to OFF. 2) Disconnect the connector from ECM. 3) Measure the resistance between ECM connectors. <b>Connector &amp; terminal</b> <b>(B134) No. 19 — (B134) No. 18:</b>	Is the resistance 1 M $\Omega$ or more?	Repair the poor contact of electronic throttle control connector. Replace the electronic throttle control if defective. <Ref. to FU(H6DO)-19, Throttle Body.>	Repair the short circuit to power in harness between ECM and electronic throttle control connector.

# Diagnostic Procedure with Diagnostic Trouble Code (DTC)

ENGINE (DIAGNOSTICS)

## AG:DTC P0125 INSUFFICIENT COOLANT TEMPERATURE FOR CLOSED LOOP FUEL CONTROL

### DTC DETECTING CONDITION:

- Detected when two consecutive driving cycles with fault occur.
- GENERAL DESCRIPTION <Ref. to GD(H6DO)-58, DTC P0125 INSUFFICIENT COOLANT TEMPERATURE FOR CLOSED LOOP FUEL CONTROL, Diagnostic Trouble Code (DTC) Detecting Criteria.>

### TROUBLE SYMPTOM:

Engine does not return to idle.

### CAUTION:

After servicing or replacing faulty parts, perform Clear Memory Mode <Ref. to EN(H6DO)(diag)-62, OPERATION, Clear Memory Mode.>, and Inspection Mode <Ref. to EN(H6DO)(diag)-47, PROCEDURE, Inspection Mode.>.

Step	Check	Yes	No
1 <b>CHECK TIRE SIZE.</b>	Is the tire size as specified and the same size as three other wheels?	Go to step 2.	Replace the tire.
2 <b>CHECK ENGINE COOLANT.</b> Check the following items: <ul style="list-style-type: none"><li>• Amount of engine coolant</li><li>• Engine coolant freeze</li><li>• Contamination of engine coolant</li></ul>	Is the engine coolant normal?	Go to step 3.	Fill or replace the engine coolant. <Ref. to CO(H6DO)-12, Engine Coolant.>
3 <b>CHECK THERMOSTAT.</b>	Does the thermostat remain opened?	Replace the thermostat. <Ref. to CO(H6DO)-15, Thermostat.>	Replace the engine coolant temperature sensor. <Ref. to FU(H6DO)-30, Engine Coolant Temperature Sensor.>

# Diagnostic Procedure with Diagnostic Trouble Code (DTC)

ENGINE (DIAGNOSTICS)

## AH:DTC P0128 COOLANT THERMOSTAT (ENGINE COOLANT TEMPERATURE BELOW THERMOSTAT REGULATING TEMPERATURE)

### DTC DETECTING CONDITION:

- Detected when two consecutive driving cycles with fault occur.
- GENERAL DESCRIPTION <Ref. to GD(H6DO)-60, DTC P0128 COOLANT THERMOSTAT (ENGINE COOLANT TEMPERATURE BELOW THERMOSTAT REGULATING TEMPERATURE), Diagnostic Trouble Code (DTC) Detecting Criteria.>

### TROUBLE SYMPTOM:

Thermostat remains open.

### CAUTION:

After servicing or replacing faulty parts, perform Clear Memory Mode <Ref. to EN(H6DO)(diag)-62, OPERATION, Clear Memory Mode.>, and Inspection Mode <Ref. to EN(H6DO)(diag)-47, PROCEDURE, Inspection Mode.>.

Step	Check	Yes	No
1 <b>CHECK FOR ANY OTHER DTC ON DISPLAY.</b>	Is any other DTC displayed?	Check the appropriate DTC using the "List of Diagnostic Trouble Code (DTC)". <Ref. to EN(H6DO)(diag)-89, List of Diagnostic Trouble Code (DTC).>	Go to step 2.
2 <b>CHECK ENGINE COOLANT.</b>	Is the engine coolant amount normal?	Go to step 3.	Refill the engine coolant. <Ref. to CO(H6DO)-12, Engine Coolant.>
3 <b>CHECK RADIATOR FAN.</b> 1) Start the engine. 2) Check the radiator fan operation.	Does the radiator fan continuously rotate for 3 minutes or more during idling?	Repair radiator fan circuit. <Ref. to CO(H6DO)-23, Radiator Main Fan and Fan Motor.> and <Ref. to CO(H6DO)-27, Radiator Sub Fan and Fan Motor.>	Replace the thermostat. <Ref. to CO(H6DO)-15, Thermostat.>

# Diagnostic Procedure with Diagnostic Trouble Code (DTC)

ENGINE (DIAGNOSTICS)

## AI: DTC P0131 O2 SENSOR CIRCUIT LOW VOLTAGE (BANK 1 SENSOR 1)

### DTC DETECTING CONDITION:

- Immediately at fault recognition
- GENERAL DESCRIPTION <Ref. to GD(H6DO)-64, DTC P0131 O2 SENSOR CIRCUIT LOW VOLTAGE (BANK 1 SENSOR 1), Diagnostic Trouble Code (DTC) Detecting Criteria.>

### CAUTION:

After servicing or replacing faulty parts, perform Clear Memory Mode <Ref. to EN(H6DO)(diag)-62, OPERATION, Clear Memory Mode.>, and Inspection Mode <Ref. to EN(H6DO)(diag)-47, PROCEDURE, Inspection Mode.>.

### WIRING DIAGRAM:

Engine electrical system <Ref. to WI-32, Engine Electrical System.>

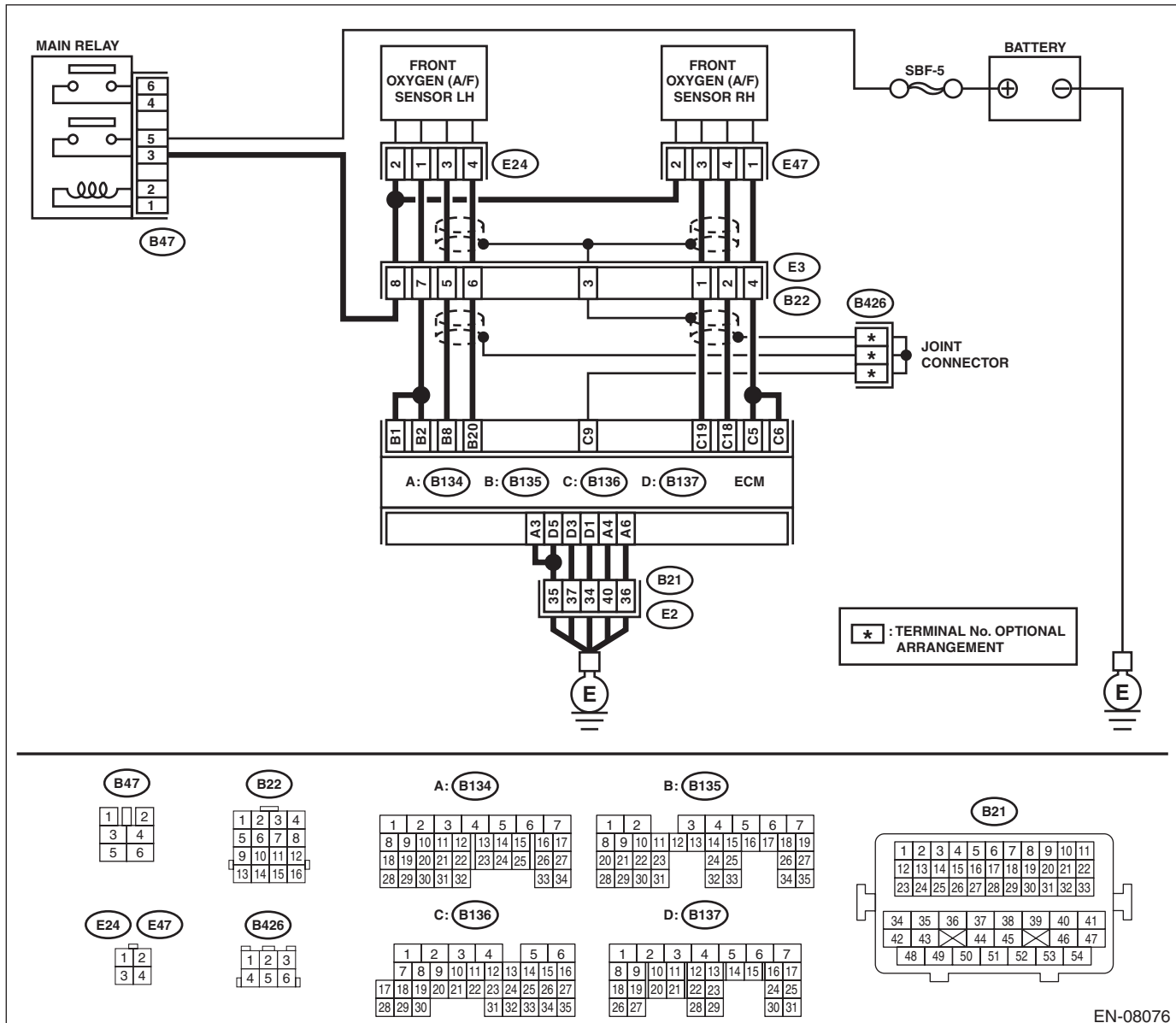

EN-08076

# Diagnostic Procedure with Diagnostic Trouble Code (DTC)

ENGINE (DIAGNOSTICS)

Step	Check	Yes	No
<b>1 CHECK FRONT OXYGEN (A/F) SENSOR CONNECTOR AND COUPLING CONNECTOR.</b>	Has water entered the connector?	Completely remove any water inside.	Go to step 2.
<b>2 CHECK HARNESS BETWEEN ECM AND FRONT OXYGEN (A/F) SENSOR CONNECTOR.</b> 1) Turn the ignition switch to OFF. 2) Disconnect the connectors from ECM and front oxygen (A/F) sensor connector. 3) Measure the resistance between ECM and chassis ground. <b>Connector &amp; terminal</b> <b>(B136) No. 18 — Chassis ground:</b> <b>(B136) No. 19 — Chassis ground:</b>	Is the resistance 1 MΩ or more?	Go to step 3.	Repair the ground short circuit of harness between ECM and front oxygen (A/F) sensor connector.
<b>3 CHECK FOR POOR CONTACT.</b> Check for poor contact of the front oxygen (A/F) sensor connector.	Is there poor contact of front oxygen (A/F) sensor connector?	Repair the poor contact of front oxygen (A/F) sensor connector.	Replace the front oxygen (A/F) sensor. <Ref. to FU(H6DO)-48, Front Oxygen (A/F) Sensor.>



# Diagnostic Procedure with Diagnostic Trouble Code (DTC)

ENGINE (DIAGNOSTICS)

## AJ:DTC P0132 O2 SENSOR CIRCUIT HIGH VOLTAGE (BANK 1 SENSOR 1)

### DTC DETECTING CONDITION:

- Immediately at fault recognition
- GENERAL DESCRIPTION <Ref. to GD(H6DO)-66, DTC P0132 O2 SENSOR CIRCUIT HIGH VOLTAGE (BANK 1 SENSOR 1), Diagnostic Trouble Code (DTC) Detecting Criteria.>

### CAUTION:

After servicing or replacing faulty parts, perform Clear Memory Mode <Ref. to EN(H6DO)(diag)-62, OPERATION, Clear Memory Mode.>, and Inspection Mode <Ref. to EN(H6DO)(diag)-47, PROCEDURE, Inspection Mode.>.

### WIRING DIAGRAM:

Engine electrical system <Ref. to WI-32, Engine Electrical System.>

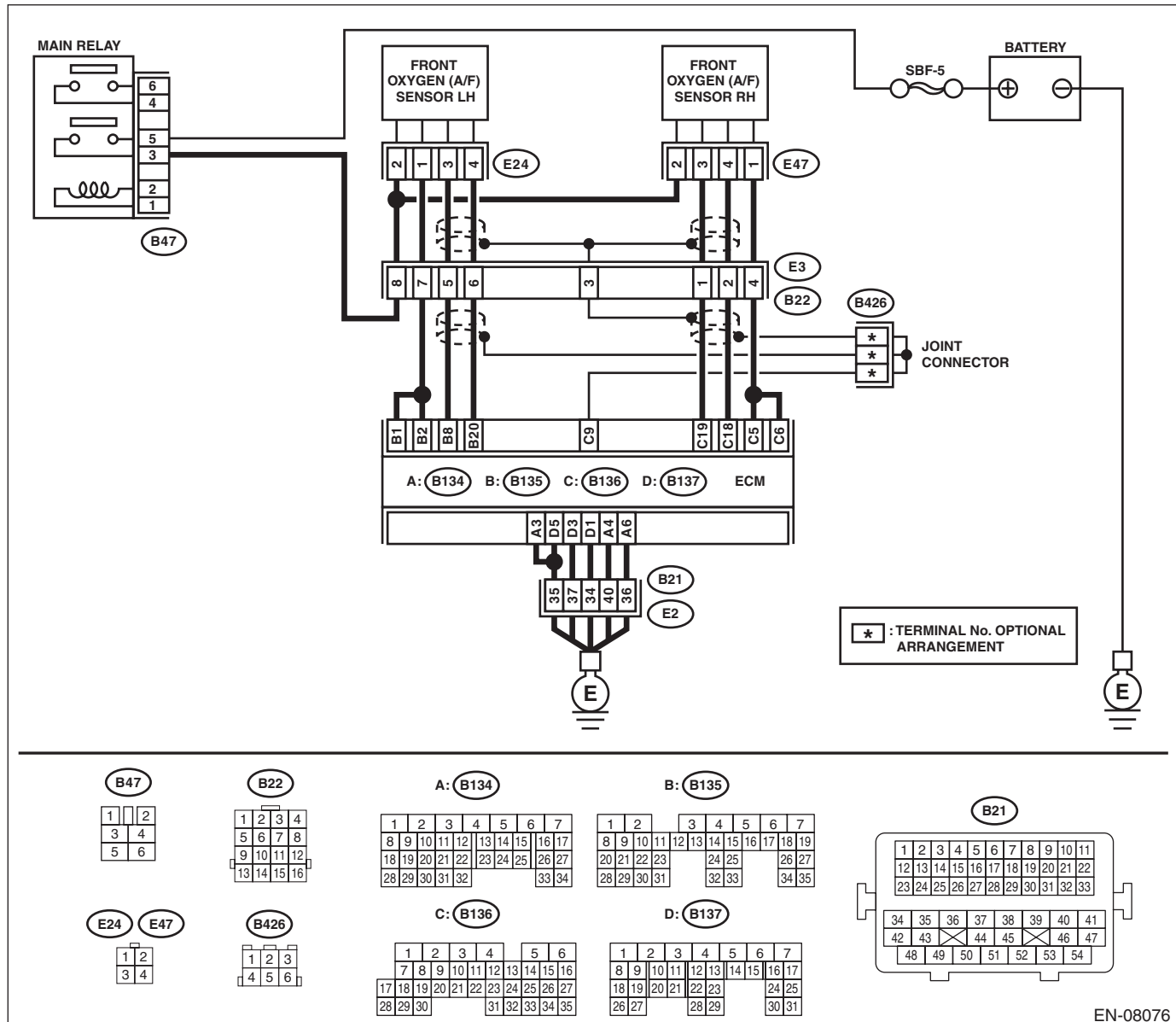

EN-08076

## Diagnostic Procedure with Diagnostic Trouble Code (DTC)

ENGINE (DIAGNOSTICS)

Step	Check	Yes	No
<b>1</b> <b>CHECK FRONT OXYGEN (A/F) SENSOR CONNECTOR AND COUPLING CONNECTOR.</b>	Has water entered the connector?	Completely remove any water inside.	Go to step 2.
<b>2</b> <b>CHECK HARNESS BETWEEN ECM AND FRONT OXYGEN (A/F) SENSOR CONNECTOR.</b> 1) Turn the ignition switch to OFF. 2) Disconnect the connectors from front oxygen (A/F) sensor. 3) Turn the ignition switch to ON. 4) Measure the voltage between ECM and chassis ground. <b>Connector &amp; terminal</b> <b>(B136) No. 18 (+) — Chassis ground (-):</b> <b>(B136) No. 19 (+) — Chassis ground (-):</b>	Is the voltage 8 V or more?	Repair the short circuit to power in the harness between ECM and front oxygen (A/F) sensor connector.	Replace the front oxygen (A/F) sensor. <Ref. to FU(H6DO)-48, Front Oxygen (A/F) Sensor.>

# Diagnostic Procedure with Diagnostic Trouble Code (DTC)

ENGINE (DIAGNOSTICS)

## AK:DTC P0134 O2 SENSOR CIRCUIT NO ACTIVITY DETECTED (BANK 1 SENSOR 1)

### DTC DETECTING CONDITION:

- Immediately at fault recognition
- GENERAL DESCRIPTION <Ref. to GD(H6DO)-68, DTC P0134 O2 SENSOR CIRCUIT NO ACTIVITY DETECTED (BANK 1 SENSOR 1), Diagnostic Trouble Code (DTC) Detecting Criteria.>

### CAUTION:

After servicing or replacing faulty parts, perform Clear Memory Mode <Ref. to EN(H6DO)(diag)-62, OPERATION, Clear Memory Mode.>, and Inspection Mode <Ref. to EN(H6DO)(diag)-47, PROCEDURE, Inspection Mode.>.

### WIRING DIAGRAM:

Engine electrical system <Ref. to WI-32, Engine Electrical System.>

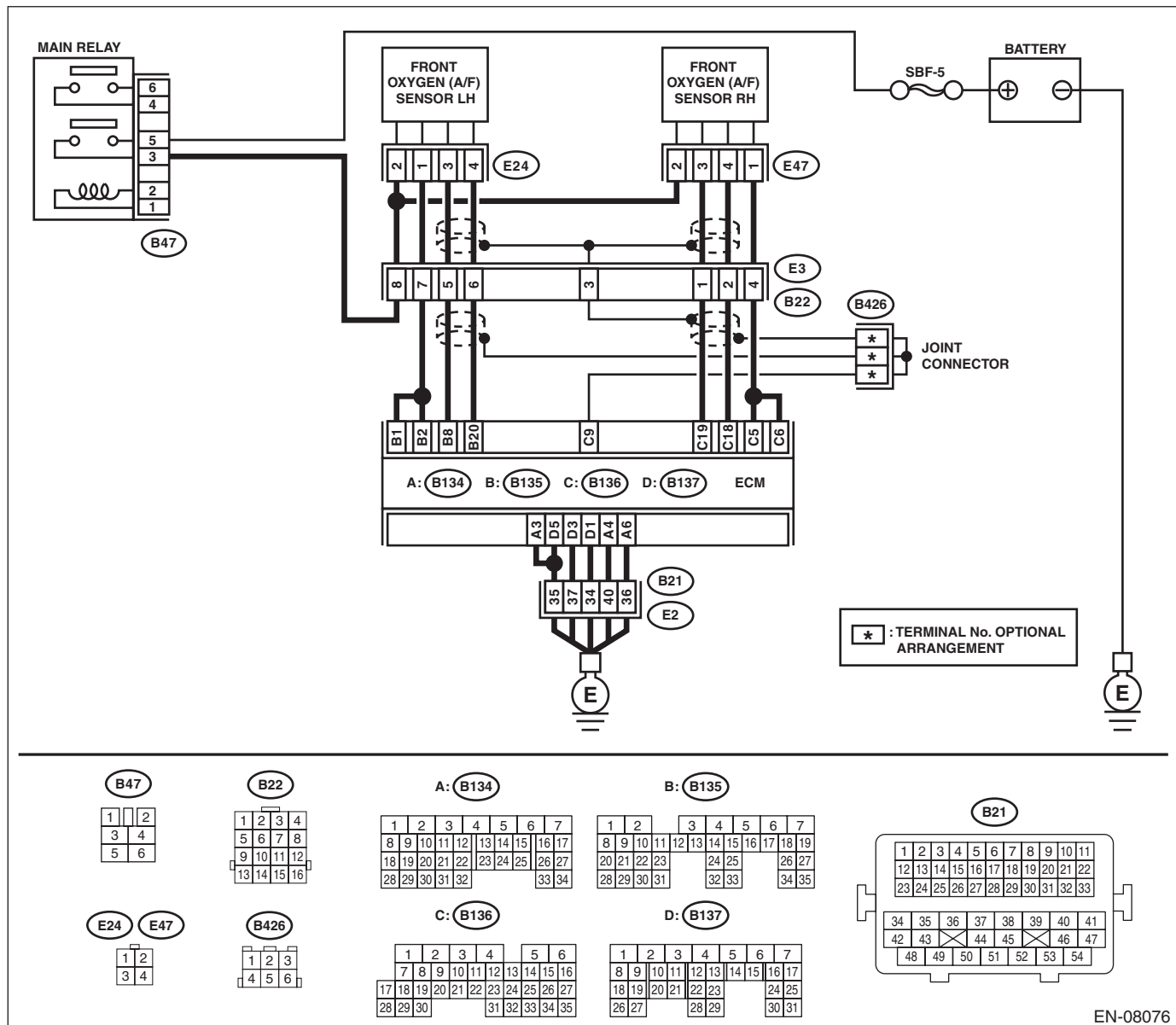

EN-08076

# Diagnostic Procedure with Diagnostic Trouble Code (DTC)

ENGINE (DIAGNOSTICS)

Step	Check	Yes	No
<b>1 CHECK HARNESS BETWEEN ECM AND FRONT OXYGEN (A/F) SENSOR CONNECTOR.</b> 1) Turn the ignition switch to OFF. 2) Disconnect the connectors from ECM and front oxygen (A/F) sensor connector. 3) Measure the resistance of harness between ECM and front oxygen (A/F) sensor connector. <b>Connector &amp; terminal</b> <b>(B136) No. 19 — (E47) No. 3:</b> <b>(B136) No. 18 — (E47) No. 4:</b>	Is the resistance less than 1 Ω?	Go to step 2.	Repair the harness and connector.  NOTE: In this case, repair the following item: • Open circuit in harness between ECM and front oxygen (A/F) sensor connector • Poor contact of coupling connector
<b>2 CHECK FOR POOR CONTACT.</b> Check for poor contact of ECM and front oxygen (A/F) sensor connector.	Is there poor contact of ECM or front oxygen (A/F) sensor connector?	Repair the poor contact of ECM or front oxygen (A/F) sensor connector.	Replace the front oxygen (A/F) sensor. <Ref. to FU(H6DO)-48, Front Oxygen (A/F) Sensor.>

# Diagnostic Procedure with Diagnostic Trouble Code (DTC)

ENGINE (DIAGNOSTICS)

## AL:DTC P0137 O2 SENSOR CIRCUIT LOW VOLTAGE (BANK 1 SENSOR 2)

### DTC DETECTING CONDITION:

- Detected when two consecutive driving cycles with fault occur.
- GENERAL DESCRIPTION <Ref. to GD(H6DO)-70, DTC P0137 O2 SENSOR CIRCUIT LOW VOLTAGE (BANK 1 SENSOR 2), Diagnostic Trouble Code (DTC) Detecting Criteria.>

### CAUTION:

After servicing or replacing faulty parts, perform Clear Memory Mode <Ref. to EN(H6DO)(diag)-62, OPERATION, Clear Memory Mode.>, and Inspection Mode <Ref. to EN(H6DO)(diag)-47, PROCEDURE, Inspection Mode.>.

### WIRING DIAGRAM:

Engine electrical system <Ref. to WI-32, Engine Electrical System.>

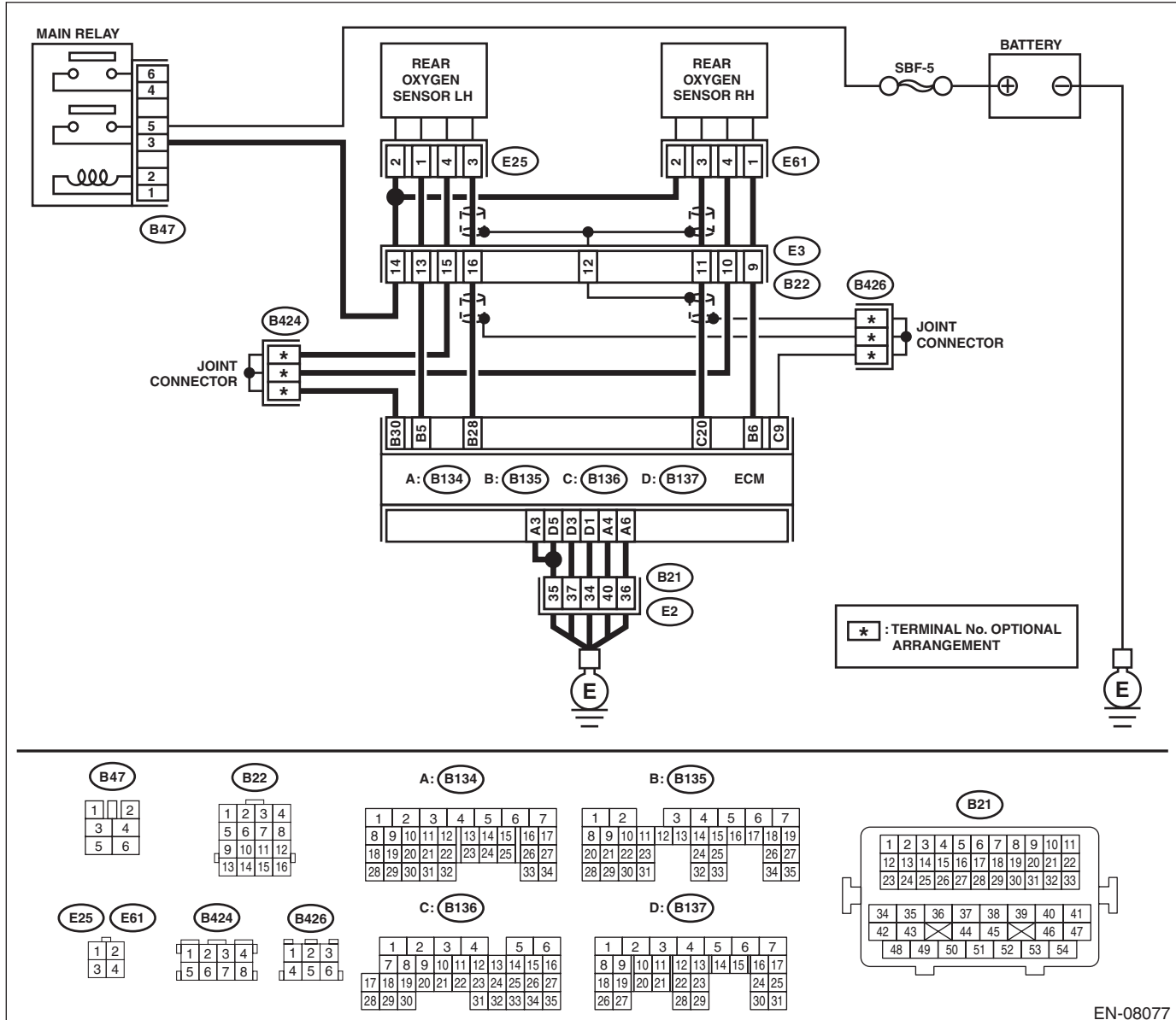

EN-08077

# Diagnostic Procedure with Diagnostic Trouble Code (DTC)

## ENGINE (DIAGNOSTICS)

Step	Check	Yes	No
<p><b>1 CHECK REAR OXYGEN SENSOR DATA.</b>                      1) Warm up the engine until engine coolant temperature is higher than 75°C (167°F), and keep the engine speed at 3,000 rpm. (2 minutes maximum)                      2) Read the value of «Front O2 Sensor #1» using the Subaru Select Monitor or a general scan tool.                      NOTE:                      • Subaru Select Monitor                      For detailed operation procedures, refer to “READ CURRENT DATA FOR ENGINE”. &lt;Ref. to EN(H6DO)(diag)-37, Subaru Select Monitor.&gt;                      • General scan tool                      For detailed operation procedures, refer to the general scan tool operation manual.</p>	Is the value of «Front O2 Sensor #1» 0.490 V or more?	Go to step 5.	Go to step 2.
<p><b>2 CHECK REAR OXYGEN SENSOR CONNECTOR AND COUPLING CONNECTOR.</b></p>	Has water entered the connector?	Completely remove any water inside.	Go to step 3.
<p><b>3 CHECK HARNESS BETWEEN ECM AND REAR OXYGEN SENSOR CONNECTOR.</b>                      1) Turn the ignition switch to OFF.                      2) Disconnect the connector from ECM and rear oxygen sensor.                      3) Measure the resistance of harness between ECM and rear oxygen sensor connector.  <i>Connector &amp; terminal</i>  <i>(B136) No. 20 — (E61) No. 3:</i>  <i>(B135) No. 30 — (E61) No. 4:</i></p>	Is the resistance less than 1 Ω?	Go to step 4.	Repair the harness and connector. NOTE: In this case, repair the following item: • Open circuit in harness between ECM and rear oxygen sensor connector • Poor contact of coupling connector
<p><b>4 CHECK HARNESS BETWEEN ECM AND REAR OXYGEN SENSOR CONNECTOR.</b>                      1) Connect the connector to ECM.                      2) Turn the ignition switch to ON.                      3) Measure the voltage between rear oxygen sensor connector and chassis ground.  <i>Connector &amp; terminal</i>  <i>(E61) No. 3 (+) — Chassis ground (-):</i></p>	Is the voltage 0.2 — 0.5 V?	Replace the rear oxygen sensor. <Ref. to FU(H6DO)-50, Rear Oxygen Sensor.>	Repair the harness and connector. NOTE: In this case, repair the following item: • Open circuit in harness between ECM and rear oxygen sensor connector • Poor contact of ECM connector • Poor contact of coupling connector
<p><b>5 CHECK EXHAUST SYSTEM.</b>                      Check exhaust system parts.                      NOTE:                      Check the following items.                      • Looseness and improper fitting of exhaust system parts                      • Damage (crack, hole etc.) of parts                      • Loose part and improper installation between front oxygen (A/F) sensor and rear oxygen sensor</p>	Is there any fault in exhaust system?	Repair or replace faulty parts.	Replace the rear oxygen sensor. <Ref. to FU(H6DO)-50, Rear Oxygen Sensor.>

# Diagnostic Procedure with Diagnostic Trouble Code (DTC)

ENGINE (DIAGNOSTICS)

## AM:DTC P0138 O2 SENSOR CIRCUIT HIGH VOLTAGE (BANK 1 SENSOR 2)

### DTC DETECTING CONDITION:

- Detected when two consecutive driving cycles with fault occur.
- GENERAL DESCRIPTION <Ref. to GD(H6DO)-72, DTC P0138 O2 SENSOR CIRCUIT HIGH VOLTAGE (BANK 1 SENSOR 2), Diagnostic Trouble Code (DTC) Detecting Criteria.>

### CAUTION:

After servicing or replacing faulty parts, perform Clear Memory Mode <Ref. to EN(H6DO)(diag)-62, OPERATION, Clear Memory Mode.>, and Inspection Mode <Ref. to EN(H6DO)(diag)-47, PROCEDURE, Inspection Mode.>.

### WIRING DIAGRAM:

Engine electrical system <Ref. to WI-32, Engine Electrical System.>

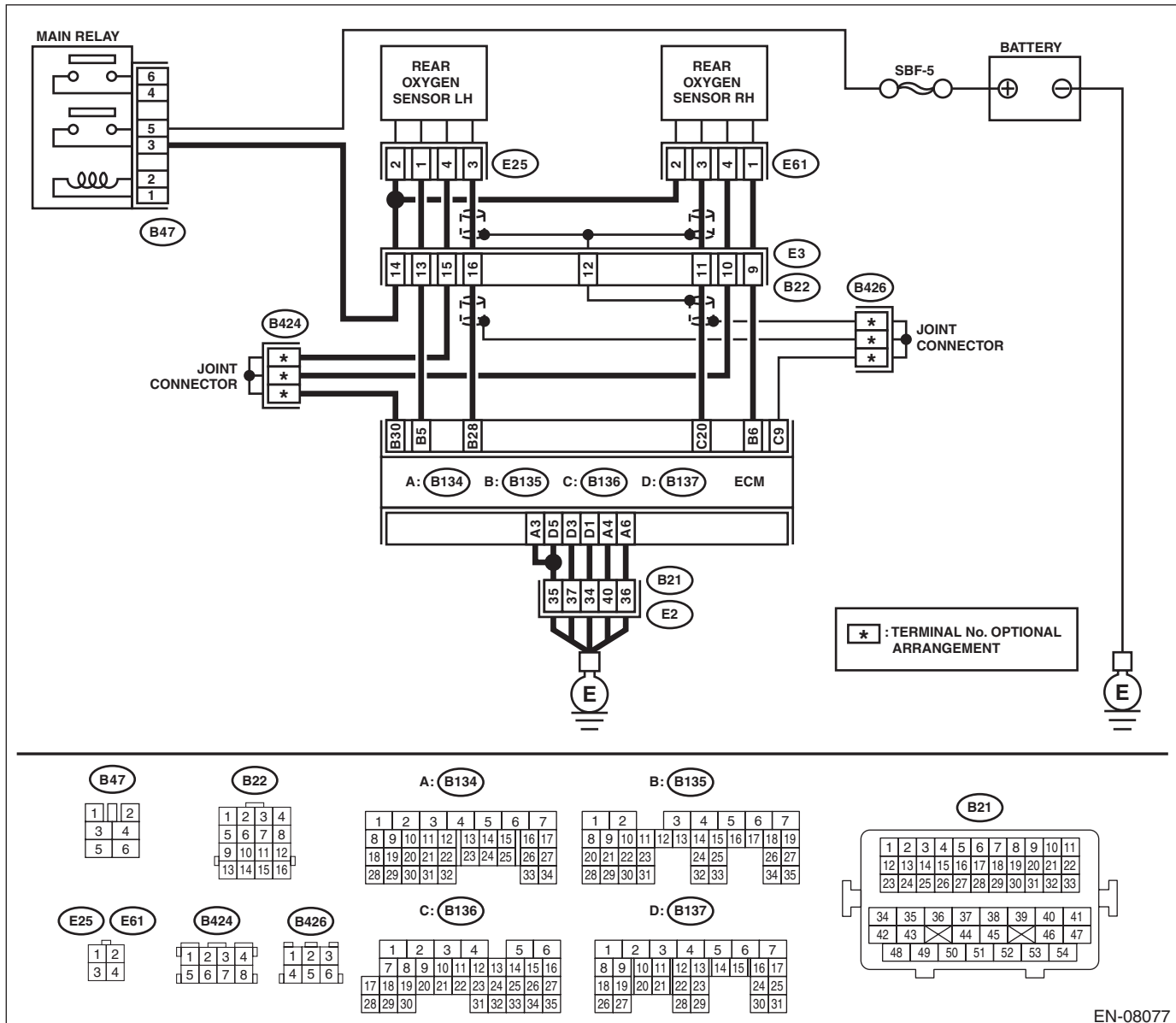

EN-08077

# Diagnostic Procedure with Diagnostic Trouble Code (DTC)

## ENGINE (DIAGNOSTICS)

	Step	Check	Yes	No
1	<p><b>CHECK REAR OXYGEN SENSOR DATA.</b></p> <p>1) Warm up the engine until engine coolant temperature is higher than 75°C (167°F), and rapidly reduce the engine speed from 3,000 rpm.</p> <p>2) Read the value of «Front O2 Sensor #1» using the Subaru Select Monitor or a general scan tool.</p> <p>NOTE:</p> <ul style="list-style-type: none"> <li>Subaru Select Monitor</li> </ul> <p>For detailed operation procedures, refer to “READ CURRENT DATA FOR ENGINE”. &lt;Ref. to EN(H6DO)(diag)-37, Subaru Select Monitor.&gt;</p> <ul style="list-style-type: none"> <li>General scan tool</li> </ul> <p>For detailed operation procedures, refer to the general scan tool operation manual.</p>	Is the value of «Front O2 Sensor #1» 0.250 V or less?	Go to step 5.	Go to step 2.
2	<p><b>CHECK REAR OXYGEN SENSOR CONNECTOR AND COUPLING CONNECTOR.</b></p>	Has water entered the connector?	Completely remove any water inside.	Go to step 3.
3	<p><b>CHECK HARNESS BETWEEN ECM AND REAR OXYGEN SENSOR CONNECTOR.</b></p> <p>1) Turn the ignition switch to OFF.</p> <p>2) Disconnect the connector from ECM and rear oxygen sensor.</p> <p>3) Measure the resistance of harness between ECM and rear oxygen sensor connector.</p> <p><b>Connector &amp; terminal</b>  <b>(B136) No. 20 — (E61) No. 3:</b>  <b>(B135) No. 30 — (E61) No. 4:</b></p>	Is the resistance less than 1 Ω?	Go to step 4.	<p>Repair the harness and connector.</p> <p>NOTE:</p> <p>In this case, repair the following item:</p> <ul style="list-style-type: none"> <li>Open circuit in harness between ECM and rear oxygen sensor connector</li> <li>Poor contact of coupling connector</li> </ul>
4	<p><b>CHECK HARNESS BETWEEN ECM AND REAR OXYGEN SENSOR CONNECTOR.</b></p> <p>1) Connect the connector to ECM.</p> <p>2) Turn the ignition switch to ON.</p> <p>3) Measure the voltage between rear oxygen sensor connector and chassis ground.</p> <p><b>Connector &amp; terminal</b>  <b>(E61) No. 3 (+) — Chassis ground (-):</b></p>	Is the voltage 0.2 — 0.5 V?	Replace the rear oxygen sensor. <Ref. to FU(H6DO)-50, Rear Oxygen Sensor.>	<p>Repair the harness and connector.</p> <p>NOTE:</p> <p>In this case, repair the following item:</p> <ul style="list-style-type: none"> <li>Open circuit in harness between ECM and rear oxygen sensor connector</li> <li>Poor contact of ECM connector</li> <li>Poor contact of coupling connector</li> </ul>
5	<p><b>CHECK EXHAUST SYSTEM.</b></p> <p>Check exhaust system parts.</p> <p>NOTE:</p> <p>Check the following items.</p> <ul style="list-style-type: none"> <li>Looseness and improper fitting of exhaust system parts</li> <li>Damage (crack, hole etc.) of parts</li> <li>Loose part and improper installation between front oxygen (A/F) sensor and rear oxygen sensor</li> </ul>	Is there any fault in exhaust system?	Repair or replace faulty parts.	<p>Replace the rear oxygen sensor.</p> <p>&lt;Ref. to FU(H6DO)-50, Rear Oxygen Sensor.&gt;</p>



# Diagnostic Procedure with Diagnostic Trouble Code (DTC)

ENGINE (DIAGNOSTICS)

## AN:DTC P013A O2 SENSOR SLOW RESPONSE - RICH TO LEAN (BANK 1 SENSOR 2)

### DTC DETECTING CONDITION:

- Detected when two consecutive driving cycles with fault occur.
- GENERAL DESCRIPTION <Ref. to GD(H6DO)-73, DTC P013A O2 SENSOR SLOW RESPONSE - RICH TO LEAN (BANK 1 SENSOR 2), Diagnostic Trouble Code (DTC) Detecting Criteria.>

### CAUTION:

After servicing or replacing faulty parts, perform Clear Memory Mode <Ref. to EN(H6DO)(diag)-62, OPERATION, Clear Memory Mode.>, and Inspection Mode <Ref. to EN(H6DO)(diag)-47, PROCEDURE, Inspection Mode.>.

### WIRING DIAGRAM:

Engine electrical system <Ref. to WI-32, Engine Electrical System.>

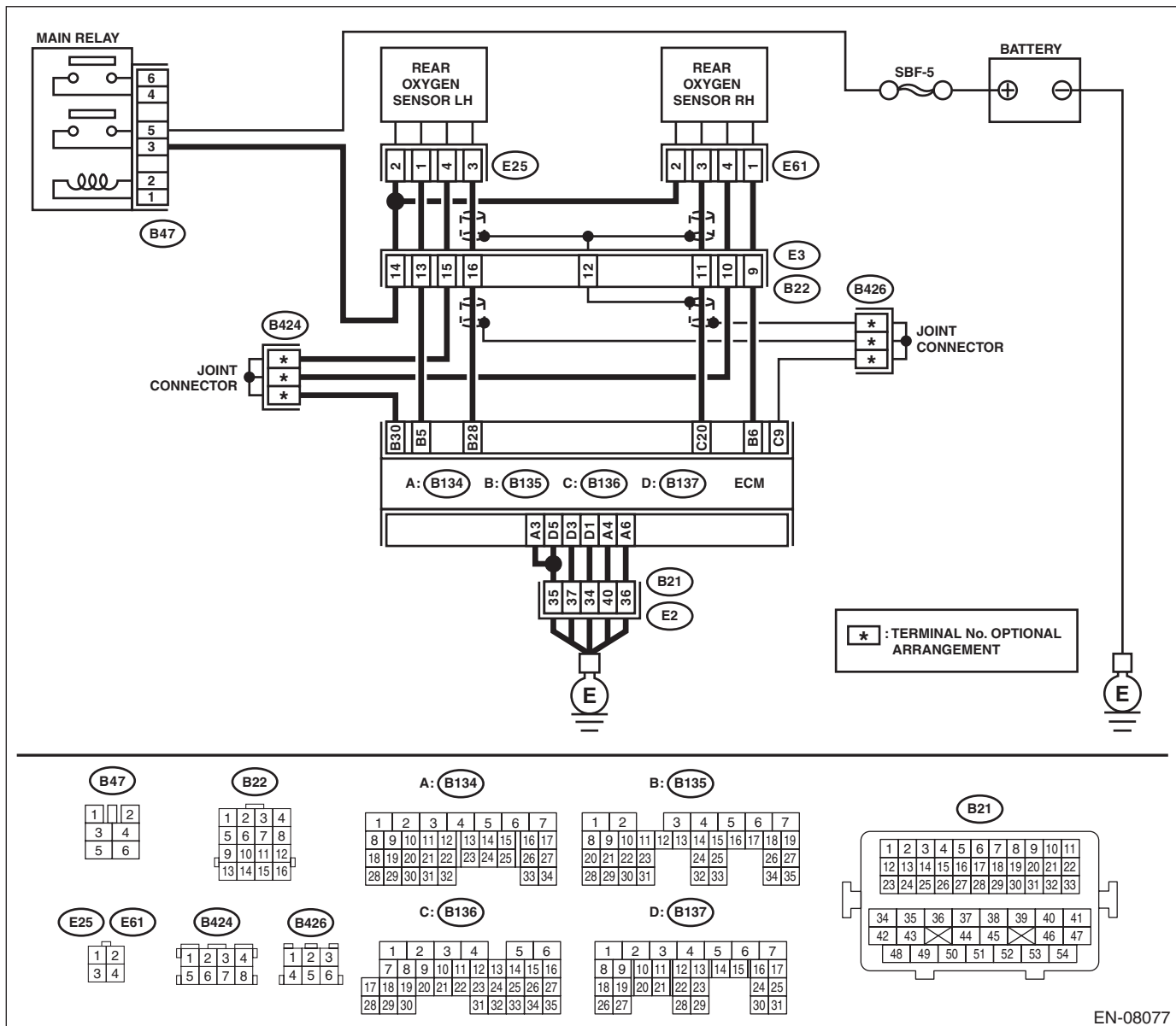

EN-08077

# Diagnostic Procedure with Diagnostic Trouble Code (DTC)

ENGINE (DIAGNOSTICS)

Step	Check	Yes	No
<p><b>1</b>     <b>CHECK HARNESS BETWEEN ECM AND REAR OXYGEN SENSOR CONNECTOR.</b>            1) Turn the ignition switch to OFF.            2) Disconnect the connector from ECM and rear oxygen sensor.            3) Measure the resistance of harness between ECM and rear oxygen sensor connector.  <b>Connector &amp; terminal</b>  <b>(B136) No. 20 — (E61) No. 3:</b></p>	<p>Is the resistance less than 1 Ω?</p>	<p>Go to step 2.</p>	<p>Repair the harness and connector.  <b>NOTE:</b>            In this case, repair the following item:            • Open circuit in harness between ECM and rear oxygen sensor connector            • Poor contact of coupling connector</p>
<p><b>2</b>     <b>CHECK HARNESS BETWEEN ECM AND REAR OXYGEN SENSOR CONNECTOR.</b>            Measure the resistance between rear oxygen sensor connector and chassis ground.  <b>Connector &amp; terminal</b>  <b>(E61) No. 3 — Chassis ground:</b></p>	<p>Is the resistance 1 MΩ or more?</p>	<p>Go to step 3.</p>	<p>Repair the ground short circuit of harness between ECM and rear oxygen sensor connector.</p>
<p><b>3</b>     <b>CHECK REAR OXYGEN SENSOR.</b>            Measure the resistance between rear oxygen sensor terminals.  <b>Terminals</b>  <b>No. 3 — No. 4</b></p>	<p>Is the resistance less than 1 Ω?</p>	<p>Replace the rear oxygen sensor.            &lt;Ref. to FU(H6DO)-50, Rear Oxygen Sensor.&gt;</p>	<p>Even if DTC is detected, the circuit has returned to a normal condition at this time. Reproduce the failure, and then perform the diagnosis again.  <b>NOTE:</b>            In this case, temporary poor contact of connector, temporary open or short circuit of harness may be the cause.</p>

## AO:DTC P013B O2 SENSOR SLOW RESPONSE - LEAN TO RICH (BANK 1 SENSOR 2)

NOTE:

For the diagnostic procedure, refer to DTC P013A. <Ref. to EN(H6DO)(diag)-163, DTC P013A O2 SENSOR SLOW RESPONSE - RICH TO LEAN (BANK 1 SENSOR 2), Diagnostic Procedure with Diagnostic Trouble Code (DTC).>

# Diagnostic Procedure with Diagnostic Trouble Code (DTC)

ENGINE (DIAGNOSTICS)

## AP:DTC P013C O2 SENSOR SLOW RESPONSE - RICH TO LEAN (BANK 2 SENSOR 2)

### DTC DETECTING CONDITION:

- Detected when two consecutive driving cycles with fault occur.
- GENERAL DESCRIPTION <Ref. to GD(H6DO)-77, DTC P013C O2 SENSOR SLOW RESPONSE - RICH TO LEAN (BANK 2 SENSOR 2), Diagnostic Trouble Code (DTC) Detecting Criteria.>

### CAUTION:

After servicing or replacing faulty parts, perform Clear Memory Mode <Ref. to EN(H6DO)(diag)-62, OPERATION, Clear Memory Mode.>, and Inspection Mode <Ref. to EN(H6DO)(diag)-47, PROCEDURE, Inspection Mode.>.

### WIRING DIAGRAM:

Engine electrical system <Ref. to WI-32, Engine Electrical System.>

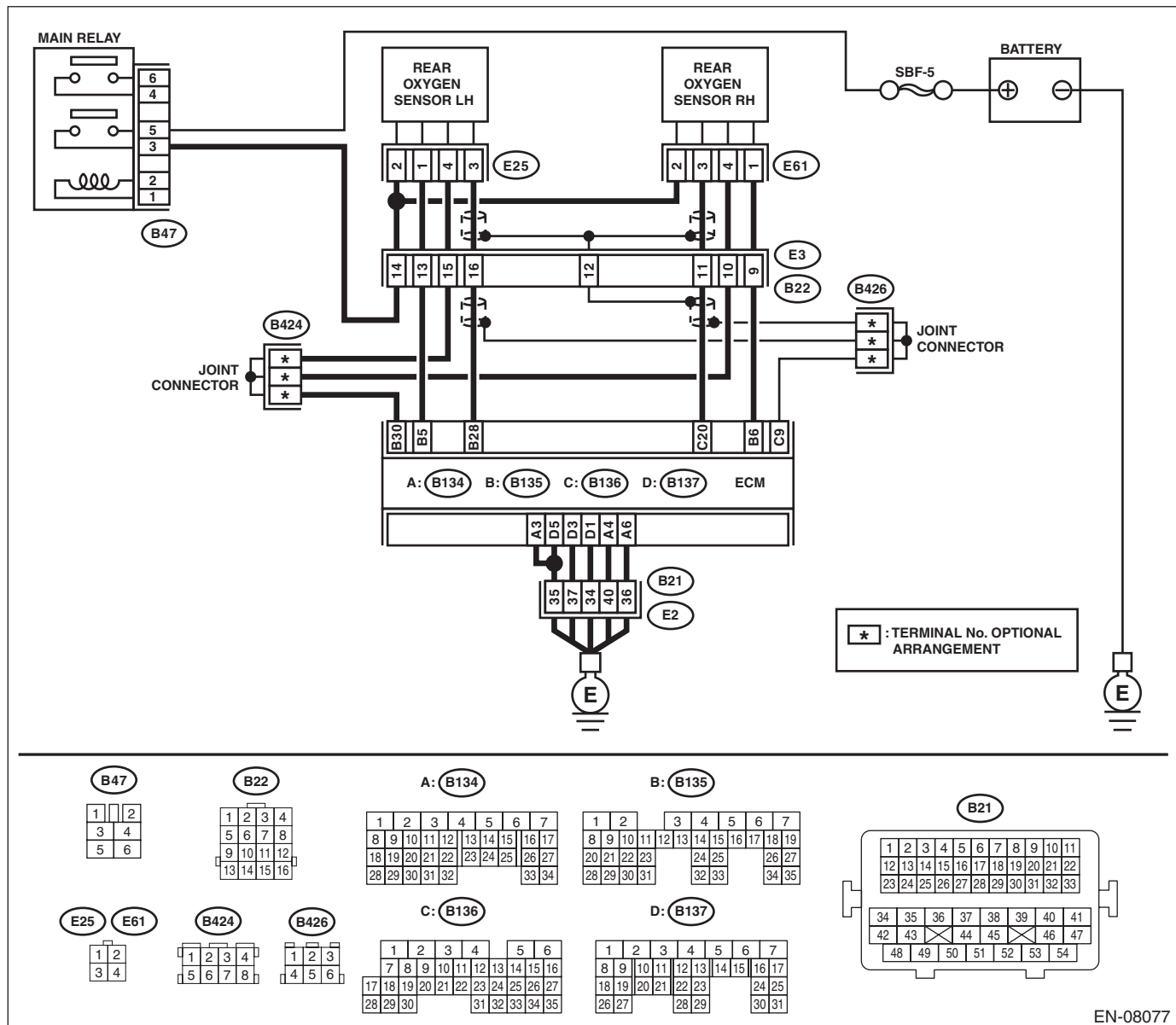

EN-08077

# Diagnostic Procedure with Diagnostic Trouble Code (DTC)

ENGINE (DIAGNOSTICS)

Step	Check	Yes	No
<b>1 CHECK HARNESS BETWEEN ECM AND REAR OXYGEN SENSOR CONNECTOR.</b> 1) Turn the ignition switch to OFF. 2) Disconnect the connector from ECM and rear oxygen sensor. 3) Measure the resistance of harness between ECM and rear oxygen sensor connector. <i><b>Connector &amp; terminal</b></i> <i><b>(B135) No. 28 — (E25) No. 3:</b></i>	Is the resistance less than 1 Ω?	Go to step 2.	Repair the harness and connector.  NOTE: In this case, repair the following item: <ul style="list-style-type: none"> <li>• Open circuit in harness between ECM and rear oxygen sensor connector</li> <li>• Poor contact of coupling connector</li> </ul>
<b>2 CHECK HARNESS BETWEEN ECM AND REAR OXYGEN SENSOR CONNECTOR.</b> Measure the resistance between rear oxygen sensor connector and chassis ground. <i><b>Connector &amp; terminal</b></i> <i><b>(E25) No. 3 — Chassis ground:</b></i>	Is the resistance 1 MΩ or more?	Go to step 3.	Repair the ground short circuit of harness between ECM and rear oxygen sensor connector.
<b>3 CHECK REAR OXYGEN SENSOR.</b> Measure the resistance between rear oxygen sensor terminals. <i><b>Terminals</b></i> <i><b>No. 3 — No. 4</b></i>	Is the resistance less than 1 Ω?	Replace the rear oxygen sensor. <Ref. to FU(H6DO)-50, Rear Oxygen Sensor.>	Even if DTC is detected, the circuit has returned to a normal condition at this time. Reproduce the failure, and then perform the diagnosis again.  NOTE: In this case, temporary poor contact of connector, temporary open or short circuit of harness may be the cause.

## AQ:DTC P013D O2 SENSOR SLOW RESPONSE - LEAN TO RICH (BANK 2 SENSOR 2)

NOTE:

For the diagnostic procedure, refer to DTC P013C. <Ref. to EN(H6DO)(diag)-165, DTC P013C O2 SENSOR SLOW RESPONSE - RICH TO LEAN (BANK 2 SENSOR 2), Diagnostic Procedure with Diagnostic Trouble Code (DTC).>

## AR:DTC P013E O2 SENSOR DELAYED RESPONSE - RICH TO LEAN (BANK 1 SENSOR 2)

NOTE:

For the diagnostic procedure, refer to DTC P013A. <Ref. to EN(H6DO)(diag)-163, DTC P013A O2 SENSOR SLOW RESPONSE - RICH TO LEAN (BANK 1 SENSOR 2), Diagnostic Procedure with Diagnostic Trouble Code (DTC).>

## AS:DTC P013F O2 SENSOR DELAYED RESPONSE - LEAN TO RICH (BANK 1 SENSOR 2)

NOTE:

For the diagnostic procedure, refer to DTC P013A. <Ref. to EN(H6DO)(diag)-163, DTC P013A O2 SENSOR SLOW RESPONSE - RICH TO LEAN (BANK 1 SENSOR 2), Diagnostic Procedure with Diagnostic Trouble Code (DTC).>

# Diagnostic Procedure with Diagnostic Trouble Code (DTC)

ENGINE (DIAGNOSTICS)

## AT:DTC P0140 O2 SENSOR CIRCUIT NO ACTIVITY DETECTED (BANK1 SENSOR2)

### DTC DETECTING CONDITION:

- Detected when two consecutive driving cycles with fault occur.
- GENERAL DESCRIPTION <Ref. to GD(H6DO)-82, DTC P0140 O2 SENSOR CIRCUIT NO ACTIVITY DETECTED (BANK1 SENSOR2), Diagnostic Trouble Code (DTC) Detecting Criteria.>

### CAUTION:

After servicing or replacing faulty parts, perform Clear Memory Mode <Ref. to EN(H6DO)(diag)-62, OPERATION, Clear Memory Mode.>, and Inspection Mode <Ref. to EN(H6DO)(diag)-47, PROCEDURE, Inspection Mode.>.

### WIRING DIAGRAM:

Engine electrical system <Ref. to WI-32, Engine Electrical System.>

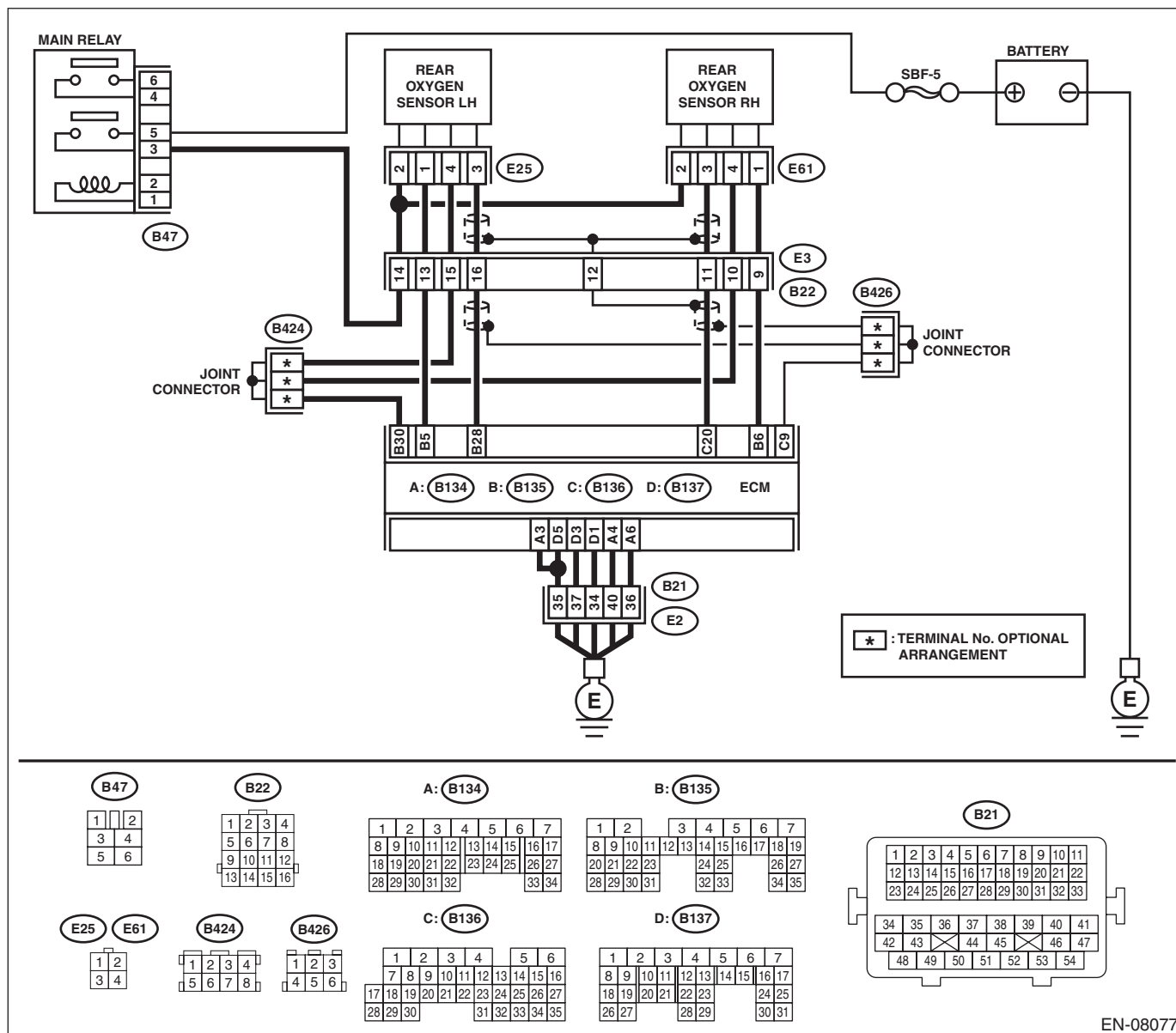

EN-08077

# Diagnostic Procedure with Diagnostic Trouble Code (DTC)

## ENGINE (DIAGNOSTICS)

	Step	Check	Yes	No
1	<p><b>CHECK REAR OXYGEN SENSOR DATA.</b></p> <p>1) Warm up the engine until engine coolant temperature is higher than 75°C (167°F), and keep the engine speed at 3,000 rpm. (2 minutes maximum)</p> <p>2) Read the value of «Front O2 Sensor #1» using the Subaru Select Monitor or a general scan tool.</p> <p>NOTE:</p> <ul style="list-style-type: none"> <li>Subaru Select Monitor</li> </ul> <p>For detailed operation procedures, refer to “READ CURRENT DATA FOR ENGINE”. &lt;Ref. to EN(H6DO)(diag)-37, Subaru Select Monitor.&gt;</p> <ul style="list-style-type: none"> <li>General scan tool</li> </ul> <p>For detailed operation procedures, refer to the general scan tool operation manual.</p>	Is the value of «Front O2 Sensor #1» 0.490 V or more?	Go to step 6.	Go to step 2.
2	<p><b>CHECK REAR OXYGEN SENSOR DATA.</b></p> <p>1) Warm up the engine until engine coolant temperature is higher than 75°C (167°F), and rapidly reduce the engine speed from 3,000 rpm.</p> <p>2) Read the value of «Front O2 Sensor #1» using the Subaru Select Monitor or a general scan tool.</p> <p>NOTE:</p> <ul style="list-style-type: none"> <li>Subaru Select Monitor</li> </ul> <p>For detailed operation procedures, refer to “READ CURRENT DATA FOR ENGINE”. &lt;Ref. to EN(H6DO)(diag)-37, Subaru Select Monitor.&gt;</p> <ul style="list-style-type: none"> <li>General scan tool</li> </ul> <p>For detailed operation procedures, refer to the general scan tool operation manual.</p>	Is the value of «Front O2 Sensor #1» 0.250 V or less?	Go to step 6.	Go to step 3.
3	<p><b>CHECK REAR OXYGEN SENSOR CONNECTOR AND COUPLING CONNECTOR.</b></p>	Has water entered the connector?	Completely remove any water inside.	Go to step 4.
4	<p><b>CHECK HARNESS BETWEEN ECM AND REAR OXYGEN SENSOR CONNECTOR.</b></p> <p>1) Turn the ignition switch to OFF.</p> <p>2) Disconnect the connector from ECM and rear oxygen sensor.</p> <p>3) Measure the resistance of harness between ECM and rear oxygen sensor connector.</p> <p><b>Connector &amp; terminal</b></p> <p><b>(B136) No. 20 — (E61) No. 3:</b></p> <p><b>(B135) No. 30 — (E61) No. 4:</b></p>	Is the resistance less than 1 Ω?	Go to step 5.	<p>Repair the harness and connector.</p> <p>NOTE:</p> <p>In this case, repair the following item:</p> <ul style="list-style-type: none"> <li>Open circuit in harness between ECM and rear oxygen sensor connector</li> <li>Poor contact of coupling connector</li> </ul>

# Diagnostic Procedure with Diagnostic Trouble Code (DTC)

ENGINE (DIAGNOSTICS)

Step	Check	Yes	No
<b>5</b> <b>CHECK HARNESS BETWEEN ECM AND REAR OXYGEN SENSOR CONNECTOR.</b> 1) Connect the connector to ECM. 2) Turn the ignition switch to ON. 3) Measure the voltage between rear oxygen sensor connector and chassis ground. <b>Connector &amp; terminal</b> <b>(E61) No. 3 (+) — Chassis ground (-):</b>	Is the voltage 0.2 — 0.5 V?	Replace the rear oxygen sensor. <Ref. to FU(H6DO)-50, Rear Oxygen Sensor.>	Repair the harness and connector. NOTE: In this case, repair the following item: <ul style="list-style-type: none"> <li>• Open circuit in harness between ECM and rear oxygen sensor connector</li> <li>• Poor contact of ECM connector</li> <li>• Poor contact of coupling connector</li> </ul>
<b>6</b> <b>CHECK EXHAUST SYSTEM.</b> Check exhaust system parts. NOTE: Check the following items. <ul style="list-style-type: none"> <li>• Looseness and improper fitting of exhaust system parts</li> <li>• Damage (crack, hole etc.) of parts</li> <li>• Loose part and improper installation between front oxygen (A/F) sensor and rear oxygen sensor</li> </ul>	Is there any fault in exhaust system?	Repair or replace faulty parts.	Replace the rear oxygen sensor. <Ref. to FU(H6DO)-50, Rear Oxygen Sensor.>

## AU:DTC P0141 O2 SENSOR HEATER CIRCUIT (BANK1 SENSOR2)

NOTE:

Refer to DTC P0037 for diagnostic procedure. <Ref. to EN(H6DO)(diag)-113, DTC P0037 HO2S HEATER CONTROL CIRCUIT LOW (BANK 1 SENSOR 2), Diagnostic Procedure with Diagnostic Trouble Code (DTC).>

## AV:DTC P014A O2 SENSOR DELAYED RESPONSE - RICH TO LEAN (BANK 2 SENSOR 2)

NOTE:

For the diagnostic procedure, refer to DTC P013C. <Ref. to EN(H6DO)(diag)-165, DTC P013C O2 SENSOR SLOW RESPONSE - RICH TO LEAN (BANK 2 SENSOR 2), Diagnostic Procedure with Diagnostic Trouble Code (DTC).>

## AW:DTC P014B O2 SENSOR DELAYED RESPONSE - LEAN TO RICH (BANK 2 SENSOR 2)

NOTE:

For the diagnostic procedure, refer to DTC P013C. <Ref. to EN(H6DO)(diag)-165, DTC P013C O2 SENSOR SLOW RESPONSE - RICH TO LEAN (BANK 2 SENSOR 2), Diagnostic Procedure with Diagnostic Trouble Code (DTC).>

## Diagnostic Procedure with Diagnostic Trouble Code (DTC)

ENGINE (DIAGNOSTICS)

---

### AX:DTC P014C O2 SENSOR SLOW RESPONSE - RICH TO LEAN (BANK 1 SENSOR 1)

#### DTC DETECTING CONDITION:

- Detected when two consecutive driving cycles with fault occur.
- GENERAL DESCRIPTION <Ref. to GD(H6DO)-86, DTC P014C O2 SENSOR SLOW RESPONSE - RICH TO LEAN (BANK 1 SENSOR 1), Diagnostic Trouble Code (DTC) Detecting Criteria.>

#### CAUTION:

After servicing or replacing faulty parts, perform Clear Memory Mode <Ref. to EN(H6DO)(diag)-62, OPERATION, Clear Memory Mode.>, and Inspection Mode <Ref. to EN(H6DO)(diag)-47, PROCEDURE, Inspection Mode.>.

	Step	Check	Yes	No
1	<b>CHECK EXHAUST SYSTEM.</b> NOTE: Check the following items. <ul style="list-style-type: none"><li>• Loose installation of front portion of exhaust pipe onto cylinder heads</li><li>• Loose connection between front exhaust pipe and front catalytic converter</li><li>• Damage of exhaust pipe resulting in a hole</li></ul>	Is there any fault in exhaust system?	Repair the exhaust system.	Replace the front oxygen (A/F) sensor. <Ref. to FU(H6DO)-48, Front Oxygen (A/F) Sensor.>

### AY:DTC P014D O2 SENSOR SLOW RESPONSE - LEAN TO RICH (BANK 1 SENSOR 1)

#### NOTE:

For the diagnostic procedure, refer to DTC P014C. <Ref. to EN(H6DO)(diag)-170, DTC P014C O2 SENSOR SLOW RESPONSE - RICH TO LEAN (BANK 1 SENSOR 1), Diagnostic Procedure with Diagnostic Trouble Code (DTC).>



# Diagnostic Procedure with Diagnostic Trouble Code (DTC)

ENGINE (DIAGNOSTICS)

## AZ:DTC P014E O2 SENSOR SLOW RESPONSE - RICH TO LEAN (BANK 2 SENSOR 1)

### DTC DETECTING CONDITION:

- Detected when two consecutive driving cycles with fault occur.
- GENERAL DESCRIPTION <Ref. to GD(H6DO)-89, DTC P014E O2 SENSOR SLOW RESPONSE - RICH TO LEAN (BANK 2 SENSOR 1), Diagnostic Trouble Code (DTC) Detecting Criteria.>

### CAUTION:

After servicing or replacing faulty parts, perform Clear Memory Mode <Ref. to EN(H6DO)(diag)-62, OPERATION, Clear Memory Mode.>, and Inspection Mode <Ref. to EN(H6DO)(diag)-47, PROCEDURE, Inspection Mode.>.

	Step	Check	Yes	No
1	<b>CHECK EXHAUST SYSTEM.</b> NOTE: Check the following items. <ul style="list-style-type: none"><li>• Loose installation of front portion of exhaust pipe onto cylinder heads</li><li>• Loose connection between front exhaust pipe and front catalytic converter</li><li>• Damage of exhaust pipe resulting in a hole</li></ul>	Is there any fault in exhaust system?	Repair the exhaust system.	Replace the front oxygen (A/F) sensor. <Ref. to FU(H6DO)-48, Front Oxygen (A/F) Sensor.>

## BA:DTC P014F O2 SENSOR SLOW RESPONSE - LEAN TO RICH (BANK 2 SENSOR 1)

### NOTE:

For the diagnostic procedure, refer to DTC P014E. <Ref. to EN(H6DO)(diag)-171, DTC P014E O2 SENSOR SLOW RESPONSE - RICH TO LEAN (BANK 2 SENSOR 1), Diagnostic Procedure with Diagnostic Trouble Code (DTC).>

# Diagnostic Procedure with Diagnostic Trouble Code (DTC)

ENGINE (DIAGNOSTICS)

## BB:DTC P0151 O2 SENSOR CIRCUIT LOW VOLTAGE (BANK 2 SENSOR 1)

### DTC DETECTING CONDITION:

- Immediately at fault recognition
- GENERAL DESCRIPTION <Ref. to GD(H6DO)-89, DTC P0151 O2 SENSOR CIRCUIT LOW VOLTAGE (BANK 2 SENSOR 1), Diagnostic Trouble Code (DTC) Detecting Criteria.>

### CAUTION:

After servicing or replacing faulty parts, perform Clear Memory Mode <Ref. to EN(H6DO)(diag)-62, OPERATION, Clear Memory Mode.>, and Inspection Mode <Ref. to EN(H6DO)(diag)-47, PROCEDURE, Inspection Mode.>.

### WIRING DIAGRAM:

Engine electrical system <Ref. to WI-32, Engine Electrical System.>

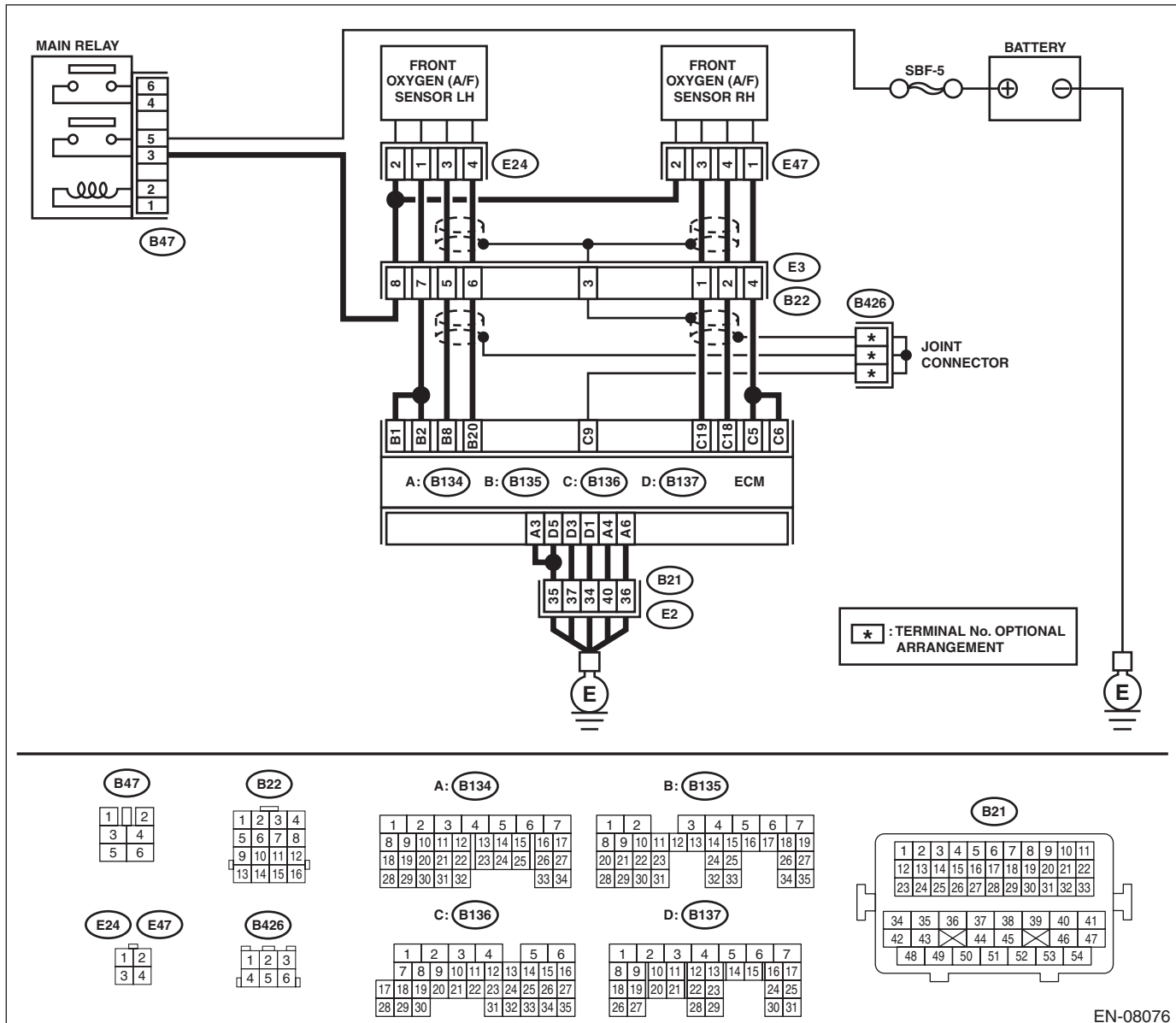

EN-08076

# Diagnostic Procedure with Diagnostic Trouble Code (DTC)

ENGINE (DIAGNOSTICS)

Step	Check	Yes	No
<b>1</b> <b>CHECK FRONT OXYGEN (A/F) SENSOR CONNECTOR AND COUPLING CONNECTOR.</b>	Has water entered the connector?	Completely remove any water inside.	Go to step 2.
<b>2</b> <b>CHECK HARNESS BETWEEN ECM AND FRONT OXYGEN (A/F) SENSOR CONNECTOR.</b> 1) Turn the ignition switch to OFF. 2) Disconnect the connectors from ECM and front oxygen (A/F) sensor connector. 3) Measure the resistance between ECM and chassis ground. <b>Connector &amp; terminal</b> <b>(B135) No. 8 — Chassis ground:</b> <b>(B135) No. 20 — Chassis ground:</b>	Is the resistance 1 MΩ or more?	Go to step 3.	Repair the ground short circuit of harness between ECM and front oxygen (A/F) sensor connector.
<b>3</b> <b>CHECK FOR POOR CONTACT.</b> Check for poor contact of the front oxygen (A/F) sensor connector.	Is there poor contact of front oxygen (A/F) sensor connector?	Repair the poor contact of front oxygen (A/F) sensor connector.	Replace the front oxygen (A/F) sensor. <Ref. to FU(H6DO)-48, Front Oxygen (A/F) Sensor.>

# Diagnostic Procedure with Diagnostic Trouble Code (DTC)

ENGINE (DIAGNOSTICS)

## BC:DTC P0152 O2 SENSOR CIRCUIT HIGH VOLTAGE (BANK 2 SENSOR 1)

### DTC DETECTING CONDITION:

- Immediately at fault recognition
- GENERAL DESCRIPTION <Ref. to GD(H6DO)-89, DTC P0152 O2 SENSOR CIRCUIT HIGH VOLTAGE (BANK 2 SENSOR 1), Diagnostic Trouble Code (DTC) Detecting Criteria.>

### CAUTION:

After servicing or replacing faulty parts, perform Clear Memory Mode <Ref. to EN(H6DO)(diag)-62, OPERATION, Clear Memory Mode.>, and Inspection Mode <Ref. to EN(H6DO)(diag)-47, PROCEDURE, Inspection Mode.>.

### WIRING DIAGRAM:

Engine electrical system <Ref. to WI-32, Engine Electrical System.>

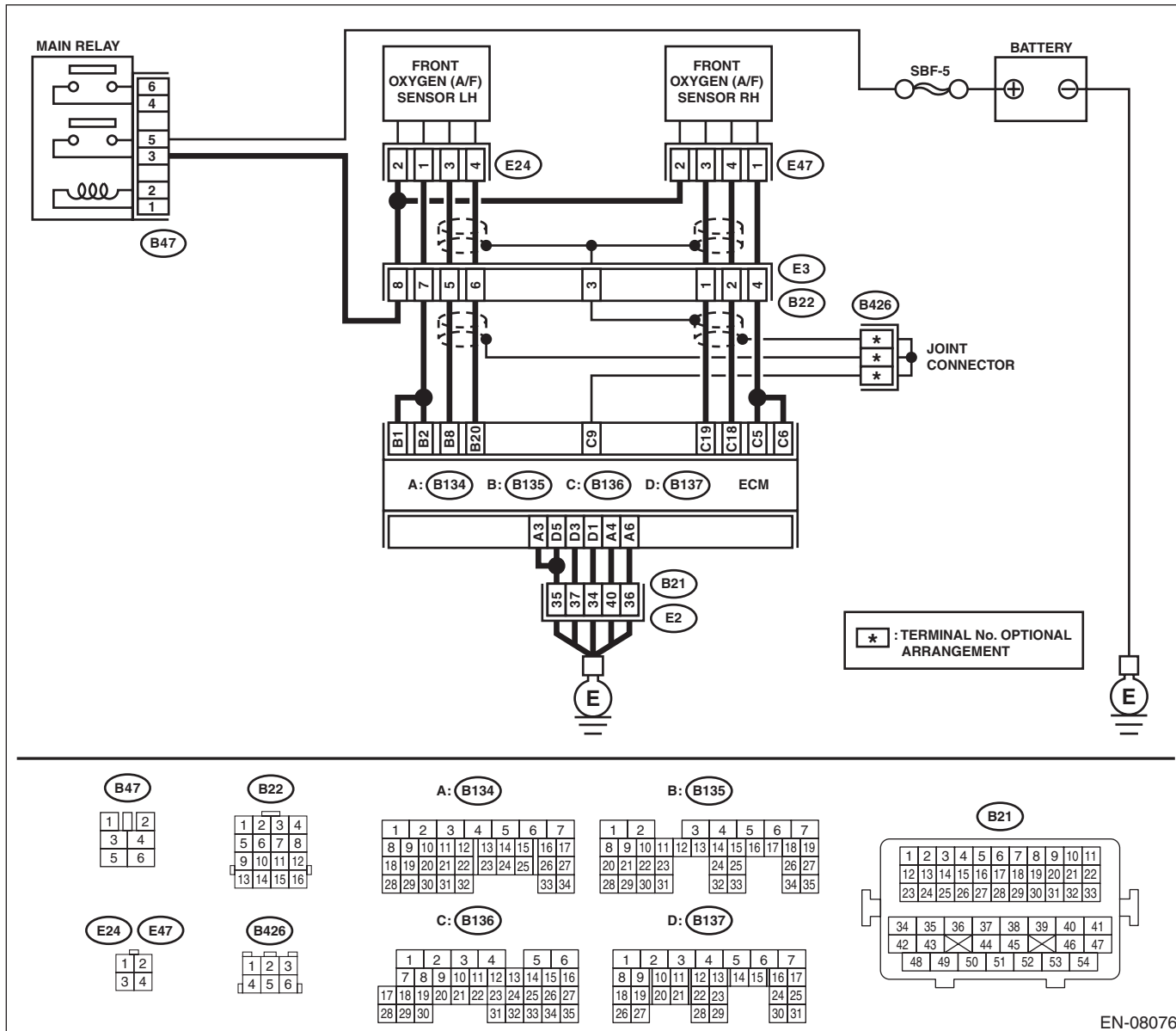

EN-08076

# Diagnostic Procedure with Diagnostic Trouble Code (DTC)

ENGINE (DIAGNOSTICS)

	Step	Check	Yes	No
1	<b>CHECK FRONT OXYGEN (A/F) SENSOR CONNECTOR AND COUPLING CONNECTOR.</b>	Has water entered the connector?	Completely remove any water inside.	Go to step 2.
2	<b>CHECK HARNESS BETWEEN ECM AND FRONT OXYGEN (A/F) SENSOR CONNECTOR.</b> 1) Turn the ignition switch to OFF. 2) Disconnect the connectors from front oxygen (A/F) sensor. 3) Turn the ignition switch to ON. 4) Measure the voltage between ECM and chassis ground. <b>Connector &amp; terminal</b> <b>(B135) No. 8 (+) — Chassis ground (-):</b> <b>(B135) No. 20 (+) — Chassis ground (-):</b>	Is the voltage 8 V or more?	Repair the short circuit to power in the harness between ECM and front oxygen (A/F) sensor connector.	Replace the front oxygen (A/F) sensor. <Ref. to FU(H6DO)-48, Front Oxygen (A/F) Sensor.>

# Diagnostic Procedure with Diagnostic Trouble Code (DTC)

ENGINE (DIAGNOSTICS)

## BD:DTC P0154 O2 SENSOR CIRCUIT NO ACTIVITY DETECTED (BANK 2 SENSOR 1)

### DTC DETECTING CONDITION:

- Immediately at fault recognition
- GENERAL DESCRIPTION <Ref. to GD(H6DO)-89, DTC P0154 O2 SENSOR CIRCUIT NO ACTIVITY DETECTED (BANK 2 SENSOR 1), Diagnostic Trouble Code (DTC) Detecting Criteria.>

### CAUTION:

After servicing or replacing faulty parts, perform Clear Memory Mode <Ref. to EN(H6DO)(diag)-62, OPERATION, Clear Memory Mode.>, and Inspection Mode <Ref. to EN(H6DO)(diag)-47, PROCEDURE, Inspection Mode.>.

### WIRING DIAGRAM:

Engine electrical system <Ref. to WI-32, Engine Electrical System.>

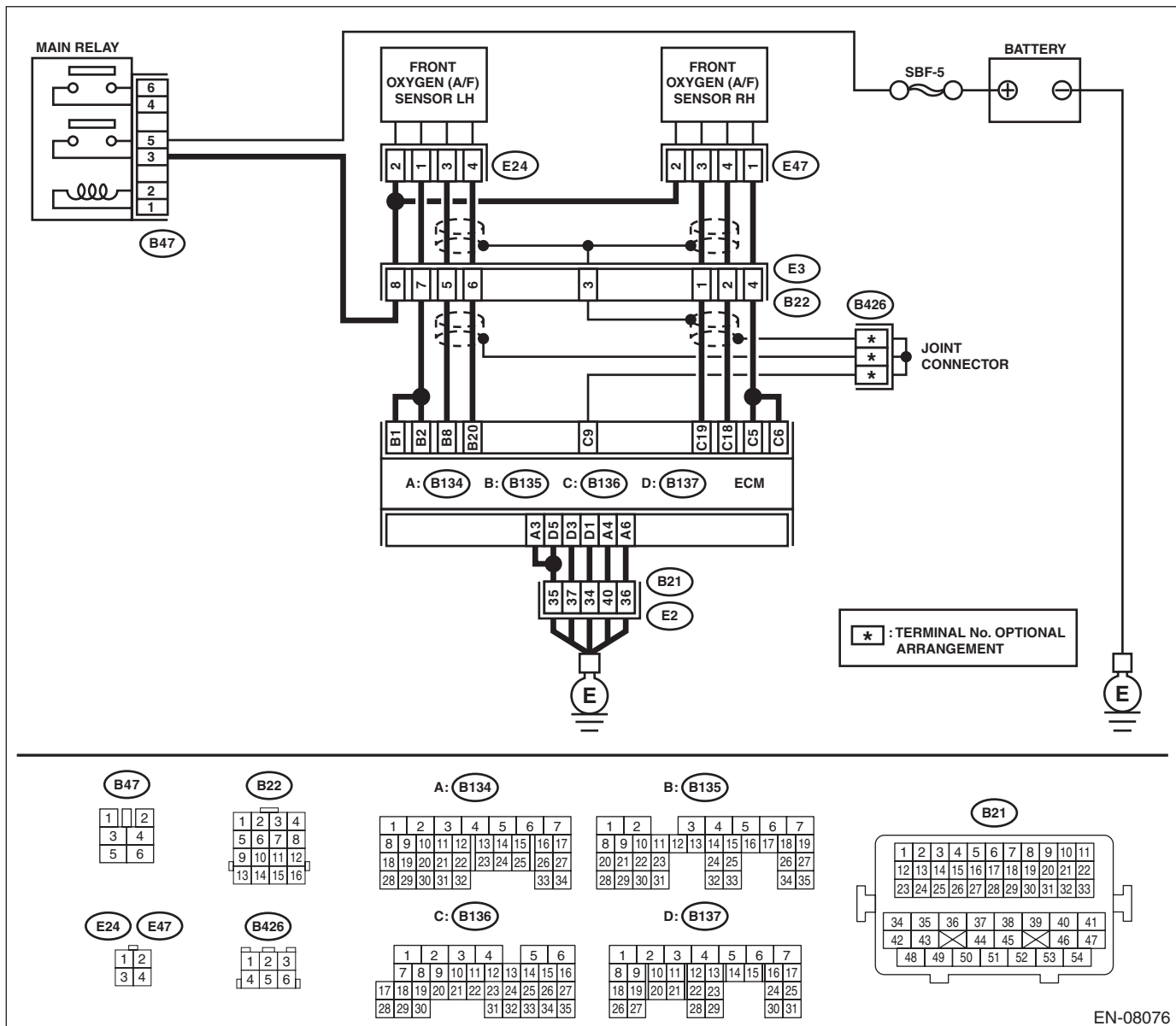

EN-08076

# Diagnostic Procedure with Diagnostic Trouble Code (DTC)

ENGINE (DIAGNOSTICS)

Step	Check	Yes	No
<p><b>1</b>     <b>CHECK HARNESS BETWEEN ECM AND FRONT OXYGEN (A/F) SENSOR CONNECTOR.</b></p> <p>1) Turn the ignition switch to OFF.            2) Disconnect the connectors from ECM and front oxygen (A/F) sensor connector.            3) Measure the resistance of harness between ECM and front oxygen (A/F) sensor connector.</p> <p><b>Connector &amp; terminal</b>  <b>(B135) No. 8 — (E24) No. 3:</b>  <b>(B135) No. 20 — (E24) No. 4:</b></p>	<p>Is the resistance less than 1 Ω?</p>	<p>Go to step 2.</p>	<p>Repair the harness and connector.</p> <p>NOTE:            In this case, repair the following item:</p> <ul style="list-style-type: none"> <li>• Open circuit in harness between ECM and front oxygen (A/F) sensor connector</li> <li>• Poor contact of coupling connector</li> </ul>
<p><b>2</b>     <b>CHECK FOR POOR CONTACT.</b>            Check for poor contact of ECM and front oxygen (A/F) sensor connector.</p>	<p>Is there poor contact of ECM or front oxygen (A/F) sensor connector?</p>	<p>Repair the poor contact of ECM or front oxygen (A/F) sensor connector.</p>	<p>Replace the front oxygen (A/F) sensor. &lt;Ref. to FU(H6DO)-48, Front Oxygen (A/F) Sensor.&gt;</p>

# Diagnostic Procedure with Diagnostic Trouble Code (DTC)

ENGINE (DIAGNOSTICS)

## BE:DTC P0157 O2 SENSOR CIRCUIT LOW VOLTAGE (BANK 2 SENSOR 2)

### DTC DETECTING CONDITION:

- Detected when two consecutive driving cycles with fault occur.
- GENERAL DESCRIPTION <Ref. to GD(H6DO)-89, DTC P0157 O2 SENSOR CIRCUIT LOW VOLTAGE (BANK 2 SENSOR 2), Diagnostic Trouble Code (DTC) Detecting Criteria.>

### CAUTION:

After servicing or replacing faulty parts, perform Clear Memory Mode <Ref. to EN(H6DO)(diag)-62, OPERATION, Clear Memory Mode.>, and Inspection Mode <Ref. to EN(H6DO)(diag)-47, PROCEDURE, Inspection Mode.>.

### WIRING DIAGRAM:

Engine electrical system <Ref. to WI-32, Engine Electrical System.>

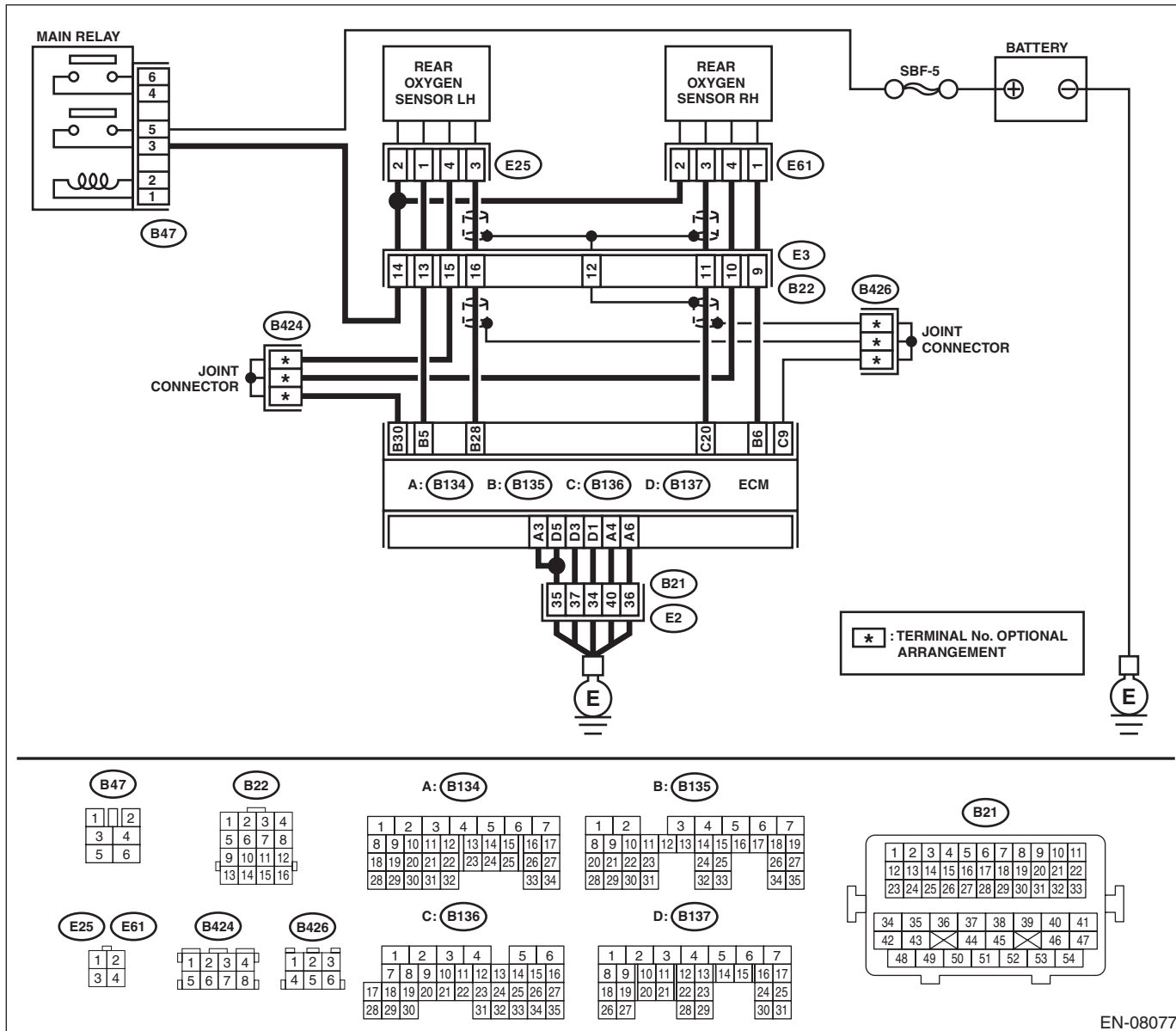

EN-08077



# Diagnostic Procedure with Diagnostic Trouble Code (DTC)

ENGINE (DIAGNOSTICS)

Step	Check	Yes	No
<p><b>1 CHECK REAR OXYGEN SENSOR DATA.</b>                      1) Warm up the engine until engine coolant temperature is higher than 75°C (167°F), and keep the engine speed at 3,000 rpm. (2 minutes maximum)                      2) Read the value of «Front O2 Sensor #2» using the Subaru Select Monitor or a general scan tool.                      NOTE:                      • Subaru Select Monitor                      For detailed operation procedures, refer to “READ CURRENT DATA FOR ENGINE”. &lt;Ref. to EN(H6DO)(diag)-37, Subaru Select Monitor.&gt;                      • General scan tool                      For detailed operation procedures, refer to the general scan tool operation manual.</p>	<p>Is the value of «Front O2 Sensor #2» 0.490 V or more?</p>	<p>Go to step 5.</p>	<p>Go to step 2.</p>
<p><b>2 CHECK REAR OXYGEN SENSOR CONNECTOR AND COUPLING CONNECTOR.</b></p>	<p>Has water entered the connector?</p>	<p>Completely remove any water inside.</p>	<p>Go to step 3.</p>
<p><b>3 CHECK HARNESS BETWEEN ECM AND REAR OXYGEN SENSOR CONNECTOR.</b>                      1) Turn the ignition switch to OFF.                      2) Disconnect the connector from ECM and rear oxygen sensor.                      3) Measure the resistance of harness between ECM and rear oxygen sensor connector.  <i>Connector &amp; terminal</i>  <i>(B135) No. 28 — (E25) No. 3:</i>  <i>(B135) No. 30 — (E25) No. 4:</i></p>	<p>Is the resistance less than 1 Ω?</p>	<p>Go to step 4.</p>	<p>Repair the harness and connector.                      NOTE:                      In this case, repair the following item:                      • Open circuit in harness between ECM and rear oxygen sensor connector                      • Poor contact of coupling connector</p>
<p><b>4 CHECK HARNESS BETWEEN ECM AND REAR OXYGEN SENSOR CONNECTOR.</b>                      1) Connect the connector to ECM.                      2) Turn the ignition switch to ON.                      3) Measure the voltage between rear oxygen sensor connector and chassis ground.  <i>Connector &amp; terminal</i>  <i>(E25) No. 3 (+) — Chassis ground (-):</i></p>	<p>Is the voltage 0.2 — 0.5 V?</p>	<p>Replace the rear oxygen sensor.                      &lt;Ref. to FU(H6DO)-50, Rear Oxygen Sensor.&gt;</p>	<p>Repair the harness and connector.                      NOTE:                      In this case, repair the following item:                      • Open circuit in harness between ECM and rear oxygen sensor connector                      • Poor contact of ECM connector                      • Poor contact of coupling connector</p>
<p><b>5 CHECK EXHAUST SYSTEM.</b>                      Check exhaust system parts.                      NOTE:                      Check the following items.                      • Looseness and improper fitting of exhaust system parts                      • Damage (crack, hole etc.) of parts                      • Loose part and improper installation between front oxygen (A/F) sensor and rear oxygen sensor</p>	<p>Is there any fault in exhaust system?</p>	<p>Repair or replace faulty parts.</p>	<p>Replace the rear oxygen sensor.                      &lt;Ref. to FU(H6DO)-50, Rear Oxygen Sensor.&gt;</p>

# Diagnostic Procedure with Diagnostic Trouble Code (DTC)

ENGINE (DIAGNOSTICS)

## BF:DTC P0158 O2 SENSOR CIRCUIT HIGH VOLTAGE (BANK 2 SENSOR 2)

### DTC DETECTING CONDITION:

- Detected when two consecutive driving cycles with fault occur.
- GENERAL DESCRIPTION <Ref. to GD(H6DO)-89, DTC P0158 O2 SENSOR CIRCUIT HIGH VOLTAGE (BANK 2 SENSOR 2), Diagnostic Trouble Code (DTC) Detecting Criteria.>

### CAUTION:

After servicing or replacing faulty parts, perform Clear Memory Mode <Ref. to EN(H6DO)(diag)-62, OPERATION, Clear Memory Mode.>, and Inspection Mode <Ref. to EN(H6DO)(diag)-47, PROCEDURE, Inspection Mode.>.

### WIRING DIAGRAM:

Engine electrical system <Ref. to WI-32, Engine Electrical System.>

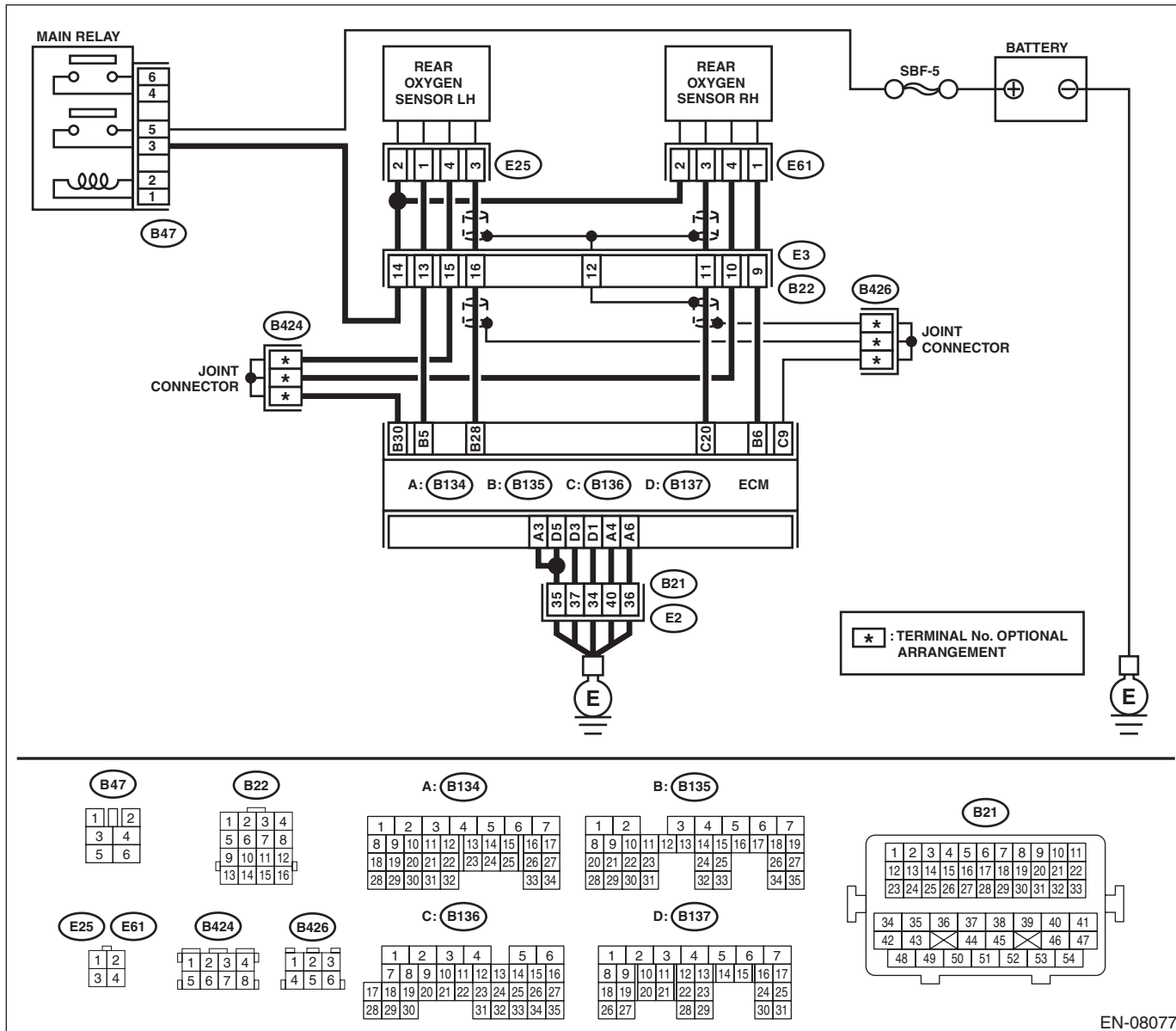

EN-08077

# Diagnostic Procedure with Diagnostic Trouble Code (DTC)

ENGINE (DIAGNOSTICS)

Step	Check	Yes	No
<b>1 CHECK REAR OXYGEN SENSOR DATA.</b> 1) Warm up the engine until engine coolant temperature is higher than 75°C (167°F), and rapidly reduce the engine speed from 3,000 rpm. 2) Read the value of «Front O2 Sensor #2» using the Subaru Select Monitor or a general scan tool. NOTE: • Subaru Select Monitor For detailed operation procedures, refer to “READ CURRENT DATA FOR ENGINE”. <Ref. to EN(H6DO)(diag)-37, Subaru Select Monitor.> • General scan tool For detailed operation procedures, refer to the general scan tool operation manual.	Is the value of «Front O2 Sensor #2» 0.250 V or less?	Go to step 5.	Go to step 2.
<b>2 CHECK REAR OXYGEN SENSOR CONNECTOR AND COUPLING CONNECTOR.</b>	Has water entered the connector?	Completely remove any water inside.	Go to step 3.
<b>3 CHECK HARNESS BETWEEN ECM AND REAR OXYGEN SENSOR CONNECTOR.</b> 1) Turn the ignition switch to OFF. 2) Disconnect the connector from ECM and rear oxygen sensor. 3) Measure the resistance of harness between ECM and rear oxygen sensor connector. <i>Connector &amp; terminal</i> <i>(B135) No. 28 — (E25) No. 3:</i> <i>(B135) No. 30 — (E25) No. 4:</i>	Is the resistance less than 1 Ω?	Go to step 4.	Repair the harness and connector. NOTE: In this case, repair the following item: • Open circuit in harness between ECM and rear oxygen sensor connector • Poor contact of coupling connector
<b>4 CHECK HARNESS BETWEEN ECM AND REAR OXYGEN SENSOR CONNECTOR.</b> 1) Connect the connector to ECM. 2) Turn the ignition switch to ON. 3) Measure the voltage between rear oxygen sensor connector and chassis ground. <i>Connector &amp; terminal</i> <i>(E25) No. 3 (+) — Chassis ground (-):</i>	Is the voltage 0.2 — 0.5 V?	Replace the rear oxygen sensor. <Ref. to FU(H6DO)-50, Rear Oxygen Sensor.>	Repair the harness and connector. NOTE: In this case, repair the following item: • Open circuit in harness between ECM and rear oxygen sensor connector • Poor contact of ECM connector • Poor contact of coupling connector
<b>5 CHECK EXHAUST SYSTEM.</b> Check exhaust system parts. NOTE: Check the following items. • Looseness and improper fitting of exhaust system parts • Damage (crack, hole etc.) of parts • Loose part and improper installation between front oxygen (A/F) sensor and rear oxygen sensor	Is there any fault in exhaust system?	Repair or replace faulty parts.	Replace the rear oxygen sensor. <Ref. to FU(H6DO)-50, Rear Oxygen Sensor.>

## Diagnostic Procedure with Diagnostic Trouble Code (DTC)

ENGINE (DIAGNOSTICS)

---

### **BG:DTC P015A O2 SENSOR DELAYED RESPONSE - RICH TO LEAN (BANK 1 SENSOR 1)**

NOTE:

For the diagnostic procedure, refer to DTC P014C. <Ref. to EN(H6DO)(diag)-170, DTC P014C O2 SENSOR SLOW RESPONSE - RICH TO LEAN (BANK 1 SENSOR 1), Diagnostic Procedure with Diagnostic Trouble Code (DTC).>

### **BH:DTC P015B O2 SENSOR DELAYED RESPONSE - LEAN TO RICH (BANK 1 SENSOR 1)**

NOTE:

For the diagnostic procedure, refer to DTC P014C. <Ref. to EN(H6DO)(diag)-170, DTC P014C O2 SENSOR SLOW RESPONSE - RICH TO LEAN (BANK 1 SENSOR 1), Diagnostic Procedure with Diagnostic Trouble Code (DTC).>

### **BI: DTC P015C O2 SENSOR DELAYED RESPONSE - RICH TO LEAN (BANK 2 SENSOR 1)**

NOTE:

For the diagnostic procedure, refer to DTC P014E. <Ref. to EN(H6DO)(diag)-171, DTC P014E O2 SENSOR SLOW RESPONSE - RICH TO LEAN (BANK 2 SENSOR 1), Diagnostic Procedure with Diagnostic Trouble Code (DTC).>

### **BJ:DTC P015D O2 SENSOR DELAYED RESPONSE - LEAN TO RICH (BANK 2 SENSOR 1)**

NOTE:

For the diagnostic procedure, refer to DTC P014E. <Ref. to EN(H6DO)(diag)-171, DTC P014E O2 SENSOR SLOW RESPONSE - RICH TO LEAN (BANK 2 SENSOR 1), Diagnostic Procedure with Diagnostic Trouble Code (DTC).>

## BK:DTC P0160 O2 SENSOR CIRCUIT NO ACTIVITY DETECTED (BANK2 SENSOR2)

### DTC DETECTING CONDITION:

- Detected when two consecutive driving cycles with fault occur.
- GENERAL DESCRIPTION <Ref. to GD(H6DO)-94, DTC P0160 O2 SENSOR CIRCUIT NO ACTIVITY DETECTED (BANK2 SENSOR2), Diagnostic Trouble Code (DTC) Detecting Criteria.>

### CAUTION:

**After servicing or replacing faulty parts, perform Clear Memory Mode <Ref. to EN(H6DO)(diag)-62, OPERATION, Clear Memory Mode.>, and Inspection Mode <Ref. to EN(H6DO)(diag)-47, PROCEDURE, Inspection Mode.>.**

### WIRING DIAGRAM:

Engine electrical system <Ref. to WI-32, Engine Electrical System.>

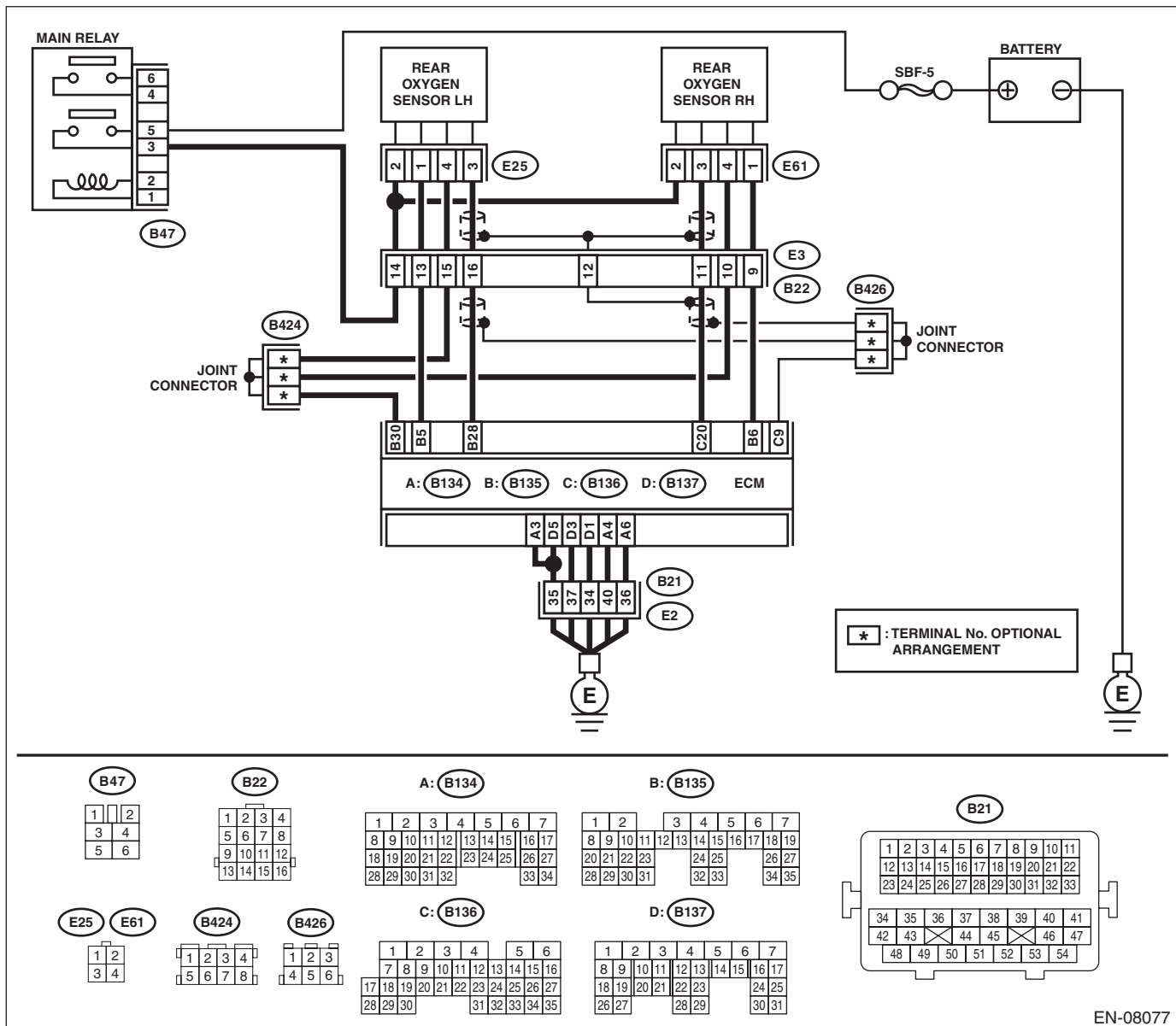

EN-08077

# Diagnostic Procedure with Diagnostic Trouble Code (DTC)

## ENGINE (DIAGNOSTICS)

Step	Check	Yes	No
<p><b>1 CHECK REAR OXYGEN SENSOR DATA.</b>                      1) Warm up the engine until engine coolant temperature is higher than 75°C (167°F), and keep the engine speed at 3,000 rpm. (2 minutes maximum)                      2) Read the value of «Front O2 Sensor #2» using the Subaru Select Monitor or a general scan tool.</p> <p>NOTE:                      • Subaru Select Monitor                      For detailed operation procedures, refer to “READ CURRENT DATA FOR ENGINE”. &lt;Ref. to EN(H6DO)(diag)-37, Subaru Select Monitor.&gt;                      • General scan tool                      For detailed operation procedures, refer to the general scan tool operation manual.</p>	Is the value of «Front O2 Sensor #2» 0.490 V or more?	Go to step 6.	Go to step 2.
<p><b>2 CHECK REAR OXYGEN SENSOR DATA.</b>                      1) Warm up the engine until engine coolant temperature is higher than 75°C (167°F), and rapidly reduce the engine speed from 3,000 rpm.                      2) Read the value of «Front O2 Sensor #2» using the Subaru Select Monitor or a general scan tool.</p> <p>NOTE:                      • Subaru Select Monitor                      For detailed operation procedures, refer to “READ CURRENT DATA FOR ENGINE”. &lt;Ref. to EN(H6DO)(diag)-37, Subaru Select Monitor.&gt;                      • General scan tool                      For detailed operation procedures, refer to the general scan tool operation manual.</p>	Is the value of «Front O2 Sensor #2» 0.250 V or less?	Go to step 6.	Go to step 3.
<p><b>3 CHECK REAR OXYGEN SENSOR CONNECTOR AND COUPLING CONNECTOR.</b></p>	Has water entered the connector?	Completely remove any water inside.	Go to step 4.
<p><b>4 CHECK HARNESS BETWEEN ECM AND REAR OXYGEN SENSOR CONNECTOR.</b>                      1) Turn the ignition switch to OFF.                      2) Disconnect the connector from ECM and rear oxygen sensor.                      3) Measure the resistance of harness between ECM and rear oxygen sensor connector.</p> <p><b>Connector &amp; terminal</b>                      (B135) No. 28 — (E25) No. 3:                      (B135) No. 30 — (E25) No. 4:</p>	Is the resistance less than 1 Ω?	Go to step 5.	Repair the harness and connector. NOTE: In this case, repair the following item: • Open circuit in harness between ECM and rear oxygen sensor connector • Poor contact of coupling connector

# Diagnostic Procedure with Diagnostic Trouble Code (DTC)

ENGINE (DIAGNOSTICS)

Step	Check	Yes	No
<b>5</b> <b>CHECK HARNESS BETWEEN ECM AND REAR OXYGEN SENSOR CONNECTOR.</b> 1) Connect the connector to ECM. 2) Turn the ignition switch to ON. 3) Measure the voltage between rear oxygen sensor connector and chassis ground. <b>Connector &amp; terminal</b> <b>(E25) No. 3 (+) — Chassis ground (-):</b>	Is the voltage 0.2 — 0.5 V?	Replace the rear oxygen sensor. <Ref. to FU(H6DO)-50, Rear Oxygen Sensor.>	Repair the harness and connector. NOTE: In this case, repair the following item: <ul style="list-style-type: none"> <li>• Open circuit in harness between ECM and rear oxygen sensor connector</li> <li>• Poor contact of ECM connector</li> <li>• Poor contact of coupling connector</li> </ul>
<b>6</b> <b>CHECK EXHAUST SYSTEM.</b> Check exhaust system parts. NOTE: Check the following items. <ul style="list-style-type: none"> <li>• Looseness and improper fitting of exhaust system parts</li> <li>• Damage (crack, hole etc.) of parts</li> <li>• Loose part and improper installation between front oxygen (A/F) sensor and rear oxygen sensor</li> </ul>	Is there any fault in exhaust system?	Repair or replace faulty parts.	Replace the rear oxygen sensor. <Ref. to FU(H6DO)-50, Rear Oxygen Sensor.>

## BL:DTC P0161 O2 SENSOR HEATER CIRCUIT (BANK2 SENSOR2)

NOTE:

Refer to DTC P0057 for diagnostic procedure. <Ref. to EN(H6DO)(diag)-123, DTC P0057 HO2S HEATER CONTROL CIRCUIT LOW (BANK 2 SENSOR 2), Diagnostic Procedure with Diagnostic Trouble Code (DTC).>

## BM:DTC P0171 SYSTEM TOO LEAN (BANK 1)

NOTE:

Refer to DTC P0175 for diagnostic procedure. <Ref. to EN(H6DO)(diag)-186, DTC P0175 SYSTEM TOO RICH (BANK 2), Diagnostic Procedure with Diagnostic Trouble Code (DTC).>

## BN:DTC P0172 SYSTEM TOO RICH (BANK 1)

NOTE:

Refer to DTC P0175 for diagnostic procedure. <Ref. to EN(H6DO)(diag)-186, DTC P0175 SYSTEM TOO RICH (BANK 2), Diagnostic Procedure with Diagnostic Trouble Code (DTC).>

## BO:DTC P0174 SYSTEM TOO LEAN (BANK 2)

NOTE:

Refer to DTC P0175 for diagnostic procedure. <Ref. to EN(H6DO)(diag)-186, DTC P0175 SYSTEM TOO RICH (BANK 2), Diagnostic Procedure with Diagnostic Trouble Code (DTC).>

# Diagnostic Procedure with Diagnostic Trouble Code (DTC)

ENGINE (DIAGNOSTICS)

## BP:DTC P0175 SYSTEM TOO RICH (BANK 2)

### DTC DETECTING CONDITION:

- Detected when two consecutive driving cycles with fault occur.
- GENERAL DESCRIPTION <Ref. to GD(H6DO)-97, DTC P0175 SYSTEM TOO RICH (BANK 2), Diagnostic Trouble Code (DTC) Detecting Criteria.>

### TROUBLE SYMPTOM:

- Improper idling
- Engine stalls.
- Poor driving performance

### CAUTION:

After servicing or replacing faulty parts, perform Clear Memory Mode <Ref. to EN(H6DO)(diag)-62, OPERATION, Clear Memory Mode.>, and Inspection Mode <Ref. to EN(H6DO)(diag)-47, PROCEDURE, Inspection Mode.>.

Step	Check	Yes	No
1	<b>CHECK EXHAUST SYSTEM.</b>	Are there holes or loose bolts on exhaust system?	Repair the exhaust system. Go to step 2.
2	<b>CHECK AIR INTAKE SYSTEM.</b>	Are there holes, loose bolts or disconnection of hose on air intake system?	Repair the air intake system. Go to step 3.
3	<b>CHECK FUEL PRESSURE.</b> <b>WARNING:</b> Place "NO OPEN FLAMES" signs near the working area. <b>CAUTION:</b> Be careful not to spill fuel. Measure the fuel pressure. <Ref. to ME(H6DO)-31, INSPECTION, Fuel Pressure.> <b>CAUTION:</b> Release fuel pressure before removing the fuel pressure gauge.	Is the measured value 340 — 400 kPa (3.5 — 4.1 kgf/cm <sup>2</sup> , 49 — 58 psi)?	Go to step 4.  Repair the following item. Fuel pressure is too high: • Clogged fuel line or bent hose Fuel pressure is too low: • Improper fuel pump discharge • Clogged fuel line
4	<b>CHECK ENGINE COOLANT TEMPERATURE SENSOR.</b> 1) Start the engine and warm up completely. 2) Read the value of «Coolant Temp.» using the Subaru Select Monitor or a general scan tool. <b>NOTE:</b> • Subaru Select Monitor For detailed operation procedures, refer to "READ CURRENT DATA FOR ENGINE". <Ref. to EN(H6DO)(diag)-37, Subaru Select Monitor.> • General scan tool For detailed operation procedures, refer to the general scan tool operation manual.	Is the value of «Coolant Temp.» 75°C (167°F) or more?	Go to step 5.  Replace the engine coolant temperature sensor. <Ref. to FU(H6DO)-30, Engine Coolant Temperature Sensor.>



# Diagnostic Procedure with Diagnostic Trouble Code (DTC)

ENGINE (DIAGNOSTICS)

Step	Check	Yes	No
<p><b>5</b></p> <p><b>CHECK MASS AIR FLOW AND INTAKE AIR TEMPERATURE SENSOR SIGNAL.</b></p> <ol style="list-style-type: none"> <li>1) Start the engine and warm up engine until coolant temperature is higher than 75°C (167°F).</li> <li>2) Place the select lever in “P” range or “N” range.</li> <li>3) Turn the A/C switch to OFF.</li> <li>4) Turn all the accessory switches to OFF.</li> <li>5) Read the value of «Mass Air Flow» using the Subaru Select Monitor or a general scan tool.</li> </ol> <p>NOTE:</p> <ul style="list-style-type: none"> <li>• Subaru Select Monitor</li> </ul> <p>For detailed operation procedures, refer to “READ CURRENT DATA FOR ENGINE”. &lt;Ref. to EN(H6DO)(diag)-37, Subaru Select Monitor.&gt;</p> <ul style="list-style-type: none"> <li>• General scan tool</li> </ul> <p>For detailed operation procedures, refer to the general scan tool operation manual.</p>	<p>Is the value of «Mass Air Flow» 2.0 — 5.0 g/s (0.26 — 0.66 lb/m)?</p>	<p>Go to step 6.</p>	<p>Replace the mass air flow and intake air temperature sensor. &lt;Ref. to FU(H6DO)-40, Mass Air Flow and Intake Air Temperature Sensor.&gt;</p>
<p><b>6</b></p> <p><b>CHECK MASS AIR FLOW AND INTAKE AIR TEMPERATURE SENSOR.</b></p> <ol style="list-style-type: none"> <li>1) Start the engine and warm up engine until coolant temperature is higher than 75°C (167°F).</li> <li>2) Place the select lever in “P” range or “N” range.</li> <li>3) Turn the A/C switch to OFF.</li> <li>4) Turn all the accessory switches to OFF.</li> <li>5) Open the front hood.</li> <li>6) Measure the ambient temperature.</li> <li>7) Read the value of «Intake Air Temp.» using the Subaru Select Monitor or a general scan tool.</li> </ol> <p>NOTE:</p> <ul style="list-style-type: none"> <li>• Subaru Select Monitor</li> </ul> <p>For detailed operation procedures, refer to “READ CURRENT DATA FOR ENGINE”. &lt;Ref. to EN(H6DO)(diag)-37, Subaru Select Monitor.&gt;</p> <ul style="list-style-type: none"> <li>• General scan tool</li> </ul> <p>For detailed operation procedures, refer to the general scan tool operation manual.</p>	<p>Subtract ambient temperature from «Intake Air Temp.». Is the obtained value -10 — 50°C (-18 — 90°F)?</p>	<p>Repair the poor contact of ECM connector.</p>	<p>Check the mass air flow and intake air temperature sensor. &lt;Ref. to FU(H6DO)-40, Mass Air Flow and Intake Air Temperature Sensor.&gt;</p>

# Diagnostic Procedure with Diagnostic Trouble Code (DTC)

ENGINE (DIAGNOSTICS)

## BQ:DTC P0196 ENGINE OIL TEMPERATURE SENSOR CIRCUIT RANGE/PERFORMANCE

### DTC DETECTING CONDITION:

- Detected when two consecutive driving cycles with fault occur.
- GENERAL DESCRIPTION <Ref. to GD(H6DO)-98, DTC P0196 ENGINE OIL TEMPERATURE SENSOR CIRCUIT RANGE/PERFORMANCE, Diagnostic Trouble Code (DTC) Detecting Criteria.>

### TROUBLE SYMPTOM:

- Hard to start
- Improper idling
- Poor driving performance

### CAUTION:

After servicing or replacing faulty parts, perform Clear Memory Mode <Ref. to EN(H6DO)(diag)-62, OPERATION, Clear Memory Mode.>, and Inspection Mode <Ref. to EN(H6DO)(diag)-47, PROCEDURE, Inspection Mode.>.

Step	Check	Yes	No
1 CHECK FOR ANY OTHER DTC ON DISPLAY.	Is any other DTC displayed?	Check the appropriate DTC using the "List of Diagnostic Trouble Code (DTC)". <Ref. to EN(H6DO)(diag)-89, List of Diagnostic Trouble Code (DTC).>	Replace the engine oil temperature sensor. <Ref. to FU(H6DO)-47, Oil Temperature Sensor.>

# Diagnostic Procedure with Diagnostic Trouble Code (DTC)

ENGINE (DIAGNOSTICS)

## BR:DTC P0197 ENGINE OIL TEMPERATURE SENSOR LOW

### DTC DETECTING CONDITION:

- Immediately at fault recognition
- GENERAL DESCRIPTION <Ref. to GD(H6DO)-100, DTC P0197 ENGINE OIL TEMPERATURE SENSOR LOW, Diagnostic Trouble Code (DTC) Detecting Criteria.>

### TROUBLE SYMPTOM:

- Hard to start
- Improper idling
- Poor driving performance

### CAUTION:

After servicing or replacing faulty parts, perform Clear Memory Mode <Ref. to EN(H6DO)(diag)-62, OPERATION, Clear Memory Mode.>, and Inspection Mode <Ref. to EN(H6DO)(diag)-47, PROCEDURE, Inspection Mode.>.

### WIRING DIAGRAM:

Engine electrical system <Ref. to WI-32, Engine Electrical System.>

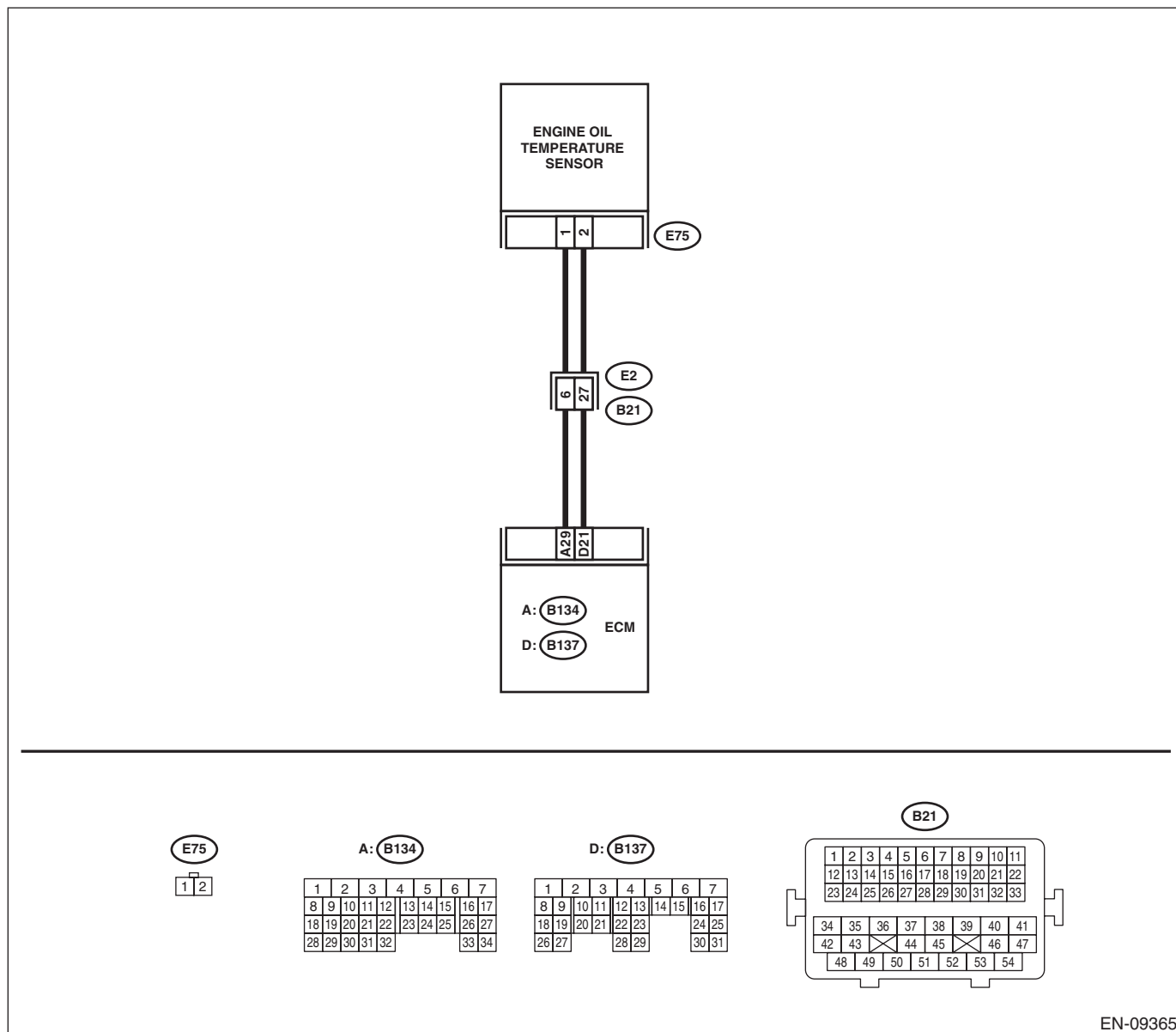

EN-09365

# Diagnostic Procedure with Diagnostic Trouble Code (DTC)

## ENGINE (DIAGNOSTICS)

Step	Check	Yes	No
<p><b>1</b></p> <p><b>CHECK CURRENT DATA.</b></p> <p>1) Start the engine.</p> <p>2) Read the value of «Oil Temperature» using Subaru Select Monitor.</p> <p>NOTE: For detailed operation procedures, refer to “READ CURRENT DATA FOR ENGINE”. &lt;Ref. to EN(H6DO)(diag)-37, Subaru Select Monitor.&gt;</p>	<p>Is the value of «Oil Temperature» 215°C (419°F) or more?</p>	<p>Go to step 2.</p>	<p>Even if DTC is detected, the circuit has returned to a normal condition at this time. Reproduce the failure, and then perform the diagnosis again.</p> <p>NOTE: In this case, temporary poor contact of connector, temporary open or short circuit of harness may be the cause.</p>
<p><b>2</b></p> <p><b>CHECK HARNESS BETWEEN ECM AND ENGINE OIL TEMPERATURE SENSOR CONNECTOR.</b></p> <p>1) Turn the ignition switch to OFF.</p> <p>2) Disconnect the connectors from the ECM and engine oil temperature sensor.</p> <p>3) Measure the resistance between ECM and chassis ground.</p> <p><b>Connector &amp; terminal</b> <b>(B137) No. 21 — Chassis ground:</b></p>	<p>Is the resistance 1 MΩ or more?</p>	<p>Replace the engine oil temperature sensor. &lt;Ref. to FU(H6DO)-47, Oil Temperature Sensor.&gt;</p>	<p>Repair the short circuit to ground in the harness between the ECM and engine oil temperature sensor connector.</p>

# Diagnostic Procedure with Diagnostic Trouble Code (DTC)

ENGINE (DIAGNOSTICS)

## BS:DTC P0198 ENGINE OIL TEMPERATURE SENSOR HIGH

### DTC DETECTING CONDITION:

- Immediately at fault recognition
- GENERAL DESCRIPTION <Ref. to GD(H6DO)-101, DTC P0198 ENGINE OIL TEMPERATURE SENSOR HIGH, Diagnostic Trouble Code (DTC) Detecting Criteria.>

### TROUBLE SYMPTOM:

- Hard to start
- Improper idling
- Poor driving performance

### CAUTION:

After servicing or replacing faulty parts, perform Clear Memory Mode <Ref. to EN(H6DO)(diag)-62, OPERATION, Clear Memory Mode.>, and Inspection Mode <Ref. to EN(H6DO)(diag)-47, PROCEDURE, Inspection Mode.>.

### WIRING DIAGRAM:

Engine electrical system <Ref. to WI-32, Engine Electrical System.>

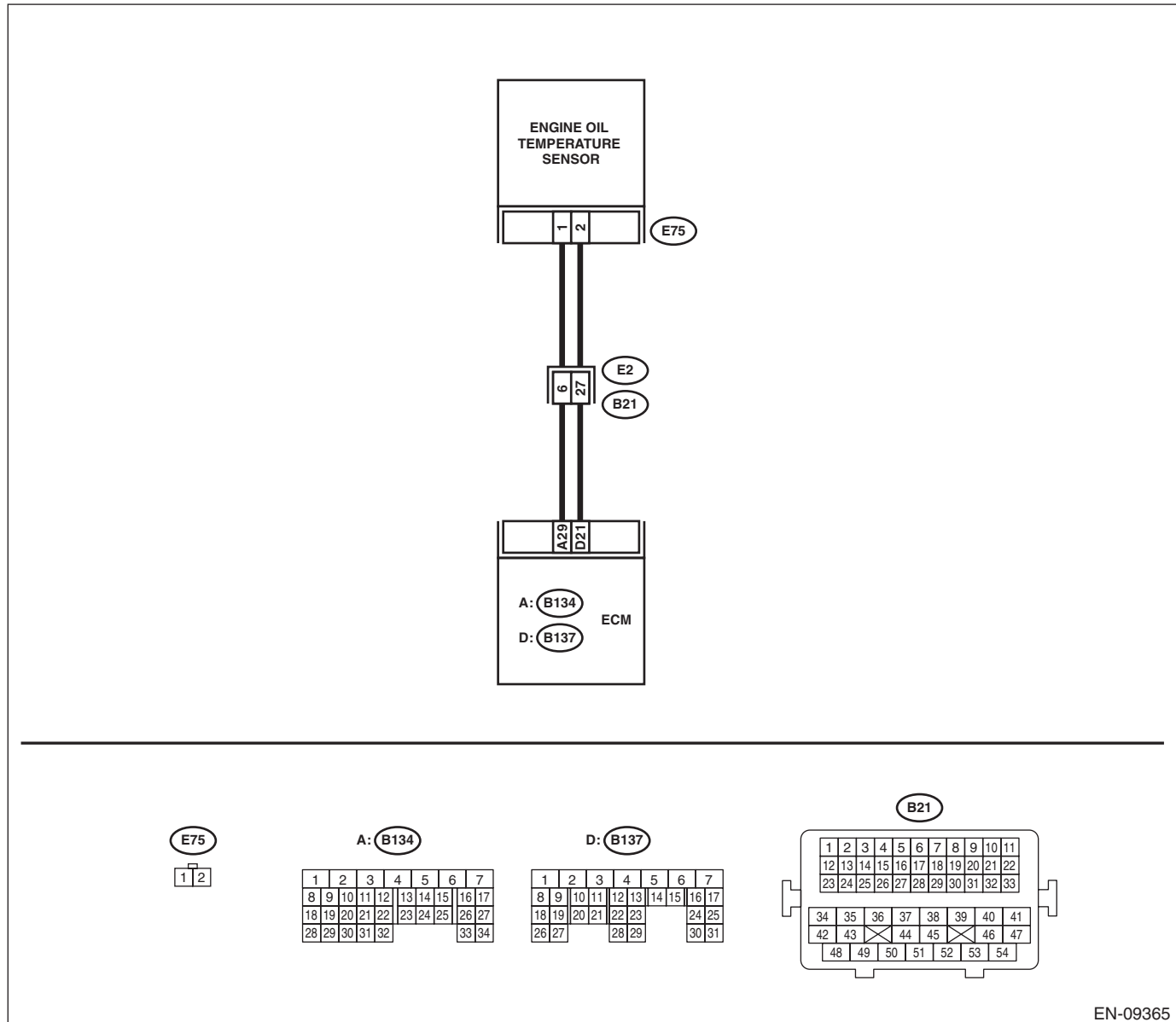

EN-09365

# Diagnostic Procedure with Diagnostic Trouble Code (DTC)

## ENGINE (DIAGNOSTICS)

Step	Check	Yes	No
<b>1 CHECK CURRENT DATA.</b> 1) Start the engine. 2) Read the value of «Oil Temperature» using Subaru Select Monitor.  NOTE: For detailed operation procedures, refer to “READ CURRENT DATA FOR ENGINE”. <Ref. to EN(H6DO)(diag)-37, Subaru Select Monitor.>	Is the value of «Oil Temperature» less than $-40^{\circ}\text{C}$ ( $-40^{\circ}\text{F}$ )?	Go to step 2.	Even if DTC is detected, the circuit has returned to a normal condition at this time. Reproduce the failure, and then perform the diagnosis again.  NOTE: In this case, temporary poor contact of connector, temporary open or short circuit of harness may be the cause.
<b>2 CHECK FOR POOR CONTACT.</b> Check for poor contact between the ECM and engine oil temperature sensor connectors.	Is there poor contact of the ECM or engine oil temperature sensor connectors?	Repair the poor contact of ECM or engine oil temperature sensor connector.	Go to step 3.
<b>3 CHECK HARNESS BETWEEN ECM AND ENGINE OIL TEMPERATURE SENSOR CONNECTOR.</b> 1) Turn the ignition switch to OFF. 2) Disconnect the connectors from the ECM and engine oil temperature sensor. 3) Measure the resistance of the harness between the ECM and engine oil temperature sensor connector.  <b>Connector &amp; terminal</b> <b>(B134) No. 29 — (E75) No. 1:</b> <b>(B137) No. 21 — (E75) No. 2:</b>	Is the resistance less than $1\ \Omega$ ?	Go to step 4.	Repair the harness and connector.  NOTE: In this case, repair the following item: <ul style="list-style-type: none"> <li>• Open circuit in harness between ECM and engine oil temperature sensor connector</li> <li>• Poor contact of coupling connector</li> </ul>
<b>4 CHECK HARNESS BETWEEN ECM AND ENGINE OIL TEMPERATURE SENSOR CONNECTOR.</b> 1) Connect all connectors. 2) Turn the ignition switch to ON. 3) Measure the voltage between ECM and chassis ground.  <b>Connector &amp; terminal</b> <b>(B137) No. 21 (+) — Chassis ground (-):</b>	Is the voltage 5 V or more?	Repair the short circuit to power in harness between ECM and engine oil temperature sensor connector.	Replace the engine oil temperature sensor. <Ref. to FU(H6DO)-47, Oil Temperature Sensor.>

# Diagnostic Procedure with Diagnostic Trouble Code (DTC)

ENGINE (DIAGNOSTICS)

## BT:DTC P0201 INJECTOR #1

### DTC DETECTING CONDITION:

- Immediately at fault recognition
- GENERAL DESCRIPTION <Ref. to GD(H6DO)-102, DTC P0201 INJECTOR #1, Diagnostic Trouble Code (DTC) Detecting Criteria.>

### TROUBLE SYMPTOM:

- Improper idling
- Poor driving performance

### CAUTION:

After servicing or replacing faulty parts, perform Clear Memory Mode <Ref. to EN(H6DO)(diag)-62, OPERATION, Clear Memory Mode.>, and Inspection Mode <Ref. to EN(H6DO)(diag)-47, PROCEDURE, Inspection Mode.>.

### WIRING DIAGRAM:

Engine electrical system <Ref. to WI-32, Engine Electrical System.>

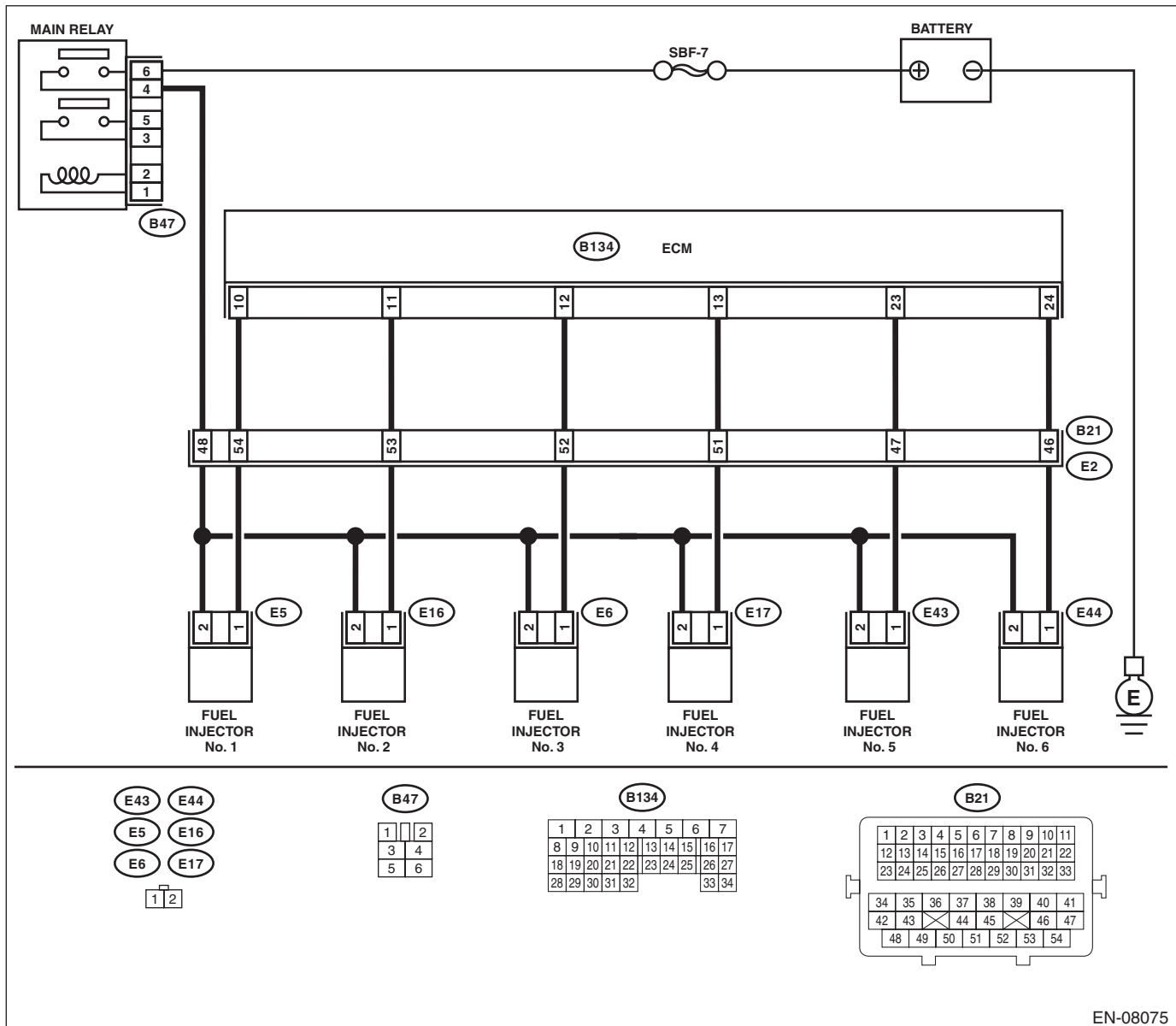

EN-08075

# Diagnostic Procedure with Diagnostic Trouble Code (DTC)

## ENGINE (DIAGNOSTICS)

Step	Check	Yes	No
<p><b>1 CHECK POWER SUPPLY TO FUEL INJECTOR.</b></p> <p>1) Turn the ignition switch to OFF.                      2) Disconnect the connector from fuel injector.                      3) Turn the ignition switch to ON.                      4) Measure the voltage between fuel injector connector and the engine ground.</p> <p><b>Connector &amp; terminal</b>  <b>DTC P0201; (E5) No. 2 (+) — Engine ground (-):</b>  <b>DTC P0202; (E16) No. 2 (+) — Engine ground (-):</b>  <b>DTC P0203; (E6) No. 2 (+) — Engine ground (-):</b>  <b>DTC P0204; (E17) No. 2 (+) — Engine ground (-):</b>  <b>DTC P0205; (E43) No. 2 (+) — Engine ground (-):</b>  <b>DTC P0206; (E44) No. 2 (+) — Engine ground (-):</b></p>	Is the voltage 10 V or more?	Go to step 2.	Repair the harness and connector.  NOTE: In this case, repair the following item: • Open circuit in harness between main relay and fuel injector connector • Poor contact of main relay connector • Poor contact of coupling connector
<p><b>2 CHECK HARNESS BETWEEN ECM AND FUEL INJECTOR CONNECTOR.</b></p> <p>1) Turn the ignition switch to OFF.                      2) Disconnect the connector from ECM.                      3) Measure the resistance between fuel injector connector and engine ground.</p> <p><b>Connector &amp; terminal</b>  <b>DTC P0201; (E5) No. 1 — Engine ground:</b>  <b>DTC P0202; (E16) No. 1 — Engine ground:</b>  <b>DTC P0203; (E6) No. 1 — Engine ground:</b>  <b>DTC P0204; (E17) No. 1 — Engine ground:</b>  <b>DTC P0205; (E43) No. 1 — Engine ground:</b>  <b>DTC P0206; (E44) No. 1 — Engine ground:</b></p>	Is the resistance 1 M $\Omega$ or more?	Go to step 3.	Repair the short circuit to ground in harness between ECM connector and fuel injector connector.
<p><b>3 CHECK HARNESS BETWEEN ECM AND FUEL INJECTOR CONNECTOR.</b></p> <p>Measure the resistance of harness between ECM connector and fuel injector connector.</p> <p><b>Connector &amp; terminal</b>  <b>DTC P0201; (B134) No. 10 — (E5) No. 1:</b>  <b>DTC P0202; (B134) No. 11 — (E16) No. 1:</b>  <b>DTC P0203; (B134) No. 12 — (E6) No. 1:</b>  <b>DTC P0204; (B134) No. 13 — (E17) No. 1:</b>  <b>DTC P0205; (B134) No. 23 — (E43) No. 1:</b>  <b>DTC P0206; (B134) No. 24 — (E44) No. 1:</b></p>	Is the resistance less than 1 $\Omega$ ?	Go to step 4.	Repair the harness and connector.  NOTE: In this case, repair the following item: • Open circuit in harness between ECM connector and fuel injector connector • Poor contact of coupling connector
<p><b>4 CHECK FUEL INJECTOR.</b></p> <p>Measure the resistance between fuel injector terminals on the corresponding cylinder.</p> <p><b>Terminals</b>  <b>No. 1 — No. 2:</b></p>	Is the resistance 5 — 20 $\Omega$ ?	Go to step 5.	Replace the fuel injector. <Ref. to FU(H6DO)-42, Fuel Injector.>
<p><b>5 CHECK FOR POOR CONTACT.</b></p> <p>Check for poor contact of ECM connector.</p>	Is there poor contact of ECM connector?	Repair the poor contact of ECM connector.	Go to step 6.



# Diagnostic Procedure with Diagnostic Trouble Code (DTC)

ENGINE (DIAGNOSTICS)

Step	Check	Yes	No
<b>6</b> <b>CHECK FUEL INJECTOR OPERATION.</b> 1) Connect all connectors. 2) Start the engine. 3) Check if the corresponding fuel injector emits operating sound.  NOTE: Use a sound scope to check the operating sound.	Does the fuel injector emit operating sound?	Even if DTC is detected, the circuit has returned to a normal condition at this time. Reproduce the failure, and then perform the diagnosis again.  NOTE: In this case, temporary poor contact of connector, temporary open or short circuit of harness may be the cause.	Repair the poor contact of fuel injector connector.

## **BU:DTC P0202 INJECTOR #2**

NOTE:

For the diagnostic procedure, refer to DTC P0201. <Ref. to EN(H6DO)(diag)-193, DTC P0201 INJECTOR #1, Diagnostic Procedure with Diagnostic Trouble Code (DTC).>

## **BV:DTC P0203 INJECTOR #3**

NOTE:

For the diagnostic procedure, refer to DTC P0201. <Ref. to EN(H6DO)(diag)-193, DTC P0201 INJECTOR #1, Diagnostic Procedure with Diagnostic Trouble Code (DTC).>

## **BW:DTC P0204 INJECTOR #4**

NOTE:

For the diagnostic procedure, refer to DTC P0201. <Ref. to EN(H6DO)(diag)-193, DTC P0201 INJECTOR #1, Diagnostic Procedure with Diagnostic Trouble Code (DTC).>

## **BX:DTC P0205 INJECTOR #5**

NOTE:

For the diagnostic procedure, refer to DTC P0201. <Ref. to EN(H6DO)(diag)-193, DTC P0201 INJECTOR #1, Diagnostic Procedure with Diagnostic Trouble Code (DTC).>

## **BY:DTC P0206 INJECTOR #6**

NOTE:

For the diagnostic procedure, refer to DTC P0201. <Ref. to EN(H6DO)(diag)-193, DTC P0201 INJECTOR #1, Diagnostic Procedure with Diagnostic Trouble Code (DTC).>

# Diagnostic Procedure with Diagnostic Trouble Code (DTC)

ENGINE (DIAGNOSTICS)

## BZ:DTC P0222 THROTTLE/PEDAL POSITION SENSOR/SWITCH "B" CIRCUIT LOW

### DTC DETECTING CONDITION:

- Immediately at fault recognition
- GENERAL DESCRIPTION <Ref. to GD(H6DO)-104, DTC P0222 THROTTLE/PEDAL POSITION SENSOR/SWITCH "B" CIRCUIT LOW, Diagnostic Trouble Code (DTC) Detecting Criteria.>

### TROUBLE SYMPTOM:

- Improper idling
- Poor driving performance
- Engine stalls.

### CAUTION:

After servicing or replacing faulty parts, perform Clear Memory Mode <Ref. to EN(H6DO)(diag)-62, OPERATION, Clear Memory Mode.>, and Inspection Mode <Ref. to EN(H6DO)(diag)-47, PROCEDURE, Inspection Mode.>.

### WIRING DIAGRAM:

Engine electrical system <Ref. to WI-32, Engine Electrical System.>

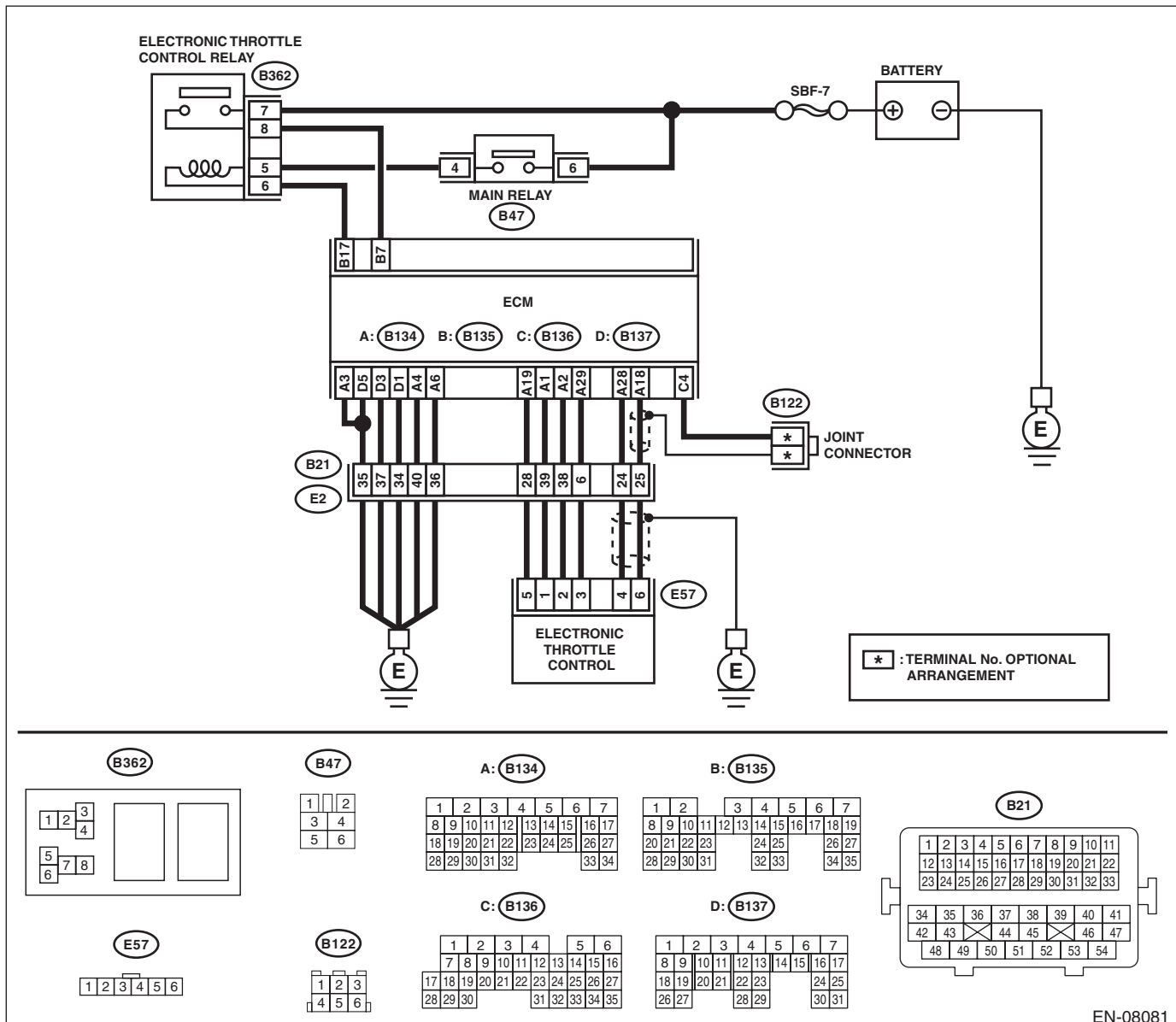

EN-08081

# Diagnostic Procedure with Diagnostic Trouble Code (DTC)

ENGINE (DIAGNOSTICS)

	Step	Check	Yes	No
1	<p><b>CHECK HARNESS BETWEEN ECM AND ELECTRONIC THROTTLE CONTROL.</b></p> <p>1) Turn the ignition switch to OFF.</p> <p>2) Disconnect the connectors from ECM and electronic throttle control.</p> <p>3) Measure the resistance between ECM and chassis ground.</p> <p><b>Connector &amp; terminal</b>  <b>(B134) No. 19 — Chassis ground:</b>  <b>(B134) No. 28 — Chassis ground:</b></p>	Is the resistance 1 MΩ or more?	Go to step 2.	Repair the short circuit to ground in harness between ECM and electronic throttle control connector.
2	<p><b>CHECK SHORT CIRCUIT INSIDE THE ECM.</b></p> <p>1) Connect the connector to ECM.</p> <p>2) Measure the resistance between electronic throttle control connector and engine ground.</p> <p><b>Connector &amp; terminal</b>  <b>(E57) No. 4 — Engine ground:</b></p>	Is the resistance 1 MΩ or more?	Replace the electronic throttle control. <Ref. to FU(H6DO)-19, Throttle Body.>	Repair the short circuit to ground in harness between ECM and electronic throttle control connector. Replace the ECM if defective. <Ref. to FU(H6DO)-51, Engine Control Module (ECM).>

# Diagnostic Procedure with Diagnostic Trouble Code (DTC)

ENGINE (DIAGNOSTICS)

## CA:DTC P0223 THROTTLE/PEDAL POSITION SENSOR/SWITCH "B" CIRCUIT HIGH

### DTC DETECTING CONDITION:

- Immediately at fault recognition
- GENERAL DESCRIPTION <Ref. to GD(H6DO)-106, DTC P0223 THROTTLE/PEDAL POSITION SENSOR/SWITCH "B" CIRCUIT HIGH, Diagnostic Trouble Code (DTC) Detecting Criteria.>

### TROUBLE SYMPTOM:

- Improper idling
- Poor driving performance
- Engine stalls.

### CAUTION:

After servicing or replacing faulty parts, perform Clear Memory Mode <Ref. to EN(H6DO)(diag)-62, OPERATION, Clear Memory Mode.>, and Inspection Mode <Ref. to EN(H6DO)(diag)-47, PROCEDURE, Inspection Mode.>.

### WIRING DIAGRAM:

Engine electrical system <Ref. to WI-32, Engine Electrical System.>

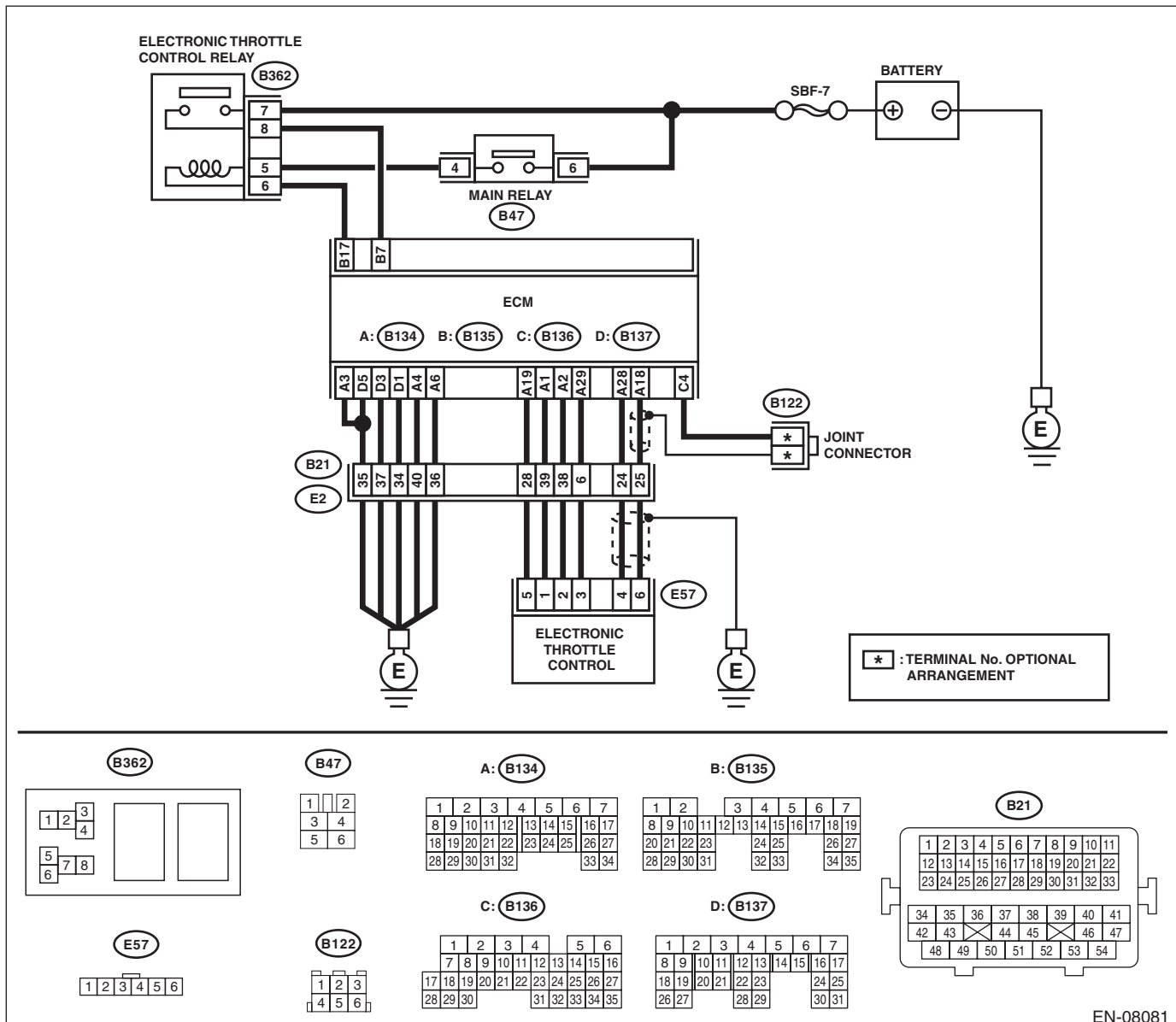

EN-08081

# Diagnostic Procedure with Diagnostic Trouble Code (DTC)

ENGINE (DIAGNOSTICS)

Step	Check	Yes	No
<b>1</b> <b>CHECK HARNESS BETWEEN ECM AND ELECTRONIC THROTTLE CONTROL.</b> 1) Turn the ignition switch to OFF. 2) Disconnect the connectors from ECM and electronic throttle control. 3) Measure the resistance of harness between ECM and electronic throttle control connector. <b>Connector &amp; terminal</b> <b>(B134) No. 28 — (E57) No. 4:</b> <b>(B134) No. 29 — (E57) No. 3:</b>	Is the resistance less than 1 Ω?	Go to step 2.	Repair the harness and connector. NOTE: In this case, repair the following item: • Open circuit in harness between ECM and electronic throttle control connector • Poor contact of coupling connector
<b>2</b> <b>CHECK HARNESS BETWEEN ECM AND ELECTRONIC THROTTLE CONTROL.</b> 1) Connect the connector to ECM. 2) Measure the resistance between electronic throttle control connector and engine ground. <b>Connector &amp; terminal</b> <b>(E57) No. 3 — Engine ground:</b>	Is the resistance less than 5 Ω?	Go to step 3.	Repair the harness and connector. NOTE: In this case, repair the following item: • Open circuit of harness between ECM and engine ground • Poor contact of ECM connector • Poor contact of coupling connector
<b>3</b> <b>CHECK HARNESS BETWEEN ECM AND ELECTRONIC THROTTLE CONTROL.</b> 1) Turn the ignition switch to ON. 2) Measure the voltage between electronic throttle control connector and engine ground. <b>Connector &amp; terminal</b> <b>(E57) No. 4 (+) — Engine ground (-):</b>	Is the voltage 5 V or more?	Repair the short circuit to power in harness between ECM and electronic throttle control connector.	Go to step 4.
<b>4</b> <b>CHECK HARNESS BETWEEN ECM AND ELECTRONIC THROTTLE CONTROL.</b> 1) Turn the ignition switch to OFF. 2) Disconnect the connector from ECM. 3) Measure the resistance between ECM connectors. <b>Connector &amp; terminal</b> <b>(B134) No. 19 — (B134) No. 28:</b>	Is the resistance 1 MΩ or more?	Repair the poor contact of electronic throttle control connector. Replace the electronic throttle control if defective. <Ref. to FU(H6DO)-19, Throttle Body.>	Repair the short circuit to power in harness between ECM and electronic throttle control connector.

# Diagnostic Procedure with Diagnostic Trouble Code (DTC)

ENGINE (DIAGNOSTICS)

## CB:DTC P0230 FUEL PUMP PRIMARY CIRCUIT

### DTC DETECTING CONDITION:

- Detected when two consecutive driving cycles with fault occur.
- GENERAL DESCRIPTION <Ref. to GD(H6DO)-108, DTC P0230 FUEL PUMP PRIMARY CIRCUIT, Diagnostic Trouble Code (DTC) Detecting Criteria.>

### CAUTION:

After servicing or replacing faulty parts, perform Clear Memory Mode <Ref. to EN(H6DO)(diag)-62, OPERATION, Clear Memory Mode.>, and Inspection Mode <Ref. to EN(H6DO)(diag)-47, PROCEDURE, Inspection Mode.>.

### WIRING DIAGRAM:

Engine electrical system <Ref. to WI-32, Engine Electrical System.>

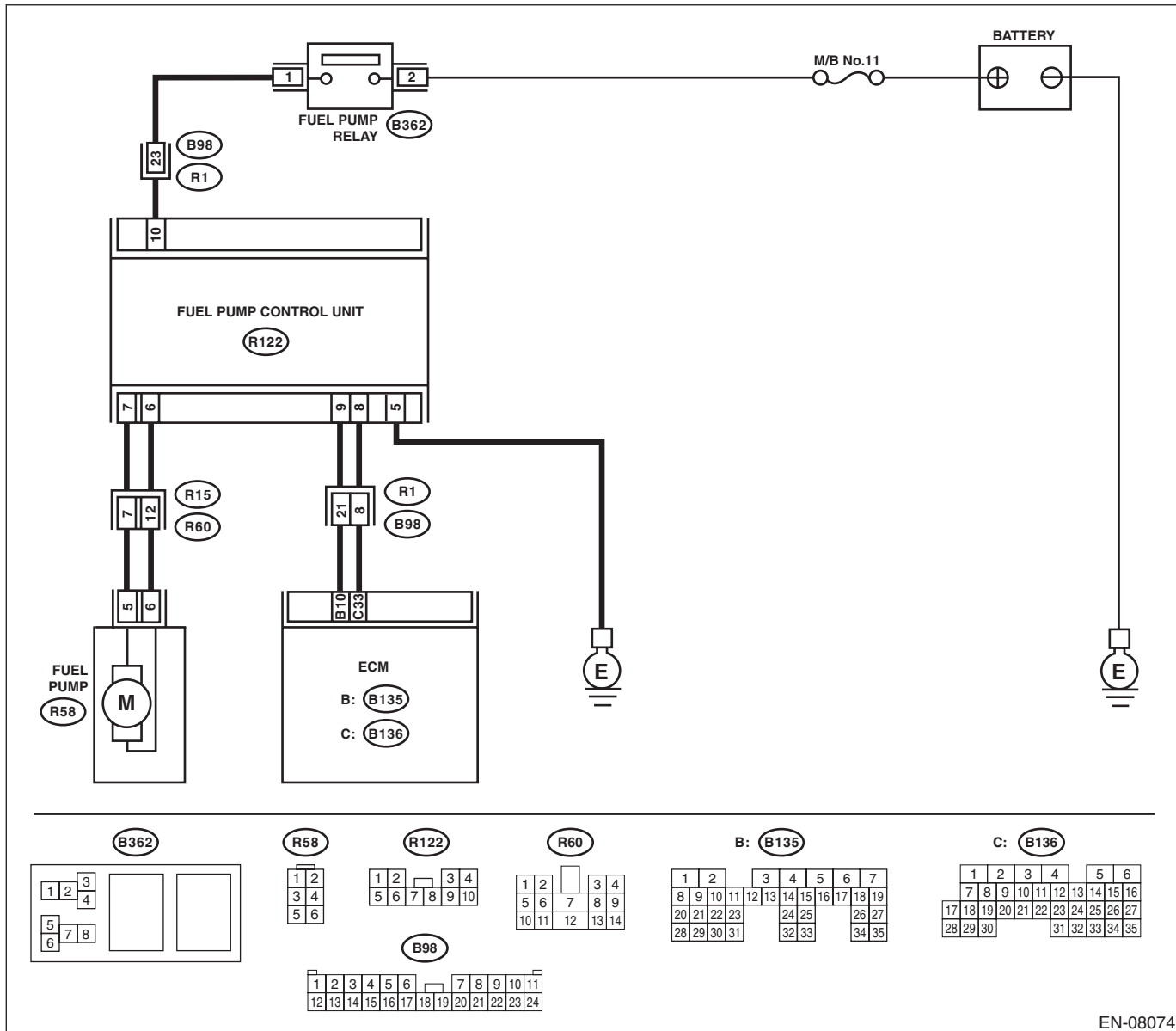

EN-08074

# Diagnostic Procedure with Diagnostic Trouble Code (DTC)

ENGINE (DIAGNOSTICS)

Step	Check	Yes	No
<p><b>1</b>      <b>CHECK POWER SUPPLY CIRCUIT TO FUEL PUMP CONTROL UNIT.</b>            1) Turn the ignition switch to OFF.            2) Disconnect the connector from fuel pump control unit.            3) Turn the ignition switch to ON.            4) Measure the voltage between fuel pump control unit and chassis ground.  <b>Connector &amp; terminal</b>  <b>(R122) No. 10 (+) — Chassis ground (-):</b></p>	<p>Is the voltage 10 V or more?</p>	<p>Go to step 2.</p>	<p>Repair the power supply circuit.  <b>NOTE:</b>            In this case, repair the following item:            • Open circuit or short circuit to ground in harness between fuel pump relay connector and fuel pump control unit connector            • Poor contact of fuel pump relay connector            • Poor contact of coupling connector</p>
<p><b>2</b>      <b>CHECK GROUND CIRCUIT OF FUEL PUMP CONTROL UNIT.</b>            1) Turn the ignition switch to OFF.            2) Measure the resistance of harness between fuel pump control unit and chassis ground.  <b>Connector &amp; terminal</b>  <b>(R122) No. 5 — Chassis ground:</b></p>	<p>Is the resistance less than 5 Ω?</p>	<p>Go to step 3.</p>	<p>Repair the open circuit in harness between fuel pump control unit connector and chassis ground.</p>
<p><b>3</b>      <b>CHECK HARNESS BETWEEN FUEL PUMP CONTROL UNIT AND FUEL PUMP CONNECTOR.</b>            1) Disconnect the connector from fuel pump.            2) Measure the resistance of harness between fuel pump control unit and fuel pump connector.  <b>Connector &amp; terminal</b>  <b>(R122) No. 7 — (R58) No. 5:</b>  <b>(R122) No. 6 — (R58) No. 6:</b></p>	<p>Is the resistance less than 1 Ω?</p>	<p>Go to step 4.</p>	<p>Repair the harness and connector.  <b>NOTE:</b>            In this case, repair the following item:            • Open circuit in harness between fuel pump control unit connector and fuel pump connector            • Poor contact of coupling connector</p>
<p><b>4</b>      <b>CHECK HARNESS BETWEEN FUEL PUMP CONTROL UNIT AND FUEL PUMP CONNECTOR.</b>            Measure the resistance between fuel pump control unit and chassis ground.  <b>Connector &amp; terminal</b>  <b>(R122) No. 7 — Chassis ground:</b>  <b>(R122) No. 6 — Chassis ground:</b></p>	<p>Is the resistance 1 MΩ or more?</p>	<p>Go to step 5.</p>	<p>Repair the short circuit to ground in harness between fuel pump control unit connector and fuel pump connector.</p>
<p><b>5</b>      <b>CHECK HARNESS BETWEEN ECM AND FUEL PUMP CONTROL UNIT.</b>            1) Disconnect the connector from ECM.            2) Measure the resistance of the harness between the ECM and fuel pump control unit.  <b>Connector &amp; terminal</b>  <b>(B136) No. 33 — (R122) No. 8:</b>  <b>(B135) No. 10 — (R122) No. 9:</b></p>	<p>Is the resistance less than 1 Ω?</p>	<p>Go to step 6.</p>	<p>Repair the harness and connector.  <b>NOTE:</b>            In this case, repair the following item:            • Open circuit in harness between ECM and fuel pump control unit connector            • Poor contact of coupling connector</p>

## Diagnostic Procedure with Diagnostic Trouble Code (DTC)

### ENGINE (DIAGNOSTICS)

Step	Check	Yes	No
<b>6</b> <b>CHECK HARNESS BETWEEN ECM AND FUEL PUMP CONTROL UNIT.</b> Measure the resistance between fuel pump control unit and chassis ground. <i><b>Connector &amp; terminal</b></i> <i><b>(R122) No. 8 — Chassis ground:</b></i> <i><b>(R122) No. 9 — Chassis ground:</b></i>	Is the resistance 1 MΩ or more?	Go to step 7.	Repair the short circuit to ground in harness between ECM and fuel pump control unit connector.
<b>7</b> <b>CHECK FOR POOR CONTACT.</b> Check for poor contact of ECM and fuel pump control unit connector.	Is there poor contact of ECM or fuel pump control unit connector?	Repair the poor contact of ECM or fuel pump control unit connector.	Go to step 8.
<b>8</b> <b>CHECK EXPERIENCE OF RUNNING OUT OF FUEL.</b>	Has the vehicle experienced running out of fuel?	Finish the diagnosis. NOTE: DTC may be recorded as a result of fuel pump idling while running out of fuel.	Replace the fuel pump control unit. <Ref. to FU(H6DO)-57, Fuel Pump Control Unit.>



# Diagnostic Procedure with Diagnostic Trouble Code (DTC)

ENGINE (DIAGNOSTICS)

## CC:DTC P0300 RANDOM/MULTIPLE CYLINDER MISFIRE DETECTED

### DTC DETECTING CONDITION:

- Detected when two consecutive driving cycles with fault occur.
- Immediately at fault recognition (A misfire which could damage catalyst occurs.)
- GENERAL DESCRIPTION <Ref. to GD(H6DO)-109, DTC P0300 RANDOM/MULTIPLE CYLINDER MISFIRE DETECTED, Diagnostic Trouble Code (DTC) Detecting Criteria.>

### TROUBLE SYMPTOM:

- Engine stalls.
- Improper idling
- Rough driving

### CAUTION:

After servicing or replacing faulty parts, perform Clear Memory Mode <Ref. to EN(H6DO)(diag)-62, OPERATION, Clear Memory Mode.>, and Inspection Mode <Ref. to EN(H6DO)(diag)-47, PROCEDURE, Inspection Mode.>.

### WIRING DIAGRAM:

Engine electrical system <Ref. to WI-32, Engine Electrical System.>

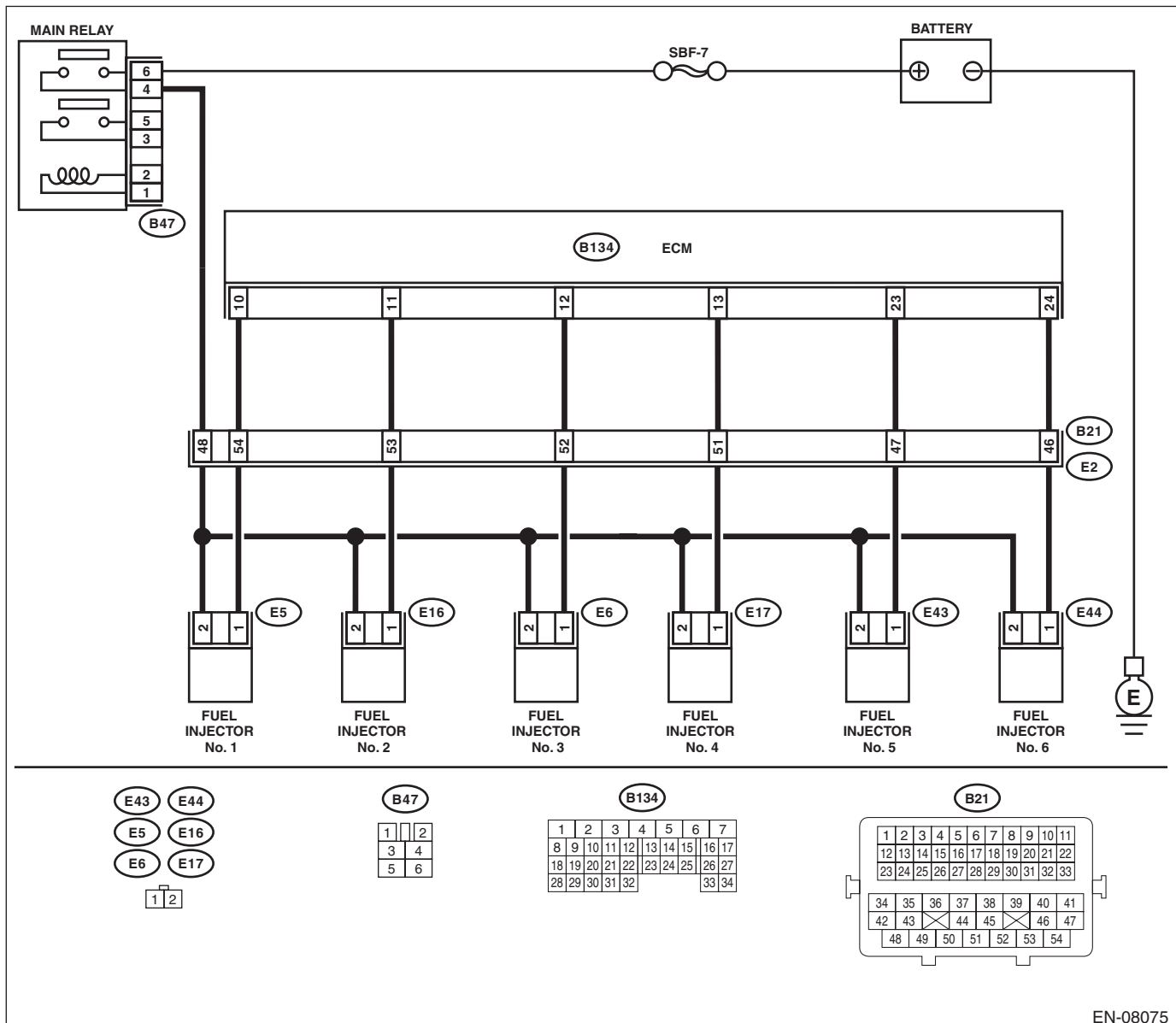

EN-08075

# Diagnostic Procedure with Diagnostic Trouble Code (DTC)

## ENGINE (DIAGNOSTICS)

Step	Check	Yes	No
<p><b>1 CHECK OUTPUT SIGNAL OF ECM.</b></p> <p>1) Turn the ignition switch to ON. 2) Measure the voltage between ECM and chassis ground on all cylinders.</p> <p><b>Connector &amp; terminal</b></p> <p><b>#1 (B134) No. 10 (+) — Chassis ground (-):</b>  <b>#2 (B134) No. 11 (+) — Chassis ground (-):</b>  <b>#3 (B134) No. 12 (+) — Chassis ground (-):</b>  <b>#4 (B134) No. 13 (+) — Chassis ground (-):</b>  <b>#5 (B134) No. 23 (+) — Chassis ground (-):</b>  <b>#6 (B134) No. 24 (+) — Chassis ground (-):</b></p>	Is the voltage 10 V or more?	Go to step 6.	Go to step 2.
<p><b>2 CHECK HARNESS BETWEEN ECM AND FUEL INJECTOR.</b></p> <p>1) Turn the ignition switch to OFF. 2) Disconnect the connector from all fuel injectors. 3) Measure the resistance between all fuel injector connectors and engine ground.</p> <p><b>Connector &amp; terminal</b></p> <p><b>#1 (E5) No. 1 — Engine ground:</b>  <b>#2 (E16) No. 1 — Engine ground:</b>  <b>#3 (E6) No. 1 — Engine ground:</b>  <b>#4 (E17) No. 1 — Engine ground:</b>  <b>#5 (E43) No. 1 — Engine ground:</b>  <b>#6 (E44) No. 1 — Engine ground:</b></p>	Is the resistance 1 M $\Omega$ or more?	Go to step 3.	Repair the short circuit to ground in harness between ECM and fuel injector connector.
<p><b>3 CHECK HARNESS BETWEEN ECM AND FUEL INJECTOR.</b></p> <p>Measure the resistance of harness between ECM and fuel injector connector on all cylinders.</p> <p><b>Connector &amp; terminal</b></p> <p><b>#1 (B134) No. 10 — (E5) No. 1:</b>  <b>#2 (B134) No. 11 — (E16) No. 1:</b>  <b>#3 (B134) No. 12 — (E6) No. 1:</b>  <b>#4 (B134) No. 13 — (E17) No. 1:</b>  <b>#5 (B134) No. 23 — (E43) No. 1:</b>  <b>#6 (B134) No. 24 — (E44) No. 1:</b></p>	Is the resistance less than 1 $\Omega$ ?	Go to step 4.	Repair the harness and connector. NOTE: In this case, repair the following item: <ul style="list-style-type: none"> <li>• Open circuit in harness between ECM and fuel injector connector</li> <li>• Poor contact of coupling connector</li> </ul>
<p><b>4 CHECK FUEL INJECTOR.</b></p> <p>Measure the resistance between all fuel injector terminals.</p> <p><b>Terminals</b></p> <p><b>No. 1 — No. 2:</b></p>	Is the resistance 5 — 20 $\Omega$ ?	Go to step 5.	Replace the faulty fuel injector. <Ref. to FU(H6DO)-42, Fuel Injector.>
<p><b>5 CHECK POWER SUPPLY LINE.</b></p> <p>1) Turn the ignition switch to ON. 2) Measure the voltage between all fuel injector connectors and the engine ground.</p> <p><b>Connector &amp; terminal</b></p> <p><b>#1 (E5) No. 2 (+) — Engine ground (-):</b>  <b>#2 (E16) No. 2 (+) — Engine ground (-):</b>  <b>#3 (E6) No. 2 (+) — Engine ground (-):</b>  <b>#4 (E17) No. 2 (+) — Engine ground (-):</b>  <b>#5 (E43) No. 2 (+) — Engine ground (-):</b>  <b>#6 (E44) No. 2 (+) — Engine ground (-):</b></p>	Is the voltage 10 V or more?	Repair the poor contact of all connectors in fuel injector circuit.	Repair the harness and connector. NOTE: In this case, repair the following item: <ul style="list-style-type: none"> <li>• Open circuit in harness between the main relay and fuel injector connector on faulty cylinders</li> <li>• Poor contact of coupling connector</li> <li>• Poor contact of main relay connector</li> </ul>

# Diagnostic Procedure with Diagnostic Trouble Code (DTC)

ENGINE (DIAGNOSTICS)

Step	Check	Yes	No
<b>6 CHECK HARNESS BETWEEN ECM AND FUEL INJECTOR.</b> 1) Turn the ignition switch to OFF. 2) Disconnect the connector from all fuel injectors. 3) Turn the ignition switch to ON. 4) Measure the voltage between ECM and chassis ground on all cylinders. <b>Connector &amp; terminal</b> <b>#1 (B134) No. 10 (+) — Chassis ground (-):</b> <b>#2 (B134) No. 11 (+) — Chassis ground (-):</b> <b>#3 (B134) No. 12 (+) — Chassis ground (-):</b> <b>#4 (B134) No. 13 (+) — Chassis ground (-):</b> <b>#5 (B134) No. 23 (+) — Chassis ground (-):</b> <b>#6 (B134) No. 24 (+) — Chassis ground (-):</b>	Is the voltage 10 V or more?	Repair the short circuit to power in harness between ECM and fuel injector connector.	Go to step 7.
<b>7 CHECK FUEL INJECTOR.</b> 1) Turn the ignition switch to OFF. 2) Measure the resistance between all fuel injector terminals. <b>Terminals</b> <b>No. 1 — No. 2:</b>	Is the resistance 5 — 20 Ω?	Go to step 8.	Replace the faulty fuel injector. <Ref. to FU(H6DO)-42, Fuel Injector.>
<b>8 CHECK INSTALLATION OF CAMSHAFT POSITION SENSOR/CRANKSHAFT POSITION SENSOR.</b>	Is the camshaft position sensor or crankshaft position sensor loosely installed?	Tighten the camshaft position sensor or crankshaft position sensor. <Ref. to FU(H6DO)-35, INSTALLATION, Camshaft Position Sensor.> <Ref. to FU(H6DO)-32, INSTALLATION, Crankshaft Position Sensor.>	Go to step 9.
<b>9 CHECK CRANK PLATE.</b>	Is the crank sprocket rusted or the teeth of crank plate broken?	Replace the crank plate. <Ref. to ME(H6DO)-97, Cylinder Block.>	Go to step 10.
<b>10 CHECK INSTALLATION CONDITION OF TIMING CHAIN.</b> Turn the crankshaft using ST, and align the alignment mark on crank sprocket with alignment mark on cylinder block. ST 18252AA000      CRANKSHAFT SOCKET	Is the timing chain dislocated from its proper position?	Correct the installation condition of timing chain. <Ref. to ME(H6DO)-54, Timing Chain Assembly.>	Go to step 11.
<b>11 CHECK FUEL LEVEL.</b>	Is the fuel meter indication lower than the “Lower” level?	Refill the fuel so that the fuel meter indication is higher than the “Lower” level, and proceed to the next step. Go to step 13.	Go to step 12.
<b>12 CHECK STATUS OF MALFUNCTION INDICATOR LIGHT.</b> 1) Clear the memory using the Subaru Select Monitor or general scan tool. <Ref. to EN(H6DO)(diag)-62, Clear Memory Mode.> 2) Start the engine, and drive the vehicle 10 minutes or more.	Does the malfunction indicator light illuminate or blink?	Go to step 14.	Go to step 13.

## Diagnostic Procedure with Diagnostic Trouble Code (DTC)

ENGINE (DIAGNOSTICS)

Step	Check	Yes	No
<b>13</b>	<b>CHECK CAUSE OF MISFIRE.</b>	Was the cause of misfire identified when the engine is running?	Finish diagnostics operation, if the engine has no abnormality.  Repair the poor contact of connector. NOTE: In this case, repair the following item: <ul style="list-style-type: none"> <li>• Poor contact of ignition coil connector</li> <li>• Poor contact of fuel injector connector on faulty cylinders</li> <li>• Poor contact of ECM connector</li> <li>• Poor contact of coupling connector</li> </ul>
<b>14</b>	<b>CHECK AIR INTAKE SYSTEM.</b>	Is there any fault in air intake system?	Repair the air intake system. NOTE: Check the following items. <ul style="list-style-type: none"> <li>• Are there air leaks or air suction caused by loose or dislocated nuts and bolts?</li> <li>• Are there cracks or any disconnection of hoses?</li> </ul>
<b>15</b>	<b>CHECK ALL CYLINDERS.</b>	Is there a fault in any cylinder?	Repair or replace the faulty part of the faulty cylinder. NOTE: Check the following items. <ul style="list-style-type: none"> <li>• Spark plug</li> <li>• Ignition coil</li> <li>• Fuel injector</li> <li>• Compression ratio</li> <li>• Skipping timing chain teeth</li> </ul>

## **CD:DTC P0301 CYLINDER 1 MISFIRE DETECTED**

**NOTE:**

For the diagnostic procedure, refer to DTC P0306. <Ref. to EN(H6DO)(diag)-208, DTC P0306 CYLINDER 6 MISFIRE DETECTED, Diagnostic Procedure with Diagnostic Trouble Code (DTC).>

## **CE:DTC P0302 CYLINDER 2 MISFIRE DETECTED**

**NOTE:**

For the diagnostic procedure, refer to DTC P0306. <Ref. to EN(H6DO)(diag)-208, DTC P0306 CYLINDER 6 MISFIRE DETECTED, Diagnostic Procedure with Diagnostic Trouble Code (DTC).>

## **CF:DTC P0303 CYLINDER 3 MISFIRE DETECTED**

**NOTE:**

For the diagnostic procedure, refer to DTC P0306. <Ref. to EN(H6DO)(diag)-208, DTC P0306 CYLINDER 6 MISFIRE DETECTED, Diagnostic Procedure with Diagnostic Trouble Code (DTC).>

## **CG:DTC P0304 CYLINDER 4 MISFIRE DETECTED**

**NOTE:**

For the diagnostic procedure, refer to DTC P0306. <Ref. to EN(H6DO)(diag)-208, DTC P0306 CYLINDER 6 MISFIRE DETECTED, Diagnostic Procedure with Diagnostic Trouble Code (DTC).>

## **CH:DTC P0305 CYLINDER 5 MISFIRE DETECTED**

**NOTE:**

For the diagnostic procedure, refer to DTC P0306. <Ref. to EN(H6DO)(diag)-208, DTC P0306 CYLINDER 6 MISFIRE DETECTED, Diagnostic Procedure with Diagnostic Trouble Code (DTC).>

# Diagnostic Procedure with Diagnostic Trouble Code (DTC)

ENGINE (DIAGNOSTICS)

## CI: DTC P0306 CYLINDER 6 MISFIRE DETECTED

### DTC DETECTING CONDITION:

- Detected when two consecutive driving cycles with fault occur.
- Immediately at fault recognition (A misfire which could damage catalyst occurs.)
- GENERAL DESCRIPTION <Ref. to GD(H6DO)-117, DTC P0306 CYLINDER 6 MISFIRE DETECTED, Diagnostic Trouble Code (DTC) Detecting Criteria.>

### TROUBLE SYMPTOM:

- Engine stalls.
- Improper idling
- Rough driving

### CAUTION:

After servicing or replacing faulty parts, perform Clear Memory Mode <Ref. to EN(H6DO)(diag)-62, OPERATION, Clear Memory Mode.>, and Inspection Mode <Ref. to EN(H6DO)(diag)-47, PROCEDURE, Inspection Mode.>.

### WIRING DIAGRAM:

Engine electrical system <Ref. to WI-32, Engine Electrical System.>

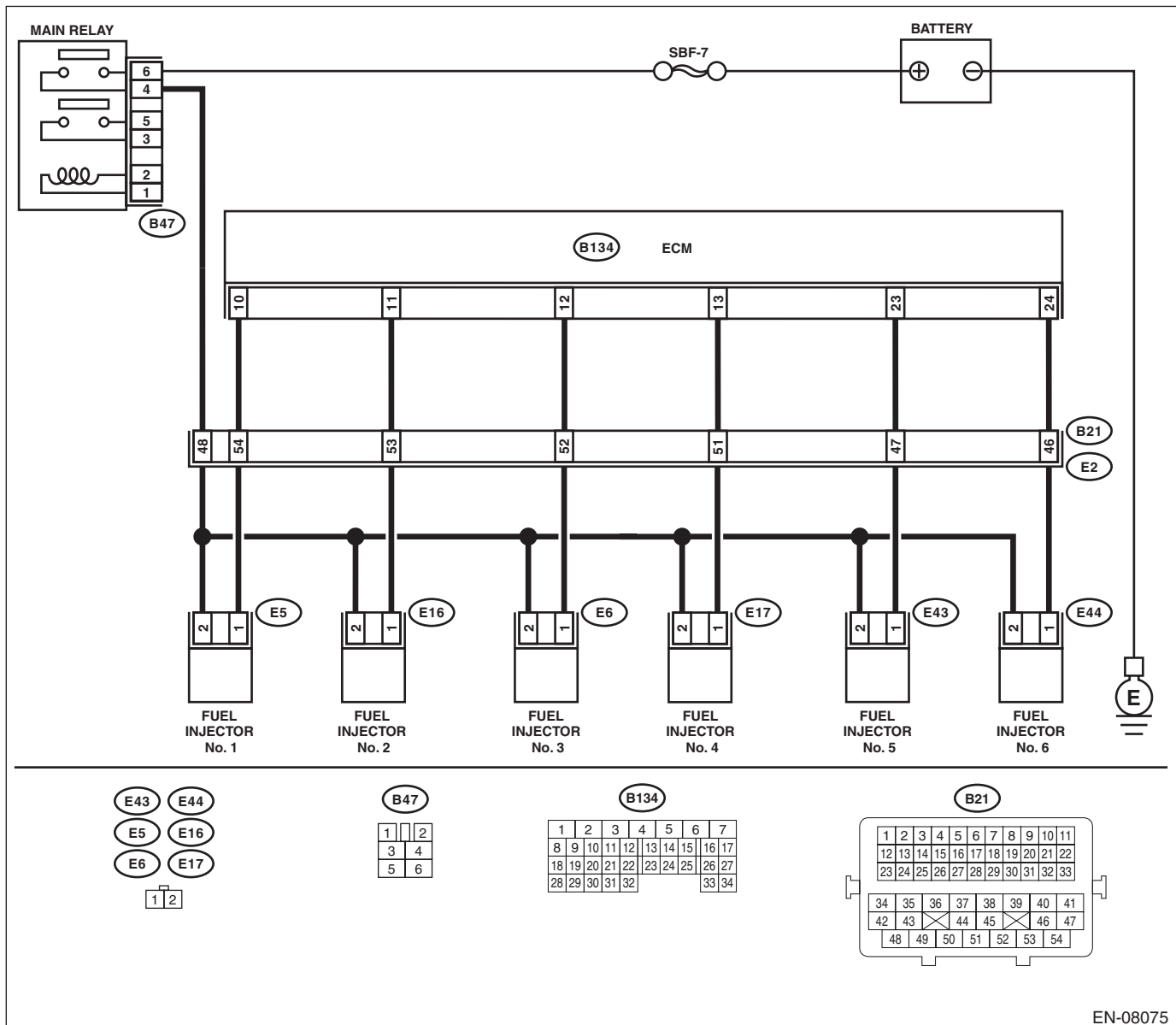

EN-08075

# Diagnostic Procedure with Diagnostic Trouble Code (DTC)

ENGINE (DIAGNOSTICS)

Step	Check	Yes	No
<p><b>1</b></p> <p><b>CHECK OUTPUT SIGNAL OF ECM.</b></p> <p>1) Turn the ignition switch to ON.</p> <p>2) Measure the voltage between ECM and chassis ground on faulty cylinders.</p> <p><b>Connector &amp; terminal</b></p> <p><b>#1 (B134) No. 10 (+) — Chassis ground (-):</b></p> <p><b>#2 (B134) No. 11 (+) — Chassis ground (-):</b></p> <p><b>#3 (B134) No. 12 (+) — Chassis ground (-):</b></p> <p><b>#4 (B134) No. 13 (+) — Chassis ground (-):</b></p> <p><b>#5 (B134) No. 23 (+) — Chassis ground (-):</b></p> <p><b>#6 (B134) No. 24 (+) — Chassis ground (-):</b></p>	Is the voltage 10 V or more?	Go to step 6.	Go to step 2.
<p><b>2</b></p> <p><b>CHECK HARNESS BETWEEN ECM AND FUEL INJECTOR.</b></p> <p>1) Turn the ignition switch to OFF.</p> <p>2) Disconnect the connector from fuel injector on faulty cylinders.</p> <p>3) Measure the resistance between fuel injector connector and engine ground on faulty cylinders.</p> <p><b>Connector &amp; terminal</b></p> <p><b>#1 (E5) No. 1 — Engine ground:</b></p> <p><b>#2 (E16) No. 1 — Engine ground:</b></p> <p><b>#3 (E6) No. 1 — Engine ground:</b></p> <p><b>#4 (E17) No. 1 — Engine ground:</b></p> <p><b>#5 (E43) No. 1 — Engine ground:</b></p> <p><b>#6 (E44) No. 1 — Engine ground:</b></p>	Is the resistance 1 M $\Omega$ or more?	Go to step 3.	Repair the short circuit to ground in harness between ECM and fuel injector connector.
<p><b>3</b></p> <p><b>CHECK HARNESS BETWEEN ECM AND FUEL INJECTOR.</b></p> <p>Measure the resistance of harness between ECM and fuel injector connector on faulty cylinders.</p> <p><b>Connector &amp; terminal</b></p> <p><b>#1 (B134) No. 10 — (E5) No. 1:</b></p> <p><b>#2 (B134) No. 11 — (E16) No. 1:</b></p> <p><b>#3 (B134) No. 12 — (E6) No. 1:</b></p> <p><b>#4 (B134) No. 13 — (E17) No. 1:</b></p> <p><b>#5 (B134) No. 23 — (E43) No. 1:</b></p> <p><b>#6 (B134) No. 24 — (E44) No. 1:</b></p>	Is the resistance less than 1 $\Omega$ ?	Go to step 4.	Repair the harness and connector. NOTE: In this case, repair the following item: • Open circuit in harness between ECM and fuel injector connector • Poor contact of coupling connector
<p><b>4</b></p> <p><b>CHECK FUEL INJECTOR.</b></p> <p>Measure the resistance between fuel injector terminals on faulty cylinder.</p> <p><b>Terminals</b></p> <p><b>No. 1 — No. 2:</b></p>	Is the resistance 5 — 20 $\Omega$ ?	Go to step 5.	Replace the faulty fuel injector. <Ref. to FU(H6DO)-42, Fuel Injector.>
<p><b>5</b></p> <p><b>CHECK POWER SUPPLY LINE.</b></p> <p>1) Turn the ignition switch to ON.</p> <p>2) Measure the voltage between fuel injector connector and engine ground on faulty cylinders.</p> <p><b>Connector &amp; terminal</b></p> <p><b>#1 (E5) No. 2 (+) — Engine ground (-):</b></p> <p><b>#2 (E16) No. 2 (+) — Engine ground (-):</b></p> <p><b>#3 (E6) No. 2 (+) — Engine ground (-):</b></p> <p><b>#4 (E17) No. 2 (+) — Engine ground (-):</b></p> <p><b>#5 (E43) No. 2 (+) — Engine ground (-):</b></p> <p><b>#6 (E44) No. 2 (+) — Engine ground (-):</b></p>	Is the voltage 10 V or more?	Repair the poor contact of all connectors in fuel injector circuit.	Repair the harness and connector. NOTE: In this case, repair the following item: • Open circuit in harness between the main relay and fuel injector connector on faulty cylinders • Poor contact of coupling connector • Poor contact of main relay connector

# Diagnostic Procedure with Diagnostic Trouble Code (DTC)

## ENGINE (DIAGNOSTICS)

Step	Check	Yes	No
<b>6 CHECK HARNESS BETWEEN ECM AND FUEL INJECTOR.</b> 1) Turn the ignition switch to OFF. 2) Disconnect the connector from fuel injector on faulty cylinders. 3) Turn the ignition switch to ON. 4) Measure the voltage between ECM and chassis ground on faulty cylinders. <b>Connector &amp; terminal</b> <b>#1 (B134) No. 10 (+) — Chassis ground (-):</b> <b>#2 (B134) No. 11 (+) — Chassis ground (-):</b> <b>#3 (B134) No. 12 (+) — Chassis ground (-):</b> <b>#4 (B134) No. 13 (+) — Chassis ground (-):</b> <b>#5 (B134) No. 23 (+) — Chassis ground (-):</b> <b>#6 (B134) No. 24 (+) — Chassis ground (-):</b>	Is the voltage 10 V or more?	Repair the short circuit to power in harness between ECM and fuel injector connector.	Go to step 7.
<b>7 CHECK FUEL INJECTOR.</b> 1) Turn the ignition switch to OFF. 2) Measure the resistance between fuel injector terminals on faulty cylinder. <b>Terminals</b> <b>No. 1 — No. 2:</b>	Is the resistance 5 — 20 Ω?	Go to step 8.	Replace the faulty fuel injector. <Ref. to FU(H6DO)-42, Fuel Injector.>
<b>8 CHECK INSTALLATION OF CAMSHAFT POSITION SENSOR/CRANKSHAFT POSITION SENSOR.</b>	Is the camshaft position sensor or crankshaft position sensor loosely installed?	Tighten the camshaft position sensor or crankshaft position sensor. <Ref. to FU(H6DO)-35, INSTALLATION, Camshaft Position Sensor.> <Ref. to FU(H6DO)-32, INSTALLATION, Crankshaft Position Sensor.>	Go to step 9.
<b>9 CHECK CRANK PLATE.</b>	Is the crank sprocket rusted or the teeth of crank plate broken?	Replace the crank plate. <Ref. to ME(H6DO)-97, Cylinder Block.>	Go to step 10.
<b>10 CHECK INSTALLATION CONDITION OF TIMING CHAIN.</b> Turn the crankshaft using ST, and align the alignment mark on crank sprocket with alignment mark on cylinder block. ST 18252AA000      CRANKSHAFT SOCKET	Is the timing chain dislocated from its proper position?	Correct the installation condition of timing chain. <Ref. to ME(H6DO)-54, Timing Chain Assembly.>	Go to step 11.
<b>11 CHECK FUEL LEVEL.</b>	Is the fuel meter indication lower than the “Lower” level?	Refill the fuel so that the fuel meter indication is higher than the “Lower” level, and proceed to the next step. Go to step 13.	Go to step 12.
<b>12 CHECK STATUS OF MALFUNCTION INDICATOR LIGHT.</b> 1) Clear the memory using the Subaru Select Monitor or general scan tool. <Ref. to EN(H6DO)(diag)-62, Clear Memory Mode.> 2) Start the engine, and drive the vehicle 10 minutes or more.	Does the malfunction indicator light illuminate or blink?	Go to step 14.	Go to step 13.



# Diagnostic Procedure with Diagnostic Trouble Code (DTC)

ENGINE (DIAGNOSTICS)

Step	Check	Yes	No
<b>13</b>	<b>CHECK CAUSE OF MISFIRE.</b>	Was the cause of misfire identified when the engine is running?	Finish diagnostics operation, if the engine has no abnormality.  Repair the poor contact of connector. NOTE: In this case, repair the following item: <ul style="list-style-type: none"> <li>• Poor contact of ignition coil connector</li> <li>• Poor contact of fuel injector connector on faulty cylinders</li> <li>• Poor contact of ECM connector</li> <li>• Poor contact of coupling connector</li> </ul>
<b>14</b>	<b>CHECK AIR INTAKE SYSTEM.</b>	Is there any fault in air intake system?	Repair the air intake system. NOTE: Check the following items. <ul style="list-style-type: none"> <li>• Are there air leaks or air suction caused by loose or dislocated nuts and bolts?</li> <li>• Are there cracks or any disconnection of hoses?</li> </ul>
<b>15</b>	<b>CHECK CYLINDER.</b>	Is there any fault in the cylinder?	Repair or replace faulty parts. NOTE: Check the following items. <ul style="list-style-type: none"> <li>• Spark plug</li> <li>• Ignition coil</li> <li>• Fuel injector</li> <li>• Compression ratio</li> <li>• Skipping timing chain teeth</li> </ul>

# Diagnostic Procedure with Diagnostic Trouble Code (DTC)

ENGINE (DIAGNOSTICS)

## CJ:DTC P0327 KNOCK SENSOR 1 CIRCUIT LOW (BANK 1 OR SINGLE SENSOR)

### DTC DETECTING CONDITION:

- Immediately at fault recognition
- GENERAL DESCRIPTION <Ref. to GD(H6DO)-118, DTC P0327 KNOCK SENSOR 1 CIRCUIT LOW (BANK 1 OR SINGLE SENSOR), Diagnostic Trouble Code (DTC) Detecting Criteria.>

### TROUBLE SYMPTOM:

- Poor driving performance
- Knocking occurs

### CAUTION:

After servicing or replacing faulty parts, perform Clear Memory Mode <Ref. to EN(H6DO)(diag)-62, OPERATION, Clear Memory Mode.>, and Inspection Mode <Ref. to EN(H6DO)(diag)-47, PROCEDURE, Inspection Mode.>.

### WIRING DIAGRAM:

Engine electrical system <Ref. to WI-32, Engine Electrical System.>

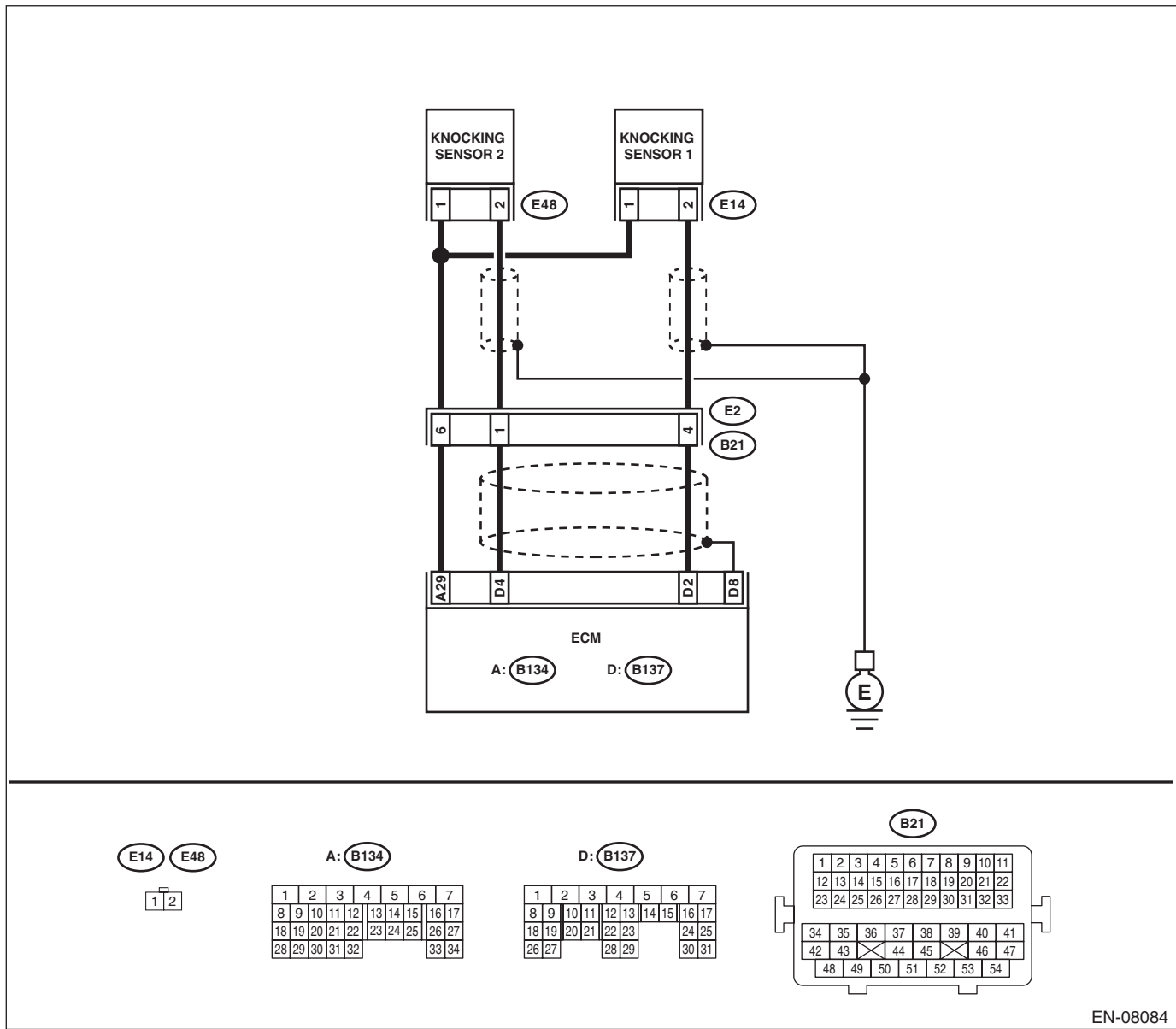

EN-08084

# Diagnostic Procedure with Diagnostic Trouble Code (DTC)

ENGINE (DIAGNOSTICS)

Step	Check	Yes	No
<p><b>1 CHECK HARNESS BETWEEN ECM AND KNOCK SENSOR CONNECTOR.</b>                      1) Turn the ignition switch to OFF.                      2) Disconnect the connector from ECM.                      3) Measure the resistance between ECM connectors.  <b>Connector &amp; terminal</b>  <b>(B137) No. 2 — (B134) No. 29:</b></p>	<p>Is the resistance less than 500 kΩ?</p>	<p>Go to step 2.</p>	<p>Go to step 3.</p>
<p><b>2 CHECK KNOCK SENSOR.</b>                      1) Disconnect the connector from the knock sensor.                      2) Measure the resistance between knock sensor connectors.  <b>Terminals</b>  <b>No. 1 — No. 2:</b></p>	<p>Is the resistance less than 500 kΩ?</p>	<p>Replace the knock sensor. &lt;Ref. to FU(H6DO)-37, Knock Sensor.&gt;</p>	<p>Repair the short circuit to ground in harness between ECM and knock sensor connector.                      NOTE:                      The harness between both connectors are shielded. Remove the shield and repair the short circuit of harness.</p>
<p><b>3 CHECK INPUT SIGNAL OF ECM.</b>                      1) Connect the connector to ECM.                      2) Turn the ignition switch to ON.                      3) Measure the voltage between ECM and chassis ground.  <b>Connector &amp; terminal</b>  <b>(B137) No. 2 (+) — Chassis ground (-):</b></p>	<p>Is the voltage 2 V or more?</p>	<p>Even if DTC is detected, the circuit has returned to a normal condition at this time. Reproduce the failure, and then perform the diagnosis again.                      NOTE:                      In this case, temporary poor contact of connector, temporary open or short circuit of harness may be the cause.</p>	<p>Repair the short circuit to ground in harness between ECM and knock sensor connector.                      NOTE:                      The harness between both connectors are shielded. Remove the shield and repair the short circuit of harness.</p>

# Diagnostic Procedure with Diagnostic Trouble Code (DTC)

ENGINE (DIAGNOSTICS)

## CK:DTC P0328 KNOCK SENSOR 1 CIRCUIT HIGH (BANK 1 OR SINGLE SENSOR)

### DTC DETECTING CONDITION:

- Immediately at fault recognition
- GENERAL DESCRIPTION <Ref. to GD(H6DO)-120, DTC P0328 KNOCK SENSOR 1 CIRCUIT HIGH (BANK 1 OR SINGLE SENSOR), Diagnostic Trouble Code (DTC) Detecting Criteria.>

### TROUBLE SYMPTOM:

- Poor driving performance
- Knocking occurs

### CAUTION:

After servicing or replacing faulty parts, perform Clear Memory Mode <Ref. to EN(H6DO)(diag)-62, OPERATION, Clear Memory Mode.>, and Inspection Mode <Ref. to EN(H6DO)(diag)-47, PROCEDURE, Inspection Mode.>.

### WIRING DIAGRAM:

Engine electrical system <Ref. to WI-32, Engine Electrical System.>

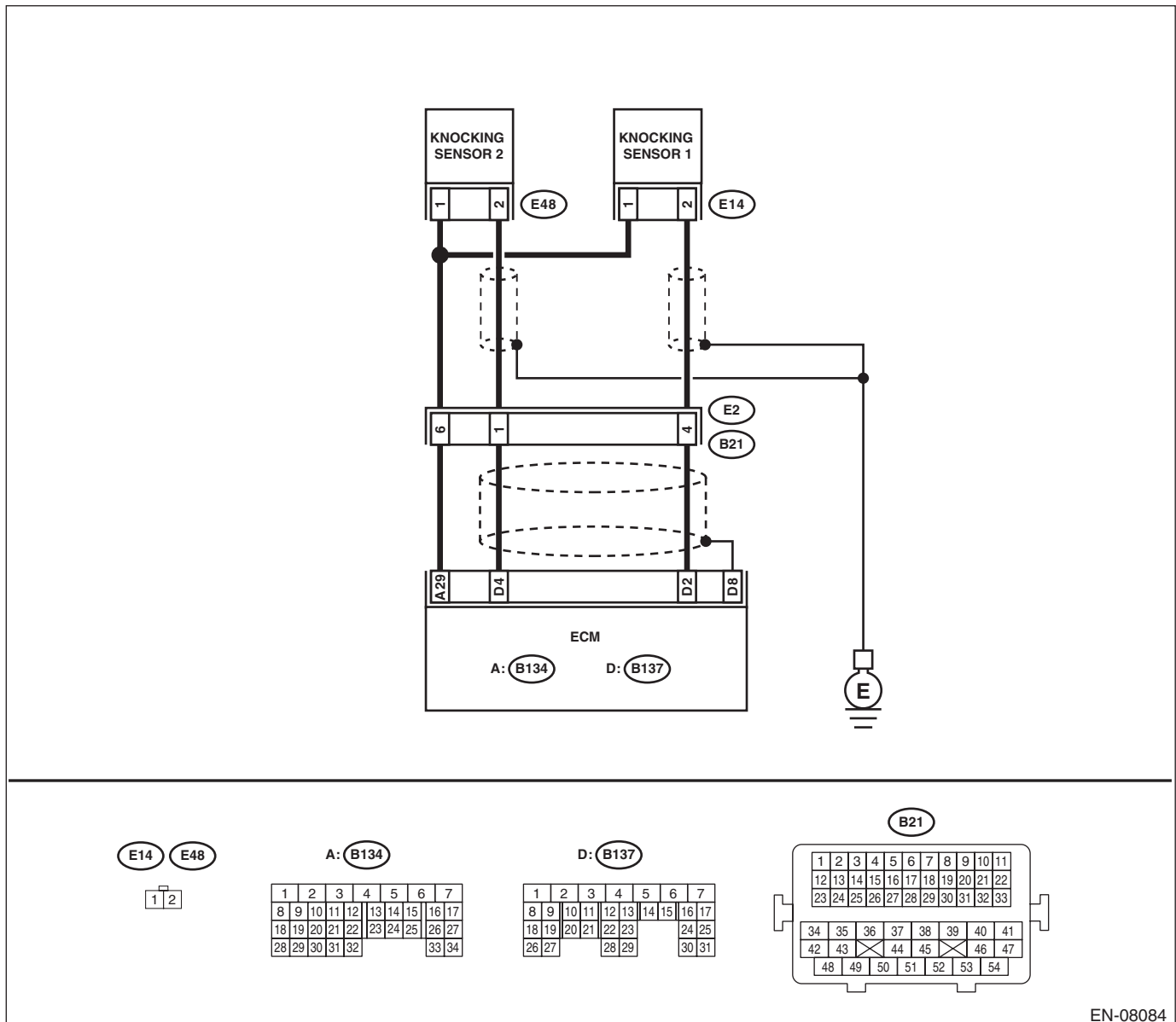

EN-08084

# Diagnostic Procedure with Diagnostic Trouble Code (DTC)

ENGINE (DIAGNOSTICS)

Step	Check	Yes	No
<p><b>1</b>     <b>CHECK HARNESS BETWEEN ECM AND KNOCK SENSOR CONNECTOR.</b>            1) Turn the ignition switch to OFF.            2) Disconnect the connector from ECM.            3) Measure the resistance between ECM connectors.  <b>Connector &amp; terminal</b>  <b>(B137) No. 2 — (B134) No. 29:</b></p>	<p>Is the resistance 600 kΩ or more?</p>	<p>Go to step 2.</p>	<p>Repair the poor contact of ECM connector.</p>
<p><b>2</b>     <b>CHECK KNOCK SENSOR.</b>            1) Disconnect the connector from the knock sensor.            2) Measure the resistance between knock sensor terminals.  <b>Terminals</b>  <b>No. 1 — No. 2:</b></p>	<p>Is the resistance 600 kΩ or more?</p>	<p>Replace the knock sensor. &lt;Ref. to FU(H6DO)-37, Knock Sensor.&gt;</p>	<p>Repair the harness and connector.  <b>NOTE:</b>            In this case, repair the following item:            • Open circuit in harness between ECM and knock sensor connector            • Poor contact of knock sensor connector            • Poor contact of coupling connector</p>

# Diagnostic Procedure with Diagnostic Trouble Code (DTC)

ENGINE (DIAGNOSTICS)

## CL:DTC P0332 KNOCK SENSOR 2 CIRCUIT LOW (BANK 2)

### DTC DETECTING CONDITION:

- Immediately at fault recognition
- GENERAL DESCRIPTION <Ref. to GD(H6DO)-121, DTC P0332 KNOCK SENSOR 2 CIRCUIT LOW (BANK 2), Diagnostic Trouble Code (DTC) Detecting Criteria.>

### TROUBLE SYMPTOM:

- Driving performance problem
- Knocking is occurred.

### CAUTION:

After servicing or replacing faulty parts, perform Clear Memory Mode <Ref. to EN(H6DO)(diag)-62, OPERATION, Clear Memory Mode.>, and Inspection Mode <Ref. to EN(H6DO)(diag)-47, PROCEDURE, Inspection Mode.>.

### WIRING DIAGRAM:

Engine electrical system <Ref. to WI-32, Engine Electrical System.>

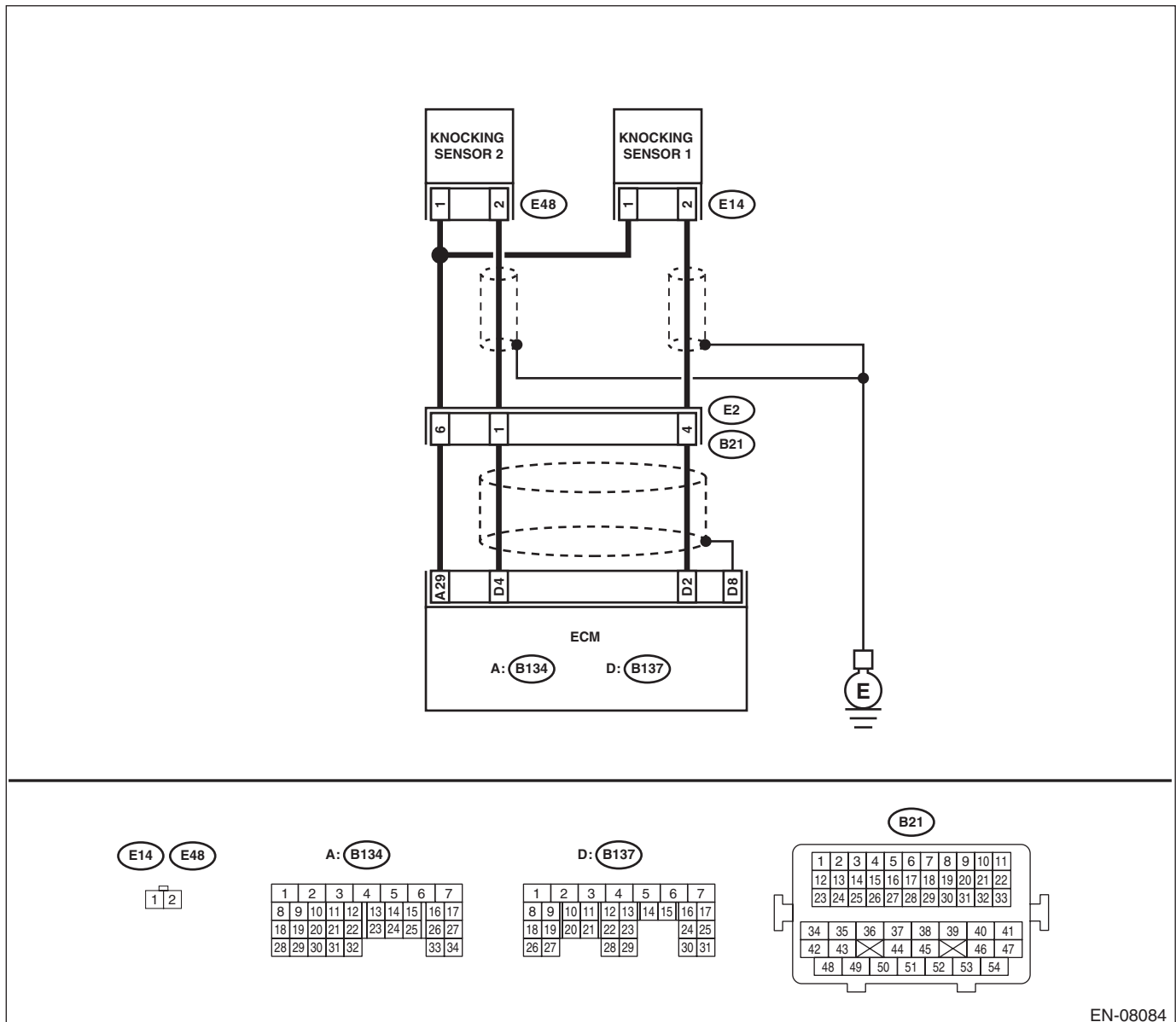

EN-08084

# Diagnostic Procedure with Diagnostic Trouble Code (DTC)

ENGINE (DIAGNOSTICS)

Step	Check	Yes	No
<p><b>1</b>     <b>CHECK HARNESS BETWEEN ECM AND KNOCK SENSOR CONNECTOR.</b>            1) Turn the ignition switch to OFF.            2) Disconnect the connector from ECM.            3) Measure the resistance between ECM connectors.  <b>Connector &amp; terminal</b>  <b>(B137) No. 4 — (B134) No. 29:</b></p>	<p>Is the resistance less than 500 kΩ?</p>	<p>Go to step 2.</p>	<p>Go to step 3.</p>
<p><b>2</b>     <b>CHECK KNOCK SENSOR.</b>            1) Disconnect the connector from the knock sensor.            2) Measure the resistance between knock sensor connectors.  <b>Terminals</b>  <b>No. 1 — No. 2:</b></p>	<p>Is the resistance less than 500 kΩ?</p>	<p>Replace the knock sensor. &lt;Ref. to FU(H6DO)-37, Knock Sensor.&gt;</p>	<p>Repair the short circuit to ground in harness between ECM and knock sensor connector.  <b>NOTE:</b>            The harness between both connectors are shielded. Remove the shield and repair the short circuit of harness.</p>
<p><b>3</b>     <b>CHECK INPUT SIGNAL OF ECM.</b>            1) Connect the connector to ECM.            2) Turn the ignition switch to ON.            3) Measure the voltage between ECM and chassis ground.  <b>Connector &amp; terminal</b>  <b>(B137) No. 4 (+) — Chassis ground (-):</b></p>	<p>Is the voltage 2 V or more?</p>	<p>Even if DTC is detected, the circuit has returned to a normal condition at this time. Reproduce the failure, and then perform the diagnosis again.  <b>NOTE:</b>            In this case, temporary poor contact of connector, temporary open or short circuit of harness may be the cause.</p>	<p>Repair the short circuit to ground in harness between ECM and knock sensor connector.  <b>NOTE:</b>            The harness between both connectors are shielded. Remove the shield and repair the short circuit of harness.</p>

# Diagnostic Procedure with Diagnostic Trouble Code (DTC)

ENGINE (DIAGNOSTICS)

## CM:DTC P0333 KNOCK SENSOR 2 CIRCUIT HIGH (BANK 2)

### DTC DETECTING CONDITION:

- Immediately at fault recognition
- GENERAL DESCRIPTION <Ref. to GD(H6DO)-121, DTC P0333 KNOCK SENSOR 2 CIRCUIT HIGH (BANK 2), Diagnostic Trouble Code (DTC) Detecting Criteria.>

### TROUBLE SYMPTOM:

- Driving performance problem
- Knocking occurs

### CAUTION:

After servicing or replacing faulty parts, perform Clear Memory Mode <Ref. to EN(H6DO)(diag)-62, OPERATION, Clear Memory Mode.>, and Inspection Mode <Ref. to EN(H6DO)(diag)-47, PROCEDURE, Inspection Mode.>.

### WIRING DIAGRAM:

Engine electrical system <Ref. to WI-32, Engine Electrical System.>

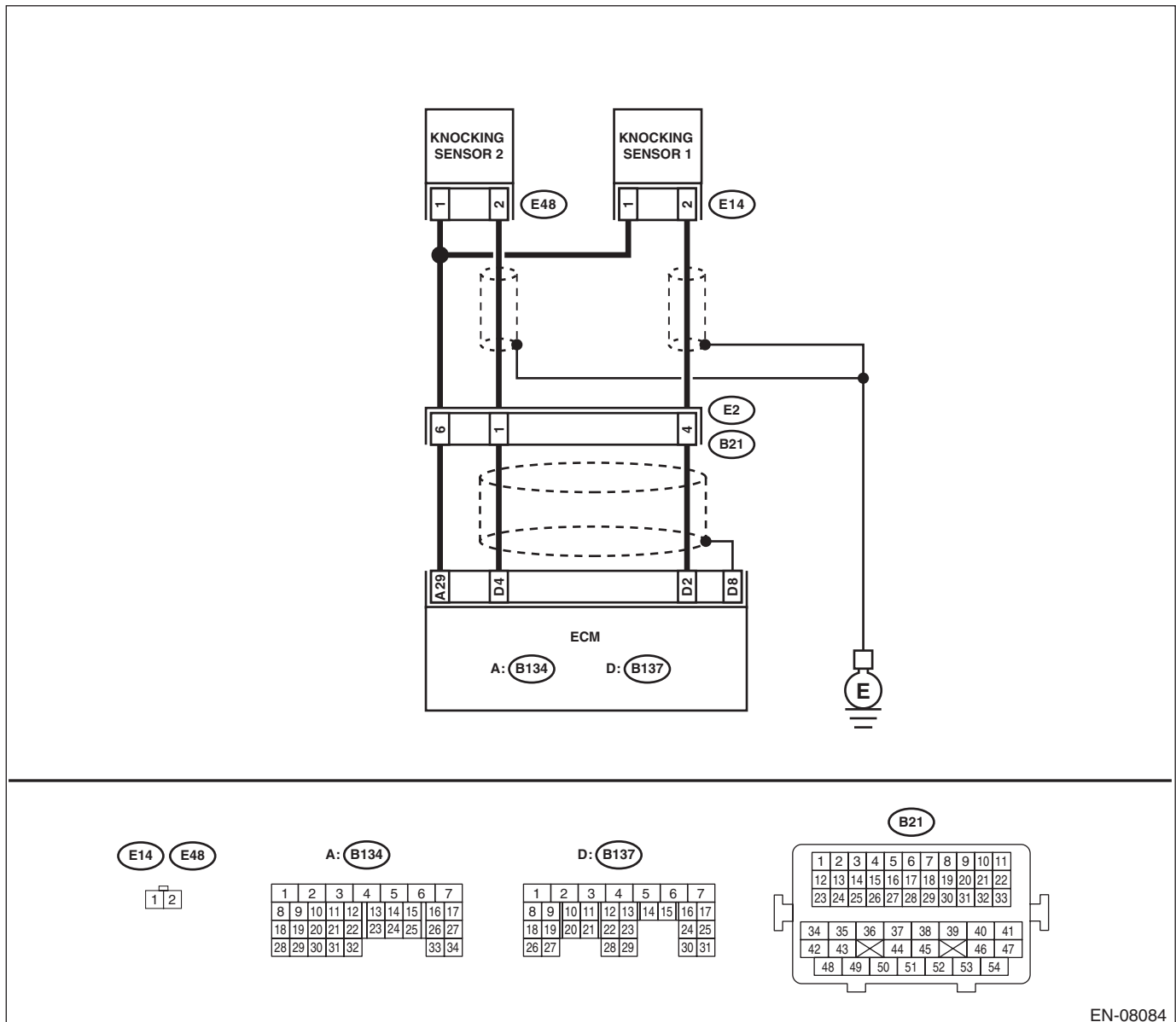

EN-08084



# Diagnostic Procedure with Diagnostic Trouble Code (DTC)

ENGINE (DIAGNOSTICS)

Step	Check	Yes	No
<b>1 CHECK HARNESS BETWEEN ECM AND KNOCK SENSOR CONNECTOR.</b> 1) Turn the ignition switch to OFF. 2) Disconnect the connector from ECM. 3) Measure the resistance between ECM connectors. <i>Connector &amp; terminal</i> <i>(B137) No. 4 — (B134) No. 29:</i>	Is the resistance 600 kΩ or more?	Go to step 2.	Repair the poor contact of ECM connector.
<b>2 CHECK KNOCK SENSOR.</b> 1) Disconnect the connector from the knock sensor. 2) Measure the resistance between knock sensor terminals. <i>Terminals</i> <i>No. 1 — No. 2:</i>	Is the resistance 600 kΩ or more?	Replace the knock sensor. <Ref. to FU(H6DO)-37, Knock Sensor.>	Repair the harness and connector. NOTE: In this case, repair the following item: <ul style="list-style-type: none"> <li>• Open circuit in harness between ECM and knock sensor connector</li> <li>• Poor contact of knock sensor connector</li> <li>• Poor contact of coupling connector</li> </ul>

# Diagnostic Procedure with Diagnostic Trouble Code (DTC)

ENGINE (DIAGNOSTICS)

## CN:DTC P0335 CRANKSHAFT POSITION SENSOR "A" CIRCUIT

### DTC DETECTING CONDITION:

- Immediately at fault recognition
- GENERAL DESCRIPTION <Ref. to GD(H6DO)-122, DTC P0335 CRANKSHAFT POSITION SENSOR "A" CIRCUIT, Diagnostic Trouble Code (DTC) Detecting Criteria.>

### TROUBLE SYMPTOM:

- Engine stalls.
- Failure of engine to start

### CAUTION:

After servicing or replacing faulty parts, perform Clear Memory Mode <Ref. to EN(H6DO)(diag)-62, OPERATION, Clear Memory Mode.>, and Inspection Mode <Ref. to EN(H6DO)(diag)-47, PROCEDURE, Inspection Mode.>.

### WIRING DIAGRAM:

Engine electrical system <Ref. to WI-32, Engine Electrical System.>

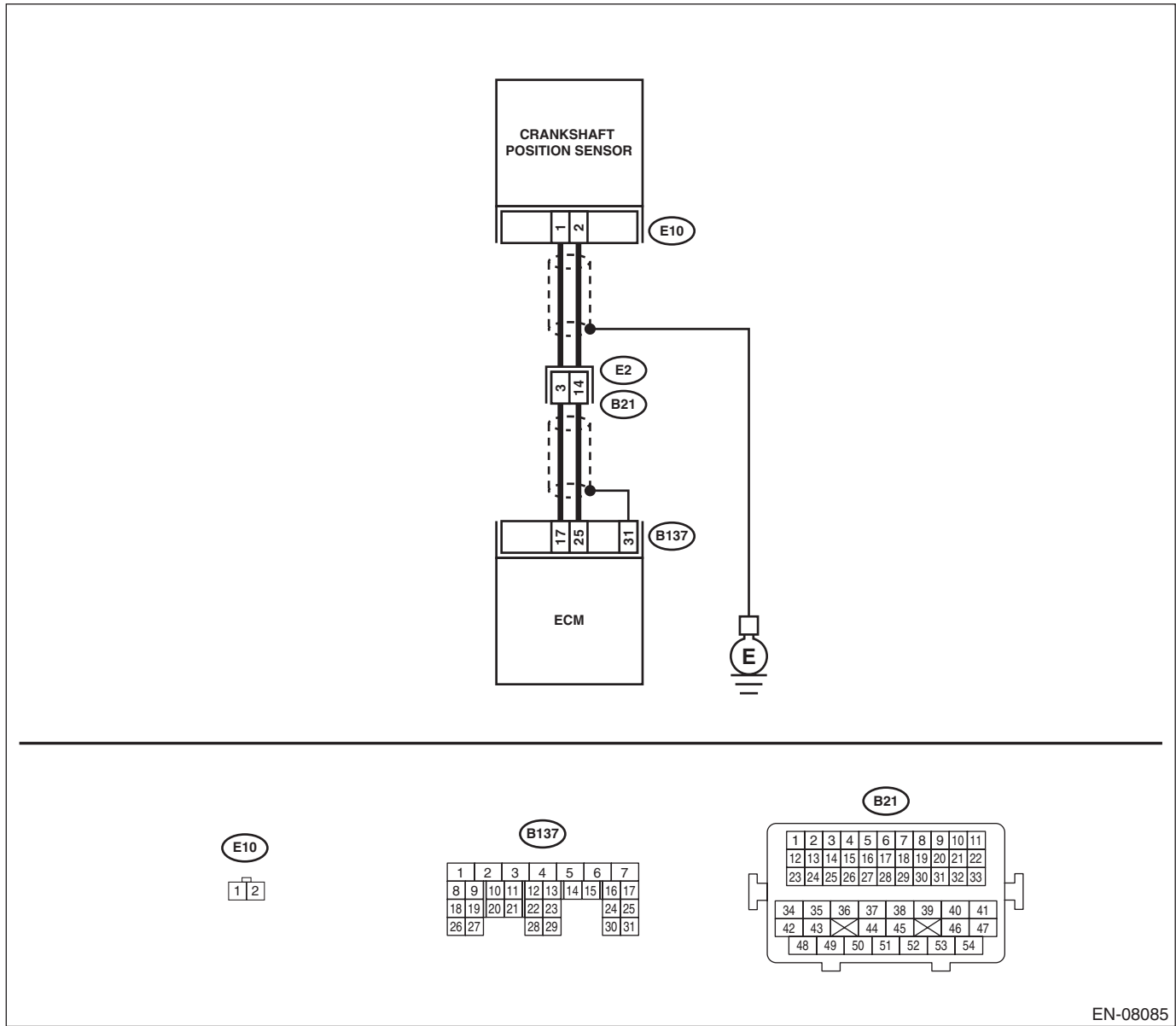

# Diagnostic Procedure with Diagnostic Trouble Code (DTC)

ENGINE (DIAGNOSTICS)

Step	Check	Yes	No
<b>1</b> <b>CHECK CONDITION OF CRANKSHAFT POSITION SENSOR.</b>	Is the crankshaft position sensor installation bolt tightened securely?	Go to step 2.	Tighten the crankshaft position sensor installation bolt securely.
<b>2</b> <b>CHECK CRANKSHAFT POSITION SENSOR.</b> 1) Turn the ignition switch to OFF. 2) Remove the crankshaft position sensor. 3) Measure the resistance between terminals of crankshaft position sensor connector. <b>Terminals</b> <b>No. 1 — No. 2:</b>	Is the resistance between 1 and 4 k $\Omega$ ?	Go to step 3.	Replace the crankshaft position sensor. <Ref. to FU(H6DO)-31, Crankshaft Position Sensor.>
<b>3</b> <b>CHECK HARNESS BETWEEN ECM AND CRANKSHAFT POSITION SENSOR CONNECTOR.</b> 1) Disconnect the connector from ECM. 2) Measure the resistance of harness between ECM and crankshaft position sensor connector. <b>Connector &amp; terminal</b> <b>(B137) No. 17 — (E10) No. 1:</b> <b>(B137) No. 25 — (E10) No. 2:</b>	Is the resistance less than 1 $\Omega$ ?	Repair the poor contact of ECM and crankshaft position sensor connector.	Repair the harness and connector. NOTE: In this case, repair the following item: <ul style="list-style-type: none"> <li>• Open circuit in harness between ECM and crankshaft position sensor connector</li> <li>• Poor contact of coupling connector</li> </ul>

# Diagnostic Procedure with Diagnostic Trouble Code (DTC)

ENGINE (DIAGNOSTICS)

## CO:DTC P0336 CRANKSHAFT POSITION SENSOR “A” CIRCUIT RANGE/PERFORMANCE

### DTC DETECTING CONDITION:

- Detected when two consecutive driving cycles with fault occur.
- GENERAL DESCRIPTION <Ref. to GD(H6DO)-124, DTC P0336 CRANKSHAFT POSITION SENSOR “A” CIRCUIT RANGE/PERFORMANCE, Diagnostic Trouble Code (DTC) Detecting Criteria.>

### TROUBLE SYMPTOM:

- Engine stalls.
- Failure of engine to start

### CAUTION:

After servicing or replacing faulty parts, perform Clear Memory Mode <Ref. to EN(H6DO)(diag)-62, OPERATION, Clear Memory Mode.>, and Inspection Mode <Ref. to EN(H6DO)(diag)-47, PROCEDURE, Inspection Mode.>.

	Step	Check	Yes	No
1	<b>CHECK CONDITION OF CRANKSHAFT POSITION SENSOR.</b> Turn the ignition switch to OFF.	Is the crankshaft position sensor installation bolt tightened securely?	Go to step 2.	Tighten the crankshaft position sensor installation bolt securely.
2	<b>CHECK CRANKSHAFT PLATE.</b>	Is there crack or damage in the crankshaft plate teeth?	Replace the crankshaft plate.	Go to step 3.
3	<b>CHECK INSTALLATION CONDITION OF TIMING CHAIN.</b> Turn the crankshaft, and align alignment mark on crank sprocket with alignment mark on cylinder block. ST 18252AA000      CRANKSHAFT SOCKET	Is the timing chain dislocated from its proper position?	Correct the installation condition of timing chain. <Ref. to ME(H6DO)-54, Timing Chain Assembly.>	Replace the crankshaft position sensor. <Ref. to FU(H6DO)-31, Crankshaft Position Sensor.>

## CP:DTC P0340 CAMSHAFT POSITION SENSOR "A" CIRCUIT (BANK 1 OR SINGLE SENSOR)

### DTC DETECTING CONDITION:

- Immediately at fault recognition
- GENERAL DESCRIPTION <Ref. to GD(H6DO)-126, DTC P0340 CAMSHAFT POSITION SENSOR "A" CIRCUIT (BANK 1 OR SINGLE SENSOR), Diagnostic Trouble Code (DTC) Detecting Criteria.>

### TROUBLE SYMPTOM:

- Engine stalls.
- Failure of engine to start

### CAUTION:

After servicing or replacing faulty parts, perform Clear Memory Mode <Ref. to EN(H6DO)(diag)-62, OPERATION, Clear Memory Mode.>, and Inspection Mode <Ref. to EN(H6DO)(diag)-47, PROCEDURE, Inspection Mode.>.

### WIRING DIAGRAM:

Engine electrical system <Ref. to WI-32, Engine Electrical System.>

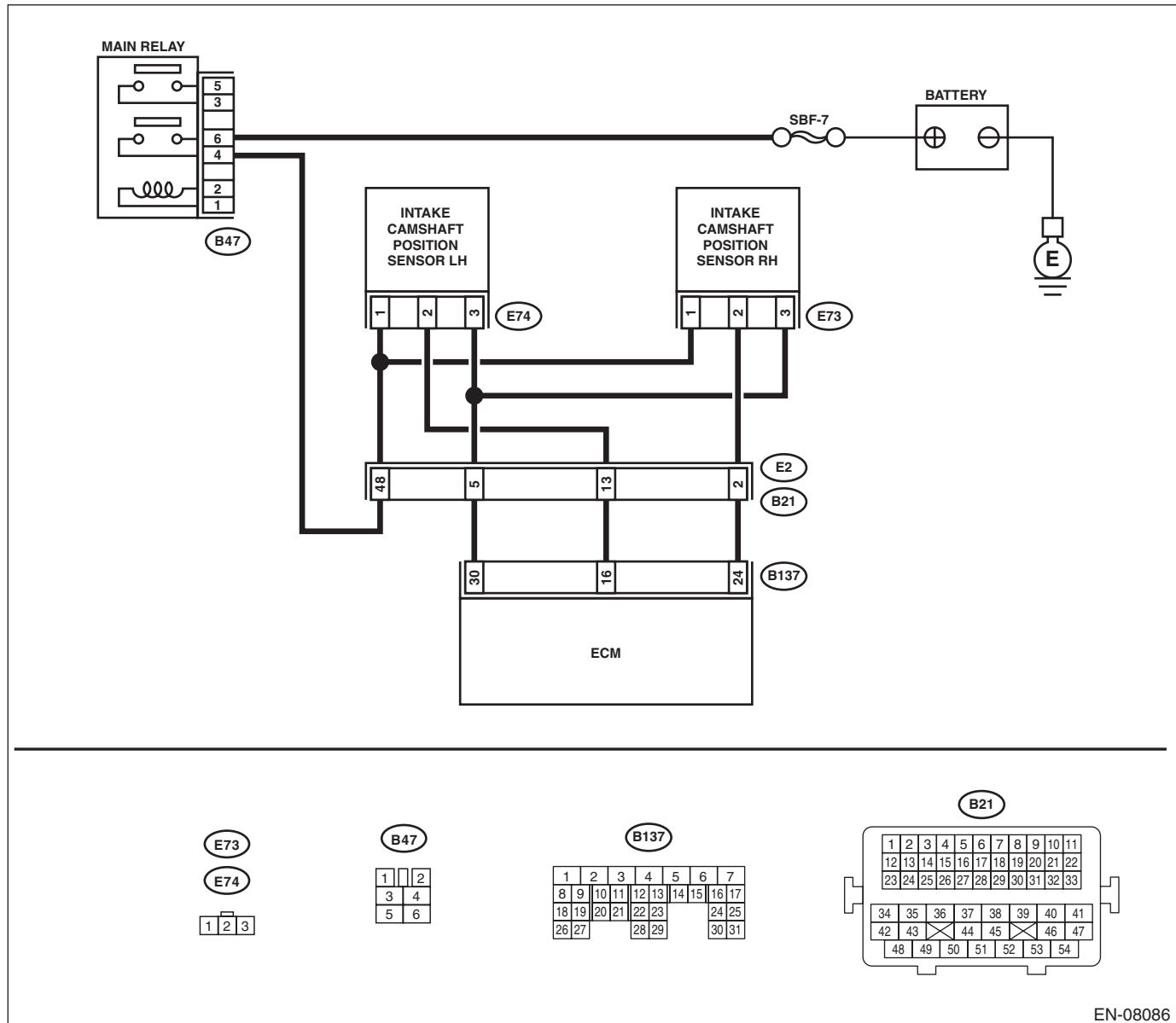

# Diagnostic Procedure with Diagnostic Trouble Code (DTC)

## ENGINE (DIAGNOSTICS)

Step	Check	Yes	No
<b>1 CHECK POWER SUPPLY OF CAMSHAFT POSITION SENSOR.</b> 1) Turn the ignition switch to OFF. 2) Disconnect the connector from camshaft position sensor. 3) Turn the ignition switch to ON. 4) Measure the voltage between camshaft position sensor connector and engine ground. <b>Connector &amp; terminal</b> <b>(E73) No. 1 (+) — Engine ground (-):</b>	Is the voltage 10 V or more?	Go to step 2.	Repair the harness and connector.  NOTE: In this case, repair the following item: <ul style="list-style-type: none"> <li>• Open circuit or short circuit to ground in harness between main relay connector and camshaft position sensor connector</li> <li>• Poor contact of coupling connector</li> </ul>
<b>2 CHECK HARNESS BETWEEN ECM AND CAMSHAFT POSITION SENSOR CONNECTOR.</b> 1) Turn the ignition switch to OFF. 2) Disconnect the connector from ECM. 3) Measure the resistance between ECM and camshaft position sensor connector. <b>Connector &amp; terminal</b> <b>(B137) No. 24 — (E73) No. 2:</b> <b>(B137) No. 30 — (E73) No. 3:</b>	Is the resistance less than 1 $\Omega$ ?	Go to step 3.	Repair the harness and connector.  NOTE: In this case, repair the following item: <ul style="list-style-type: none"> <li>• Open circuit in harness between ECM and camshaft position sensor connector</li> <li>• Poor contact of coupling connector</li> </ul>
<b>3 CHECK HARNESS BETWEEN ECM AND CAMSHAFT POSITION SENSOR CONNECTOR.</b> Measure the resistance between camshaft position sensor connector and engine ground. <b>Connector &amp; terminal</b> <b>(E73) No. 2 — Engine ground:</b>	Is the resistance 1 M $\Omega$ or more?	Go to step 4.	Repair short circuit to ground in harness between ECM and camshaft position sensor connector.
<b>4 CHECK HARNESS BETWEEN ECM AND CAMSHAFT POSITION SENSOR CONNECTOR.</b> Measure the voltage between camshaft position sensor connector and engine ground. <b>Connector &amp; terminal</b> <b>(E73) No. 2 (+) — Engine ground (-):</b>	Is the voltage 5 V or more?	Repair the short circuit to power in the harness between ECM and camshaft position sensor connector.	Go to step 5.
<b>5 CHECK CONDITION OF CAMSHAFT POSITION SENSOR.</b>	Is the camshaft position sensor installation bolt tightened securely?	Go to step 6.	Tighten the camshaft position sensor installation bolt securely.
<b>6 CHECK CAMSHAFT POSITION SENSOR.</b> Check the waveform of the camshaft position sensor. <Ref. to EN(H6DO)(diag)-18, Engine Control Module (ECM) I/O Signal.>	Is there any abnormality in waveform?	Replace the camshaft position sensor. <Ref. to FU(H6DO)-34, Camshaft Position Sensor.>	Repair the following item. <ul style="list-style-type: none"> <li>• Poor contact of ECM connector</li> <li>• Poor contact of camshaft position sensor connector</li> <li>• Poor contact of coupling connector</li> </ul>

## Diagnostic Procedure with Diagnostic Trouble Code (DTC)

ENGINE (DIAGNOSTICS)

---

### **CQ:DTC P0341 CAMSHAFT POSITION SENSOR “A” CIRCUIT RANGE/PERFORMANCE (BANK 1 OR SINGLE SENSOR)**

**NOTE:**

For the diagnostic procedure, refer to DTC P0340. <Ref. to EN(H6DO)(diag)-223, DTC P0340 CAMSHAFT POSITION SENSOR “A” CIRCUIT (BANK 1 OR SINGLE SENSOR), Diagnostic Procedure with Diagnostic Trouble Code (DTC).>

# Diagnostic Procedure with Diagnostic Trouble Code (DTC)

ENGINE (DIAGNOSTICS)

## CR:DTC P0345 CAMSHAFT POSITION SENSOR "A" CIRCUIT (BANK 2)

### DTC DETECTING CONDITION:

- Immediately at fault recognition
- GENERAL DESCRIPTION <Ref. to GD(H6DO)-129, DTC P0345 CAMSHAFT POSITION SENSOR "A" CIRCUIT (BANK 2), Diagnostic Trouble Code (DTC) Detecting Criteria.>

### TROUBLE SYMPTOM:

- Engine stalls.
- Failure of engine to start

### CAUTION:

After servicing or replacing faulty parts, perform Clear Memory Mode <Ref. to EN(H6DO)(diag)-62, OPERATION, Clear Memory Mode.>, and Inspection Mode <Ref. to EN(H6DO)(diag)-47, PROCEDURE, Inspection Mode.>.

### WIRING DIAGRAM:

Engine electrical system <Ref. to WI-32, Engine Electrical System.>

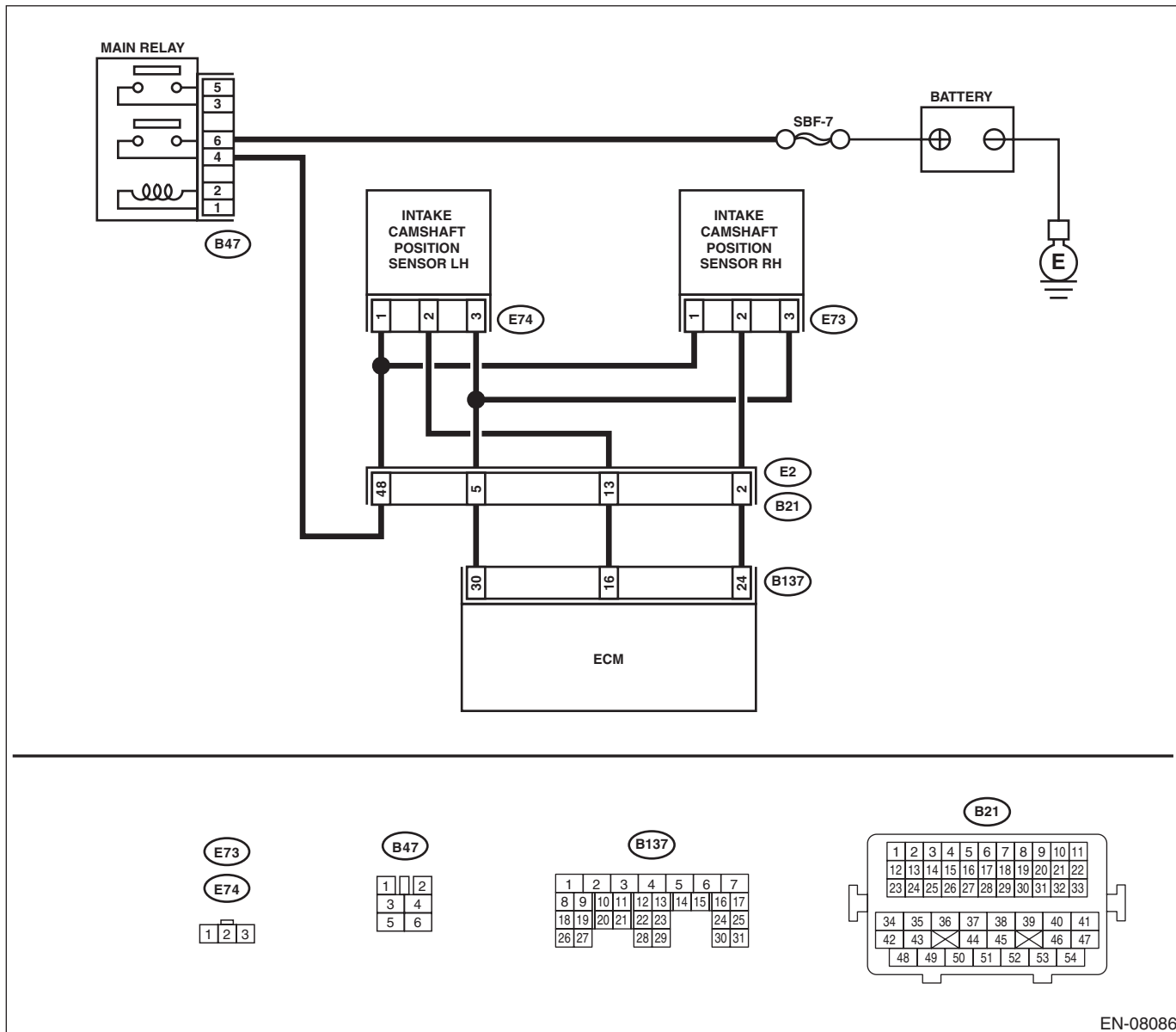

EN-08086



# Diagnostic Procedure with Diagnostic Trouble Code (DTC)

ENGINE (DIAGNOSTICS)

Step	Check	Yes	No
<p><b>1 CHECK POWER SUPPLY OF CAMSHAFT POSITION SENSOR.</b></p> <p>1) Turn the ignition switch to OFF.                      2) Disconnect the connector from camshaft position sensor.                      3) Turn the ignition switch to ON.                      4) Measure the voltage between camshaft position sensor connector and engine ground.</p> <p><b>Connector &amp; terminal</b>  <b>(E74) No. 1 (+) — Engine ground (-):</b></p>	Is the voltage 10 V or more?	Go to step 2.	Repair the harness and connector.  NOTE: In this case, repair the following item: • Open circuit or short circuit to ground in harness between main relay connector and camshaft position sensor connector • Poor contact of coupling connector
<p><b>2 CHECK HARNESS BETWEEN ECM AND CAMSHAFT POSITION SENSOR CONNECTOR.</b></p> <p>1) Turn the ignition switch to OFF.                      2) Disconnect the connector from ECM.                      3) Measure the resistance between ECM and camshaft position sensor connector.</p> <p><b>Connector &amp; terminal</b>  <b>(B137) No. 16 — (E74) No. 2:</b>  <b>(B137) No. 30 — (E74) No. 3:</b></p>	Is the resistance less than 1 Ω?	Go to step 3.	Repair the harness and connector.  NOTE: In this case, repair the following item: • Open circuit in harness between ECM and camshaft position sensor connector • Poor contact of coupling connector
<p><b>3 CHECK HARNESS BETWEEN ECM AND CAMSHAFT POSITION SENSOR CONNECTOR.</b></p> <p>Measure the resistance between camshaft position sensor connector and engine ground.</p> <p><b>Connector &amp; terminal</b>  <b>(E74) No. 2 — Engine ground:</b></p>	Is the resistance 1 MΩ or more?	Go to step 4.	Repair short circuit to ground in harness between ECM and camshaft position sensor connector.
<p><b>4 CHECK HARNESS BETWEEN ECM AND CAMSHAFT POSITION SENSOR CONNECTOR.</b></p> <p>Measure the voltage between camshaft position sensor connector and engine ground.</p> <p><b>Connector &amp; terminal</b>  <b>(E74) No. 2 (+) — Engine ground (-):</b></p>	Is the voltage 5 V or more?	Repair the short circuit to power in the harness between ECM and camshaft position sensor connector.	Go to step 5.
<p><b>5 CHECK CONDITION OF CAMSHAFT POSITION SENSOR.</b></p>	Is the camshaft position sensor installation bolt tightened securely?	Go to step 6.	Tighten the camshaft position sensor installation bolt securely.
<p><b>6 CHECK CAMSHAFT POSITION SENSOR.</b></p> <p>Check the waveform of the camshaft position sensor. &lt;Ref. to EN(H6DO)(diag)-18, Engine Control Module (ECM) I/O Signal.&gt;</p>	Is there any abnormality in waveform?	Replace the camshaft position sensor. <Ref. to FU(H6DO)-34, Camshaft Position Sensor.>	Repair the following item. • Poor contact of ECM connector • Poor contact of camshaft position sensor connector • Poor contact of coupling connector

## **Diagnostic Procedure with Diagnostic Trouble Code (DTC)**

ENGINE (DIAGNOSTICS)

---

### **CS:DTC P0346 CAMSHAFT POSITION SENSOR “A” CIRCUIT RANGE/PERFORMANCE (BANK 2)**

**NOTE:**

For the diagnostic procedure, refer to DTC P0345. <Ref. to EN(H6DO)(diag)-226, DTC P0345 CAMSHAFT POSITION SENSOR “A” CIRCUIT (BANK 2), Diagnostic Procedure with Diagnostic Trouble Code (DTC).>

# Diagnostic Procedure with Diagnostic Trouble Code (DTC)

ENGINE (DIAGNOSTICS)

## CT:DTC P0351 IGNITION COIL A PRIMARY/SECONDARY CIRCUIT

### DTC DETECTING CONDITION:

- Immediately at fault recognition
- GENERAL DESCRIPTION <Ref. to GD(H6DO)-130, DTC P0351 IGNITION COIL A PRIMARY/SECONDARY CIRCUIT, Diagnostic Trouble Code (DTC) Detecting Criteria.>

### TROUBLE SYMPTOM:

- Improper idling
- Poor driving performance

### CAUTION:

After servicing or replacing faulty parts, perform Clear Memory Mode <Ref. to EN(H6DO)(diag)-62, OPERATION, Clear Memory Mode.>, and Inspection Mode <Ref. to EN(H6DO)(diag)-47, PROCEDURE, Inspection Mode.>.

### WIRING DIAGRAM:

Engine electrical system <Ref. to WI-32, Engine Electrical System.>

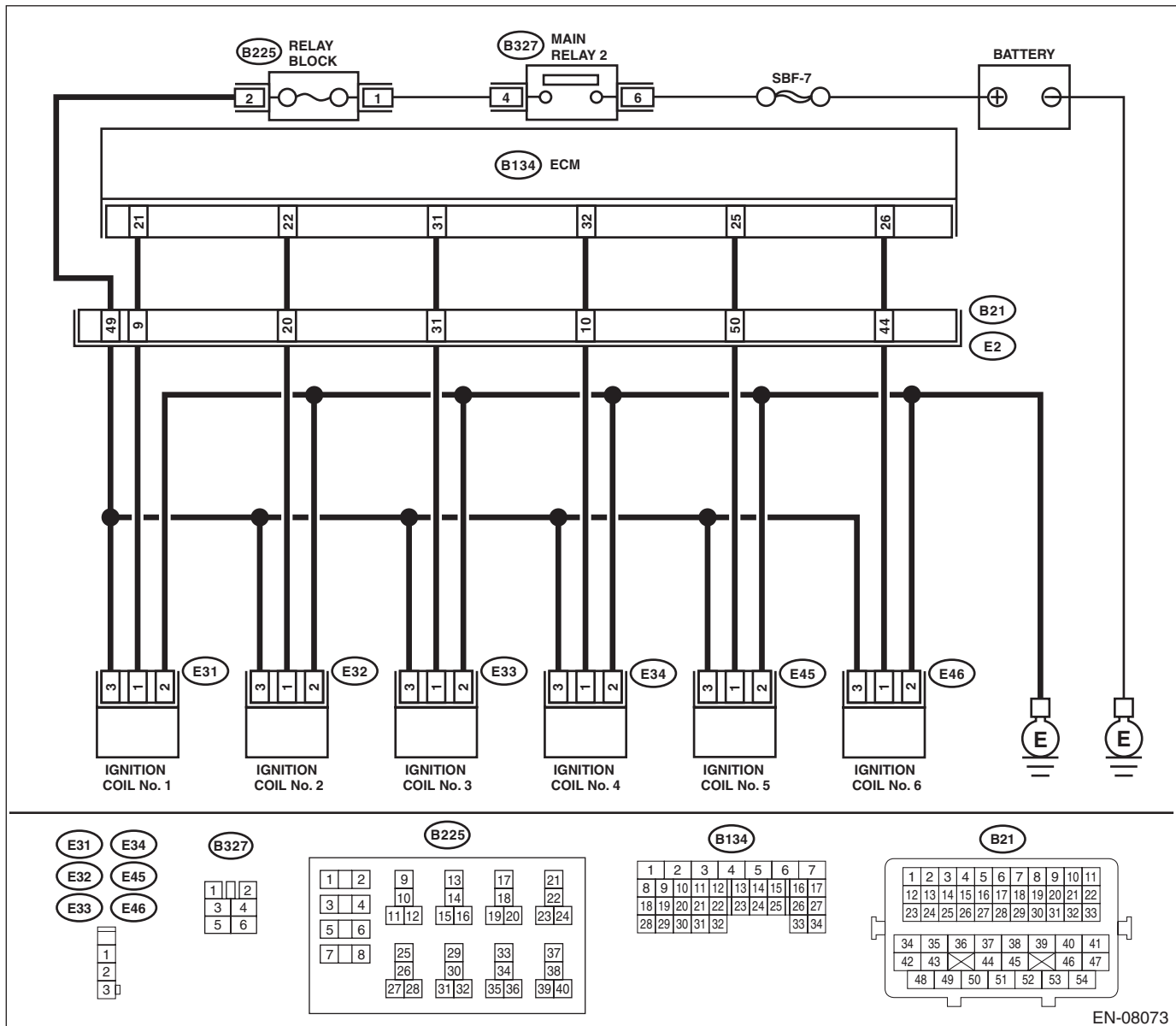

EN-08073

# Diagnostic Procedure with Diagnostic Trouble Code (DTC)

## ENGINE (DIAGNOSTICS)

Step	Check	Yes	No
<p><b>1 CHECK IGNITION COIL POWER SUPPLY CIRCUIT.</b></p> <p>1) Turn the ignition switch to OFF.                      2) Disconnect the connector from ignition coil.                      3) Turn the ignition switch to ON.                      4) Measure the voltage between ignition coil connector and engine ground.</p> <p><b>Connector &amp; terminal</b>  <b>DTC P0351; (E31) No. 3 (+) — Engine ground (-):</b>  <b>DTC P0352; (E32) No. 3 (+) — Engine ground (-):</b>  <b>DTC P0353; (E33) No. 3 (+) — Engine ground (-):</b>  <b>DTC P0354; (E34) No. 3 (+) — Engine ground (-):</b>  <b>DTC P0355; (E45) No. 3 (+) — Engine ground (-):</b>  <b>DTC P0356; (E46) No. 3 (+) — Engine ground (-):</b></p>	Is the voltage 10 V or more?	Go to step 2.	Repair the harness and connector.  NOTE: In this case, repair the following item: • Open circuit or short circuit to ground in harness of power supply circuit • Blown out of fuse • Poor contact of IG relay connector • Poor contact of coupling connector • Defective main relay 2
<p><b>2 CHECK HARNESS OF IGNITION COIL GROUND CIRCUIT.</b></p> <p>1) Turn the ignition switch to OFF.                      2) Measure the resistance of harness between ignition coil connector and engine ground.</p> <p><b>Connector &amp; terminal</b>  <b>DTC P0351; (E31) No. 2 — Engine ground:</b>  <b>DTC P0352; (E32) No. 2 — Engine ground:</b>  <b>DTC P0353; (E33) No. 2 — Engine ground:</b>  <b>DTC P0354; (E34) No. 2 — Engine ground:</b>  <b>DTC P0355; (E45) No. 2 — Engine ground:</b>  <b>DTC P0356; (E46) No. 2 — Engine ground:</b></p>	Is the resistance less than 5 Ω?	Go to step 3.	Repair the open circuit in harness between ignition coil connector and engine grounding terminal.
<p><b>3 CHECK HARNESS BETWEEN ECM AND IGNITION COIL CONNECTOR.</b></p> <p>1) Disconnect the connector from ECM.                      2) Measure the resistance between ignition coil connector and engine ground.</p> <p><b>Connector &amp; terminal</b>  <b>DTC P0351; (E31) No. 1 — Engine ground:</b>  <b>DTC P0352; (E32) No. 1 — Engine ground:</b>  <b>DTC P0353; (E33) No. 1 — Engine ground:</b>  <b>DTC P0354; (E34) No. 1 — Engine ground:</b>  <b>DTC P0355; (E45) No. 1 — Engine ground:</b>  <b>DTC P0356; (E46) No. 1 — Engine ground:</b></p>	Is the resistance 1 MΩ or more?	Go to step 4.	Repair the ground short circuit of harness between ECM connector and ignition coil connector.
<p><b>4 CHECK HARNESS BETWEEN ECM AND IGNITION COIL CONNECTOR.</b></p> <p>Measure the resistance of harness between ECM connector and ignition coil connector.</p> <p><b>Connector &amp; terminal</b>  <b>DTC P0351; (B134) No. 21 — (E31) No. 1:</b>  <b>DTC P0352; (B134) No. 22 — (E32) No. 1:</b>  <b>DTC P0353; (B134) No. 31 — (E33) No. 1:</b>  <b>DTC P0354; (B134) No. 32 — (E34) No. 1:</b>  <b>DTC P0355; (B134) No. 25 — (E45) No. 1:</b>  <b>DTC P0356; (B134) No. 26 — (E46) No. 1:</b></p>	Is the resistance less than 1 Ω?	Go to step 5.	Repair the harness and connector.  NOTE: In this case, repair the following item: • Open circuit of harness between ECM connector and the ignition coil connector • Poor contact of coupling connector
<p><b>5 CHECK FOR POOR CONTACT.</b></p> <p>Check for poor contact of ECM connector.</p>	Is there poor contact of ECM connector?	Repair the poor contact of ECM connector.	Go to step 6.

# Diagnostic Procedure with Diagnostic Trouble Code (DTC)

ENGINE (DIAGNOSTICS)

Step	Check	Yes	No
<b>6</b> <b>CHECK SPARK PLUG CONDITION.</b> 1) Remove the spark plug of the corresponding cylinder. <Ref. to IG(H6DO)-4, REMOVAL, Spark Plug.> 2) Check the spark plug condition. <Ref. to IG(H6DO)-5, INSPECTION, Spark Plug.>	Is the spark plug condition normal?	Replace the ignition coil. <Ref. to IG(H6DO)-7, Ignition Coil.>	Replace the spark plug. <Ref. to IG(H6DO)-4, Spark Plug.>

## **CU:DTC P0352 IGNITION COIL B PRIMARY/SECONDARY CIRCUIT**

NOTE:

For the diagnostic procedure, refer to DTC P0351. <Ref. to EN(H6DO)(diag)-229, DTC P0351 IGNITION COIL A PRIMARY/SECONDARY CIRCUIT, Diagnostic Procedure with Diagnostic Trouble Code (DTC).>

## **CV:DTC P0353 IGNITION COIL C PRIMARY/SECONDARY CIRCUIT**

NOTE:

For the diagnostic procedure, refer to DTC P0351. <Ref. to EN(H6DO)(diag)-229, DTC P0351 IGNITION COIL A PRIMARY/SECONDARY CIRCUIT, Diagnostic Procedure with Diagnostic Trouble Code (DTC).>

## **CW:DTC P0354 IGNITION COIL D PRIMARY/SECONDARY CIRCUIT**

NOTE:

For the diagnostic procedure, refer to DTC P0351. <Ref. to EN(H6DO)(diag)-229, DTC P0351 IGNITION COIL A PRIMARY/SECONDARY CIRCUIT, Diagnostic Procedure with Diagnostic Trouble Code (DTC).>

## **CX:DTC P0355 IGNITION COIL E PRIMARY/SECONDARY CIRCUIT**

NOTE:

For the diagnostic procedure, refer to DTC P0351. <Ref. to EN(H6DO)(diag)-229, DTC P0351 IGNITION COIL A PRIMARY/SECONDARY CIRCUIT, Diagnostic Procedure with Diagnostic Trouble Code (DTC).>

## **CY:DTC P0356 IGNITION COIL F PRIMARY/SECONDARY CIRCUIT**

NOTE:

For the diagnostic procedure, refer to DTC P0351. <Ref. to EN(H6DO)(diag)-229, DTC P0351 IGNITION COIL A PRIMARY/SECONDARY CIRCUIT, Diagnostic Procedure with Diagnostic Trouble Code (DTC).>

# Diagnostic Procedure with Diagnostic Trouble Code (DTC)

ENGINE (DIAGNOSTICS)

## CZ:DTC P0365 CAMSHAFT POSITION SENSOR "B" CIRCUIT (BANK 1)

### DTC DETECTING CONDITION:

- Immediately at fault recognition
- GENERAL DESCRIPTION <Ref. to GD(H6DO)-132, DTC P0365 CAMSHAFT POSITION SENSOR "B" CIRCUIT (BANK 1), Diagnostic Trouble Code (DTC) Detecting Criteria.>

### TROUBLE SYMPTOM:

- Engine stalls.
- Failure of engine to start

### CAUTION:

After servicing or replacing faulty parts, perform Clear Memory Mode <Ref. to EN(H6DO)(diag)-62, OPERATION, Clear Memory Mode.>, and Inspection Mode <Ref. to EN(H6DO)(diag)-47, PROCEDURE, Inspection Mode.>.

### WIRING DIAGRAM:

Engine electrical system <Ref. to WI-32, Engine Electrical System.>

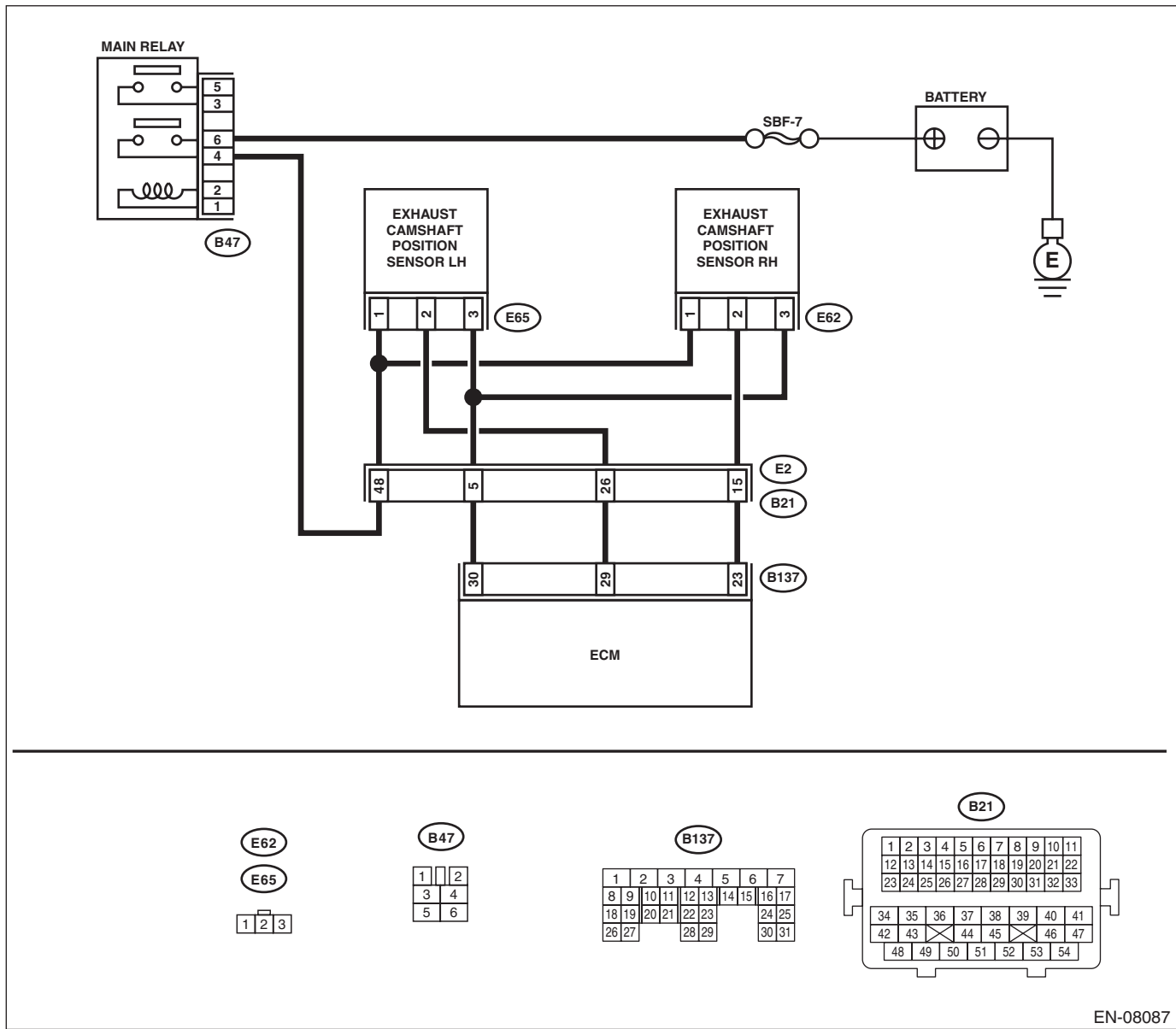

EN-08087

# Diagnostic Procedure with Diagnostic Trouble Code (DTC)

ENGINE (DIAGNOSTICS)

Step	Check	Yes	No
<b>1 CHECK POWER SUPPLY OF CAMSHAFT POSITION SENSOR.</b> 1) Turn the ignition switch to OFF. 2) Disconnect the connector from camshaft position sensor. 3) Turn the ignition switch to ON. 4) Measure the voltage between camshaft position sensor connector and engine ground. <b>Connector &amp; terminal</b> <b>(E62) No. 1 (+) — Engine ground (-):</b>	Is the voltage 10 V or more?	Go to step 2.	Repair the harness and connector. NOTE: In this case, repair the following item: • Open circuit or short circuit to ground in harness between main relay connector and camshaft position sensor connector • Poor contact of coupling connector
<b>2 CHECK HARNESS BETWEEN ECM AND CAMSHAFT POSITION SENSOR CONNECTOR.</b> 1) Turn the ignition switch to OFF. 2) Disconnect the connector from ECM. 3) Measure the resistance between ECM and camshaft position sensor connector. <b>Connector &amp; terminal</b> <b>(B137) No. 23 — (E62) No. 2:</b> <b>(B137) No. 30 — (E62) No. 3:</b>	Is the resistance less than 1 Ω?	Go to step 3.	Repair the harness and connector. NOTE: In this case, repair the following item: • Open circuit in harness between ECM and camshaft position sensor connector • Poor contact of coupling connector
<b>3 CHECK HARNESS BETWEEN ECM AND CAMSHAFT POSITION SENSOR CONNECTOR.</b> Measure the resistance between camshaft position sensor connector and engine ground. <b>Connector &amp; terminal</b> <b>(E62) No. 2 — Engine ground:</b>	Is the resistance 1 MΩ or more?	Go to step 4.	Repair short circuit to ground in harness between ECM and camshaft position sensor connector.
<b>4 CHECK HARNESS BETWEEN ECM AND CAMSHAFT POSITION SENSOR CONNECTOR.</b> Measure the voltage between camshaft position sensor connector and engine ground. <b>Connector &amp; terminal</b> <b>(E62) No. 2 (+) — Engine ground (-):</b>	Is the voltage 5 V or more?	Repair the short circuit to power in the harness between ECM and camshaft position sensor connector.	Go to step 5.
<b>5 CHECK CONDITION OF CAMSHAFT POSITION SENSOR.</b>	Is the camshaft position sensor installation bolt tightened securely?	Go to step 6.	Tighten the camshaft position sensor installation bolt securely.
<b>6 CHECK CAMSHAFT POSITION SENSOR.</b> Check the waveform of the camshaft position sensor. <Ref. to EN(H6DO)(diag)-18, Engine Control Module (ECM) I/O Signal.>	Is there any abnormality in waveform?	Replace the camshaft position sensor. <Ref. to FU(H6DO)-34, Camshaft Position Sensor.>	Repair the following item. • Poor contact of ECM connector • Poor contact of camshaft position sensor connector • Poor contact of coupling connector

## **Diagnostic Procedure with Diagnostic Trouble Code (DTC)**

ENGINE (DIAGNOSTICS)

---

### **DA:DTC P0366 CAMSHAFT POSITION SENSOR B CIRCUIT RANGE/PERFORMANCE (BANK 1)**

**NOTE:**

For the diagnostic procedure, refer to DTC P0365. <Ref. to EN(H6DO)(diag)-232, DTC P0365 CAMSHAFT POSITION SENSOR "B" CIRCUIT (BANK 1), Diagnostic Procedure with Diagnostic Trouble Code (DTC).>



# Diagnostic Procedure with Diagnostic Trouble Code (DTC)

ENGINE (DIAGNOSTICS)

## DB:DTC P0390 CAMSHAFT POSITION SENSOR "B" CIRCUIT (BANK 2)

### DTC DETECTING CONDITION:

- Immediately at fault recognition
- GENERAL DESCRIPTION <Ref. to GD(H6DO)-135, DTC P0390 CAMSHAFT POSITION SENSOR "B" CIRCUIT (BANK 2), Diagnostic Trouble Code (DTC) Detecting Criteria.>

### TROUBLE SYMPTOM:

- Engine stalls.
- Failure of engine to start

### CAUTION:

After servicing or replacing faulty parts, perform Clear Memory Mode <Ref. to EN(H6DO)(diag)-62, OPERATION, Clear Memory Mode.>, and Inspection Mode <Ref. to EN(H6DO)(diag)-47, PROCEDURE, Inspection Mode.>.

### WIRING DIAGRAM:

Engine electrical system <Ref. to WI-32, Engine Electrical System.>

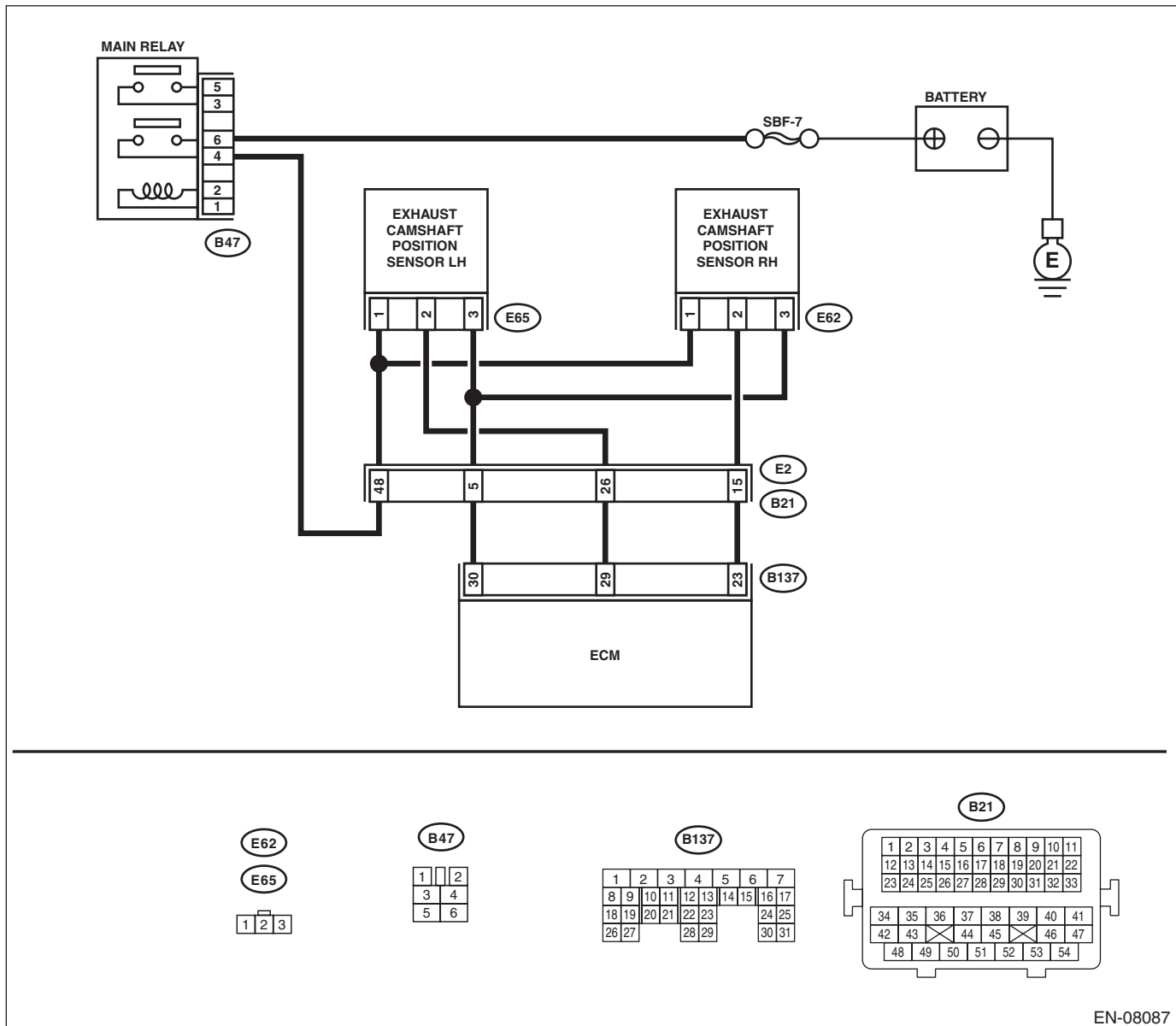

EN-08087

# Diagnostic Procedure with Diagnostic Trouble Code (DTC)

## ENGINE (DIAGNOSTICS)

	Step	Check	Yes	No
1	<p><b>CHECK POWER SUPPLY OF CAMSHAFT POSITION SENSOR.</b></p> <p>1) Turn the ignition switch to OFF.            2) Disconnect the connector from camshaft position sensor.            3) Turn the ignition switch to ON.            4) Measure the voltage between camshaft position sensor connector and engine ground.</p> <p><b>Connector &amp; terminal</b>  <b>(E65) No. 1 (+) — Engine ground (-):</b></p>	Is the voltage 10 V or more?	Go to step 2.	Repair the harness and connector.  <b>NOTE:</b> In this case, repair the following item: • Open circuit or short circuit to ground in harness between main relay connector and camshaft position sensor connector • Poor contact of coupling connector
2	<p><b>CHECK HARNESS BETWEEN ECM AND CAMSHAFT POSITION SENSOR CONNECTOR.</b></p> <p>1) Turn the ignition switch to OFF.            2) Disconnect the connector from ECM.            3) Measure the resistance between ECM and camshaft position sensor connector.</p> <p><b>Connector &amp; terminal</b>  <b>(B137) No. 29 — (E65) No. 2:</b>  <b>(B137) No. 30 — (E65) No. 3:</b></p>	Is the resistance less than 1 $\Omega$ ?	Go to step 3.	Repair the harness and connector.  <b>NOTE:</b> In this case, repair the following item: • Open circuit in harness between ECM and camshaft position sensor connector • Poor contact of coupling connector
3	<p><b>CHECK HARNESS BETWEEN ECM AND CAMSHAFT POSITION SENSOR CONNECTOR.</b></p> <p>Measure the resistance between camshaft position sensor connector and engine ground.</p> <p><b>Connector &amp; terminal</b>  <b>(E65) No. 2 — Engine ground:</b></p>	Is the resistance 1 M $\Omega$ or more?	Go to step 4.	Repair short circuit to ground in harness between ECM and camshaft position sensor connector.
4	<p><b>CHECK HARNESS BETWEEN ECM AND CAMSHAFT POSITION SENSOR CONNECTOR.</b></p> <p>Measure the voltage between camshaft position sensor connector and engine ground.</p> <p><b>Connector &amp; terminal</b>  <b>(E65) No. 2 (+) — Engine ground (-):</b></p>	Is the voltage 5 V or more?	Repair the short circuit to power in the harness between ECM and camshaft position sensor connector.	Go to step 5.
5	<p><b>CHECK CONDITION OF CAMSHAFT POSITION SENSOR.</b></p>	Is the camshaft position sensor installation bolt tightened securely?	Go to step 6.	Tighten the camshaft position sensor installation bolt securely.
6	<p><b>CHECK CAMSHAFT POSITION SENSOR.</b></p> <p>Check the waveform of the camshaft position sensor. &lt;Ref. to EN(H6DO)(diag)-18, Engine Control Module (ECM) I/O Signal.&gt;</p>	Is there any abnormality in waveform?	Replace the camshaft position sensor. <Ref. to FU(H6DO)-34, Camshaft Position Sensor.>	Repair the following item. • Poor contact of ECM connector • Poor contact of camshaft position sensor connector • Poor contact of coupling connector

## Diagnostic Procedure with Diagnostic Trouble Code (DTC)

ENGINE (DIAGNOSTICS)

---

### **DC:DTC P0391 CAMSHAFT POSITION SENSOR B CIRCUIT RANGE/PERFORMANCE (BANK 2)**

**NOTE:**

For the diagnostic procedure, refer to DTC P0390. <Ref. to EN(H6DO)(diag)-235, DTC P0390 CAMSHAFT POSITION SENSOR "B" CIRCUIT (BANK 2), Diagnostic Procedure with Diagnostic Trouble Code (DTC).>

# Diagnostic Procedure with Diagnostic Trouble Code (DTC)

ENGINE (DIAGNOSTICS)

## DD:DTC P0400 EXHAUST GAS RECIRCULATION FLOW

### DTC DETECTING CONDITION:

- Detected when two consecutive driving cycles with fault occur.
- GENERAL DESCRIPTION <Ref. to GD(H6DO)-136, DTC P0400 EXHAUST GAS RECIRCULATION FLOW, Diagnostic Trouble Code (DTC) Detecting Criteria.>

### TROUBLE SYMPTOM:

- Movement performance problem when engine is low speed.
- Improper idling
- Movement performance problem

### CAUTION:

After servicing or replacing faulty parts, perform Clear Memory Mode <Ref. to EN(H6DO)(diag)-62, OPERATION, Clear Memory Mode.>, and Inspection Mode <Ref. to EN(H6DO)(diag)-47, PROCEDURE, Inspection Mode.>.

	Step	Check	Yes	No
1	<b>CHECK CURRENT DATA.</b> 1) Start the engine. 2) Read the value of «Mani. Absolute Pressure» using the Subaru Select Monitor or a general scan tool. <b>NOTE:</b> <ul style="list-style-type: none"><li>• Subaru Select Monitor</li></ul> For detailed operation procedures, refer to “READ CURRENT DATA FOR ENGINE”. <Ref. to EN(H6DO)(diag)-37, Subaru Select Monitor.> <ul style="list-style-type: none"><li>• General scan tool</li></ul> For detailed operation procedures, refer to the general scan tool operation manual.	Is the value of «Mani. Absolute Pressure» 53.3 kPa (400 mmHg, 15.75 inHg) or more?	Make sure that the EGR control valve, manifold absolute pressure sensor and throttle body are installed securely.	Go to step 2.
2	<b>CHECK EGR CONTROL VALVE.</b> Remove the EGR control valve.	Are there any holes, clogged lines or foreign matters in the EGR system?	Repair the EGR system.	Replace EGR control valve. <Ref. to FU(H6DO)-41, EGR Valve.>

# Diagnostic Procedure with Diagnostic Trouble Code (DTC)

ENGINE (DIAGNOSTICS)

## DE:DTC P0420 CATALYST SYSTEM EFFICIENCY BELOW THRESHOLD (BANK 1)

### DTC DETECTING CONDITION:

- Detected when two consecutive driving cycles with fault occur.
- GENERAL DESCRIPTION <Ref. to GD(H6DO)-139, DTC P0420 CATALYST SYSTEM EFFICIENCY BELOW THRESHOLD (BANK 1), Diagnostic Trouble Code (DTC) Detecting Criteria.>

### TROUBLE SYMPTOM:

- Engine stalls.
- Idle mixture is out of specifications.

### CAUTION:

After servicing or replacing faulty parts, perform Clear Memory Mode <Ref. to EN(H6DO)(diag)-62, OPERATION, Clear Memory Mode.>, and Inspection Mode <Ref. to EN(H6DO)(diag)-47, PROCEDURE, Inspection Mode.>.

### WIRING DIAGRAM:

Engine electrical system <Ref. to WI-32, Engine Electrical System.>

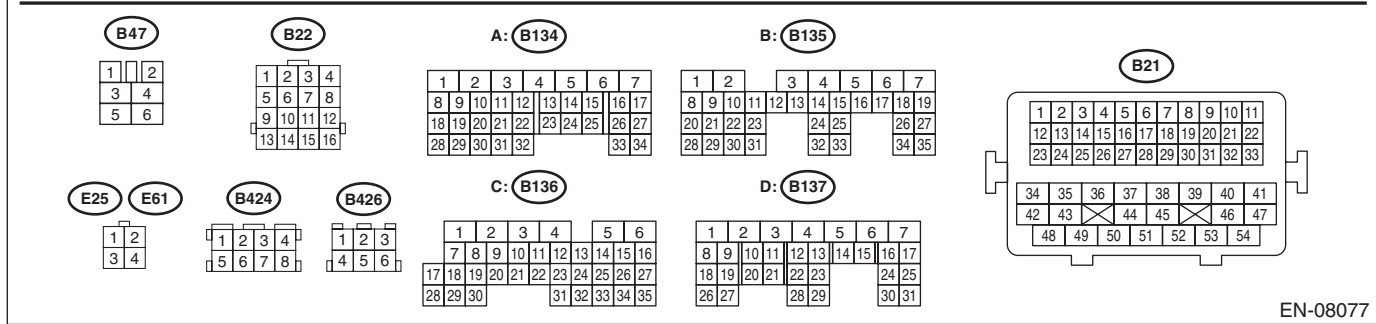
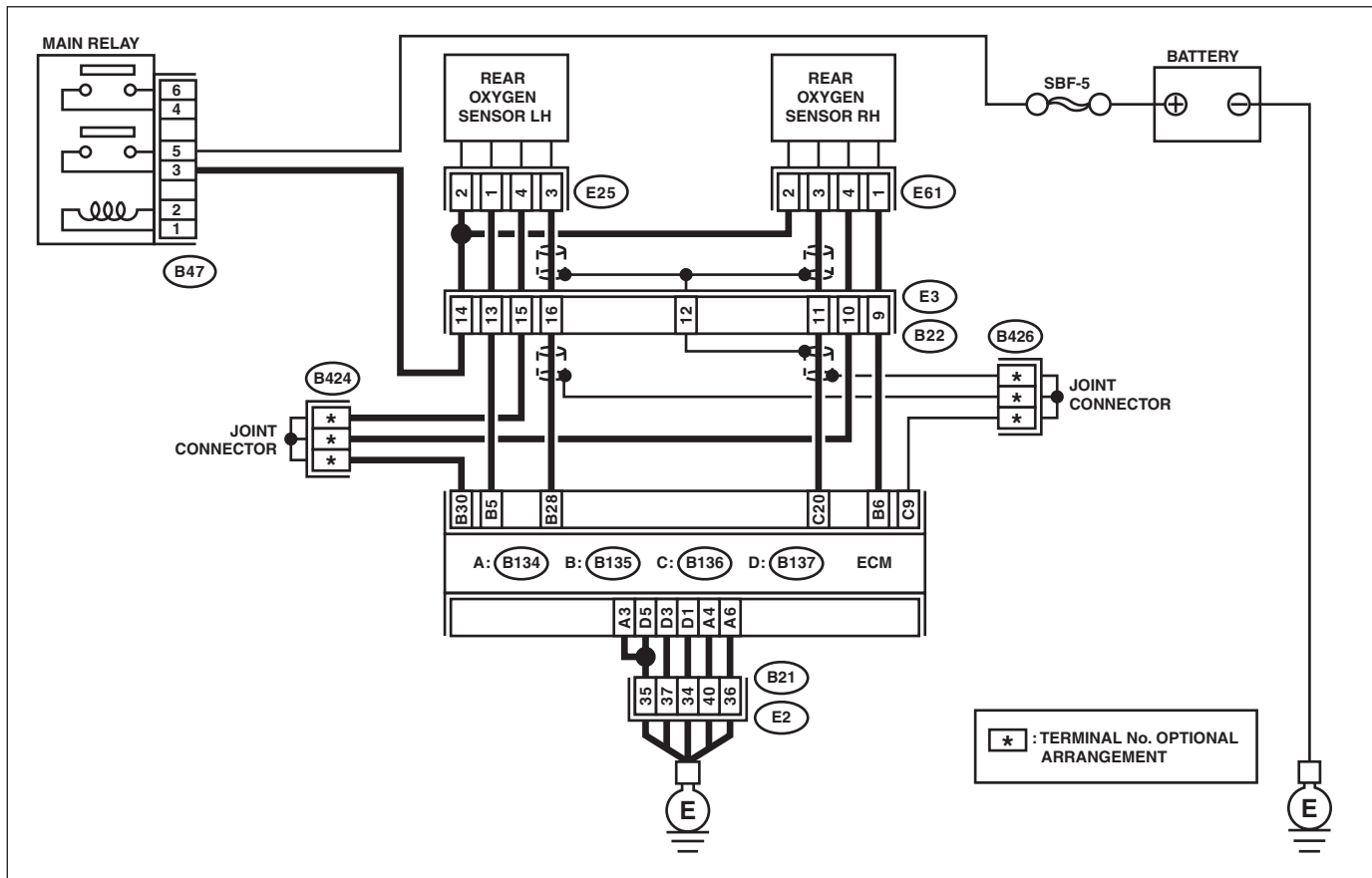

EN-08077

# Diagnostic Procedure with Diagnostic Trouble Code (DTC)

## ENGINE (DIAGNOSTICS)

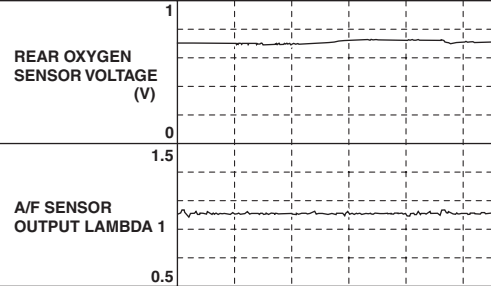
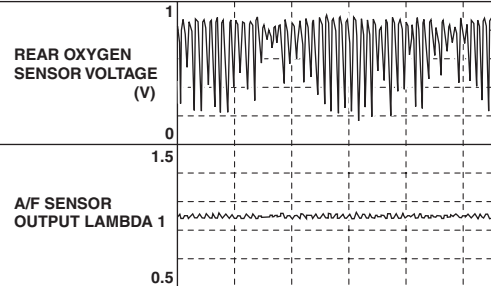
Step	Check	Yes	No
<p><b>1</b></p> <p><b>CHECK EXHAUST SYSTEM.</b> Check for gas leaks or air suction caused by loose or dislocated nuts and bolts, and open hole at exhaust pipes.</p> <p>NOTE: Check the following positions.</p> <ul style="list-style-type: none"> <li>• Between cylinder head and front exhaust pipe</li> <li>• Between front exhaust pipe and front catalytic converter</li> <li>• Between front catalytic converter and rear catalytic converter</li> <li>• Loose or improperly attached front oxygen (A/F) sensor or rear oxygen sensor</li> </ul>	<p>Is there any fault in exhaust system?</p>	<p>Repair or replace the exhaust system. &lt;Ref. to EX(H6DO)-2, General Description.&gt;</p>	<p>Go to step 2.</p>
<p><b>2</b></p> <p><b>CHECK WAVEFORM DATA ON THE SUBARU SELECT MONITOR (WHILE DRIVING).</b></p> <p>1) Drive at a constant speed between 80 — 112 km/h (50 — 70 MPH).</p> <p>2) After 5 minutes have elapsed in the condition of step 1), use the Subaru Select Monitor while still driving to read the waveform data.</p> <ul style="list-style-type: none"> <li>• At normal condition</li> </ul>  <p>10 sec/div EN-06666</p> <ul style="list-style-type: none"> <li>• At abnormal condition (numerous inversion)</li> </ul>  <p>10 sec/div EN-06667</p>	<p>Is a normal waveform displayed?</p>	<p>Even if DTC is detected, the circuit has returned to a normal condition at this time. Reproduce the failure, and then perform the diagnosis again.</p> <p>NOTE: In this case, temporary poor contact of connector, temporary open or short circuit of harness may be the cause.</p>	<p>Go to step 3.</p>

# Diagnostic Procedure with Diagnostic Trouble Code (DTC)

ENGINE (DIAGNOSTICS)

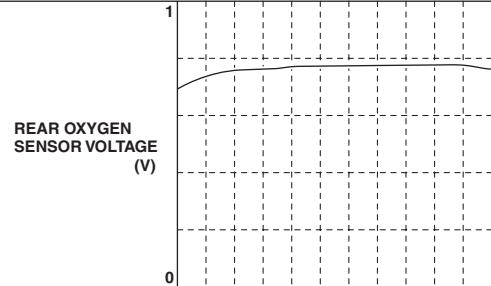
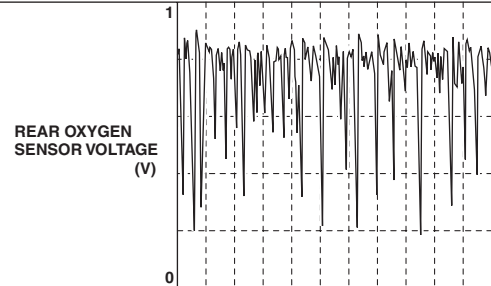
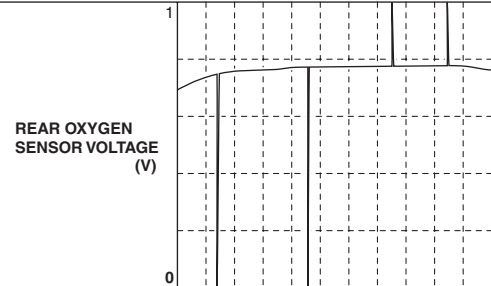
Step	Check	Yes	No
<p><b>3</b>      <b>CHECK WAVEFORM DATA ON THE SUBARU SELECT MONITOR (WHILE IDLING).</b></p> <p>1) Run the engine at idle. 2) In the condition of step 1), use the Subaru Select Monitor to read the waveform data.</p> <ul style="list-style-type: none"> <li>• At normal condition</li> </ul>  <p>10 sec/div      EN-06668</p> <ul style="list-style-type: none"> <li>• At abnormal condition 1 (numerous inversion)</li> </ul>  <p>10 sec/div      EN-06669</p> <ul style="list-style-type: none"> <li>• At abnormal condition 2 (noise input)</li> </ul>  <p>10 sec/div      EN-06670</p>	<p>Is a normal waveform displayed?</p>	<p>Go to step 4.</p>	<ul style="list-style-type: none"> <li>• The waveform is displayed at abnormal condition 1: Go to step 4.</li> <li>• The waveform is displayed at abnormal condition 2: Go to step 5.</li> </ul>
<p><b>4</b>      <b>CHECK CATALYTIC CONVERTER.</b></p>	<p>Is the catalytic converter damaged?</p>	<p>Replace the catalytic converter. &lt;Ref. to EC(H6DO)-3, Front Catalytic Converter.&gt;</p>	<p>Go to step 5.</p>
<p><b>5</b>      <b>CHECK REAR OXYGEN SENSOR CONNECTOR AND COUPLING CONNECTOR.</b></p>	<p>Has water entered the connector?</p>	<p>Completely remove any water inside.</p>	<p>Go to step 6.</p>

# Diagnostic Procedure with Diagnostic Trouble Code (DTC)

## ENGINE (DIAGNOSTICS)

Step	Check	Yes	No
<b>6 CHECK HARNESS BETWEEN ECM AND REAR OXYGEN SENSOR CONNECTOR.</b> 1) Turn the ignition switch to OFF. 2) Disconnect the connector from ECM and rear oxygen sensor. 3) Measure the resistance of harness between ECM and rear oxygen sensor connector. <b>Connector &amp; terminal</b> <b>(B136) No. 20 — (E61) No. 3:</b> <b>(B135) No. 30 — (E61) No. 4:</b> <b>(B135) No. 28 — (E25) No. 3:</b> <b>(B135) No. 30 — (E25) No. 4:</b>	Is the resistance less than 1 $\Omega$ ?	Go to step 7.	Repair the harness and connector.  NOTE: In this case, repair the following item: <ul style="list-style-type: none"> <li>• Open circuit in harness between ECM and rear oxygen sensor connector</li> <li>• Poor contact of coupling connector</li> </ul>
<b>7 CHECK REAR OXYGEN SENSOR SHIELD.</b> 1) Turn the ignition switch to OFF. 2) Expose the rear oxygen sensor connector body side harness sensor shield. 3) Measure the resistance between sensor shield and chassis ground.	Is the resistance less than 1 $\Omega$ ?	Go to step 8.	Repair the open circuit of rear oxygen sensor harness.
<b>8 CHECK ENGINE OIL AMOUNT AND EXHAUST GAS.</b> 1) Check the engine oil amount. <Ref. to LU(H6DO)-10, INSPECTION, Engine Oil.> 2) Check exhaust gas during idling.	Does the engine oil amount drop or white smoke emit from the muffler?	Check the engine, and repair the defective part. <Ref. to ME(H6DO)-125, INSPECTION, Engine Trouble in General.> After repairing the engine, replace the catalytic converter. <Ref. to EX(H6DO)-4, Front Exhaust Pipe.> After the catalytic converter is replaced, perform step 2 to check the normal waveform is displayed, and then exit the procedure.	Go to step 9.
<b>9 CHECK IGNITION SYSTEM.</b> 1) Check the spark plug. <Ref. to IG(H6DO)-5, INSPECTION, Spark Plug.> 2) Check the status of the ignition coil connector and the spark plug terminal.	Is there any fault in the ignition system?	After repairing the ignition system, replace the catalytic converter. <Ref. to EX(H6DO)-4, Front Exhaust Pipe.> After the catalytic converter is replaced, perform step 2 to check the normal waveform is displayed, and then exit the procedure.	Go to step 10.



# Diagnostic Procedure with Diagnostic Trouble Code (DTC)

ENGINE (DIAGNOSTICS)

Step	Check	Yes	No
<p><b>10</b>      <b>CHECK FUEL SYSTEM.</b>                      1) Refer to and check the items in "Insufficient fuel supply to fuel injector (except for "a. Fuel pump does not operate.")" and "Leakage or blow out of fuel". &lt;Ref. to FU(H6DO)-78, INSPECTION, Fuel System Trouble in General.&gt;                      2) Check throttle body. &lt;Ref. to FU(H6DO)-20, INSPECTION, Throttle Body.&gt;                      3) Check intake manifold. &lt;Ref. to FU(H6DO)-29, INSPECTION, Intake Manifold.&gt;</p>	<p>Is there any fault in the fuel system?</p>	<p>After repairing the fuel system, replace the catalytic converter. &lt;Ref. to EX(H6DO)-4, Front Exhaust Pipe.&gt;                      After the catalytic converter is replaced, perform step 2 to check the normal waveform is displayed, and then exit the procedure.</p>	<p>Go to step 11.</p>
<p><b>11</b>      <b>CHECK DTC.</b></p>	<p>Is any other DTC displayed?</p>	<p>Check the appropriate DTC using the "List of Diagnostic Trouble Code (DTC)". &lt;Ref. to EN(H6DO)(diag)-89, List of Diagnostic Trouble Code (DTC).&gt;                      After checking the DTC, replace the catalytic converter. &lt;Ref. to EX(H6DO)-4, Front Exhaust Pipe.&gt;                      After the catalytic converter is replaced, perform step 2 to check the normal waveform is displayed, and then exit the procedure.</p>	<p>Replace the rear oxygen sensor. &lt;Ref. to FU(H6DO)-50, Rear Oxygen Sensor.&gt;</p>

# Diagnostic Procedure with Diagnostic Trouble Code (DTC)

ENGINE (DIAGNOSTICS)

## DF:DTC P0441 EVAPORATIVE EMISSION CONT. SYS. INCORRECT PURGE FLOW

### DTC DETECTING CONDITION:

- Detected when two consecutive driving cycles with fault occur.
- GENERAL DESCRIPTION <Ref. to GD(H6DO)-141, DTC P0441 EVAPORATIVE EMISSION CONT. SYS. INCORRECT PURGE FLOW, Diagnostic Trouble Code (DTC) Detecting Criteria.>

### TROUBLE SYMPTOM:

Improper idling

### CAUTION:

After servicing or replacing faulty parts, perform Clear Memory Mode <Ref. to EN(H6DO)(diag)-62, OPERATION, Clear Memory Mode.>, and Inspection Mode <Ref. to EN(H6DO)(diag)-47, PROCEDURE, Inspection Mode.>.

Step	Check	Yes	No
<b>1</b> <b>CHECK FOR ANY OTHER DTC ON DISPLAY.</b>	Is any other DTC displayed?	Check the appropriate DTC using the "List of Diagnostic Trouble Code (DTC)". <Ref. to EN(H6DO)(diag)-89, List of Diagnostic Trouble Code (DTC).>	Go to step 2.
<b>2</b> <b>CHECK PURGE CONTROL SOLENOID VALVE.</b> Operate the purge control solenoid valve using the Subaru Select Monitor. NOTE: For detailed procedures, refer to "System Operation Check Mode". <Ref. to EN(H6DO)(diag)-64, System Operation Check Mode.>	Does the purge control solenoid valve operate?	Go to step 3.	Replace the purge control solenoid valve. <Ref. to EC(H6DO)-7, Purge Control Solenoid Valve.>
<b>3</b> <b>CHECK EVAPORATIVE EMISSION CONTROL SYSTEM LINE.</b> 1) Turn the ignition switch to OFF. 2) Check the delivery (test) mode connector is disconnected.	Are there holes, cracks, clogging, or disconnection, misconnection of hoses or pipes in evaporative emission control system?	Repair or replace the hoses or pipes.	Repair the poor contact of ECM connector.

# Diagnostic Procedure with Diagnostic Trouble Code (DTC)

ENGINE (DIAGNOSTICS)

## DG:DTC P0451 EVAPORATIVE EMISSION SYSTEM PRESSURE SENSOR/ SWITCH RANGE/PERFORMANCE

### DTC DETECTING CONDITION:

- Detected when two consecutive driving cycles with fault occur.
- GENERAL DESCRIPTION <Ref. to GD(H6DO)-144, DTC P0451 EVAPORATIVE EMISSION SYSTEM PRESSURE SENSOR/SWITCH RANGE/PERFORMANCE, Diagnostic Trouble Code (DTC) Detecting Criteria.>

### CAUTION:

After servicing or replacing faulty parts, perform Clear Memory Mode <Ref. to EN(H6DO)(diag)-62, OPERATION, Clear Memory Mode.>, and Inspection Mode <Ref. to EN(H6DO)(diag)-47, PROCEDURE, Inspection Mode.>.

Step	Check	Yes	No
1 <b>CHECK FOR ANY OTHER DTC ON DISPLAY.</b>	Is any other DTC displayed?	Check the appropriate DTC using the "List of Diagnostic Trouble Code (DTC)". <Ref. to EN(H6DO)(diag)-89, List of Diagnostic Trouble Code (DTC).>	Go to step 2.
2 <b>CHECK CURRENT DATA.</b> 1) Turn the ignition switch to ON (engine OFF). 2) Using the Subaru Select Monitor or general scan tool, read the value in «Atmosphere Pressure» and «Mani. Absolute Pressure», and compare them with the actual atmospheric pressure. <b>NOTE:</b> • Subaru Select Monitor For detailed operation procedures, refer to "READ CURRENT DATA FOR ENGINE". <Ref. to EN(H6DO)(diag)-37, Subaru Select Monitor.> • General scan tool For detailed operation procedures, refer to the general scan tool operation manual. • To read the actual atmospheric pressure, connect the Subaru Select Monitor or general scan tool to the other known good vehicle.	Is the difference with the actual atmospheric pressure 27 kPa (200 mmHg, 7.9 inHg) or more?	Replace the parts that showed deviations from the actual atmospheric pressure. • If deviations are found in value for «Atmosphere Pressure»: Replace the leak check valve assembly. <Ref. to EC(H6DO)-12, Leak Check Valve Assembly.> • If deviations are found in value for «Mani. Absolute Pressure»: Replace the manifold pressure sensor. <Ref. to FU(H6DO)-39, Manifold Absolute Pressure Sensor.>	Even if DTC is detected, the circuit has returned to a normal condition at this time. Reproduce the failure, and then perform the diagnosis again. <b>NOTE:</b> In this case, temporary poor contact of connector, temporary open or short circuit of harness may be the cause.

# Diagnostic Procedure with Diagnostic Trouble Code (DTC)

ENGINE (DIAGNOSTICS)

## DH:DTC P0452 EVAPORATIVE EMISSION SYSTEM PRESSURE SENSOR/ SWITCH LOW

### DTC DETECTING CONDITION:

- Immediately at fault recognition
- GENERAL DESCRIPTION <Ref. to GD(H6DO)-146, DTC P0452 EVAPORATIVE EMISSION SYSTEM PRESSURE SENSOR/SWITCH LOW, Diagnostic Trouble Code (DTC) Detecting Criteria.>

### CAUTION:

After servicing or replacing faulty parts, perform Clear Memory Mode <Ref. to EN(H6DO)(diag)-62, OPERATION, Clear Memory Mode.>, and Inspection Mode <Ref. to EN(H6DO)(diag)-47, PROCEDURE, Inspection Mode.>.

### WIRING DIAGRAM:

Engine electrical system <Ref. to WI-32, Engine Electrical System.>

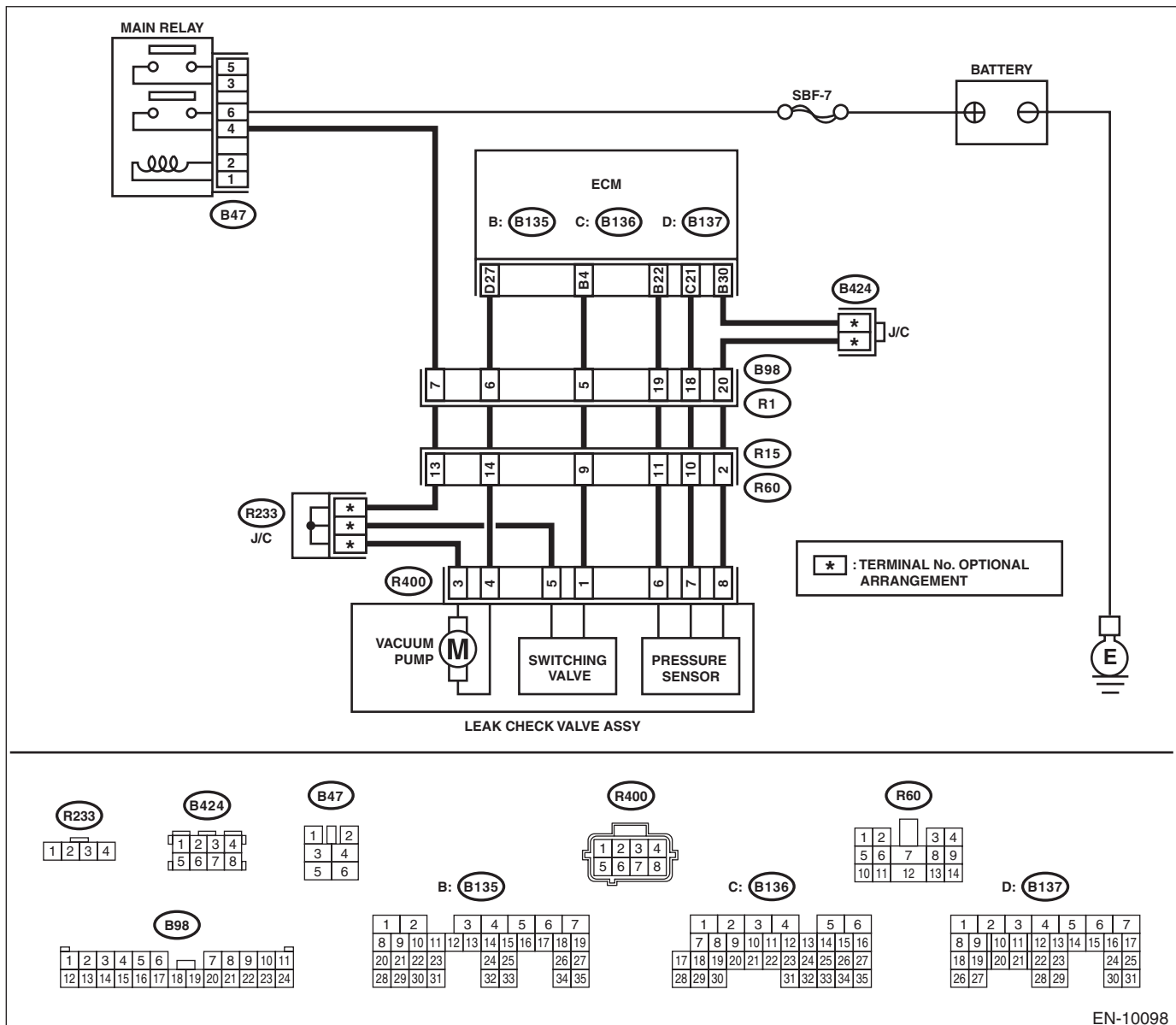

EN-10098

# Diagnostic Procedure with Diagnostic Trouble Code (DTC)

ENGINE (DIAGNOSTICS)

	Step	Check	Yes	No
1	<p><b>CHECK CURRENT DATA.</b></p> <p>1) Turn the ignition switch to ON.</p> <p>2) Read the value of «Atmosphere Pressure» using the Subaru Select Monitor or a general scan tool.</p> <p>NOTE:</p> <ul style="list-style-type: none"> <li>• Subaru Select Monitor</li> </ul> <p>For detailed operation procedures, refer to “READ CURRENT DATA FOR ENGINE”. &lt;Ref. to EN(H6DO)(diag)-37, Subaru Select Monitor.&gt;</p> <ul style="list-style-type: none"> <li>• General scan tool</li> </ul> <p>For detailed operation procedures, refer to the general scan tool operation manual.</p>	<p>Is the value in «Atmosphere Pressure» 34 kPa (255 mmHg, 10 inHg) or less?</p>	<p>Go to step 2.</p>	<p>Even if DTC is detected, the circuit has returned to a normal condition at this time. Reproduce the failure, and then perform the diagnosis again.</p> <p>NOTE:</p> <p>In this case, temporary poor contact of connector, temporary open or short circuit of harness may be the cause.</p>
2	<p><b>CHECK POWER SUPPLY OF LEAK CHECK VALVE ASSEMBLY.</b></p> <p>1) Turn the ignition switch to OFF.</p> <p>2) Disconnect the connector from the leak check valve assembly.</p> <p>3) Turn the ignition switch to ON.</p> <p>4) Measure the voltage between the leak check valve assembly connector and chassis ground.</p> <p><b>Connector &amp; terminal</b> <b>(R400) No. 6 (+) — Chassis ground (-):</b></p>	<p>Is the voltage 4.5 V or more?</p>	<p>Go to step 3.</p>	<p>Repair the harness and connector.</p> <p>NOTE:</p> <p>In this case, repair the following item:</p> <ul style="list-style-type: none"> <li>• Open circuit in harness between ECM and the leak check valve assembly connector</li> <li>• Poor contact of ECM connector</li> <li>• Poor contact of coupling connector</li> </ul>
3	<p><b>CHECK HARNESS BETWEEN ECM AND LEAK CHECK VALVE ASSEMBLY CONNECTOR.</b></p> <p>1) Turn the ignition switch to OFF.</p> <p>2) Disconnect the connector from ECM.</p> <p>3) Measure the resistance between ECM and chassis ground.</p> <p><b>Connector &amp; terminal</b> <b>(B136) No. 21 — Chassis ground:</b></p>	<p>Is the resistance 1 MΩ or more?</p>	<p>Go to step 4.</p>	<p>Repair the short circuit to ground in harness between ECM and leak check valve assembly connector.</p>
4	<p><b>CHECK FOR POOR CONTACT.</b></p> <p>Check for poor contact of leak check valve assembly connector.</p>	<p>Is there poor contact in the leak check valve assembly connector?</p>	<p>Repair the poor contact in the leak check valve assembly connector.</p>	<p>Replace the leak check valve assembly. &lt;Ref. to EC(H6DO)-12, Leak Check Valve Assembly.&gt;</p>

# Diagnostic Procedure with Diagnostic Trouble Code (DTC)

ENGINE (DIAGNOSTICS)

## DI: DTC P0453 EVAPORATIVE EMISSION SYSTEM PRESSURE SENSOR/ SWITCH HIGH

### DTC DETECTING CONDITION:

- Immediately at fault recognition
- GENERAL DESCRIPTION <Ref. to GD(H6DO)-148, DTC P0453 EVAPORATIVE EMISSION SYSTEM PRESSURE SENSOR/SWITCH HIGH, Diagnostic Trouble Code (DTC) Detecting Criteria.>

### CAUTION:

After servicing or replacing faulty parts, perform Clear Memory Mode <Ref. to EN(H6DO)(diag)-62, OPERATION, Clear Memory Mode.>, and Inspection Mode <Ref. to EN(H6DO)(diag)-47, PROCEDURE, Inspection Mode.>.

### WIRING DIAGRAM:

Engine electrical system <Ref. to WI-32, Engine Electrical System.>

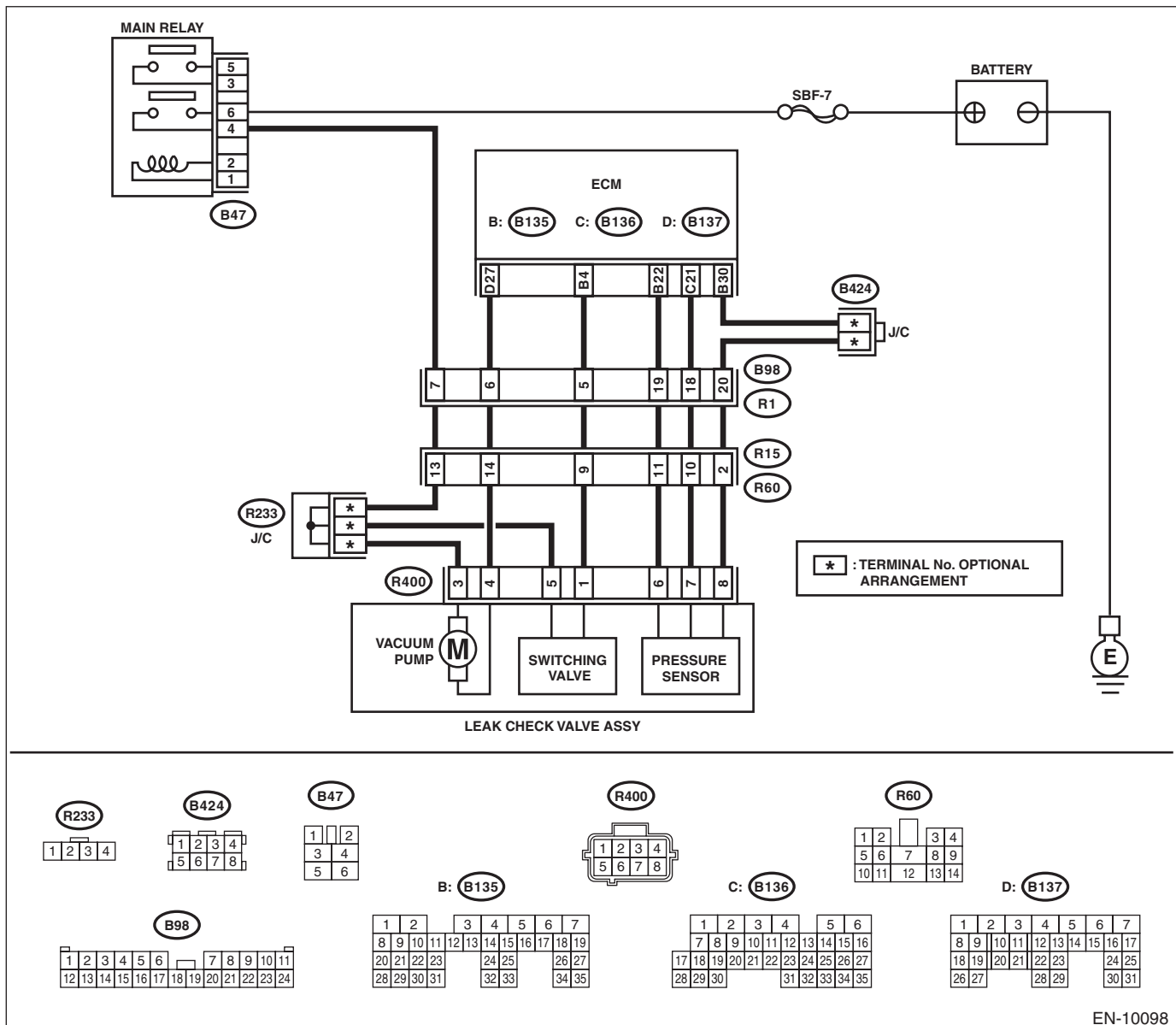

EN-10098

# Diagnostic Procedure with Diagnostic Trouble Code (DTC)

ENGINE (DIAGNOSTICS)

	Step	Check	Yes	No
1	<p><b>CHECK CURRENT DATA.</b></p> <p>1) Turn the ignition switch to ON.</p> <p>2) Read the value of «Atmosphere Pressure» using the Subaru Select Monitor or a general scan tool.</p> <p>NOTE:</p> <ul style="list-style-type: none"> <li>• Subaru Select Monitor</li> </ul> <p>For detailed operation procedures, refer to “READ CURRENT DATA FOR ENGINE”. &lt;Ref. to EN(H6DO)(diag)-37, Subaru Select Monitor.&gt;</p> <ul style="list-style-type: none"> <li>• General scan tool</li> </ul> <p>For detailed operation procedures, refer to the general scan tool operation manual.</p>	<p>Is the value in «Atmosphere Pressure» 125 kPa (938 mmHg, 36.9 inHg) or more?</p>	<p>Go to step 2.</p>	<p>Even if DTC is detected, the circuit has returned to a normal condition at this time. Reproduce the failure, and then perform the diagnosis again.</p> <p>NOTE:</p> <p>In this case, temporary poor contact of connector, temporary open or short circuit of harness may be the cause.</p>
2	<p><b>CHECK HARNESS BETWEEN ECM AND LEAK CHECK VALVE ASSEMBLY CONNECTOR.</b></p> <p>1) Turn the ignition switch to OFF.</p> <p>2) Disconnect the connector from ECM and the leak check valve assembly.</p> <p>3) Measure the resistance of harness between ECM and the leak check valve assembly connector.</p> <p><b>Connector &amp; terminal</b></p> <p><b>(B136) No. 21 — (R400) No. 7:</b></p> <p><b>(B135) No. 30 — (R400) No. 8:</b></p>	<p>Is the resistance less than 1 Ω?</p>	<p>Go to step 3.</p>	<p>Repair the harness and connector.</p> <p>NOTE:</p> <p>In this case, repair the following item:</p> <ul style="list-style-type: none"> <li>• Open circuit in harness between ECM and the leak check valve assembly connector</li> <li>• Poor contact of coupling connector</li> <li>• Poor contact of joint connector</li> </ul>
3	<p><b>CHECK FOR POOR CONTACT.</b></p> <p>Check for poor contact of ECM and the leak check valve assembly connector.</p>	<p>Is there poor contact in ECM and the leak check valve assembly connector?</p>	<p>Repair the poor contact of ECM and the leak check valve assembly connector.</p>	<p>Go to step 4.</p>
4	<p><b>CHECK LEAK CHECK VALVE ASSEMBLY.</b></p> <p>Check the pressure sensor of the leak check valve assembly. &lt;Ref. to EC(H6DO)-14, CHECK PRESSURE SENSOR, INSPECTION, Leak Check Valve Assembly.&gt;</p>	<p>Is the pressure sensor of the leak check valve assembly OK?</p>	<p>Repair the short circuit to power in harness between ECM and leak check valve assembly connector.</p>	<p>Replace the leak check valve assembly. &lt;Ref. to EC(H6DO)-12, Leak Check Valve Assembly.&gt;</p>

# Diagnostic Procedure with Diagnostic Trouble Code (DTC)

ENGINE (DIAGNOSTICS)

## DJ:DTC P0455 EVAPORATIVE EMISSION SYSTEM LEAK DETECTED (LARGE LEAK)

### DTC DETECTING CONDITION:

- Detected when two consecutive driving cycles with fault occur.
- GENERAL DESCRIPTION <Ref. to GD(H6DO)-150, DTC P0455 EVAPORATIVE EMISSION SYSTEM LEAK DETECTED (LARGE LEAK), Diagnostic Trouble Code (DTC) Detecting Criteria.>

### TROUBLE SYMPTOM:

- Fuel odor
- There is a hole of more than 1.0 mm (0.04 in) dia. in evaporation system or fuel tank.
- Fuel filler cap loose or lost

### CAUTION:

After servicing or replacing faulty parts, perform Clear Memory Mode <Ref. to EN(H6DO)(diag)-62, OPERATION, Clear Memory Mode.>, and Inspection Mode <Ref. to EN(H6DO)(diag)-47, PROCEDURE, Inspection Mode.>.

Step	Check	Yes	No
1 <b>CHECK FUEL FILLER CAP.</b> 1) Turn the ignition switch to OFF. 2) Check the fuel filler cap.  NOTE: The DTC is stored in memory if fuel filler cap is or was loose or if the cap chain has caught while tightening.	Is the fuel filler cap tightened securely?	Go to step 2.	Tighten fuel filler cap securely.
2 <b>CHECK FUEL FILLER CAP.</b>	Is the fuel filler cap genuine?	Go to step 3.	Replace with a genuine fuel filler cap.
3 <b>CHECK FUEL FILLER PIPE GASKET.</b>	Is there any damage to the seal between fuel filler cap and fuel filler pipe?	Repair or replace the fuel filler cap and fuel filler pipe. <Ref. to FU(H6DO)-63, Fuel Filler Pipe.>	Go to step 4.
4 <b>CHECK PURGE CONTROL SOLENOID VALVE.</b> Check air-tightness of the purge control solenoid valve. <Ref. to EC(H6DO)-8, INSPECTION, Purge Control Solenoid Valve.>	Is the purge control solenoid valve OK?	Go to step 5.	Replace the purge control solenoid valve. <Ref. to EC(H6DO)-7, Purge Control Solenoid Valve.>
5 <b>CHECK EVAPORATIVE EMISSION CONTROL SYSTEM LINE.</b>	Are there holes on the evaporation line?	Repair or replace the evaporation line. <Ref. to FU(H6DO)-74, Fuel Delivery and Evaporation Lines.>	Go to step 6.
6 <b>CHECK CANISTER.</b>	Are there holes on the canister?	Replace the canister. <Ref. to EC(H6DO)-6, Canister.>	Go to step 7.
7 <b>CHECK LEAK CHECK VALVE ASSEMBLY.</b>	Are there damage or holes on the leak check valve assembly?	Replace the leak check valve assembly. <Ref. to EC(H6DO)-12, Leak Check Valve Assembly.>	Go to step 8.



# Diagnostic Procedure with Diagnostic Trouble Code (DTC)

ENGINE (DIAGNOSTICS)

	Step	Check	Yes	No
8	<b>CHECK FUEL TANK.</b> Remove the fuel tank. <Ref. to FU(H6DO)-60, Fuel Tank.>	Are there damage or holes on the fuel tank?	Repair or replace the fuel tank. <Ref. to FU(H6DO)-60, Fuel Tank.>	Go to step 9.
9	<b>CHECK ANY OTHER MECHANICAL TROUBLE IN EVAPORATIVE EMISSION CONTROL SYSTEM.</b>	Are there holes, cracks, clogging, or disconnection, misconnection of hoses or pipes in evaporative emission control system?	Repair or replace the hoses or pipes.	Repair the poor contact of ECM connector.

## DK:DTC P0456 EVAPORATIVE EMISSION CONTROL SYSTEM LEAK DETECTED (VERY SMALL LEAK)

### NOTE:

For the diagnostic procedure, refer to DTC P0455. <Ref. to EN(H6DO)(diag)-250, DTC P0455 EVAPORATIVE EMISSION SYSTEM LEAK DETECTED (LARGE LEAK), Diagnostic Procedure with Diagnostic Trouble Code (DTC).>

# Diagnostic Procedure with Diagnostic Trouble Code (DTC)

ENGINE (DIAGNOSTICS)

## DL:DTC P0458 EVAPORATIVE EMISSION SYSTEM PURGE CONTROL VALVE CIRCUIT LOW

### DTC DETECTING CONDITION:

- Detected when two consecutive driving cycles with fault occur.
- GENERAL DESCRIPTION <Ref. to GD(H6DO)-157, DTC P0458 EVAPORATIVE EMISSION SYSTEM PURGE CONTROL VALVE CIRCUIT LOW, Diagnostic Trouble Code (DTC) Detecting Criteria.>

### TROUBLE SYMPTOM:

Improper idling

### CAUTION:

After servicing or replacing faulty parts, perform Clear Memory Mode <Ref. to EN(H6DO)(diag)-62, OPERATION, Clear Memory Mode.>, and Inspection Mode <Ref. to EN(H6DO)(diag)-47, PROCEDURE, Inspection Mode.>.

### WIRING DIAGRAM:

Engine electrical system <Ref. to WI-32, Engine Electrical System.>

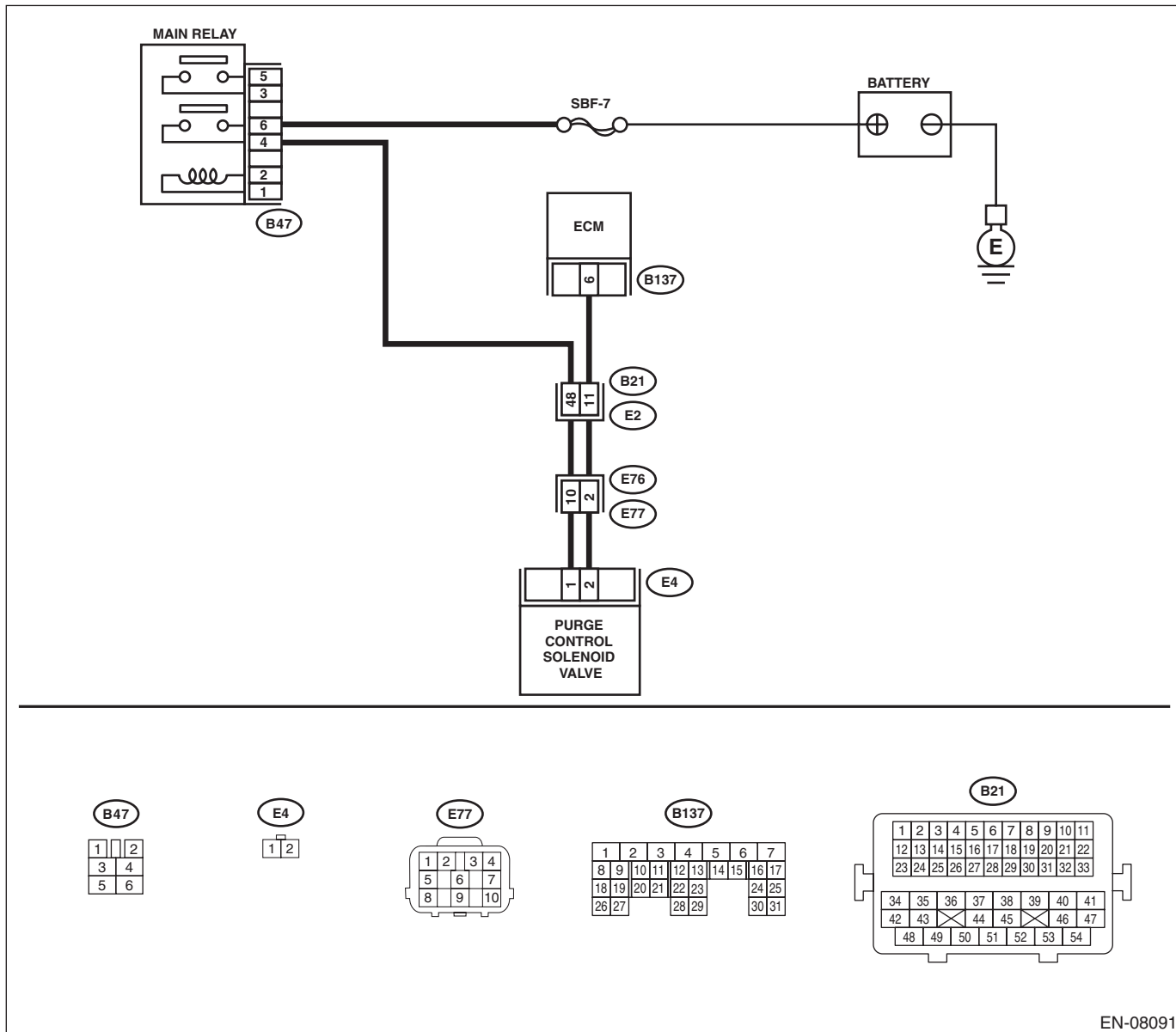

EN-08091

# Diagnostic Procedure with Diagnostic Trouble Code (DTC)

ENGINE (DIAGNOSTICS)

Step	Check	Yes	No
<b>1 CHECK OUTPUT SIGNAL OF ECM.</b> 1) Turn the ignition switch to ON. 2) Measure the voltage between ECM and chassis ground. <i>Connector &amp; terminal</i> <i>(B137) No. 6 (+) — Chassis ground (-):</i>	Is the voltage 10 V or more?	Go to step 2.	Go to step 3.
<b>2 CHECK FOR POOR CONTACT.</b> Check for poor contact of ECM connector.	Is there poor contact of ECM connector?	Repair the poor contact of ECM connector.	Even if DTC is detected, the circuit has returned to a normal condition at this time. Reproduce the failure, and then perform the diagnosis again.  NOTE: In this case, temporary open or short circuit of harness or temporary poor contact of connector may be the cause.
<b>3 CHECK POWER SUPPLY TO PURGE CONTROL SOLENOID VALVE.</b> Measure the voltage between purge control solenoid valve and engine ground. <i>Connector &amp; terminal</i> <i>(E4) No. 1 (+) — Engine ground (-):</i>	Is the voltage 10 V or more?	Go to step 4.	Repair the power supply circuit.
<b>4 CHECK HARNESS BETWEEN ECM AND PURGE CONTROL SOLENOID VALVE CONNECTOR.</b> 1) Turn the ignition switch to OFF. 2) Disconnect the connectors from ECM and purge control solenoid valve. 3) Measure the resistance between the purge control solenoid valve connector and engine ground. <i>Connector &amp; terminal</i> <i>(E4) No. 2 — Engine ground:</i>	Is the resistance 1 M $\Omega$ or more?	Go to step 5.	Repair the ground short circuit of harness between ECM and purge control solenoid valve connector.
<b>5 CHECK HARNESS BETWEEN ECM AND PURGE CONTROL SOLENOID VALVE CONNECTOR.</b> Measure the resistance of harness between ECM and purge control solenoid valve. <i>Connector &amp; terminal</i> <i>(B137) No. 6 — (E4) No. 2:</i>	Is the resistance less than 1 $\Omega$ ?	Go to step 6.	Repair the harness and connector.  NOTE: In this case, repair the following item: <ul style="list-style-type: none"> <li>• Open circuit in harness between ECM and purge control solenoid valve connector</li> <li>• Poor contact of coupling connector</li> </ul>
<b>6 CHECK PURGE CONTROL SOLENOID VALVE.</b> 1) Remove the purge control solenoid valve. 2) Measure the resistance between purge control solenoid valve terminals. <i>Terminals</i> <i>No. 1 — No. 2:</i>	Is the resistance 10 — 100 $\Omega$ ?	Repair the poor contact of purge control solenoid valve connector.	Replace the purge control solenoid valve. <Ref. to EC(H6DO)-7, Purge Control Solenoid Valve.>

# Diagnostic Procedure with Diagnostic Trouble Code (DTC)

ENGINE (DIAGNOSTICS)

## DM:DTC P0459 EVAPORATIVE EMISSION SYSTEM PURGE CONTROL VALVE CIRCUIT HIGH

### DTC DETECTING CONDITION:

- Detected when two consecutive driving cycles with fault occur.
- GENERAL DESCRIPTION <Ref. to GD(H6DO)-159, DTC P0459 EVAPORATIVE EMISSION SYSTEM PURGE CONTROL VALVE CIRCUIT HIGH, Diagnostic Trouble Code (DTC) Detecting Criteria.>

### TROUBLE SYMPTOM:

Improper idling

### CAUTION:

After servicing or replacing faulty parts, perform Clear Memory Mode <Ref. to EN(H6DO)(diag)-62, OPERATION, Clear Memory Mode.>, and Inspection Mode <Ref. to EN(H6DO)(diag)-47, PROCEDURE, Inspection Mode.>.

### WIRING DIAGRAM:

Engine electrical system <Ref. to WI-32, Engine Electrical System.>

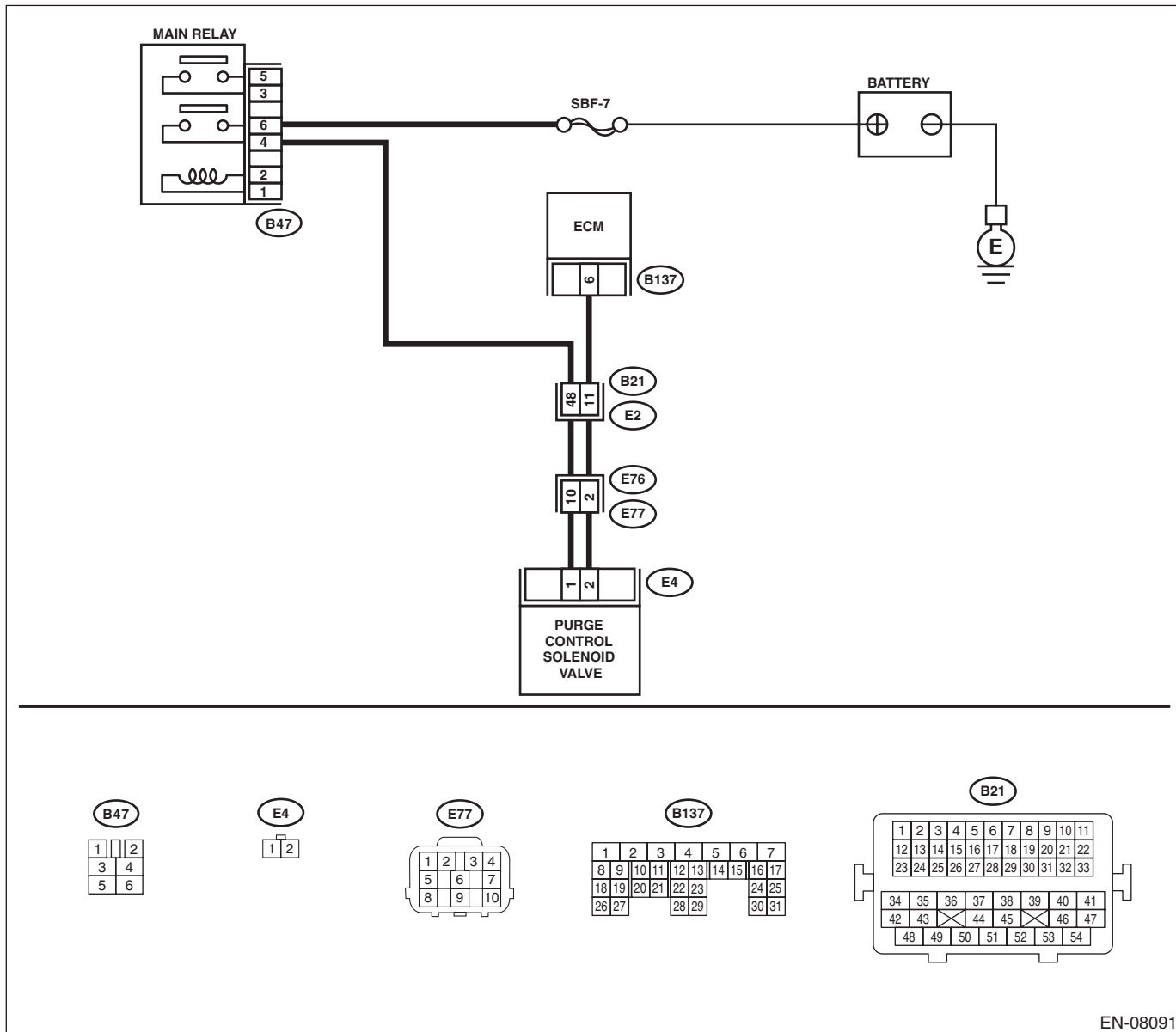

EN-08091

# Diagnostic Procedure with Diagnostic Trouble Code (DTC)

ENGINE (DIAGNOSTICS)

Step	Check	Yes	No
<b>1 CHECK FOR ANY OTHER DTC ON DISPLAY.</b>	Is DTC P0452 displayed on the display?	Replace the fuel tank. <Ref. to FU(H6DO)-60, Fuel Tank.>	Go to step 2.
<b>2 CHECK HARNESS BETWEEN ECM AND PURGE CONTROL SOLENOID VALVE.</b> 1) Turn the ignition switch to OFF. 2) Disconnect the connectors from ECM and purge control solenoid valve. 3) Turn the ignition switch to ON. 4) Measure the voltage between ECM and chassis ground. <b>Connector &amp; terminal</b> <b>(B137) No. 6 (+) — Chassis ground (-):</b>	Is the voltage 10 V or more?	Repair the short circuit to power in the harness between ECM and purge control solenoid valve connector.	Go to step 3.
<b>3 CHECK PURGE CONTROL SOLENOID VALVE.</b> 1) Turn the ignition switch to OFF. 2) Measure the resistance between purge control solenoid valve terminals. <b>Terminals</b> <b>No. 1 — No. 2:</b>	Is the resistance less than 1 $\Omega$ ?	Replace the purge control solenoid valve. <Ref. to EC(H6DO)-7, Purge Control Solenoid Valve.>	Repair the poor contact of ECM connector.

# Diagnostic Procedure with Diagnostic Trouble Code (DTC)

ENGINE (DIAGNOSTICS)

## DN:DTC P0461 FUEL LEVEL SENSOR “A” CIRCUIT RANGE/PERFORMANCE

### DTC DETECTING CONDITION:

- Detected when two consecutive driving cycles with fault occur.
- GENERAL DESCRIPTION <Ref. to GD(H6DO)-161, DTC P0461 FUEL LEVEL SENSOR “A” CIRCUIT RANGE/PERFORMANCE, Diagnostic Trouble Code (DTC) Detecting Criteria.>

### CAUTION:

After servicing or replacing faulty parts, perform Clear Memory Mode <Ref. to EN(H6DO)(diag)-62, OPERATION, Clear Memory Mode.>, and Inspection Mode <Ref. to EN(H6DO)(diag)-47, PROCEDURE, Inspection Mode.>.

Step	Check	Yes	No
1 CHECK FOR ANY OTHER DTC ON DISPLAY.	Is any other DTC displayed?	Check the appropriate DTC using the “List of Diagnostic Trouble Code (DTC)”. <Ref. to EN(H6DO)(diag)-89, List of Diagnostic Trouble Code (DTC).>	Replace the fuel level sensor and fuel sub level sensor. <Ref. to FU(H6DO)-67, Fuel Level Sensor.> <Ref. to FU(H6DO)-68, Fuel Sub Level Sensor.>

## DO:DTC P0462 FUEL LEVEL SENSOR “A” CIRCUIT LOW

### NOTE:

For the diagnostic procedure, refer to DTC P0463. <Ref. to EN(H6DO)(diag)-257, DTC P0463 FUEL LEVEL SENSOR “A” CIRCUIT HIGH, Diagnostic Procedure with Diagnostic Trouble Code (DTC).>

# Diagnostic Procedure with Diagnostic Trouble Code (DTC)

ENGINE (DIAGNOSTICS)

## DP:DTC P0463 FUEL LEVEL SENSOR "A" CIRCUIT HIGH

### DTC DETECTING CONDITION:

- Detected when two consecutive driving cycles with fault occur.
- GENERAL DESCRIPTION <Ref. to GD(H6DO)-165, DTC P0463 FUEL LEVEL SENSOR "A" CIRCUIT HIGH, Diagnostic Trouble Code (DTC) Detecting Criteria.>

### CAUTION:

After servicing or replacing faulty parts, perform Clear Memory Mode <Ref. to EN(H6DO)(diag)-62, OPERATION, Clear Memory Mode.>, and Inspection Mode <Ref. to EN(H6DO)(diag)-47, PROCEDURE, Inspection Mode.>.

Step	Check	Yes	No
1 <b>CHECK FOR ANY OTHER DTC ON DISPLAY.</b>	Is DTC P0462 or P0463 displayed on the Subaru Select Monitor?	Check the combination meter. <Ref. to IDI-4, INSPECTION, Combination Meter System.>	Even if DTC is detected, the circuit has returned to a normal condition at this time. Reproduce the failure, and then perform the diagnosis again.  NOTE: In this case, temporary poor contact of connector, temporary open or short circuit of harness may be the cause.

# Diagnostic Procedure with Diagnostic Trouble Code (DTC)

ENGINE (DIAGNOSTICS)

---

## DQ:DTC P0500 VEHICLE SPEED SENSOR “A”

### DTC DETECTING CONDITION:

- Immediately at fault recognition
- GENERAL DESCRIPTION <Ref. to GD(H6DO)-167, DTC P0500 VEHICLE SPEED SENSOR “A”, Diagnostic Trouble Code (DTC) Detecting Criteria.>

### CAUTION:

After servicing or replacing faulty parts, perform Clear Memory Mode <Ref. to EN(H6DO)(diag)-62, OPERATION, Clear Memory Mode.>, and Inspection Mode <Ref. to EN(H6DO)(diag)-47, PROCEDURE, Inspection Mode.>.

	Step	Check	Yes	No
1	<b>CHECK DTC OF VDC.</b> Check DTC of VDC.	Is DTC of VDC displayed?	Perform the diagnosis according to DTC. <Ref. to VDC(diag)-43, List of Diagnostic Trouble Code (DTC).>	Repair the poor contact of ECM connector.



# Diagnostic Procedure with Diagnostic Trouble Code (DTC)

ENGINE (DIAGNOSTICS)

## DR:DTC P0506 IDLE AIR CONTROL SYSTEM RPM LOWER THAN EXPECTED

### DTC DETECTING CONDITION:

- Detected when two consecutive driving cycles with fault occur.
- GENERAL DESCRIPTION <Ref. to GD(H6DO)-168, DTC P0506 IDLE AIR CONTROL SYSTEM RPM LOWER THAN EXPECTED, Diagnostic Trouble Code (DTC) Detecting Criteria.>

### TROUBLE SYMPTOM:

- Hard to start the engine.
- Engine does not start.
- Improper idling
- Engine stalls.

### CAUTION:

After servicing or replacing faulty parts, perform Clear Memory Mode <Ref. to EN(H6DO)(diag)-62, OPERATION, Clear Memory Mode.>, and Inspection Mode <Ref. to EN(H6DO)(diag)-47, PROCEDURE, Inspection Mode.>.

Step	Check	Yes	No
1 <b>CHECK FOR ANY OTHER DTC ON DISPLAY.</b>	Is any other DTC displayed?	Check the appropriate DTC using the "List of Diagnostic Trouble Code (DTC)". <Ref. to EN(H6DO)(diag)-89, List of Diagnostic Trouble Code (DTC).>	Go to step 2.
2 <b>CHECK AIR CLEANER ELEMENT.</b> 1) Turn the ignition switch to OFF. 2) Check the air cleaner element.	Is there excessive clogging on air cleaner element?	Replace the air cleaner element. <Ref. to IN(H6DO)-4, Air Cleaner Element.>	Go to step 3.
3 <b>CHECK ELECTRONIC THROTTLE CONTROL.</b> 1) Remove the electronic throttle control. 2) Check the electronic throttle control.	Are foreign matter found inside electronic throttle control?	Remove foreign matter from electronic throttle control.	Perform the diagnosis of DTC P2101. <Ref. to EN(H6DO)(diag)-328, DTC P2101 THROTTLE ACTUATOR CONTROL MOTOR CIRCUIT RANGE/PERFORMANCE, Diagnostic Procedure with Diagnostic Trouble Code (DTC).>

# Diagnostic Procedure with Diagnostic Trouble Code (DTC)

ENGINE (DIAGNOSTICS)

## DS:DTC P0507 IDLE AIR CONTROL SYSTEM RPM HIGHER THAN EXPECTED

### DTC DETECTING CONDITION:

- Detected when two consecutive driving cycles with fault occur.
- GENERAL DESCRIPTION <Ref. to GD(H6DO)-169, DTC P0507 IDLE AIR CONTROL SYSTEM RPM HIGHER THAN EXPECTED, Diagnostic Trouble Code (DTC) Detecting Criteria.>

### TROUBLE SYMPTOM:

Engine keeps running at higher speed than specified idle speed.

### CAUTION:

After servicing or replacing faulty parts, perform Clear Memory Mode <Ref. to EN(H6DO)(diag)-62, OPERATION, Clear Memory Mode.>, and Inspection Mode <Ref. to EN(H6DO)(diag)-47, PROCEDURE, Inspection Mode.>.

Step	Check	Yes	No
1 <b>CHECK FOR ANY OTHER DTC ON DISPLAY.</b>	Is any other DTC displayed?	Check the appropriate DTC using the "List of Diagnostic Trouble Code (DTC)". <Ref. to EN(H6DO)(diag)-89, List of Diagnostic Trouble Code (DTC).>	Go to step 2.
2 <b>CHECK AIR INTAKE SYSTEM.</b> 1) Start and idle the engine. 2) Check the following items. • Loose installation of intake manifold and throttle body • Cracks of intake manifold gasket and throttle body gasket • Disconnection of vacuum hoses	Is there any fault in air intake system?	Repair air suction and leaks.	Go to step 3.
3 <b>CHECK ELECTRONIC THROTTLE CONTROL.</b> 1) Turn the ignition switch to OFF. 2) Remove the electronic throttle control. 3) Check the electronic throttle control.	Are foreign matter found inside electronic throttle control?	Remove foreign matter from electronic throttle control.	Perform the diagnosis of DTC P2101. <Ref. to EN(H6DO)(diag)-328, DTC P2101 THROTTLE ACTUATOR CONTROL MOTOR CIRCUIT RANGE/PERFORMANCE, Diagnostic Procedure with Diagnostic Trouble Code (DTC).>

# Diagnostic Procedure with Diagnostic Trouble Code (DTC)

ENGINE (DIAGNOSTICS)

## DT:DTC P050A COLD START IDLE AIR CONTROL SYSTEM PERFORMANCE

### DTC DETECTING CONDITION:

- Detected when two consecutive driving cycles with fault occur.
- GENERAL DESCRIPTION <Ref. to GD(H6DO)-170, DTC P050A COLD START IDLE AIR CONTROL SYSTEM PERFORMANCE, Diagnostic Trouble Code (DTC) Detecting Criteria.>

### TROUBLE SYMPTOM:

- Engine keeps running at higher speed than specified idle speed.
- Engine keeps running at a lower speed than the specified idle speed.
- Engine stalls.

### CAUTION:

After servicing or replacing faulty parts, perform Clear Memory Mode <Ref. to EN(H6DO)(diag)-62, OPERATION, Clear Memory Mode.>, and Inspection Mode <Ref. to EN(H6DO)(diag)-47, PROCEDURE, Inspection Mode.>.

### WIRING DIAGRAM:

Engine electrical system <Ref. to WI-32, Engine Electrical System.>

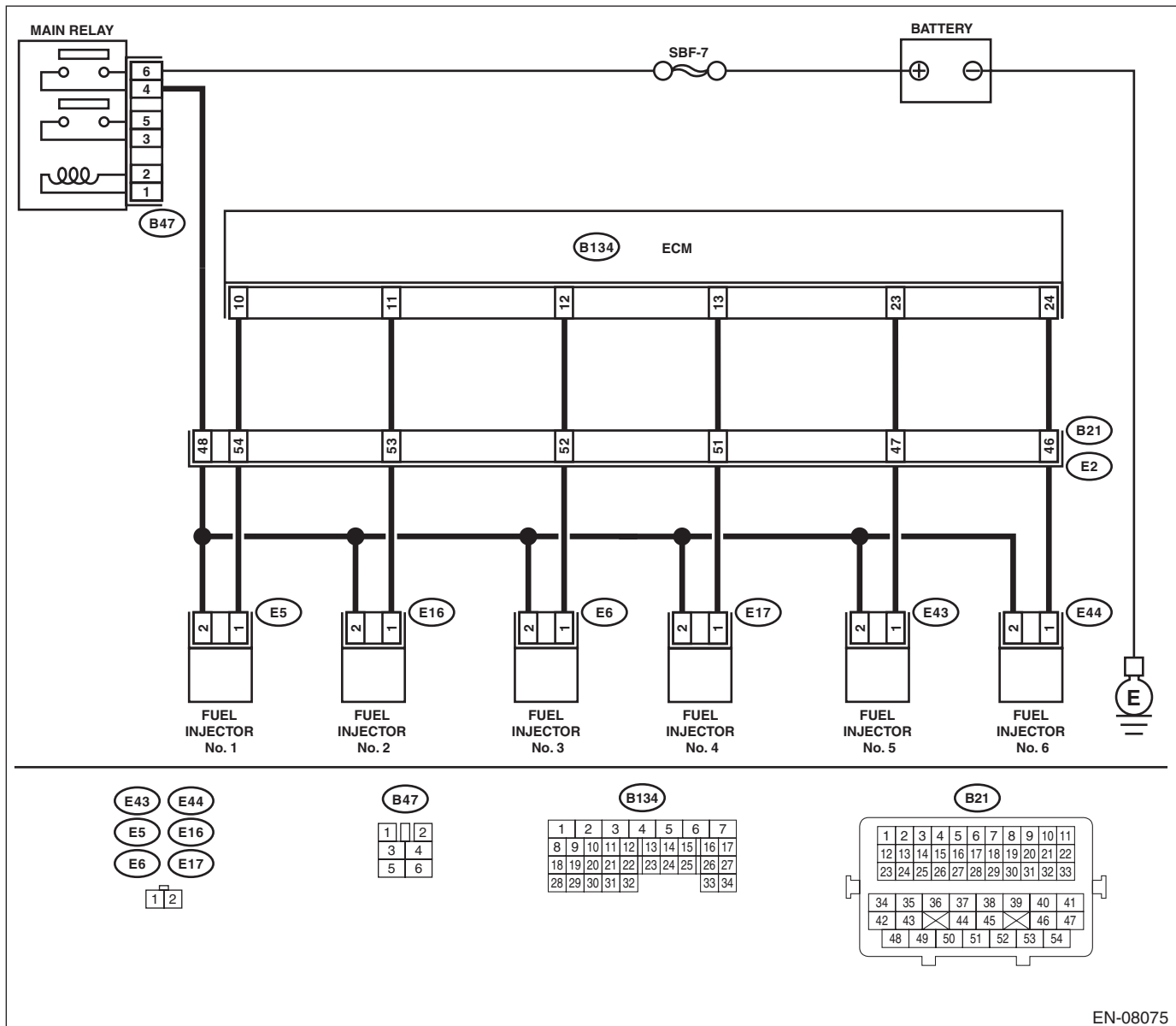

EN-08075

# Diagnostic Procedure with Diagnostic Trouble Code (DTC)

## ENGINE (DIAGNOSTICS)

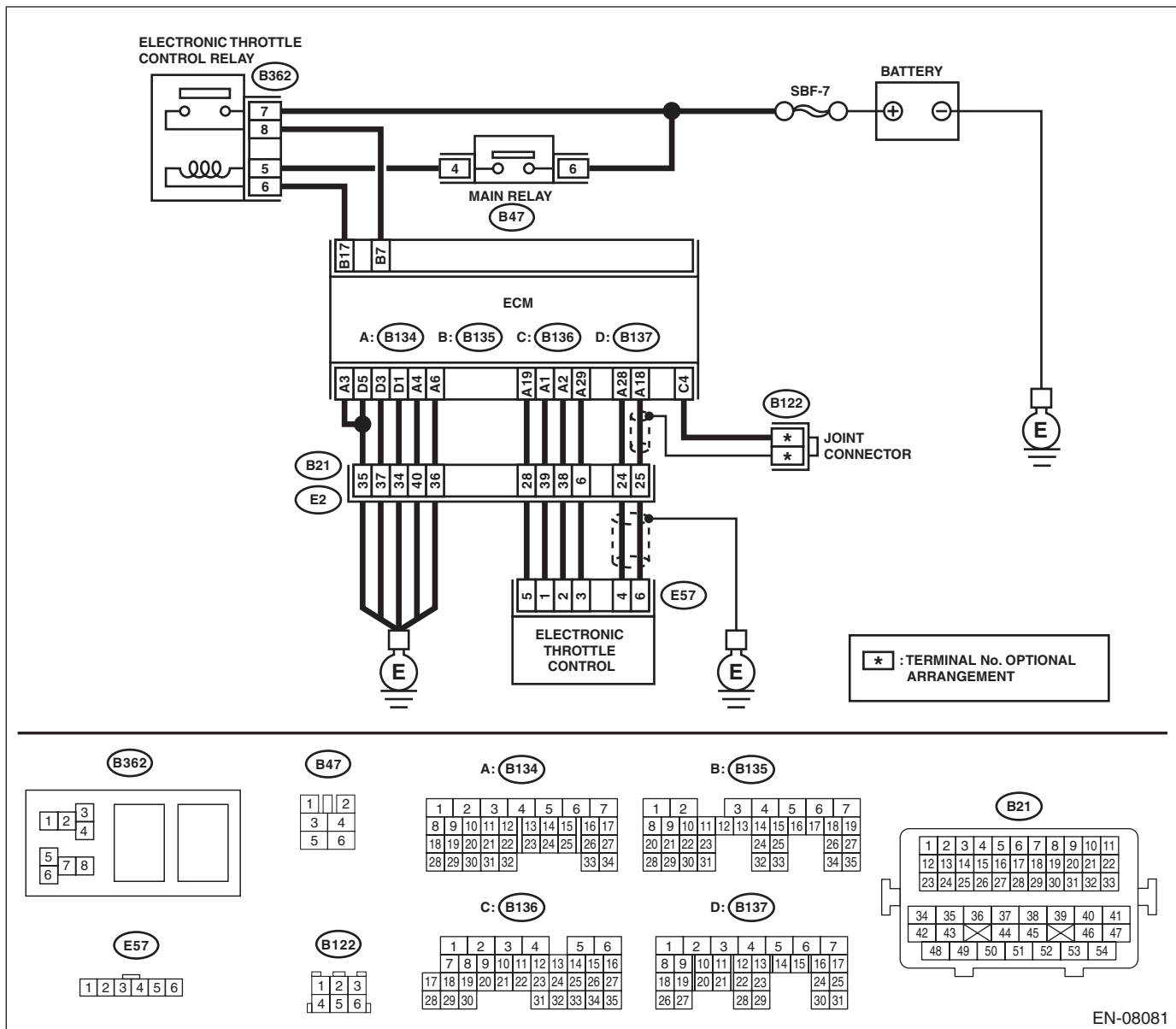

EN-08081

Step	Check	Yes	No
1	<b>CHECK FOR ANY OTHER DTC ON DISPLAY.</b> Is any other DTC displayed?	Check the appropriate DTC using the "List of Diagnostic Trouble Code (DTC)". <Ref. to EN(H6DO)(diag)-89, List of Diagnostic Trouble Code (DTC).>	Go to step 2.
2	<b>CHECK ENGINE OIL.</b> Is there a proper amount of engine oil?	Go to step 3.	Replace engine oil. <Ref. to LU(H6DO)-10, REPLACEMENT, Engine Oil.>
3	<b>CHECK EXHAUST SYSTEM.</b> Are there holes or loose bolts on exhaust system?	Repair the exhaust system.	Go to step 4.

# Diagnostic Procedure with Diagnostic Trouble Code (DTC)

ENGINE (DIAGNOSTICS)

Step	Check	Yes	No
<b>4</b> <b>CHECK AIR INTAKE SYSTEM.</b>	Are there holes, loose bolts or disconnection of hose on air intake system?	Repair the air intake system.	Go to step 5.
<b>5</b> <b>CHECK FUEL PRESSURE.</b> <b>WARNING:</b> Place “NO OPEN FLAMES” signs near the working area. <b>CAUTION:</b> Be careful not to spill fuel. Measure the fuel pressure. <Ref. to ME(H6DO)-31, INSPECTION, Fuel Pressure.> <b>CAUTION:</b> Release fuel pressure before removing the fuel pressure gauge.	Is the measured value 340 — 400 kPa (3.5 — 4.1 kgf/cm <sup>2</sup> , 49 — 58 psi)?	Go to step 6.	Repair the following item. Fuel pressure is too high: <ul style="list-style-type: none"> <li>• Clogged fuel line or bent hose</li> </ul> Fuel pressure is too low: <ul style="list-style-type: none"> <li>• Improper fuel pump discharge</li> <li>• Clogged fuel line</li> </ul>
<b>6</b> <b>CHECK ENGINE COOLANT TEMPERATURE SENSOR.</b> 1) Start the engine and warm up completely. 2) Read the value of «Coolant Temp.» using the Subaru Select Monitor or a general scan tool. <b>NOTE:</b> <ul style="list-style-type: none"> <li>• Subaru Select Monitor</li> </ul> For detailed operation procedures, refer to “READ CURRENT DATA FOR ENGINE”. <Ref. to EN(H6DO)(diag)-37, Subaru Select Monitor.> <ul style="list-style-type: none"> <li>• General scan tool</li> </ul> For detailed operation procedures, refer to the general scan tool operation manual.	Is the value of «Coolant Temp.» 75°C (167°F) or more?	Go to step 7.	Replace the engine coolant temperature sensor. <Ref. to FU(H6DO)-30, Engine Coolant Temperature Sensor.>
<b>7</b> <b>CHECK MASS AIR FLOW AND INTAKE AIR TEMPERATURE SENSOR.</b> 1) Start the engine and warm up engine until coolant temperature is higher than 75°C (167°F). 2) Place the select lever in “P” range or “N” range. 3) Turn the A/C switch to OFF. 4) Turn all the accessory switches to OFF. 5) Read the value of «Mass Air Flow» using the Subaru Select Monitor or a general scan tool. <b>NOTE:</b> <ul style="list-style-type: none"> <li>• Subaru Select Monitor</li> </ul> For detailed operation procedures, refer to “READ CURRENT DATA FOR ENGINE”. <Ref. to EN(H6DO)(diag)-37, Subaru Select Monitor.> <ul style="list-style-type: none"> <li>• General scan tool</li> </ul> For detailed operation procedures, refer to the general scan tool operation manual.	Is the value of «Mass Air Flow» 2.0 — 5.0 g/s (0.26 — 0.66 lb/m)?	Go to step 8.	Replace the mass air flow and intake air temperature sensor. <Ref. to FU(H6DO)-40, Mass Air Flow and Intake Air Temperature Sensor.>

# Diagnostic Procedure with Diagnostic Trouble Code (DTC)

## ENGINE (DIAGNOSTICS)

Step	Check	Yes	No
<p><b>8</b></p> <p><b>CHECK MASS AIR FLOW AND INTAKE AIR TEMPERATURE SENSOR.</b></p> <p>1) Start the engine and warm up engine until coolant temperature is higher than 75°C (167°F).</p> <p>2) Place the select lever in “P” range or “N” range.</p> <p>3) Turn the A/C switch to OFF.</p> <p>4) Turn all the accessory switches to OFF.</p> <p>5) Open the front hood.</p> <p>6) Measure the ambient temperature.</p> <p>7) Read the value of «Intake Air Temp.» using the Subaru Select Monitor or a general scan tool.</p> <p>NOTE:</p> <ul style="list-style-type: none"> <li>• Subaru Select Monitor</li> </ul> <p>For detailed operation procedures, refer to “READ CURRENT DATA FOR ENGINE”. &lt;Ref. to EN(H6DO)(diag)-37, Subaru Select Monitor.&gt;</p> <ul style="list-style-type: none"> <li>• General scan tool</li> </ul> <p>For detailed operation procedures, refer to the general scan tool operation manual.</p>	<p>Subtract ambient temperature from «Intake Air Temp.». Is the obtained value -10 — 50°C (-18 — 90°F)?</p>	Go to step 9.	Check the mass air flow and intake air temperature sensor. <Ref. to FU(H6DO)-40, Mass Air Flow and Intake Air Temperature Sensor.>
<p><b>9</b></p> <p><b>CHECK OUTPUT SIGNAL OF ECM.</b></p> <p>1) Turn the ignition switch to ON.</p> <p>2) Measure the voltage between ECM and chassis ground on faulty cylinders.</p> <p><b>Connector &amp; terminal</b></p> <p><b>#1 (B134) No. 10 (+) — Chassis ground (-):</b></p> <p><b>#2 (B134) No. 11 (+) — Chassis ground (-):</b></p> <p><b>#3 (B134) No. 12 (+) — Chassis ground (-):</b></p> <p><b>#4 (B134) No. 13 (+) — Chassis ground (-):</b></p> <p><b>#5 (B134) No. 23 (+) — Chassis ground (-):</b></p> <p><b>#6 (B134) No. 24 (+) — Chassis ground (-):</b></p>	Is the voltage 10 V or more?	Go to step 14.	Go to step 10.
<p><b>10</b></p> <p><b>CHECK HARNESS BETWEEN ECM AND FUEL INJECTOR.</b></p> <p>1) Turn the ignition switch to OFF.</p> <p>2) Disconnect the connector from fuel injector on faulty cylinders.</p> <p>3) Measure the resistance between fuel injector connector and engine ground on faulty cylinders.</p> <p><b>Connector &amp; terminal</b></p> <p><b>#1 (E5) No. 1 — Engine ground:</b></p> <p><b>#2 (E16) No. 1 — Engine ground:</b></p> <p><b>#3 (E6) No. 1 — Engine ground:</b></p> <p><b>#4 (E17) No. 1 — Engine ground:</b></p> <p><b>#5 (E43) No. 1 — Engine ground:</b></p> <p><b>#6 (E44) No. 1 — Engine ground:</b></p>	Is the resistance 1 MΩ or more?	Go to step 11.	Repair the ground short circuit of harness between ECM and fuel injector.
<p><b>11</b></p> <p><b>CHECK HARNESS BETWEEN ECM AND FUEL INJECTOR.</b></p> <p>Measure the resistance of harness between ECM and fuel injector on faulty cylinders.</p> <p><b>Connector &amp; terminal</b></p> <p><b>#1 (B134) No. 10 — (E5) No. 1:</b></p> <p><b>#2 (B134) No. 11 — (E16) No. 1:</b></p> <p><b>#3 (B134) No. 12 — (E6) No. 1:</b></p> <p><b>#4 (B134) No. 13 — (E17) No. 1:</b></p> <p><b>#5 (B134) No. 23 — (E43) No. 1:</b></p> <p><b>#6 (B134) No. 24 — (E44) No. 1:</b></p>	Is the resistance less than 1 Ω?	Go to step 12.	Repair the harness and connector. NOTE: In this case, repair the following item: • Open circuit in harness between ECM and fuel injector connector • Poor contact of coupling connector

# Diagnostic Procedure with Diagnostic Trouble Code (DTC)

ENGINE (DIAGNOSTICS)

Step	Check	Yes	No
<b>12 CHECK FUEL INJECTOR.</b> Measure the resistance between fuel injector terminals on faulty cylinder. <i>Terminals</i> <i>No. 1 — No. 2:</i>	Is the resistance 5 — 20 Ω?	Go to step 13.	Replace the faulty fuel injector. <Ref. to FU(H6DO)-42, Fuel Injector.>
<b>13 CHECK POWER SUPPLY LINE.</b> 1) Turn the ignition switch to ON. 2) Measure the voltage between fuel injector and engine ground on faulty cylinders. <i>Connector &amp; terminal</i> <i>#1 (E5) No. 2 (+) — Engine ground (-):</i> <i>#2 (E16) No. 2 (+) — Engine ground (-):</i> <i>#3 (E6) No. 2 (+) — Engine ground (-):</i> <i>#4 (E17) No. 2 (+) — Engine ground (-):</i> <i>#5 (E43) No. 2 (+) — Engine ground (-):</i> <i>#6 (E44) No. 2 (+) — Engine ground (-):</i>	Is the voltage 10 V or more?	Repair the poor contact of all connectors in fuel injector circuit.	Repair the harness and connector. NOTE: In this case, repair the following item: • Open circuit in harness between the main relay and fuel injector on faulty cylinders • Poor contact of coupling connector • Poor contact of main relay connector
<b>14 CHECK HARNESS BETWEEN ECM AND FUEL INJECTOR.</b> 1) Turn the ignition switch to OFF. 2) Disconnect the connector from fuel injector on faulty cylinders. 3) Turn the ignition switch to ON. 4) Measure the voltage between ECM and chassis ground on faulty cylinders. <i>Connector &amp; terminal</i> <i>#1 (B134) No. 10 (+) — Chassis ground (-):</i> <i>#2 (B134) No. 11 (+) — Chassis ground (-):</i> <i>#3 (B134) No. 12 (+) — Chassis ground (-):</i> <i>#4 (B134) No. 13 (+) — Chassis ground (-):</i> <i>#5 (B134) No. 23 (+) — Chassis ground (-):</i> <i>#6 (B134) No. 24 (+) — Chassis ground (-):</i>	Is the voltage 10 V or more?	Repair the short circuit to power in the harness between the ECM and fuel injector.	Go to step 15.
<b>15 CHECK FUEL INJECTOR.</b> 1) Turn the ignition switch to OFF. 2) Measure the resistance between fuel injector terminals on faulty cylinder. <i>Terminals</i> <i>No. 1 — No. 2:</i>	Is the resistance 5 — 20 Ω?	Go to step 16.	Replace the faulty fuel injector. <Ref. to FU(H6DO)-42, Fuel Injector.>
<b>16 CHECK INSTALLATION OF CAMSHAFT POSITION SENSOR/CRANKSHAFT POSITION SENSOR.</b>	Is the camshaft position sensor or crankshaft position sensor loosely installed?	Tighten the camshaft position sensor or crankshaft position sensor.	Go to step 17.
<b>17 CHECK CRANK PLATE.</b>	Is the crank sprocket rusted or the teeth of crank plate broken?	Replace the crank plate. <Ref. to ME(H6DO)-97, Cylinder Block.>	Go to step 18.
<b>18 CHECK INSTALLATION CONDITION OF TIMING CHAIN.</b> Turn the crankshaft using ST, and align the alignment mark on crank sprocket with alignment mark on cylinder block. ST 18252AA000 CRANKSHAFT SOCKET	Is the timing chain dislocated from its proper position?	Correct the installation condition of timing chain. <Ref. to ME(H6DO)-54, Timing Chain Assembly.>	Go to step 19.

# Diagnostic Procedure with Diagnostic Trouble Code (DTC)

## ENGINE (DIAGNOSTICS)

Step	Check	Yes	No
<b>19 CHECK ELECTRONIC THROTTLE CONTROL RELAY.</b> 1) Turn the ignition switch to OFF. 2) Remove the electronic throttle control relay. 3) Connect the battery to terminals No. 5 and No. 6 of electronic throttle control relay. 4) Measure the resistance between electronic throttle control relay terminals. <i>Terminals</i> <i>No. 7 — No. 8:</i>	Is the resistance less than 1 $\Omega$ ?	Go to step 20.	Replace the electronic throttle control relay. <Ref. to EN(H6DO)(diag)-9, Electrical Component Location.>
<b>20 CHECK POWER SUPPLY OF ELECTRONIC THROTTLE CONTROL RELAY.</b> Measure the voltage between electronic throttle control relay connector and chassis ground. <i>Connector &amp; terminal</i> <i>(B362) No. 7 (+) — Chassis ground (-):</i>	Is the voltage 10 V or more?	Go to step 21.	Repair the open or ground short circuit of power supply circuit.
<b>21 CHECK HARNESS BETWEEN ECM AND ELECTRONIC THROTTLE CONTROL RELAY.</b> 1) Disconnect the connector from ECM. 2) Turn the ignition switch to ON. 3) Measure the voltage between electronic throttle control relay connector and chassis ground. <i>Connector &amp; terminal</i> <i>(B362) No. 6 (+) — Chassis ground (-):</i>	Is the voltage 10 V or more?	Repair the short circuit to power in harness between ECM and electronic throttle control relay.	Go to step 22.
<b>22 CHECK HARNESS BETWEEN ECM AND ELECTRONIC THROTTLE CONTROL RELAY.</b> 1) Turn the ignition switch to OFF. 2) Measure the resistance between electronic throttle control relay connector and chassis ground. <i>Connector &amp; terminal</i> <i>(B362) No. 6 — Chassis ground:</i> <i>(B362) No. 8 — Chassis ground:</i>	Is the resistance 1 M $\Omega$ or more?	Go to step 23.	Repair the ground short circuit of harness between ECM and electronic throttle control relay.
<b>23 CHECK HARNESS BETWEEN ECM AND ELECTRONIC THROTTLE CONTROL RELAY.</b> Measure the resistance between ECM and electronic throttle control relay connector. <i>Connector &amp; terminal</i> <i>(B135) No. 17 — (B362) No. 6:</i> <i>(B135) No. 7 — (B362) No. 8:</i>	Is the resistance less than 1 $\Omega$ ?	Go to step 24.	Repair the open circuit of harness between ECM and electronic throttle control relay.
<b>24 CHECK HARNESS BETWEEN ECM AND ELECTRONIC THROTTLE CONTROL.</b> 1) Turn the ignition switch to OFF. 2) Disconnect the connectors from ECM and electronic throttle control. 3) Measure the resistance between ECM and chassis ground. <i>Connector &amp; terminal</i> <i>(B134) No. 19 — Chassis ground:</i> <i>(B134) No. 18 — Chassis ground:</i> <i>(B134) No. 18 — (B136) No. 4:</i> <i>(B134) No. 28 — Chassis ground:</i>	Is the resistance 1 M $\Omega$ or more?	Go to step 25.	Repair the short circuit to ground in harness between ECM and electronic throttle control connector.



# Diagnostic Procedure with Diagnostic Trouble Code (DTC)

ENGINE (DIAGNOSTICS)

Step	Check	Yes	No
<p><b>25 CHECK SHORT CIRCUIT INSIDE THE ECM.</b>                      1) Connect the connector to ECM.                      2) Measure the resistance between electronic throttle control connector and engine ground.  <b>Connector &amp; terminal</b>                      (E57) No. 6 — Engine ground:                      (E57) No. 4 — Engine ground:</p>	Is the resistance 1 M $\Omega$ or more?	Go to step 26.	Repair the short circuit to ground in harness between ECM and electronic throttle control connector. Replace the ECM if defective. <Ref. to FU(H6DO)-51, Engine Control Module (ECM).>
<p><b>26 CHECK HARNESS BETWEEN ECM AND ELECTRONIC THROTTLE CONTROL.</b>                      1) Disconnect the connector from ECM.                      2) Measure the resistance of harness between ECM and electronic throttle control connector.  <b>Connector &amp; terminal</b>                      (B134) No. 18 — (E57) No. 6:                      (B134) No. 28 — (E57) No. 4:                      (B134) No. 29 — (E57) No. 3:</p>	Is the resistance less than 1 $\Omega$ ?	Go to step 27.	Repair the harness and connector. NOTE: In this case, repair the following item: • Open circuit in harness between ECM and electronic throttle control connector • Poor contact of coupling connector
<p><b>27 CHECK HARNESS BETWEEN ECM AND ELECTRONIC THROTTLE CONTROL.</b>                      1) Connect the connector to ECM.                      2) Measure the resistance between electronic throttle control connector and engine ground.  <b>Connector &amp; terminal</b>                      (E57) No. 3 — Engine ground:</p>	Is the resistance less than 5 $\Omega$ ?	Go to step 28.	Repair the harness and connector. NOTE: In this case, repair the following item: • Open circuit of harness between ECM and engine ground • Poor contact of ECM connector • Poor contact of coupling connector
<p><b>28 CHECK HARNESS BETWEEN ECM AND ELECTRONIC THROTTLE CONTROL.</b>                      1) Turn the ignition switch to ON.                      2) Measure the voltage between electronic throttle control connector and engine ground.  <b>Connector &amp; terminal</b>                      (E57) No. 6 (+) — Engine ground (-):                      (E57) No. 4 (+) — Engine ground (-):</p>	Is the voltage 5 V or more?	Repair the short circuit to power in harness between ECM and electronic throttle control connector.	Go to step 29.
<p><b>29 CHECK HARNESS BETWEEN ECM AND ELECTRONIC THROTTLE CONTROL.</b>                      1) Turn the ignition switch to OFF.                      2) Disconnect the connector from ECM.                      3) Measure the resistance between ECM connectors.  <b>Connector &amp; terminal</b>                      (B134) No. 19 — (B134) No. 18:                      (B134) No. 19 — (B134) No. 28:</p>	Is the resistance 1 M $\Omega$ or more?	Go to step 30.	Repair the short circuit to power in harness between ECM and electronic throttle control connector.

# Diagnostic Procedure with Diagnostic Trouble Code (DTC)

## ENGINE (DIAGNOSTICS)

Step	Check	Yes	No
<b>30 CHECK SENSOR OUTPUT.</b> 1) Connect all connectors. 2) Turn the ignition switch to ON. 3) Read the value of «Main-Throttle Sensor» using Subaru Select Monitor. NOTE: For detailed operation procedures, refer to “READ CURRENT DATA FOR ENGINE”. <Ref. to EN(H6DO)(diag)-37, Subaru Select Monitor.>	Is the value of «Main-Throttle Sensor» 0.81 — 0.87 V?	Go to step 31.	Repair the poor contact of electronic throttle control connector. Replace the electronic throttle control if defective. <Ref. to FU(H6DO)-19, Throttle Body.>
<b>31 CHECK SENSOR OUTPUT.</b> Read the value of «Sub-Throttle Sensor» using Subaru Select Monitor. NOTE: For detailed operation procedures, refer to “READ CURRENT DATA FOR ENGINE”. <Ref. to EN(H6DO)(diag)-37, Subaru Select Monitor.>	Is the value of «Sub-Throttle Sensor» 1.64 — 1.70 V?	Go to step 32.	Repair the poor contact of electronic throttle control connector. Replace the electronic throttle control if defective. <Ref. to FU(H6DO)-19, Throttle Body.>
<b>32 CHECK HARNESS BETWEEN ECM AND ELECTRONIC THROTTLE CONTROL MOTOR.</b> 1) Turn the ignition switch to OFF. 2) Disconnect the connectors from ECM and electronic throttle control. 3) Measure the resistance between ECM and electronic throttle control connector. <i>Connector &amp; terminal</i> (B134) No. 1 — (E57) No. 1: (B134) No. 2 — (E57) No. 2:	Is the resistance less than 1 Ω?	Go to step 33.	Repair the harness and connector. NOTE: In this case, repair the following item: • Open circuit in harness between ECM and electronic throttle control • Poor contact of coupling connector
<b>33 CHECK HARNESS BETWEEN ECM AND ELECTRONIC THROTTLE CONTROL MOTOR.</b> 1) Connect the connector to ECM. 2) Turn the ignition switch to ON. 3) Measure the voltage between electronic throttle control connector and engine ground. <i>Connector &amp; terminal</i> (E57) No. 2 (+) — Engine ground (-): (E57) No. 1 (+) — Engine ground (-):	Is the voltage 5 V or more?	Repair the short circuit to power in the harness between ECM and electronic throttle control.	Go to step 34.
<b>34 CHECK HARNESS BETWEEN ECM AND ELECTRONIC THROTTLE CONTROL MOTOR.</b> 1) Turn the ignition switch to OFF. 2) Disconnect the connector from ECM. 3) Measure the resistance between electronic throttle control connector and engine ground. <i>Connector &amp; terminal</i> (E57) No. 2 — Engine ground: (E57) No. 1 — Engine ground:	Is the resistance 1 MΩ or more?	Go to step 35.	Repair the short circuit to ground in harness between ECM and electronic throttle control.
<b>35 CHECK ELECTRONIC THROTTLE CONTROL MOTOR HARNESS.</b> Measure the resistance between electronic throttle control connectors. <i>Connector &amp; terminal</i> (E57) No. 2 — (E57) No. 1:	Is the resistance 1 MΩ or more?	Go to step 36.	Repair the short circuit of harness between ECM and electronic throttle control.

# Diagnostic Procedure with Diagnostic Trouble Code (DTC)

ENGINE (DIAGNOSTICS)

Step	Check	Yes	No
<b>36</b> <b>CHECK ELECTRONIC THROTTLE CONTROL GROUND CIRCUIT.</b> Measure the resistance between ECM and chassis ground. <b>Connector &amp; terminal</b> <i>(B134) No. 3 — Chassis ground:</i> <i>(B134) No. 4 — Chassis ground:</i> <i>(B134) No. 6 — Chassis ground:</i> <i>(B137) No. 1 — Chassis ground:</i> <i>(B137) No. 3 — Chassis ground:</i> <i>(B137) No. 5 — Chassis ground:</i>	Is the resistance less than 5 $\Omega$ ?	Go to step 37.	Repair the harness and connector. NOTE: In this case, repair the following item: • Open circuit of harness between ECM and engine ground • Poor contact of coupling connector
<b>37</b> <b>CHECK ELECTRONIC THROTTLE CONTROL.</b> Measure the resistance between electronic throttle control terminals. <b>Terminals</b> <b>No. 2 — No. 1:</b>	Is the resistance 50 $\Omega$ or less?	Go to step 38.	Replace the electronic throttle control. <Ref. to FU(H6DO)-19, Throttle Body.>
<b>38</b> <b>CHECK ELECTRONIC THROTTLE CONTROL.</b> Move the throttle valve to the fully open and fully closed positions with fingers. Check that the valve returns to the specified position when releasing fingers.	Does the valve return to the specified position? Standard value: 3 mm (0.12 in) from fully closed position	Repair the poor contact of ECM connector.	Replace the electronic throttle control. <Ref. to FU(H6DO)-19, Throttle Body.>

## DU:DTC P050B COLD START IGNITION TIMING PERFORMANCE

NOTE:

For the diagnostic procedure, refer to DTC P050A. <Ref. to EN(H6DO)(diag)-261, DTC P050A COLD START IDLE AIR CONTROL SYSTEM PERFORMANCE, Diagnostic Procedure with Diagnostic Trouble Code (DTC).>

# Diagnostic Procedure with Diagnostic Trouble Code (DTC)

ENGINE (DIAGNOSTICS)

## DV:DTC P0560 SYSTEM VOLTAGE

### DTC DETECTING CONDITION:

- Immediately at fault recognition
- GENERAL DESCRIPTION <Ref. to GD(H6DO)-175, DTC P0560 SYSTEM VOLTAGE, Diagnostic Trouble Code (DTC) Detecting Criteria.>

### CAUTION:

After servicing or replacing faulty parts, perform Clear Memory Mode <Ref. to EN(H6DO)(diag)-62, OPERATION, Clear Memory Mode.>, and Inspection Mode <Ref. to EN(H6DO)(diag)-47, PROCEDURE, Inspection Mode.>.

### WIRING DIAGRAM:

Engine electrical system <Ref. to WI-32, Engine Electrical System.>

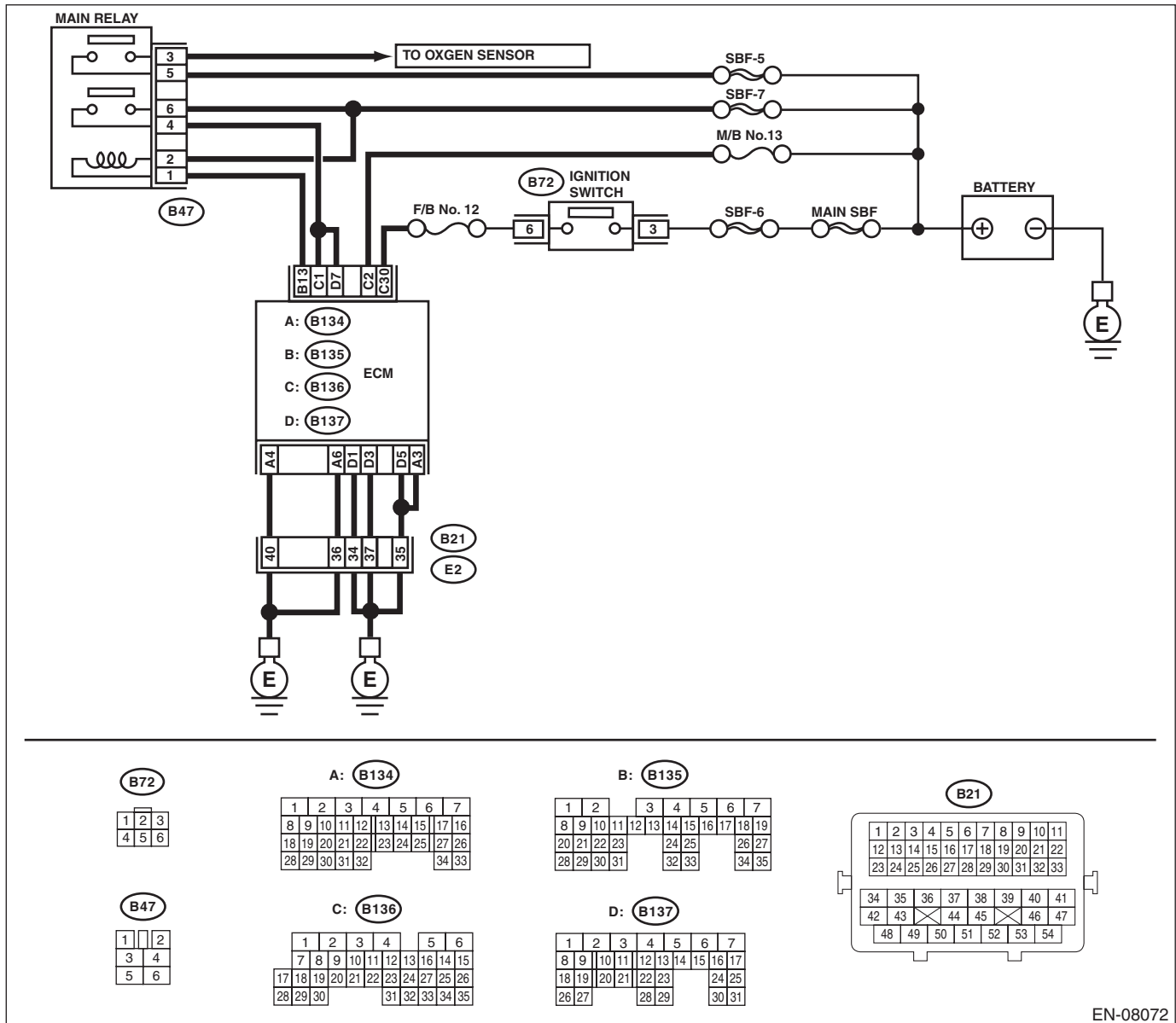

EN-08072

# Diagnostic Procedure with Diagnostic Trouble Code (DTC)

ENGINE (DIAGNOSTICS)

Step	Check	Yes	No
<b>1</b> <b>CHECK INPUT SIGNAL OF ECM.</b> 1) Turn the ignition switch to OFF. 2) Measure the voltage between ECM and chassis ground. <i><b>Connector &amp; terminal</b></i> <i><b>(B136) No. 2 (+) — Chassis ground (-):</b></i>	Is the voltage 10 V or more?	Repair the poor contact of ECM connector.	Go to step 2.
<b>2</b> <b>CHECK HARNESS BETWEEN ECM AND MAIN FUSE BOX CONNECTOR.</b> 1) Disconnect the connector from ECM. 2) Measure the resistance between ECM and chassis ground. <i><b>Connector &amp; terminal</b></i> <i><b>(B136) No. 2 — Chassis ground:</b></i>	Is the resistance 1 MΩ or more?	Go to step 3.	Repair the ground short circuit of harness between ECM and battery terminal.
<b>3</b> <b>CHECK M/B FUSE NO. 13.</b>	Is the fuse blown out?	Replace the fuse.	Repair the harness and connector. NOTE: In this case, repair the following item: <ul style="list-style-type: none"> <li>• Open circuit in harness between ECM and battery</li> <li>• Poor contact of ECM connector</li> <li>• Poor contact of battery terminal</li> </ul>

# Diagnostic Procedure with Diagnostic Trouble Code (DTC)

ENGINE (DIAGNOSTICS)

## DW:DTC P0604 INTERNAL CONTROL MODULE RANDOM ACCESS MEMORY (RAM) ERROR

### DTC DETECTING CONDITION:

- Immediately at fault recognition
- GENERAL DESCRIPTION <Ref. to GD(H6DO)-176, DTC P0604 INTERNAL CONTROL MODULE RANDOM ACCESS MEMORY (RAM) ERROR, Diagnostic Trouble Code (DTC) Detecting Criteria.>

### TROUBLE SYMPTOM:

- Engine does not start.
- Engine stalls.

### CAUTION:

After servicing or replacing faulty parts, perform Clear Memory Mode <Ref. to EN(H6DO)(diag)-62, OPERATION, Clear Memory Mode.>, and Inspection Mode <Ref. to EN(H6DO)(diag)-47, PROCEDURE, Inspection Mode.>.

Step	Check	Yes	No
1 CHECK FOR ANY OTHER DTC ON DISPLAY.	Is any other DTC displayed?	Check the appropriate DTC using the "List of Diagnostic Trouble Code (DTC)". <Ref. to EN(H6DO)(diag)-89, List of Diagnostic Trouble Code (DTC).>	Even if DTC is detected, the circuit has returned to a normal condition at this time. Reproduce the failure, and then perform the diagnosis again.  NOTE: In this case, temporary poor contact of connector, temporary open or short circuit of harness may be the cause.

## DX:DTC P0605 INTERNAL CONTROL MODULE READ ONLY MEMORY (ROM) ERROR

### NOTE:

For the diagnostic procedure, refer to DTC P0606. <Ref. to EN(H6DO)(diag)-273, DTC P0606 CONTROL MODULE PROCESSOR, Diagnostic Procedure with Diagnostic Trouble Code (DTC).>

# Diagnostic Procedure with Diagnostic Trouble Code (DTC)

ENGINE (DIAGNOSTICS)

## DY:DTC P0606 CONTROL MODULE PROCESSOR

### DTC DETECTING CONDITION:

- Immediately at fault recognition
- GENERAL DESCRIPTION <Ref. to GD(H6DO)-178, DTC P0606 CONTROL MODULE PROCESSOR, Diagnostic Trouble Code (DTC) Detecting Criteria.>

### TROUBLE SYMPTOM:

- Improper idling
- Poor driving performance

### CAUTION:

After servicing or replacing faulty parts, perform Clear Memory Mode <Ref. to EN(H6DO)(diag)-62, OPERATION, Clear Memory Mode.>, and Inspection Mode <Ref. to EN(H6DO)(diag)-47, PROCEDURE, Inspection Mode.>.

### WIRING DIAGRAM:

Engine electrical system <Ref. to WI-32, Engine Electrical System.>

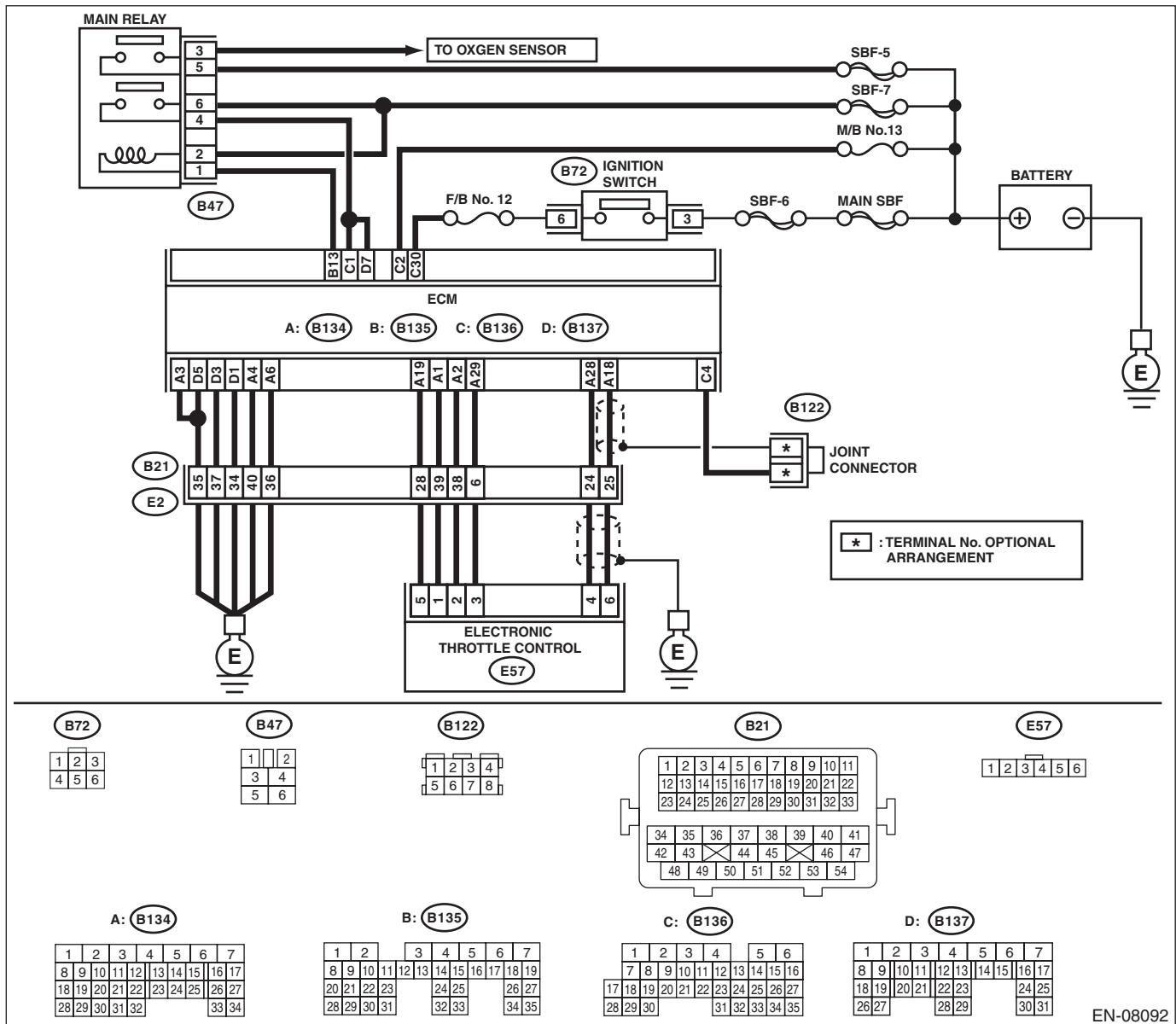

EN-08092

## Diagnostic Procedure with Diagnostic Trouble Code (DTC)

ENGINE (DIAGNOSTICS)

Step	Check	Yes	No
<b>1 CHECK INPUT VOLTAGE OF ECM.</b> 1) Turn the ignition switch to ON. 2) Measure the voltage between ECM and chassis ground. <i>Connector &amp; terminal</i> (B136) No. 1 (+) — Chassis ground (-): (B137) No. 7 (+) — Chassis ground (-):	Is the voltage 10 — 13 V?	Go to step 2.	Repair the open or ground short circuit of power supply circuit.
<b>2 CHECK INPUT VOLTAGE OF ECM.</b> 1) Start the engine. 2) Measure the voltage between ECM and chassis ground. <i>Connector &amp; terminal</i> (B136) No. 1 (+) — Chassis ground (-): (B137) No. 7 (+) — Chassis ground (-):	Is the voltage 13 — 15 V?	Go to step 3.	Repair the open or ground short circuit of power supply circuit.
<b>3 CHECK HARNESS BETWEEN ECM AND ELECTRONIC THROTTLE CONTROL.</b> 1) Turn the ignition switch to OFF. 2) Disconnect the connectors from ECM and electronic throttle control. 3) Measure the resistance of harness between ECM and electronic throttle control connector. <i>Connector &amp; terminal</i> (B134) No. 19 — (E57) No. 5: (B134) No. 29 — (E57) No. 3:	Is the resistance less than 1 $\Omega$ ?	Go to step 4.	Repair the harness and connector. NOTE: In this case, repair the following item: • Open circuit in harness between ECM and electronic throttle control connector • Poor contact of coupling connector
<b>4 CHECK ECM GROUND HARNESS.</b> 1) Connect all connectors. 2) Turn the ignition switch to ON. 3) Measure the voltage between ECM and chassis ground. <i>Connector &amp; terminal</i> (B134) No. 3 (+) — Chassis ground (-): (B134) No. 4 (+) — Chassis ground (-): (B134) No. 6 (+) — Chassis ground (-): (B137) No. 1 (+) — Chassis ground (-): (B137) No. 3 (+) — Chassis ground (-): (B137) No. 5 (+) — Chassis ground (-):	Is the voltage less than 1 V?	Repair the poor contact of ECM connector.	Repair the harness and connector. NOTE: In this case, repair the following item: • Open circuit in ground circuit • Loose engine ground terminal • Poor contact of coupling connector

### DZ:DTC P060A INTERNAL CONTROL MODULE MONITORING PROCESSOR PERFORMANCE

NOTE:

For the diagnostic procedure, refer to DTC P0606. <Ref. to EN(H6DO)(diag)-273, DTC P0606 CONTROL MODULE PROCESSOR, Diagnostic Procedure with Diagnostic Trouble Code (DTC).>

### EA:DTC P060B INTERNAL CONTROL MODULE A/D PROCESSING PERFORMANCE

NOTE:

For the diagnostic procedure, refer to DTC P0606. <Ref. to EN(H6DO)(diag)-273, DTC P0606 CONTROL MODULE PROCESSOR, Diagnostic Procedure with Diagnostic Trouble Code (DTC).>



# Diagnostic Procedure with Diagnostic Trouble Code (DTC)

ENGINE (DIAGNOSTICS)

## EB:DTC P0616 STARTER RELAY CIRCUIT LOW

### DTC DETECTING CONDITION:

- Immediately at fault recognition
- GENERAL DESCRIPTION <Ref. to GD(H6DO)-184, DTC P0616 STARTER RELAY CIRCUIT LOW, Diagnostic Trouble Code (DTC) Detecting Criteria.>

### TROUBLE SYMPTOM:

Failure of engine to start

### CAUTION:

After servicing or replacing faulty parts, perform Clear Memory Mode <Ref. to EN(H6DO)(diag)-62, OPERATION, Clear Memory Mode.>, and Inspection Mode <Ref. to EN(H6DO)(diag)-47, PROCEDURE, Inspection Mode.>.

### WIRING DIAGRAM:

Engine electrical system <Ref. to WI-32, Engine Electrical System.>

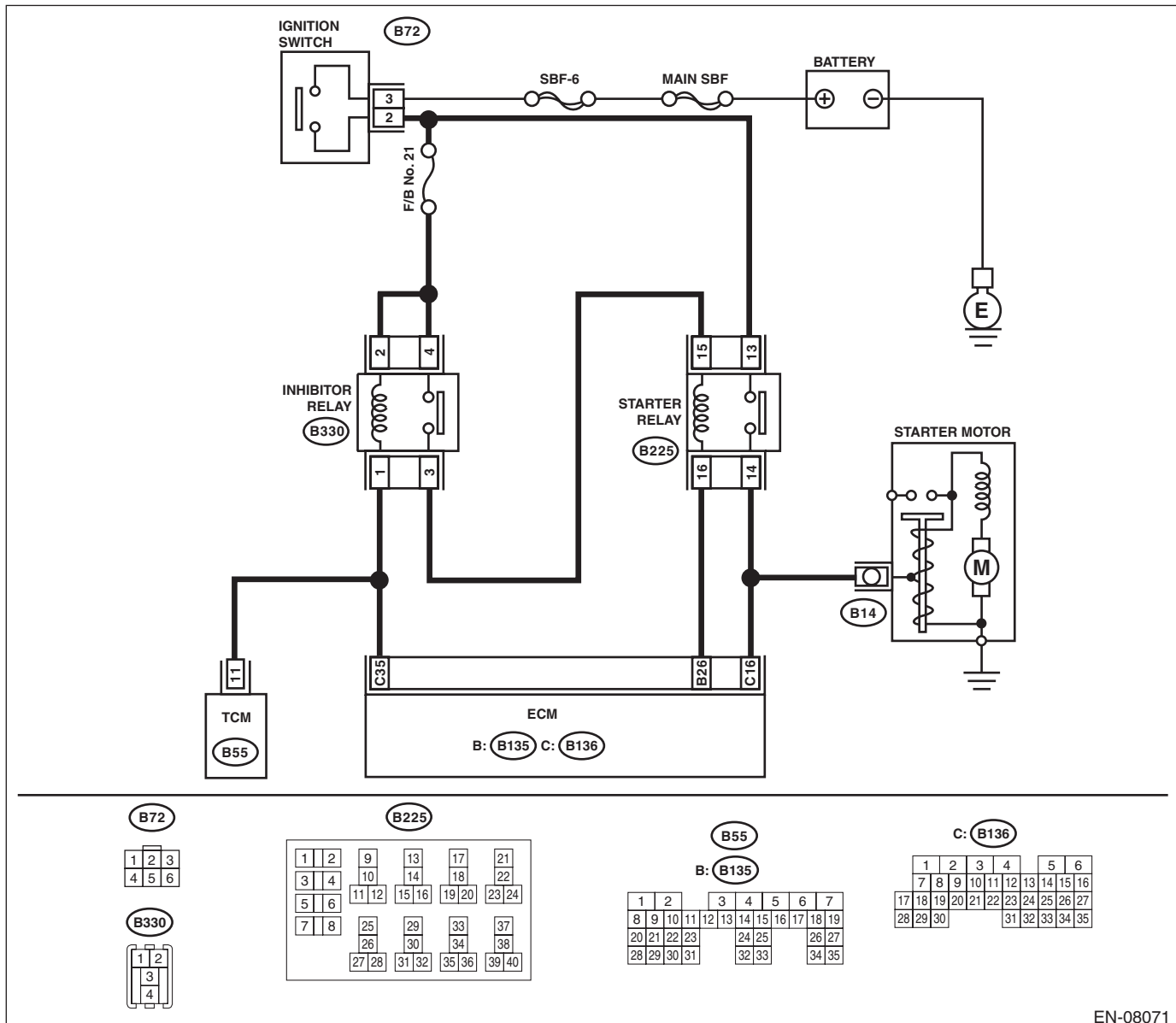

EN-08071

# Diagnostic Procedure with Diagnostic Trouble Code (DTC)

ENGINE (DIAGNOSTICS)

Step	Check	Yes	No
<b>1 CHECK FOR ANY OTHER DTC ON DISPLAY.</b>	Is any other DTC displayed?	Check DTC using "List of Diagnostic Trouble Code (DTC)". <Ref. to EN(H6DO)(diag)-89, List of Diagnostic Trouble Code (DTC).>	Go to step 2.
<b>2 CHECK HARNESS BETWEEN ECM AND STARTER RELAY CONNECTOR.</b> 1) Turn the ignition switch to OFF. 2) Remove the starter relay. 3) Disconnect the connectors from ECM and starter motor. 4) Measure the resistance of harness between ECM and starter relay connector. <b>Connector &amp; terminal</b> <b>(B136) No. 16 — (B225) No. 14:</b>	Is the resistance less than 1 Ω?	Go to step 3.	Repair the open circuit of harness between ECM and starter relay connector.
<b>3 CHECK HARNESS BETWEEN ECM AND STARTER RELAY CONNECTOR.</b> Measure the resistance between ECM and chassis ground. <b>Connector &amp; terminal</b> <b>(B136) No. 16 — Chassis ground:</b>	Is the resistance 1 MΩ or more?	Repair the poor contact of ECM connector.	Repair the short circuit to ground in harness between ECM and starter relay connector.

## EC:DTC P0617 STARTER RELAY CIRCUIT HIGH

### DTC DETECTING CONDITION:

- Immediately at fault recognition
- GENERAL DESCRIPTION <Ref. to GD(H6DO)-185, DTC P0617 STARTER RELAY CIRCUIT HIGH, Diagnostic Trouble Code (DTC) Detecting Criteria.>

### TROUBLE SYMPTOM:

Failure of engine to start

### CAUTION:

After servicing or replacing faulty parts, perform Clear Memory Mode <Ref. to EN(H6DO)(diag)-62, OPERATION, Clear Memory Mode.>, and Inspection Mode <Ref. to EN(H6DO)(diag)-47, PROCEDURE, Inspection Mode.>.

### WIRING DIAGRAM:

Engine electrical system <Ref. to WI-32, Engine Electrical System.>

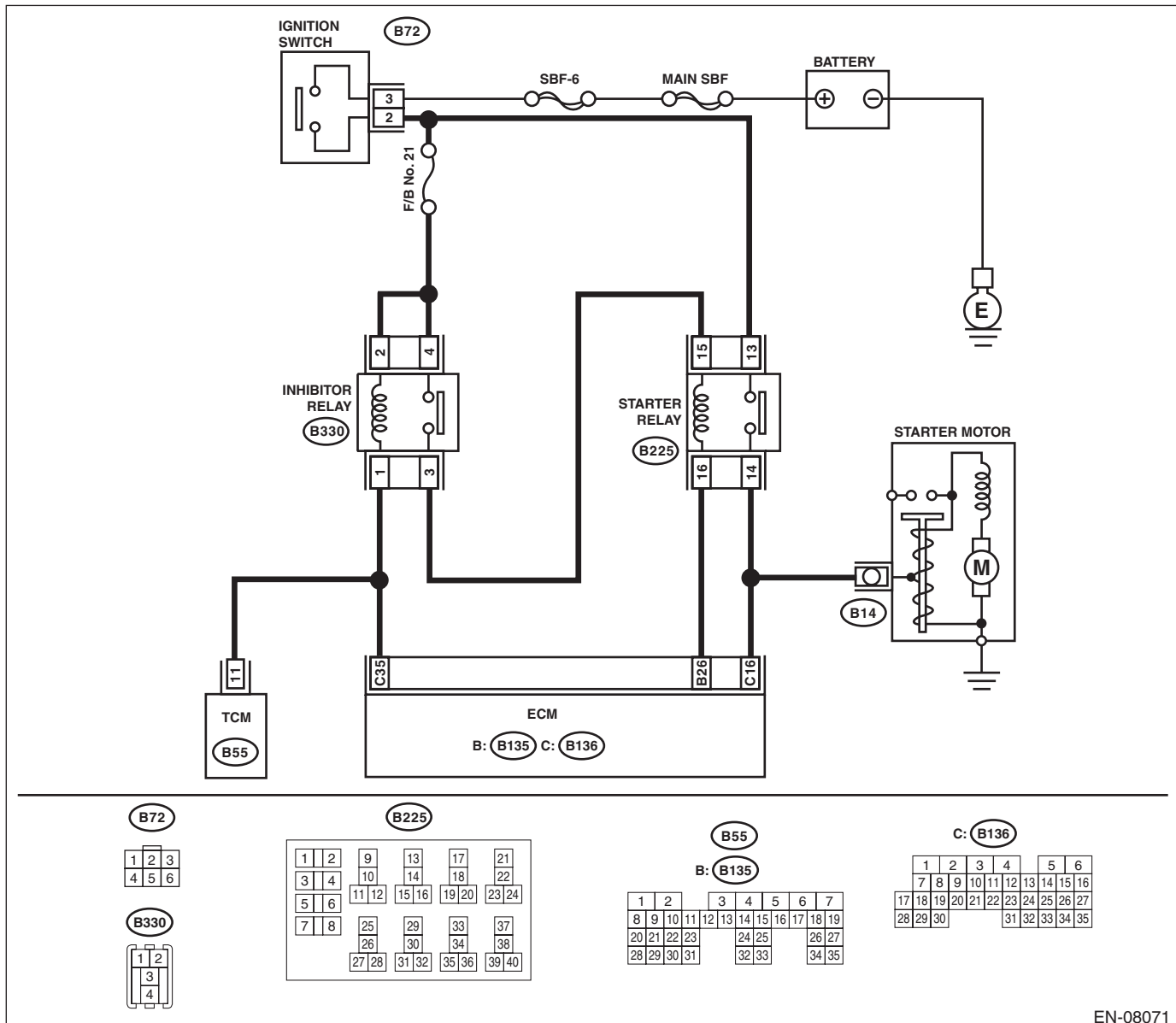

EN-08071

# Diagnostic Procedure with Diagnostic Trouble Code (DTC)

ENGINE (DIAGNOSTICS)

Step	Check	Yes	No
<b>1</b> <b>CHECK FOR ANY OTHER DTC ON DISPLAY.</b>	Is any other DTC displayed?	Check the appropriate DTC using the "List of Diagnostic Trouble Code (DTC)". <Ref. to EN(H6DO)(diag)-89, List of Diagnostic Trouble Code (DTC).>	Go to step 2.
<b>2</b> <b>CHECK HARNESS BETWEEN ECM AND STARTER RELAY CONNECTOR.</b> 1) Turn the ignition switch to OFF. 2) Disconnect the connector from ECM. 3) Turn the ignition switch to ON. 4) Measure the voltage between ECM and chassis ground. <b>Connector &amp; terminal</b> <b>(B136) No. 16 (+) — Chassis ground (-):</b>	Is the voltage 10 V or more?	Repair the short circuit to power supply in harness between ECM and starter relay connector.	Repair the poor contact of ECM connector.

## ED:DTC P062F INTERNAL CONTROL MODULE EEPROM ERROR

NOTE:

For the diagnostic procedure, refer to DTC P0606. <Ref. to EN(H6DO)(diag)-273, DTC P0606 CONTROL MODULE PROCESSOR, Diagnostic Procedure with Diagnostic Trouble Code (DTC).>

## EE:DTC P0700 TRANSMISSION CONTROL SYSTEM (MIL REQUEST)

NOTE:

For the diagnostic procedure, refer to AT section. <Ref. to 5AT(diag)-2, Basic Diagnostic Procedure.>

## EF:DTC P1160 RETURN SPRING FAILURE

NOTE:

For the diagnostic procedure, refer to DTC P2101. <Ref. to EN(H6DO)(diag)-328, DTC P2101 THROTTLE ACTUATOR CONTROL MOTOR CIRCUIT RANGE/PERFORMANCE, Diagnostic Procedure with Diagnostic Trouble Code (DTC).>

# Diagnostic Procedure with Diagnostic Trouble Code (DTC)

ENGINE (DIAGNOSTICS)

## EG:DTC P1449 EVAPORATIVE EMISSION CONT. SYS. AIR FILTER CLOG

### DTC DETECTING CONDITION:

- Detected when two consecutive driving cycles with fault occur.
- GENERAL DESCRIPTION <Ref. to GD(H6DO)-190, DTC P1449 EVAPORATIVE EMISSION CONT. SYS. AIR FILTER CLOG, Diagnostic Trouble Code (DTC) Detecting Criteria.>

### CAUTION:

After servicing or replacing faulty parts, perform Clear Memory Mode <Ref. to EN(H6DO)(diag)-62, OPERATION, Clear Memory Mode.>, and Inspection Mode <Ref. to EN(H6DO)(diag)-47, PROCEDURE, Inspection Mode.>.

Step	Check	Yes	No
1 <b>CHECK FOR ANY OTHER DTC ON DISPLAY.</b>	Is any other DTC displayed?	Check the appropriate DTC using the "List of Diagnostic Trouble Code (DTC)". <Ref. to EN(H6DO)(diag)-89, List of Diagnostic Trouble Code (DTC).>	Go to step 2.
2 <b>CHECK DRAIN TUBE OF LEAK CHECK VALVE ASSEMBLY.</b>	Is the drain tube of leak check valve assembly clogged?	Replace the drain tube of leak check valve assembly. <Ref. to EC(H6DO)-12, Leak Check Valve Assembly.>	Go to step 3.
3 <b>CHECK HOSES BETWEEN LEAK CHECK VALVE ASSEMBLY AND DRAIN FILTER.</b>	Are the hoses between the leak check valve assembly and drain filter clogged?	Replace the hose between leak check valve assembly and drain filter. <Ref. to EC(H6DO)-6, Canister.> <Ref. to EC(H6DO)-11, Drain Filter.>	Go to step 4.
4 <b>CHECK DRAIN FILTER.</b>	Is the drain filter clogged?	Replace the drain filter. <Ref. to EC(H6DO)-11, Drain Filter.>	Replace the leak check valve assembly. <Ref. to EC(H6DO)-12, Leak Check Valve Assembly.>

# Diagnostic Procedure with Diagnostic Trouble Code (DTC)

ENGINE (DIAGNOSTICS)

## EH:DTC P1451 EVAPORATIVE EMISSION CONT. SYS.

### DTC DETECTING CONDITION:

- Detected when two consecutive driving cycles with fault occur.
- GENERAL DESCRIPTION <Ref. to GD(H6DO)-192, DTC P1451 EVAPORATIVE EMISSION CONT. SYS., Diagnostic Trouble Code (DTC) Detecting Criteria.>

### CAUTION:

After servicing or replacing faulty parts, perform Clear Memory Mode <Ref. to EN(H6DO)(diag)-62, OPERATION, Clear Memory Mode.>, and Inspection Mode <Ref. to EN(H6DO)(diag)-47, PROCEDURE, Inspection Mode.>.

Step	Check	Yes	No
<b>1</b> <b>CHECK DRAIN TUBE BETWEEN CANISTER AND LEAK CHECK VALVE ASSEMBLY.</b>	Is the drain tube between canister and leak check valve assembly clogged?	Replace the drain tube between the canister and leak check valve assembly. <Ref. to EC(H6DO)-6, Canister.>	Go to step 2.
<b>2</b> <b>CHECK HOSES BETWEEN CANISTER AND FUEL TANK.</b>	Are the hoses between the canister and fuel tank clogged?	Replace the hoses between the canister and fuel tank. <Ref. to EC(H6DO)-6, Canister.> <Ref. to FU(H6DO)-60, Fuel Tank.>	Replace the canister. <Ref. to EC(H6DO)-6, Canister.> After the operation is complete, go to the next step. Go to step 3.
<b>3</b> <b>CHECK EVAPORATIVE EMISSION CONTROL SYSTEM.</b> Perform drive cycle I. <Ref. to EN(H6DO)(diag)-59, DRIVE CYCLE H, PROCEDURE, Drive Cycle.>	Is DTC P1451 displayed on the display?	Replace the leak check valve assembly. <Ref. to EC(H6DO)-12, Leak Check Valve Assembly.>	End.

## **EI: DTC P1492 EGR SOLENOID VALVE SIGNAL #1 CIRCUIT MALFUNCTION (LOW INPUT)**

**NOTE:**

For the diagnostic procedure, refer to DTC P1498. <Ref. to EN(H6DO)(diag)-282, DTC P1498 EGR SOLENOID VALVE SIGNAL #4 CIRCUIT MALFUNCTION (LOW INPUT), Diagnostic Procedure with Diagnostic Trouble Code (DTC).>

## **EJ: DTC P1493 EGR SOLENOID VALVE SIGNAL #1 CIRCUIT MALFUNCTION (HIGH INPUT)**

**NOTE:**

For the diagnostic procedure, refer to DTC P1499. <Ref. to EN(H6DO)(diag)-285, DTC P1499 EGR SOLENOID VALVE SIGNAL #4 CIRCUIT MALFUNCTION (HIGH INPUT), Diagnostic Procedure with Diagnostic Trouble Code (DTC).>

## **EK: DTC P1494 EGR SOLENOID VALVE SIGNAL #2 CIRCUIT MALFUNCTION (LOW INPUT)**

**NOTE:**

For the diagnostic procedure, refer to DTC P1498. <Ref. to EN(H6DO)(diag)-282, DTC P1498 EGR SOLENOID VALVE SIGNAL #4 CIRCUIT MALFUNCTION (LOW INPUT), Diagnostic Procedure with Diagnostic Trouble Code (DTC).>

## **EL: DTC P1495 EGR SOLENOID VALVE SIGNAL #2 CIRCUIT MALFUNCTION (HIGH INPUT)**

**NOTE:**

For the diagnostic procedure, refer to DTC P1499. <Ref. to EN(H6DO)(diag)-285, DTC P1499 EGR SOLENOID VALVE SIGNAL #4 CIRCUIT MALFUNCTION (HIGH INPUT), Diagnostic Procedure with Diagnostic Trouble Code (DTC).>

## **EM: DTC P1496 EGR SOLENOID VALVE SIGNAL #3 CIRCUIT MALFUNCTION (LOW INPUT)**

**NOTE:**

For the diagnostic procedure, refer to DTC P1498. <Ref. to EN(H6DO)(diag)-282, DTC P1498 EGR SOLENOID VALVE SIGNAL #4 CIRCUIT MALFUNCTION (LOW INPUT), Diagnostic Procedure with Diagnostic Trouble Code (DTC).>

## **EN: DTC P1497 EGR SOLENOID VALVE SIGNAL #3 CIRCUIT MALFUNCTION (HIGH INPUT)**

**NOTE:**

For the diagnostic procedure, refer to DTC P1499. <Ref. to EN(H6DO)(diag)-285, DTC P1499 EGR SOLENOID VALVE SIGNAL #4 CIRCUIT MALFUNCTION (HIGH INPUT), Diagnostic Procedure with Diagnostic Trouble Code (DTC).>

## Diagnostic Procedure with Diagnostic Trouble Code (DTC)

ENGINE (DIAGNOSTICS)

---

### **EO:DTC P1498 EGR SOLENOID VALVE SIGNAL #4 CIRCUIT MALFUNCTION (LOW INPUT)**

#### **DTC DETECTING CONDITION:**

- Immediately at fault recognition
- GENERAL DESCRIPTION <Ref. to GD(H6DO)-193, DTC P1492 EGR SOLENOID VALVE SIGNAL #1 CIRCUIT MALFUNCTION (LOW INPUT), Diagnostic Trouble Code (DTC) Detecting Criteria.> <Ref. to GD(H6DO)-197, DTC P1494 EGR SOLENOID VALVE SIGNAL #2 CIRCUIT MALFUNCTION (LOW INPUT), Diagnostic Trouble Code (DTC) Detecting Criteria.> <Ref. to GD(H6DO)-197, DTC P1496 EGR SOLENOID VALVE SIGNAL #3 CIRCUIT MALFUNCTION (LOW INPUT), Diagnostic Trouble Code (DTC) Detecting Criteria.> <Ref. to GD(H6DO)-197, DTC P1498 EGR SOLENOID VALVE SIGNAL #4 CIRCUIT MALFUNCTION (LOW INPUT), Diagnostic Trouble Code (DTC) Detecting Criteria.>

#### **TROUBLE SYMPTOM:**

- Improper idling
- Poor driving performance
- Engine breathing

#### **CAUTION:**

**After servicing or replacing faulty parts, perform Clear Memory Mode <Ref. to EN(H6DO)(diag)-62, OPERATION, Clear Memory Mode.>, and Inspection Mode <Ref. to EN(H6DO)(diag)-47, PROCEDURE, Inspection Mode.>.**



# Diagnostic Procedure with Diagnostic Trouble Code (DTC)

ENGINE (DIAGNOSTICS)

## WIRING DIAGRAM:

Engine electrical system <Ref. to WI-32, Engine Electrical System.>

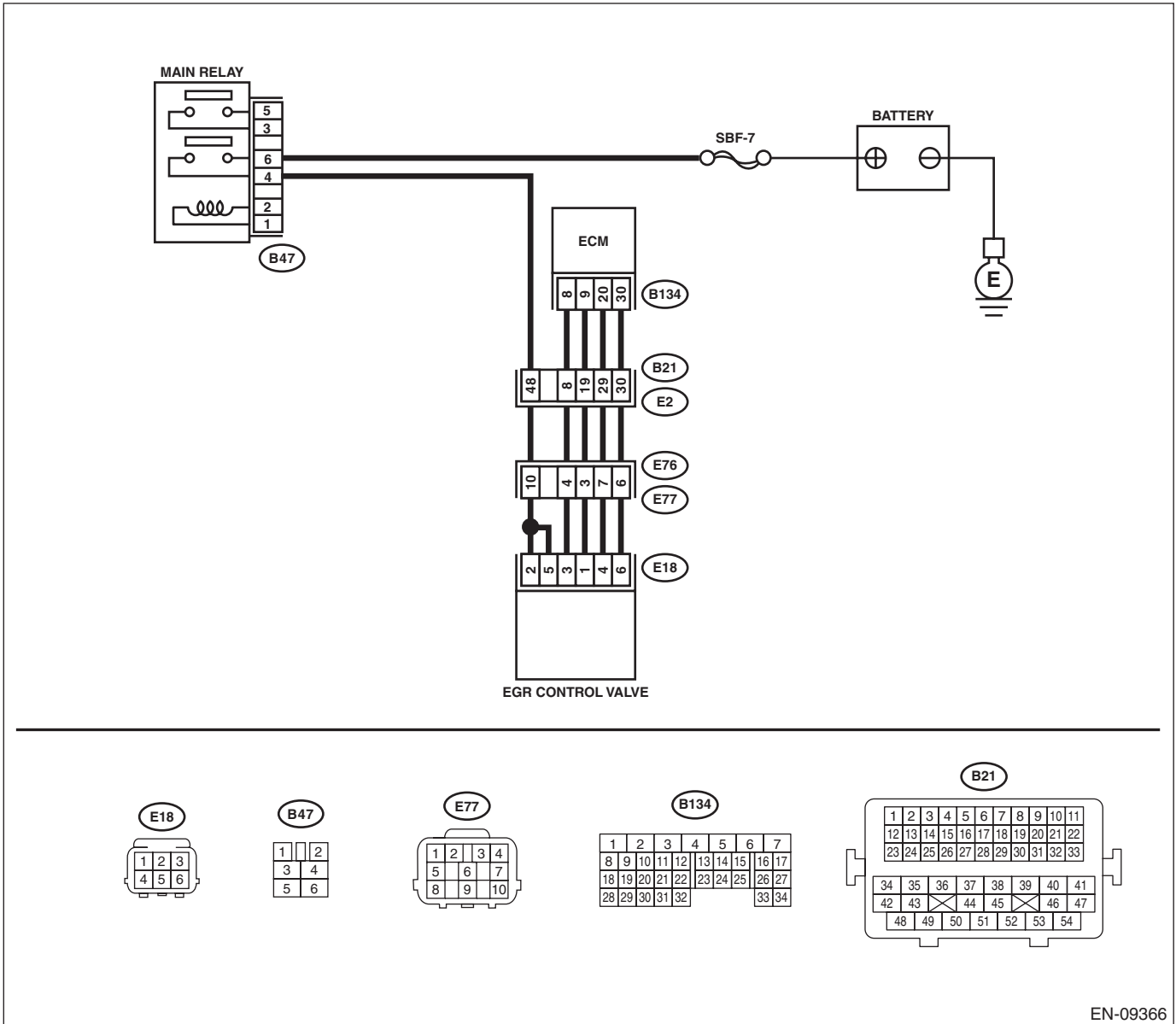

EN-09366

# Diagnostic Procedure with Diagnostic Trouble Code (DTC)

## ENGINE (DIAGNOSTICS)

Step	Check	Yes	No
<b>1 CHECK POWER SUPPLY TO EGR CONTROL VALVE.</b> 1) Turn the ignition switch to OFF. 2) Disconnect the connector from the EGR control valve. 3) Turn the ignition switch to ON. 4) Measure the voltage between EGR control valve connector and engine ground. <b>Connector &amp; terminal</b> <b>(E18) No. 2 (+) — Engine ground (-):</b> <b>(E18) No. 5 (+) — Engine ground (-):</b>	Is the voltage 10 V or more?	Go to step 2.	Repair the harness and connector. <b>NOTE:</b> In this case, repair the following item: • Open circuit in harness between EGR control valve connector and main relay connector • Poor contact of coupling connector
<b>2 CHECK HARNESS BETWEEN ECM AND EGR CONTROL VALVE CONNECTOR.</b> 1) Turn the ignition switch to OFF. 2) Disconnect the connector from ECM. 3) Measure the resistance of harness between ECM and EGR control valve connector. <b>Connector &amp; terminal</b> <b>DTC P1492; (B134) No. 8 — (E18) No. 3:</b> <b>DTC P1494; (B134) No. 9 — (E18) No. 1:</b> <b>DTC P1496; (B134) No. 20 — (E18) No. 4:</b> <b>DTC P1498; (B134) No. 30 — (E18) No. 6:</b>	Is the resistance less than 1 Ω?	Go to step 3.	Repair the harness and connector. <b>NOTE:</b> In this case, repair the following item: • Open circuit of harness between ECM and EGR control valve connector • Poor contact of coupling connector
<b>3 CHECK HARNESS BETWEEN ECM AND EGR CONTROL VALVE CONNECTOR.</b> 1) Disconnect the connector from ECM. 2) Measure the resistance between ECM and chassis ground. <b>Connector &amp; terminal</b> <b>DTC P1492; (B134) No. 8 — Chassis ground:</b> <b>DTC P1494; (B134) No. 9 — Chassis ground:</b> <b>DTC P1496; (B134) No. 20 — Chassis ground:</b> <b>DTC P1498; (B134) No. 30 — Chassis ground:</b>	Is the resistance 1 MΩ or more?	Go to step 4.	Repair the ground short in harness between ECM and EGR control valve connector.
<b>4 CHECK FOR POOR CONTACT.</b> Check poor contact of ECM and EGR control valve connectors.	Is there poor contact in ECM or EGR control valve connector?	Repair the poor contact of ECM or EGR control valve connector.	Replace EGR control valve. <Ref. to FU(H6DO)-41, EGR Valve.>

## **EP:DTC P1499 EGR SOLENOID VALVE SIGNAL #4 CIRCUIT MALFUNCTION (HIGH INPUT)**

### **DTC DETECTING CONDITION:**

- Immediately at fault recognition
- GENERAL DESCRIPTION <Ref. to GD(H6DO)-195, DTC P1493 EGR SOLENOID VALVE SIGNAL #1 CIRCUIT MALFUNCTION (HIGH INPUT), Diagnostic Trouble Code (DTC) Detecting Criteria.> <Ref. to GD(H6DO)-197, DTC P1495 EGR SOLENOID VALVE SIGNAL #2 CIRCUIT MALFUNCTION (HIGH INPUT), Diagnostic Trouble Code (DTC) Detecting Criteria.> <Ref. to GD(H6DO)-197, DTC P1497 EGR SOLENOID VALVE SIGNAL #3 CIRCUIT MALFUNCTION (HIGH INPUT), Diagnostic Trouble Code (DTC) Detecting Criteria.> <Ref. to GD(H6DO)-197, DTC P1499 EGR SOLENOID VALVE SIGNAL #4 CIRCUIT MALFUNCTION (HIGH INPUT), Diagnostic Trouble Code (DTC) Detecting Criteria.>

### **TROUBLE SYMPTOM:**

- Improper idling
- Poor driving performance
- Engine breathing

### **CAUTION:**

**After servicing or replacing faulty parts, perform Clear Memory Mode <Ref. to EN(H6DO)(diag)-62, OPERATION, Clear Memory Mode.>, and Inspection Mode <Ref. to EN(H6DO)(diag)-47, PROCEDURE, Inspection Mode.>.**

# Diagnostic Procedure with Diagnostic Trouble Code (DTC)

ENGINE (DIAGNOSTICS)

## WIRING DIAGRAM:

Engine electrical system <Ref. to WI-32, Engine Electrical System.>

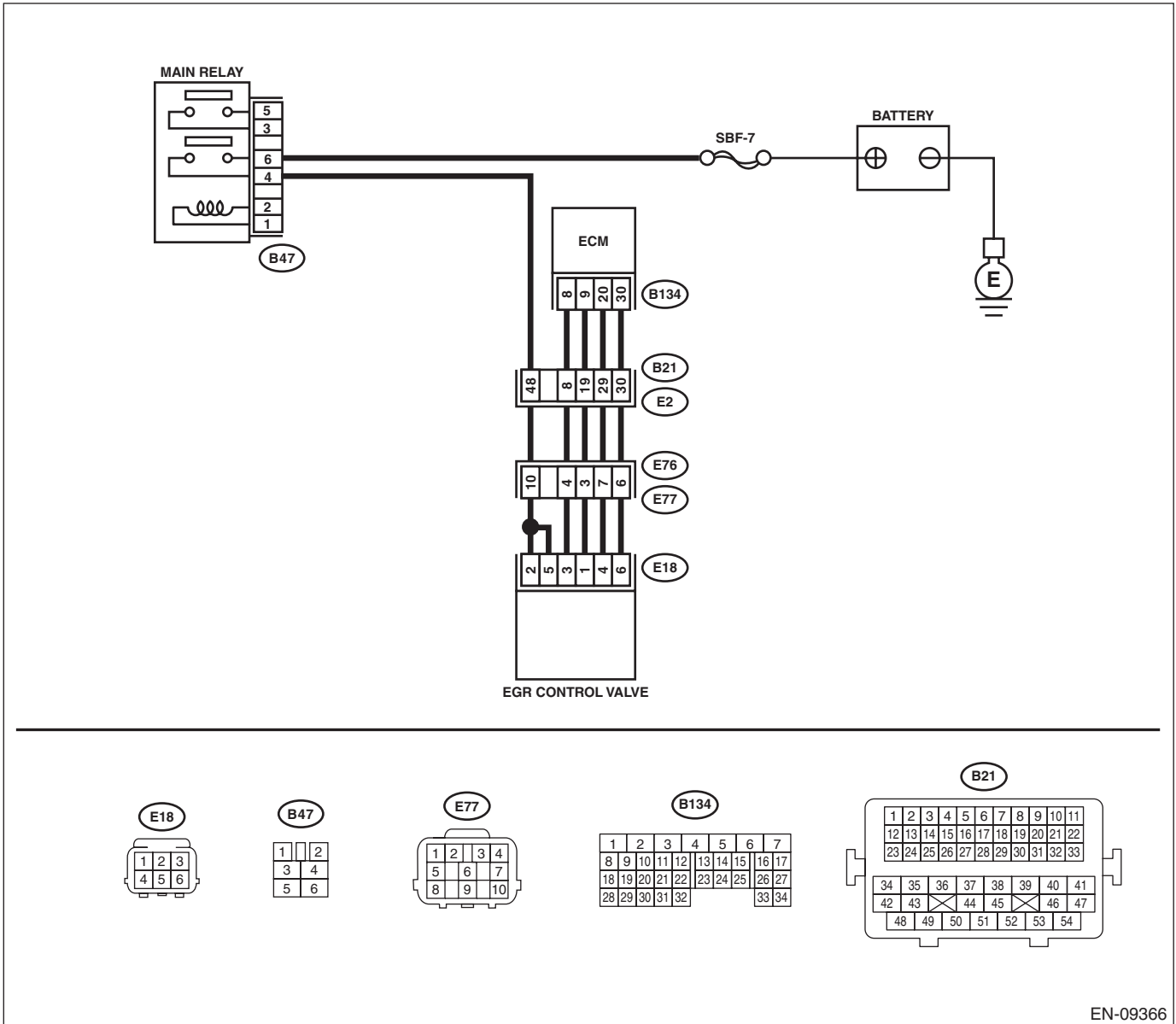

EN-09366

# Diagnostic Procedure with Diagnostic Trouble Code (DTC)

ENGINE (DIAGNOSTICS)

	Step	Check	Yes	No
1	<p><b>CHECK HARNESS BETWEEN ECM AND EGR CONTROL VALVE CONNECTOR.</b></p> <p>1) Turn the ignition switch to OFF.                      2) Disconnect the connector from ECM and EGR control valve.                      3) Turn the ignition switch to ON.                      4) Measure the voltage between ECM and chassis ground.</p> <p><b>Connector &amp; terminal</b>  <b>DTC P1493; (B134) No. 8 (+) — Chassis ground (-):</b>  <b>DTC P1495; (B134) No. 9 (+) — Chassis ground (-):</b>  <b>DTC P1497; (B134) No. 20 (+) — Chassis ground (-):</b>  <b>DTC P1499; (B134) No. 30 (+) — Chassis ground (-):</b></p>	Is the voltage 10 V or more?	Repair the short circuit to power in the harness between the ECM and EGR control valve connector.	Go to step 2.
2	<p><b>CHECK EGR CONTROL VALVE.</b></p> <p>Measure the resistance between EGR control valve terminals.</p> <p><b>Terminals</b>  <b>DTC P1493; No. 2 — No. 3:</b>  <b>DTC P1495; No. 2 — No. 1:</b>  <b>DTC P1497; No. 5 — No. 4:</b>  <b>DTC P1499; No. 5 — No. 6:</b></p>	Is the resistance 20 Ω or more?	Repair the poor contact of ECM connector.	Replace EGR control valve. <Ref. to FU(H6DO)-41, EGR Valve.>

# Diagnostic Procedure with Diagnostic Trouble Code (DTC)

ENGINE (DIAGNOSTICS)

## EQ:DTC P2088 INTAKE CAMSHAFT POSITION ACTUATOR CONTROL CIRCUIT LOW (BANK 1)

### DTC DETECTING CONDITION:

- Immediately at fault recognition
- GENERAL DESCRIPTION <Ref. to GD(H6DO)-199, DTC P2088 INTAKE CAMSHAFT POSITION ACTUATOR CONTROL CIRCUIT LOW (BANK 1), Diagnostic Trouble Code (DTC) Detecting Criteria.>

### TROUBLE SYMPTOM:

Improper idling

### CAUTION:

After servicing or replacing faulty parts, perform Clear Memory Mode <Ref. to EN(H6DO)(diag)-62, OPERATION, Clear Memory Mode.>, and Inspection Mode <Ref. to EN(H6DO)(diag)-47, PROCEDURE, Inspection Mode.>.

### WIRING DIAGRAM:

Engine electrical system <Ref. to WI-32, Engine Electrical System.>

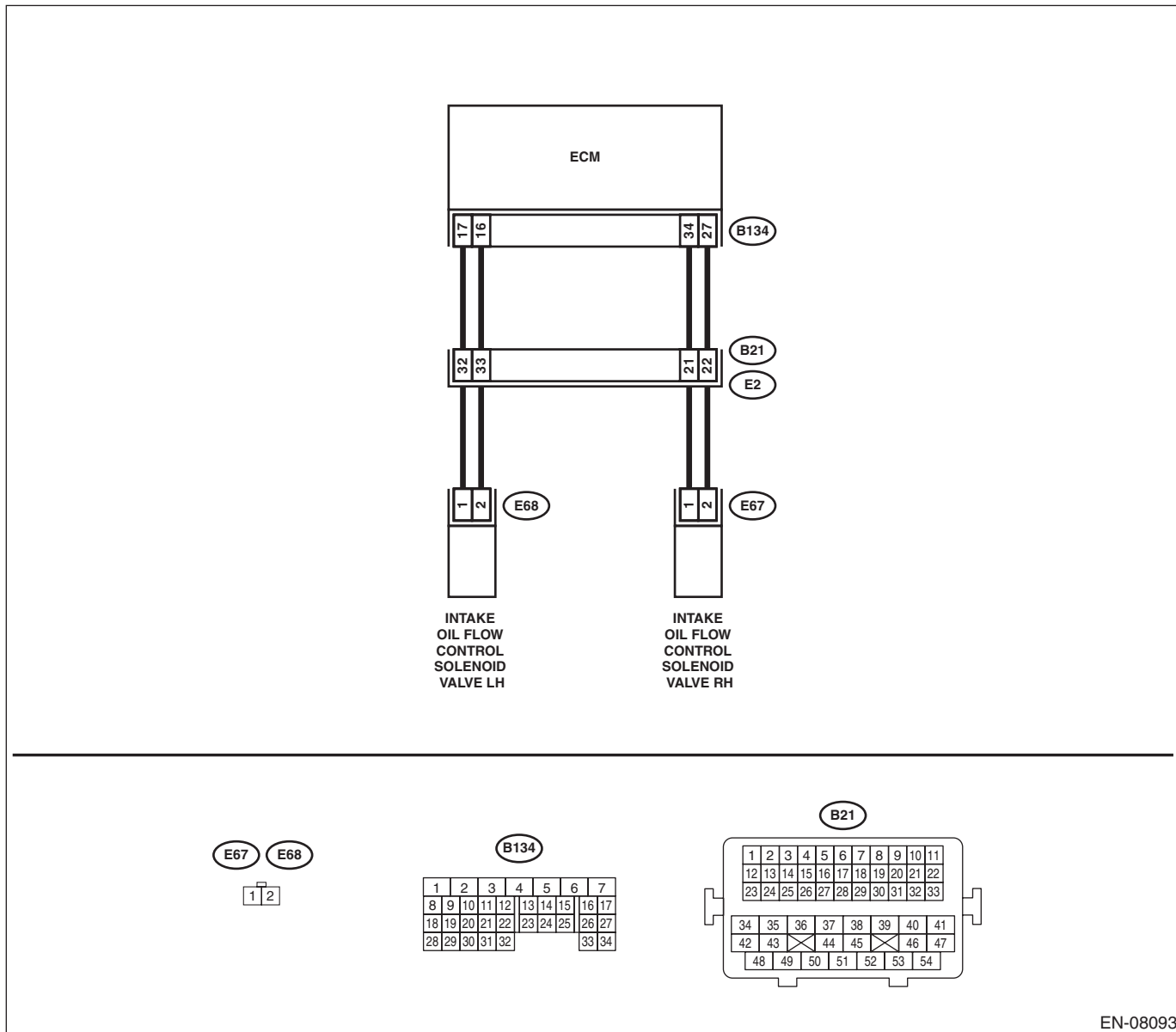

EN-08093

# Diagnostic Procedure with Diagnostic Trouble Code (DTC)

ENGINE (DIAGNOSTICS)

Step	Check	Yes	No
<p><b>1</b>     <b>CHECK HARNESS BETWEEN ECM AND OIL FLOW CONTROL SOLENOID VALVE RH CONNECTOR.</b>            1) Turn the ignition switch to OFF.            2) Disconnect the connectors from ECM and oil flow control solenoid valve RH.            3) Measure the resistance of harness between ECM and oil flow control solenoid valve RH connector.</p> <p><b>Connector &amp; terminal</b>  <b>(B134) No. 34 — (E67) No. 1:</b>  <b>(B134) No. 27 — (E67) No. 2:</b></p>	<p>Is the resistance less than 1 Ω?</p>	<p>Go to step 2.</p>	<p>Repair the harness and connector.</p> <p>NOTE:            In this case, repair the following item:</p> <ul style="list-style-type: none"> <li>• Open circuit in harness between ECM and oil flow control solenoid valve RH connector</li> <li>• Poor contact of coupling connector</li> </ul>
<p><b>2</b>     <b>CHECK HARNESS BETWEEN ECM AND OIL FLOW CONTROL SOLENOID VALVE RH CONNECTOR.</b>            Measure the resistance between ECM and chassis ground.</p> <p><b>Connector &amp; terminal</b>  <b>(B134) No. 34 — Chassis ground:</b>  <b>(B134) No. 27 — Chassis ground:</b></p>	<p>Is the resistance 1 MΩ or more?</p>	<p>Go to step 3.</p>	<p>Repair the short circuit to ground in harness between ECM and oil flow control solenoid valve RH connector.</p>
<p><b>3</b>     <b>CHECK OIL FLOW CONTROL SOLENOID VALVE.</b>            Measure the resistance between oil flow control solenoid valve terminals.</p> <p><b>Terminals</b>  <b>No. 1 — No. 2:</b></p>	<p>Is the resistance 6 — 12 Ω?</p>	<p>Repair the poor contact of ECM and oil flow control solenoid valve RH connector.</p>	<p>Replace the oil flow control solenoid valve RH.            &lt;Ref. to FU(H6DO)-45, Oil Flow Control Solenoid Valve.&gt;</p>

# Diagnostic Procedure with Diagnostic Trouble Code (DTC)

ENGINE (DIAGNOSTICS)

## ER:DTC P2089 INTAKE CAMSHAFT POSITION ACTUATOR CONTROL CIRCUIT HIGH (BANK 1)

### DTC DETECTING CONDITION:

- Immediately at fault recognition
- GENERAL DESCRIPTION <Ref. to GD(H6DO)-200, DTC P2089 INTAKE CAMSHAFT POSITION ACTUATOR CONTROL CIRCUIT HIGH (BANK 1), Diagnostic Trouble Code (DTC) Detecting Criteria.>

### TROUBLE SYMPTOM:

Improper idling

### CAUTION:

After servicing or replacing faulty parts, perform Clear Memory Mode <Ref. to EN(H6DO)(diag)-62, OPERATION, Clear Memory Mode.>, and Inspection Mode <Ref. to EN(H6DO)(diag)-47, PROCEDURE, Inspection Mode.>.

### WIRING DIAGRAM:

Engine electrical system <Ref. to WI-32, Engine Electrical System.>

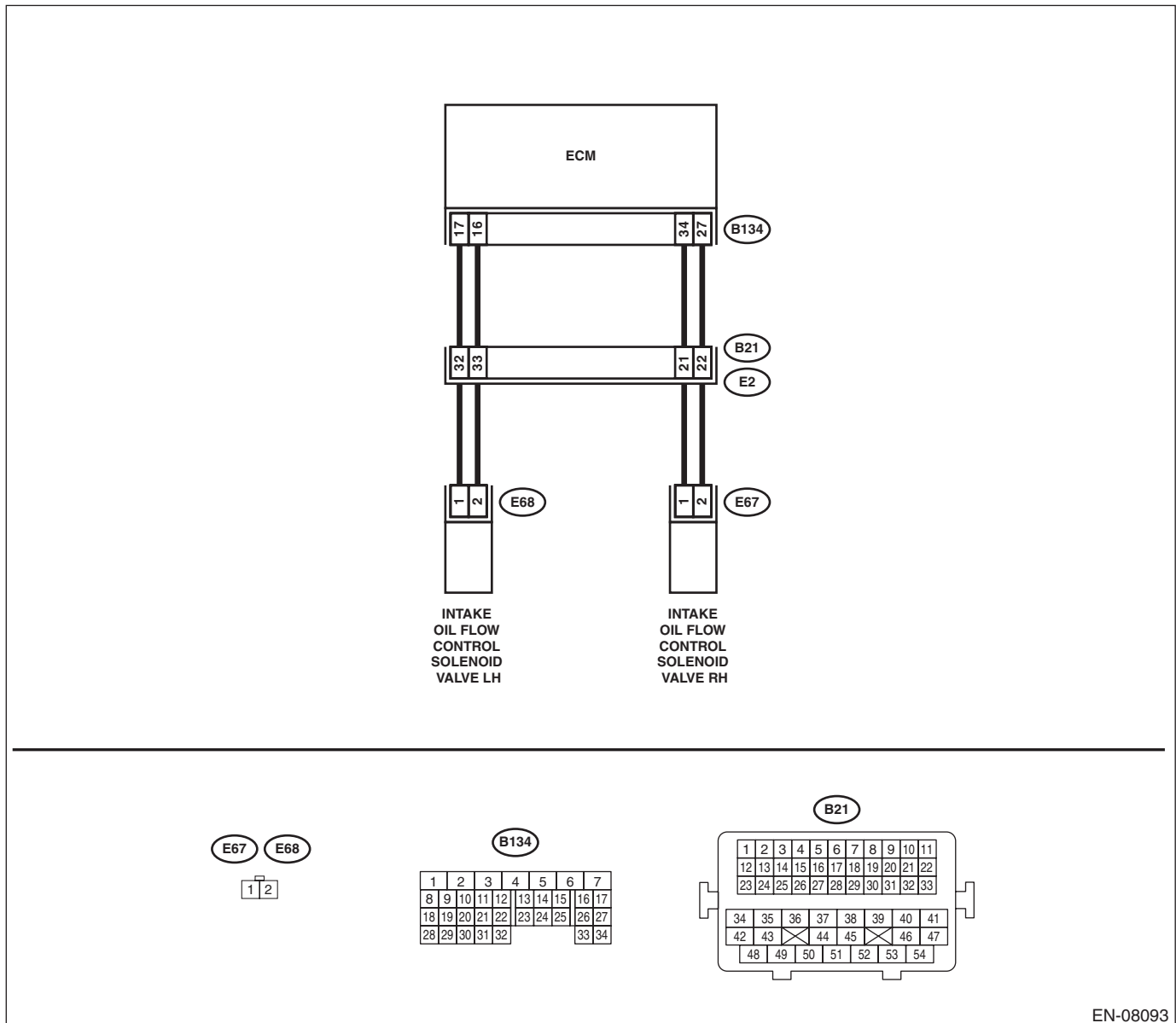

EN-08093



# Diagnostic Procedure with Diagnostic Trouble Code (DTC)

ENGINE (DIAGNOSTICS)

Step	Check	Yes	No
<p><b>1</b>     <b>CHECK HARNESS BETWEEN ECM AND OIL FLOW CONTROL SOLENOID VALVE RH CONNECTOR.</b>            1) Turn the ignition switch to OFF.            2) Disconnect the connectors from ECM and oil flow control solenoid valve RH.            3) Measure the voltage between ECM and chassis ground.  <b>Connector &amp; terminal</b>  <b>(B134) No. 34 (+) — Chassis ground (-):</b>  <b>(B134) No. 27 (+) — Chassis ground (-):</b></p>	<p>Is the voltage less than 1 V?</p>	<p>Go to step 2.</p>	<p>Repair the short circuit to power supply in harness between ECM and oil flow control solenoid valve RH connector.</p>
<p><b>2</b>     <b>CHECK HARNESS BETWEEN ECM AND OIL FLOW CONTROL SOLENOID VALVE RH CONNECTOR.</b>            Measure the resistance of harness between ECM and oil flow control solenoid valve RH connector.  <b>Connector &amp; terminal</b>  <b>(B134) No. 34 — (E67) No. 1:</b>  <b>(B134) No. 27 — (E67) No. 2:</b></p>	<p>Is the resistance less than 1 Ω?</p>	<p>Go to step 3.</p>	<p>Repair the harness and connector.            NOTE:            In this case, repair the following item:            • Open circuit in harness between ECM and oil flow control solenoid valve RH connector            • Poor contact of coupling connector</p>
<p><b>3</b>     <b>CHECK OIL FLOW CONTROL SOLENOID VALVE.</b>            Measure the resistance between oil flow control solenoid valve terminals.  <b>Terminals</b>  <b>No. 1 — No. 2:</b></p>	<p>Is the resistance 6 — 12 Ω?</p>	<p>Repair the poor contact of ECM and oil flow control solenoid valve RH connector.</p>	<p>Replace the oil flow control solenoid valve RH.            &lt;Ref. to FU(H6DO)-45, Oil Flow Control Solenoid Valve.&gt;</p>

# Diagnostic Procedure with Diagnostic Trouble Code (DTC)

ENGINE (DIAGNOSTICS)

## ES:DTC P2090 EXHAUST CAMSHAFT POSITION ACTUATOR CONTROL CIRCUIT LOW (BANK 1)

### DTC DETECTING CONDITION:

- Immediately at fault recognition
- GENERAL DESCRIPTION <Ref. to GD(H6DO)-201, DTC P2090 EXHAUST CAMSHAFT POSITION ACTUATOR CONTROL CIRCUIT LOW (BANK 1), Diagnostic Trouble Code (DTC) Detecting Criteria.>

### TROUBLE SYMPTOM:

Improper idling

### CAUTION:

After servicing or replacing faulty parts, perform Clear Memory Mode <Ref. to EN(H6DO)(diag)-62, OPERATION, Clear Memory Mode.>, and Inspection Mode <Ref. to EN(H6DO)(diag)-47, PROCEDURE, Inspection Mode.>.

### WIRING DIAGRAM:

Engine electrical system <Ref. to WI-32, Engine Electrical System.>

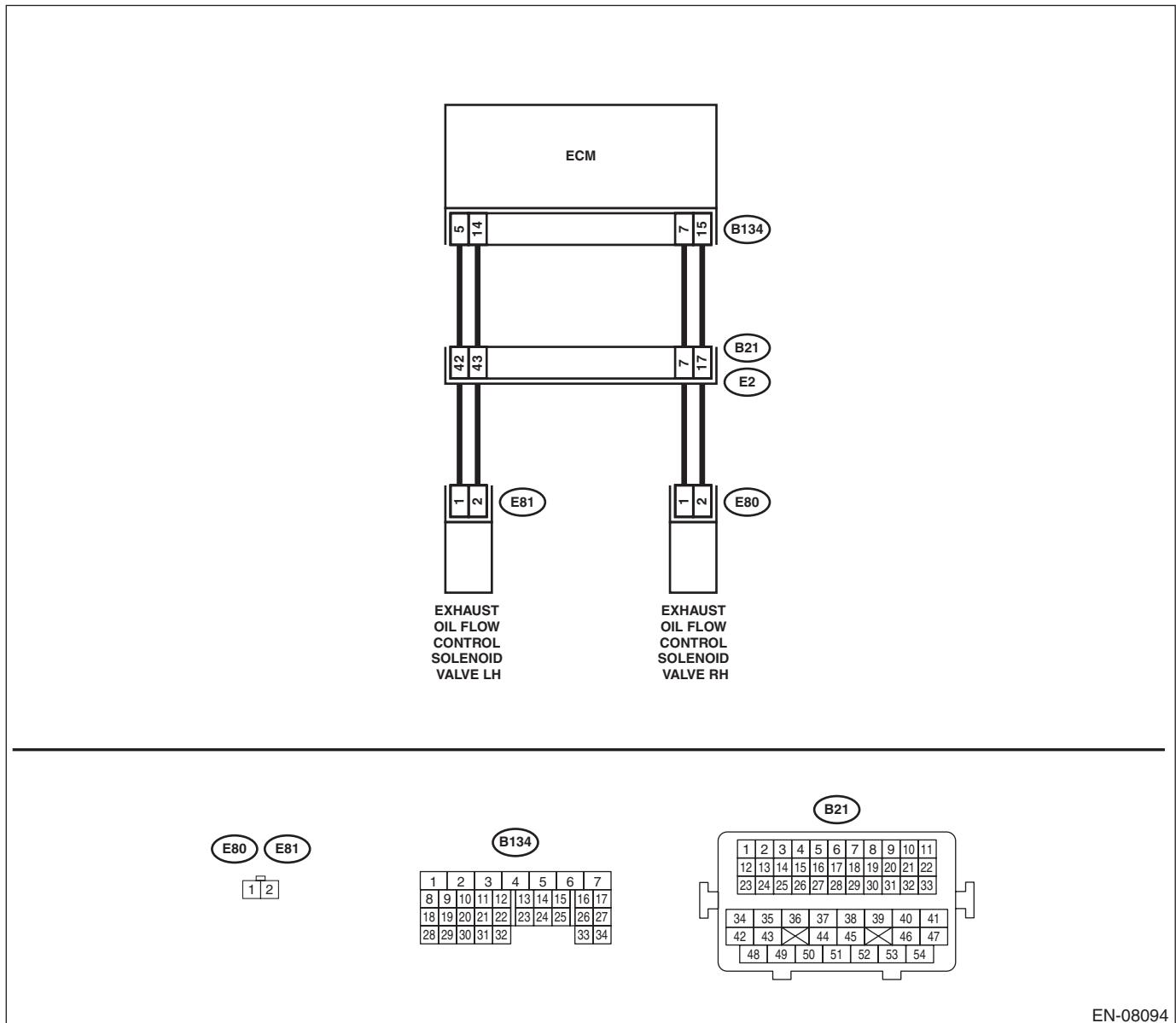

EN-08094

# Diagnostic Procedure with Diagnostic Trouble Code (DTC)

ENGINE (DIAGNOSTICS)

	Step	Check	Yes	No
1	<p><b>CHECK HARNESS BETWEEN ECM AND OIL FLOW CONTROL SOLENOID VALVE RH CONNECTOR.</b></p> <p>1) Turn the ignition switch to OFF.                      2) Disconnect the connectors from ECM and oil flow control solenoid valve RH.                      3) Measure the resistance of harness between ECM and oil flow control solenoid valve RH connector.</p> <p><b>Connector &amp; terminal</b>                      (B134) No. 7 — (E80) No. 1:                      (B134) No. 15 — (E80) No. 2:</p>	Is the resistance less than 1 Ω?	Go to step 2.	<p>Repair the harness and connector.</p> <p>NOTE:                      In this case, repair the following item:</p> <ul style="list-style-type: none"> <li>• Open circuit in harness between ECM and oil flow control solenoid valve RH connector</li> <li>• Poor contact of coupling connector</li> </ul>
2	<p><b>CHECK HARNESS BETWEEN ECM AND OIL FLOW CONTROL SOLENOID VALVE RH CONNECTOR.</b></p> <p>Measure the resistance between ECM and chassis ground.</p> <p><b>Connector &amp; terminal</b>                      (B134) No. 7 — Chassis ground:                      (B134) No. 15 — Chassis ground:</p>	Is the resistance 1 MΩ or more?	Go to step 3.	Repair the short circuit to ground in harness between ECM and oil flow control solenoid valve RH connector.
3	<p><b>CHECK OIL FLOW CONTROL SOLENOID VALVE.</b></p> <p>Measure the resistance between oil flow control solenoid valve terminals.</p> <p><b>Terminals</b>                      No. 1 — No. 2:</p>	Is the resistance 6 — 12 Ω?	Repair the poor contact of ECM and oil flow control solenoid valve RH connector.	Replace the oil flow control solenoid valve RH. <Ref. to FU(H6DO)-45, Oil Flow Control Solenoid Valve.>

# Diagnostic Procedure with Diagnostic Trouble Code (DTC)

ENGINE (DIAGNOSTICS)

## ET:DTC P2091 EXHAUST CAMSHAFT POSITION ACTUATOR CONTROL CIRCUIT HIGH (BANK 1)

### DTC DETECTING CONDITION:

- Immediately at fault recognition
- GENERAL DESCRIPTION <Ref. to GD(H6DO)-202, DTC P2091 EXHAUST CAMSHAFT POSITION ACTUATOR CONTROL CIRCUIT HIGH (BANK 1), Diagnostic Trouble Code (DTC) Detecting Criteria.>

### TROUBLE SYMPTOM:

Improper idling

### CAUTION:

After servicing or replacing faulty parts, perform Clear Memory Mode <Ref. to EN(H6DO)(diag)-62, OPERATION, Clear Memory Mode.>, and Inspection Mode <Ref. to EN(H6DO)(diag)-47, PROCEDURE, Inspection Mode.>.

### WIRING DIAGRAM:

Engine electrical system <Ref. to WI-32, Engine Electrical System.>

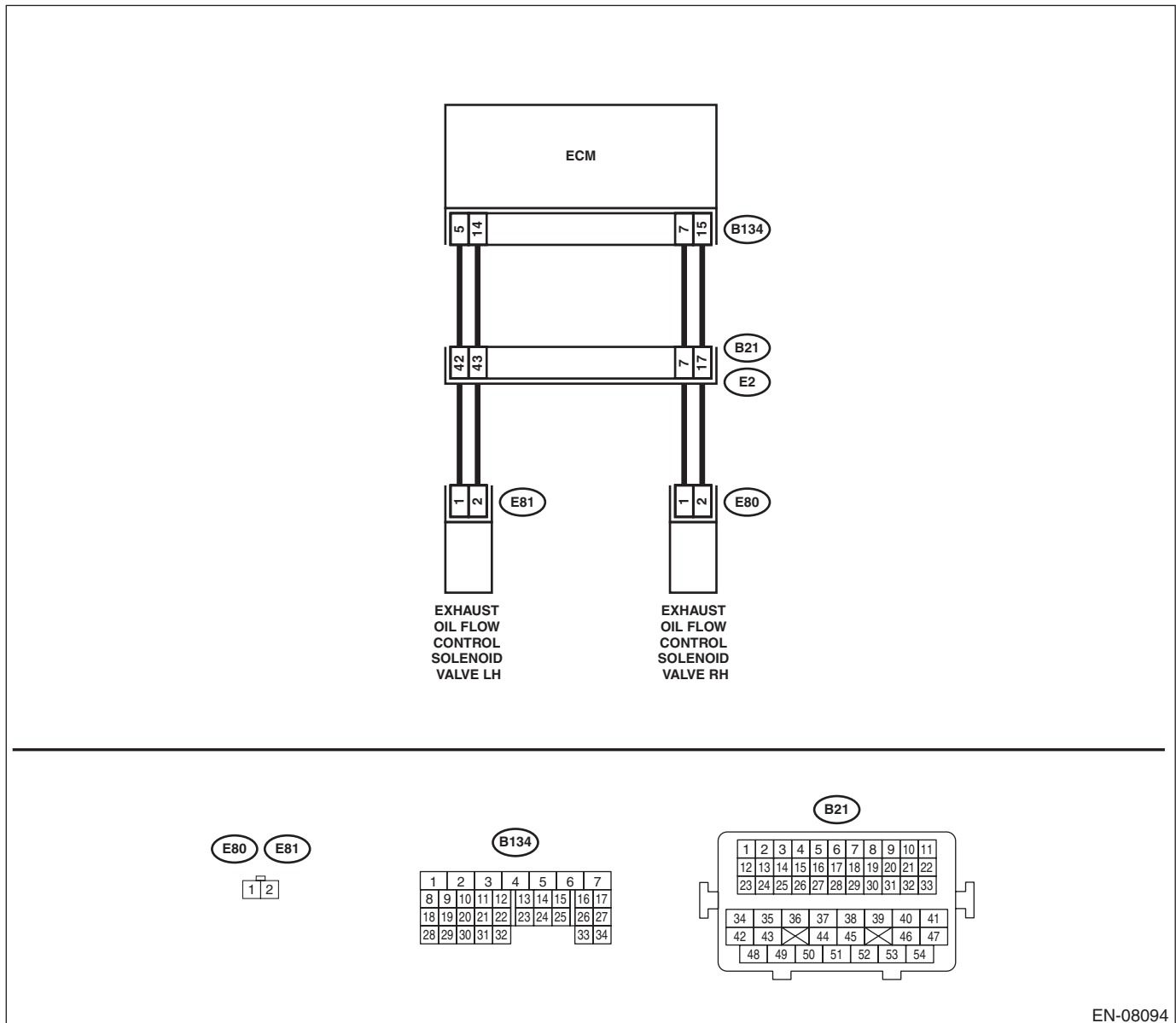

EN-08094

# Diagnostic Procedure with Diagnostic Trouble Code (DTC)

ENGINE (DIAGNOSTICS)

Step	Check	Yes	No
<p><b>1</b>     <b>CHECK HARNESS BETWEEN ECM AND OIL FLOW CONTROL SOLENOID VALVE RH CONNECTOR.</b>            1) Turn the ignition switch to OFF.            2) Disconnect the connectors from ECM and oil flow control solenoid valve RH.            3) Measure the voltage between ECM and chassis ground.  <b>Connector &amp; terminal</b>  <b>(B134) No. 7 (+) — Chassis ground (-):</b>  <b>(B134) No. 15 (+) — Chassis ground (-):</b></p>	<p>Is the voltage less than 1 V?</p>	<p>Go to step 2.</p>	<p>Repair the short circuit to power supply in harness between ECM and oil flow control solenoid valve RH connector.</p>
<p><b>2</b>     <b>CHECK HARNESS BETWEEN ECM AND OIL FLOW CONTROL SOLENOID VALVE RH CONNECTOR.</b>            Measure the resistance of harness between ECM and oil flow control solenoid valve RH connector.  <b>Connector &amp; terminal</b>  <b>(B134) No. 7 — (E80) No. 1:</b>  <b>(B134) No. 15 — (E80) No. 2:</b></p>	<p>Is the resistance less than 1 Ω?</p>	<p>Go to step 3.</p>	<p>Repair the harness and connector.  <b>NOTE:</b>            In this case, repair the following item:            • Open circuit in harness between ECM and oil flow control solenoid valve RH connector            • Poor contact of coupling connector</p>
<p><b>3</b>     <b>CHECK OIL FLOW CONTROL SOLENOID VALVE.</b>            Measure the resistance between oil flow control solenoid valve terminals.  <b>Terminals</b>  <b>No. 1 — No. 2:</b></p>	<p>Is the resistance 6 — 12 Ω?</p>	<p>Repair the poor contact of ECM and oil flow control solenoid valve RH connector.</p>	<p>Replace the oil flow control solenoid valve RH.            &lt;Ref. to FU(H6DO)-45, Oil Flow Control Solenoid Valve.&gt;</p>

# Diagnostic Procedure with Diagnostic Trouble Code (DTC)

ENGINE (DIAGNOSTICS)

## EU:DTC P2092 INTAKE CAMSHAFT POSITION ACTUATOR CONTROL CIRCUIT LOW (BANK 2)

### DTC DETECTING CONDITION:

- Immediately at fault recognition
- GENERAL DESCRIPTION <Ref. to GD(H6DO)-203, DTC P2092 INTAKE CAMSHAFT POSITION ACTUATOR CONTROL CIRCUIT LOW (BANK 2), Diagnostic Trouble Code (DTC) Detecting Criteria.>

### TROUBLE SYMPTOM:

Improper idling

### CAUTION:

After servicing or replacing faulty parts, perform Clear Memory Mode <Ref. to EN(H6DO)(diag)-62, OPERATION, Clear Memory Mode.>, and Inspection Mode <Ref. to EN(H6DO)(diag)-47, PROCEDURE, Inspection Mode.>.

### WIRING DIAGRAM:

Engine electrical system <Ref. to WI-32, Engine Electrical System.>

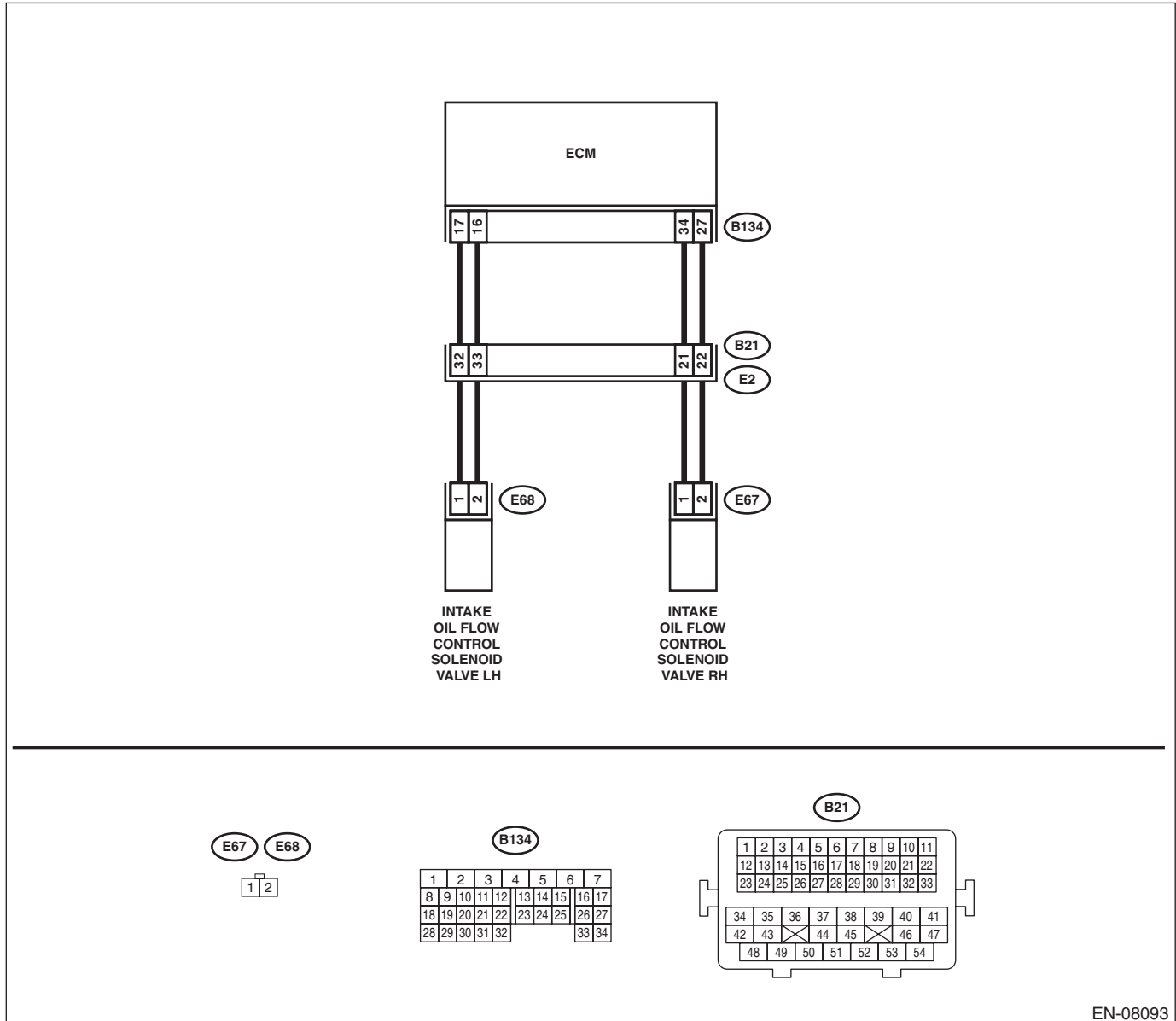

EN-08093

# Diagnostic Procedure with Diagnostic Trouble Code (DTC)

ENGINE (DIAGNOSTICS)

	Step	Check	Yes	No
1	<p><b>CHECK HARNESS BETWEEN ECM AND OIL FLOW CONTROL SOLENOID VALVE LH CONNECTOR.</b></p> <p>1) Turn the ignition switch to OFF. 2) Disconnect the connectors from ECM and oil flow control solenoid valve LH. 3) Measure the resistance of harness between ECM and oil flow control solenoid valve LH connector.</p> <p><b>Connector &amp; terminal</b> <b>(B134) No. 17 — (E68) No. 1:</b> <b>(B134) No. 16 — (E68) No. 2:</b></p>	Is the resistance less than 1 Ω?	Go to step 2.	<p>Repair the harness and connector.</p> <p>NOTE: In this case, repair the following item:</p> <ul style="list-style-type: none"> <li>• Open circuit in harness between ECM and oil flow control solenoid valve LH connector</li> <li>• Poor contact of coupling connector</li> </ul>
2	<p><b>CHECK HARNESS BETWEEN ECM AND OIL FLOW CONTROL SOLENOID VALVE LH CONNECTOR.</b></p> <p>Measure the resistance between ECM and chassis ground.</p> <p><b>Connector &amp; terminal</b> <b>(B134) No. 17 — Chassis ground:</b> <b>(B134) No. 16 — Chassis ground:</b></p>	Is the resistance 1 MΩ or more?	Go to step 3.	Repair the short circuit to ground in harness between ECM and oil flow control solenoid valve LH connector.
3	<p><b>CHECK OIL FLOW CONTROL SOLENOID VALVE.</b></p> <p>Measure the resistance between oil flow control solenoid valve terminals.</p> <p><b>Terminals</b> <b>No. 1 — No. 2:</b></p>	Is the resistance 6 — 12 Ω?	Repair the poor contact of ECM and oil flow control solenoid valve LH connector.	Replace the oil flow control solenoid valve LH. <Ref. to FU(H6DO)-45, Oil Flow Control Solenoid Valve.>

# Diagnostic Procedure with Diagnostic Trouble Code (DTC)

ENGINE (DIAGNOSTICS)

## EV:DTC P2093 INTAKE CAMSHAFT POSITION ACTUATOR CONTROL CIRCUIT HIGH (BANK 2)

### DTC DETECTING CONDITION:

- Immediately at fault recognition
- GENERAL DESCRIPTION <Ref. to GD(H6DO)-203, DTC P2093 INTAKE CAMSHAFT POSITION ACTUATOR CONTROL CIRCUIT HIGH (BANK 2), Diagnostic Trouble Code (DTC) Detecting Criteria.>

### TROUBLE SYMPTOM:

Improper idling

### CAUTION:

After servicing or replacing faulty parts, perform Clear Memory Mode <Ref. to EN(H6DO)(diag)-62, OPERATION, Clear Memory Mode.>, and Inspection Mode <Ref. to EN(H6DO)(diag)-47, PROCEDURE, Inspection Mode.>.

### WIRING DIAGRAM:

Engine electrical system <Ref. to WI-32, Engine Electrical System.>

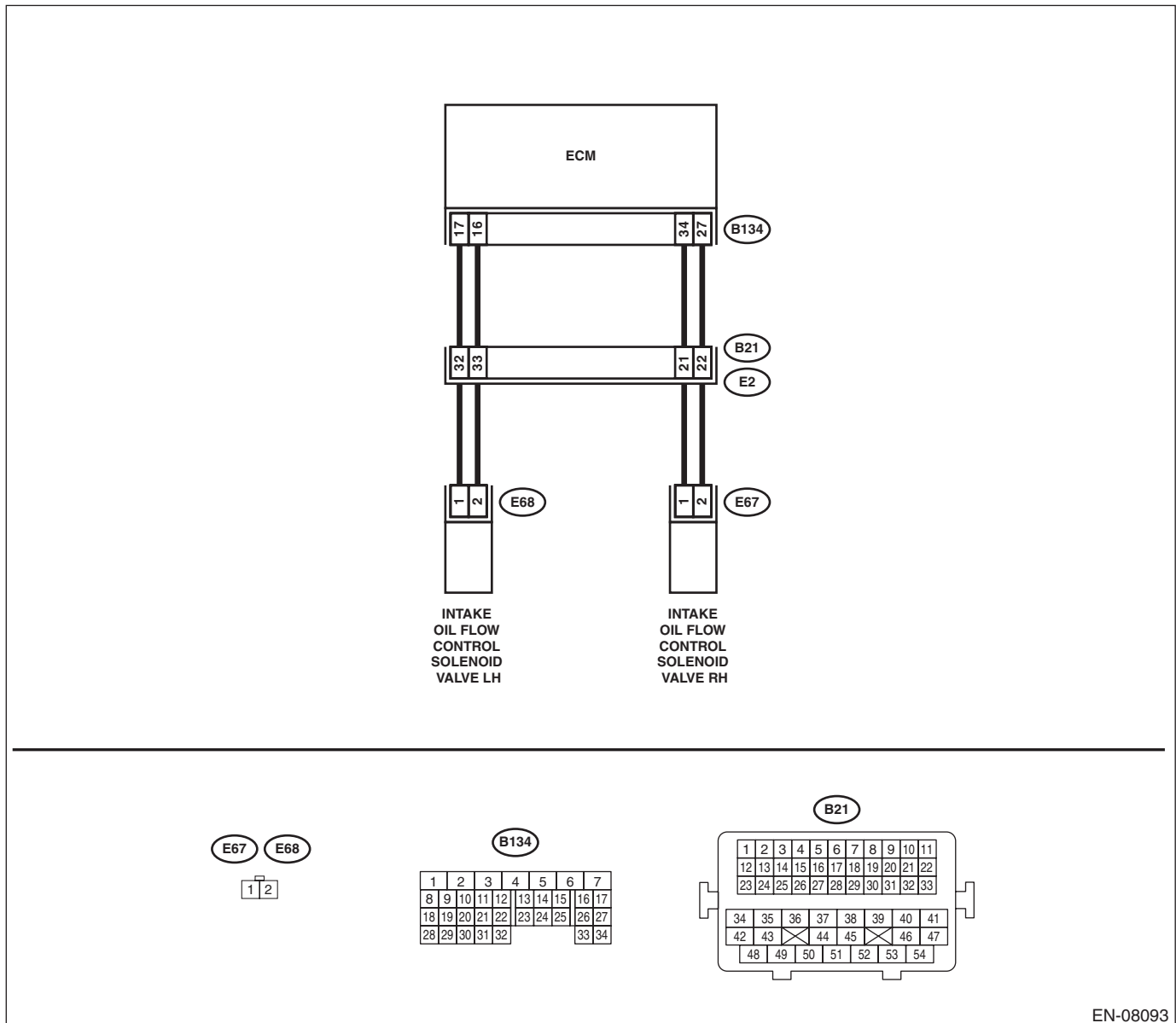

EN-08093



# Diagnostic Procedure with Diagnostic Trouble Code (DTC)

ENGINE (DIAGNOSTICS)

Step	Check	Yes	No
<p><b>1</b>     <b>CHECK HARNESS BETWEEN ECM AND OIL FLOW CONTROL SOLENOID VALVE LH CONNECTOR.</b>            1) Turn the ignition switch to OFF.            2) Disconnect the connectors from ECM and oil flow control solenoid valve LH.            3) Measure the voltage between ECM and chassis ground.  <b>Connector &amp; terminal</b>  <b>(B134) No. 17 (+) — Chassis ground (-):</b>  <b>(B134) No. 16 (+) — Chassis ground (-):</b></p>	<p>Is the voltage less than 1 V?</p>	<p>Go to step 2.</p>	<p>Repair the short circuit to power supply in harness between ECM and oil flow control solenoid valve LH connector.</p>
<p><b>2</b>     <b>CHECK HARNESS BETWEEN ECM AND OIL FLOW CONTROL SOLENOID VALVE LH CONNECTOR.</b>            Measure the resistance of harness between ECM and oil flow control solenoid valve LH connector.  <b>Connector &amp; terminal</b>  <b>(B134) No. 17 — (E68) No. 1:</b>  <b>(B134) No. 16 — (E68) No. 2:</b></p>	<p>Is the resistance less than 1 Ω?</p>	<p>Go to step 3.</p>	<p>Repair the harness and connector.  <b>NOTE:</b>            In this case, repair the following item:            • Open circuit in harness between ECM and oil flow control solenoid valve LH connector            • Poor contact of coupling connector</p>
<p><b>3</b>     <b>CHECK OIL FLOW CONTROL SOLENOID VALVE.</b>            Measure the resistance between oil flow control solenoid valve terminals.  <b>Terminals</b>  <b>No. 1 — No. 2:</b></p>	<p>Is the resistance 6 — 12 Ω?</p>	<p>Repair the poor contact of ECM and oil flow control solenoid valve LH connector.</p>	<p>Replace the oil flow control solenoid valve LH.            &lt;Ref. to FU(H6DO)-45, Oil Flow Control Solenoid Valve.&gt;</p>

# Diagnostic Procedure with Diagnostic Trouble Code (DTC)

ENGINE (DIAGNOSTICS)

## EW:DTC P2094 EXHAUST CAMSHAFT POSITION ACTUATOR CONTROL CIRCUIT LOW (BANK 2)

### DTC DETECTING CONDITION:

- Immediately at fault recognition
- GENERAL DESCRIPTION <Ref. to GD(H6DO)-203, DTC P2094 EXHAUST CAMSHAFT POSITION ACTUATOR CONTROL CIRCUIT LOW (BANK 2), Diagnostic Trouble Code (DTC) Detecting Criteria.>

### TROUBLE SYMPTOM:

Improper idling

### CAUTION:

After servicing or replacing faulty parts, perform Clear Memory Mode <Ref. to EN(H6DO)(diag)-62, OPERATION, Clear Memory Mode.>, and Inspection Mode <Ref. to EN(H6DO)(diag)-47, PROCEDURE, Inspection Mode.>.

### WIRING DIAGRAM:

Engine electrical system <Ref. to WI-32, Engine Electrical System.>

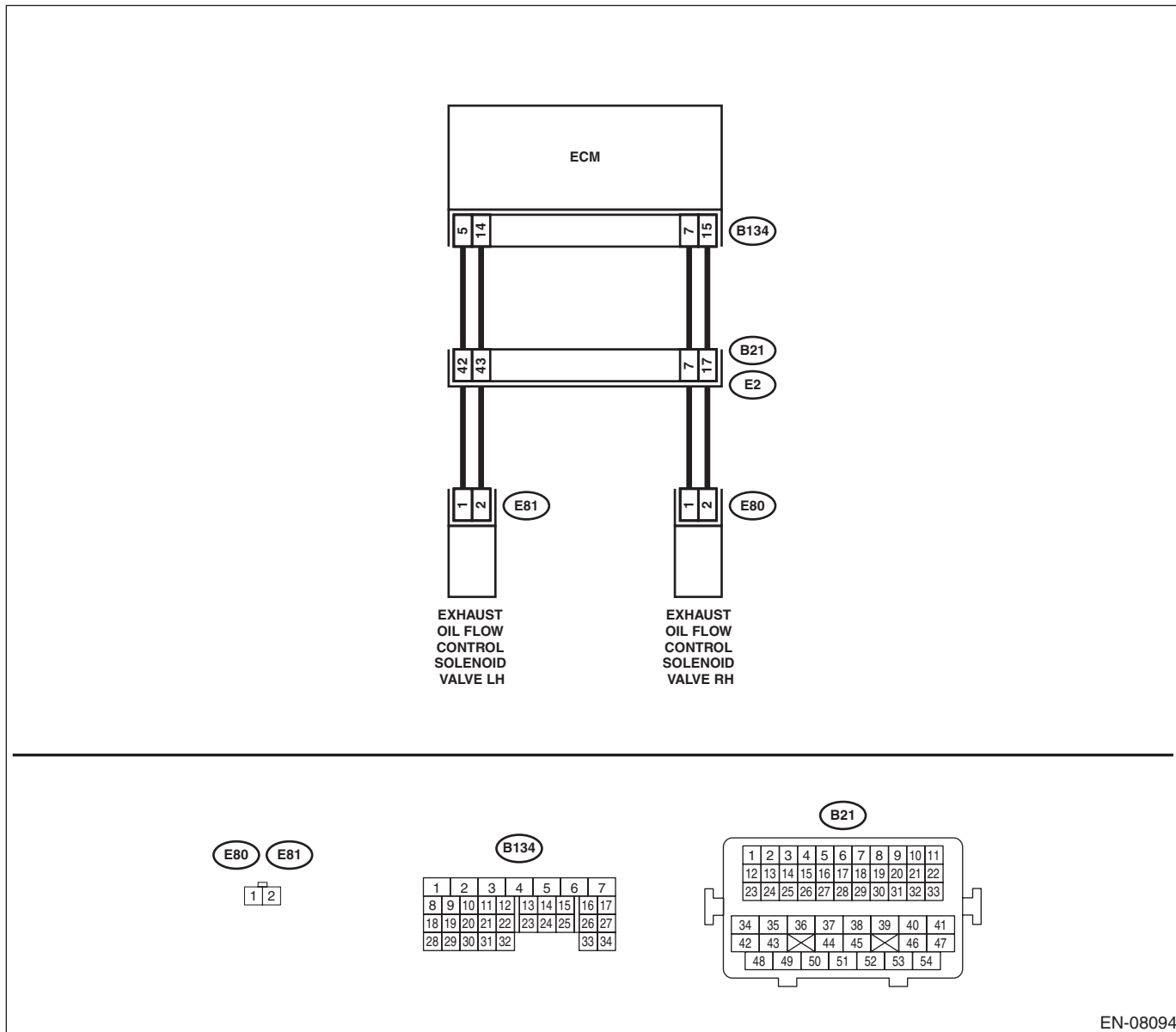

EN-08094

# Diagnostic Procedure with Diagnostic Trouble Code (DTC)

ENGINE (DIAGNOSTICS)

	Step	Check	Yes	No
1	<p><b>CHECK HARNESS BETWEEN ECM AND OIL FLOW CONTROL SOLENOID VALVE LH CONNECTOR.</b></p> <p>1) Turn the ignition switch to OFF.                      2) Disconnect the connectors from ECM and oil flow control solenoid valve LH.                      3) Measure the resistance of harness between ECM and oil flow control solenoid valve LH connector.</p> <p><b>Connector &amp; terminal</b>                      (B134) No. 5 — (E81) No. 1:                      (B134) No. 14 — (E81) No. 2:</p>	Is the resistance less than 1 Ω?	Go to step 2.	<p>Repair the harness and connector.</p> <p>NOTE:                      In this case, repair the following item:</p> <ul style="list-style-type: none"> <li>• Open circuit in harness between ECM and oil flow control solenoid valve LH connector</li> <li>• Poor contact of coupling connector</li> </ul>
2	<p><b>CHECK HARNESS BETWEEN ECM AND OIL FLOW CONTROL SOLENOID VALVE LH CONNECTOR.</b></p> <p>Measure the resistance between ECM and chassis ground.</p> <p><b>Connector &amp; terminal</b>                      (B134) No. 5 — Chassis ground:                      (B134) No. 14 — Chassis ground:</p>	Is the resistance 1 MΩ or more?	Go to step 3.	Repair the short circuit to ground in harness between ECM and oil flow control solenoid valve LH connector.
3	<p><b>CHECK OIL FLOW CONTROL SOLENOID VALVE.</b></p> <p>Measure the resistance between oil flow control solenoid valve terminals.</p> <p><b>Terminals</b>                      No. 1 — No. 2:</p>	Is the resistance 6 — 12 Ω?	Repair the poor contact of ECM and oil flow control solenoid valve LH connector.	Replace the oil flow control solenoid valve LH. <Ref. to FU(H6DO)-45, Oil Flow Control Solenoid Valve.>

# Diagnostic Procedure with Diagnostic Trouble Code (DTC)

ENGINE (DIAGNOSTICS)

## EX:DTC P2095 EXHAUST CAMSHAFT POSITION ACTUATOR CONTROL CIRCUIT HIGH (BANK 2)

### DTC DETECTING CONDITION:

- Immediately at fault recognition
- GENERAL DESCRIPTION <Ref. to GD(H6DO)-203, DTC P2095 EXHAUST CAMSHAFT POSITION ACTUATOR CONTROL CIRCUIT HIGH (BANK 2), Diagnostic Trouble Code (DTC) Detecting Criteria.>

### TROUBLE SYMPTOM:

Improper idling

### CAUTION:

After servicing or replacing faulty parts, perform Clear Memory Mode <Ref. to EN(H6DO)(diag)-62, OPERATION, Clear Memory Mode.>, and Inspection Mode <Ref. to EN(H6DO)(diag)-47, PROCEDURE, Inspection Mode.>.

### WIRING DIAGRAM:

Engine electrical system <Ref. to WI-32, Engine Electrical System.>

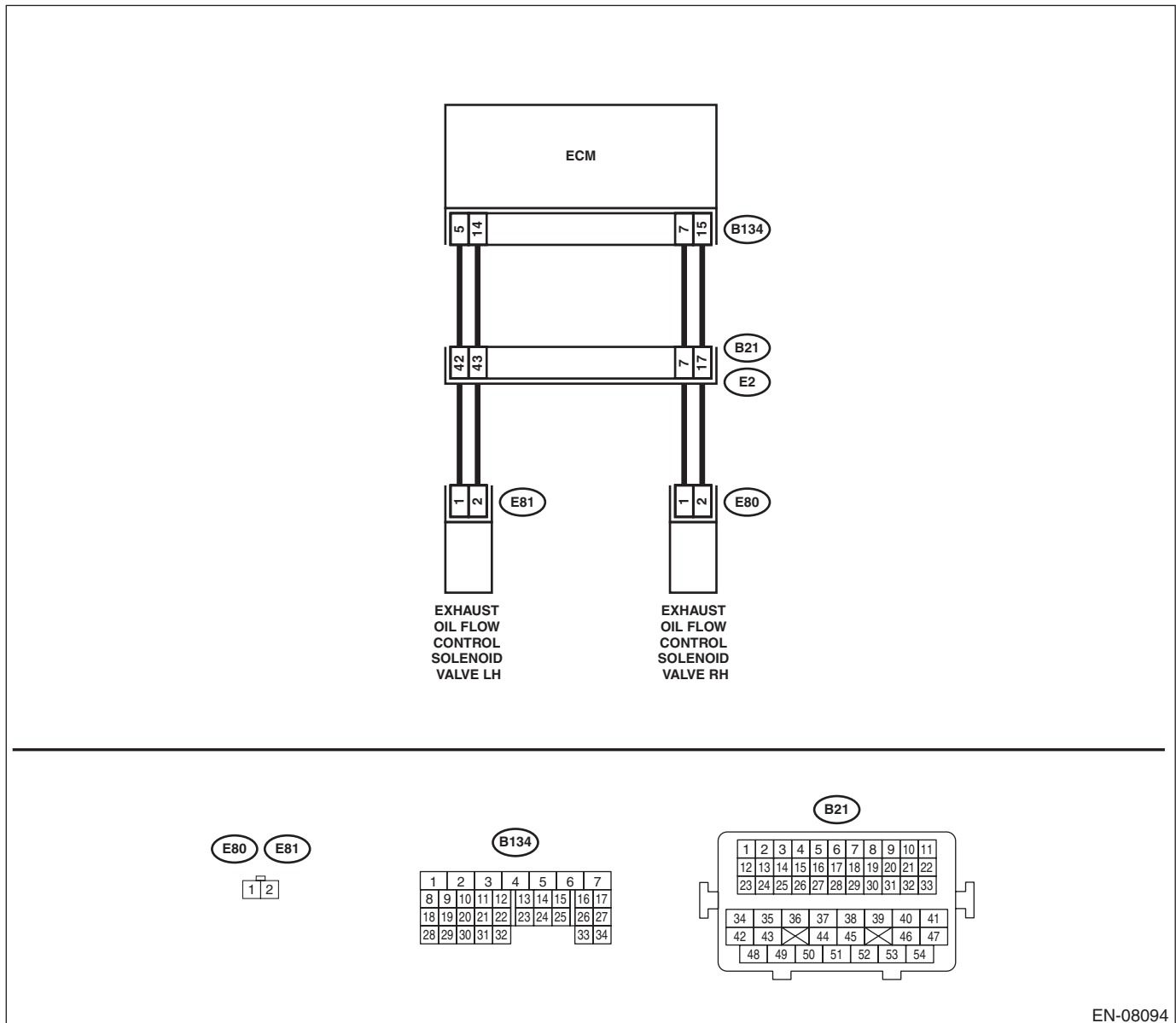

EN-08094

# Diagnostic Procedure with Diagnostic Trouble Code (DTC)

ENGINE (DIAGNOSTICS)

Step	Check	Yes	No
<p><b>1</b></p> <p><b>CHECK HARNESS BETWEEN ECM AND OIL FLOW CONTROL SOLENOID VALVE LH CONNECTOR.</b></p> <p>1) Turn the ignition switch to OFF. 2) Disconnect the connectors from ECM and oil flow control solenoid valve LH. 3) Measure the voltage between ECM and chassis ground.</p> <p><b>Connector &amp; terminal</b> <b>(B134) No. 5 (+) — Chassis ground (-):</b> <b>(B134) No. 14 (+) — Chassis ground (-):</b></p>	Is the voltage less than 1 V?	Go to step 2.	Repair the short circuit to power supply in harness between ECM and oil flow control solenoid valve LH connector.
<p><b>2</b></p> <p><b>CHECK HARNESS BETWEEN ECM AND OIL FLOW CONTROL SOLENOID VALVE LH CONNECTOR.</b></p> <p>Measure the resistance of harness between ECM and oil flow control solenoid valve LH connector.</p> <p><b>Connector &amp; terminal</b> <b>(B134) No. 5 — (E81) No. 1:</b> <b>(B134) No. 14 — (E81) No. 2:</b></p>	Is the resistance less than 1 Ω?	Go to step 3.	Repair the harness and connector. <b>NOTE:</b> In this case, repair the following item: • Open circuit in harness between ECM and oil flow control solenoid valve LH connector • Poor contact of coupling connector
<p><b>3</b></p> <p><b>CHECK OIL FLOW CONTROL SOLENOID VALVE.</b></p> <p>Measure the resistance between oil flow control solenoid valve terminals.</p> <p><b>Terminals</b> <b>No. 1 — No. 2:</b></p>	Is the resistance 6 — 12 Ω?	Repair the poor contact of ECM and oil flow control solenoid valve LH connector.	Replace the oil flow control solenoid valve LH. <Ref. to FU(H6DO)-45, Oil Flow Control Solenoid Valve.>

# Diagnostic Procedure with Diagnostic Trouble Code (DTC)

ENGINE (DIAGNOSTICS)

## EY:DTC P2096 POST CATALYST FUEL TRIM SYSTEM TOO LEAN (BANK 1)

### DTC DETECTING CONDITION:

- Detected when two consecutive driving cycles with fault occur.
- GENERAL DESCRIPTION <Ref. to GD(H6DO)-204, DTC P2096 POST CATALYST FUEL TRIM SYSTEM TOO LEAN (BANK 1), Diagnostic Trouble Code (DTC) Detecting Criteria.>

### CAUTION:

After servicing or replacing faulty parts, perform Clear Memory Mode <Ref. to EN(H6DO)(diag)-62, OPERATION, Clear Memory Mode.>, and Inspection Mode <Ref. to EN(H6DO)(diag)-47, PROCEDURE, Inspection Mode.>.

### WIRING DIAGRAM:

Engine electrical system <Ref. to WI-32, Engine Electrical System.>

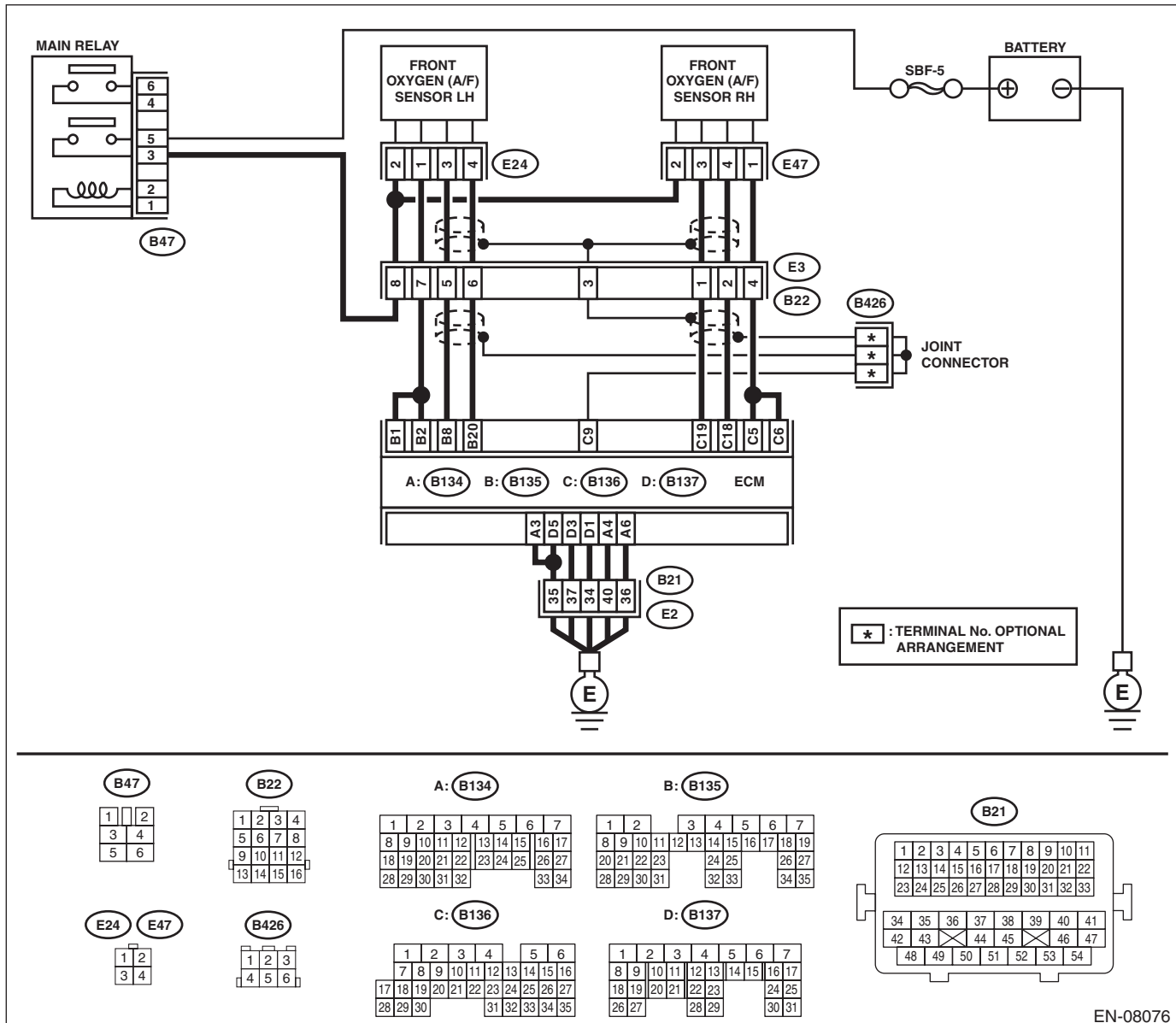

EN-08076

# Diagnostic Procedure with Diagnostic Trouble Code (DTC)

ENGINE (DIAGNOSTICS)

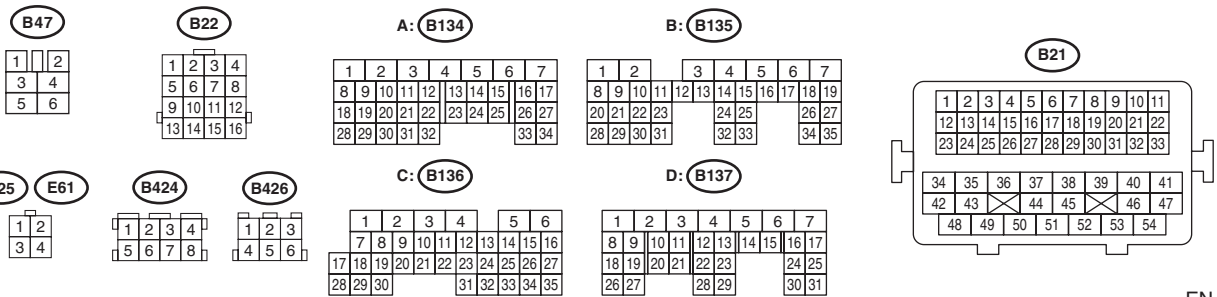
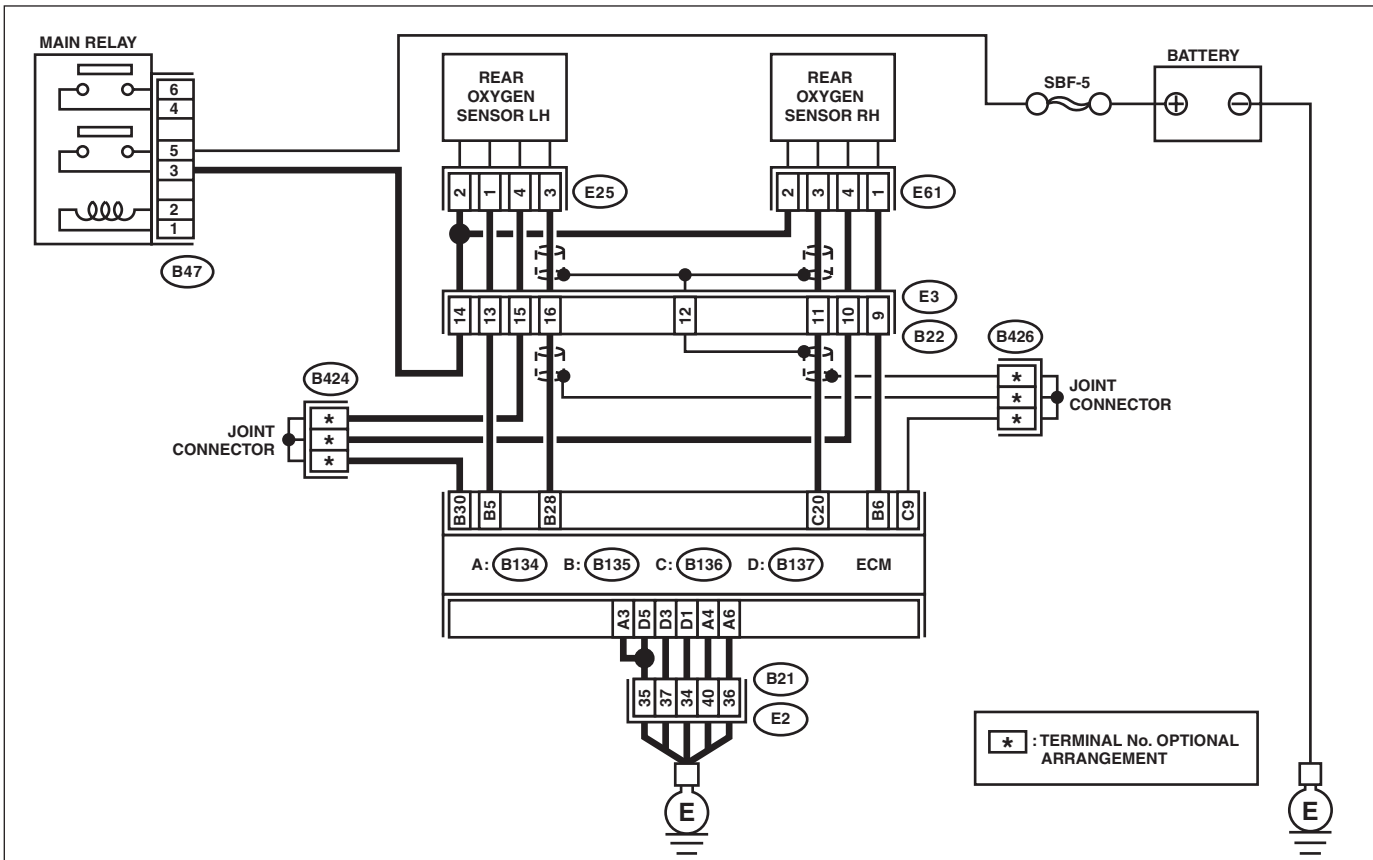

EN-08077

Step	Check	Yes	No
1	<b>CHECK FOR ANY OTHER DTC ON DISPLAY.</b> Is any other DTC displayed?	Check DTC using "List of Diagnostic Trouble Code (DTC)". <Ref. to EN(H6DO)(diag)-89, List of Diagnostic Trouble Code (DTC).>	Go to step 2.
2	<b>CHECK FRONT OXYGEN (A/F) SENSOR CONNECTOR AND COUPLING CONNECTOR.</b> Has water entered the connector?	Completely remove any water inside.	Go to step 3.

## Diagnostic Procedure with Diagnostic Trouble Code (DTC)

### ENGINE (DIAGNOSTICS)

Step	Check	Yes	No
<b>3 CHECK HARNESS BETWEEN ECM AND FRONT OXYGEN (A/F) SENSOR CONNECTOR.</b> 1) Turn the ignition switch to OFF. 2) Disconnect the connectors from ECM and front oxygen (A/F) sensor. 3) Measure the resistance of harness between ECM and front oxygen (A/F) sensor connector. <i><b>Connector &amp; terminal</b></i> <i><b>(B136) No. 19 — (E47) No. 3:</b></i> <i><b>(B136) No. 18 — (E47) No. 4:</b></i>	Is the resistance less than 1 Ω?	Go to step 4.	Repair the harness and connector.  NOTE: In this case, repair the following item: • Open circuit in harness between ECM and front oxygen (A/F) sensor connector • Poor contact of coupling connector
<b>4 CHECK HARNESS BETWEEN ECM AND FRONT OXYGEN (A/F) SENSOR CONNECTOR.</b> Measure the resistance between ECM and chassis ground. <i><b>Connector &amp; terminal</b></i> <i><b>(B136) No. 19 — Chassis ground:</b></i> <i><b>(B136) No. 18 — Chassis ground:</b></i>	Is the resistance 1 MΩ or more?	Go to step 5.	Repair the ground short circuit of harness between ECM and front oxygen (A/F) sensor connector.
<b>5 CHECK OUTPUT SIGNAL FOR ECM.</b> 1) Connect the connector to ECM. 2) Turn the ignition switch to ON. 3) Measure the voltage between front oxygen (A/F) sensor connector and chassis ground. <i><b>Connector &amp; terminal</b></i> <i><b>(E47) No. 3 (+) — Chassis ground (-):</b></i>	Is the voltage 4.5 V or more?	Go to step 7.	Go to step 6.
<b>6 CHECK OUTPUT SIGNAL FOR ECM.</b> Measure the voltage between front oxygen (A/F) sensor connector and chassis ground. <i><b>Connector &amp; terminal</b></i> <i><b>(E47) No. 4 (+) — Chassis ground (-):</b></i>	Is the voltage 4.95 V or more?	Go to step 7.	Go to step 8.
<b>7 CHECK OUTPUT SIGNAL FOR ECM.</b> Measure the voltage between front oxygen (A/F) sensor connector and chassis ground. <i><b>Connector &amp; terminal</b></i> <i><b>(E47) No. 3 (+) — Chassis ground (-):</b></i> <i><b>(E47) No. 4 (+) — Chassis ground (-):</b></i>	Is the voltage 8 V or more?	Repair the short circuit to power in the harness between ECM and front oxygen (A/F) sensor connector. After repair, replace the ECM. <Ref. to FU(H6DO)-51, Engine Control Module (ECM).>	Repair the poor contact of ECM connector.
<b>8 CHECK EXHAUST SYSTEM.</b>	Are there holes or loose bolts on exhaust system?	Repair the exhaust system.	Go to step 9.
<b>9 CHECK AIR INTAKE SYSTEM.</b>	Are there holes, loose bolts or disconnection of hose on air intake system?	Repair the air intake system.	Go to step 10.



# Diagnostic Procedure with Diagnostic Trouble Code (DTC)

ENGINE (DIAGNOSTICS)

Step	Check	Yes	No
<p><b>10 CHECK FUEL PRESSURE.</b>  <b>WARNING:</b>                      Place “NO OPEN FLAMES” signs near the working area.  <b>CAUTION:</b>                      Be careful not to spill fuel.                      1) Connect the front oxygen (A/F) sensor connector.                      2) Measure the fuel pressure. &lt;Ref. to ME(H6DO)-31, INSPECTION, Fuel Pressure.&gt;  <b>CAUTION:</b>                      Release fuel pressure before removing the fuel pressure gauge.</p>	<p>Is the measured value 340 — 400 kPa (3.5 — 4.1 kgf/cm<sup>2</sup>, 49 — 58 psi)?</p>	<p>Go to step 11.</p>	<p>Repair the following item.                      Fuel pressure is too high:                      • Clogged fuel line or bent hose                      Fuel pressure is too low:                      • Improper fuel pump discharge                      • Clogged fuel line</p>
<p><b>11 CHECK ENGINE COOLANT TEMPERATURE SENSOR.</b>                      1) Start the engine and warm up completely.                      2) Read the value of «Coolant Temp.» using the Subaru Select Monitor or a general scan tool.                      NOTE:                      • Subaru Select Monitor                      For detailed operation procedures, refer to “READ CURRENT DATA FOR ENGINE”. &lt;Ref. to EN(H6DO)(diag)-37, Subaru Select Monitor.&gt;                      • General scan tool                      For detailed operation procedures, refer to the general scan tool operation manual.</p>	<p>Is the value of «Coolant Temp.» 75°C (167°F) or more?</p>	<p>Go to step 12.</p>	<p>Replace the engine coolant temperature sensor. &lt;Ref. to FU(H6DO)-30, Engine Coolant Temperature Sensor.&gt;</p>
<p><b>12 CHECK MASS AIR FLOW AND INTAKE AIR TEMPERATURE SENSOR.</b>                      1) Start the engine and warm up engine until coolant temperature is higher than 75°C (167°F).                      2) Place the select lever in “P” range or “N” range.                      3) Turn the A/C switch to OFF.                      4) Turn all the accessory switches to OFF.                      5) Read the value of «Mass Air Flow» using the Subaru Select Monitor or a general scan tool.                      NOTE:                      • Subaru Select Monitor                      For detailed operation procedures, refer to “READ CURRENT DATA FOR ENGINE”. &lt;Ref. to EN(H6DO)(diag)-37, Subaru Select Monitor.&gt;                      • General scan tool                      For detailed operation procedures, refer to the general scan tool operation manual.</p>	<p>Is the value of «Mass Air Flow» 2.0 — 5.0 g/s (0.26 — 0.66 lb/m)?</p>	<p>Go to step 13.</p>	<p>Replace the mass air flow and intake air temperature sensor. &lt;Ref. to FU(H6DO)-40, Mass Air Flow and Intake Air Temperature Sensor.&gt;</p>

# Diagnostic Procedure with Diagnostic Trouble Code (DTC)

## ENGINE (DIAGNOSTICS)

Step	Check	Yes	No
<p><b>13 CHECK MASS AIR FLOW AND INTAKE AIR TEMPERATURE SENSOR.</b></p> <p>1) Start the engine and warm up engine until coolant temperature is higher than 75°C (167°F).</p> <p>2) Place the select lever in “P” range or “N” range.</p> <p>3) Turn the A/C switch to OFF.</p> <p>4) Turn all the accessory switches to OFF.</p> <p>5) Open the front hood.</p> <p>6) Measure the ambient temperature.</p> <p>7) Read the value of «Intake Air Temp.» using the Subaru Select Monitor or a general scan tool.</p> <p>NOTE:</p> <ul style="list-style-type: none"> <li>• Subaru Select Monitor</li> </ul> <p>For detailed operation procedures, refer to “READ CURRENT DATA FOR ENGINE”. &lt;Ref. to EN(H6DO)(diag)-37, Subaru Select Monitor.&gt;</p> <ul style="list-style-type: none"> <li>• General scan tool</li> </ul> <p>For detailed operation procedures, refer to the general scan tool operation manual.</p>	<p>Subtract ambient temperature from «Intake Air Temp.». Is the obtained value –10 — 50°C (–18 — 90°F)?</p>	Go to step 14.	Check the mass air flow and intake air temperature sensor. <Ref. to FU(H6DO)-40, Mass Air Flow and Intake Air Temperature Sensor.>
<p><b>14 CHECK REAR OXYGEN SENSOR DATA.</b></p> <p>1) Warm up the engine until engine coolant temperature is higher than 75°C (167°F), and keep the engine speed at 3,000 rpm. (2 minutes maximum)</p> <p>2) Read the value of «Front O2 Sensor #1» using the Subaru Select Monitor or a general scan tool.</p> <p>NOTE:</p> <ul style="list-style-type: none"> <li>• Subaru Select Monitor</li> </ul> <p>For detailed operation procedures, refer to “READ CURRENT DATA FOR ENGINE”. &lt;Ref. to EN(H6DO)(diag)-37, Subaru Select Monitor.&gt;</p> <ul style="list-style-type: none"> <li>• General scan tool</li> </ul> <p>For detailed operation procedures, refer to the general scan tool operation manual.</p>	<p>Is the value of «Front O2 Sensor #1» 0.490 V or more?</p>	Go to step 15.	Go to step 16.
<p><b>15 CHECK REAR OXYGEN SENSOR DATA.</b></p> <p>1) Warm up the engine until engine coolant temperature is higher than 75°C (167°F), and rapidly reduce the engine speed from 3,000 rpm.</p> <p>2) Read the value of «Front O2 Sensor #1» using the Subaru Select Monitor or a general scan tool.</p> <p>NOTE:</p> <ul style="list-style-type: none"> <li>• Subaru Select Monitor</li> </ul> <p>For detailed operation procedures, refer to “READ CURRENT DATA FOR ENGINE”. &lt;Ref. to EN(H6DO)(diag)-37, Subaru Select Monitor.&gt;</p> <ul style="list-style-type: none"> <li>• General scan tool</li> </ul> <p>For detailed operation procedures, refer to the general scan tool operation manual.</p>	<p>Is the value of «Front O2 Sensor #1» 0.250 V or less?</p>	Go to step 17.	Go to step 16.
<p><b>16 CHECK REAR OXYGEN SENSOR CONNECTOR AND COUPLING CONNECTOR.</b></p>	<p>Has water entered the connector?</p>	Completely remove any water inside.	Go to step 18.

# Diagnostic Procedure with Diagnostic Trouble Code (DTC)

ENGINE (DIAGNOSTICS)

Step	Check	Yes	No
<p><b>17 CHECK FRONT OXYGEN (A/F) SENSOR USING REAR OXYGEN SENSOR SIGNAL.</b></p> <p>1) Warm up the engine until engine coolant temperature is higher than 75°C (167°F), then keep the engine idling for 5 minutes or more.</p> <p>2) Read the value of «Front O2 Sensor #1» using the Subaru Select Monitor or a general scan tool.</p> <p>NOTE:</p> <ul style="list-style-type: none"> <li>• Subaru Select Monitor</li> </ul> <p>For detailed operation procedures, refer to “READ CURRENT DATA FOR ENGINE”. &lt;Ref. to EN(H6DO)(diag)-37, Subaru Select Monitor.&gt;</p> <ul style="list-style-type: none"> <li>• General scan tool</li> </ul> <p>For detailed operation procedures, refer to the general scan tool operation manual.</p>	<p>Is the value in «Front O2 Sensor #1» kept at 0.250 V or less for 5 minutes or more?</p>	<p>Replace the front oxygen (A/F) sensor. &lt;Ref. to FU(H6DO)-48, Front Oxygen (A/F) Sensor.&gt;</p>	<p>Go to step 18.</p>
<p><b>18 CHECK HARNESS BETWEEN ECM AND REAR OXYGEN SENSOR CONNECTOR.</b></p> <p>1) Turn the ignition switch to OFF.</p> <p>2) Disconnect the connector from ECM and rear oxygen sensor.</p> <p>3) Measure the resistance of harness between ECM and rear oxygen sensor connector.</p> <p><b>Connector &amp; terminal</b></p> <p><b>(B136) No. 20 — (E61) No. 3:</b></p> <p><b>(B135) No. 30 — (E61) No. 4:</b></p>	<p>Is the resistance less than 1 Ω?</p>	<p>Go to step 19.</p>	<p>Repair the harness and connector.</p> <p>NOTE:</p> <p>In this case, repair the following item:</p> <ul style="list-style-type: none"> <li>• Open circuit in harness between ECM and rear oxygen sensor connector</li> <li>• Poor contact of coupling connector</li> </ul>
<p><b>19 CHECK HARNESS BETWEEN ECM AND REAR OXYGEN SENSOR CONNECTOR.</b></p> <p>1) Connect the connector to ECM.</p> <p>2) Turn the ignition switch to ON.</p> <p>3) Measure the voltage between rear oxygen sensor connector and chassis ground.</p> <p><b>Connector &amp; terminal</b></p> <p><b>(E61) No. 3 (+) — Chassis ground (-):</b></p>	<p>Is the voltage 0.2 — 0.5 V?</p>	<p>Replace the rear oxygen sensor. &lt;Ref. to FU(H6DO)-50, Rear Oxygen Sensor.&gt;</p>	<p>Repair the harness and connector.</p> <p>NOTE:</p> <p>In this case, repair the following item:</p> <ul style="list-style-type: none"> <li>• Open circuit in harness between ECM and rear oxygen sensor connector</li> <li>• Poor contact of ECM connector</li> <li>• Poor contact of coupling connector</li> </ul>

# Diagnostic Procedure with Diagnostic Trouble Code (DTC)

ENGINE (DIAGNOSTICS)

## EZ:DTC P2097 POST CATALYST FUEL TRIM SYSTEM TOO RICH (BANK 1)

### DTC DETECTING CONDITION:

- Detected when two consecutive driving cycles with fault occur.
- GENERAL DESCRIPTION <Ref. to GD(H6DO)-206, DTC P2097 POST CATALYST FUEL TRIM SYSTEM TOO RICH (BANK 1), Diagnostic Trouble Code (DTC) Detecting Criteria.>

### CAUTION:

After servicing or replacing faulty parts, perform Clear Memory Mode <Ref. to EN(H6DO)(diag)-62, OPERATION, Clear Memory Mode.>, and Inspection Mode <Ref. to EN(H6DO)(diag)-47, PROCEDURE, Inspection Mode.>.

### WIRING DIAGRAM:

Engine electrical system <Ref. to WI-32, Engine Electrical System.>

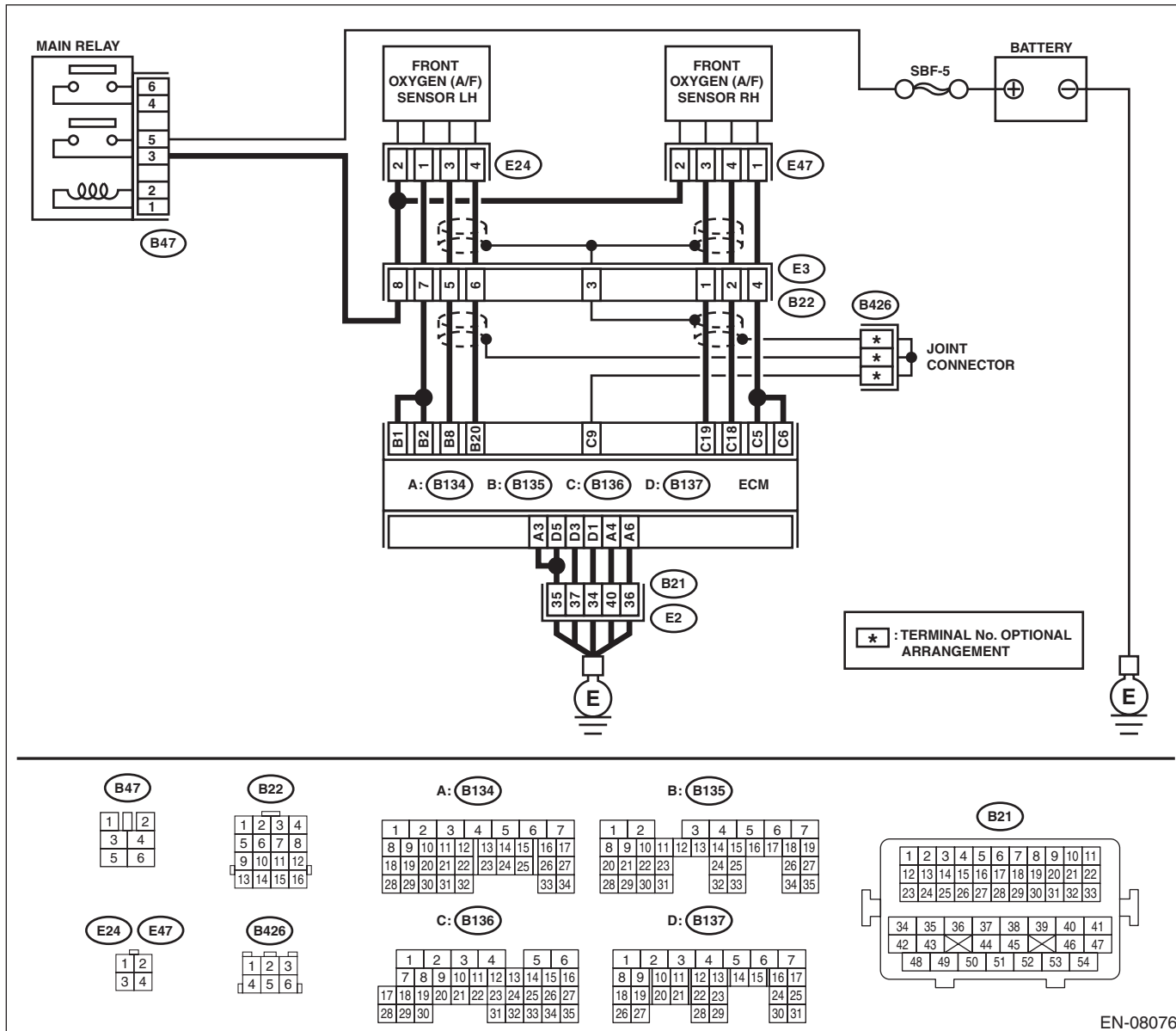

EN-08076

# Diagnostic Procedure with Diagnostic Trouble Code (DTC)

ENGINE (DIAGNOSTICS)

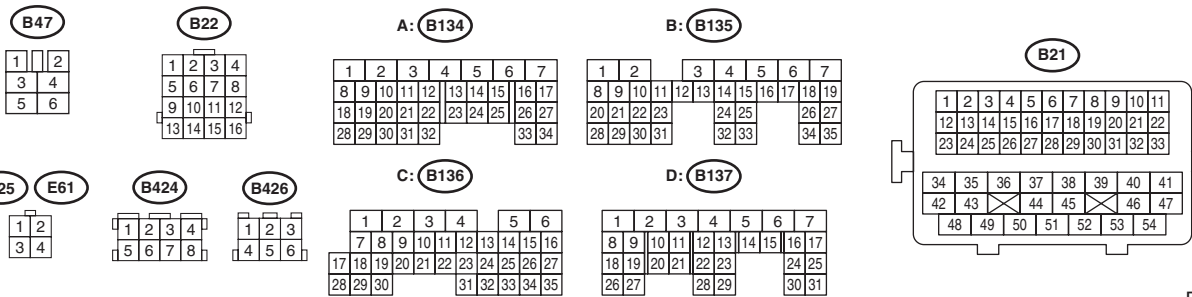
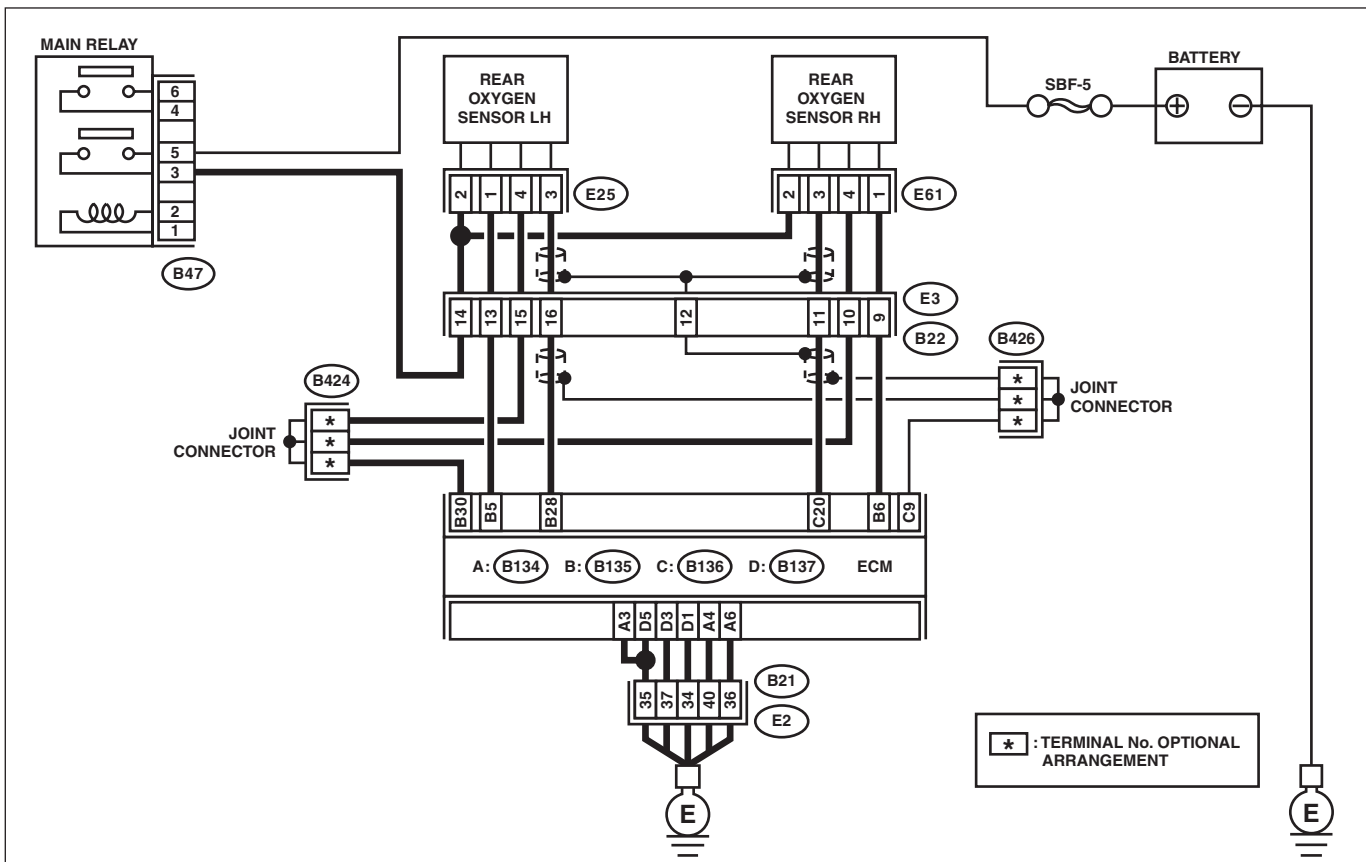

EN-08077

Step	Check	Yes	No
1	<b>CHECK FOR ANY OTHER DTC ON DISPLAY.</b> Is any other DTC displayed?	Check DTC using "List of Diagnostic Trouble Code (DTC)". <Ref. to EN(H6DO)(diag)-89, List of Diagnostic Trouble Code (DTC).>	Go to step 2.
2	<b>CHECK FRONT OXYGEN (A/F) SENSOR CONNECTOR AND COUPLING CONNECTOR.</b> Has water entered the connector?	Completely remove any water inside.	Go to step 3.

# Diagnostic Procedure with Diagnostic Trouble Code (DTC)

## ENGINE (DIAGNOSTICS)

Step	Check	Yes	No
<b>3 CHECK HARNESS BETWEEN ECM AND FRONT OXYGEN (A/F) SENSOR CONNECTOR.</b> 1) Turn the ignition switch to OFF. 2) Disconnect the connectors from ECM and front oxygen (A/F) sensor. 3) Measure the resistance of harness between ECM and front oxygen (A/F) sensor connector. <i><b>Connector &amp; terminal</b></i> <i><b>(B136) No. 19 — (E47) No. 3:</b></i> <i><b>(B136) No. 18 — (E47) No. 4:</b></i>	Is the resistance less than 1 Ω?	Go to step 4.	Repair the harness and connector.  NOTE: In this case, repair the following item: <ul style="list-style-type: none"> <li>• Open circuit in harness between ECM and front oxygen (A/F) sensor connector</li> <li>• Poor contact of coupling connector</li> </ul>
<b>4 CHECK HARNESS BETWEEN ECM AND FRONT OXYGEN (A/F) SENSOR CONNECTOR.</b> Measure the resistance between ECM and chassis ground. <i><b>Connector &amp; terminal</b></i> <i><b>(B136) No. 19 — Chassis ground:</b></i> <i><b>(B136) No. 18 — Chassis ground:</b></i>	Is the resistance 1 MΩ or more?	Go to step 5.	Repair the ground short circuit of harness between ECM and front oxygen (A/F) sensor connector.
<b>5 CHECK OUTPUT SIGNAL FOR ECM.</b> 1) Connect the connector to ECM. 2) Turn the ignition switch to ON. 3) Measure the voltage between front oxygen (A/F) sensor connector and chassis ground. <i><b>Connector &amp; terminal</b></i> <i><b>(E47) No. 3 (+) — Chassis ground (-):</b></i>	Is the voltage 4.5 V or more?	Go to step 7.	Go to step 6.
<b>6 CHECK OUTPUT SIGNAL FOR ECM.</b> Measure the voltage between front oxygen (A/F) sensor connector and chassis ground. <i><b>Connector &amp; terminal</b></i> <i><b>(E47) No. 4 (+) — Chassis ground (-):</b></i>	Is the voltage 4.95 V or more?	Go to step 7.	Go to step 8.
<b>7 CHECK OUTPUT SIGNAL FOR ECM.</b> Measure the voltage between front oxygen (A/F) sensor connector and chassis ground. <i><b>Connector &amp; terminal</b></i> <i><b>(E47) No. 3 (+) — Chassis ground (-):</b></i> <i><b>(E47) No. 4 (+) — Chassis ground (-):</b></i>	Is the voltage 8 V or more?	Repair the short circuit to power in the harness between ECM and front oxygen (A/F) sensor connector. After repair, replace the ECM. <Ref. to FU(H6DO)-51, Engine Control Module (ECM).>	Repair the poor contact of ECM connector.
<b>8 CHECK EXHAUST SYSTEM.</b>	Are there holes or loose bolts on exhaust system?	Repair the exhaust system.	Go to step 9.
<b>9 CHECK AIR INTAKE SYSTEM.</b>	Are there holes, loose bolts or disconnection of hose on air intake system?	Repair the air intake system.	Go to step 10.

# Diagnostic Procedure with Diagnostic Trouble Code (DTC)

ENGINE (DIAGNOSTICS)

Step	Check	Yes	No
<p><b>10</b></p> <p><b>CHECK FUEL PRESSURE.</b></p> <p><b>WARNING:</b> Place “NO OPEN FLAMES” signs near the working area.</p> <p><b>CAUTION:</b> Be careful not to spill fuel.</p> <p>1) Connect the front oxygen (A/F) sensor connector.</p> <p>2) Measure the fuel pressure. &lt;Ref. to ME(H6DO)-31, INSPECTION, Fuel Pressure.&gt;</p> <p><b>CAUTION:</b> Release fuel pressure before removing the fuel pressure gauge.</p>	<p>Is the measured value 340 — 400 kPa (3.5 — 4.1 kgf/cm<sup>2</sup>, 49 — 58 psi)?</p>	<p>Go to step 11.</p>	<p>Repair the following item.</p> <p>Fuel pressure is too high:</p> <ul style="list-style-type: none"> <li>• Clogged fuel line or bent hose</li> </ul> <p>Fuel pressure is too low:</p> <ul style="list-style-type: none"> <li>• Improper fuel pump discharge</li> <li>• Clogged fuel line</li> </ul>
<p><b>11</b></p> <p><b>CHECK ENGINE COOLANT TEMPERATURE SENSOR.</b></p> <p>1) Start the engine and warm up completely.</p> <p>2) Read the value of «Coolant Temp.» using the Subaru Select Monitor or a general scan tool.</p> <p>NOTE:</p> <ul style="list-style-type: none"> <li>• Subaru Select Monitor</li> </ul> <p>For detailed operation procedures, refer to “READ CURRENT DATA FOR ENGINE”. &lt;Ref. to EN(H6DO)(diag)-37, Subaru Select Monitor.&gt;</p> <ul style="list-style-type: none"> <li>• General scan tool</li> </ul> <p>For detailed operation procedures, refer to the general scan tool operation manual.</p>	<p>Is the value of «Coolant Temp.» 75°C (167°F) or more?</p>	<p>Go to step 12.</p>	<p>Replace the engine coolant temperature sensor. &lt;Ref. to FU(H6DO)-30, Engine Coolant Temperature Sensor.&gt;</p>
<p><b>12</b></p> <p><b>CHECK MASS AIR FLOW AND INTAKE AIR TEMPERATURE SENSOR.</b></p> <p>1) Start the engine and warm up engine until coolant temperature is higher than 75°C (167°F).</p> <p>2) Place the select lever in “P” range or “N” range.</p> <p>3) Turn the A/C switch to OFF.</p> <p>4) Turn all the accessory switches to OFF.</p> <p>5) Read the value of «Mass Air Flow» using the Subaru Select Monitor or a general scan tool.</p> <p>NOTE:</p> <ul style="list-style-type: none"> <li>• Subaru Select Monitor</li> </ul> <p>For detailed operation procedures, refer to “READ CURRENT DATA FOR ENGINE”. &lt;Ref. to EN(H6DO)(diag)-37, Subaru Select Monitor.&gt;</p> <ul style="list-style-type: none"> <li>• General scan tool</li> </ul> <p>For detailed operation procedures, refer to the general scan tool operation manual.</p>	<p>Is the value of «Mass Air Flow» 2.0 — 5.0 g/s (0.26 — 0.66 lb/m)?</p>	<p>Go to step 13.</p>	<p>Replace the mass air flow and intake air temperature sensor. &lt;Ref. to FU(H6DO)-40, Mass Air Flow and Intake Air Temperature Sensor.&gt;</p>

# Diagnostic Procedure with Diagnostic Trouble Code (DTC)

## ENGINE (DIAGNOSTICS)

Step	Check	Yes	No
<p><b>13 CHECK MASS AIR FLOW AND INTAKE AIR TEMPERATURE SENSOR.</b></p> <p>1) Start the engine and warm up engine until coolant temperature is higher than 75°C (167°F).</p> <p>2) Place the select lever in “P” range or “N” range.</p> <p>3) Turn the A/C switch to OFF.</p> <p>4) Turn all the accessory switches to OFF.</p> <p>5) Open the front hood.</p> <p>6) Measure the ambient temperature.</p> <p>7) Read the value of «Intake Air Temp.» using the Subaru Select Monitor or a general scan tool.</p> <p>NOTE:</p> <ul style="list-style-type: none"> <li>• Subaru Select Monitor</li> </ul> <p>For detailed operation procedures, refer to “READ CURRENT DATA FOR ENGINE”. &lt;Ref. to EN(H6DO)(diag)-37, Subaru Select Monitor.&gt;</p> <ul style="list-style-type: none"> <li>• General scan tool</li> </ul> <p>For detailed operation procedures, refer to the general scan tool operation manual.</p>	<p>Subtract ambient temperature from «Intake Air Temp.». Is the obtained value –10 — 50°C (–18 — 90°F)?</p>	Go to step 14.	Check the mass air flow and intake air temperature sensor. <Ref. to FU(H6DO)-40, Mass Air Flow and Intake Air Temperature Sensor.>
<p><b>14 CHECK REAR OXYGEN SENSOR DATA.</b></p> <p>1) Warm up the engine until engine coolant temperature is higher than 75°C (167°F), and keep the engine speed at 3,000 rpm. (2 minutes maximum)</p> <p>2) Read the value of «Front O2 Sensor #1» using the Subaru Select Monitor or a general scan tool.</p> <p>NOTE:</p> <ul style="list-style-type: none"> <li>• Subaru Select Monitor</li> </ul> <p>For detailed operation procedures, refer to “READ CURRENT DATA FOR ENGINE”. &lt;Ref. to EN(H6DO)(diag)-37, Subaru Select Monitor.&gt;</p> <ul style="list-style-type: none"> <li>• General scan tool</li> </ul> <p>For detailed operation procedures, refer to the general scan tool operation manual.</p>	<p>Is the value of «Front O2 Sensor #1» 0.490 V or more?</p>	Go to step 15.	Go to step 16.
<p><b>15 CHECK REAR OXYGEN SENSOR DATA.</b></p> <p>1) Warm up the engine until engine coolant temperature is higher than 75°C (167°F), and rapidly reduce the engine speed from 3,000 rpm.</p> <p>2) Read the value of «Front O2 Sensor #1» using the Subaru Select Monitor or a general scan tool.</p> <p>NOTE:</p> <ul style="list-style-type: none"> <li>• Subaru Select Monitor</li> </ul> <p>For detailed operation procedures, refer to “READ CURRENT DATA FOR ENGINE”. &lt;Ref. to EN(H6DO)(diag)-37, Subaru Select Monitor.&gt;</p> <ul style="list-style-type: none"> <li>• General scan tool</li> </ul> <p>For detailed operation procedures, refer to the general scan tool operation manual.</p>	<p>Is the value of «Front O2 Sensor #1» 0.250 V or less?</p>	Go to step 17.	Go to step 16.
<p><b>16 CHECK REAR OXYGEN SENSOR CONNECTOR AND COUPLING CONNECTOR.</b></p>	<p>Has water entered the connector?</p>	Completely remove any water inside.	Go to step 18.



# Diagnostic Procedure with Diagnostic Trouble Code (DTC)

ENGINE (DIAGNOSTICS)

Step	Check	Yes	No
<p><b>17</b>     <b>CHECK FRONT OXYGEN (A/F) SENSOR USING REAR OXYGEN SENSOR SIGNAL.</b>                      1) Warm up the engine until engine coolant temperature is higher than 75°C (167°F), then keep the engine idling for 5 minutes or more.                      2) Read the value of «Front O2 Sensor #1» using the Subaru Select Monitor or a general scan tool.                      NOTE:                      • Subaru Select Monitor                      For detailed operation procedures, refer to “READ CURRENT DATA FOR ENGINE”. &lt;Ref. to EN(H6DO)(diag)-37, Subaru Select Monitor.&gt;                      • General scan tool                      For detailed operation procedures, refer to the general scan tool operation manual.</p>	<p>Is the value in «Front O2 Sensor #1» kept at 0.8 V or more for 5 minutes or more?</p>	<p>Replace the front oxygen (A/F) sensor. &lt;Ref. to FU(H6DO)-48, Front Oxygen (A/F) Sensor.&gt;</p>	<p>Go to step 18.</p>
<p><b>18</b>     <b>CHECK HARNESS BETWEEN ECM AND REAR OXYGEN SENSOR CONNECTOR.</b>                      1) Turn the ignition switch to OFF.                      2) Disconnect the connector from ECM and rear oxygen sensor.                      3) Measure the resistance of harness between ECM and rear oxygen sensor connector.  <b>Connector &amp; terminal</b>  <b>(B136) No. 20 — (E61) No. 3:</b>  <b>(B135) No. 30 — (E61) No. 4:</b></p>	<p>Is the resistance less than 1 Ω?</p>	<p>Go to step 19.</p>	<p>Repair the harness and connector.                      NOTE:                      In this case, repair the following item:                      • Open circuit in harness between ECM and rear oxygen sensor connector                      • Poor contact of coupling connector</p>
<p><b>19</b>     <b>CHECK HARNESS BETWEEN ECM AND REAR OXYGEN SENSOR CONNECTOR.</b>                      1) Connect the connector to ECM.                      2) Turn the ignition switch to ON.                      3) Measure the voltage between rear oxygen sensor connector and chassis ground.  <b>Connector &amp; terminal</b>  <b>(E61) No. 3 (+) — Chassis ground (-):</b></p>	<p>Is the voltage 0.2 — 0.5 V?</p>	<p>Replace the rear oxygen sensor.                      &lt;Ref. to FU(H6DO)-50, Rear Oxygen Sensor.&gt;</p>	<p>Repair the harness and connector.                      NOTE:                      In this case, repair the following item:                      • Open circuit in harness between ECM and rear oxygen sensor connector                      • Poor contact of ECM connector                      • Poor contact of coupling connector</p>

# Diagnostic Procedure with Diagnostic Trouble Code (DTC)

ENGINE (DIAGNOSTICS)

## FA:DTC P2098 POST CATALYST FUEL TRIM SYSTEM TOO LEAN BANK 2

### DTC DETECTING CONDITION:

- Detected when two consecutive driving cycles with fault occur.
- GENERAL DESCRIPTION <Ref. to GD(H6DO)-207, DTC P2098 POST CATALYST FUEL TRIM SYSTEM TOO LEAN BANK 2, Diagnostic Trouble Code (DTC) Detecting Criteria.>

### CAUTION:

After servicing or replacing faulty parts, perform Clear Memory Mode <Ref. to EN(H6DO)(diag)-62, OPERATION, Clear Memory Mode.>, and Inspection Mode <Ref. to EN(H6DO)(diag)-47, PROCEDURE, Inspection Mode.>.

### WIRING DIAGRAM:

Engine electrical system <Ref. to WI-32, Engine Electrical System.>

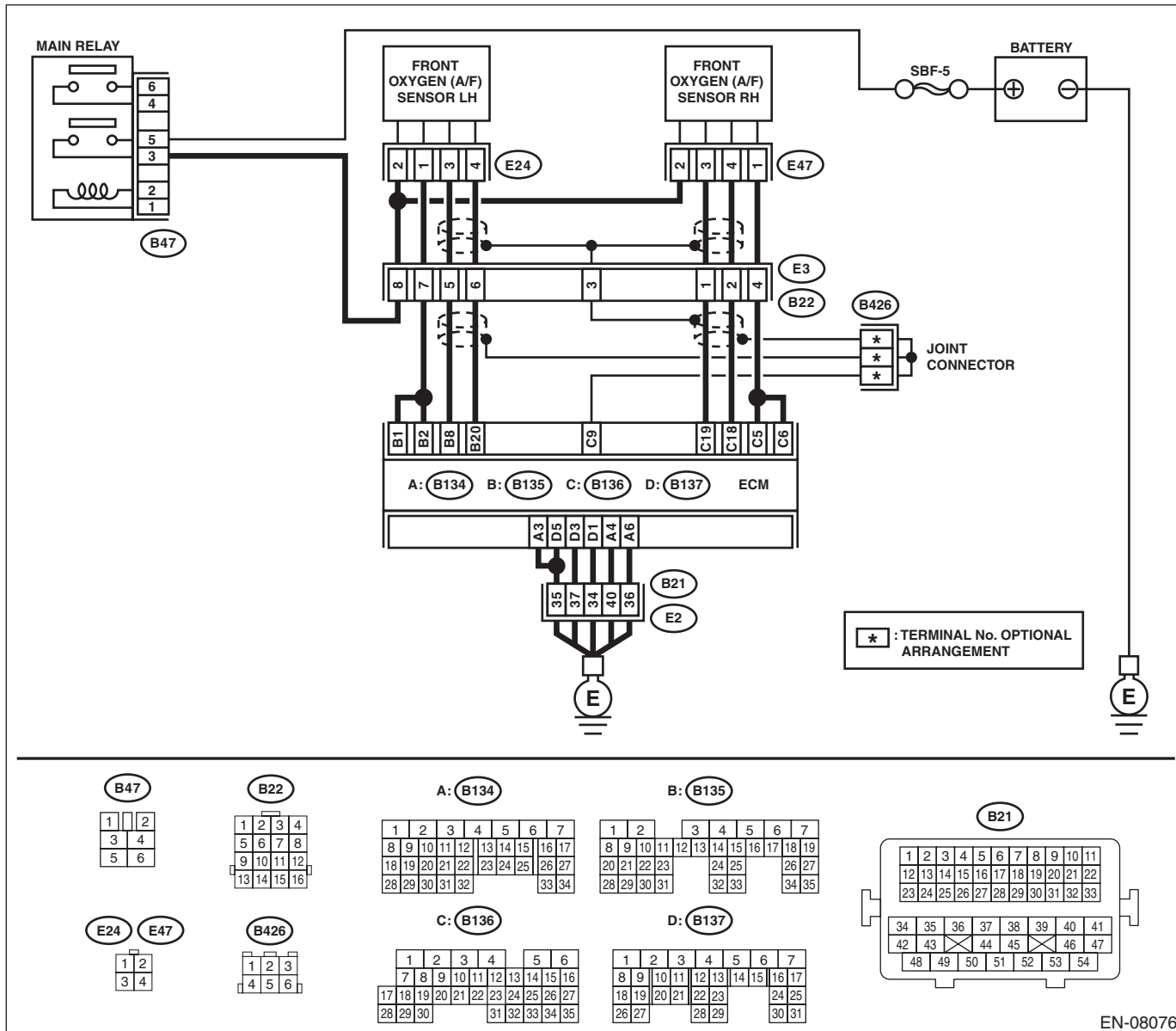

EN-08076

# Diagnostic Procedure with Diagnostic Trouble Code (DTC)

ENGINE (DIAGNOSTICS)

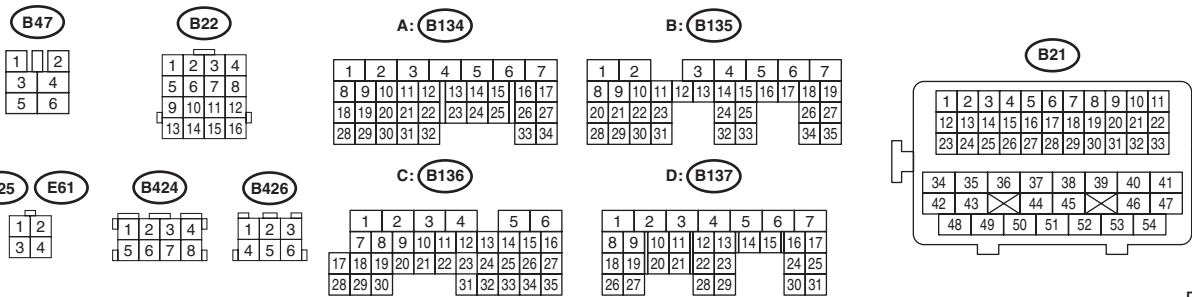
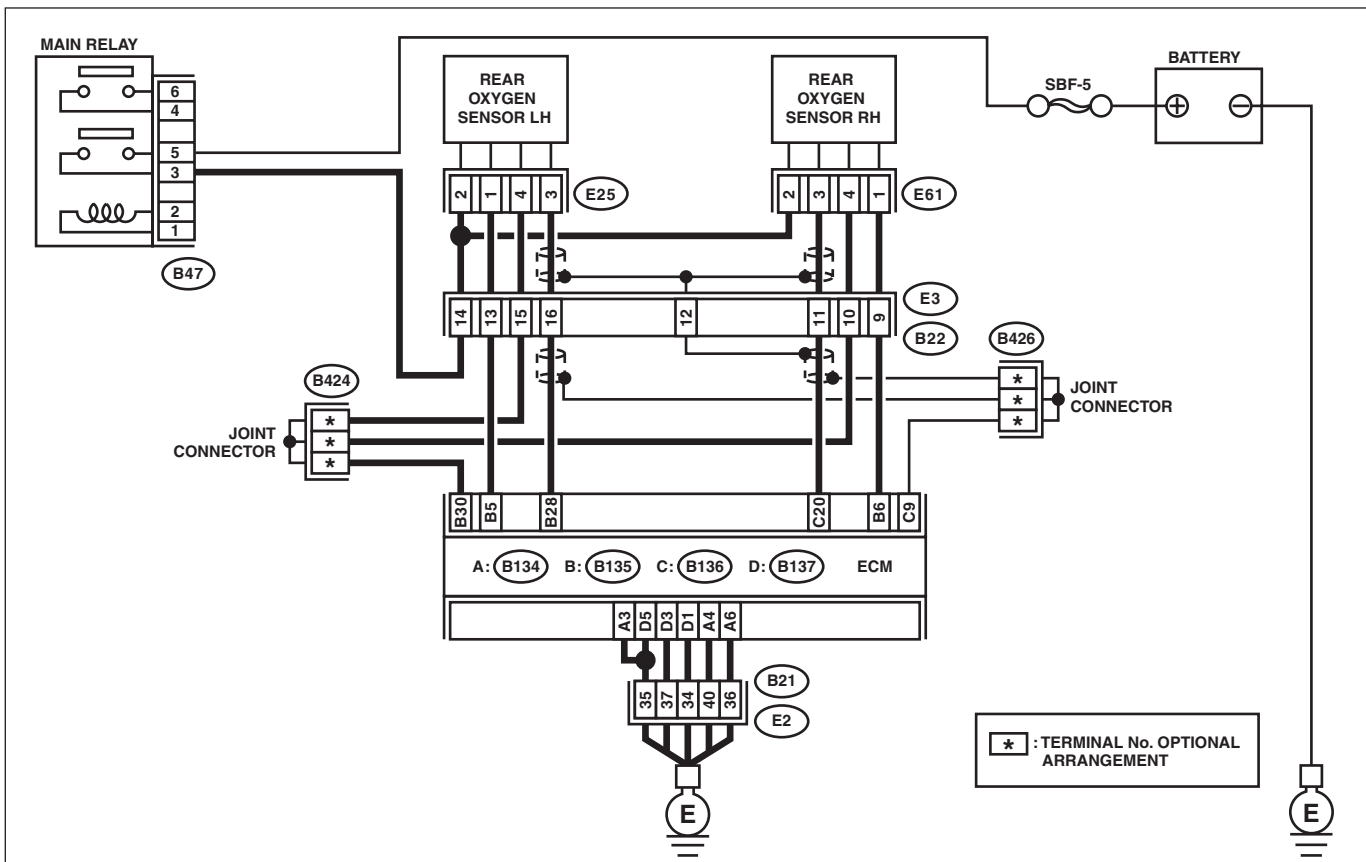

EN-08077

Step	Check	Yes	No
1	<b>CHECK FOR ANY OTHER DTC ON DISPLAY.</b> Is any other DTC displayed?	Check DTC using "List of Diagnostic Trouble Code (DTC)". <Ref. to EN(H6DO)(diag)-89, List of Diagnostic Trouble Code (DTC).>	Go to step 2.
2	<b>CHECK FRONT OXYGEN (A/F) SENSOR CONNECTOR AND COUPLING CONNECTOR.</b> Has water entered the connector?	Completely remove any water inside.	Go to step 3.

## Diagnostic Procedure with Diagnostic Trouble Code (DTC)

### ENGINE (DIAGNOSTICS)

Step	Check	Yes	No
<b>3 CHECK HARNESS BETWEEN ECM AND FRONT OXYGEN (A/F) SENSOR CONNECTOR.</b> 1) Turn the ignition switch to OFF. 2) Disconnect the connectors from ECM and front oxygen (A/F) sensor. 3) Measure the resistance of harness between ECM and front oxygen (A/F) sensor connector. <i><b>Connector &amp; terminal</b></i> <i><b>(B135) No. 8 — (E24) No. 3:</b></i> <i><b>(B135) No. 20 — (E24) No. 4:</b></i>	Is the resistance less than 1 $\Omega$ ?	Go to step 4.	Repair the harness and connector.  NOTE: In this case, repair the following item: <ul style="list-style-type: none"> <li>• Open circuit in harness between ECM and front oxygen (A/F) sensor connector</li> <li>• Poor contact of coupling connector</li> </ul>
<b>4 CHECK HARNESS BETWEEN ECM AND FRONT OXYGEN (A/F) SENSOR CONNECTOR.</b> Measure the resistance between ECM and chassis ground. <i><b>Connector &amp; terminal</b></i> <i><b>(B135) No. 8 — Chassis ground:</b></i> <i><b>(B135) No. 20 — Chassis ground:</b></i>	Is the resistance 1 M $\Omega$ or more?	Go to step 5.	Repair the ground short circuit of harness between ECM and front oxygen (A/F) sensor connector.
<b>5 CHECK OUTPUT SIGNAL FOR ECM.</b> 1) Connect the connector to ECM. 2) Turn the ignition switch to ON. 3) Measure the voltage between front oxygen (A/F) sensor connector and chassis ground. <i><b>Connector &amp; terminal</b></i> <i><b>(E24) No. 3 (+) — Chassis ground (-):</b></i>	Is the voltage 4.5 V or more?	Go to step 7.	Go to step 6.
<b>6 CHECK OUTPUT SIGNAL FOR ECM.</b> Measure the voltage between front oxygen (A/F) sensor connector and chassis ground. <i><b>Connector &amp; terminal</b></i> <i><b>(E24) No. 4 (+) — Chassis ground (-):</b></i>	Is the voltage 4.95 V or more?	Go to step 7.	Go to step 8.
<b>7 CHECK OUTPUT SIGNAL FOR ECM.</b> Measure the voltage between front oxygen (A/F) sensor connector and chassis ground. <i><b>Connector &amp; terminal</b></i> <i><b>(E24) No. 3 (+) — Chassis ground (-):</b></i> <i><b>(E24) No. 4 (+) — Chassis ground (-):</b></i>	Is the voltage 8 V or more?	Repair the short circuit to power in the harness between ECM and front oxygen (A/F) sensor connector. After repair, replace the ECM. <Ref. to FU(H6DO)-51, Engine Control Module (ECM).>	Repair the poor contact of ECM connector.
<b>8 CHECK EXHAUST SYSTEM.</b>	Are there holes or loose bolts on exhaust system?	Repair the exhaust system.	Go to step 9.
<b>9 CHECK AIR INTAKE SYSTEM.</b>	Are there holes, loose bolts or disconnection of hose on air intake system?	Repair the air intake system.	Go to step 10.

# Diagnostic Procedure with Diagnostic Trouble Code (DTC)

ENGINE (DIAGNOSTICS)

Step	Check	Yes	No
<p><b>10</b>     <b>CHECK FUEL PRESSURE.</b>  <b>WARNING:</b>  <b>Place “NO OPEN FLAMES” signs near the working area.</b>  <b>CAUTION:</b>  <b>Be careful not to spill fuel.</b>                      1) Connect the front oxygen (A/F) sensor connector.                      2) Measure the fuel pressure. &lt;Ref. to ME(H6DO)-31, INSPECTION, Fuel Pressure.&gt;  <b>CAUTION:</b>  <b>Release fuel pressure before removing the fuel pressure gauge.</b></p>	<p>Is the measured value 340 — 400 kPa (3.5 — 4.1 kgf/cm<sup>2</sup>, 49 — 58 psi)?</p>	<p>Go to step 11.</p>	<p>Repair the following item.                      Fuel pressure is too high:                      • Clogged fuel line or bent hose                      Fuel pressure is too low:                      • Improper fuel pump discharge                      • Clogged fuel line</p>
<p><b>11</b>     <b>CHECK ENGINE COOLANT TEMPERATURE SENSOR.</b>                      1) Start the engine and warm up completely.                      2) Read the value of «Coolant Temp.» using the Subaru Select Monitor or a general scan tool.  <b>NOTE:</b>                      • Subaru Select Monitor                      For detailed operation procedures, refer to “READ CURRENT DATA FOR ENGINE”. &lt;Ref. to EN(H6DO)(diag)-37, Subaru Select Monitor.&gt;                      • General scan tool                      For detailed operation procedures, refer to the general scan tool operation manual.</p>	<p>Is the value of «Coolant Temp.» 75°C (167°F) or more?</p>	<p>Go to step 12.</p>	<p>Replace the engine coolant temperature sensor. &lt;Ref. to FU(H6DO)-30, Engine Coolant Temperature Sensor.&gt;</p>
<p><b>12</b>     <b>CHECK MASS AIR FLOW AND INTAKE AIR TEMPERATURE SENSOR.</b>                      1) Start the engine and warm up engine until coolant temperature is higher than 75°C (167°F).                      2) Place the select lever in “P” range or “N” range.                      3) Turn the A/C switch to OFF.                      4) Turn all the accessory switches to OFF.                      5) Read the value of «Mass Air Flow» using the Subaru Select Monitor or a general scan tool.  <b>NOTE:</b>                      • Subaru Select Monitor                      For detailed operation procedures, refer to “READ CURRENT DATA FOR ENGINE”. &lt;Ref. to EN(H6DO)(diag)-37, Subaru Select Monitor.&gt;                      • General scan tool                      For detailed operation procedures, refer to the general scan tool operation manual.</p>	<p>Is the value of «Mass Air Flow» 2.0 — 5.0 g/s (0.26 — 0.66 lb/m)?</p>	<p>Go to step 13.</p>	<p>Replace the mass air flow and intake air temperature sensor. &lt;Ref. to FU(H6DO)-40, Mass Air Flow and Intake Air Temperature Sensor.&gt;</p>

# Diagnostic Procedure with Diagnostic Trouble Code (DTC)

## ENGINE (DIAGNOSTICS)

Step	Check	Yes	No
<p><b>13 CHECK MASS AIR FLOW AND INTAKE AIR TEMPERATURE SENSOR.</b></p> <p>1) Start the engine and warm up engine until coolant temperature is higher than 75°C (167°F).</p> <p>2) Place the select lever in “P” range or “N” range.</p> <p>3) Turn the A/C switch to OFF.</p> <p>4) Turn all the accessory switches to OFF.</p> <p>5) Open the front hood.</p> <p>6) Measure the ambient temperature.</p> <p>7) Read the value of «Intake Air Temp.» using the Subaru Select Monitor or a general scan tool.</p> <p>NOTE:</p> <ul style="list-style-type: none"> <li>• Subaru Select Monitor</li> </ul> <p>For detailed operation procedures, refer to “READ CURRENT DATA FOR ENGINE”. &lt;Ref. to EN(H6DO)(diag)-37, Subaru Select Monitor.&gt;</p> <ul style="list-style-type: none"> <li>• General scan tool</li> </ul> <p>For detailed operation procedures, refer to the general scan tool operation manual.</p>	<p>Subtract ambient temperature from «Intake Air Temp.». Is the obtained value –10 — 50°C (–18 — 90°F)?</p>	Go to step 14.	Check the mass air flow and intake air temperature sensor. <Ref. to FU(H6DO)-40, Mass Air Flow and Intake Air Temperature Sensor.>
<p><b>14 CHECK REAR OXYGEN SENSOR DATA.</b></p> <p>1) Warm up the engine until engine coolant temperature is higher than 75°C (167°F), and keep the engine speed at 3,000 rpm. (2 minutes maximum)</p> <p>2) Read the value of «Front O2 Sensor #2» using the Subaru Select Monitor or a general scan tool.</p> <p>NOTE:</p> <ul style="list-style-type: none"> <li>• Subaru Select Monitor</li> </ul> <p>For detailed operation procedures, refer to “READ CURRENT DATA FOR ENGINE”. &lt;Ref. to EN(H6DO)(diag)-37, Subaru Select Monitor.&gt;</p> <ul style="list-style-type: none"> <li>• General scan tool</li> </ul> <p>For detailed operation procedures, refer to the general scan tool operation manual.</p>	<p>Is the value of «Front O2 Sensor #2» 0.490 V or more?</p>	Go to step 15.	Go to step 16.
<p><b>15 CHECK REAR OXYGEN SENSOR DATA.</b></p> <p>1) Warm up the engine until engine coolant temperature is higher than 75°C (167°F), and rapidly reduce the engine speed from 3,000 rpm.</p> <p>2) Read the value of «Front O2 Sensor #2» using the Subaru Select Monitor or a general scan tool.</p> <p>NOTE:</p> <ul style="list-style-type: none"> <li>• Subaru Select Monitor</li> </ul> <p>For detailed operation procedures, refer to “READ CURRENT DATA FOR ENGINE”. &lt;Ref. to EN(H6DO)(diag)-37, Subaru Select Monitor.&gt;</p> <ul style="list-style-type: none"> <li>• General scan tool</li> </ul> <p>For detailed operation procedures, refer to the general scan tool operation manual.</p>	<p>Is the value of «Front O2 Sensor #2» 0.250 V or less?</p>	Go to step 17.	Go to step 16.
<p><b>16 CHECK REAR OXYGEN SENSOR CONNECTOR AND COUPLING CONNECTOR.</b></p>	<p>Has water entered the connector?</p>	Completely remove any water inside.	Go to step 18.

# Diagnostic Procedure with Diagnostic Trouble Code (DTC)

ENGINE (DIAGNOSTICS)

Step	Check	Yes	No
<p><b>17</b>     <b>CHECK FRONT OXYGEN (A/F) SENSOR USING REAR OXYGEN SENSOR SIGNAL.</b>                      1) Warm up the engine until engine coolant temperature is higher than 75°C (167°F), then keep the engine idling for 5 minutes or more.                      2) Read the value of «Front O2 Sensor #2» using the Subaru Select Monitor or a general scan tool.</p> <p>NOTE:                      • Subaru Select Monitor                      For detailed operation procedures, refer to “READ CURRENT DATA FOR ENGINE”. &lt;Ref. to EN(H6DO)(diag)-37, Subaru Select Monitor.&gt;                      • General scan tool                      For detailed operation procedures, refer to the general scan tool operation manual.</p>	<p>Is the value in «Front O2 Sensor #2» kept at 0.250 V or less for 5 minutes or more?</p>	<p>Replace the front oxygen (A/F) sensor. &lt;Ref. to FU(H6DO)-48, Front Oxygen (A/F) Sensor.&gt;</p>	<p>Go to step 18.</p>
<p><b>18</b>     <b>CHECK HARNESS BETWEEN ECM AND REAR OXYGEN SENSOR CONNECTOR.</b>                      1) Turn the ignition switch to OFF.                      2) Disconnect the connector from ECM and rear oxygen sensor.                      3) Measure the resistance of harness between ECM and rear oxygen sensor connector.</p> <p><b>Connector &amp; terminal</b>                      (B135) No. 28 — (E25) No. 3:                      (B135) No. 30 — (E25) No. 4:</p>	<p>Is the resistance less than 1 Ω?</p>	<p>Go to step 19.</p>	<p>Repair the harness and connector.</p> <p>NOTE:                      In this case, repair the following item:                      • Open circuit in harness between ECM and rear oxygen sensor connector                      • Poor contact of coupling connector</p>
<p><b>19</b>     <b>CHECK HARNESS BETWEEN ECM AND REAR OXYGEN SENSOR CONNECTOR.</b>                      1) Connect the connector to ECM.                      2) Turn the ignition switch to ON.                      3) Measure the voltage between rear oxygen sensor connector and chassis ground.</p> <p><b>Connector &amp; terminal</b>                      (E25) No. 3 (+) — Chassis ground (-):</p>	<p>Is the voltage 0.2 — 0.5 V?</p>	<p>Replace the rear oxygen sensor.                      &lt;Ref. to FU(H6DO)-50, Rear Oxygen Sensor.&gt;</p>	<p>Repair the harness and connector.</p> <p>NOTE:                      In this case, repair the following item:                      • Open circuit in harness between ECM and rear oxygen sensor connector                      • Poor contact of ECM connector                      • Poor contact of coupling connector</p>

# Diagnostic Procedure with Diagnostic Trouble Code (DTC)

ENGINE (DIAGNOSTICS)

## FB:DTC P2099 POST CATALYST FUEL TRIM SYSTEM TOO RICH BANK 2

### DTC DETECTING CONDITION:

- Detected when two consecutive driving cycles with fault occur.
- GENERAL DESCRIPTION <Ref. to GD(H6DO)-207, DTC P2099 POST CATALYST FUEL TRIM SYSTEM TOO RICH BANK 2, Diagnostic Trouble Code (DTC) Detecting Criteria.>

### CAUTION:

After servicing or replacing faulty parts, perform Clear Memory Mode <Ref. to EN(H6DO)(diag)-62, OPERATION, Clear Memory Mode.>, and Inspection Mode <Ref. to EN(H6DO)(diag)-47, PROCEDURE, Inspection Mode.>.

### WIRING DIAGRAM:

Engine electrical system <Ref. to WI-32, Engine Electrical System.>

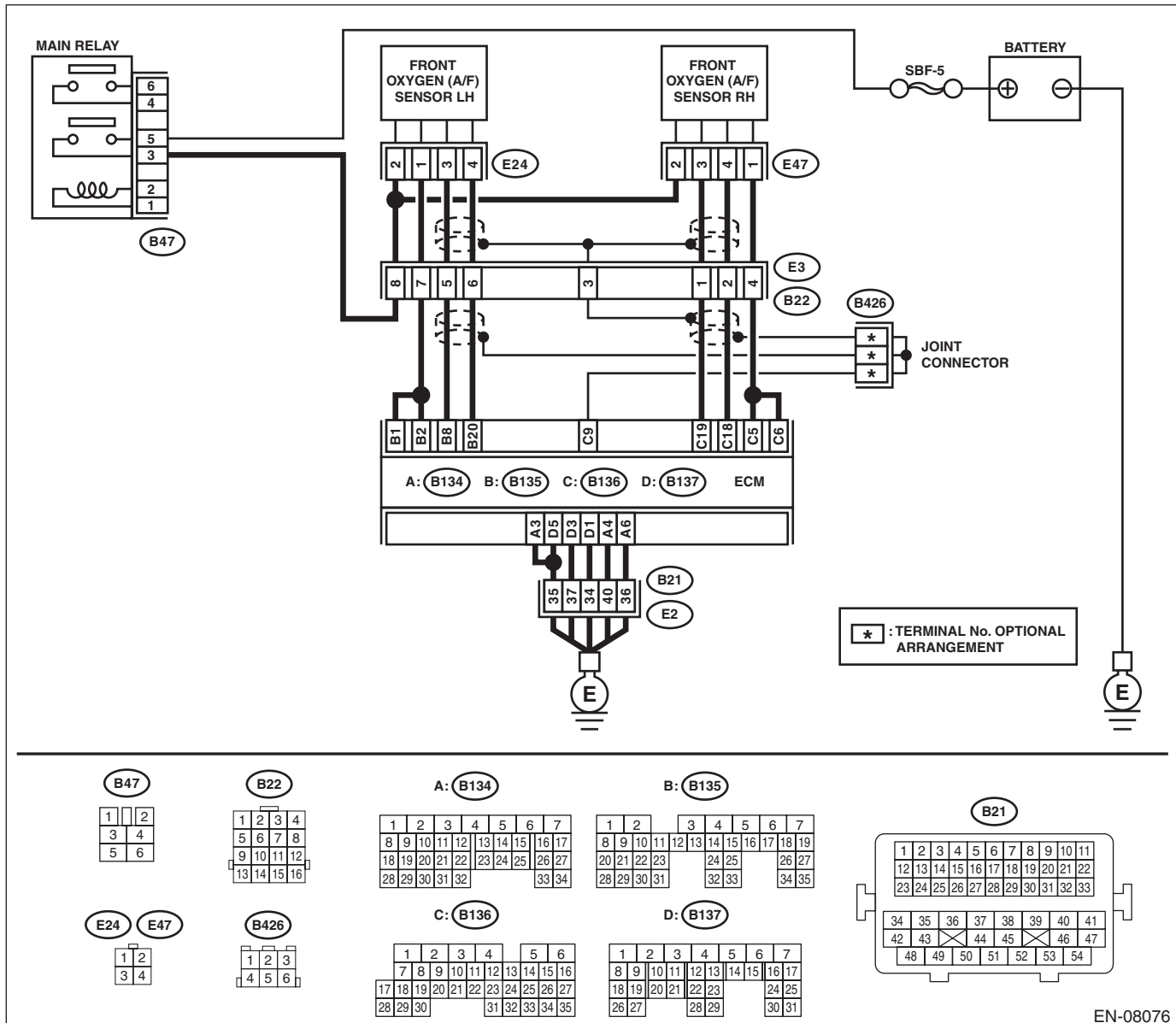

EN-08076



# Diagnostic Procedure with Diagnostic Trouble Code (DTC)

ENGINE (DIAGNOSTICS)

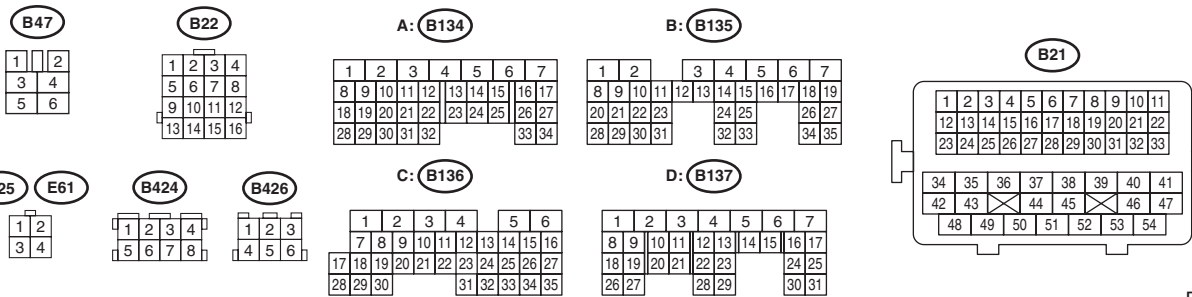
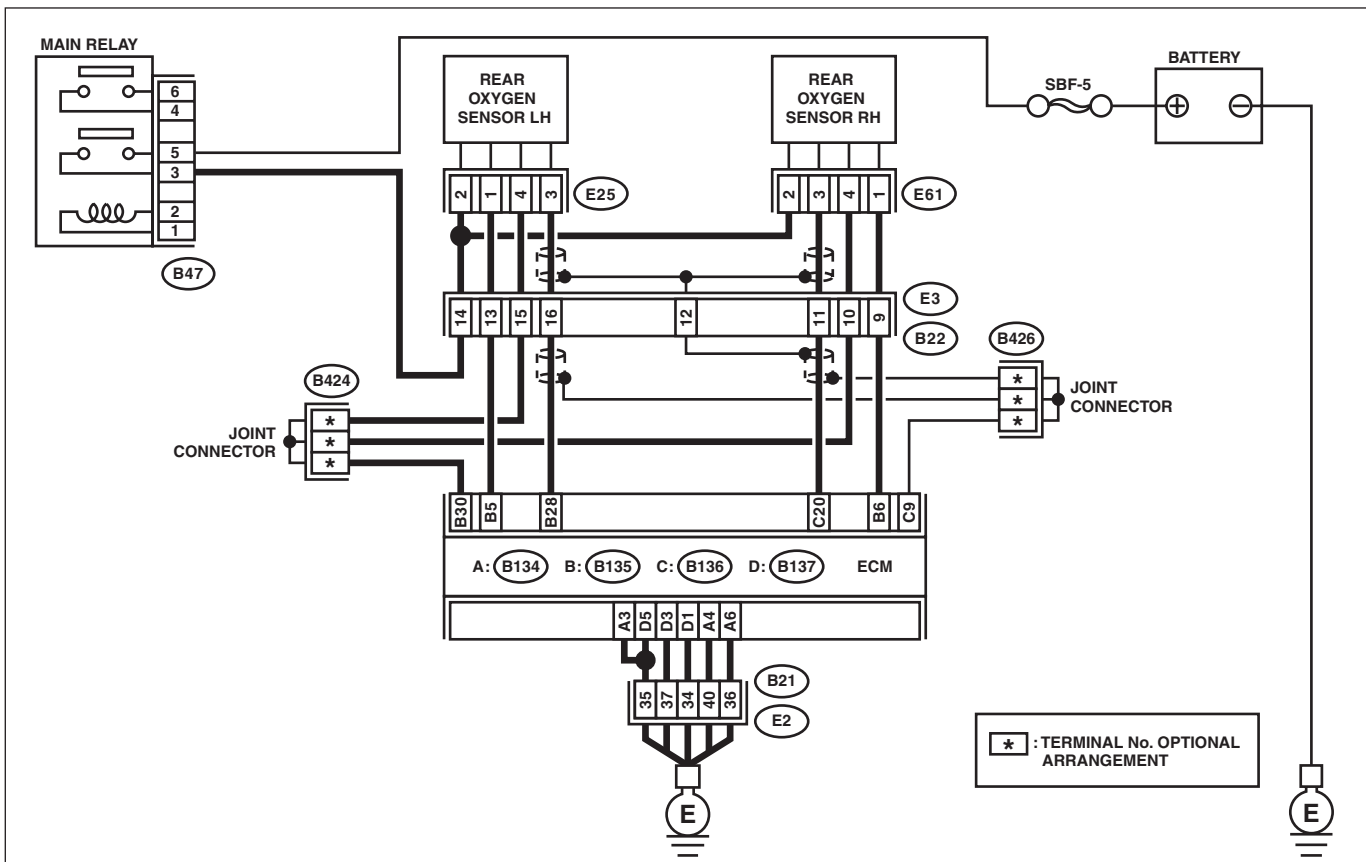

EN-08077

Step	Check	Yes	No
1	<b>CHECK FOR ANY OTHER DTC ON DISPLAY.</b> Is any other DTC displayed?	Check DTC using "List of Diagnostic Trouble Code (DTC)". <Ref. to EN(H6DO)(diag)-89, List of Diagnostic Trouble Code (DTC).>	Go to step 2.
2	<b>CHECK FRONT OXYGEN (A/F) SENSOR CONNECTOR AND COUPLING CONNECTOR.</b> Has water entered the connector?	Completely remove any water inside.	Go to step 3.

# Diagnostic Procedure with Diagnostic Trouble Code (DTC)

## ENGINE (DIAGNOSTICS)

Step	Check	Yes	No
<b>3 CHECK HARNESS BETWEEN ECM AND FRONT OXYGEN (A/F) SENSOR CONNECTOR.</b> 1) Turn the ignition switch to OFF. 2) Disconnect the connectors from ECM and front oxygen (A/F) sensor. 3) Measure the resistance of harness between ECM and front oxygen (A/F) sensor connector. <i><b>Connector &amp; terminal</b></i> <i><b>(B135) No. 8 — (E24) No. 3:</b></i> <i><b>(B135) No. 20 — (E24) No. 4:</b></i>	Is the resistance less than 1 Ω?	Go to step 4.	Repair the harness and connector.  NOTE: In this case, repair the following item: <ul style="list-style-type: none"> <li>• Open circuit in harness between ECM and front oxygen (A/F) sensor connector</li> <li>• Poor contact of coupling connector</li> </ul>
<b>4 CHECK HARNESS BETWEEN ECM AND FRONT OXYGEN (A/F) SENSOR CONNECTOR.</b> Measure the resistance between ECM and chassis ground. <i><b>Connector &amp; terminal</b></i> <i><b>(B135) No. 8 — Chassis ground:</b></i> <i><b>(B135) No. 20 — Chassis ground:</b></i>	Is the resistance 1 MΩ or more?	Go to step 5.	Repair the ground short circuit of harness between ECM and front oxygen (A/F) sensor connector.
<b>5 CHECK OUTPUT SIGNAL FOR ECM.</b> 1) Connect the connector to ECM. 2) Turn the ignition switch to ON. 3) Measure the voltage between front oxygen (A/F) sensor connector and chassis ground. <i><b>Connector &amp; terminal</b></i> <i><b>(E24) No. 3 (+) — Chassis ground (-):</b></i>	Is the voltage 4.5 V or more?	Go to step 7.	Go to step 6.
<b>6 CHECK OUTPUT SIGNAL FOR ECM.</b> Measure the voltage between front oxygen (A/F) sensor connector and chassis ground. <i><b>Connector &amp; terminal</b></i> <i><b>(E24) No. 4 (+) — Chassis ground (-):</b></i>	Is the voltage 4.95 V or more?	Go to step 7.	Go to step 8.
<b>7 CHECK OUTPUT SIGNAL FOR ECM.</b> Measure the voltage between front oxygen (A/F) sensor connector and chassis ground. <i><b>Connector &amp; terminal</b></i> <i><b>(E24) No. 3 (+) — Chassis ground (-):</b></i> <i><b>(E24) No. 4 (+) — Chassis ground (-):</b></i>	Is the voltage 8 V or more?	Repair the short circuit to power in the harness between ECM and front oxygen (A/F) sensor connector. After repair, replace the ECM. <Ref. to FU(H6DO)-51, Engine Control Module (ECM).>	Repair the poor contact of ECM connector.
<b>8 CHECK EXHAUST SYSTEM.</b>	Are there holes or loose bolts on exhaust system?	Repair the exhaust system.	Go to step 9.
<b>9 CHECK AIR INTAKE SYSTEM.</b>	Are there holes, loose bolts or disconnection of hose on air intake system?	Repair the air intake system.	Go to step 10.

# Diagnostic Procedure with Diagnostic Trouble Code (DTC)

ENGINE (DIAGNOSTICS)

Step	Check	Yes	No
<p><b>10</b>     <b>CHECK FUEL PRESSURE.</b>  <b>WARNING:</b>  <b>Place “NO OPEN FLAMES” signs near the working area.</b>  <b>CAUTION:</b>  <b>Be careful not to spill fuel.</b>                      1) Connect the front oxygen (A/F) sensor connector.                      2) Measure the fuel pressure. &lt;Ref. to ME(H6DO)-31, INSPECTION, Fuel Pressure.&gt;  <b>CAUTION:</b>  <b>Release fuel pressure before removing the fuel pressure gauge.</b></p>	<p>Is the measured value 340 — 400 kPa (3.5 — 4.1 kgf/cm<sup>2</sup>, 49 — 58 psi)?</p>	<p>Go to step 11.</p>	<p>Repair the following item.                      Fuel pressure is too high:                      • Clogged fuel line or bent hose                      Fuel pressure is too low:                      • Improper fuel pump discharge                      • Clogged fuel line</p>
<p><b>11</b>     <b>CHECK ENGINE COOLANT TEMPERATURE SENSOR.</b>                      1) Start the engine and warm up completely.                      2) Read the value of «Coolant Temp.» using the Subaru Select Monitor or a general scan tool.  <b>NOTE:</b>                      • Subaru Select Monitor                      For detailed operation procedures, refer to “READ CURRENT DATA FOR ENGINE”. &lt;Ref. to EN(H6DO)(diag)-37, Subaru Select Monitor.&gt;                      • General scan tool                      For detailed operation procedures, refer to the general scan tool operation manual.</p>	<p>Is the value of «Coolant Temp.» 75°C (167°F) or more?</p>	<p>Go to step 12.</p>	<p>Replace the engine coolant temperature sensor. &lt;Ref. to FU(H6DO)-30, Engine Coolant Temperature Sensor.&gt;</p>
<p><b>12</b>     <b>CHECK MASS AIR FLOW AND INTAKE AIR TEMPERATURE SENSOR.</b>                      1) Start the engine and warm up engine until coolant temperature is higher than 75°C (167°F).                      2) Place the select lever in “P” range or “N” range.                      3) Turn the A/C switch to OFF.                      4) Turn all the accessory switches to OFF.                      5) Read the value of «Mass Air Flow» using the Subaru Select Monitor or a general scan tool.  <b>NOTE:</b>                      • Subaru Select Monitor                      For detailed operation procedures, refer to “READ CURRENT DATA FOR ENGINE”. &lt;Ref. to EN(H6DO)(diag)-37, Subaru Select Monitor.&gt;                      • General scan tool                      For detailed operation procedures, refer to the general scan tool operation manual.</p>	<p>Is the value of «Mass Air Flow» 2.0 — 5.0 g/s (0.26 — 0.66 lb/m)?</p>	<p>Go to step 13.</p>	<p>Replace the mass air flow and intake air temperature sensor. &lt;Ref. to FU(H6DO)-40, Mass Air Flow and Intake Air Temperature Sensor.&gt;</p>

# Diagnostic Procedure with Diagnostic Trouble Code (DTC)

## ENGINE (DIAGNOSTICS)

Step	Check	Yes	No
<p><b>13 CHECK MASS AIR FLOW AND INTAKE AIR TEMPERATURE SENSOR.</b></p> <p>1) Start the engine and warm up engine until coolant temperature is higher than 75°C (167°F).</p> <p>2) Place the select lever in “P” range or “N” range.</p> <p>3) Turn the A/C switch to OFF.</p> <p>4) Turn all the accessory switches to OFF.</p> <p>5) Open the front hood.</p> <p>6) Measure the ambient temperature.</p> <p>7) Read the value of «Intake Air Temp.» using the Subaru Select Monitor or a general scan tool.</p> <p>NOTE:</p> <ul style="list-style-type: none"> <li>• Subaru Select Monitor</li> </ul> <p>For detailed operation procedures, refer to “READ CURRENT DATA FOR ENGINE”. &lt;Ref. to EN(H6DO)(diag)-37, Subaru Select Monitor.&gt;</p> <ul style="list-style-type: none"> <li>• General scan tool</li> </ul> <p>For detailed operation procedures, refer to the general scan tool operation manual.</p>	<p>Subtract ambient temperature from «Intake Air Temp.». Is the obtained value –10 — 50°C (–18 — 90°F)?</p>	Go to step 14.	Check the mass air flow and intake air temperature sensor. <Ref. to FU(H6DO)-40, Mass Air Flow and Intake Air Temperature Sensor.>
<p><b>14 CHECK REAR OXYGEN SENSOR DATA.</b></p> <p>1) Warm up the engine until engine coolant temperature is higher than 75°C (167°F), and keep the engine speed at 3,000 rpm. (2 minutes maximum)</p> <p>2) Read the value of «Front O2 Sensor #2» using the Subaru Select Monitor or a general scan tool.</p> <p>NOTE:</p> <ul style="list-style-type: none"> <li>• Subaru Select Monitor</li> </ul> <p>For detailed operation procedures, refer to “READ CURRENT DATA FOR ENGINE”. &lt;Ref. to EN(H6DO)(diag)-37, Subaru Select Monitor.&gt;</p> <ul style="list-style-type: none"> <li>• General scan tool</li> </ul> <p>For detailed operation procedures, refer to the general scan tool operation manual.</p>	<p>Is the value of «Front O2 Sensor #2» 0.490 V or more?</p>	Go to step 15.	Go to step 16.
<p><b>15 CHECK REAR OXYGEN SENSOR DATA.</b></p> <p>1) Warm up the engine until engine coolant temperature is higher than 75°C (167°F), and rapidly reduce the engine speed from 3,000 rpm.</p> <p>2) Read the value of «Front O2 Sensor #2» using the Subaru Select Monitor or a general scan tool.</p> <p>NOTE:</p> <ul style="list-style-type: none"> <li>• Subaru Select Monitor</li> </ul> <p>For detailed operation procedures, refer to “READ CURRENT DATA FOR ENGINE”. &lt;Ref. to EN(H6DO)(diag)-37, Subaru Select Monitor.&gt;</p> <ul style="list-style-type: none"> <li>• General scan tool</li> </ul> <p>For detailed operation procedures, refer to the general scan tool operation manual.</p>	<p>Is the value of «Front O2 Sensor #2» 0.250 V or less?</p>	Go to step 17.	Go to step 16.
<p><b>16 CHECK REAR OXYGEN SENSOR CONNECTOR AND COUPLING CONNECTOR.</b></p>	<p>Has water entered the connector?</p>	Completely remove any water inside.	Go to step 18.

# Diagnostic Procedure with Diagnostic Trouble Code (DTC)

ENGINE (DIAGNOSTICS)

Step	Check	Yes	No
<p><b>17</b>     <b>CHECK FRONT OXYGEN (A/F) SENSOR USING REAR OXYGEN SENSOR SIGNAL.</b>            1) Warm up the engine until engine coolant temperature is higher than 75°C (167°F), then keep the engine idling for 5 minutes or more.            2) Read the value of «Front O2 Sensor #2» using the Subaru Select Monitor or a general scan tool.            NOTE:            • Subaru Select Monitor            For detailed operation procedures, refer to “READ CURRENT DATA FOR ENGINE”. &lt;Ref. to EN(H6DO)(diag)-37, Subaru Select Monitor.&gt;            • General scan tool            For detailed operation procedures, refer to the general scan tool operation manual.</p>	<p>Is the value in «Front O2 Sensor #2» kept at 0.8 V or more for 5 minutes or more?</p>	<p>Replace the front oxygen (A/F) sensor. &lt;Ref. to FU(H6DO)-48, Front Oxygen (A/F) Sensor.&gt;</p>	<p>Go to step <b>18</b>.</p>
<p><b>18</b>     <b>CHECK HARNESS BETWEEN ECM AND REAR OXYGEN SENSOR CONNECTOR.</b>            1) Turn the ignition switch to OFF.            2) Disconnect the connector from ECM and rear oxygen sensor.            3) Measure the resistance of harness between ECM and rear oxygen sensor connector.  <b>Connector &amp; terminal</b>  <b>(B135) No. 28 — (E25) No. 3:</b>  <b>(B135) No. 30 — (E25) No. 4:</b></p>	<p>Is the resistance less than 1 Ω?</p>	<p>Go to step <b>19</b>.</p>	<p>Repair the harness and connector.            NOTE:            In this case, repair the following item:            • Open circuit in harness between ECM and rear oxygen sensor connector            • Poor contact of coupling connector</p>
<p><b>19</b>     <b>CHECK HARNESS BETWEEN ECM AND REAR OXYGEN SENSOR CONNECTOR.</b>            1) Connect the connector to ECM.            2) Turn the ignition switch to ON.            3) Measure the voltage between rear oxygen sensor connector and chassis ground.  <b>Connector &amp; terminal</b>  <b>(E25) No. 3 (+) — Chassis ground (-):</b></p>	<p>Is the voltage 0.2 — 0.5 V?</p>	<p>Replace the rear oxygen sensor.            &lt;Ref. to FU(H6DO)-50, Rear Oxygen Sensor.&gt;</p>	<p>Repair the harness and connector.            NOTE:            In this case, repair the following item:            • Open circuit in harness between ECM and rear oxygen sensor connector            • Poor contact of ECM connector            • Poor contact of coupling connector</p>

# Diagnostic Procedure with Diagnostic Trouble Code (DTC)

ENGINE (DIAGNOSTICS)

## FC:DTC P2101 THROTTLE ACTUATOR CONTROL MOTOR CIRCUIT RANGE/ PERFORMANCE

### DTC DETECTING CONDITION:

- Immediately at fault recognition
- GENERAL DESCRIPTION <Ref. to GD(H6DO)-208, DTC P2101 THROTTLE ACTUATOR CONTROL MOTOR CIRCUIT RANGE/PERFORMANCE, Diagnostic Trouble Code (DTC) Detecting Criteria.>

### TROUBLE SYMPTOM:

- Improper idling
- Poor driving performance
- Engine stalls.

### CAUTION:

After servicing or replacing faulty parts, perform Clear Memory Mode <Ref. to EN(H6DO)(diag)-62, OPERATION, Clear Memory Mode.>, and Inspection Mode <Ref. to EN(H6DO)(diag)-47, PROCEDURE, Inspection Mode.>.

### WIRING DIAGRAM:

Engine electrical system <Ref. to WI-32, Engine Electrical System.>

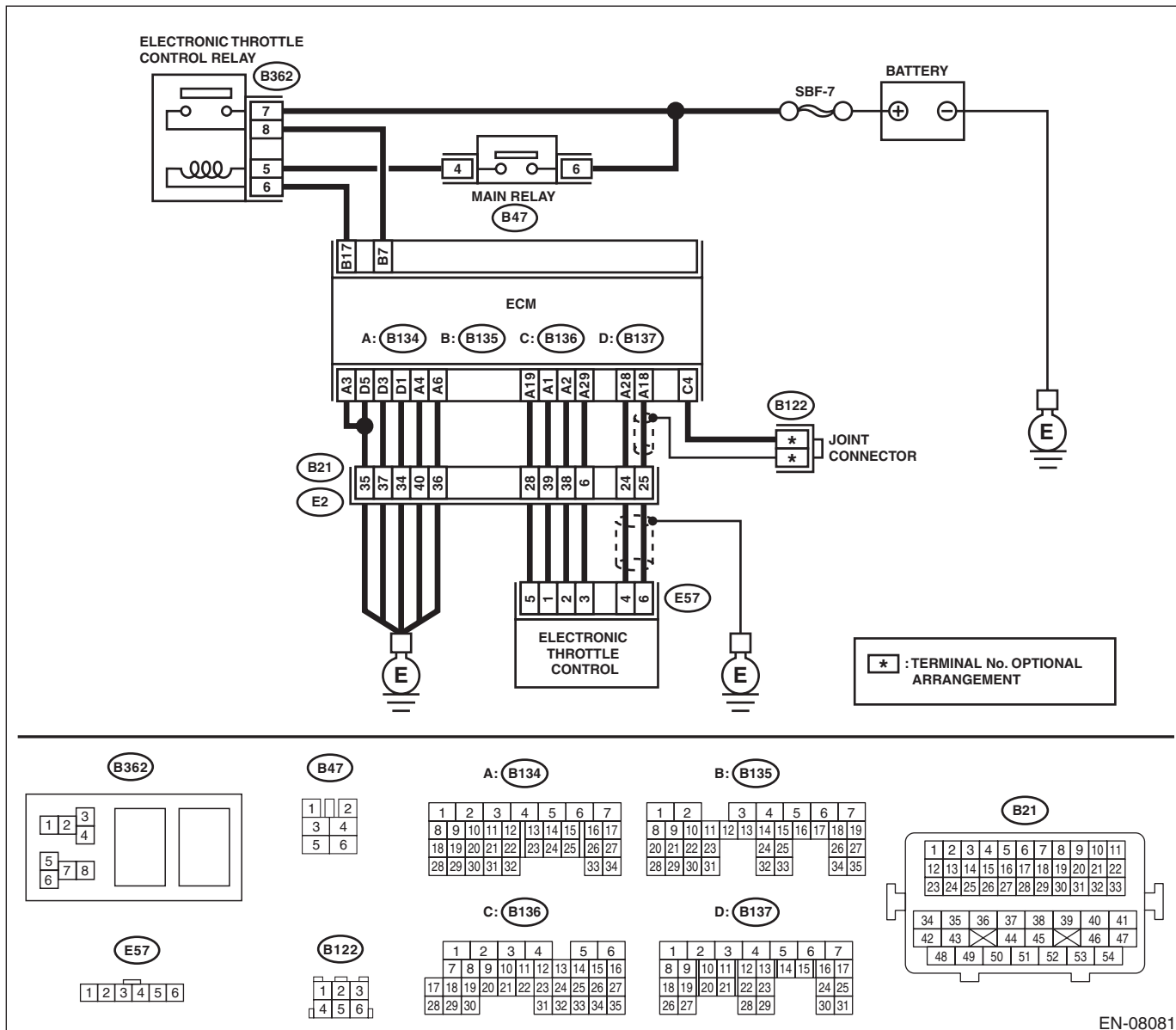

EN-08081

# Diagnostic Procedure with Diagnostic Trouble Code (DTC)

ENGINE (DIAGNOSTICS)

Step	Check	Yes	No
<b>1</b> <b>CHECK ELECTRONIC THROTTLE CONTROL RELAY.</b> 1) Turn the ignition switch to OFF. 2) Remove the electronic throttle control relay. 3) Connect the battery to terminals No. 5 and No. 6 of electronic throttle control relay. 4) Measure the resistance between electronic throttle control relay terminals. <i>Terminals</i> <i>No. 7 — No. 8:</i>	Is the resistance less than 1 $\Omega$ ?	Go to step 2.	Replace the electronic throttle control relay. <Ref. to EN(H6DO)(diag)-9, Electrical Component Location.>
<b>2</b> <b>CHECK POWER SUPPLY OF ELECTRONIC THROTTLE CONTROL RELAY.</b> Measure the voltage between electronic throttle control relay connector and chassis ground. <i>Connector &amp; terminal</i> <i>(B362) No. 7 (+) — Chassis ground (-):</i>	Is the voltage 10 V or more?	Go to step 3.	Repair the open or ground short circuit of power supply circuit.
<b>3</b> <b>CHECK HARNESS BETWEEN ECM AND ELECTRONIC THROTTLE CONTROL RELAY.</b> 1) Disconnect the connector from ECM. 2) Turn the ignition switch to ON. 3) Measure the voltage between electronic throttle control relay connector and chassis ground. <i>Connector &amp; terminal</i> <i>(B362) No. 6 (+) — Chassis ground (-):</i>	Is the voltage 10 V or more?	Repair the short circuit to power in harness between ECM and electronic throttle control relay.	Go to step 4.
<b>4</b> <b>CHECK HARNESS BETWEEN ECM AND ELECTRONIC THROTTLE CONTROL RELAY.</b> 1) Turn the ignition switch to OFF. 2) Measure the resistance between electronic throttle control relay connector and chassis ground. <i>Connector &amp; terminal</i> <i>(B362) No. 8 — Chassis ground:</i> <i>(B362) No. 6 — Chassis ground:</i>	Is the resistance 1 M $\Omega$ or more?	Go to step 5.	Repair the ground short circuit of harness between ECM and electronic throttle control relay.
<b>5</b> <b>CHECK HARNESS BETWEEN ECM AND ELECTRONIC THROTTLE CONTROL RELAY.</b> Measure the resistance between ECM and electronic throttle control relay connector. <i>Connector &amp; terminal</i> <i>(B135) No. 7 — (B362) No. 8:</i> <i>(B135) No. 17 — (B362) No. 6:</i>	Is the resistance less than 1 $\Omega$ ?	Go to step 6.	Repair the open circuit of harness between ECM and electronic throttle control relay.
<b>6</b> <b>CHECK HARNESS BETWEEN ECM AND ELECTRONIC THROTTLE CONTROL.</b> 1) Turn the ignition switch to OFF. 2) Disconnect the connectors from electronic throttle control. 3) Measure the resistance between ECM and chassis ground. <i>Connector &amp; terminal</i> <i>(B134) No. 19 — Chassis ground:</i> <i>(B134) No. 18 — Chassis ground:</i> <i>(B134) No. 18 — (B136) No. 4:</i> <i>(B134) No. 28 — Chassis ground:</i>	Is the resistance 1 M $\Omega$ or more?	Go to step 7.	Repair the short circuit to ground in harness between ECM and electronic throttle control connector.

# Diagnostic Procedure with Diagnostic Trouble Code (DTC)

## ENGINE (DIAGNOSTICS)

Step	Check	Yes	No
<b>7 CHECK SHORT CIRCUIT INSIDE THE ECM.</b> 1) Connect the connector to ECM. 2) Measure the resistance between electronic throttle control connector and engine ground. <b>Connector &amp; terminal</b> <i>(E57) No. 6 — Engine ground:</i> <i>(E57) No. 4 — Engine ground:</i>	Is the resistance 1 M $\Omega$ or more?	Go to step 8.	Repair the short circuit to ground in harness between ECM and electronic throttle control connector. Replace the ECM if defective. <Ref. to FU(H6DO)-51, Engine Control Module (ECM).>
<b>8 CHECK HARNESS BETWEEN ECM AND ELECTRONIC THROTTLE CONTROL.</b> 1) Disconnect the connector from ECM. 2) Measure the resistance of harness between ECM and electronic throttle control connector. <b>Connector &amp; terminal</b> <i>(B134) No. 18 — (E57) No. 6:</i> <i>(B134) No. 28 — (E57) No. 4:</i> <i>(B134) No. 29 — (E57) No. 3:</i>	Is the resistance less than 1 $\Omega$ ?	Go to step 9.	Repair the harness and connector.  NOTE: In this case, repair the following item: <ul style="list-style-type: none"> <li>• Open circuit in harness between ECM and electronic throttle control connector</li> <li>• Poor contact of coupling connector</li> </ul>
<b>9 CHECK HARNESS BETWEEN ECM AND ELECTRONIC THROTTLE CONTROL.</b> 1) Connect the connector to ECM. 2) Measure the resistance between electronic throttle control connector and engine ground. <b>Connector &amp; terminal</b> <i>(E57) No. 3 — Engine ground:</i>	Is the resistance less than 5 $\Omega$ ?	Go to step 10.	Repair the harness and connector.  NOTE: In this case, repair the following item: <ul style="list-style-type: none"> <li>• Open circuit of harness between ECM and engine ground</li> <li>• Poor contact of ECM connector</li> <li>• Poor contact of coupling connector</li> </ul>
<b>10 CHECK HARNESS BETWEEN ECM AND ELECTRONIC THROTTLE CONTROL.</b> 1) Turn the ignition switch to ON. 2) Measure the voltage between electronic throttle control connector and engine ground. <b>Connector &amp; terminal</b> <i>(E57) No. 6 (+) — Engine ground (-):</i> <i>(E57) No. 4 (+) — Engine ground (-):</i>	Is the voltage 5 V or more?	Repair the short circuit to power in harness between ECM and electronic throttle control connector.	Go to step 11.
<b>11 CHECK HARNESS BETWEEN ECM AND ELECTRONIC THROTTLE CONTROL.</b> 1) Turn the ignition switch to OFF. 2) Disconnect the connector from ECM. 3) Measure the resistance between ECM connectors. <b>Connector &amp; terminal</b> <i>(B134) No. 19 — (B134) No. 18:</i> <i>(B134) No. 19 — (B134) No. 28:</i>	Is the resistance 1 M $\Omega$ or more?	Go to step 12.	Repair the short circuit to power in harness between ECM and electronic throttle control connector.



# Diagnostic Procedure with Diagnostic Trouble Code (DTC)

ENGINE (DIAGNOSTICS)

Step	Check	Yes	No
<p><b>12 CHECK SENSOR OUTPUT.</b>                      1) Connect all connectors.                      2) Turn the ignition switch to ON.                      3) Read the value of «Main-Throttle Sensor» using Subaru Select Monitor.                      NOTE:                      For detailed operation procedures, refer to “READ CURRENT DATA FOR ENGINE”. &lt;Ref. to EN(H6DO)(diag)-37, Subaru Select Monitor.&gt;</p>	Is the value of «Main-Throttle Sensor» 0.81 — 0.87 V?	Go to step 13.	Repair the poor contact of electronic throttle control connector. Replace the electronic throttle control if defective. <Ref. to FU(H6DO)-19, Throttle Body.>
<p><b>13 CHECK SENSOR OUTPUT.</b>                      Read the value of «Sub-Throttle Sensor» using Subaru Select Monitor.                      NOTE:                      For detailed operation procedures, refer to “READ CURRENT DATA FOR ENGINE”. &lt;Ref. to EN(H6DO)(diag)-37, Subaru Select Monitor.&gt;</p>	Is the value of «Sub-Throttle Sensor» 1.64 — 1.70 V?	Go to step 14.	Repair the poor contact of electronic throttle control connector. Replace the electronic throttle control if defective. <Ref. to FU(H6DO)-19, Throttle Body.>
<p><b>14 CHECK HARNESS BETWEEN ECM AND ELECTRONIC THROTTLE CONTROL MOTOR.</b>                      1) Turn the ignition switch to OFF.                      2) Disconnect the connectors from ECM and electronic throttle control.                      3) Measure the resistance between ECM and electronic throttle control connector.  <i>Connector &amp; terminal</i>  <i>(B134) No. 1 — (E57) No. 1:</i>  <i>(B134) No. 2 — (E57) No. 2:</i></p>	Is the resistance less than 1 Ω?	Go to step 15.	Repair the harness and connector. NOTE: In this case, repair the following item: <ul style="list-style-type: none"> <li>• Open circuit in harness between ECM and electronic throttle control</li> <li>• Poor contact of coupling connector</li> </ul>
<p><b>15 CHECK HARNESS BETWEEN ECM AND ELECTRONIC THROTTLE CONTROL MOTOR.</b>                      1) Connect the connector to ECM.                      2) Turn the ignition switch to ON.                      3) Measure the voltage between electronic throttle control connector and engine ground.  <i>Connector &amp; terminal</i>  <i>(E57) No. 2 (+) — Engine ground (-):</i>  <i>(E57) No. 1 (+) — Engine ground (-):</i></p>	Is the voltage 5 V or more?	Repair the short circuit to power in the harness between ECM and electronic throttle control.	Go to step 16.
<p><b>16 CHECK HARNESS BETWEEN ECM AND ELECTRONIC THROTTLE CONTROL MOTOR.</b>                      1) Turn the ignition switch to OFF.                      2) Disconnect the connector from ECM.                      3) Measure the resistance between electronic throttle control connector and engine ground.  <i>Connector &amp; terminal</i>  <i>(E57) No. 2 — Engine ground:</i>  <i>(E57) No. 1 — Engine ground:</i></p>	Is the resistance 1 MΩ or more?	Go to step 17.	Repair the short circuit to ground in harness between ECM and electronic throttle control.
<p><b>17 CHECK ELECTRONIC THROTTLE CONTROL MOTOR HARNESS.</b>                      Measure the resistance between electronic throttle control connectors.  <i>Connector &amp; terminal</i>  <i>(E57) No. 2 — (E57) No. 1:</i></p>	Is the resistance 1 MΩ or more?	Go to step 18.	Repair the short circuit of harness between ECM and electronic throttle control.

## Diagnostic Procedure with Diagnostic Trouble Code (DTC)

ENGINE (DIAGNOSTICS)

Step	Check	Yes	No
<p><b>18</b>     <b>CHECK ELECTRONIC THROTTLE CONTROL GROUND CIRCUIT.</b>                      Measure the resistance between ECM and chassis ground.  <i>Connector &amp; terminal</i>  <i>(B134) No. 3 — Chassis ground:</i>  <i>(B134) No. 4 — Chassis ground:</i>  <i>(B134) No. 6 — Chassis ground:</i>  <i>(B137) No. 1 — Chassis ground:</i>  <i>(B137) No. 3 — Chassis ground:</i>  <i>(B137) No. 5 — Chassis ground:</i></p>	<p>Is the resistance less than 5 Ω?</p>	<p>Go to step <b>19</b>.</p>	<p>Repair the harness and connector.                      NOTE:                      In this case, repair the following item:</p> <ul style="list-style-type: none"> <li>• Open circuit of harness between ECM and engine ground</li> <li>• Poor contact of coupling connector</li> </ul>
<p><b>19</b>     <b>CHECK ELECTRONIC THROTTLE CONTROL.</b>                      Measure the resistance between electronic throttle control terminals.  <i>Terminals</i>  <i>No. 2 — No. 1:</i></p>	<p>Is the resistance 50 Ω or less?</p>	<p>Go to step <b>20</b>.</p>	<p>Replace the electronic throttle control. &lt;Ref. to FU(H6DO)-19, Throttle Body.&gt;</p>
<p><b>20</b>     <b>CHECK ELECTRONIC THROTTLE CONTROL.</b>                      Move the throttle valve to the fully open and fully closed positions with fingers.                      Check that the valve returns to the specified position when releasing fingers.</p>	<p>Does the valve return to the specified position? Standard value: 3 mm (0.12 in) from fully closed position</p>	<p>Repair the poor contact of ECM connector.</p>	<p>Replace the electronic throttle control. &lt;Ref. to FU(H6DO)-19, Throttle Body.&gt;</p>

# Diagnostic Procedure with Diagnostic Trouble Code (DTC)

ENGINE (DIAGNOSTICS)

## FD:DTC P2102 THROTTLE ACTUATOR CONTROL MOTOR CIRCUIT LOW

### DTC DETECTING CONDITION:

- Immediately at fault recognition
- GENERAL DESCRIPTION <Ref. to GD(H6DO)-210, DTC P2102 THROTTLE ACTUATOR CONTROL MOTOR CIRCUIT LOW, Diagnostic Trouble Code (DTC) Detecting Criteria.>

### TROUBLE SYMPTOM:

- Improper idling
- Poor driving performance
- Engine stalls.

### CAUTION:

After servicing or replacing faulty parts, perform Clear Memory Mode <Ref. to EN(H6DO)(diag)-62, OPERATION, Clear Memory Mode.>, and Inspection Mode <Ref. to EN(H6DO)(diag)-47, PROCEDURE, Inspection Mode.>.

### WIRING DIAGRAM:

Engine electrical system <Ref. to WI-32, Engine Electrical System.>

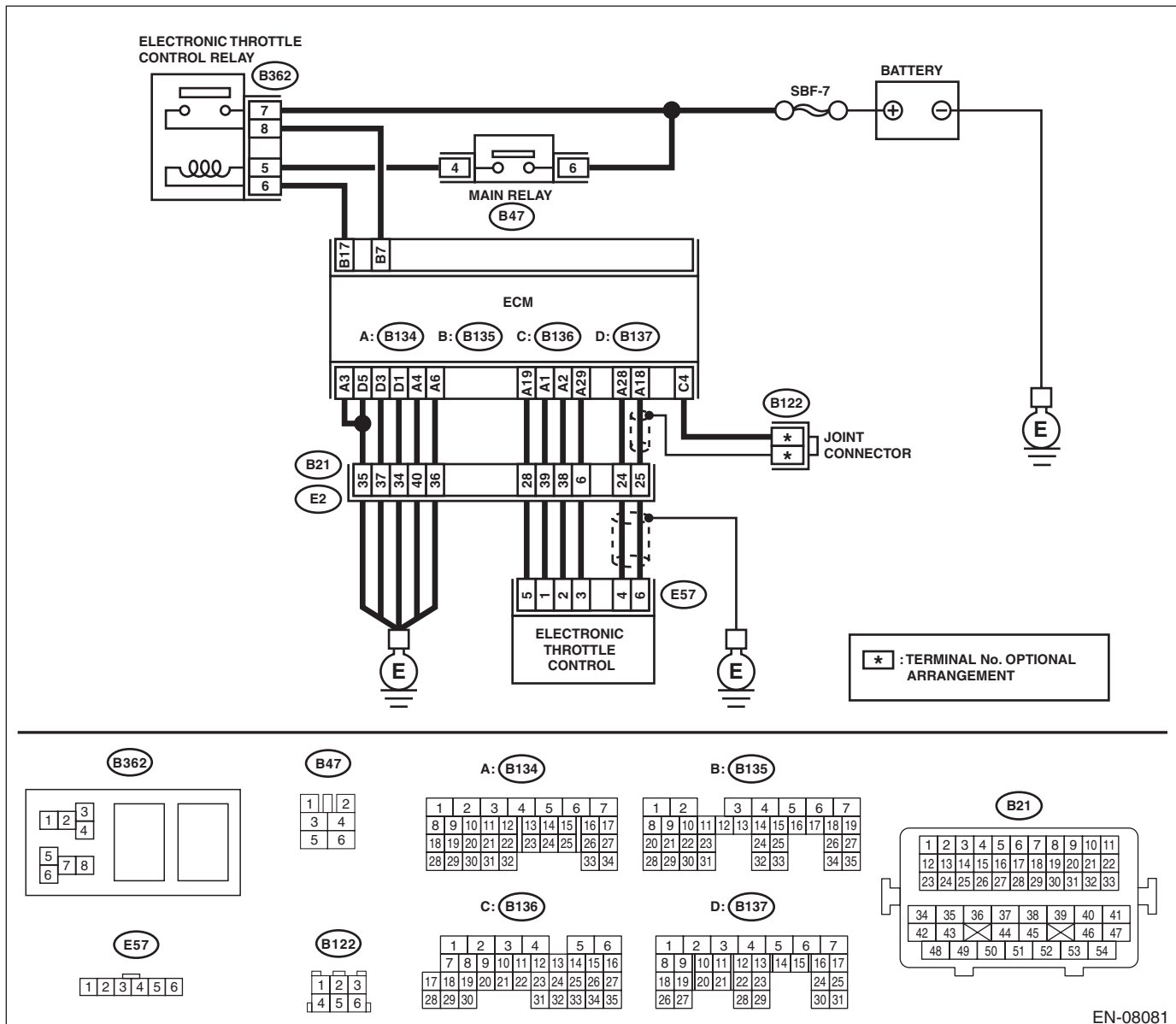

EN-08081

# Diagnostic Procedure with Diagnostic Trouble Code (DTC)

## ENGINE (DIAGNOSTICS)

Step	Check	Yes	No
<b>1 CHECK ELECTRONIC THROTTLE CONTROL RELAY.</b> 1) Turn the ignition switch to OFF. 2) Remove the electronic throttle control relay. 3) Connect the battery to terminals No. 5 and No. 6 of electronic throttle control relay. 4) Measure the resistance between electronic throttle control relay terminals. <b>Terminals</b> <b>No. 7 — No. 8:</b>	Is the resistance less than 1 $\Omega$ ?	Go to step 2.	Replace the electronic throttle control relay. <Ref. to EN(H6DO)(diag)-9, Electrical Component Location.>
<b>2 CHECK POWER SUPPLY OF ELECTRONIC THROTTLE CONTROL RELAY.</b> Measure the voltage between electronic throttle control relay connector and chassis ground. <b>Connector &amp; terminal</b> <b>(B362) No. 7 (+) — Chassis ground (-):</b>	Is the voltage 10 V or more?	Go to step 3.	Repair the open or ground short circuit of power supply circuit.
<b>3 CHECK HARNESS BETWEEN ECM AND ELECTRONIC THROTTLE CONTROL RELAY.</b> 1) Disconnect the connector from ECM. 2) Turn the ignition switch to ON. 3) Measure the voltage between electronic throttle control relay connector and chassis ground. <b>Connector &amp; terminal</b> <b>(B362) No. 6 (+) — Chassis ground (-):</b>	Is the voltage 10 V or more?	Repair the short circuit to power in harness between ECM and electronic throttle control relay.	Go to step 4.
<b>4 CHECK HARNESS BETWEEN ECM AND ELECTRONIC THROTTLE CONTROL RELAY.</b> 1) Turn the ignition switch to OFF. 2) Measure the resistance between electronic throttle control relay connector and chassis ground. <b>Connector &amp; terminal</b> <b>(B362) No. 6 — Chassis ground:</b> <b>(B362) No. 8 — Chassis ground:</b>	Is the resistance 1 M $\Omega$ or more?	Go to step 5.	Repair the ground short circuit of harness between ECM and electronic throttle control relay.
<b>5 CHECK HARNESS BETWEEN ECM AND ELECTRONIC THROTTLE CONTROL RELAY.</b> Measure the resistance between ECM and electronic throttle control relay connector. <b>Connector &amp; terminal</b> <b>(B135) No. 7 — (B362) No. 8:</b> <b>(B135) No. 17 — (B362) No. 6:</b>	Is the resistance less than 1 $\Omega$ ?	Repair the poor contact of ECM connector.	Repair the open circuit of harness between ECM and electronic throttle control relay.

# Diagnostic Procedure with Diagnostic Trouble Code (DTC)

ENGINE (DIAGNOSTICS)

## FE:DTC P2103 THROTTLE ACTUATOR CONTROL MOTOR CIRCUIT HIGH

### DTC DETECTING CONDITION:

- Immediately at fault recognition
- GENERAL DESCRIPTION <Ref. to GD(H6DO)-212, DTC P2103 THROTTLE ACTUATOR CONTROL MOTOR CIRCUIT HIGH, Diagnostic Trouble Code (DTC) Detecting Criteria.>

### CAUTION:

After servicing or replacing faulty parts, perform Clear Memory Mode <Ref. to EN(H6DO)(diag)-62, OPERATION, Clear Memory Mode.>, and Inspection Mode <Ref. to EN(H6DO)(diag)-47, PROCEDURE, Inspection Mode.>.

### WIRING DIAGRAM:

Engine electrical system <Ref. to WI-32, Engine Electrical System.>

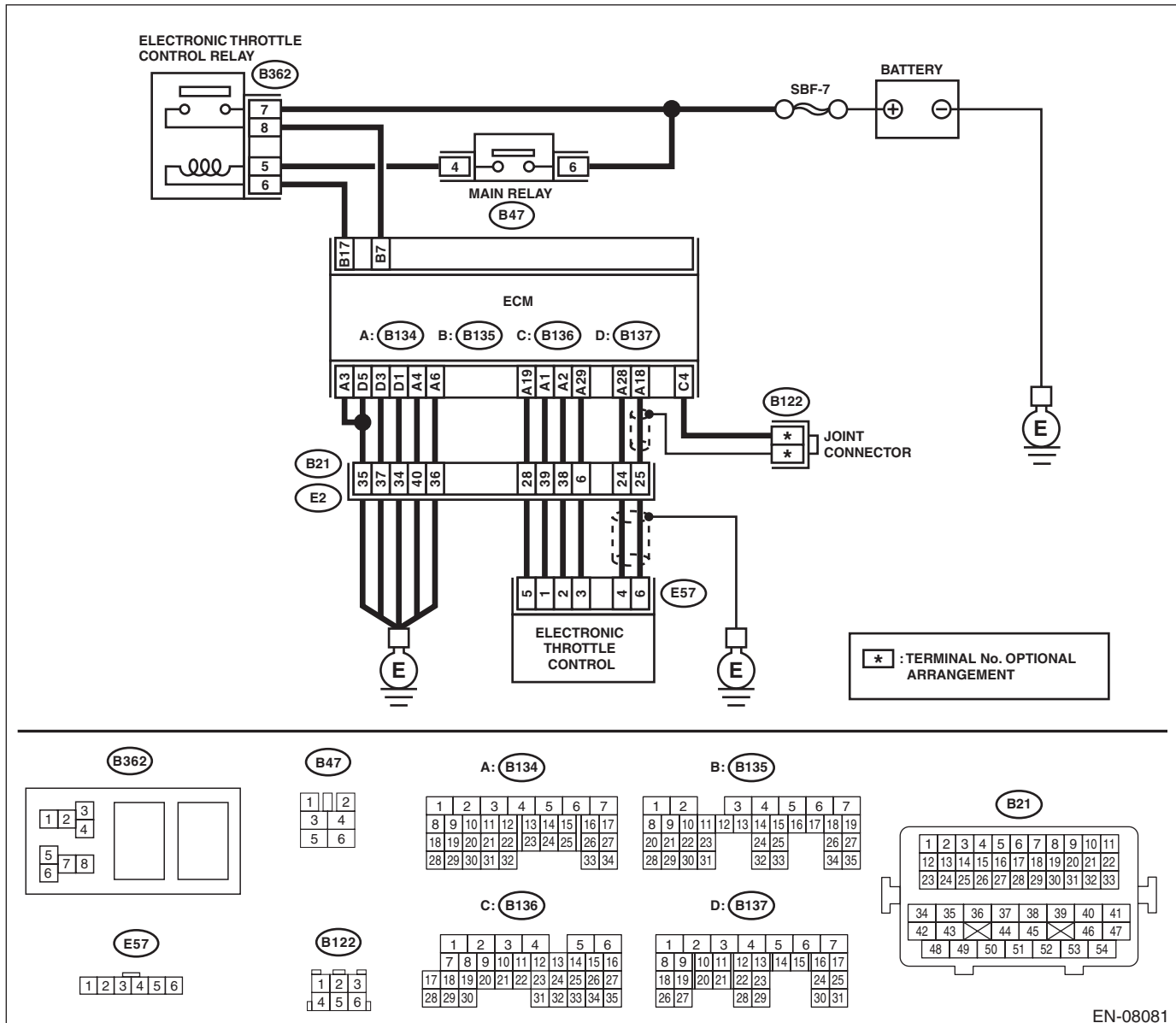

EN-08081

# Diagnostic Procedure with Diagnostic Trouble Code (DTC)

ENGINE (DIAGNOSTICS)

Step	Check	Yes	No
<b>1 CHECK ELECTRONIC THROTTLE CONTROL RELAY.</b> 1) Turn the ignition switch to OFF. 2) Remove the electronic throttle control relay. 3) Measure the resistance between electronic throttle control relay terminals. <i>Terminals</i> <i>No. 7 — No. 8:</i>	Is the resistance 1 MΩ or more?	Go to step 2.	Replace the electronic throttle control relay. <Ref. to EN(H6DO)(diag)-9, Electrical Component Location.>
<b>2 CHECK SHORT CIRCUIT OF ELECTRONIC THROTTLE CONTROL RELAY POWER SUPPLY.</b> 1) Turn the ignition switch to ON. 2) Measure the voltage between electronic throttle control relay connector and chassis ground. <i>Connector &amp; terminal</i> <i>(B362) No. 8 (+) — Chassis ground (-):</i>	Is the voltage 10 V or more?	Repair the short circuit to power in harness between ECM and electronic throttle control relay.	Go to step 3.
<b>3 CHECK HARNESS BETWEEN ECM AND ELECTRONIC THROTTLE CONTROL RELAY.</b> 1) Turn the ignition switch to OFF. 2) Disconnect the connector from ECM. 3) Measure the resistance between ECM and chassis ground. <i>Connector &amp; terminal</i> <i>(B135) No. 17 — Chassis ground:</i>	Is the resistance 1 MΩ or more?	Repair the poor contact of ECM connector.	Repair the ground short circuit of harness between ECM and electronic throttle control relay.

## FF: DTC P2109 THROTTLE/PEDAL POSITION SENSOR “A” MINIMUM STOP PERFORMANCE

NOTE:

For the diagnostic procedure, refer to DTC P2101. <Ref. to EN(H6DO)(diag)-328, DTC P2101 THROTTLE ACTUATOR CONTROL MOTOR CIRCUIT RANGE/PERFORMANCE, Diagnostic Procedure with Diagnostic Trouble Code (DTC).>

## FG: DTC P2119 THROTTLE ACTUATOR CONTROL THROTTLE BODY RANGE/PERFORMANCE

NOTE:

For the diagnostic procedure, refer to DTC P2101. <Ref. to EN(H6DO)(diag)-328, DTC P2101 THROTTLE ACTUATOR CONTROL MOTOR CIRCUIT RANGE/PERFORMANCE, Diagnostic Procedure with Diagnostic Trouble Code (DTC).>

## FH:DTC P2122 THROTTLE/PEDAL POSITION SENSOR/SWITCH “D” CIRCUIT LOW INPUT

### DTC DETECTING CONDITION:

- Immediately at fault recognition
- GENERAL DESCRIPTION <Ref. to GD(H6DO)-218, DTC P2122 THROTTLE/PEDAL POSITION SENSOR/SWITCH “D” CIRCUIT LOW INPUT, Diagnostic Trouble Code (DTC) Detecting Criteria.>

### TROUBLE SYMPTOM:

- Improper idling
- Poor driving performance

### CAUTION:

After servicing or replacing faulty parts, perform Clear Memory Mode <Ref. to EN(H6DO)(diag)-62, OPERATION, Clear Memory Mode.>, and Inspection Mode <Ref. to EN(H6DO)(diag)-47, PROCEDURE, Inspection Mode.>.

### WIRING DIAGRAM:

Engine electrical system <Ref. to WI-32, Engine Electrical System.>

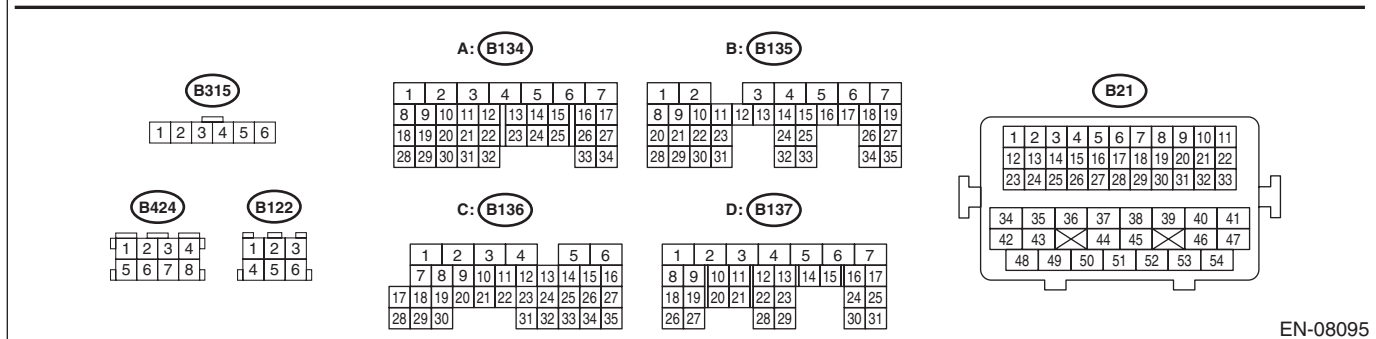
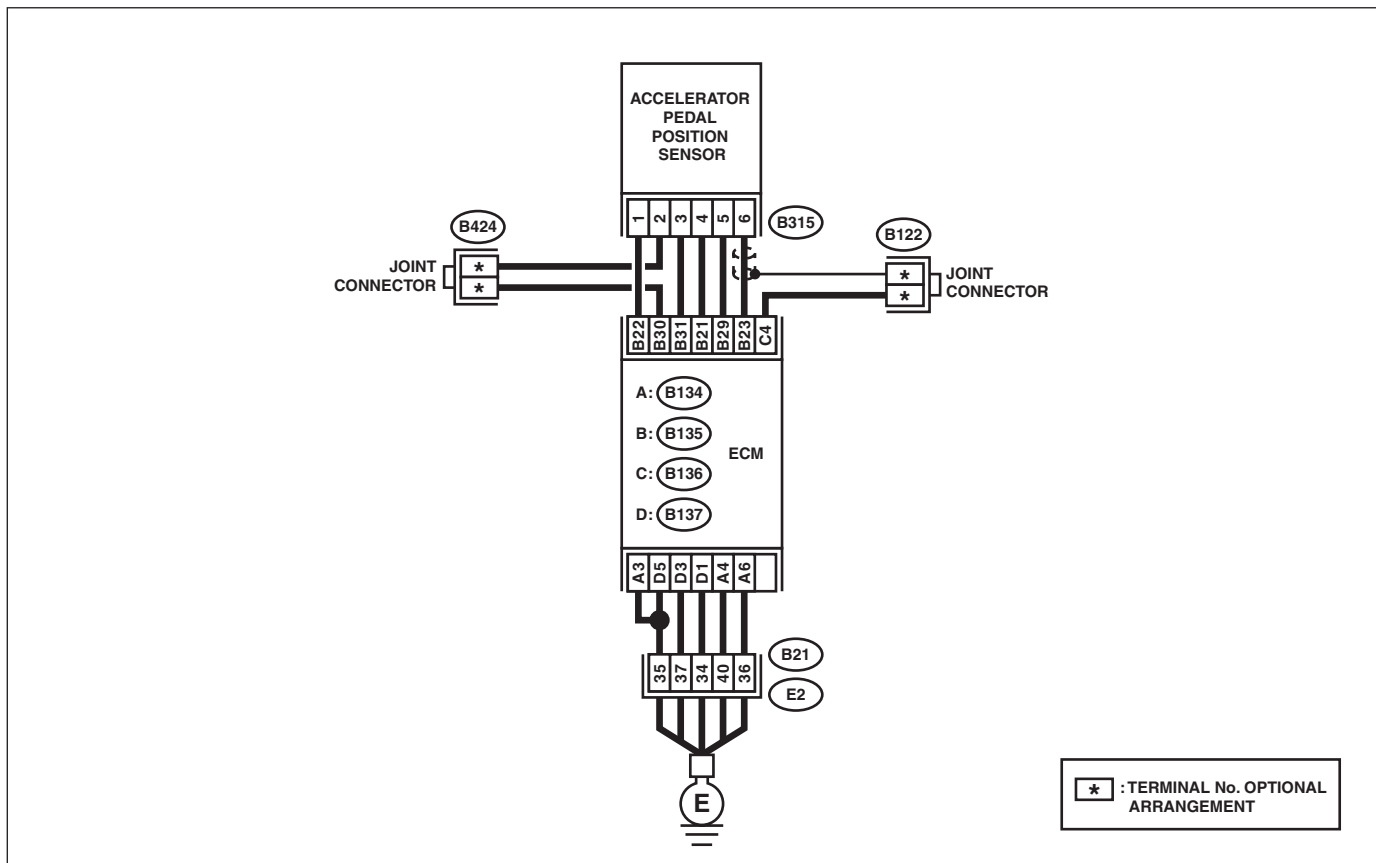

EN-08095

# Diagnostic Procedure with Diagnostic Trouble Code (DTC)

ENGINE (DIAGNOSTICS)

Step	Check	Yes	No
<p><b>1</b></p> <p><b>CHECK HARNESS BETWEEN ECM AND ACCELERATOR PEDAL POSITION SENSOR CONNECTOR.</b></p> <p>1) Turn the ignition switch to OFF.            2) Disconnect the connectors from ECM and accelerator pedal position sensor.            3) Measure the resistance between ECM and chassis ground.</p> <p><b>Connector &amp; terminal</b>  <b>(B135) No. 21 — Chassis ground:</b>  <b>(B135) No. 23 — Chassis ground:</b>  <b>(B135) No. 23 — (B136) No. 4:</b></p>	<p>Is the resistance 1 MΩ or more?</p>	<p>Go to step 2.</p>	<p>Repair the short circuit to ground in harness between ECM and accelerator pedal position sensor connector.</p>
<p><b>2</b></p> <p><b>CHECK SHORT CIRCUIT INSIDE THE ECM.</b></p> <p>1) Connect the connector to ECM.            2) Measure the resistance between accelerator pedal position sensor connector and chassis ground.</p> <p><b>Connector &amp; terminal</b>  <b>(B315) No. 6 — Chassis ground:</b></p>	<p>Is the resistance 1 MΩ or more?</p>	<p>Replace the accelerator pedal. &lt;Ref. to SP(H6DO)-4, Accelerator Pedal.&gt;</p>	<p>Repair the short circuit to ground in harness between ECM and accelerator pedal position sensor connector. Replace the ECM if defective. &lt;Ref. to FU(H6DO)-51, Engine Control Module (ECM).&gt;</p>



## FI: DTC P2123 THROTTLE/PEDAL POSITION SENSOR/SWITCH “D” CIRCUIT HIGH INPUT

### DTC DETECTING CONDITION:

- Immediately at fault recognition
- GENERAL DESCRIPTION <Ref. to GD(H6DO)-220, DTC P2123 THROTTLE/PEDAL POSITION SENSOR/SWITCH “D” CIRCUIT HIGH INPUT, Diagnostic Trouble Code (DTC) Detecting Criteria.>

### TROUBLE SYMPTOM:

- Improper idling
- Poor driving performance

### CAUTION:

After servicing or replacing faulty parts, perform Clear Memory Mode <Ref. to EN(H6DO)(diag)-62, OPERATION, Clear Memory Mode.>, and Inspection Mode <Ref. to EN(H6DO)(diag)-47, PROCEDURE, Inspection Mode.>.

### WIRING DIAGRAM:

Engine electrical system <Ref. to WI-32, Engine Electrical System.>

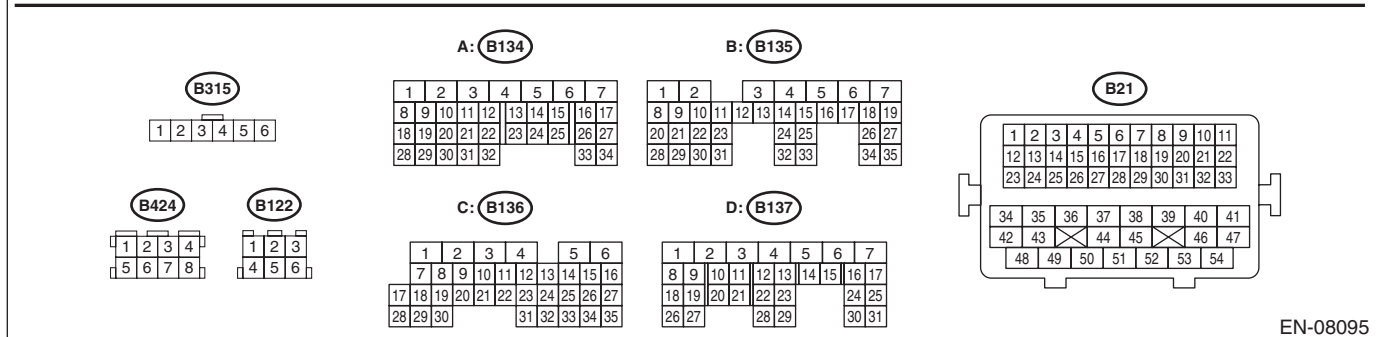
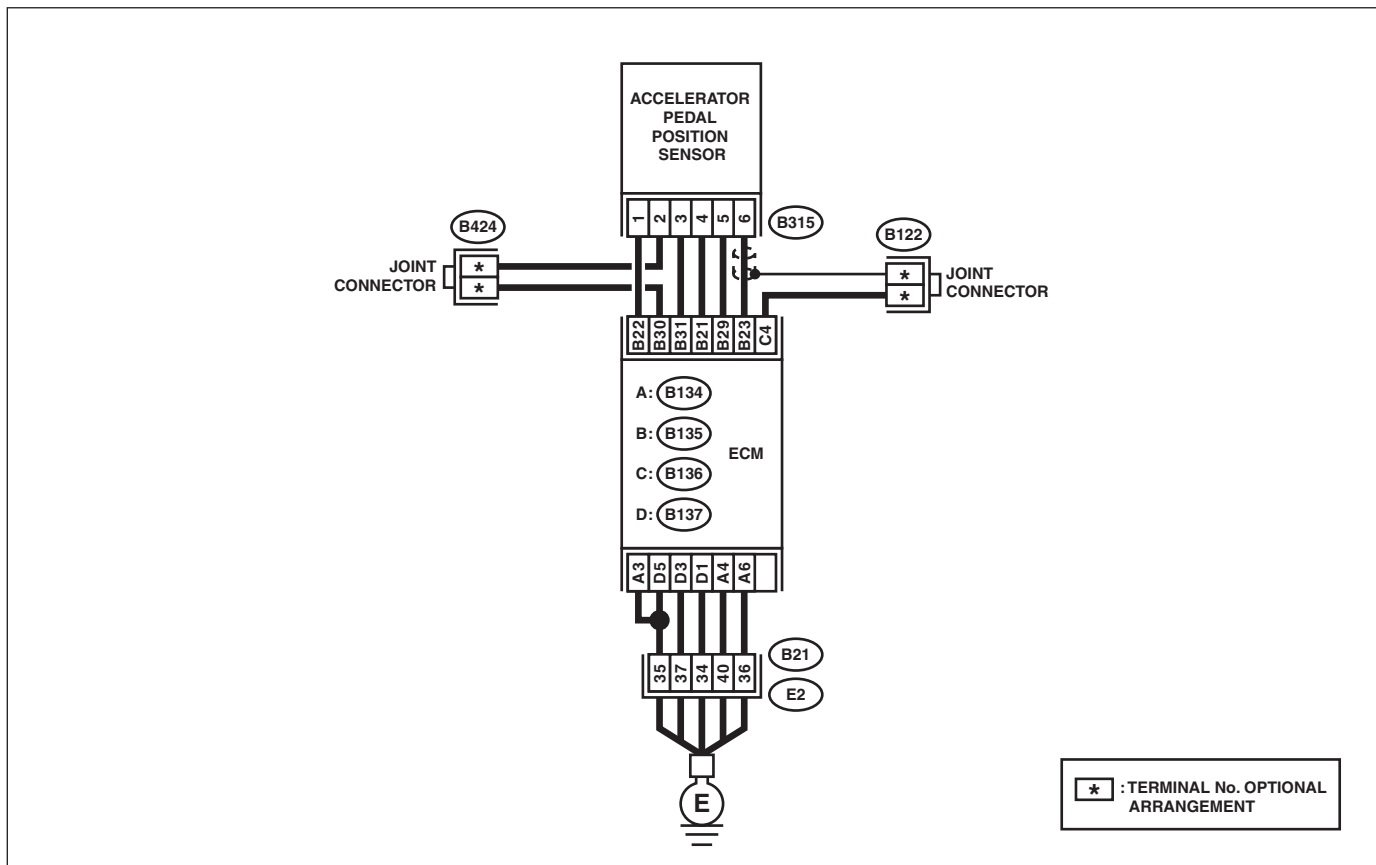

EN-08095

# Diagnostic Procedure with Diagnostic Trouble Code (DTC)

ENGINE (DIAGNOSTICS)

Step	Check	Yes	No
<p><b>1</b>    <b>CHECK HARNESS BETWEEN ECM AND ACCELERATOR PEDAL POSITION SENSOR CONNECTOR.</b></p> <p>1) Turn the ignition switch to OFF. 2) Disconnect the connectors from ECM and accelerator pedal position sensor. 3) Measure the resistance of harness between ECM and accelerator pedal position sensor connector.</p> <p><b>Connector &amp; terminal</b> <b>(B135) No. 23 — (B315) No. 6:</b> <b>(B135) No. 29 — (B315) No. 5:</b></p>	Is the resistance less than 1 Ω?	Go to step 2.	Repair the open circuit in harness between ECM and accelerator pedal position sensor connector.
<p><b>2</b>    <b>CHECK HARNESS BETWEEN ECM AND ACCELERATOR PEDAL POSITION SENSOR CONNECTOR.</b></p> <p>1) Connect the connector to ECM. 2) Measure the resistance between accelerator pedal position sensor connector and chassis ground.</p> <p><b>Connector &amp; terminal</b> <b>(B315) No. 5 — Chassis ground:</b></p>	Is the resistance less than 5 Ω?	Go to step 3.	Repair the harness and connector. <b>NOTE:</b> In this case, repair the following item: • Open circuit of harness between ECM and engine ground • Poor contact of ECM connector • Poor contact of coupling connector
<p><b>3</b>    <b>CHECK HARNESS BETWEEN ECM AND ACCELERATOR PEDAL POSITION SENSOR CONNECTOR.</b></p> <p>1) Turn the ignition switch to ON. 2) Measure the voltage between accelerator pedal position sensor connector and chassis ground.</p> <p><b>Connector &amp; terminal</b> <b>(B315) No. 6 (+) — Chassis ground (-):</b></p>	Is the voltage 5 V or more?	Repair the short circuit to power supply in the harness between the ECM and accelerator pedal position sensor connector.	Go to step 4.
<p><b>4</b>    <b>CHECK HARNESS BETWEEN ECM AND ACCELERATOR PEDAL POSITION SENSOR CONNECTOR.</b></p> <p>1) Turn the ignition switch to OFF. 2) Disconnect the connector from ECM. 3) Measure the resistance between ECM connectors.</p> <p><b>Connector &amp; terminal</b> <b>(B135) No. 21 — (B135) No. 23:</b></p>	Is the resistance 1 MΩ or more?	Repair the poor contact of accelerator pedal position sensor connector. Replace the accelerator pedal if defective. <Ref. to SP(H6DO)-4, Accelerator Pedal.>	Repair the short circuit to power supply in the harness between the ECM and accelerator pedal position sensor connector.

# Diagnostic Procedure with Diagnostic Trouble Code (DTC)

ENGINE (DIAGNOSTICS)

## FJ: DTC P2127 THROTTLE/PEDAL POSITION SENSOR/SWITCH "E" CIRCUIT LOW INPUT

### DTC DETECTING CONDITION:

- Immediately at fault recognition
- GENERAL DESCRIPTION <Ref. to GD(H6DO)-222, DTC P2127 THROTTLE/PEDAL POSITION SENSOR/SWITCH "E" CIRCUIT LOW INPUT, Diagnostic Trouble Code (DTC) Detecting Criteria.>

### TROUBLE SYMPTOM:

- Improper idling
- Poor driving performance

### CAUTION:

After servicing or replacing faulty parts, perform Clear Memory Mode <Ref. to EN(H6DO)(diag)-62, OPERATION, Clear Memory Mode.>, and Inspection Mode <Ref. to EN(H6DO)(diag)-47, PROCEDURE, Inspection Mode.>.

### WIRING DIAGRAM:

Engine electrical system <Ref. to WI-32, Engine Electrical System.>

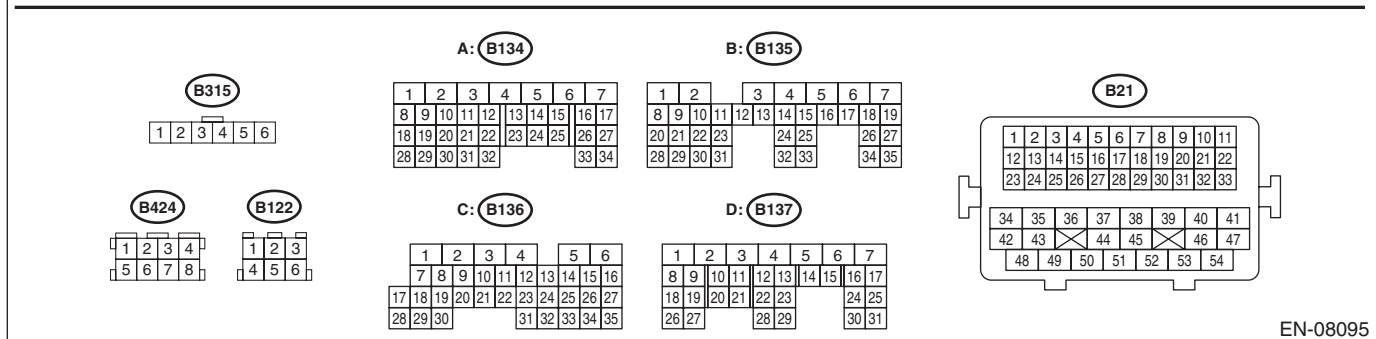
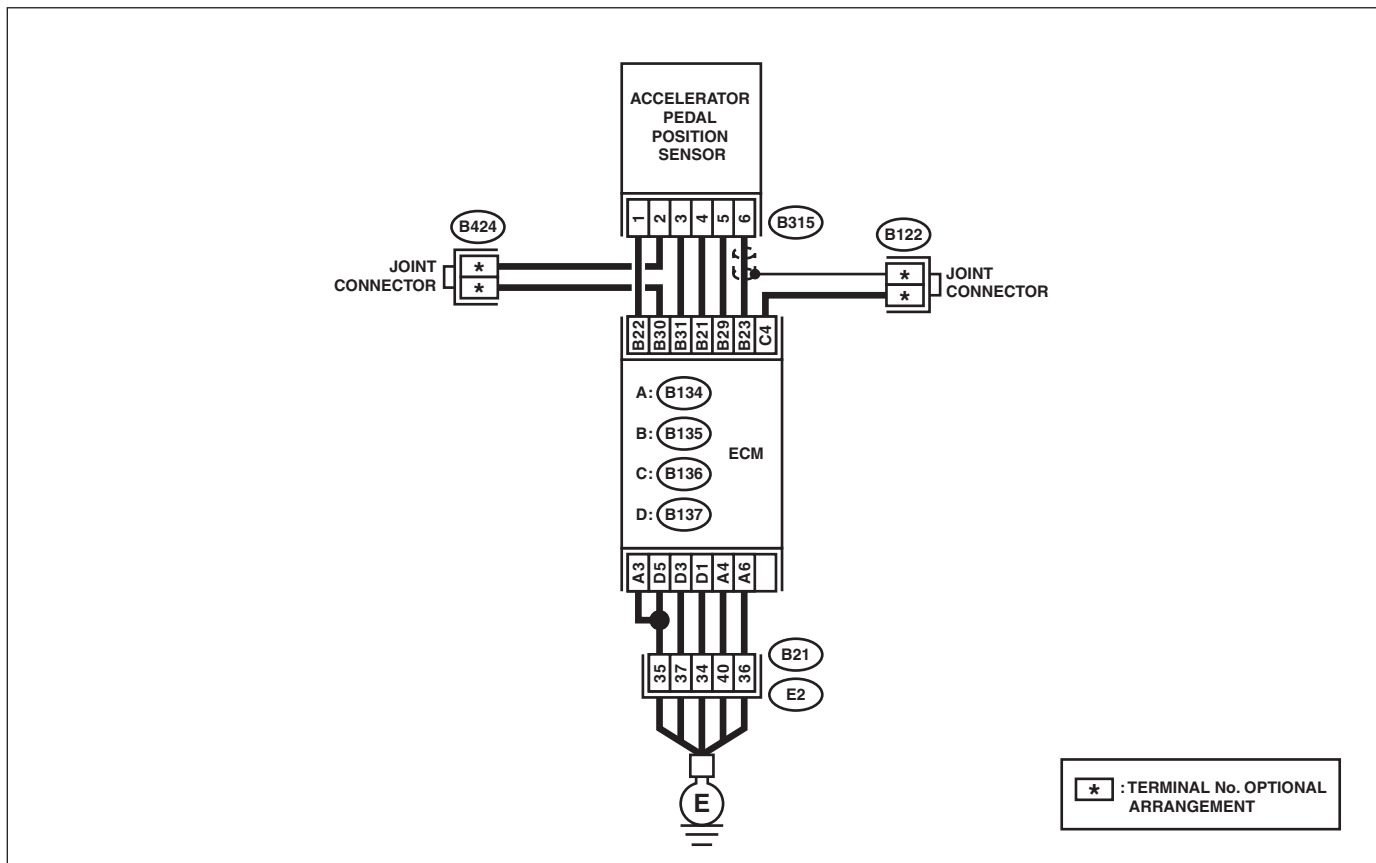

EN-08095

# Diagnostic Procedure with Diagnostic Trouble Code (DTC)

ENGINE (DIAGNOSTICS)

	Step	Check	Yes	No
<p><b>1</b></p> <p><b>CHECK HARNESS BETWEEN ECM AND ACCELERATOR PEDAL POSITION SENSOR CONNECTOR.</b></p> <p>1) Turn the ignition switch to OFF. 2) Disconnect the connectors from ECM and accelerator pedal position sensor. 3) Measure the resistance between ECM and chassis ground.</p> <p><b>Connector &amp; terminal</b> <b>(B135) No. 22 — Chassis ground:</b> <b>(B135) No. 31 — Chassis ground:</b></p>	<p>Is the resistance 1 MΩ or more?</p>	<p>Go to step 2.</p>	<p>Repair the short circuit to ground in harness between ECM and accelerator pedal position sensor connector.</p>	
<p><b>2</b></p> <p><b>CHECK SHORT CIRCUIT INSIDE THE ECM.</b></p> <p>1) Connect the connector to ECM. 2) Measure the resistance between accelerator pedal position sensor connector and chassis ground.</p> <p><b>Connector &amp; terminal</b> <b>(B315) No. 3 — Chassis ground:</b></p>	<p>Is the resistance 1 MΩ or more?</p>	<p>Replace the accelerator pedal. &lt;Ref. to SP(H6DO)-4, Accelerator Pedal.&gt;</p>	<p>Repair the short circuit to ground in harness between ECM and accelerator pedal position sensor connector. Replace the ECM if defective. &lt;Ref. to FU(H6DO)-51, Engine Control Module (ECM).&gt;</p>	

# Diagnostic Procedure with Diagnostic Trouble Code (DTC)

ENGINE (DIAGNOSTICS)

## FK:DTC P2128 THROTTLE/PEDAL POSITION SENSOR/SWITCH "E" CIRCUIT HIGH INPUT

### DTC DETECTING CONDITION:

- Immediately at fault recognition
- GENERAL DESCRIPTION <Ref. to GD(H6DO)-224, DTC P2128 THROTTLE/PEDAL POSITION SENSOR/SWITCH "E" CIRCUIT HIGH INPUT, Diagnostic Trouble Code (DTC) Detecting Criteria.>

### TROUBLE SYMPTOM:

- Improper idling
- Poor driving performance

### CAUTION:

After servicing or replacing faulty parts, perform Clear Memory Mode <Ref. to EN(H6DO)(diag)-62, OPERATION, Clear Memory Mode.>, and Inspection Mode <Ref. to EN(H6DO)(diag)-47, PROCEDURE, Inspection Mode.>.

### WIRING DIAGRAM:

Engine electrical system <Ref. to WI-32, Engine Electrical System.>

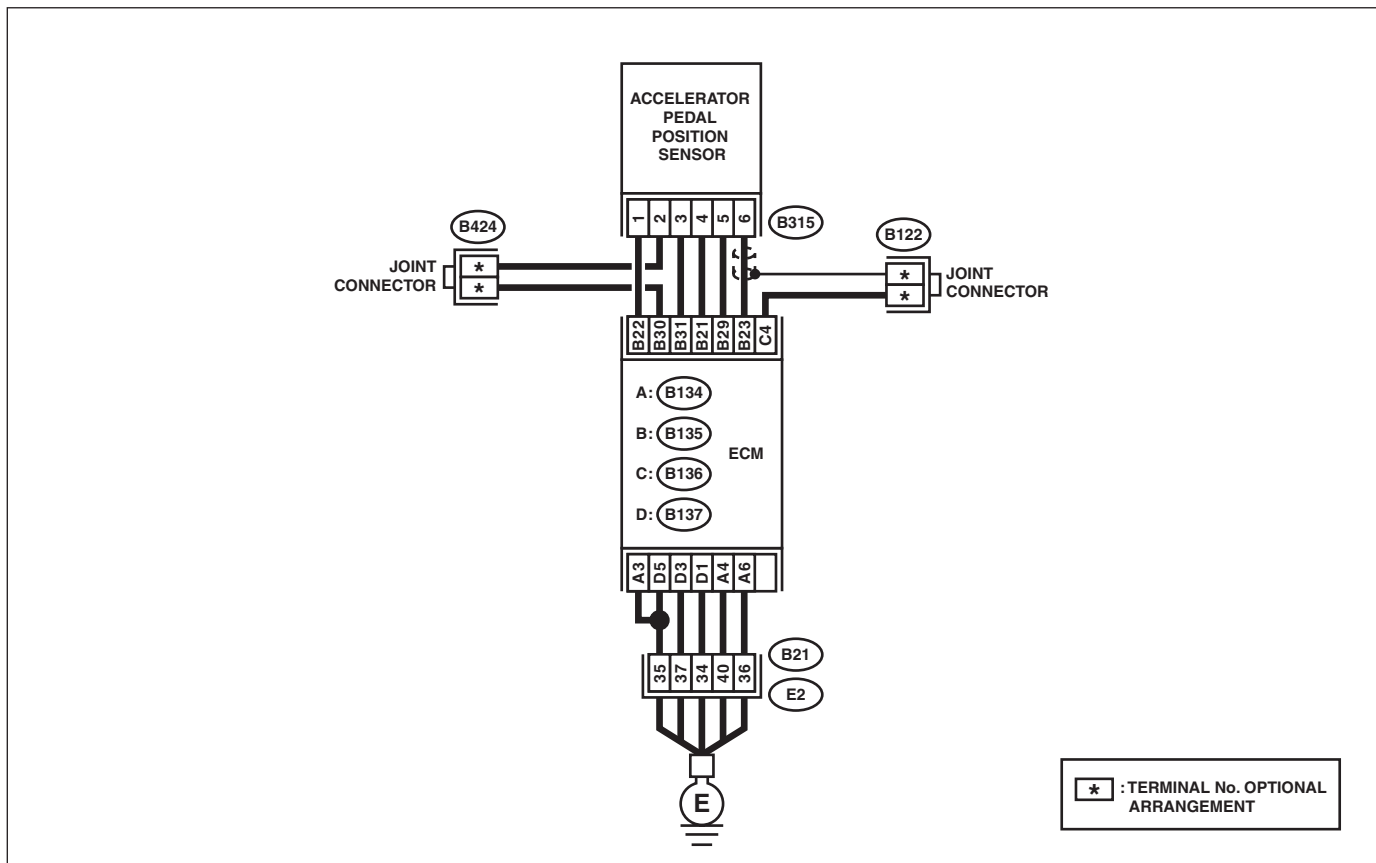

\* : TERMINAL No. OPTIONAL ARRANGEMENT

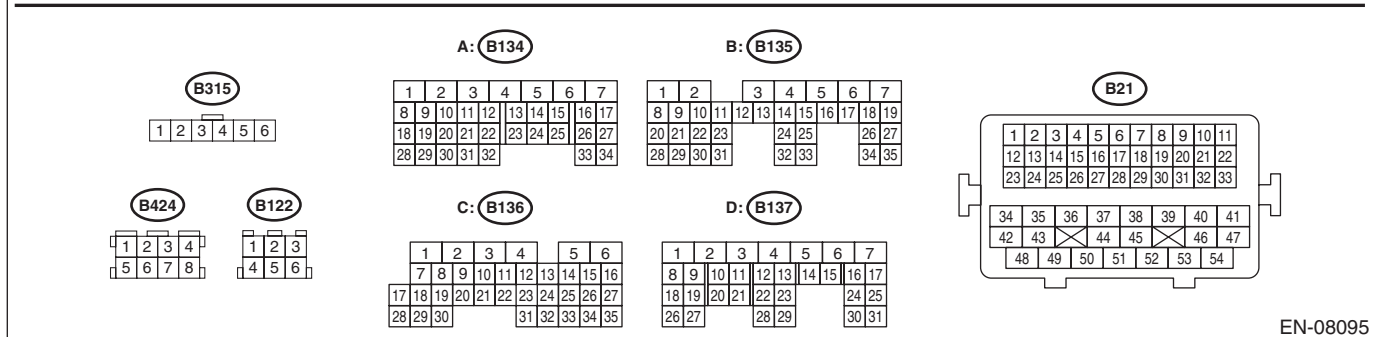

EN-08095

# Diagnostic Procedure with Diagnostic Trouble Code (DTC)

ENGINE (DIAGNOSTICS)

Step	Check	Yes	No
<p><b>1</b>     <b>CHECK HARNESS BETWEEN ECM AND ACCELERATOR PEDAL POSITION SENSOR CONNECTOR.</b></p> <p>1) Turn the ignition switch to OFF. 2) Disconnect the connectors from ECM and accelerator pedal position sensor. 3) Measure the resistance of harness between ECM and accelerator pedal position sensor connector.</p> <p><b>Connector &amp; terminal</b> <b>(B135) No. 31 — (B315) No. 3:</b> <b>(B135) No. 30 — (B315) No. 2:</b></p>	Is the resistance less than 1 Ω?	Go to step 2.	Repair the open circuit in harness between ECM and accelerator pedal position sensor connector.
<p><b>2</b>     <b>CHECK HARNESS BETWEEN ECM AND ACCELERATOR PEDAL POSITION SENSOR CONNECTOR.</b></p> <p>1) Connect the connector to ECM. 2) Measure the resistance between accelerator pedal position sensor connector and chassis ground.</p> <p><b>Connector &amp; terminal</b> <b>(B315) No. 2 — Chassis ground:</b></p>	Is the resistance less than 5 Ω?	Go to step 3.	Repair the harness and connector. NOTE: In this case, repair the following item: • Open circuit of harness between ECM and engine ground • Poor contact of ECM connector • Poor contact of coupling connector
<p><b>3</b>     <b>CHECK HARNESS BETWEEN ECM AND ACCELERATOR PEDAL POSITION SENSOR CONNECTOR.</b></p> <p>1) Turn the ignition switch to ON. 2) Measure the voltage between accelerator pedal position sensor connector and chassis ground.</p> <p><b>Connector &amp; terminal</b> <b>(B315) No. 3 (+) — Chassis ground (-):</b></p>	Is the voltage 5 V or more?	Repair the short circuit to power supply in the harness between the ECM and accelerator pedal position sensor connector.	Go to step 4.
<p><b>4</b>     <b>CHECK HARNESS BETWEEN ECM AND ACCELERATOR PEDAL POSITION SENSOR CONNECTOR.</b></p> <p>1) Turn the ignition switch to OFF. 2) Disconnect the connector from ECM. 3) Measure the resistance between ECM connectors.</p> <p><b>Connector &amp; terminal</b> <b>(B135) No. 22 — (B135) No. 31:</b></p>	Is the resistance 1 MΩ or more?	Repair the poor contact of accelerator pedal position sensor connector. Replace the accelerator pedal if defective. <Ref. to SP(H6DO)-4, Accelerator Pedal.>	Repair the short circuit to power supply in the harness between the ECM and accelerator pedal position sensor connector.

# Diagnostic Procedure with Diagnostic Trouble Code (DTC)

ENGINE (DIAGNOSTICS)

## FL:DTC P2135 THROTTLE/PEDAL POSITION SENSOR/SWITCH “A”/“B” VOLTAGE CORRELATION

### DTC DETECTING CONDITION:

- Immediately at fault recognition
- GENERAL DESCRIPTION <Ref. to GD(H6DO)-226, DTC P2135 THROTTLE/PEDAL POSITION SENSOR/SWITCH “A”/“B” VOLTAGE CORRELATION, Diagnostic Trouble Code (DTC) Detecting Criteria.>

### TROUBLE SYMPTOM:

- Improper idling
- Poor driving performance

### CAUTION:

After servicing or replacing faulty parts, perform Clear Memory Mode <Ref. to EN(H6DO)(diag)-62, OPERATION, Clear Memory Mode.>, and Inspection Mode <Ref. to EN(H6DO)(diag)-47, PROCEDURE, Inspection Mode.>.

### WIRING DIAGRAM:

Engine electrical system <Ref. to WI-32, Engine Electrical System.>

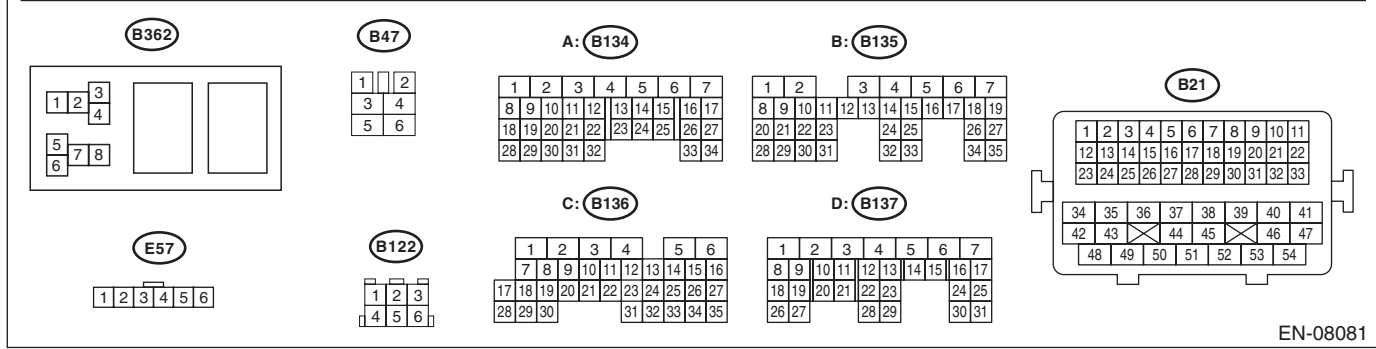
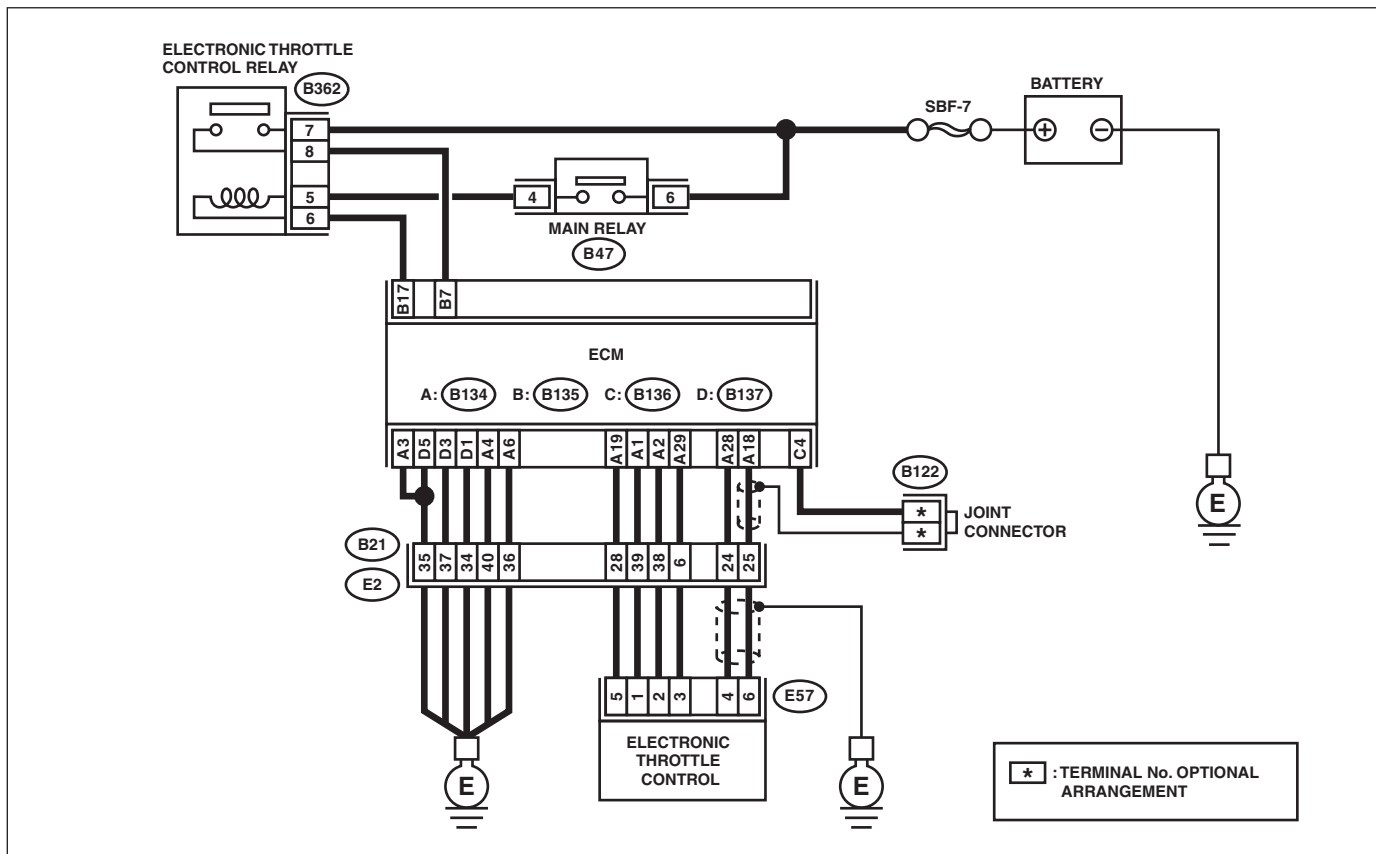

EN-08081

# Diagnostic Procedure with Diagnostic Trouble Code (DTC)

## ENGINE (DIAGNOSTICS)

Step	Check	Yes	No
<p><b>1 CHECK HARNESS BETWEEN ECM AND ELECTRONIC THROTTLE CONTROL.</b></p> <p>1) Turn the ignition switch to OFF. 2) Disconnect the connectors from ECM and electronic throttle control. 3) Measure the resistance between ECM and chassis ground.</p> <p><b>Connector &amp; terminal</b> <b>(B134) No. 19 — Chassis ground:</b> <b>(B134) No. 18 — Chassis ground:</b> <b>(B134) No. 18 — (B136) No. 4:</b> <b>(B134) No. 28 — Chassis ground:</b></p>	Is the resistance 1 MΩ or more?	Go to step 2.	Repair the short circuit to ground in harness between ECM and electronic throttle control connector.
<p><b>2 CHECK SHORT CIRCUIT INSIDE THE ECM.</b></p> <p>1) Connect the connector to ECM. 2) Measure the resistance between electronic throttle control connector and engine ground.</p> <p><b>Connector &amp; terminal</b> <b>(E57) No. 6 — Engine ground:</b> <b>(E57) No. 4 — Engine ground:</b></p>	Is the resistance 1 MΩ or more?	Go to step 3.	Repair the short circuit to ground in harness between ECM and electronic throttle control connector. Replace the ECM if defective. <Ref. to FU(H6DO)-51, Engine Control Module (ECM).>
<p><b>3 CHECK HARNESS BETWEEN ECM AND ELECTRONIC THROTTLE CONTROL.</b></p> <p>1) Disconnect the connector from ECM. 2) Measure the resistance of harness between ECM and electronic throttle control connector.</p> <p><b>Connector &amp; terminal</b> <b>(B134) No. 18 — (E57) No. 6:</b> <b>(B134) No. 28 — (E57) No. 4:</b> <b>(B134) No. 29 — (E57) No. 3:</b></p>	Is the resistance less than 1 Ω?	Go to step 4.	Repair the harness and connector. <b>NOTE:</b> In this case, repair the following item: • Open circuit in harness between ECM and electronic throttle control connector • Poor contact of coupling connector
<p><b>4 CHECK HARNESS BETWEEN ECM AND ELECTRONIC THROTTLE CONTROL.</b></p> <p>1) Connect the connector to ECM. 2) Measure the resistance between electronic throttle control connector and engine ground.</p> <p><b>Connector &amp; terminal</b> <b>(E57) No. 3 — Engine ground:</b></p>	Is the resistance less than 5 Ω?	Go to step 5.	Repair the harness and connector. <b>NOTE:</b> In this case, repair the following item: • Open circuit of harness between ECM and engine ground • Poor contact of ECM connector • Poor contact of coupling connector
<p><b>5 CHECK HARNESS BETWEEN ECM AND ELECTRONIC THROTTLE CONTROL.</b></p> <p>1) Turn the ignition switch to ON. 2) Measure the voltage between electronic throttle control connector and engine ground.</p> <p><b>Connector &amp; terminal</b> <b>(E57) No. 6 (+) — Engine ground (-):</b> <b>(E57) No. 4 (+) — Engine ground (-):</b></p>	Is the voltage 5 V or more?	Repair the short circuit to power in harness between ECM and electronic throttle control connector.	Go to step 6.



# Diagnostic Procedure with Diagnostic Trouble Code (DTC)

ENGINE (DIAGNOSTICS)

Step	Check	Yes	No
<b>6</b> <b>CHECK HARNESS BETWEEN ECM AND ELECTRONIC THROTTLE CONTROL.</b> 1) Turn the ignition switch to OFF. 2) Disconnect the connector from ECM. 3) Measure the resistance between ECM connectors. <b>Connector &amp; terminal</b> <b>(B134) No. 19 — (B134) No. 18:</b> <b>(B134) No. 19 — (B134) No. 28:</b>	Is the resistance 1 M $\Omega$ or more?	Repair the poor contact of electronic throttle control connector. Replace the electronic throttle control if defective. <Ref. to FU(H6DO)-19, Throttle Body.>	Repair the short circuit to power in harness between ECM and electronic throttle control connector.

# Diagnostic Procedure with Diagnostic Trouble Code (DTC)

ENGINE (DIAGNOSTICS)

## FM:DTC P2138 THROTTLE/PEDAL POSITION SENSOR/SWITCH “D”/“E” VOLTAGE CORRELATION

### DTC DETECTING CONDITION:

- Immediately at fault recognition
- GENERAL DESCRIPTION <Ref. to GD(H6DO)-228, DTC P2138 THROTTLE/PEDAL POSITION SENSOR/SWITCH “D”/“E” VOLTAGE CORRELATION, Diagnostic Trouble Code (DTC) Detecting Criteria.>

### CAUTION:

After servicing or replacing faulty parts, perform Clear Memory Mode <Ref. to EN(H6DO)(diag)-62, OPERATION, Clear Memory Mode.>, and Inspection Mode <Ref. to EN(H6DO)(diag)-47, PROCEDURE, Inspection Mode.>.

### TROUBLE SYMPTOM:

- Improper idling
- Poor driving performance

### WIRING DIAGRAM:

Engine electrical system <Ref. to WI-32, Engine Electrical System.>

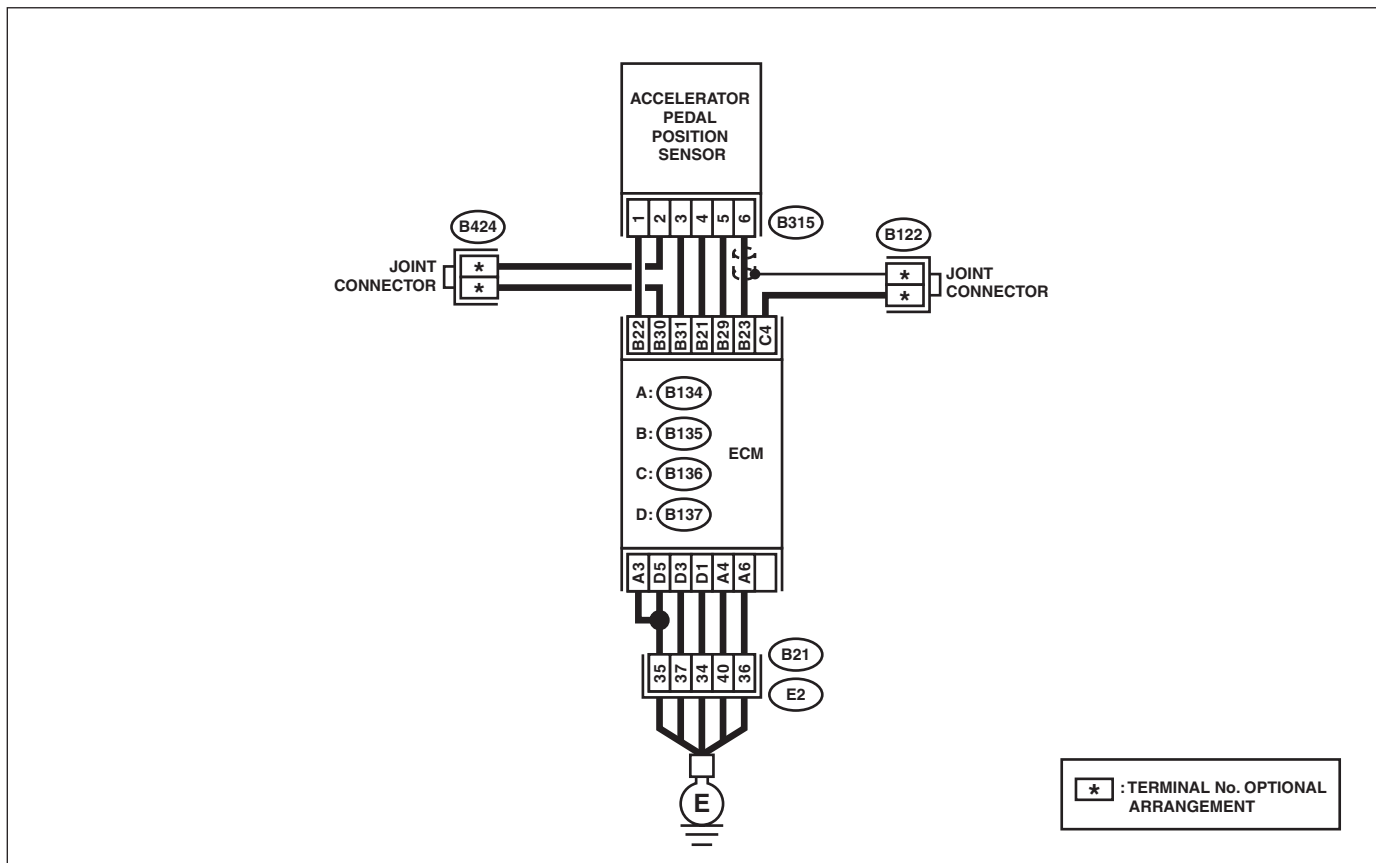

\* : TERMINAL No. OPTIONAL ARRANGEMENT

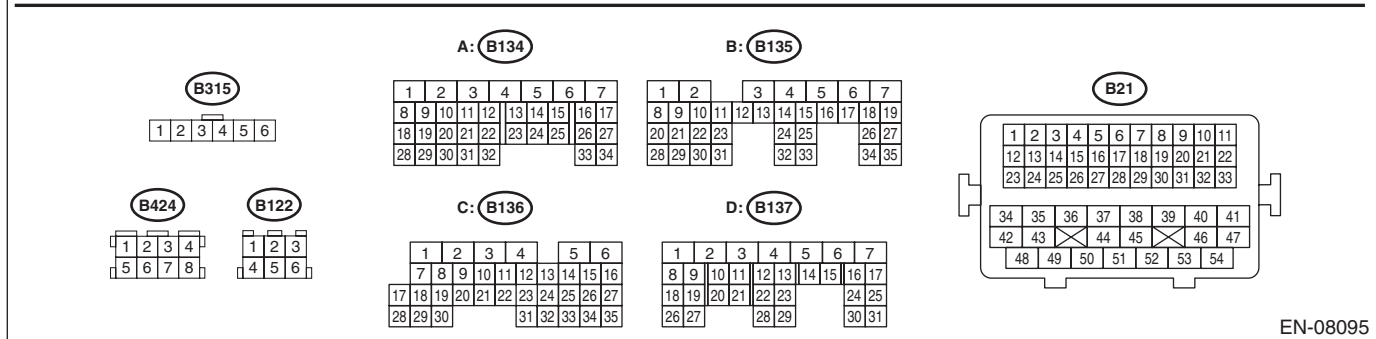

EN-08095

# Diagnostic Procedure with Diagnostic Trouble Code (DTC)

ENGINE (DIAGNOSTICS)

	Step	Check	Yes	No
1	<p><b>CHECK ACCELERATOR PEDAL POSITION SENSOR OUTPUT.</b></p> <p>1) Turn the ignition switch to ON. 2) Measure the voltage between ECM and chassis ground.</p> <p><b>Connector &amp; terminal</b> <b>Main accelerator pedal position sensor signal</b> <b>(B135) No. 23 (+) — Chassis ground (-):</b> <b>Accelerator pedal position sensor signal</b> <b>(B135) No. 31 (+) — Chassis ground (-):</b></p>	<p>Is the difference in measured values for the main accelerator pedal position sensor signal and the sub accelerator pedal position sensor signal 0 V?</p>	<p>Go to step 3.</p>	<p>Go to step 2.</p>
2	<p><b>CHECK ACCELERATOR PEDAL POSITION SENSOR OUTPUT.</b></p> <p>1) Measure the voltage between accelerator pedal position sensor connector and chassis ground.</p> <p><b>Connector &amp; terminal</b> <b>(B315) No. 6 (+) — Chassis ground (-):</b> <b>(B315) No. 3 (+) — Chassis ground (-):</b></p>	<p>Is the difference in measured values for the main accelerator pedal position sensor signal and the sub accelerator pedal position sensor signal 0 V?</p>	<p>Replace the accelerator pedal. &lt;Ref. to SP(H6DO)-4, Accelerator Pedal.&gt;</p>	<p>Repair the harness and connector. <b>NOTE:</b> In this case, repair the following item:</p> <ul style="list-style-type: none"> <li>• Open circuit in harness between ECM and accelerator pedal position sensor connector</li> <li>• Short circuit to ground in harness between ECM and accelerator pedal position sensor connector</li> <li>• Poor contact of coupling connector</li> </ul>
3	<p><b>CHECK HARNESS BETWEEN ECM AND ACCELERATOR PEDAL POSITION SENSOR CONNECTOR.</b></p> <p>Measure the resistance of harness between the accelerator pedal position sensor connector and chassis ground.</p> <p><b>Connector &amp; terminal</b> <b>(B315) No. 5 — Chassis ground:</b> <b>(B315) No. 2 — Chassis ground:</b></p>	<p>Is the resistance less than 5 Ω?</p>	<p>Repair the poor contact of ECM connector.</p>	<p>Repair the harness and connector. <b>NOTE:</b> In this case, repair the following item:</p> <ul style="list-style-type: none"> <li>• Open circuit in harness between ECM and accelerator pedal position sensor connector</li> <li>• Open circuit of harness between ECM and engine ground</li> <li>• Poor contact of ECM connector</li> <li>• Poor contact of coupling connector</li> </ul>

# Diagnostic Procedure with Diagnostic Trouble Code (DTC)

ENGINE (DIAGNOSTICS)

## FN:DTC P2195 O2 SENSOR SIGNAL BIASED/STUCK LEAN (BANK 1 SENSOR 1)

### DTC DETECTING CONDITION:

- Detected when two consecutive driving cycles with fault occur.
- GENERAL DESCRIPTION <Ref. to GD(H6DO)-230, DTC P2195 O2 SENSOR SIGNAL BIASED/STUCK LEAN (BANK 1 SENSOR 1), Diagnostic Trouble Code (DTC) Detecting Criteria.>

### CAUTION:

After servicing or replacing faulty parts, perform Clear Memory Mode <Ref. to EN(H6DO)(diag)-62, OPERATION, Clear Memory Mode.>, and Inspection Mode <Ref. to EN(H6DO)(diag)-47, PROCEDURE, Inspection Mode.>.

### WIRING DIAGRAM:

Engine electrical system <Ref. to WI-32, Engine Electrical System.>

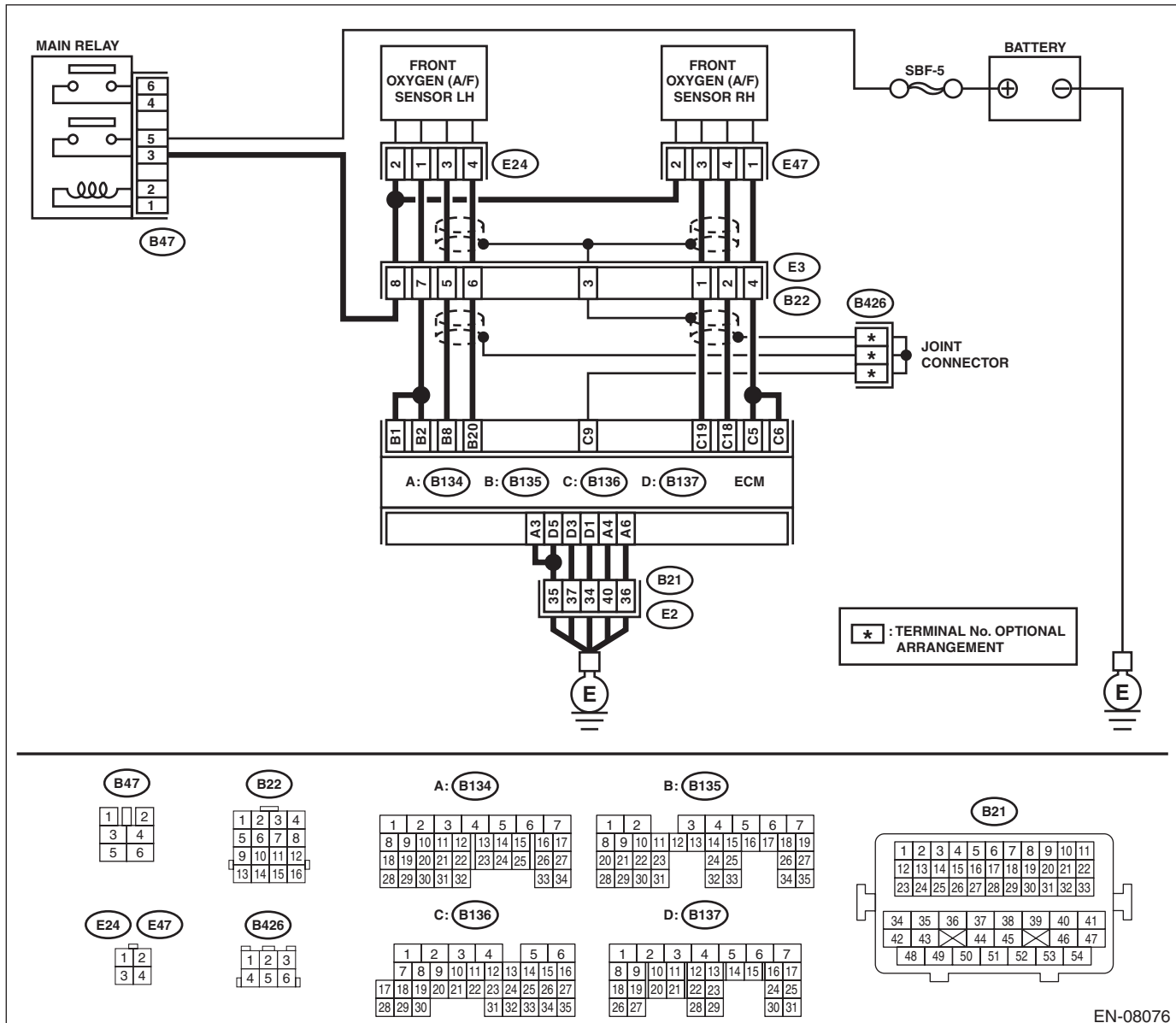

EN-08076

# Diagnostic Procedure with Diagnostic Trouble Code (DTC)

ENGINE (DIAGNOSTICS)

	Step	Check	Yes	No
1	<b>CHECK FRONT OXYGEN (A/F) SENSOR CONNECTOR AND COUPLING CONNECTOR.</b>	Has water entered the connector?	Completely remove any water inside.	Go to step 2.
2	<b>CHECK HARNESS BETWEEN ECM AND FRONT OXYGEN (A/F) SENSOR CONNECTOR.</b> 1) Turn the ignition switch to OFF. 2) Disconnect the connectors from ECM and front oxygen (A/F) sensor. 3) Measure the resistance of harness between ECM and front oxygen (A/F) sensor connector. <b>Connector &amp; terminal</b> <b>(B136) No. 19 — (E47) No. 3:</b> <b>(B136) No. 18 — (E47) No. 4:</b>	Is the resistance less than 1 $\Omega$ ?	Go to step 3.	Repair the harness and connector. <b>NOTE:</b> In this case, repair the following item: • Open circuit in harness between ECM and front oxygen (A/F) sensor connector • Poor contact of coupling connector
3	<b>CHECK FOR POOR CONTACT.</b> Check for poor contact of the front oxygen (A/F) sensor connector.	Is there poor contact of front oxygen (A/F) sensor connector?	Repair the poor contact of front oxygen (A/F) sensor connector.	Replace the front oxygen (A/F) sensor. <Ref. to FU(H6DO)-48, Front Oxygen (A/F) Sensor.>

# Diagnostic Procedure with Diagnostic Trouble Code (DTC)

ENGINE (DIAGNOSTICS)

## FO:DTC P2196 O2 SENSOR SIGNAL BIASED/STUCK RICH (BANK 1 SENSOR 1)

### DTC DETECTING CONDITION:

- Detected when two consecutive driving cycles with fault occur.
- GENERAL DESCRIPTION <Ref. to GD(H6DO)-232, DTC P2196 O2 SENSOR SIGNAL BIASED/STUCK RICH (BANK 1 SENSOR 1), Diagnostic Trouble Code (DTC) Detecting Criteria.>

### CAUTION:

After servicing or replacing faulty parts, perform Clear Memory Mode <Ref. to EN(H6DO)(diag)-62, OPERATION, Clear Memory Mode.>, and Inspection Mode <Ref. to EN(H6DO)(diag)-47, PROCEDURE, Inspection Mode.>.

### WIRING DIAGRAM:

Engine electrical system <Ref. to WI-32, Engine Electrical System.>

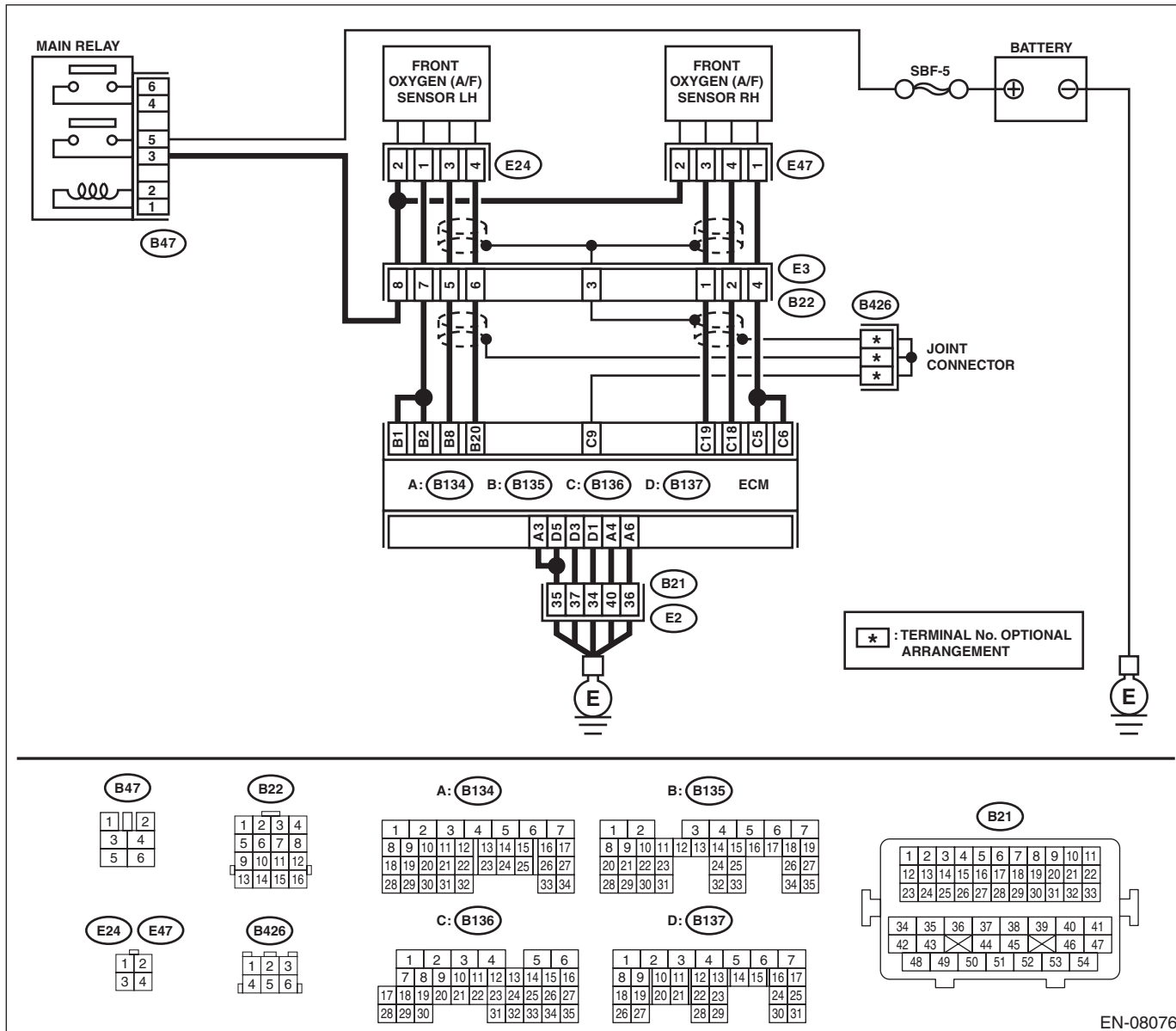

EN-08076

# Diagnostic Procedure with Diagnostic Trouble Code (DTC)

ENGINE (DIAGNOSTICS)

Step	Check	Yes	No
1	<b>CHECK FRONT OXYGEN (A/F) SENSOR CONNECTOR AND COUPLING CONNECTOR.</b>	Has water entered the connector?	Completely remove any water inside.
2	<b>CHECK HARNESS BETWEEN ECM AND FRONT OXYGEN (A/F) SENSOR CONNECTOR.</b> 1) Turn the ignition switch to OFF. 2) Disconnect the connector from ECM. 3) Measure the resistance between ECM and chassis ground. <b>Connector &amp; terminal</b> <b>(B136) No. 19 — Chassis ground:</b> <b>(B136) No. 18 — Chassis ground:</b>	Is the resistance 1 MΩ or more?	Go to step 3. Repair the ground short circuit of harness between ECM and front oxygen (A/F) sensor connector.
3	<b>CHECK OUTPUT SIGNAL FOR ECM.</b> 1) Connect the connector to ECM. 2) Turn the ignition switch to ON. 3) Measure the voltage between ECM and chassis ground. <b>Connector &amp; terminal</b> <b>(B136) No. 19 (+) — Chassis ground (-):</b>	Is the voltage 4.5 V or more?	Go to step 5. Go to step 4.
4	<b>CHECK OUTPUT SIGNAL FOR ECM.</b> Measure the voltage between ECM and chassis ground. <b>Connector &amp; terminal</b> <b>(B136) No. 18 (+) — Chassis ground (-):</b>	Is the voltage 4.95 V or more?	Go to step 5. Replace the front oxygen (A/F) sensor. <Ref. to FU(H6DO)-48, Front Oxygen (A/F) Sensor.>
5	<b>CHECK OUTPUT SIGNAL FOR ECM.</b> Measure the voltage between ECM and chassis ground. <b>Connector &amp; terminal</b> <b>(B136) No. 19 (+) — Chassis ground (-):</b> <b>(B136) No. 18 (+) — Chassis ground (-):</b>	Is the voltage 8 V or more?	Repair the short circuit to power in the harness between ECM and front oxygen (A/F) sensor connector. After repair, replace the ECM. <Ref. to FU(H6DO)-51, Engine Control Module (ECM).> Repair the poor contact of ECM connector.

# Diagnostic Procedure with Diagnostic Trouble Code (DTC)

ENGINE (DIAGNOSTICS)

## FP:DTC P2197 O2 SENSOR SIGNAL BIASED/STUCK LEAN (BANK 2 SENSOR 1)

### DTC DETECTING CONDITION:

- Detected when two consecutive driving cycles with fault occur.
- GENERAL DESCRIPTION <Ref. to GD(H6DO)-234, DTC P2197 O2 SENSOR SIGNAL BIASED/STUCK LEAN (BANK 2 SENSOR 1), Diagnostic Trouble Code (DTC) Detecting Criteria.>

### CAUTION:

After servicing or replacing faulty parts, perform Clear Memory Mode <Ref. to EN(H6DO)(diag)-62, OPERATION, Clear Memory Mode.>, and Inspection Mode <Ref. to EN(H6DO)(diag)-47, PROCEDURE, Inspection Mode.>.

### WIRING DIAGRAM:

Engine electrical system <Ref. to WI-32, Engine Electrical System.>

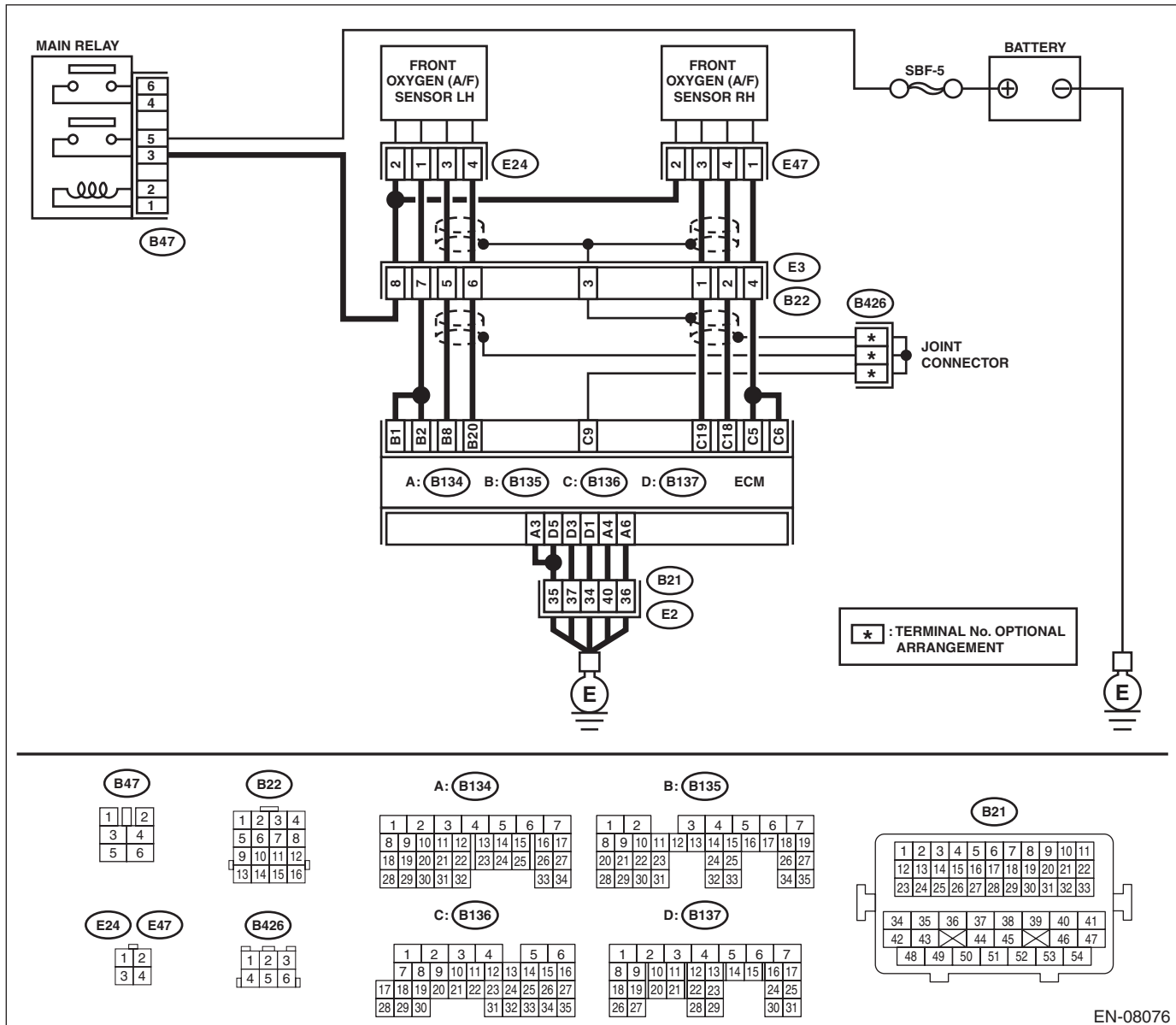

EN-08076



# Diagnostic Procedure with Diagnostic Trouble Code (DTC)

ENGINE (DIAGNOSTICS)

Step	Check	Yes	No
<b>1</b> <b>CHECK FRONT OXYGEN (A/F) SENSOR CONNECTOR AND COUPLING CONNECTOR.</b>	Has water entered the connector?	Completely remove any water inside.	Go to step 2.
<b>2</b> <b>CHECK HARNESS BETWEEN ECM AND FRONT OXYGEN (A/F) SENSOR CONNECTOR.</b> 1) Turn the ignition switch to OFF. 2) Disconnect the connectors from ECM and front oxygen (A/F) sensor. 3) Measure the resistance of harness between ECM and front oxygen (A/F) sensor connector. <b>Connector &amp; terminal</b> <b>(B135) No. 8 — (E24) No. 3:</b> <b>(B135) No. 20 — (E24) No. 4:</b>	Is the resistance less than 1 Ω?	Go to step 3.	Repair the harness and connector. NOTE: In this case, repair the following item: • Open circuit in harness between ECM and front oxygen (A/F) sensor connector • Poor contact of coupling connector
<b>3</b> <b>CHECK FOR POOR CONTACT.</b> Check for poor contact of the front oxygen (A/F) sensor connector.	Is there poor contact of front oxygen (A/F) sensor connector?	Repair the poor contact of front oxygen (A/F) sensor connector.	Replace the front oxygen (A/F) sensor. <Ref. to FU(H6DO)-48, Front Oxygen (A/F) Sensor.>

# Diagnostic Procedure with Diagnostic Trouble Code (DTC)

ENGINE (DIAGNOSTICS)

## FQ:DTC P2198 O2 SENSOR SIGNAL BIASED/STUCK RICH (BANK 2 SENSOR 1)

### DTC DETECTING CONDITION:

- Detected when two consecutive driving cycles with fault occur.
- GENERAL DESCRIPTION <Ref. to GD(H6DO)-234, DTC P2198 O2 SENSOR SIGNAL BIASED/STUCK RICH (BANK 2 SENSOR 1), Diagnostic Trouble Code (DTC) Detecting Criteria.>

### CAUTION:

After servicing or replacing faulty parts, perform Clear Memory Mode <Ref. to EN(H6DO)(diag)-62, OPERATION, Clear Memory Mode.>, and Inspection Mode <Ref. to EN(H6DO)(diag)-47, PROCEDURE, Inspection Mode.>.

### WIRING DIAGRAM:

Engine electrical system <Ref. to WI-32, Engine Electrical System.>

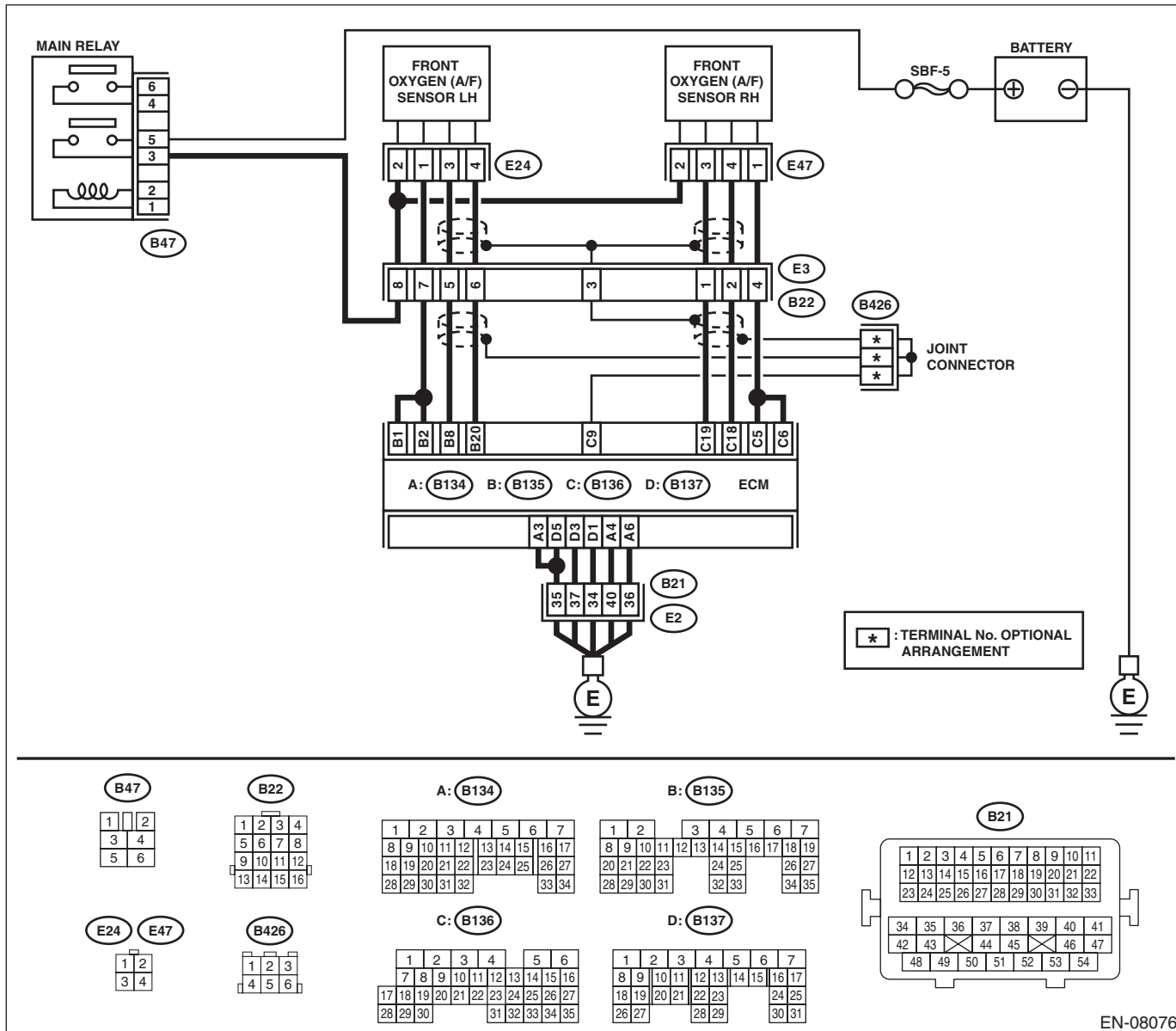

EN-08076

# Diagnostic Procedure with Diagnostic Trouble Code (DTC)

ENGINE (DIAGNOSTICS)

Step	Check	Yes	No
1	<b>CHECK FRONT OXYGEN (A/F) SENSOR CONNECTOR AND COUPLING CONNECTOR.</b>	Has water entered the connector?	Completely remove any water inside. Go to step 2.
2	<b>CHECK HARNESS BETWEEN ECM AND FRONT OXYGEN (A/F) SENSOR CONNECTOR.</b> 1) Turn the ignition switch to OFF. 2) Disconnect the connector from ECM. 3) Measure the resistance between ECM and chassis ground. <b>Connector &amp; terminal</b> <b>(B135) No. 8 — Chassis ground:</b> <b>(B135) No. 20 — Chassis ground:</b>	Is the resistance 1 MΩ or more?	Go to step 3. Repair the ground short circuit of harness between ECM and front oxygen (A/F) sensor connector.
3	<b>CHECK OUTPUT SIGNAL FOR ECM.</b> 1) Connect the connector to ECM. 2) Turn the ignition switch to ON. 3) Measure the voltage between ECM and chassis ground. <b>Connector &amp; terminal</b> <b>(B135) No. 8 (+) — Chassis ground (-):</b>	Is the voltage 4.5 V or more?	Go to step 5. Go to step 4.
4	<b>CHECK OUTPUT SIGNAL FOR ECM.</b> Measure the voltage between ECM and chassis ground. <b>Connector &amp; terminal</b> <b>(B135) No. 20 (+) — Chassis ground (-):</b>	Is the voltage 4.95 V or more?	Go to step 5. Replace the front oxygen (A/F) sensor. <Ref. to FU(H6DO)-48, Front Oxygen (A/F) Sensor.>
5	<b>CHECK OUTPUT SIGNAL FOR ECM.</b> Measure the voltage between ECM and chassis ground. <b>Connector &amp; terminal</b> <b>(B135) No. 8 (+) — Chassis ground (-):</b> <b>(B135) No. 20 (+) — Chassis ground (-):</b>	Is the voltage 8 V or more?	Repair the short circuit to power in the harness between ECM and front oxygen (A/F) sensor connector. After repair, replace the ECM. <Ref. to FU(H6DO)-51, Engine Control Module (ECM).> Repair the poor contact of ECM connector.

# Diagnostic Procedure with Diagnostic Trouble Code (DTC)

ENGINE (DIAGNOSTICS)

## FR:DTC P219A BANK 1 AIR-FUEL RATIO IMBALANCE

### DTC DETECTING CONDITION:

- Detected when two consecutive driving cycles with fault occur.
- GENERAL DESCRIPTION <Ref. to GD(H6DO)-235, DTC P219A BANK 1 AIR-FUEL RATIO IMBALANCE, Diagnostic Trouble Code (DTC) Detecting Criteria.>

### TROUBLE SYMPTOM:

- Engine stalls.
- Improper idling

### CAUTION:

After servicing or replacing faulty parts, perform Clear Memory Mode <Ref. to EN(H6DO)(diag)-62, OPERATION, Clear Memory Mode.>, and Inspection Mode <Ref. to EN(H6DO)(diag)-47, PROCEDURE, Inspection Mode.>.

### WIRING DIAGRAM:

Engine electrical system <Ref. to WI-32, Engine Electrical System.>

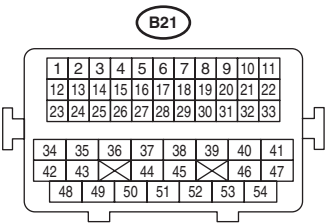
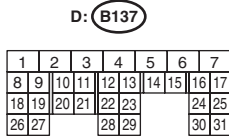
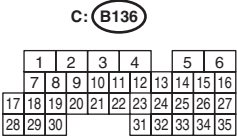
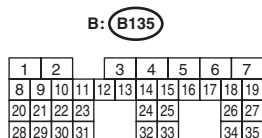
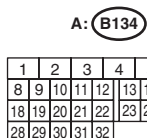
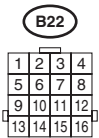
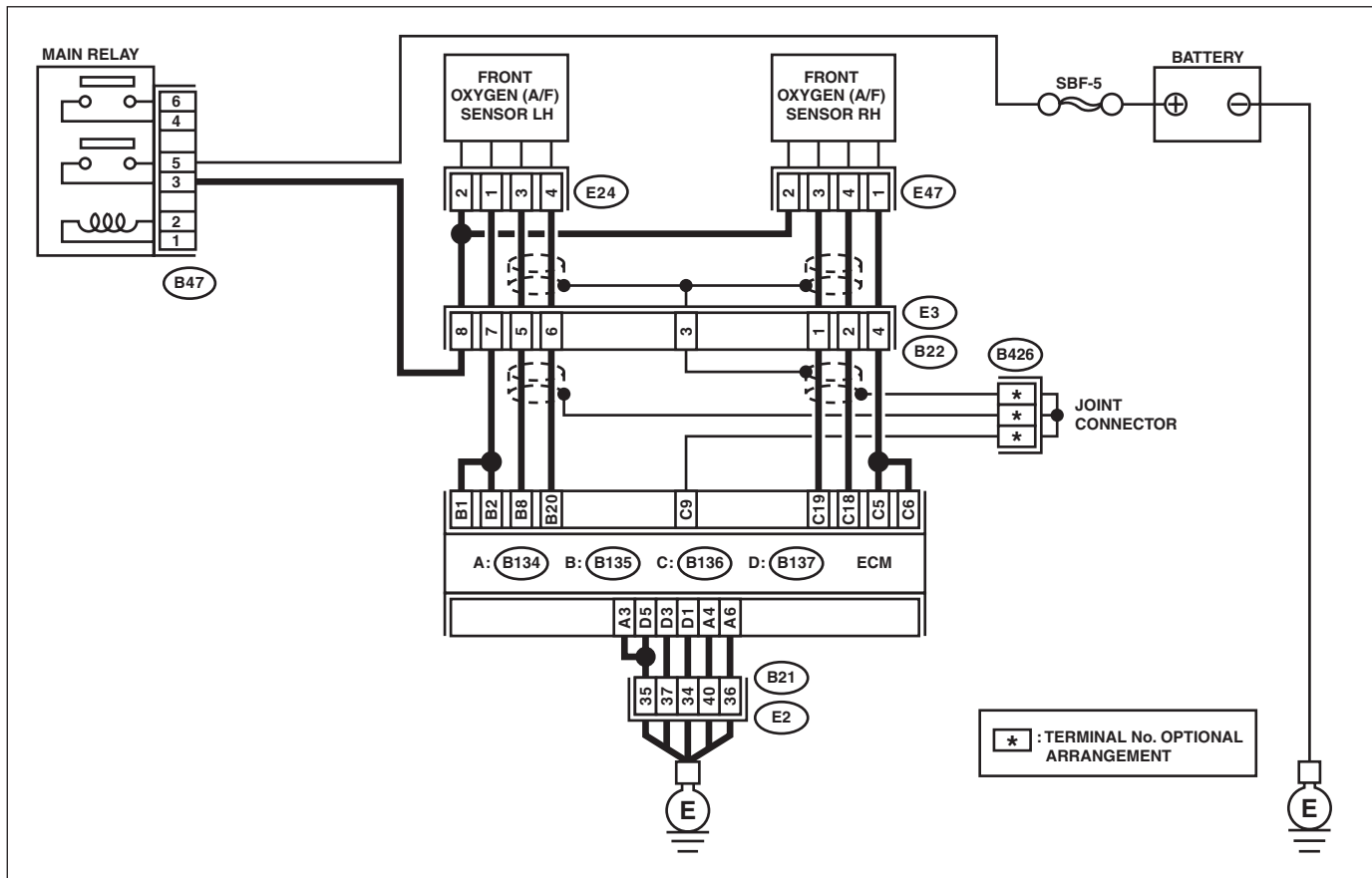

EN-08076

# Diagnostic Procedure with Diagnostic Trouble Code (DTC)

ENGINE (DIAGNOSTICS)

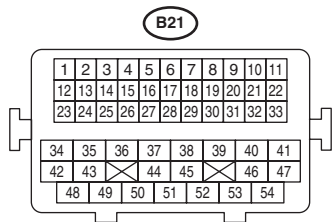
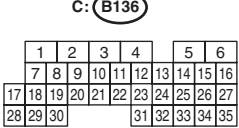
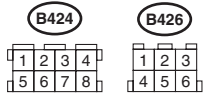
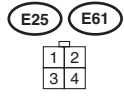
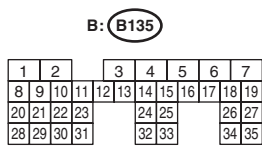
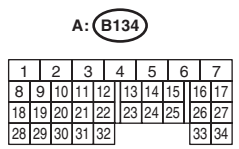
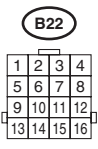
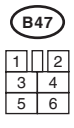
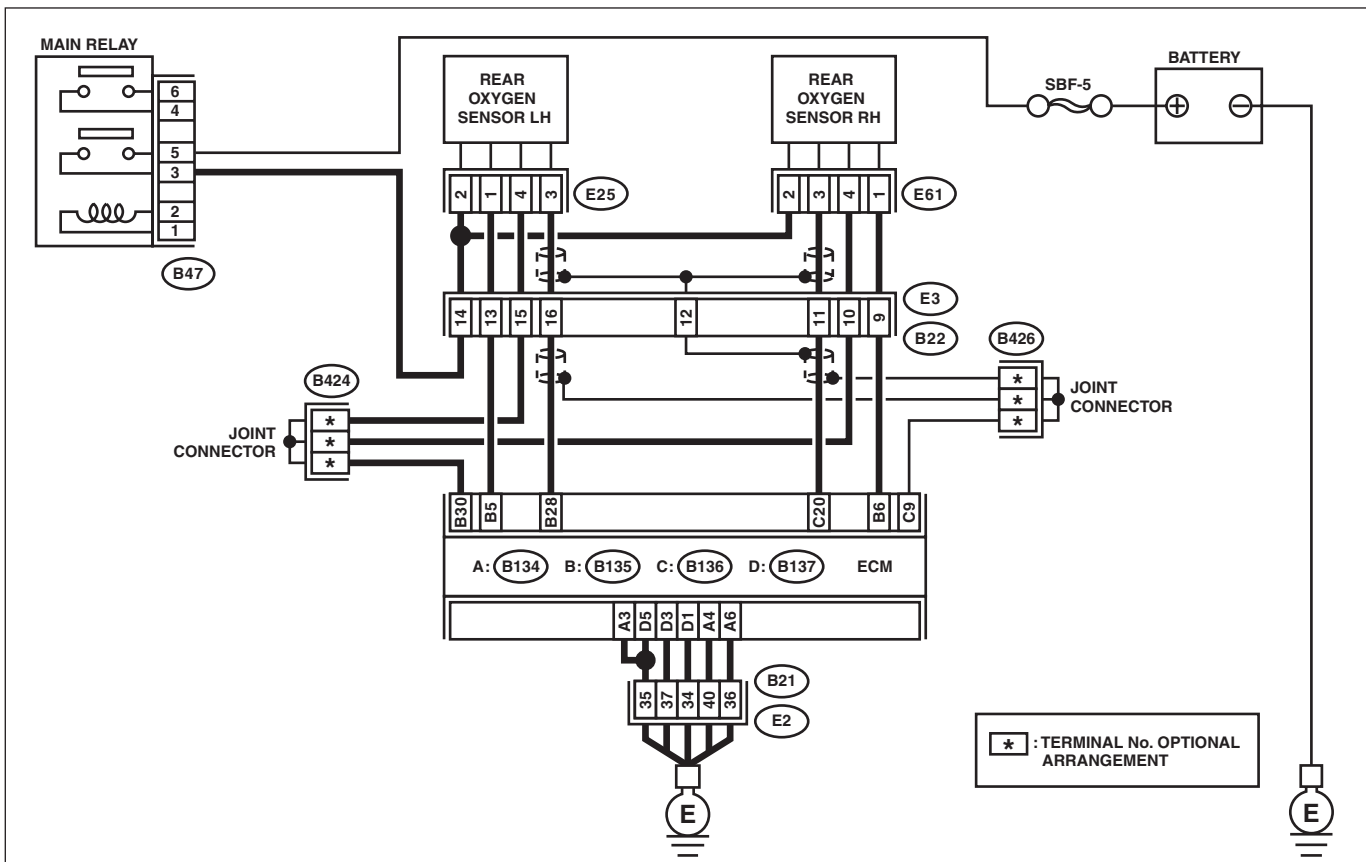

EN-08077

# Diagnostic Procedure with Diagnostic Trouble Code (DTC)

ENGINE (DIAGNOSTICS)

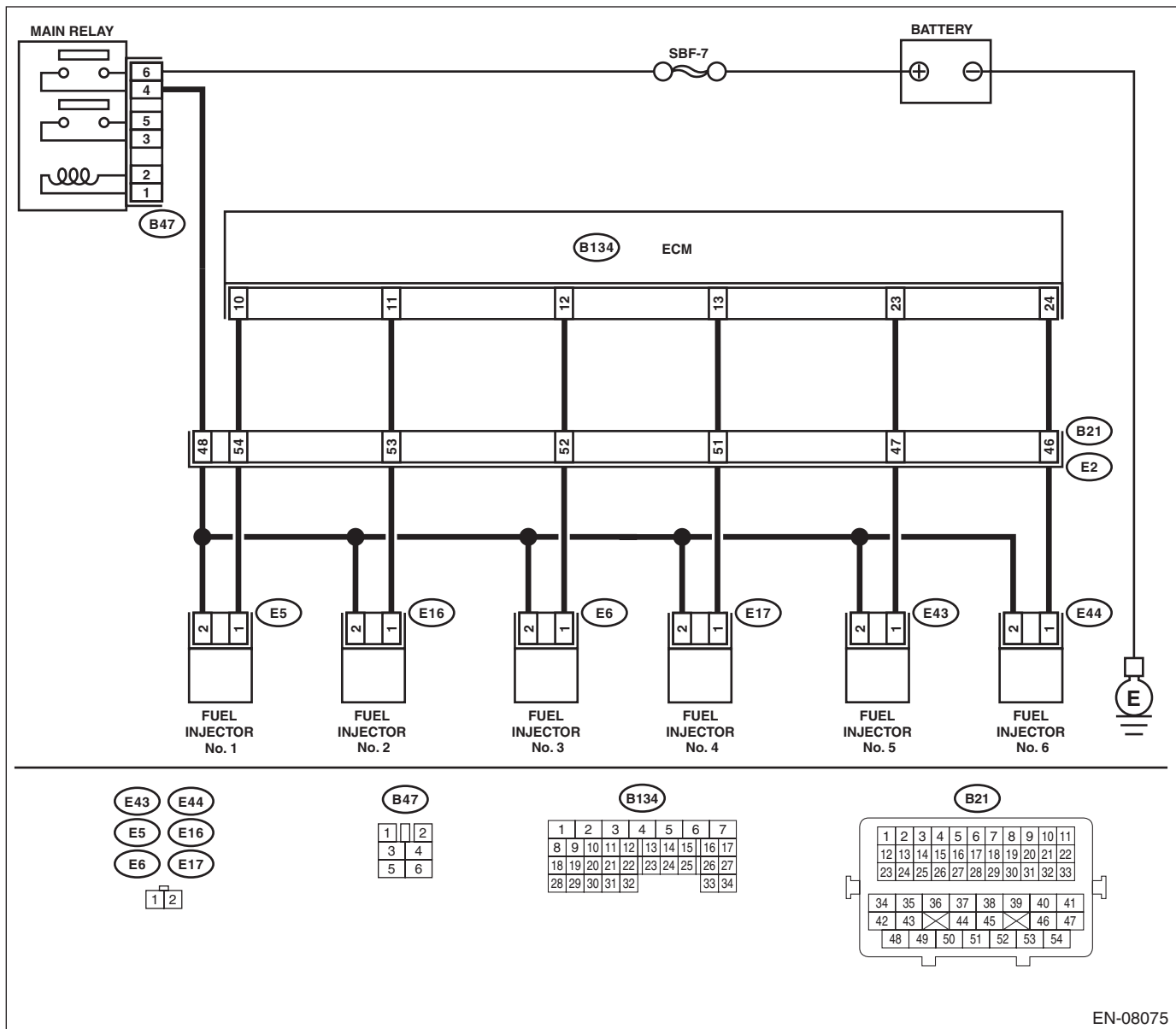

EN-08075

Step	Check	Yes	No
1	<b>CHECK FRONT OXYGEN (A/F) SENSOR CONNECTOR AND COUPLING CONNECTOR.</b>	Has water entered the connector?	Completely remove any water inside.
2	<b>CHECK HARNESS BETWEEN ECM AND FRONT OXYGEN (A/F) SENSOR CONNECTOR.</b> 1) Turn the ignition switch to OFF. 2) Disconnect the connectors from ECM and front oxygen (A/F) sensor. 3) Measure the resistance of harness between ECM and front oxygen (A/F) sensor connector. <b>Connector &amp; terminal</b> <b>(B136) No. 19 — (E47) No. 3:</b> <b>(B136) No. 18 — (E47) No. 4:</b>	Is the resistance less than 1 Ω?	Go to step 3.
			Go to step 2.
			Repair the harness and connector. <b>NOTE:</b> In this case, repair the following item: • Open circuit in harness between ECM and front oxygen (A/F) sensor connector • Poor contact of coupling connector

# Diagnostic Procedure with Diagnostic Trouble Code (DTC)

ENGINE (DIAGNOSTICS)

Step	Check	Yes	No
<b>3 CHECK HARNESS BETWEEN ECM AND FRONT OXYGEN (A/F) SENSOR CONNECTOR.</b> Measure the resistance between ECM and chassis ground. <i>Connector &amp; terminal</i> <i>(B136) No. 19 — Chassis ground:</i> <i>(B136) No. 18 — Chassis ground:</i>	Is the resistance 1 MΩ or more?	Go to step 4.	Repair the ground short circuit of harness between ECM and front oxygen (A/F) sensor connector.
<b>4 CHECK OUTPUT SIGNAL FOR ECM.</b> 1) Connect the connector to ECM. 2) Turn the ignition switch to ON. 3) Measure the voltage between front oxygen (A/F) sensor connector and chassis ground. <i>Connector &amp; terminal</i> <i>(E47) No. 3 (+) — Chassis ground (-):</i>	Is the voltage 4.5 V or more?	Go to step 6.	Go to step 5.
<b>5 CHECK OUTPUT SIGNAL FOR ECM.</b> Measure the voltage between front oxygen (A/F) sensor connector and chassis ground. <i>Connector &amp; terminal</i> <i>(E47) No. 4 (+) — Chassis ground (-):</i>	Is the voltage 4.95 V or more?	Go to step 6.	Go to step 7.
<b>6 CHECK OUTPUT SIGNAL FOR ECM.</b> Measure the voltage between front oxygen (A/F) sensor connector and chassis ground. <i>Connector &amp; terminal</i> <i>(E47) No. 3 (+) — Chassis ground (-):</i> <i>(E47) No. 4 (+) — Chassis ground (-):</i>	Is the voltage 8 V or more?	Repair the short circuit to power in the harness between ECM and front oxygen (A/F) sensor connector. After repair, replace the ECM. <Ref. to FU(H6DO)-51, Engine Control Module (ECM).>	Repair the poor contact of ECM connector.
<b>7 CHECK EXHAUST SYSTEM.</b>	Are there holes or loose bolts on exhaust system?	Repair the exhaust system.	Go to step 8.
<b>8 CHECK AIR INTAKE SYSTEM.</b>	Are there holes, loose bolts or disconnection of hose on air intake system?	Repair the air intake system.	Go to step 9.
<b>9 CHECK FUEL PRESSURE.</b> <b>WARNING:</b> Place “NO OPEN FLAMES” signs near the working area. <b>CAUTION:</b> Be careful not to spill fuel. 1) Connect the front oxygen (A/F) sensor connector. 2) Measure the fuel pressure. <Ref. to ME(H6DO)-31, INSPECTION, Fuel Pressure.> <b>CAUTION:</b> Release fuel pressure before removing the fuel pressure gauge.	Is the measured value 340 — 400 kPa (3.5 — 4.1 kgf/cm <sup>2</sup> , 49 — 58 psi)?	Go to step 10.	Repair the following item. Fuel pressure is too high: • Clogged fuel line or bent hose Fuel pressure is too low: • Improper fuel pump discharge • Clogged fuel line

# Diagnostic Procedure with Diagnostic Trouble Code (DTC)

## ENGINE (DIAGNOSTICS)

Step	Check	Yes	No
<p><b>10 CHECK ENGINE COOLANT TEMPERATURE SENSOR.</b></p> <p>1) Start the engine and warm up completely.</p> <p>2) Read the value of «Coolant Temp.» using the Subaru Select Monitor or a general scan tool.</p> <p>NOTE:</p> <ul style="list-style-type: none"> <li>• Subaru Select Monitor</li> </ul> <p>For detailed operation procedures, refer to “READ CURRENT DATA FOR ENGINE”. &lt;Ref. to EN(H6DO)(diag)-37, Subaru Select Monitor.&gt;</p> <ul style="list-style-type: none"> <li>• General scan tool</li> </ul> <p>For detailed operation procedures, refer to the general scan tool operation manual.</p>	<p>Is the value of «Coolant Temp.» 75°C (167°F) or more?</p>	<p>Go to step 11.</p>	<p>Replace the engine coolant temperature sensor. &lt;Ref. to FU(H6DO)-30, Engine Coolant Temperature Sensor.&gt;</p>
<p><b>11 CHECK MASS AIR FLOW AND INTAKE AIR TEMPERATURE SENSOR.</b></p> <p>1) Start the engine and warm up engine until coolant temperature is higher than 75°C (167°F).</p> <p>2) Place the select lever in “P” range or “N” range.</p> <p>3) Turn the A/C switch to OFF.</p> <p>4) Turn all the accessory switches to OFF.</p> <p>5) Read the value of «Mass Air Flow» using the Subaru Select Monitor or a general scan tool.</p> <p>NOTE:</p> <ul style="list-style-type: none"> <li>• Subaru Select Monitor</li> </ul> <p>For detailed operation procedures, refer to “READ CURRENT DATA FOR ENGINE”. &lt;Ref. to EN(H6DO)(diag)-37, Subaru Select Monitor.&gt;</p> <ul style="list-style-type: none"> <li>• General scan tool</li> </ul> <p>For detailed operation procedures, refer to the general scan tool operation manual.</p>	<p>Is the value of «Mass Air Flow» 2.0 — 5.0 g/s (0.26 — 0.66 lb/m)?</p>	<p>Go to step 12.</p>	<p>Replace the mass air flow and intake air temperature sensor. &lt;Ref. to FU(H6DO)-40, Mass Air Flow and Intake Air Temperature Sensor.&gt;</p>
<p><b>12 CHECK MASS AIR FLOW AND INTAKE AIR TEMPERATURE SENSOR.</b></p> <p>1) Start the engine and warm up engine until coolant temperature is higher than 75°C (167°F).</p> <p>2) Place the select lever in “P” range or “N” range.</p> <p>3) Turn the A/C switch to OFF.</p> <p>4) Turn all the accessory switches to OFF.</p> <p>5) Open the front hood.</p> <p>6) Measure the ambient temperature.</p> <p>7) Read the value of «Intake Air Temp.» using the Subaru Select Monitor or a general scan tool.</p> <p>NOTE:</p> <ul style="list-style-type: none"> <li>• Subaru Select Monitor</li> </ul> <p>For detailed operation procedures, refer to “READ CURRENT DATA FOR ENGINE”. &lt;Ref. to EN(H6DO)(diag)-37, Subaru Select Monitor.&gt;</p> <ul style="list-style-type: none"> <li>• General scan tool</li> </ul> <p>For detailed operation procedures, refer to the general scan tool operation manual.</p>	<p>Subtract ambient temperature from «Intake Air Temp.». Is the obtained value -10 — 50°C (-18 — 90°F)?</p>	<p>Go to step 13.</p>	<p>Check the mass air flow and intake air temperature sensor. &lt;Ref. to FU(H6DO)-40, Mass Air Flow and Intake Air Temperature Sensor.&gt;</p>



# Diagnostic Procedure with Diagnostic Trouble Code (DTC)

ENGINE (DIAGNOSTICS)

Step	Check	Yes	No
<p><b>13 CHECK REAR OXYGEN SENSOR DATA.</b>                      1) Warm up the engine until engine coolant temperature is higher than 75°C (167°F), and keep the engine speed at 3,000 rpm. (2 minutes maximum)                      2) Read the value of «Front O2 Sensor #1» using the Subaru Select Monitor or a general scan tool.                      NOTE:                      • Subaru Select Monitor                      For detailed operation procedures, refer to “READ CURRENT DATA FOR ENGINE”. &lt;Ref. to EN(H6DO)(diag)-37, Subaru Select Monitor.&gt;                      • General scan tool                      For detailed operation procedures, refer to the general scan tool operation manual.</p>	<p>Is the value of «Front O2 Sensor #1» 0.490 V or more?</p>	<p>Go to step 14.</p>	<p>Go to step 15.</p>
<p><b>14 CHECK REAR OXYGEN SENSOR DATA.</b>                      1) Warm up the engine until engine coolant temperature is higher than 75°C (167°F), and rapidly reduce the engine speed from 3,000 rpm.                      2) Read the value of «Front O2 Sensor #1» using the Subaru Select Monitor or a general scan tool.                      NOTE:                      • Subaru Select Monitor                      For detailed operation procedures, refer to “READ CURRENT DATA FOR ENGINE”. &lt;Ref. to EN(H6DO)(diag)-37, Subaru Select Monitor.&gt;                      • General scan tool                      For detailed operation procedures, refer to the general scan tool operation manual.</p>	<p>Is the value of «Front O2 Sensor #1» 0.250 V or less?</p>	<p>Go to step 16.</p>	<p>Go to step 15.</p>
<p><b>15 CHECK REAR OXYGEN SENSOR CONNECTOR AND COUPLING CONNECTOR.</b></p>	<p>Has water entered the connector?</p>	<p>Completely remove any water inside.</p>	<p>Go to step 17.</p>
<p><b>16 CHECK FRONT OXYGEN (A/F) SENSOR USING REAR OXYGEN SENSOR SIGNAL.</b>                      1) Warm up the engine until engine coolant temperature is higher than 75°C (167°F), then keep the engine idling for 5 minutes or more.                      2) Read the value of «Front O2 Sensor #1» using the Subaru Select Monitor or a general scan tool.                      NOTE:                      • Subaru Select Monitor                      For detailed operation procedures, refer to “READ CURRENT DATA FOR ENGINE”. &lt;Ref. to EN(H6DO)(diag)-37, Subaru Select Monitor.&gt;                      • General scan tool                      For detailed operation procedures, refer to the general scan tool operation manual.</p>	<p>Is the value in «Front O2 Sensor #1» kept at 0.250 V or less for 5 minutes or more?</p>	<p>Replace the front oxygen (A/F) sensor. &lt;Ref. to FU(H6DO)-48, Front Oxygen (A/F) Sensor.&gt;</p>	<p>Go to step 17.</p>

# Diagnostic Procedure with Diagnostic Trouble Code (DTC)

## ENGINE (DIAGNOSTICS)

Step	Check	Yes	No
<b>17 CHECK HARNESS BETWEEN ECM AND REAR OXYGEN SENSOR CONNECTOR.</b> 1) Turn the ignition switch to OFF. 2) Disconnect the connector from ECM and rear oxygen sensor. 3) Measure the resistance of harness between ECM and rear oxygen sensor connector. <b>Connector &amp; terminal</b> <b>(B136) No. 20 — (E61) No. 3:</b> <b>(B135) No. 30 — (E61) No. 4:</b>	Is the resistance less than 1 $\Omega$ ?	Go to step 18.	Repair the harness and connector. NOTE: In this case, repair the following item: <ul style="list-style-type: none"> <li>• Open circuit in harness between ECM and rear oxygen sensor connector</li> <li>• Poor contact of coupling connector</li> </ul>
<b>18 CHECK HARNESS BETWEEN ECM AND REAR OXYGEN SENSOR CONNECTOR.</b> 1) Connect the connector to ECM. 2) Turn the ignition switch to ON. 3) Measure the voltage between rear oxygen sensor connector and chassis ground. <b>Connector &amp; terminal</b> <b>(E61) No. 3 (+) — Chassis ground (-):</b>	Is the voltage 0.2 — 0.5 V?	Replace the rear oxygen sensor. <Ref. to FU(H6DO)-50, Rear Oxygen Sensor.>	Go to step 19.
<b>19 CHECK OUTPUT SIGNAL OF ECM.</b> 1) Turn the ignition switch to ON. 2) Measure the voltage between ECM and chassis ground on faulty cylinders. <b>Connector &amp; terminal</b> <b>#1 (B134) No. 10 (+) — Chassis ground (-):</b> <b>#2 (B134) No. 11 (+) — Chassis ground (-):</b> <b>#3 (B134) No. 12 (+) — Chassis ground (-):</b> <b>#4 (B134) No. 13 (+) — Chassis ground (-):</b> <b>#5 (B134) No. 23 (+) — Chassis ground (-):</b> <b>#6 (B134) No. 24 (+) — Chassis ground (-):</b>	Is the voltage 10 V or more?	Go to step 24.	Go to step 20.
<b>20 CHECK HARNESS BETWEEN ECM AND FUEL INJECTOR.</b> 1) Turn the ignition switch to OFF. 2) Disconnect the connector from fuel injector on faulty cylinders. 3) Measure the resistance between fuel injector connector and engine ground on faulty cylinders. <b>Connector &amp; terminal</b> <b>#1 (E5) No. 1 — Engine ground:</b> <b>#2 (E16) No. 1 — Engine ground:</b> <b>#3 (E6) No. 1 — Engine ground:</b> <b>#4 (E17) No. 1 — Engine ground:</b> <b>#5 (E43) No. 1 — Engine ground:</b> <b>#6 (E44) No. 1 — Engine ground:</b>	Is the resistance 1 M $\Omega$ or more?	Go to step 21.	Repair the short circuit to ground in harness between ECM and fuel injector connector.
<b>21 CHECK HARNESS BETWEEN ECM AND FUEL INJECTOR.</b> Measure the resistance of harness between ECM and fuel injector connector on faulty cylinders. <b>Connector &amp; terminal</b> <b>#1 (B134) No. 10 — (E5) No. 1:</b> <b>#2 (B134) No. 11 — (E16) No. 1:</b> <b>#3 (B134) No. 12 — (E6) No. 1:</b> <b>#4 (B134) No. 13 — (E17) No. 1:</b> <b>#5 (B134) No. 23 — (E43) No. 1:</b> <b>#6 (B134) No. 24 — (E44) No. 1:</b>	Is the resistance less than 1 $\Omega$ ?	Go to step 22.	Repair the harness and connector. NOTE: In this case, repair the following item: <ul style="list-style-type: none"> <li>• Open circuit in harness between ECM and fuel injector connector</li> <li>• Poor contact of coupling connector</li> </ul>

# Diagnostic Procedure with Diagnostic Trouble Code (DTC)

ENGINE (DIAGNOSTICS)

Step	Check	Yes	No
<b>22 CHECK FUEL INJECTOR.</b> Measure the resistance between fuel injector terminals on faulty cylinder. <i>Terminals</i> <i>No. 1 — No. 2:</i>	Is the resistance 5 — 20 Ω?	Go to step 23.	Replace the faulty fuel injector. <Ref. to FU(H6DO)-42, Fuel Injector.>
<b>23 CHECK POWER SUPPLY LINE.</b> 1) Turn the ignition switch to ON. 2) Measure the voltage between fuel injector connector of faulty cylinders and engine ground. <i>Connector &amp; terminal</i> <i>#1 (E5) No. 2 (+) — Engine ground (-):</i> <i>#2 (E16) No. 2 (+) — Engine ground (-):</i> <i>#3 (E6) No. 2 (+) — Engine ground (-):</i> <i>#4 (E17) No. 2 (+) — Engine ground (-):</i> <i>#5 (E43) No. 2 (+) — Engine ground (-):</i> <i>#6 (E44) No. 2 (+) — Engine ground (-):</i>	Is the voltage 10 V or more?	Repair the poor contact of all connectors in fuel injector circuit.	Repair the harness and connector. NOTE: In this case, repair the following item: • Open circuit in harness between the main relay and fuel injector connector on faulty cylinders • Poor contact of coupling connector • Poor contact of main relay connector
<b>24 CHECK HARNESS BETWEEN ECM AND FUEL INJECTOR.</b> 1) Turn the ignition switch to OFF. 2) Disconnect the connector from fuel injector on faulty cylinders. 3) Turn the ignition switch to ON. 4) Measure the voltage between ECM and chassis ground on faulty cylinders. <i>Connector &amp; terminal</i> <i>#1 (B134) No. 10 (+) — Chassis ground (-):</i> <i>#2 (B134) No. 11 (+) — Chassis ground (-):</i> <i>#3 (B134) No. 12 (+) — Chassis ground (-):</i> <i>#4 (B134) No. 13 (+) — Chassis ground (-):</i> <i>#5 (B134) No. 23 (+) — Chassis ground (-):</i> <i>#6 (B134) No. 24 (+) — Chassis ground (-):</i>	Is the voltage 10 V or more?	Repair the short circuit to power in harness between ECM and fuel injector connector.	Go to step 25.
<b>25 CHECK FUEL INJECTOR.</b> 1) Turn the ignition switch to OFF. 2) Measure the resistance between fuel injector terminals on faulty cylinder. <i>Terminals</i> <i>No. 1 — No. 2:</i>	Is the resistance 5 — 20 Ω?	Go to step 26.	Replace the faulty fuel injector. <Ref. to FU(H6DO)-42, Fuel Injector.>
<b>26 CHECK INSTALLATION OF CAMSHAFT POSITION SENSOR/CRANKSHAFT POSITION SENSOR.</b>	Is the camshaft position sensor or crankshaft position sensor loosely installed?	Tighten the camshaft position sensor or crankshaft position sensor.	Go to step 27.
<b>27 CHECK CRANK PLATE.</b>	Is the crank sprocket rusted or the teeth of crank plate broken?	Replace the crank plate. <Ref. to ME(H6DO)-97, Cylinder Block.>	Go to step 28.
<b>28 CHECK INSTALLATION CONDITION OF TIMING CHAIN.</b> Turn the crankshaft using ST, and align the alignment mark on crank sprocket with alignment mark on cylinder block. ST 18252AA000 CRANKSHAFT SOCKET	Is the timing chain dislocated from its proper position?	Correct the installation condition of timing chain. <Ref. to ME(H6DO)-54, Timing Chain Assembly.>	Go to step 29.

# Diagnostic Procedure with Diagnostic Trouble Code (DTC)

## ENGINE (DIAGNOSTICS)

Step	Check	Yes	No
<b>29</b>	<b>CHECK FUEL LEVEL.</b>	Is the fuel meter indication lower than the "Lower" level?	Refill the fuel so that the fuel meter indication is higher than the "Lower" level, and proceed to the next step. Go to step <b>30</b> .
<b>30</b>	<b>CHECK STATUS OF MALFUNCTION INDICATOR LIGHT.</b> 1) Clear the memory using the Subaru Select Monitor or general scan tool. <Ref. to EN(H6DO)(diag)-62, Clear Memory Mode.> 2) Start the engine, and drive the vehicle 10 minutes or more.	Does the malfunction indicator light illuminate or blink?	Go to step <b>32</b> .  Go to step <b>31</b> .
<b>31</b>	<b>CHECK CAUSE OF MISFIRE.</b>	Was the cause of misfire identified when the engine is running?	Finish diagnostics operation, if the engine has no abnormality.  Repair the poor contact of connector. NOTE: In this case, repair the following item: • Poor contact of ignition coil connector • Poor contact of fuel injector connector on faulty cylinders • Poor contact of ECM connector • Poor contact of coupling connector
<b>32</b>	<b>CHECK AIR INTAKE SYSTEM.</b>	Is there any fault in air intake system?	Repair the air intake system. NOTE: Check the following items. • Are there air leaks or air suction caused by loose or dislocated nuts and bolts? • Are there cracks or any disconnection of hoses?
<b>33</b>	<b>CHECK MISFIRE SYMPTOM.</b> 1) Turn the ignition switch to ON. 2) Check for DTC. <Ref. to EN(H6DO)(diag)-46, Read Diagnostic Trouble Code (DTC).>	Does the Subaru Select Monitor or general scan tool indicate only one DTC?	Go to step <b>36</b> .  Go to step <b>34</b> .
<b>34</b>	<b>CHECK DTC ON DISPLAY.</b>	Is DTC P0301, P0303 and P0305 displayed?	Go to step <b>37</b> .  Go to step <b>35</b> .
<b>35</b>	<b>CHECK DTC ON DISPLAY.</b>	Is DTC P0302, P0304 and P0306 displayed?	Go to step <b>38</b> .  Go to step <b>39</b> .

# Diagnostic Procedure with Diagnostic Trouble Code (DTC)

ENGINE (DIAGNOSTICS)

Step	Check	Yes	No
36 <b>ONLY ONE CYLINDER.</b>	Is there any fault in the cylinder?	Repair or replace faulty parts. NOTE: Check the following items. • Spark plug • Ignition coil • Fuel injector • Compression ratio	Check DTC P0171, P0172, P0174 or P0175 using "List of Diagnostic Trouble Code (DTC)". <Ref. to EN(H6DO)(diag)-89, List of Diagnostic Trouble Code (DTC).>
37 <b>GROUP OF #1, #3 AND #5 CYLINDERS.</b>	Is there any fault in #1, #3 and #5 cylinders?	Repair or replace faulty parts. NOTE: Check the following items. • Spark plug • Ignition coil • Fuel injector • Compression ratio • Skipping timing chain teeth	Check DTC P0171, P0172, P0174 or P0175 using "List of Diagnostic Trouble Code (DTC)". <Ref. to EN(H6DO)(diag)-89, List of Diagnostic Trouble Code (DTC).>
38 <b>GROUP OF #2, #4 AND #6 CYLINDERS.</b>	Is there any fault in #2, #4 and #6 cylinders?	Repair or replace faulty parts. NOTE: Check the following items. • Spark plug • Ignition coil • Fuel injector • Compression ratio • Skipping timing chain teeth	Check DTC P0171, P0172, P0174 or P0175 using "List of Diagnostic Trouble Code (DTC)". <Ref. to EN(H6DO)(diag)-89, List of Diagnostic Trouble Code (DTC).>
39 <b>CYLINDER AT RANDOM.</b>	Is the engine idle rough?	Check DTC P0171, P0172, P0174 or P0175 using "List of Diagnostic Trouble Code (DTC)". <Ref. to EN(H6DO)(diag)-89, List of Diagnostic Trouble Code (DTC).>	Repair or replace faulty parts. NOTE: Check the following items. • Spark plug • Ignition coil • Fuel injector • Compression ratio

# Diagnostic Procedure with Diagnostic Trouble Code (DTC)

ENGINE (DIAGNOSTICS)

## FS:DTC P219B BANK 2 AIR-FUEL RATIO IMBALANCE

### DTC DETECTING CONDITION:

- Detected when two consecutive driving cycles with fault occur.
- GENERAL DESCRIPTION <Ref. to GD(H6DO)-237, DTC P219B BANK 2 AIR-FUEL RATIO IMBALANCE, Diagnostic Trouble Code (DTC) Detecting Criteria.>

### TROUBLE SYMPTOM:

- Engine stalls.
- Improper idling

### CAUTION:

After servicing or replacing faulty parts, perform Clear Memory Mode <Ref. to EN(H6DO)(diag)-62, OPERATION, Clear Memory Mode.>, and Inspection Mode <Ref. to EN(H6DO)(diag)-47, PROCEDURE, Inspection Mode.>.

### WIRING DIAGRAM:

Engine electrical system <Ref. to WI-32, Engine Electrical System.>

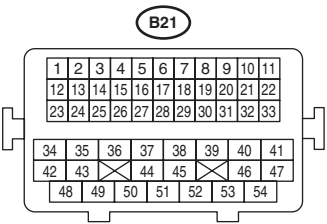
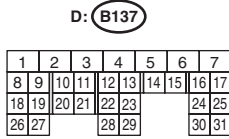
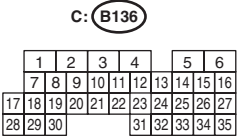
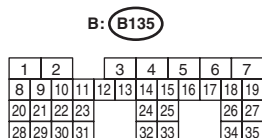
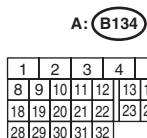
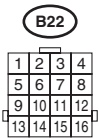
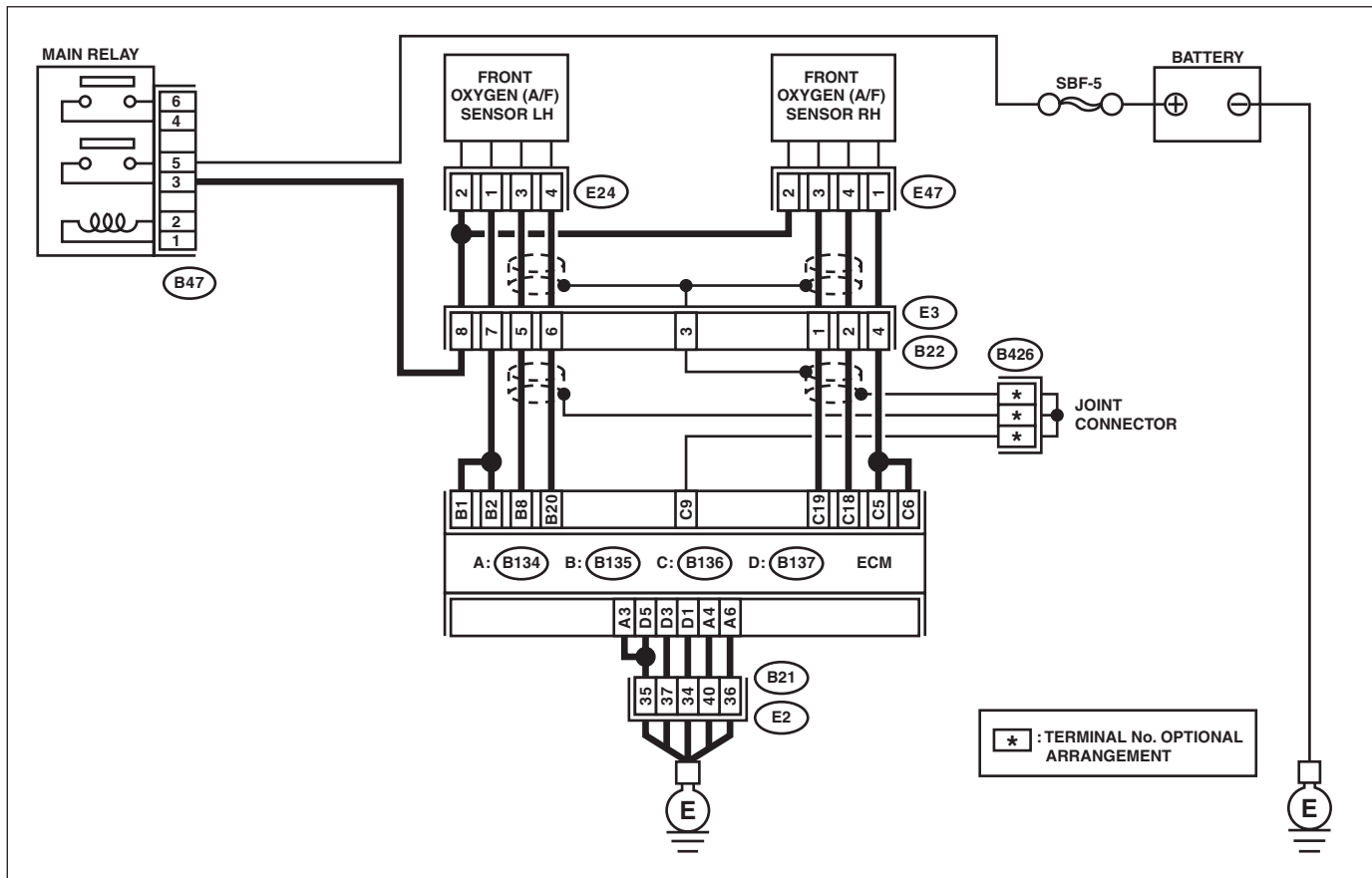

\* : TERMINAL No. OPTIONAL ARRANGEMENT

EN-08076

# Diagnostic Procedure with Diagnostic Trouble Code (DTC)

ENGINE (DIAGNOSTICS)

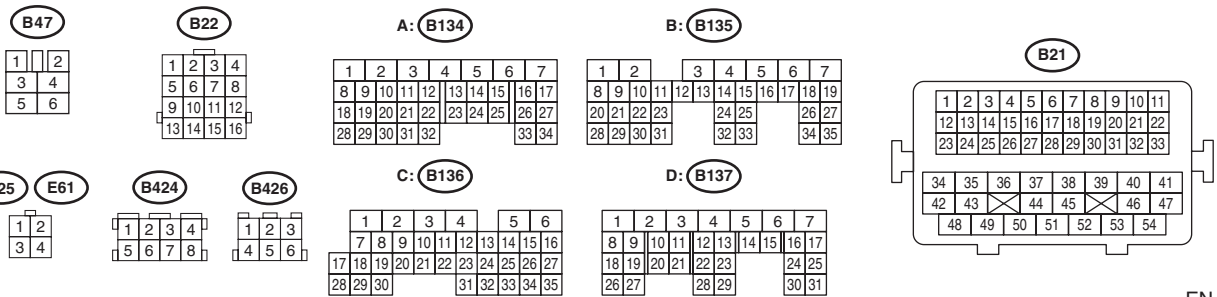
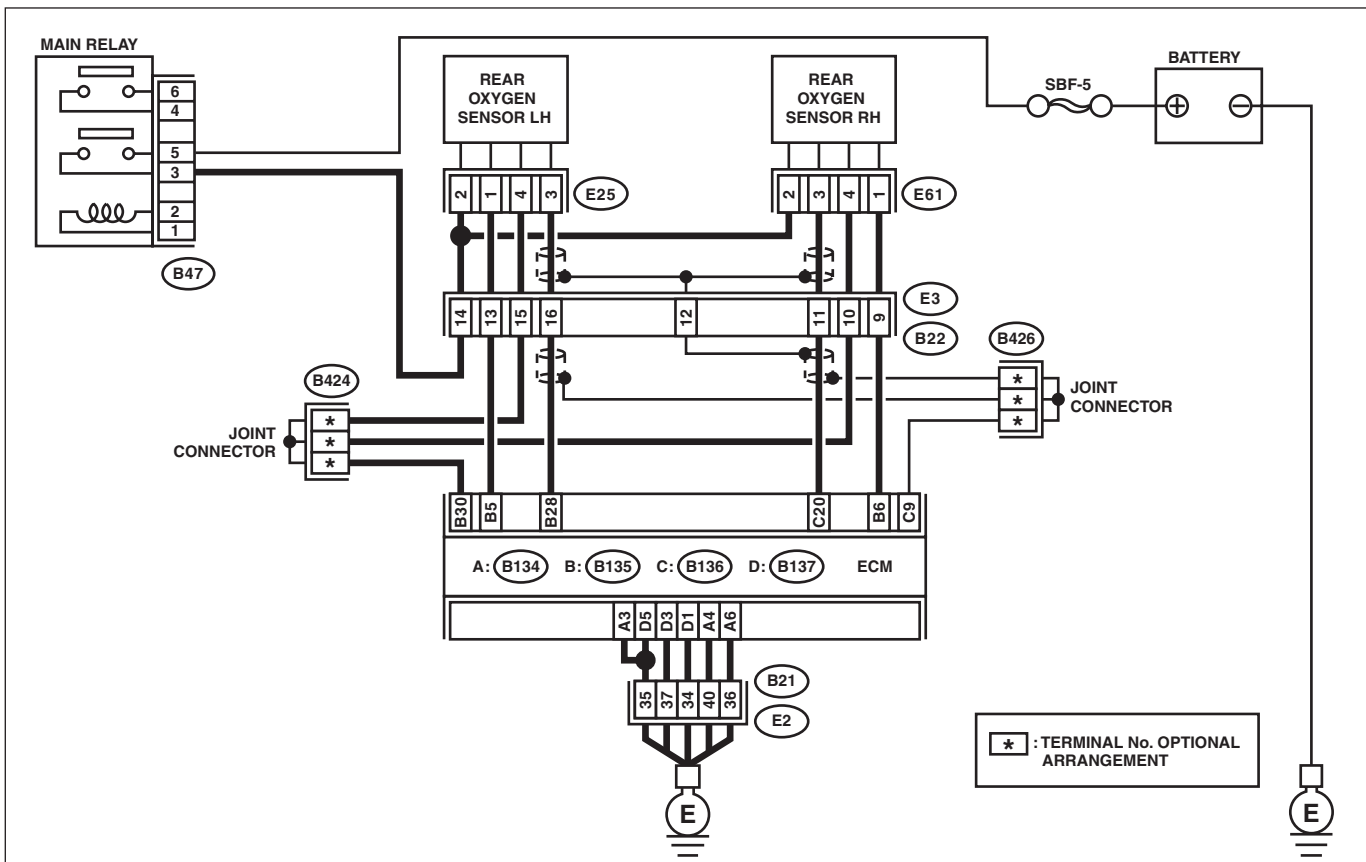

EN-08077

# Diagnostic Procedure with Diagnostic Trouble Code (DTC)

ENGINE (DIAGNOSTICS)

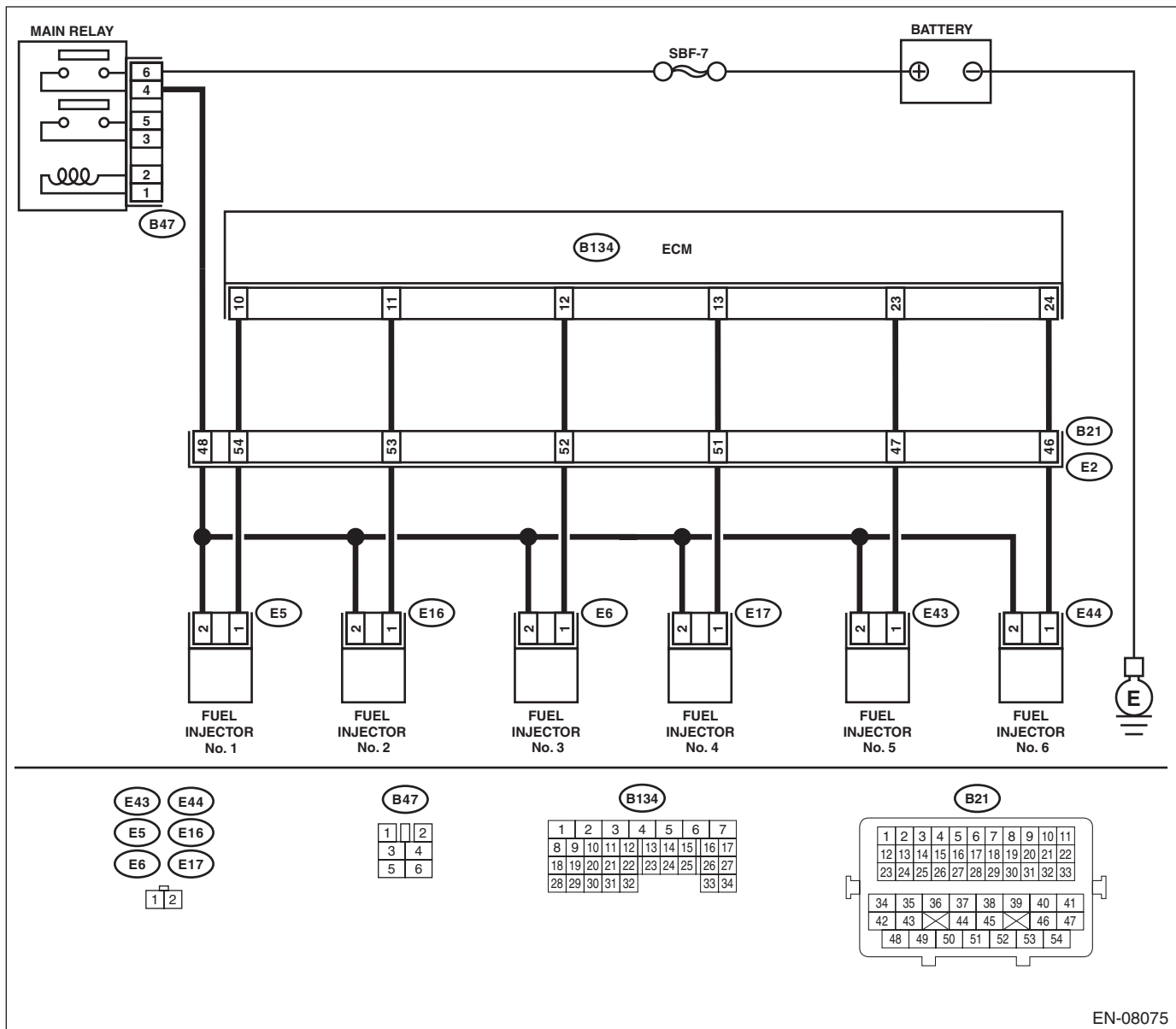

EN-08075

Step	Check	Yes	No
1	<b>CHECK FRONT OXYGEN (A/F) SENSOR CONNECTOR AND COUPLING CONNECTOR.</b>	Completely remove any water inside.	Go to step 2.
2	<b>CHECK HARNESS BETWEEN ECM AND FRONT OXYGEN (A/F) SENSOR CONNECTOR.</b> 1) Turn the ignition switch to OFF. 2) Disconnect the connectors from ECM and front oxygen (A/F) sensor. 3) Measure the resistance of harness between ECM and front oxygen (A/F) sensor connector. <b>Connector &amp; terminal</b> <b>(B135) No. 8 — (E24) No. 3:</b> <b>(B135) No. 20 — (E24) No. 4:</b>	Is the resistance less than 1 Ω? Go to step 3.	Repair the harness and connector. <b>NOTE:</b> In this case, repair the following item: • Open circuit in harness between ECM and front oxygen (A/F) sensor connector • Poor contact of coupling connector



# Diagnostic Procedure with Diagnostic Trouble Code (DTC)

ENGINE (DIAGNOSTICS)

Step	Check	Yes	No
<b>3 CHECK HARNESS BETWEEN ECM AND FRONT OXYGEN (A/F) SENSOR CONNECTOR.</b> Measure the resistance between ECM and chassis ground. <i><b>Connector &amp; terminal</b></i> <i><b>(B135) No. 8 — Chassis ground:</b></i> <i><b>(B135) No. 20 — Chassis ground:</b></i>	Is the resistance 1 M $\Omega$ or more?	Go to step 4.	Repair the ground short circuit of harness between ECM and front oxygen (A/F) sensor connector.
<b>4 CHECK OUTPUT SIGNAL FOR ECM.</b> 1) Connect the connector to ECM. 2) Turn the ignition switch to ON. 3) Measure the voltage between front oxygen (A/F) sensor connector and chassis ground. <i><b>Connector &amp; terminal</b></i> <i><b>(E24) No. 3 (+) — Chassis ground (-):</b></i>	Is the voltage 4.5 V or more?	Go to step 6.	Go to step 5.
<b>5 CHECK OUTPUT SIGNAL FOR ECM.</b> Measure the voltage between front oxygen (A/F) sensor connector and chassis ground. <i><b>Connector &amp; terminal</b></i> <i><b>(E24) No. 4 (+) — Chassis ground (-):</b></i>	Is the voltage 4.95 V or more?	Go to step 6.	Go to step 7.
<b>6 CHECK OUTPUT SIGNAL FOR ECM.</b> Measure the voltage between front oxygen (A/F) sensor connector and chassis ground. <i><b>Connector &amp; terminal</b></i> <i><b>(E24) No. 3 (+) — Chassis ground (-):</b></i> <i><b>(E24) No. 4 (+) — Chassis ground (-):</b></i>	Is the voltage 8 V or more?	Repair the short circuit to power in the harness between ECM and front oxygen (A/F) sensor connector. After repair, replace the ECM. <Ref. to FU(H6DO)-51, Engine Control Module (ECM).>	Repair the poor contact of ECM connector.
<b>7 CHECK EXHAUST SYSTEM.</b>	Are there holes or loose bolts on exhaust system?	Repair the exhaust system.	Go to step 8.
<b>8 CHECK AIR INTAKE SYSTEM.</b>	Are there holes, loose bolts or disconnection of hose on air intake system?	Repair the air intake system.	Go to step 9.
<b>9 CHECK FUEL PRESSURE.</b> <b>WARNING:</b> Place “NO OPEN FLAMES” signs near the working area. <b>CAUTION:</b> Be careful not to spill fuel. 1) Connect the front oxygen (A/F) sensor connector. 2) Measure the fuel pressure. <Ref. to ME(H6DO)-31, INSPECTION, Fuel Pressure.> <b>CAUTION:</b> Release fuel pressure before removing the fuel pressure gauge.	Is the measured value 340 — 400 kPa (3.5 — 4.1 kgf/cm <sup>2</sup> , 49 — 58 psi)?	Go to step 10.	Repair the following item. Fuel pressure is too high: • Clogged fuel line or bent hose Fuel pressure is too low: • Improper fuel pump discharge • Clogged fuel line

# Diagnostic Procedure with Diagnostic Trouble Code (DTC)

## ENGINE (DIAGNOSTICS)

Step	Check	Yes	No
<p><b>10 CHECK ENGINE COOLANT TEMPERATURE SENSOR.</b></p> <p>1) Start the engine and warm up completely.</p> <p>2) Read the value of «Coolant Temp.» using the Subaru Select Monitor or a general scan tool.</p> <p>NOTE:</p> <ul style="list-style-type: none"> <li>• Subaru Select Monitor</li> </ul> <p>For detailed operation procedures, refer to “READ CURRENT DATA FOR ENGINE”. &lt;Ref. to EN(H6DO)(diag)-37, Subaru Select Monitor.&gt;</p> <ul style="list-style-type: none"> <li>• General scan tool</li> </ul> <p>For detailed operation procedures, refer to the general scan tool operation manual.</p>	<p>Is the value of «Coolant Temp.» 75°C (167°F) or more?</p>	<p>Go to step 11.</p>	<p>Replace the engine coolant temperature sensor. &lt;Ref. to FU(H6DO)-30, Engine Coolant Temperature Sensor.&gt;</p>
<p><b>11 CHECK MASS AIR FLOW AND INTAKE AIR TEMPERATURE SENSOR.</b></p> <p>1) Start the engine and warm up engine until coolant temperature is higher than 75°C (167°F).</p> <p>2) Place the select lever in “P” range or “N” range.</p> <p>3) Turn the A/C switch to OFF.</p> <p>4) Turn all the accessory switches to OFF.</p> <p>5) Read the value of «Mass Air Flow» using the Subaru Select Monitor or a general scan tool.</p> <p>NOTE:</p> <ul style="list-style-type: none"> <li>• Subaru Select Monitor</li> </ul> <p>For detailed operation procedures, refer to “READ CURRENT DATA FOR ENGINE”. &lt;Ref. to EN(H6DO)(diag)-37, Subaru Select Monitor.&gt;</p> <ul style="list-style-type: none"> <li>• General scan tool</li> </ul> <p>For detailed operation procedures, refer to the general scan tool operation manual.</p>	<p>Is the value of «Mass Air Flow» 2.0 — 5.0 g/s (0.26 — 0.66 lb/m)?</p>	<p>Go to step 12.</p>	<p>Replace the mass air flow and intake air temperature sensor. &lt;Ref. to FU(H6DO)-40, Mass Air Flow and Intake Air Temperature Sensor.&gt;</p>
<p><b>12 CHECK MASS AIR FLOW AND INTAKE AIR TEMPERATURE SENSOR.</b></p> <p>1) Start the engine and warm up engine until coolant temperature is higher than 75°C (167°F).</p> <p>2) Place the select lever in “P” range or “N” range.</p> <p>3) Turn the A/C switch to OFF.</p> <p>4) Turn all the accessory switches to OFF.</p> <p>5) Open the front hood.</p> <p>6) Measure the ambient temperature.</p> <p>7) Read the value of «Intake Air Temp.» using the Subaru Select Monitor or a general scan tool.</p> <p>NOTE:</p> <ul style="list-style-type: none"> <li>• Subaru Select Monitor</li> </ul> <p>For detailed operation procedures, refer to “READ CURRENT DATA FOR ENGINE”. &lt;Ref. to EN(H6DO)(diag)-37, Subaru Select Monitor.&gt;</p> <ul style="list-style-type: none"> <li>• General scan tool</li> </ul> <p>For detailed operation procedures, refer to the general scan tool operation manual.</p>	<p>Subtract ambient temperature from «Intake Air Temp.». Is the obtained value -10 — 50°C (-18 — 90°F)?</p>	<p>Go to step 13.</p>	<p>Check the mass air flow and intake air temperature sensor. &lt;Ref. to FU(H6DO)-40, Mass Air Flow and Intake Air Temperature Sensor.&gt;</p>

# Diagnostic Procedure with Diagnostic Trouble Code (DTC)

ENGINE (DIAGNOSTICS)

Step	Check	Yes	No
<p><b>13 CHECK REAR OXYGEN SENSOR DATA.</b></p> <p>1) Warm up the engine until engine coolant temperature is higher than 75°C (167°F), and keep the engine speed at 3,000 rpm. (2 minutes maximum)</p> <p>2) Read the value of «Front O2 Sensor #2» using the Subaru Select Monitor or a general scan tool.</p> <p>NOTE:</p> <ul style="list-style-type: none"> <li>• Subaru Select Monitor</li> </ul> <p>For detailed operation procedures, refer to “READ CURRENT DATA FOR ENGINE”. &lt;Ref. to EN(H6DO)(diag)-37, Subaru Select Monitor.&gt;</p> <ul style="list-style-type: none"> <li>• General scan tool</li> </ul> <p>For detailed operation procedures, refer to the general scan tool operation manual.</p>	<p>Is the value of «Front O2 Sensor #2» 0.490 V or more?</p>	<p>Go to step 14.</p>	<p>Go to step 15.</p>
<p><b>14 CHECK REAR OXYGEN SENSOR DATA.</b></p> <p>1) Warm up the engine until engine coolant temperature is higher than 75°C (167°F), and rapidly reduce the engine speed from 3,000 rpm.</p> <p>2) Read the value of «Front O2 Sensor #2» using the Subaru Select Monitor or a general scan tool.</p> <p>NOTE:</p> <ul style="list-style-type: none"> <li>• Subaru Select Monitor</li> </ul> <p>For detailed operation procedures, refer to “READ CURRENT DATA FOR ENGINE”. &lt;Ref. to EN(H6DO)(diag)-37, Subaru Select Monitor.&gt;</p> <ul style="list-style-type: none"> <li>• General scan tool</li> </ul> <p>For detailed operation procedures, refer to the general scan tool operation manual.</p>	<p>Is the value of «Front O2 Sensor #2» 0.250 V or less?</p>	<p>Go to step 16.</p>	<p>Go to step 15.</p>
<p><b>15 CHECK REAR OXYGEN SENSOR CONNECTOR AND COUPLING CONNECTOR.</b></p>	<p>Has water entered the connector?</p>	<p>Completely remove any water inside.</p>	<p>Go to step 17.</p>
<p><b>16 CHECK FRONT OXYGEN (A/F) SENSOR USING REAR OXYGEN SENSOR SIGNAL.</b></p> <p>1) Warm up the engine until engine coolant temperature is higher than 75°C (167°F), then keep the engine idling for 5 minutes or more.</p> <p>2) Read the value of «Front O2 Sensor #2» using the Subaru Select Monitor or a general scan tool.</p> <p>NOTE:</p> <ul style="list-style-type: none"> <li>• Subaru Select Monitor</li> </ul> <p>For detailed operation procedures, refer to “READ CURRENT DATA FOR ENGINE”. &lt;Ref. to EN(H6DO)(diag)-37, Subaru Select Monitor.&gt;</p> <ul style="list-style-type: none"> <li>• General scan tool</li> </ul> <p>For detailed operation procedures, refer to the general scan tool operation manual.</p>	<p>Is the value in «Front O2 Sensor #2» kept at 0.250 V or less for 5 minutes or more?</p>	<p>Replace the front oxygen (A/F) sensor. &lt;Ref. to FU(H6DO)-48, Front Oxygen (A/F) Sensor.&gt;</p>	<p>Go to step 17.</p>

# Diagnostic Procedure with Diagnostic Trouble Code (DTC)

## ENGINE (DIAGNOSTICS)

Step	Check	Yes	No
<b>17 CHECK HARNESS BETWEEN ECM AND REAR OXYGEN SENSOR CONNECTOR.</b> 1) Turn the ignition switch to OFF. 2) Disconnect the connector from ECM and rear oxygen sensor. 3) Measure the resistance of harness between ECM and rear oxygen sensor connector. <b>Connector &amp; terminal</b> <b>(B135) No. 28 — (E25) No. 3:</b> <b>(B135) No. 30 — (E25) No. 4:</b>	Is the resistance less than 1 $\Omega$ ?	Go to step 18.	Repair the harness and connector. NOTE: In this case, repair the following item: <ul style="list-style-type: none"> <li>• Open circuit in harness between ECM and rear oxygen sensor connector</li> <li>• Poor contact of coupling connector</li> </ul>
<b>18 CHECK HARNESS BETWEEN ECM AND REAR OXYGEN SENSOR CONNECTOR.</b> 1) Connect the connector to ECM. 2) Turn the ignition switch to ON. 3) Measure the voltage between rear oxygen sensor connector and chassis ground. <b>Connector &amp; terminal</b> <b>(E25) No. 3 (+) — Chassis ground (-):</b>	Is the voltage 0.2 — 0.5 V?	Replace the rear oxygen sensor. <Ref. to FU(H6DO)-50, Rear Oxygen Sensor.>	Go to step 19.
<b>19 CHECK OUTPUT SIGNAL OF ECM.</b> 1) Turn the ignition switch to ON. 2) Measure the voltage between ECM and chassis ground on faulty cylinders. <b>Connector &amp; terminal</b> <b>#1 (B134) No. 10 (+) — Chassis ground (-):</b> <b>#2 (B134) No. 11 (+) — Chassis ground (-):</b> <b>#3 (B134) No. 12 (+) — Chassis ground (-):</b> <b>#4 (B134) No. 13 (+) — Chassis ground (-):</b> <b>#5 (B134) No. 23 (+) — Chassis ground (-):</b> <b>#6 (B134) No. 24 (+) — Chassis ground (-):</b>	Is the voltage 10 V or more?	Go to step 24.	Go to step 20.
<b>20 CHECK HARNESS BETWEEN ECM AND FUEL INJECTOR.</b> 1) Turn the ignition switch to OFF. 2) Disconnect the connector from fuel injector on faulty cylinders. 3) Measure the resistance between fuel injector connector and engine ground on faulty cylinders. <b>Connector &amp; terminal</b> <b>#1 (E5) No. 1 — Engine ground:</b> <b>#2 (E16) No. 1 — Engine ground:</b> <b>#3 (E6) No. 1 — Engine ground:</b> <b>#4 (E17) No. 1 — Engine ground:</b> <b>#5 (E43) No. 1 — Engine ground:</b> <b>#6 (E44) No. 1 — Engine ground:</b>	Is the resistance 1 M $\Omega$ or more?	Go to step 21.	Repair the short circuit to ground in harness between ECM and fuel injector connector.
<b>21 CHECK HARNESS BETWEEN ECM AND FUEL INJECTOR.</b> Measure the resistance of harness between ECM and fuel injector connector on faulty cylinders. <b>Connector &amp; terminal</b> <b>#1 (B134) No. 10 — (E5) No. 1:</b> <b>#2 (B134) No. 11 — (E16) No. 1:</b> <b>#3 (B134) No. 12 — (E6) No. 1:</b> <b>#4 (B134) No. 13 — (E17) No. 1:</b> <b>#5 (B134) No. 23 — (E43) No. 1:</b> <b>#6 (B134) No. 24 — (E44) No. 1:</b>	Is the resistance less than 1 $\Omega$ ?	Go to step 22.	Repair the harness and connector. NOTE: In this case, repair the following item: <ul style="list-style-type: none"> <li>• Open circuit in harness between ECM and fuel injector connector</li> <li>• Poor contact of coupling connector</li> </ul>

# Diagnostic Procedure with Diagnostic Trouble Code (DTC)

ENGINE (DIAGNOSTICS)

Step	Check	Yes	No
<b>22 CHECK FUEL INJECTOR.</b> Measure the resistance between fuel injector terminals on faulty cylinder. <i>Terminals</i> <i>No. 1 — No. 2:</i>	Is the resistance 5 — 20 Ω?	Go to step 23.	Replace the faulty fuel injector. <Ref. to FU(H6DO)-42, Fuel Injector.>
<b>23 CHECK POWER SUPPLY LINE.</b> 1) Turn the ignition switch to ON. 2) Measure the voltage between fuel injector connector of faulty cylinders and engine ground. <i>Connector &amp; terminal</i> <i>#1 (E5) No. 2 (+) — Engine ground (-):</i> <i>#2 (E16) No. 2 (+) — Engine ground (-):</i> <i>#3 (E6) No. 2 (+) — Engine ground (-):</i> <i>#4 (E17) No. 2 (+) — Engine ground (-):</i> <i>#5 (E43) No. 2 (+) — Engine ground (-):</i> <i>#6 (E44) No. 2 (+) — Engine ground (-):</i>	Is the voltage 10 V or more?	Repair the poor contact of all connectors in fuel injector circuit.	Repair the harness and connector. NOTE: In this case, repair the following item: • Open circuit in harness between the main relay and fuel injector connector on faulty cylinders • Poor contact of coupling connector • Poor contact of main relay connector
<b>24 CHECK HARNESS BETWEEN ECM AND FUEL INJECTOR.</b> 1) Turn the ignition switch to OFF. 2) Disconnect the connector from fuel injector on faulty cylinders. 3) Turn the ignition switch to ON. 4) Measure the voltage between ECM and chassis ground on faulty cylinders. <i>Connector &amp; terminal</i> <i>#1 (B134) No. 10 (+) — Chassis ground (-):</i> <i>#2 (B134) No. 11 (+) — Chassis ground (-):</i> <i>#3 (B134) No. 12 (+) — Chassis ground (-):</i> <i>#4 (B134) No. 13 (+) — Chassis ground (-):</i> <i>#5 (B134) No. 23 (+) — Chassis ground (-):</i> <i>#6 (B134) No. 24 (+) — Chassis ground (-):</i>	Is the voltage 10 V or more?	Repair the short circuit to power in harness between ECM and fuel injector connector.	Go to step 25.
<b>25 CHECK FUEL INJECTOR.</b> 1) Turn the ignition switch to OFF. 2) Measure the resistance between fuel injector terminals on faulty cylinder. <i>Terminals</i> <i>No. 1 — No. 2:</i>	Is the resistance 5 — 20 Ω?	Go to step 26.	Replace the faulty fuel injector. <Ref. to FU(H6DO)-42, Fuel Injector.>
<b>26 CHECK INSTALLATION OF CAMSHAFT POSITION SENSOR/CRANKSHAFT POSITION SENSOR.</b>	Is the camshaft position sensor or crankshaft position sensor loosely installed?	Tighten the camshaft position sensor or crankshaft position sensor.	Go to step 27.
<b>27 CHECK CRANK PLATE.</b>	Is the crank sprocket rusted or the teeth of crank plate broken?	Replace the crank plate. <Ref. to ME(H6DO)-97, Cylinder Block.>	Go to step 28.
<b>28 CHECK INSTALLATION CONDITION OF TIMING CHAIN.</b> Turn the crankshaft using ST, and align the alignment mark on crank sprocket with alignment mark on cylinder block. ST 18252AA000 CRANKSHAFT SOCKET	Is the timing chain dislocated from its proper position?	Correct the installation condition of timing chain. <Ref. to ME(H6DO)-54, Timing Chain Assembly.>	Go to step 29.

## Diagnostic Procedure with Diagnostic Trouble Code (DTC)

### ENGINE (DIAGNOSTICS)

Step	Check	Yes	No	
<b>29</b>	<b>CHECK FUEL LEVEL.</b>	Is the fuel meter indication lower than the "Lower" level?	Refill the fuel so that the fuel meter indication is higher than the "Lower" level, and proceed to the next step. Go to step <b>30</b> .	Go to step <b>30</b> .
<b>30</b>	<b>CHECK STATUS OF MALFUNCTION INDICATOR LIGHT.</b> 1) Clear the memory using the Subaru Select Monitor or general scan tool. <Ref. to EN(H6DO)(diag)-62, Clear Memory Mode.> 2) Start the engine, and drive the vehicle 10 minutes or more.	Does the malfunction indicator light illuminate or blink?	Go to step <b>32</b> .	Go to step <b>31</b> .
<b>31</b>	<b>CHECK CAUSE OF MISFIRE.</b>	Was the cause of misfire identified when the engine is running?	Finish diagnostics operation, if the engine has no abnormality.	Repair the poor contact of connector. <b>NOTE:</b> In this case, repair the following item: • Poor contact of ignition coil connector • Poor contact of fuel injector connector on faulty cylinders • Poor contact of ECM connector • Poor contact of coupling connector
<b>32</b>	<b>CHECK AIR INTAKE SYSTEM.</b>	Is there any fault in air intake system?	Repair the air intake system. <b>NOTE:</b> Check the following items. • Are there air leaks or air suction caused by loose or dislocated nuts and bolts? • Are there cracks or any disconnection of hoses?	Go to step <b>33</b> .
<b>33</b>	<b>CHECK MISFIRE SYMPTOM.</b> 1) Turn the ignition switch to ON. 2) Check for DTC. <Ref. to EN(H6DO)(diag)-46, Read Diagnostic Trouble Code (DTC).>	Does the Subaru Select Monitor or general scan tool indicate only one DTC?	Go to step <b>36</b> .	Go to step <b>34</b> .
<b>34</b>	<b>CHECK DTC ON DISPLAY.</b>	Is DTC P0301, P0303 and P0305 displayed?	Go to step <b>37</b> .	Go to step <b>35</b> .
<b>35</b>	<b>CHECK DTC ON DISPLAY.</b>	Is DTC P0302, P0304 and P0306 displayed?	Go to step <b>38</b> .	Go to step <b>39</b> .

# Diagnostic Procedure with Diagnostic Trouble Code (DTC)

ENGINE (DIAGNOSTICS)

Step	Check	Yes	No
36 <b>ONLY ONE CYLINDER.</b>	Is there any fault in the cylinder?	Repair or replace faulty parts. NOTE: Check the following items. • Spark plug • Ignition coil • Fuel injector • Compression ratio	Check DTC P0171, P0172, P0174 or P0175 using "List of Diagnostic Trouble Code (DTC)". <Ref. to EN(H6DO)(diag)-89, List of Diagnostic Trouble Code (DTC).>
37 <b>GROUP OF #1, #3 AND #5 CYLINDERS.</b>	Is there any fault in #1, #3 and #5 cylinders?	Repair or replace faulty parts. NOTE: Check the following items. • Spark plug • Ignition coil • Fuel injector • Compression ratio • Skipping timing chain teeth	Check DTC P0171, P0172, P0174 or P0175 using "List of Diagnostic Trouble Code (DTC)". <Ref. to EN(H6DO)(diag)-89, List of Diagnostic Trouble Code (DTC).>
38 <b>GROUP OF #2, #4 AND #6 CYLINDERS.</b>	Is there any fault in #2, #4 and #6 cylinders?	Repair or replace faulty parts. NOTE: Check the following items. • Spark plug • Ignition coil • Fuel injector • Compression ratio • Skipping timing chain teeth	Check DTC P0171, P0172, P0174 or P0175 using "List of Diagnostic Trouble Code (DTC)". <Ref. to EN(H6DO)(diag)-89, List of Diagnostic Trouble Code (DTC).>
39 <b>CYLINDER AT RANDOM.</b>	Is the engine idle rough?	Check DTC P0171, P0172, P0174 or P0175 using "List of Diagnostic Trouble Code (DTC)". <Ref. to EN(H6DO)(diag)-89, List of Diagnostic Trouble Code (DTC).>	Repair or replace faulty parts. NOTE: Check the following items. • Spark plug • Ignition coil • Fuel injector • Compression ratio

# Diagnostic Procedure with Diagnostic Trouble Code (DTC)

ENGINE (DIAGNOSTICS)

## FT:DTC P2227 BAROMETRIC PRESSURE CIRCUIT RANGE/PERFORMANCE

### DTC DETECTING CONDITION:

- Detected when two consecutive driving cycles with fault occur.
- GENERAL DESCRIPTION <Ref. to GD(H6DO)-238, DTC P2227 BAROMETRIC PRESSURE CIRCUIT RANGE/PERFORMANCE, Diagnostic Trouble Code (DTC) Detecting Criteria.>

### CAUTION:

After servicing or replacing faulty parts, perform Clear Memory Mode <Ref. to EN(H6DO)(diag)-62, OPERATION, Clear Memory Mode.>, and Inspection Mode <Ref. to EN(H6DO)(diag)-47, PROCEDURE, Inspection Mode.>.

Step	Check	Yes	No
1 CHECK FOR ANY OTHER DTC ON DISPLAY.	Is any other DTC displayed?	Check DTC using "List of Diagnostic Trouble Code (DTC)". <Ref. to EN(H6DO)(diag)-89, List of Diagnostic Trouble Code (DTC).>	Replace the ECM. <Ref. to FU(H6DO)-51, Engine Control Module (ECM).> NOTE: The barometric pressure sensor is built into the ECM.

## FU:DTC P2228 BAROMETRIC PRESSURE CIRCUIT LOW

### DTC DETECTING CONDITION:

- Immediately at fault recognition
- GENERAL DESCRIPTION <Ref. to GD(H6DO)-239, DTC P2228 BAROMETRIC PRESSURE CIRCUIT LOW, Diagnostic Trouble Code (DTC) Detecting Criteria.>

### CAUTION:

After servicing or replacing faulty parts, perform Clear Memory Mode <Ref. to EN(H6DO)(diag)-62, OPERATION, Clear Memory Mode.>, and Inspection Mode <Ref. to EN(H6DO)(diag)-47, PROCEDURE, Inspection Mode.>.

Step	Check	Yes	No
1 CHECK FOR ANY OTHER DTC ON DISPLAY.	Is any other DTC displayed?	Check DTC using "List of Diagnostic Trouble Code (DTC)". <Ref. to EN(H6DO)(diag)-89, List of Diagnostic Trouble Code (DTC).>	Replace the ECM. <Ref. to FU(H6DO)-51, Engine Control Module (ECM).> NOTE: The barometric pressure sensor is built into the ECM.



# Diagnostic Procedure with Diagnostic Trouble Code (DTC)

ENGINE (DIAGNOSTICS)

## FV:DTC P2229 BAROMETRIC PRESSURE CIRCUIT HIGH

### DTC DETECTING CONDITION:

- Immediately at fault recognition
- GENERAL DESCRIPTION <Ref. to GD(H6DO)-240, DTC P2229 BAROMETRIC PRESSURE CIRCUIT HIGH, Diagnostic Trouble Code (DTC) Detecting Criteria.>

### CAUTION:

After servicing or replacing faulty parts, perform Clear Memory Mode <Ref. to EN(H6DO)(diag)-62, OPERATION, Clear Memory Mode.>, and Inspection Mode <Ref. to EN(H6DO)(diag)-47, PROCEDURE, Inspection Mode.>.

Step	Check	Yes	No
1 CHECK FOR ANY OTHER DTC ON DISPLAY.	Is any other DTC displayed?	Check DTC using "List of Diagnostic Trouble Code (DTC)". <Ref. to EN(H6DO)(diag)-89, List of Diagnostic Trouble Code (DTC).>	Replace the ECM. <Ref. to FU(H6DO)-51, Engine Control Module (ECM).> NOTE: The barometric pressure sensor is built into the ECM.

# Diagnostic Procedure with Diagnostic Trouble Code (DTC)

ENGINE (DIAGNOSTICS)

## FW:DTC P2401 EVAPORATIVE EMISSION SYSTEM LEAK DETECTION PUMP CONTROL CIRCUIT LOW

### DTC DETECTING CONDITION:

- Immediately at fault recognition
- GENERAL DESCRIPTION <Ref. to GD(H6DO)-241, DTC P2401 EVAPORATIVE EMISSION SYSTEM LEAK DETECTION PUMP CONTROL CIRCUIT LOW, Diagnostic Trouble Code (DTC) Detecting Criteria.>

### CAUTION:

After servicing or replacing faulty parts, perform Clear Memory Mode <Ref. to EN(H6DO)(diag)-62, OPERATION, Clear Memory Mode.>, and Inspection Mode <Ref. to EN(H6DO)(diag)-47, PROCEDURE, Inspection Mode.>.

### WIRING DIAGRAM:

Engine electrical system <Ref. to WI-32, Engine Electrical System.>

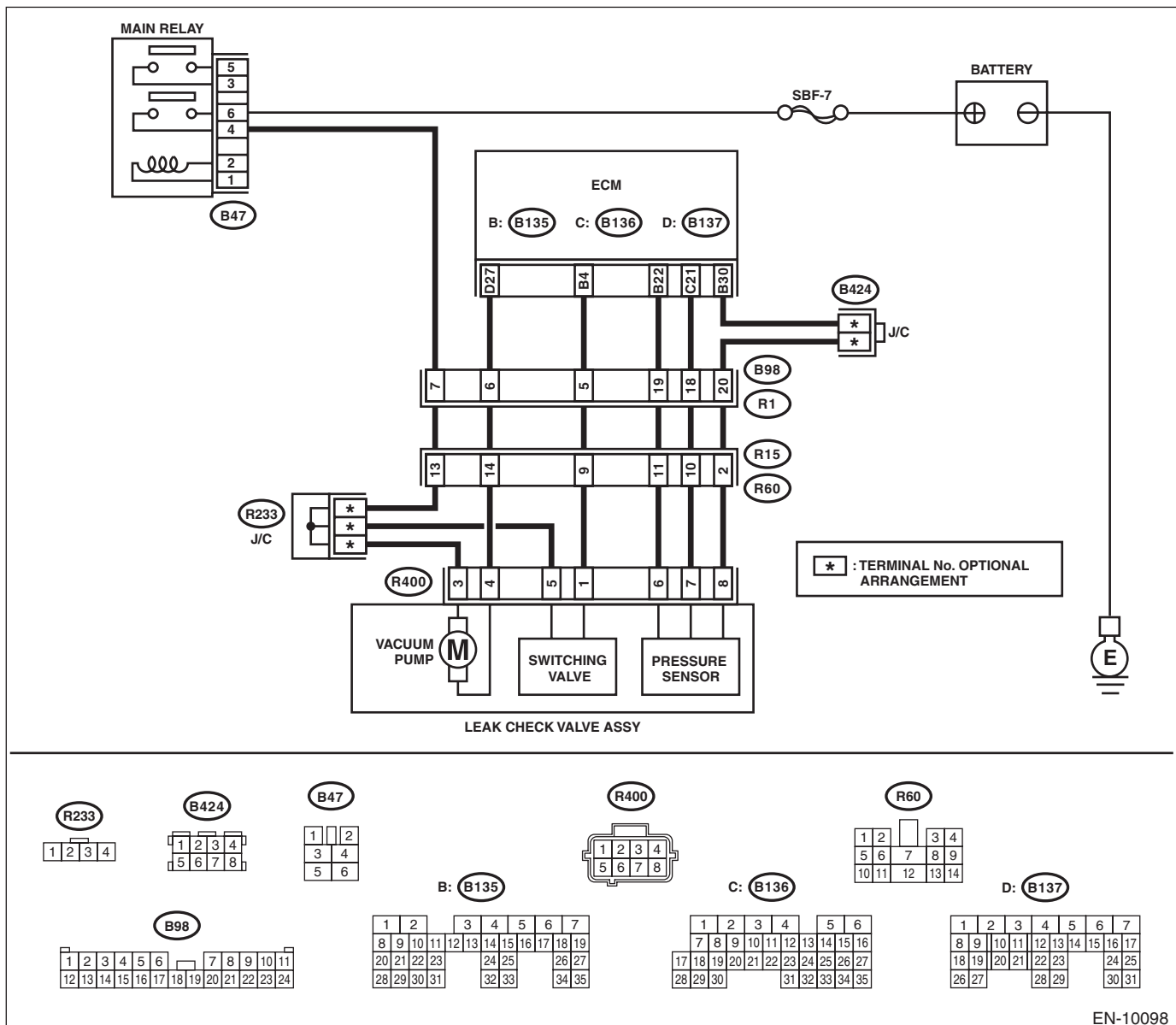

EN-10098

# Diagnostic Procedure with Diagnostic Trouble Code (DTC)

ENGINE (DIAGNOSTICS)

Step	Check	Yes	No
<p><b>1</b>     <b>CHECK HARNESS BETWEEN ECM AND LEAK CHECK VALVE ASSEMBLY CONNECTOR.</b>            1) Turn the ignition switch to ON.            2) Measure the voltage between ECM and chassis ground.  <b>Connector &amp; terminal</b>  <b>(B137) No. 27 (+) — Chassis ground (-):</b></p>	Is the voltage 10 V or more?	Go to step 2.	Go to step 3.
<p><b>2</b>     <b>CHECK FOR POOR CONTACT.</b>            Check for poor contact of ECM connector.</p>	Is there poor contact of ECM connector?	Repair the poor contact of ECM connector.	Even if DTC is detected, the circuit has returned to a normal condition at this time. Reproduce the failure, and then perform the diagnosis again.  <b>NOTE:</b> In this case, temporary open or short circuit of harness or temporary poor contact of connector may be the cause.
<p><b>3</b>     <b>CHECK POWER SUPPLY TO LEAK CHECK VALVE ASSEMBLY.</b>            Measure the voltage between the leak check valve assembly connector and engine ground.  <b>Connector &amp; terminal</b>  <b>(R400) No. 3 (+) — Engine ground (-):</b></p>	Is the voltage 10 V or more?	Go to step 4.	Repair the power supply circuit.
<p><b>4</b>     <b>CHECK HARNESS BETWEEN ECM AND LEAK CHECK VALVE ASSEMBLY CONNECTOR.</b>            1) Turn the ignition switch to OFF.            2) Disconnect the connector from ECM and the leak check valve assembly.            3) Measure the resistance between leak check valve assembly and chassis ground.  <b>Connector &amp; terminal</b>  <b>(R400) No. 4 — Chassis ground:</b></p>	Is the resistance 1 M $\Omega$ or more?	Go to step 5.	Repair the short circuit to ground in harness between ECM and leak check valve assembly connector.
<p><b>5</b>     <b>CHECK HARNESS BETWEEN ECM AND LEAK CHECK VALVE ASSEMBLY CONNECTOR.</b>            Measure the resistance of harness between ECM and the leak check valve assembly connector.  <b>Connector &amp; terminal</b>  <b>(B137) No. 27 — (R400) No. 4:</b></p>	Is the resistance less than 1 $\Omega$ ?	Go to step 6.	Repair the harness and connector.  <b>NOTE:</b> In this case, repair the following item: <ul style="list-style-type: none"> <li>• Open circuit in harness between ECM and the leak check valve assembly connector</li> <li>• Poor contact of coupling connector</li> </ul>
<p><b>6</b>     <b>CHECK LEAK CHECK VALVE ASSEMBLY.</b>            Check the vacuum pump of the leak check valve assembly. &lt;Ref. to EC(H6DO)-14, CHECK VACUUM PUMP, INSPECTION, Leak Check Valve Assembly.&gt;</p>	Is the vacuum pump of the leak check valve assembly OK?	Repair the poor contact in the leak check valve assembly connector.	Replace the leak check valve assembly. <Ref. to EC(H6DO)-12, Leak Check Valve Assembly.>

# Diagnostic Procedure with Diagnostic Trouble Code (DTC)

ENGINE (DIAGNOSTICS)

## FX:DTC P2402 EVAPORATIVE EMISSION SYSTEM LEAK DETECTION PUMP CONTROL CIRCUIT HIGH

### DTC DETECTING CONDITION:

- Immediately at fault recognition
- GENERAL DESCRIPTION <Ref. to GD(H6DO)-243, DTC P2402 EVAPORATIVE EMISSION SYSTEM LEAK DETECTION PUMP CONTROL CIRCUIT HIGH, Diagnostic Trouble Code (DTC) Detecting Criteria.>

### CAUTION:

After servicing or replacing faulty parts, perform Clear Memory Mode <Ref. to EN(H6DO)(diag)-62, OPERATION, Clear Memory Mode.>, and Inspection Mode <Ref. to EN(H6DO)(diag)-47, PROCEDURE, Inspection Mode.>.

### WIRING DIAGRAM:

Engine electrical system <Ref. to WI-32, Engine Electrical System.>

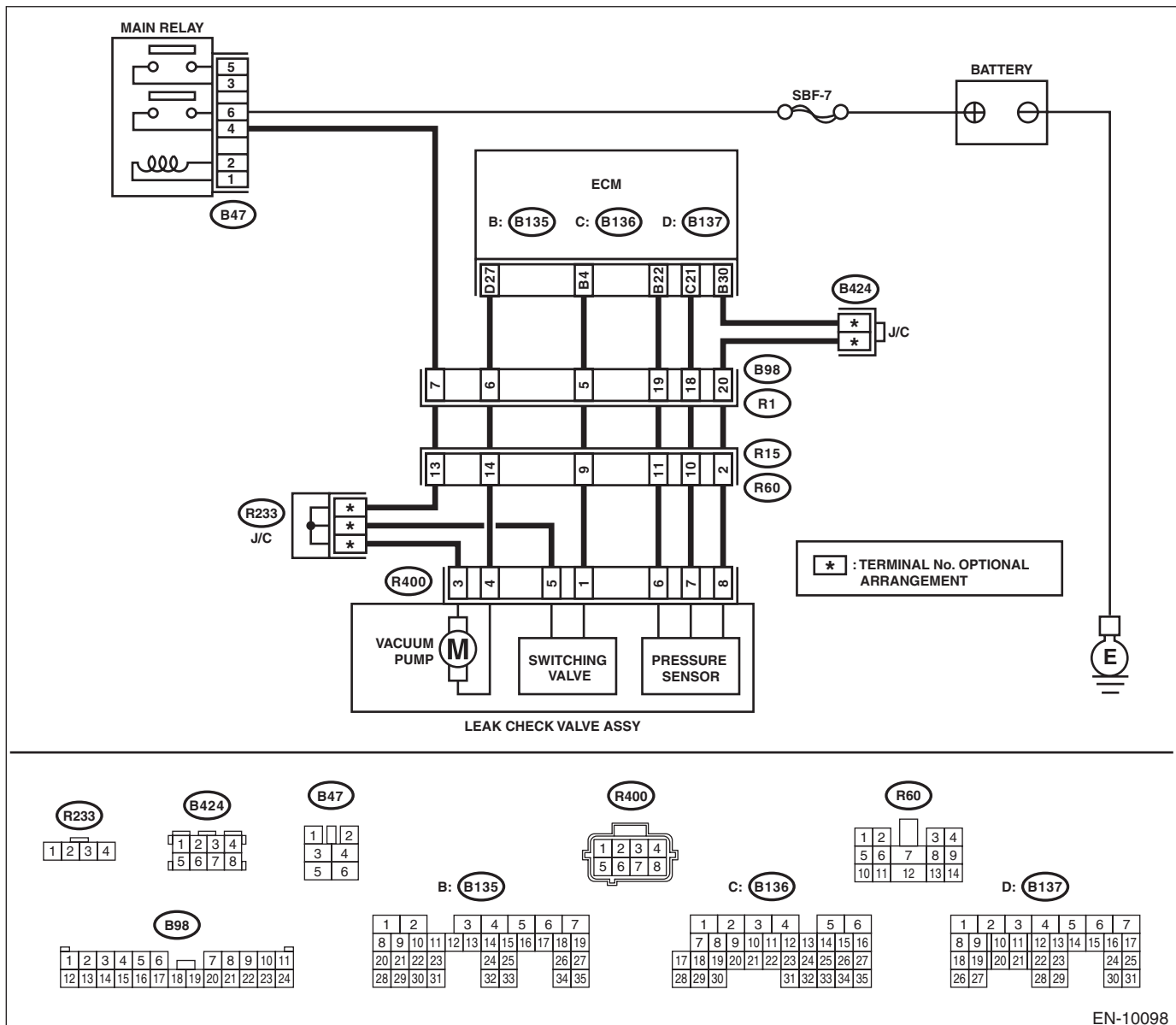

EN-10098

# Diagnostic Procedure with Diagnostic Trouble Code (DTC)

ENGINE (DIAGNOSTICS)

	Step	Check	Yes	No
<b>1</b> <b>CHECK HARNESS BETWEEN ECM AND LEAK CHECK VALVE ASSEMBLY CONNECTOR.</b> 1) Turn the ignition switch to OFF. 2) Disconnect the connector from the leak check valve assembly. 3) Turn the ignition switch to ON. 4) Measure the voltage between leak check valve assembly and chassis ground. <b>Connector &amp; terminal</b> <b>(R400) No. 4 (+) — Chassis ground (-):</b>	Is the voltage 10 V or more?	Repair the short circuit to power in harness between ECM and leak check valve assembly connector.	Go to step 2.	
<b>2</b> <b>CHECK LEAK CHECK VALVE ASSEMBLY.</b> 1) Turn the ignition switch to OFF. 2) Check the vacuum pump of the leak check valve assembly. <Ref. to EC(H6DO)-14, CHECK VACUUM PUMP, INSPECTION, Leak Check Valve Assembly.>	Is the vacuum pump of the leak check valve assembly OK?	Repair the poor contact in the leak check valve assembly connector.	Replace the leak check valve assembly. <Ref. to EC(H6DO)-12, Leak Check Valve Assembly.>	

# Diagnostic Procedure with Diagnostic Trouble Code (DTC)

ENGINE (DIAGNOSTICS)

## FY:DTC P2404 EVAPORATIVE EMISSION SYSTEM LEAK DETECTION PUMP SENSE CIRCUIT RANGE/PERFORMANCE

### DTC DETECTING CONDITION:

- Detected when two consecutive driving cycles with fault occur.
- GENERAL DESCRIPTION <Ref. to GD(H6DO)-244, DTC P2404 EVAPORATIVE EMISSION SYSTEM LEAK DETECTION PUMP SENSE CIRCUIT RANGE/PERFORMANCE, Diagnostic Trouble Code (DTC) Detecting Criteria.>

### CAUTION:

After servicing or replacing faulty parts, perform Clear Memory Mode <Ref. to EN(H6DO)(diag)-62, OPERATION, Clear Memory Mode.>, and Inspection Mode <Ref. to EN(H6DO)(diag)-47, PROCEDURE, Inspection Mode.>.

### WIRING DIAGRAM:

Engine electrical system <Ref. to WI-32, Engine Electrical System.>

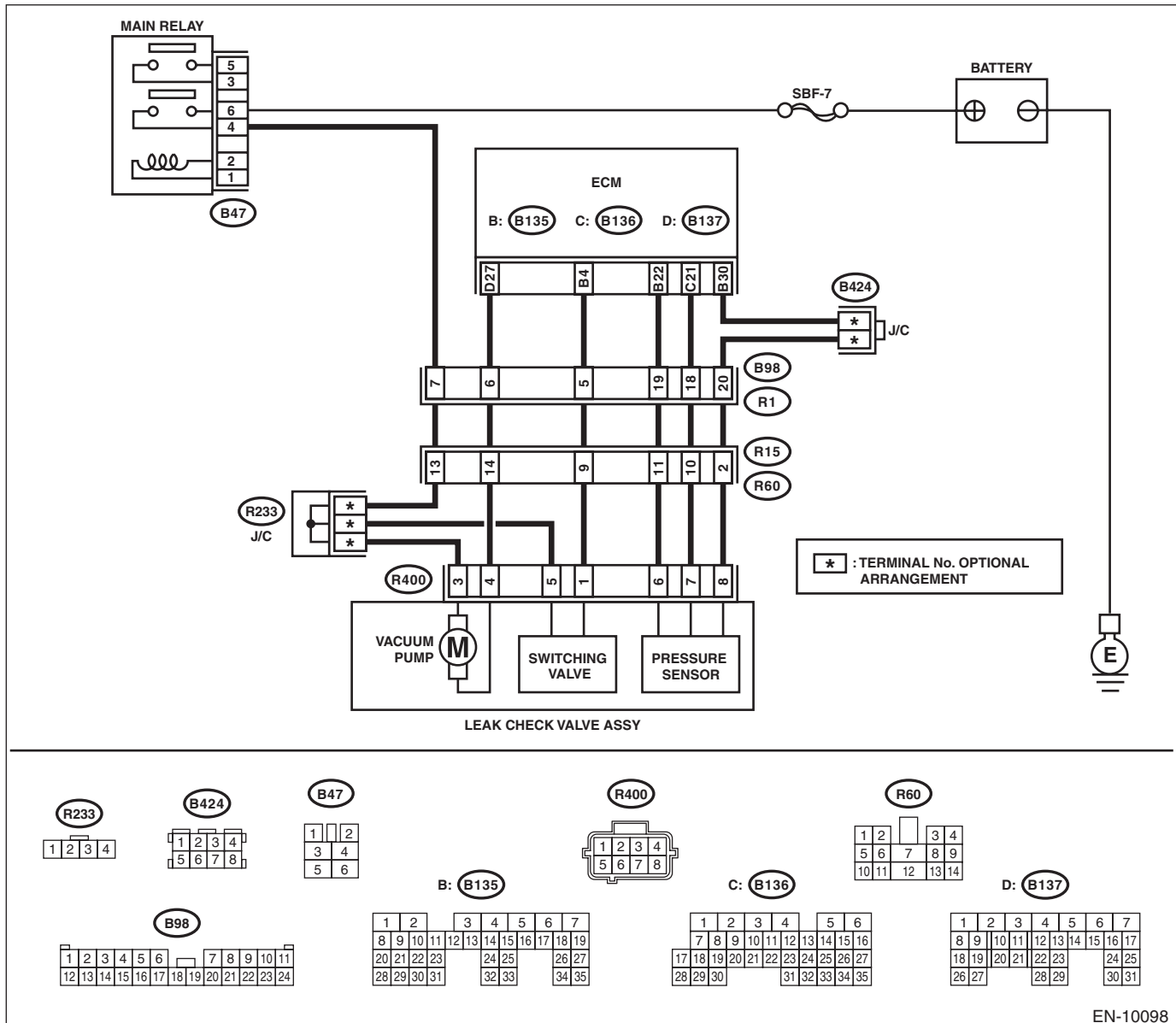

EN-10098

# Diagnostic Procedure with Diagnostic Trouble Code (DTC)

ENGINE (DIAGNOSTICS)

Step	Check	Yes	No
1	<b>CHECK FOR ANY OTHER DTC ON DISPLAY.</b>	Is any other DTC displayed?	Check the appropriate DTC using the "List of Diagnostic Trouble Code (DTC)". <Ref. to EN(H6DO)(diag)-89, List of Diagnostic Trouble Code (DTC).>
2	<b>CHECK ELCM PUMP.</b> Operate the ELCM pump using the Subaru Select Monitor. NOTE: For detailed procedures, refer to "System Operation Check Mode". <Ref. to EN(H6DO)(diag)-64, System Operation Check Mode.>	Does the ELCM pump operate?	Go to step 6.
3	<b>CHECK POWER SUPPLY OF LEAK CHECK VALVE ASSEMBLY.</b> 1) Turn the ignition switch to OFF. 2) Disconnect the connector from the leak check valve assembly. 3) Turn the ignition switch to ON. 4) Measure the voltage between the leak check valve assembly connector and chassis ground. <b>Connector &amp; terminal</b> <b>(R400) No. 3 (+) — Chassis ground (-):</b>	Is the voltage 10 V or more?	Go to step 4.
4	<b>CHECK HARNESS BETWEEN ECM AND LEAK CHECK VALVE ASSEMBLY CONNECTOR.</b> 1) Turn the ignition switch to OFF. 2) Disconnect the connector from ECM. 3) Measure the resistance of harness between ECM and the leak check valve assembly connector. <b>Connector &amp; terminal</b> <b>(B137) No. 27 — (R400) No. 4:</b>	Is the resistance less than 1 Ω?	Go to step 5.
5	<b>CHECK HARNESS BETWEEN ECM AND LEAK CHECK VALVE ASSEMBLY CONNECTOR.</b> 1) Measure the resistance of harness between ECM and chassis ground. <b>Connector &amp; terminal</b> <b>(B137) No. 27 — Chassis ground:</b>	Is the resistance 1 MΩ or more?	Replace the leak check valve assembly. <Ref. to EC(H6DO)-12, Leak Check Valve Assembly.>
6	<b>CHECK ELCM SWITCHING VALVE.</b> Operate the ELCM switching valve using the Subaru Select Monitor. NOTE: For detailed procedures, refer to "System Operation Check Mode". <Ref. to EN(H6DO)(diag)-64, System Operation Check Mode.>	Does the ELCM switching valve operate?	Go to step 10.

# Diagnostic Procedure with Diagnostic Trouble Code (DTC)

ENGINE (DIAGNOSTICS)

Step	Check	Yes	No
<p><b>7</b></p> <p><b>CHECK POWER SUPPLY OF LEAK CHECK VALVE ASSEMBLY.</b></p> <p>1) Turn the ignition switch to OFF.                      2) Disconnect the connector from the leak check valve assembly.                      3) Turn the ignition switch to ON.                      4) Measure the voltage between the leak check valve assembly connector and chassis ground.</p> <p><b>Connector &amp; terminal</b>  <b>(R400) No. 5 (+) — Chassis ground (-):</b></p>	<p>Is the voltage 10 V or more?</p>	<p>Go to step 8.</p>	<p>Repair the harness and connector.</p> <p><b>NOTE:</b>                      In this case, repair the following item:</p> <ul style="list-style-type: none"> <li>• Open circuit in harness between the main relay and the leak check valve assembly connector</li> <li>• Poor contact of main relay connector</li> <li>• Poor contact of coupling connector</li> </ul>
<p><b>8</b></p> <p><b>CHECK HARNESS BETWEEN ECM AND LEAK CHECK VALVE ASSEMBLY CONNECTOR.</b></p> <p>1) Turn the ignition switch to OFF.                      2) Disconnect the connector from ECM.                      3) Measure the resistance of harness between ECM and the leak check valve assembly connector.</p> <p><b>Connector &amp; terminal</b>  <b>(B135) No. 4 — (R400) No. 1:</b></p>	<p>Is the resistance less than 1 <math>\Omega</math>?</p>	<p>Go to step 9.</p>	<p>Repair the harness and connector.</p> <p><b>NOTE:</b>                      In this case, repair the following item:</p> <ul style="list-style-type: none"> <li>• Open circuit in harness between ECM and the leak check valve assembly connector</li> <li>• Poor contact of coupling connector</li> </ul>
<p><b>9</b></p> <p><b>CHECK HARNESS BETWEEN ECM AND LEAK CHECK VALVE ASSEMBLY CONNECTOR.</b></p> <p>1) Measure the resistance of harness between ECM and chassis ground.</p> <p><b>Connector &amp; terminal</b>  <b>(B135) No. 4 — Chassis ground:</b></p>	<p>Is the resistance 1 M<math>\Omega</math> or more?</p>	<p>Replace the leak check valve assembly. &lt;Ref. to EC(H6DO)-12, Leak Check Valve Assembly.&gt;</p>	<p>Repair the short circuit to ground in harness between ECM and leak check valve assembly connector.</p>
<p><b>10</b></p> <p><b>CHECK EVAPORATIVE EMISSION CONTROL SYSTEM.</b></p> <p>Perform drive cycle I. &lt;Ref. to EN(H6DO)(diag)-59, DRIVE CYCLE H, PROCEDURE, Drive Cycle.&gt;</p>	<p>Is DTC P2404 displayed on the display?</p>	<p>Replace the leak check valve assembly. &lt;Ref. to EC(H6DO)-12, Leak Check Valve Assembly.&gt;</p>	<p>Even if DTC is detected, the circuit has returned to a normal condition at this time. Reproduce the failure, and then perform the diagnosis again.</p> <p><b>NOTE:</b>                      In this case, temporary poor contact of connector, temporary open or short circuit of harness may be the cause.</p>



# Diagnostic Procedure with Diagnostic Trouble Code (DTC)

ENGINE (DIAGNOSTICS)

## FZ: DTC P2419 EVAPORATIVE EMISSION SYSTEM SWITCHING VALVE CONTROL CIRCUIT LOW

### DTC DETECTING CONDITION:

- Immediately at fault recognition
- GENERAL DESCRIPTION <Ref. to GD(H6DO)-245, DTC P2419 EVAPORATIVE EMISSION SYSTEM SWITCHING VALVE CONTROL CIRCUIT LOW, Diagnostic Trouble Code (DTC) Detecting Criteria.>

### CAUTION:

After servicing or replacing faulty parts, perform Clear Memory Mode <Ref. to EN(H6DO)(diag)-62, OPERATION, Clear Memory Mode.>, and Inspection Mode <Ref. to EN(H6DO)(diag)-47, PROCEDURE, Inspection Mode.>.

### WIRING DIAGRAM:

Engine electrical system <Ref. to WI-32, Engine Electrical System.>

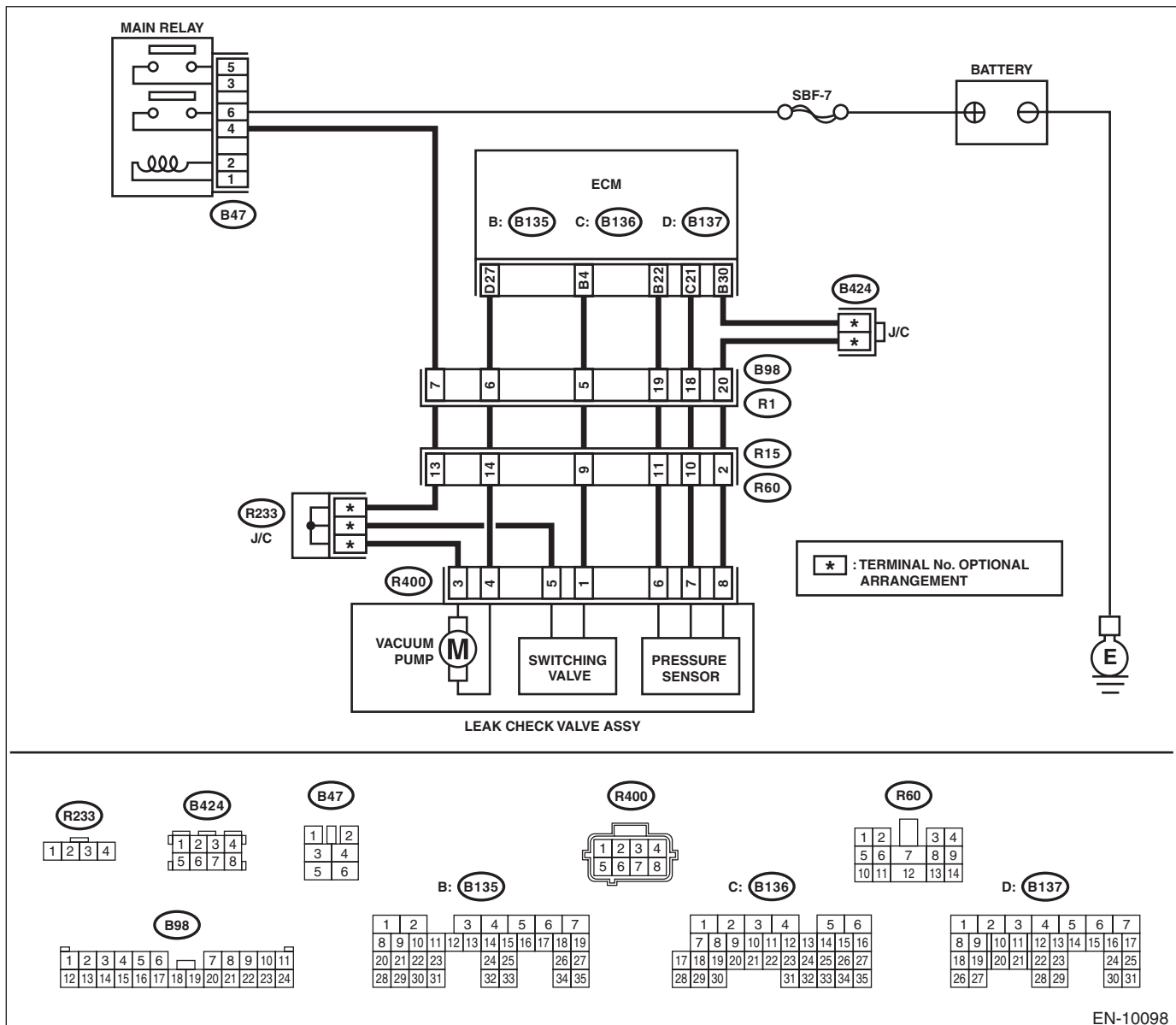

EN-10098

# Diagnostic Procedure with Diagnostic Trouble Code (DTC)

ENGINE (DIAGNOSTICS)

Step	Check	Yes	No
<p><b>1</b>     <b>CHECK HARNESS BETWEEN ECM AND LEAK CHECK VALVE ASSEMBLY CONNECTOR.</b>            1) Turn the ignition switch to ON.            2) Measure the voltage between ECM and chassis ground.  <b>Connector &amp; terminal</b>  <b>(B135) No. 4 (+) — Chassis ground (-):</b></p>	Is the voltage 10 V or more?	Go to step 2.	Go to step 3.
<p><b>2</b>     <b>CHECK FOR POOR CONTACT.</b>            Check for poor contact of ECM connector.</p>	Is there poor contact of ECM connector?	Repair the poor contact of ECM connector.	Even if DTC is detected, the circuit has returned to a normal condition at this time. Reproduce the failure, and then perform the diagnosis again.  <b>NOTE:</b> In this case, temporary open or short circuit of harness or temporary poor contact of connector may be the cause.
<p><b>3</b>     <b>CHECK POWER SUPPLY TO LEAK CHECK VALVE ASSEMBLY.</b>            Measure the voltage between the leak check valve assembly connector and engine ground.  <b>Connector &amp; terminal</b>  <b>(R400) No. 5 (+) — Engine ground (-):</b></p>	Is the voltage 10 V or more?	Go to step 4.	Repair the power supply circuit.
<p><b>4</b>     <b>CHECK HARNESS BETWEEN ECM AND LEAK CHECK VALVE ASSEMBLY CONNECTOR.</b>            1) Turn the ignition switch to OFF.            2) Disconnect the connector from ECM and the leak check valve assembly.            3) Measure the resistance between leak check valve assembly and chassis ground.  <b>Connector &amp; terminal</b>  <b>(R400) No. 1 — Chassis ground:</b></p>	Is the resistance 1 M $\Omega$ or more?	Go to step 5.	Repair the short circuit to ground in harness between ECM and leak check valve assembly connector.
<p><b>5</b>     <b>CHECK HARNESS BETWEEN ECM AND LEAK CHECK VALVE ASSEMBLY CONNECTOR.</b>            Measure the resistance of harness between ECM and the leak check valve assembly connector.  <b>Connector &amp; terminal</b>  <b>(B135) No. 4 — (R400) No. 1:</b></p>	Is the resistance less than 1 $\Omega$ ?	Go to step 6.	Repair the harness and connector.  <b>NOTE:</b> In this case, repair the following item: <ul style="list-style-type: none"> <li>• Open circuit in harness between ECM and the leak check valve assembly connector</li> <li>• Poor contact of coupling connector</li> </ul>
<p><b>6</b>     <b>CHECK LEAK CHECK VALVE ASSEMBLY.</b>            Check the switching valve of the leak check valve assembly. &lt;Ref. to EC(H6DO)-13, CHECK SWITCHING VALVE, INSPECTION, Leak Check Valve Assembly.&gt;</p>	Is the switching valve of the leak check valve assembly OK?	Repair the poor contact in the leak check valve assembly connector.	Replace the leak check valve assembly. <Ref. to EC(H6DO)-12, Leak Check Valve Assembly.>

# Diagnostic Procedure with Diagnostic Trouble Code (DTC)

ENGINE (DIAGNOSTICS)

## GA:DTC P2420 EVAPORATIVE EMISSION SYSTEM SWITCHING VALVE CONTROL CIRCUIT HIGH

### DTC DETECTING CONDITION:

- Immediately at fault recognition
- GENERAL DESCRIPTION <Ref. to GD(H6DO)-247, DTC P2420 EVAPORATIVE EMISSION SYSTEM SWITCHING VALVE CONTROL CIRCUIT HIGH, Diagnostic Trouble Code (DTC) Detecting Criteria.>

### CAUTION:

After servicing or replacing faulty parts, perform Clear Memory Mode <Ref. to EN(H6DO)(diag)-62, OPERATION, Clear Memory Mode.>, and Inspection Mode <Ref. to EN(H6DO)(diag)-47, PROCEDURE, Inspection Mode.>.

### WIRING DIAGRAM:

Engine electrical system <Ref. to WI-32, Engine Electrical System.>

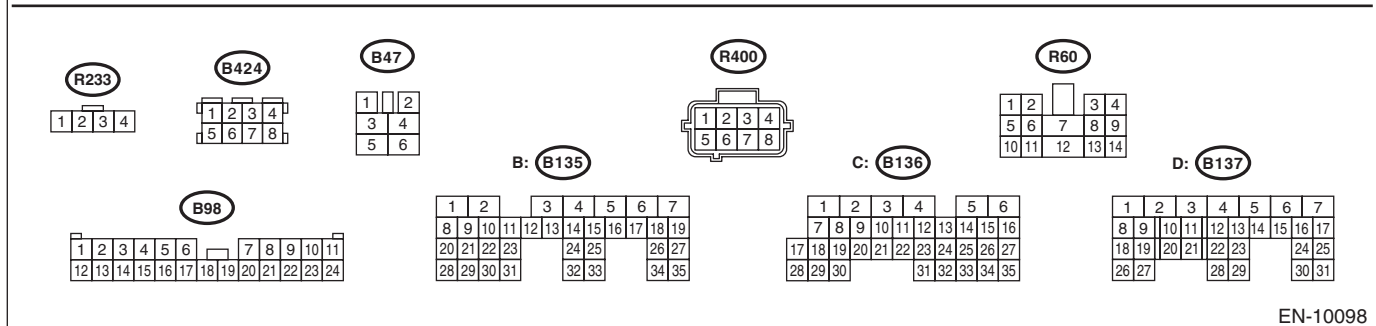
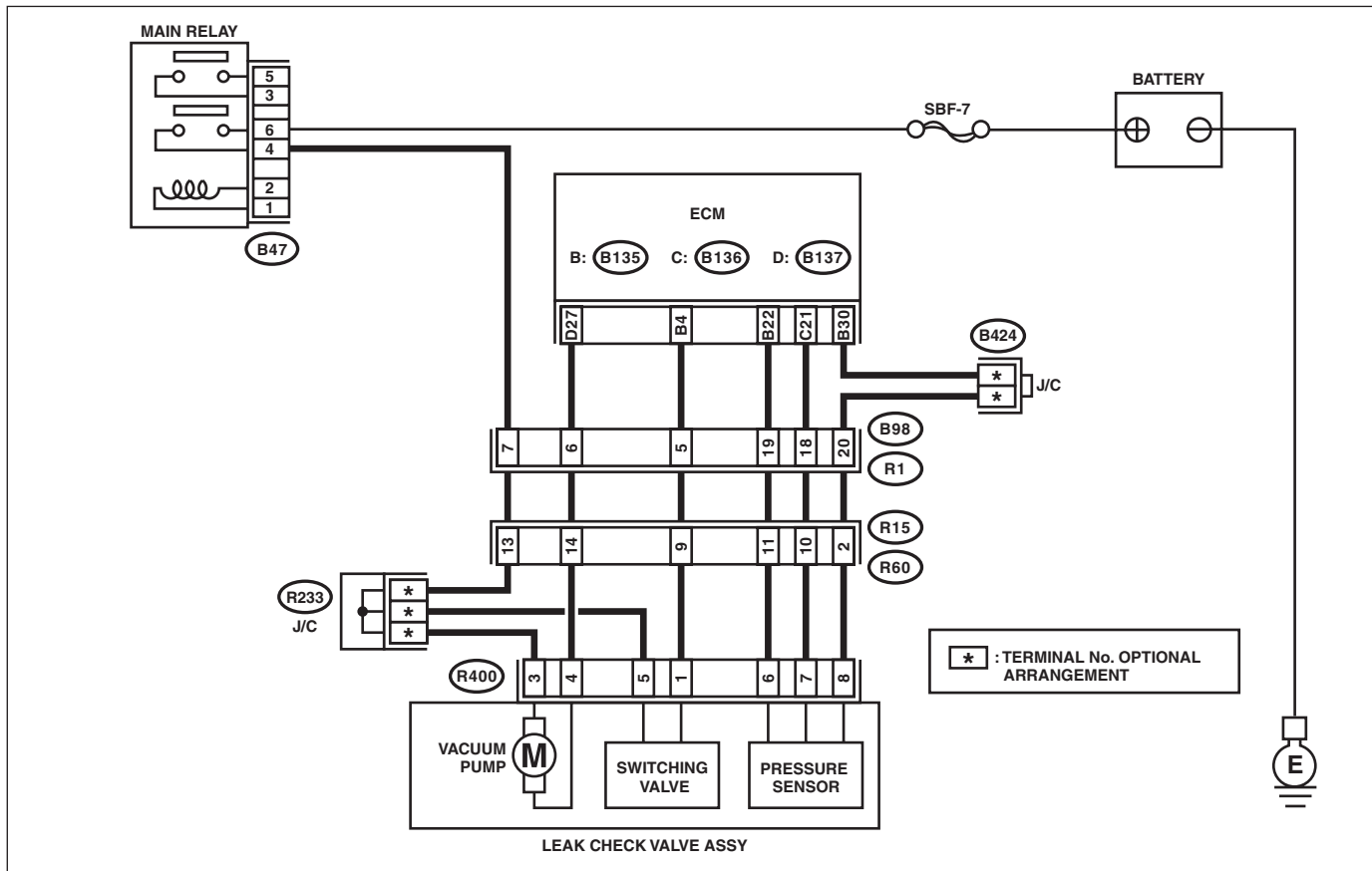

EN-10098

# Diagnostic Procedure with Diagnostic Trouble Code (DTC)

ENGINE (DIAGNOSTICS)

Step	Check	Yes	No
<p><b>1</b>    <b>CHECK HARNESS BETWEEN ECM AND LEAK CHECK VALVE ASSEMBLY CONNECTOR.</b>            1) Turn the ignition switch to OFF.            2) Disconnect the connector from the leak check valve assembly.            3) Turn the ignition switch to ON.            4) Measure the voltage between leak check valve assembly and chassis ground.  <b>Connector &amp; terminal</b>  <b>(R400) No. 1 (+) — Chassis ground (-):</b></p>	<p>Is the voltage 10 V or more?</p>	<p>Repair the short circuit to power in harness between ECM and leak check valve assembly connector.</p>	<p>Go to step 2.</p>
<p><b>2</b>    <b>CHECK LEAK CHECK VALVE ASSEMBLY.</b>            1) Turn the ignition switch to OFF.            2) Check the switching valve of the leak check valve assembly. &lt;Ref. to EC(H6DO)-13, CHECK SWITCHING VALVE, INSPECTION, Leak Check Valve Assembly.&gt;</p>	<p>Is the switching valve of the leak check valve assembly OK?</p>	<p>Repair the poor contact in the leak check valve assembly connector.</p>	<p>Replace the leak check valve assembly. &lt;Ref. to EC(H6DO)-12, Leak Check Valve Assembly.&gt;</p>

# Diagnostic Procedure with Diagnostic Trouble Code (DTC)

ENGINE (DIAGNOSTICS)

## GB:DTC P2610 ECM/PCM INTERNAL ENGINE OFF TIMER PERFORMANCE

### DTC DETECTING CONDITION:

- Detected when two consecutive driving cycles with fault occur.
- GENERAL DESCRIPTION <Ref. to GD(H6DO)-249, DTC P2610 ECM/PCM INTERNAL ENGINE OFF TIMER PERFORMANCE, Diagnostic Trouble Code (DTC) Detecting Criteria.>

### CAUTION:

After servicing or replacing faulty parts, perform Clear Memory Mode <Ref. to EN(H6DO)(diag)-62, OPERATION, Clear Memory Mode.>, and Inspection Mode <Ref. to EN(H6DO)(diag)-47, PROCEDURE, Inspection Mode.>.

Step	Check	Yes	No
1 CHECK FOR ANY OTHER DTC ON DISPLAY.	Is any other DTC displayed?	Check DTC using "List of Diagnostic Trouble Code (DTC)". <Ref. to EN(H6DO)(diag)-89, List of Diagnostic Trouble Code (DTC).>	Replace the ECM. <Ref. to FU(H6DO)-51, Engine Control Module (ECM).> NOTE: The soaking timer IC is built into the ECM.

## GC:DTC U0073 CAN FAILURE, BUS 'OFF' DETECTION

### NOTE:

For the diagnostic procedure, refer to LAN section. <Ref. to LAN(diag)-2, Basic Diagnostic Procedure.>

## GD:DTC U0101 CAN (TCU) DATA NOT LOADED

### NOTE:

For the diagnostic procedure, refer to LAN section. <Ref. to LAN(diag)-2, Basic Diagnostic Procedure.>

## GE:DTC U0122 CAN (VDC) DATA NOT LOADED

### NOTE:

For the diagnostic procedure, refer to LAN section. <Ref. to LAN(diag)-2, Basic Diagnostic Procedure.>

## GF:DTC U0140 CAN (BCU) DATA NOT LOADED

### NOTE:

For the diagnostic procedure, refer to LAN section. <Ref. to LAN(diag)-2, Basic Diagnostic Procedure.>

## GG:DTC U0402 CAN (TCU) DATA ABNORMAL

### NOTE:

For the diagnostic procedure, refer to LAN section. <Ref. to LAN(diag)-2, Basic Diagnostic Procedure.>

## GH:DTC U0416 CAN (VDC) DATA ABNORMAL

### NOTE:

For the diagnostic procedure, refer to LAN section. <Ref. to LAN(diag)-2, Basic Diagnostic Procedure.>

## GI: DTC U0422 CAN (BCU) DATA ABNORMAL

### NOTE:

For the diagnostic procedure, refer to LAN section. <Ref. to LAN(diag)-2, Basic Diagnostic Procedure.>