

26. Fuel Level Sensor

A: REMOVAL

WARNING:

Place "NO OPEN FLAMES" signs near the working area.

CAUTION:

- Be careful not to spill fuel.
- If the fuel gauge indicates that two thirds or more of the fuel is remaining, be sure to drain fuel before starting work to avoid the fuel to spill.

NOTE:

The fuel level sensor is built in fuel pump assembly.

- 1) Remove the fuel pump assembly. <Ref. to FU(H6DO)-65, REMOVAL, Fuel Pump.>
- 2) Disconnect the fuel level sensor connector.

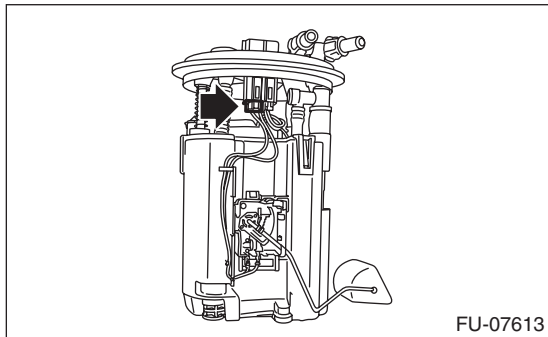

3) Slide the fuel level sensor in the direction of the arrow and remove the fuel level sensor by pressing the claw (A) of the fuel level sensor.

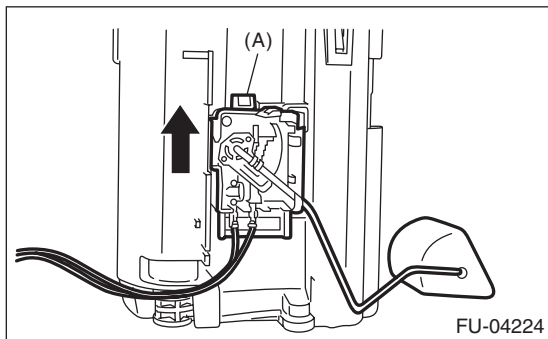

B: INSTALLATION

Install in the reverse order of removal.

C: INSPECTION

- 1) Check that the fuel level sensor has no damage.
- 2) Measure the fuel level sensor float position.

NOTE:

When inspecting the fuel level sensor, perform the work with the sensor installed to the fuel pump.

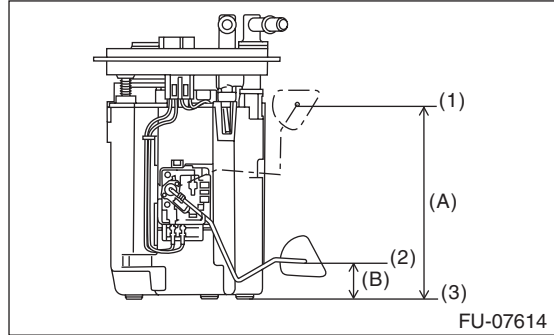

- (1) FULL
- (2) EMPTY
- (3) Fuel tank seating surface

Float position	Standard
FULL to Fuel tank seating surface (A)	135±4 mm (5.315±0.157 in)
EMPTY to Fuel tank seating surface (B)	23.7±4 mm (0.933±0.157 in)

3) Measure the resistance between fuel level sensor terminals.

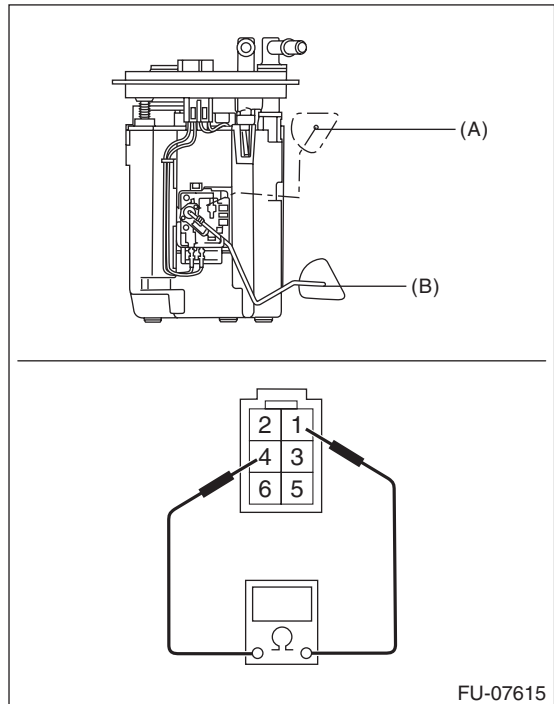

Float position	Terminal No.	Standard
FULL (A)	1 and 4	2.0±1.0 Ω
EMPTY (B)		31.9±1.0 Ω