

# Fuel Delivery and Evaporation Lines

FUEL INJECTION (FUEL SYSTEMS)

## 29. Fuel Delivery and Evaporation Lines

### A: REMOVAL

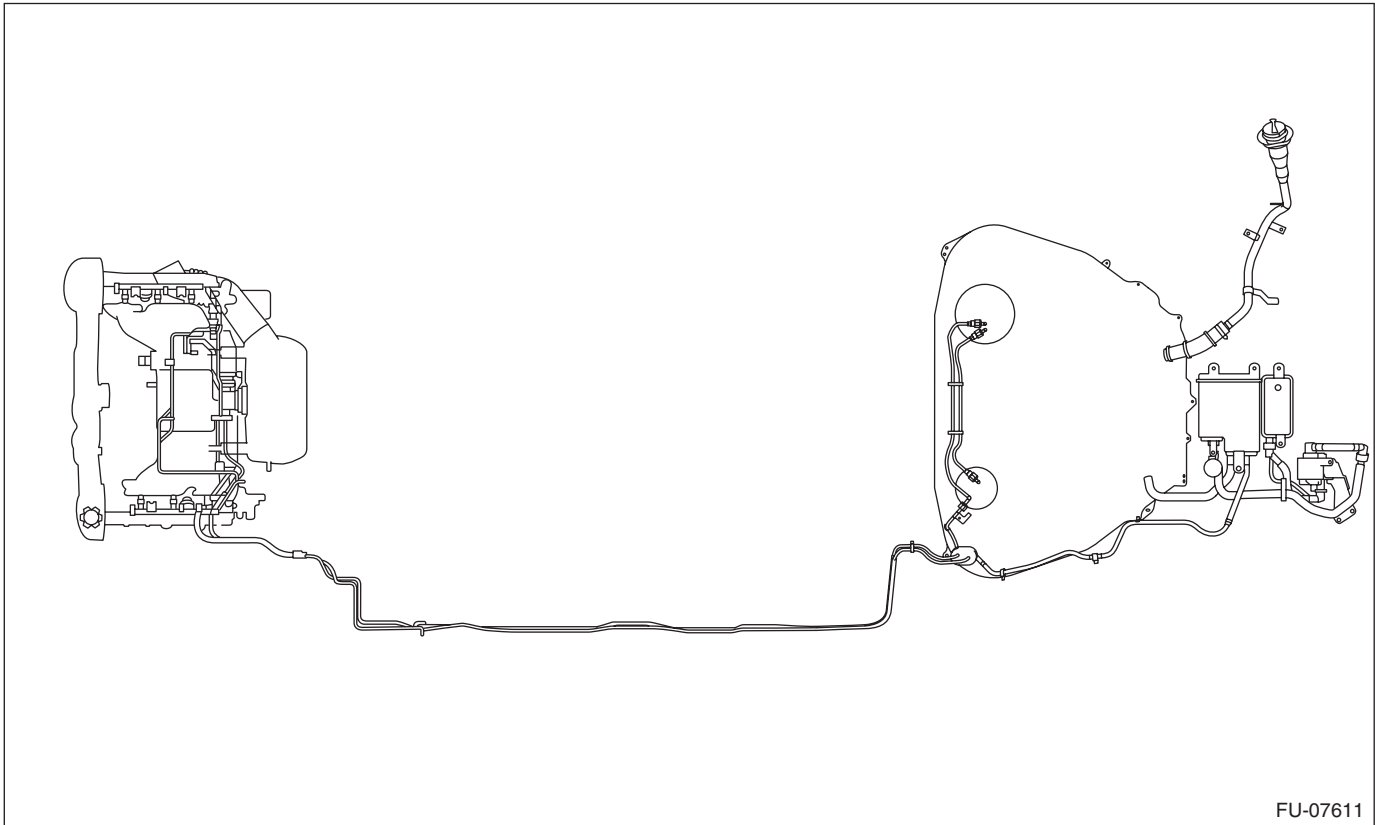

**WARNING:**  
Place “NO OPEN FLAMES” signs near the working area.

**CAUTION:**  
Be careful not to spill fuel.

- 1) Release the fuel pressure. <Ref. to FU(H6DO)-58, RELEASING OF FUEL PRESSURE, PROCEDURE, Fuel.>
- 2) Open the fuel filler lid and remove the fuel filler cap.
- 3) Remove the floor mat. <Ref. to EI-48, REMOVAL, Floor Mat.>
- 4) Disconnect the fuel delivery pipe and hose and the evaporation pipe and hose.
- 5) In the engine compartment, disconnect the fuel delivery hoses and evaporation hose.

**CAUTION:**

- Be careful not to spill fuel.
- Catch the fuel from hoses using a container or cloth.

- (1) Disconnect the quick connector of the fuel delivery line by pushing the ST in the direction of the arrow.

ST 42099AE00 QUICK CONNECTOR RELEASE

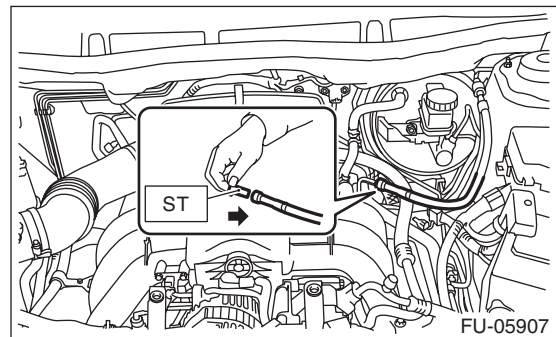

- (2) Remove the clip and disconnect the evaporation hose.
- 6) Remove the fuel tank. <Ref. to FU(H6DO)-60, REMOVAL, Fuel Tank.>
- 7) Disconnect the quick connector, and remove the fuel delivery tube and fuel sub delivery tube from the fuel tank.

# Fuel Delivery and Evaporation Lines

FUEL INJECTION (FUEL SYSTEMS)

- When using ST
  1. Attach ST to the pipe and push ST in the direction of arrow mark to disconnect the quick connector.

ST 42099AE000 QUICK CONNECTOR RELEASE

## CAUTION:

- Be careful not to spill fuel.
- Catch the fuel from hoses using a container or cloth.
- To disconnect the connector, hold (C) shown in the figure and pull in axial direction.
- If the connector and pipe are sticking to each other, push and pull the connector with ST pushed, and then pull the connector after it starts moving freely.
- When disconnecting the connector, do not bend or twist the tube forcibly. If the tube is bent, replace with a new part.

## NOTE:

Clean the pipe and quick connector, if they are covered with dust.

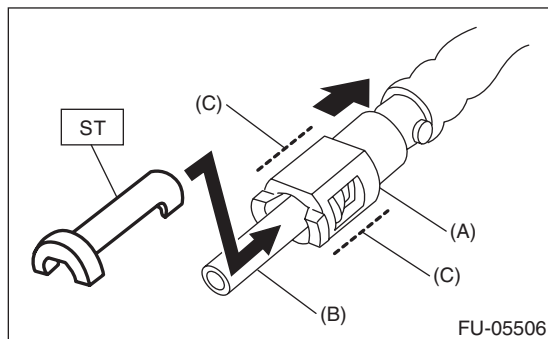

- (A) Quick connector
- (B) Pipe
- (C) Connector holding position

2. To prevent from damaging or entering foreign matter, wrap the pipes and quick connectors with plastic bag etc.

## CAUTION:

When reusing the retainer, do not disconnect the retainer from the connector.

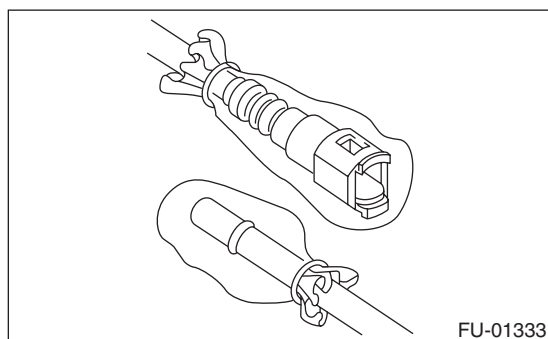

- When not using ST
  1. Push the retainer in the direction of the arrow, disconnect the quick connector from pipe.

## CAUTION:

- Be careful not to spill fuel.
- Catch the fuel from hoses using a container or cloth.
- To disconnect the connector, hold (D) shown in the figure and pull in axial direction.
- If the connector and pipe are sticking to each other, push and pull the connector with the retainer pushed in the direction of the arrow, and then pull the connector after it starts moving freely.
- When disconnecting the connector, do not bend or twist the tube forcibly. If the tube is bent, replace with a new part.

## NOTE:

Clean the pipe and quick connector, if they are covered with dust.

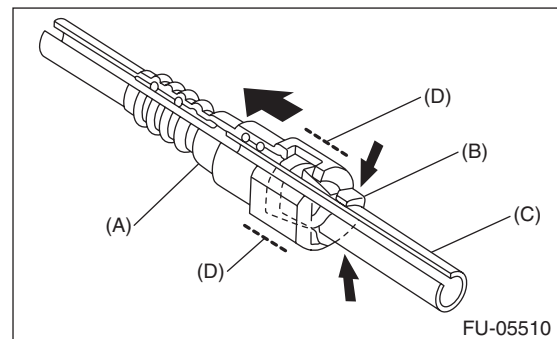

- (A) Quick connector
- (B) Retainer
- (C) Pipe
- (D) Connector holding position

2. To prevent from damaging or entering foreign matter, wrap the pipes and quick connectors with plastic bag etc.

## CAUTION:

When reusing the retainer, do not disconnect the retainer from the pipe.

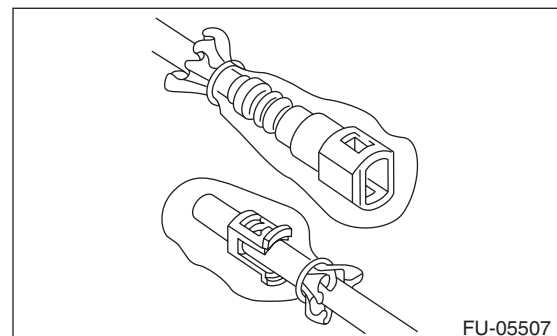

# Fuel Delivery and Evaporation Lines

## FUEL INJECTION (FUEL SYSTEMS)

### B: INSTALLATION

#### 1. CONNECTING THE FUEL LINE QUICK CONNECTOR

##### CAUTION:

- Make sure there are no damage or dust on connections. If necessary, clean seal surface of pipe.

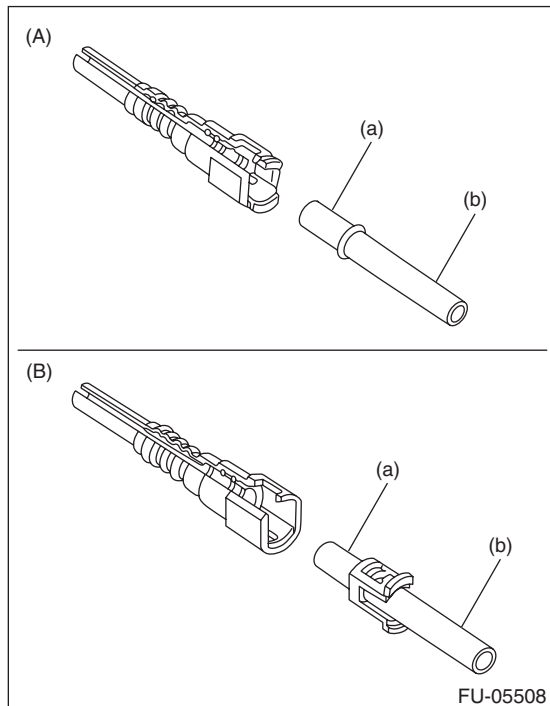

- (A) When removed using the ST
- (B) When removed without using the ST
- (a) Seal surface
- (b) Pipe

- When reusing the retainer, make sure that neither scratches nor deformation exist on the retainer. If it is faulty, use a new part.

1) Connect the quick connector to pipe.

##### CAUTION:

- Make sure that the quick connector is securely connected.

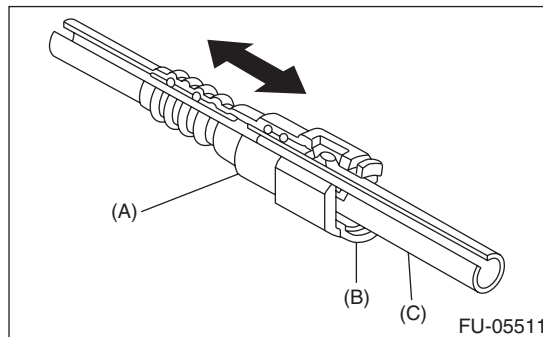

- (A) Quick connector
- (B) Retainer
- (C) Pipe

- Make sure the two retainer pawls are engaged in their mating positions in the quick connector.
- Be sure to inspect tubes and their connections for any leakage of fuel.
- To connect the connector, hold (d) shown in the figure and push in axial direction.

# Fuel Delivery and Evaporation Lines

FUEL INJECTION (FUEL SYSTEMS)

- When connecting the connector, do not bend or twist the tube forcibly. If the tube is bent, replace with a new part.

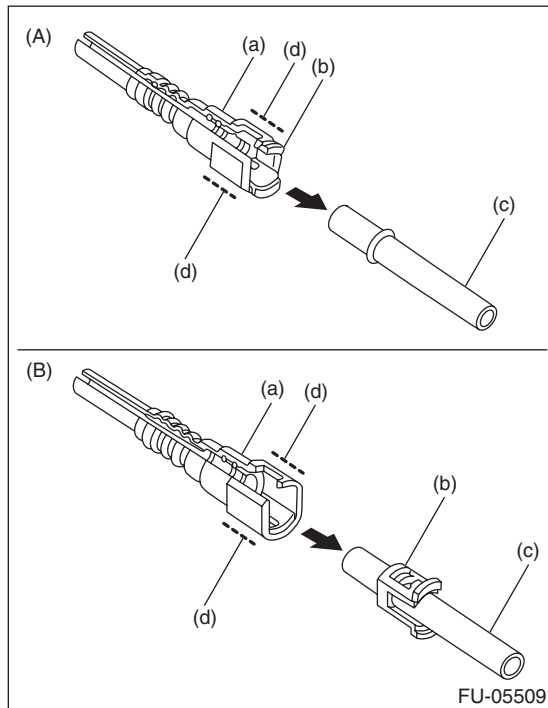

- (A) When removed using the ST  
 (B) When removed without using the ST  
 (a) Quick connector  
 (b) Retainer  
 (c) Pipe  
 (d) Connector holding position

## 2. CONNECTING THE FUEL DELIVERY HOSE AND FUEL HOSE

Connect the fuel delivery hose or fuel hose as shown in the figure.

### CAUTION:

- If the connection portion has a spool or stopper, do not allow the end of the hose to bend or ride over by inserting the hose too deep.
- Be sure to inspect hoses and their connections for any leakage of fuel.

### NOTE:

Use new fuel delivery hose and fuel hose.

### Tightening torque:

$1.25 \text{ N}\cdot\text{m}$  (0.1 kgf-m, 0.9 ft-lb)

$L1: 2.5 \pm 1.5 \text{ mm}$  (0.098 ± 0.059 in)

$L2: 22.5 \pm 2.5 \text{ mm}$  (0.886 ± 0.098 in)

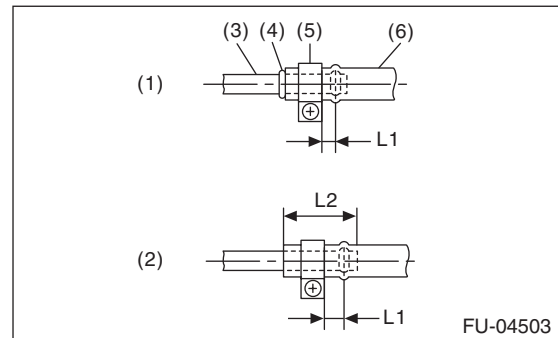

- (1) When there is a spool or bump  
 (2) When there is no spool or bump  
 (3) Pipe  
 (4) Spool or bump  
 (5) Clamp  
 (6) Hose

## 3. EVAPORATION HOSE CONNECTION

Connect the evaporation hose to the pipe with an overlap of 15 to 20 mm (0.59 to 0.79 in).

$L = 17.5 \pm 2.5 \text{ mm}$  (0.689 ± 0.098 in)

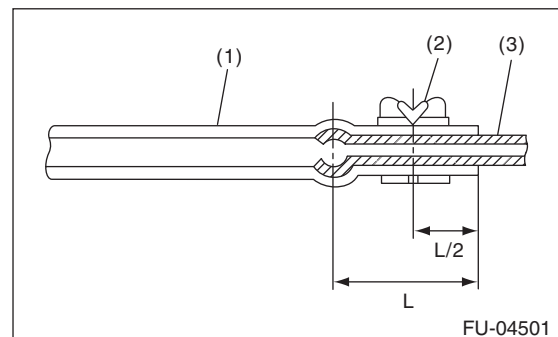

- (1) Hose  
 (2) Clip  
 (3) Pipe

## C: INSPECTION

- 1) Check that the fuel pipe has no deformation, cracks or other damages.
- 2) Check that the hose and tube have no cracks, damage or loose part.