

5. Crankshaft Position Sensor

A: REMOVAL

- 1) Remove the collector cover.
- 2) Disconnect the ground cable from battery.
- 3) Disconnect the brake booster vacuum hose from the intake manifold.

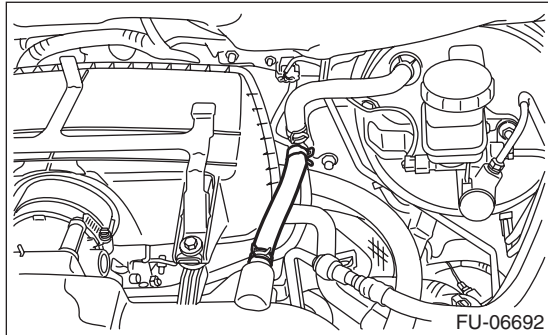

- 4) Loosen the clamp (A) which connects air intake chamber to throttle body.
- 5) Loosen the clamp (B) which connects intake boot to air intake chamber.
- 6) Remove the bolt (C) which secures air intake chamber and collector cover bracket to the stay.

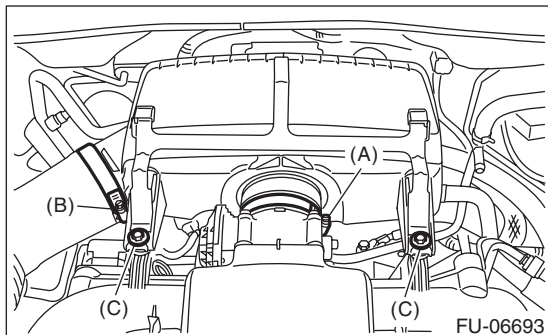

- 7) Remove the air intake chamber, and move it to the left side wheel apron.

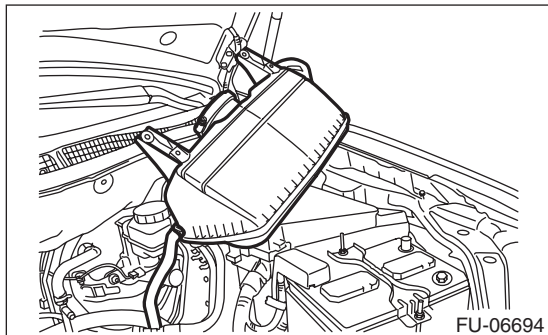

- 8) Remove the throttle body from the intake manifold.

NOTE:

Do not disconnect the inlet and outlet hoses of engine coolant.

- 9) Remove the service hole plug.

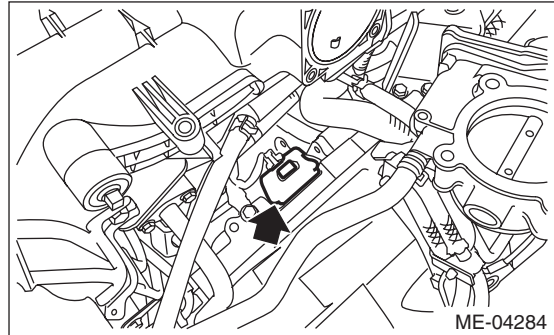

- 10) Remove the crankshaft position sensor.

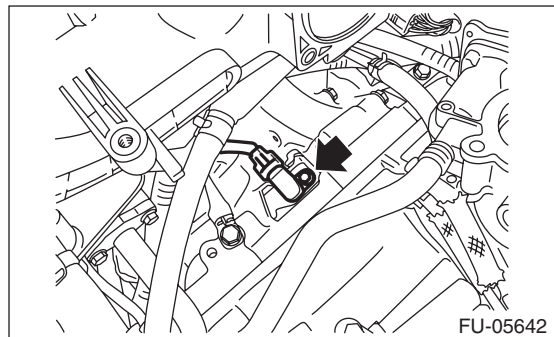

- 11) Disconnect the connector from the crankshaft position sensor.

Crankshaft Position Sensor

FUEL INJECTION (FUEL SYSTEMS)

B: INSTALLATION

Install in the reverse order of removal.

Tightening torque:

6.4 N·m (0.7 kgf-m, 4.7 ft-lb)

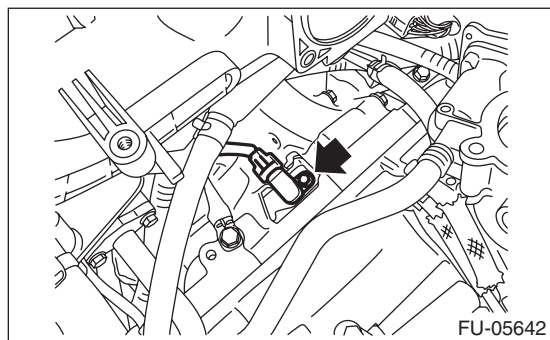

Tightening torque:

Clamp (A), (B)

3 N·m (0.3 kgf-m, 2.2 ft-lb)

Bolt (C)

6.5 N·m (0.7 kgf-m, 4.8 ft-lb)

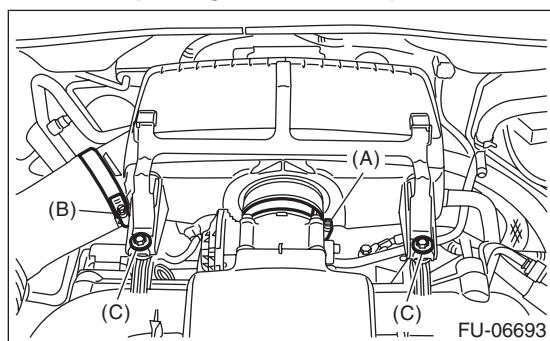

C: INSPECTION

1. CRANKSHAFT POSITION SENSOR (METHOD WITH CIRCUIT TESTER)

Measure the resistance between crankshaft position sensor terminals.

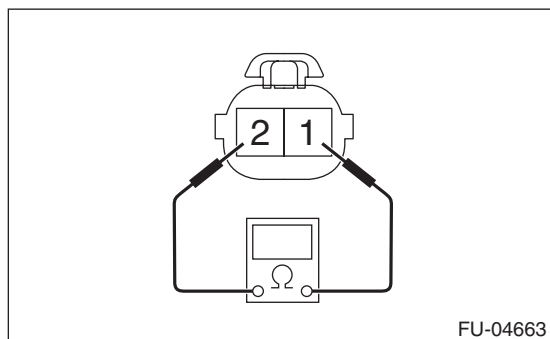

Terminal No.	Standard
1 and 2	1.86±0.186 kΩ

2. CRANKSHAFT POSITION SENSOR (METHOD WITH OSCILLOSCOPE)

- 1) Prepare an oscilloscope.
- 2) Disconnect the ground cable from battery.
- 3) Remove the front pillar lower trim and console side panel lower RH of passenger's side.
- 4) Detach the floor mat of passenger's seat.
- 5) Remove the protect cover.

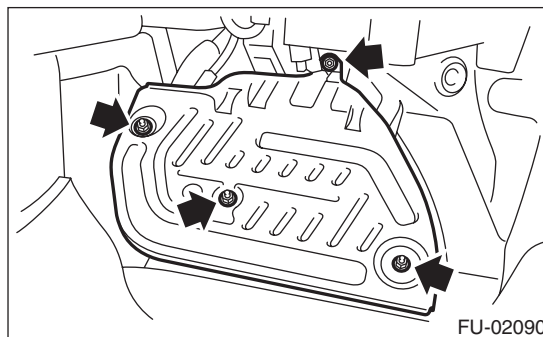

- 6) Remove the ECM from vehicle.

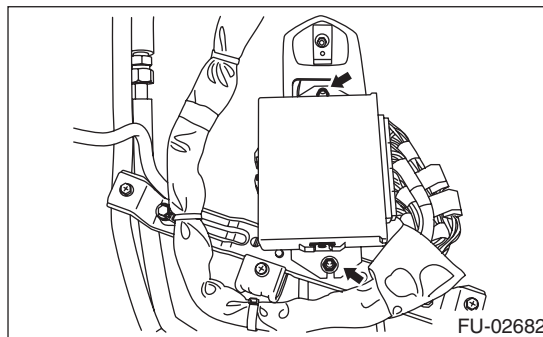

- 7) Connect the probe to ECM connector.

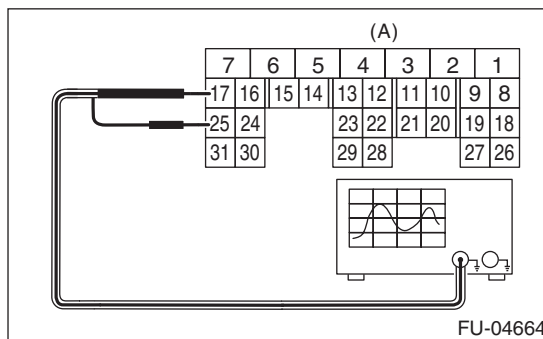

(A) To ECM connector

Terminal No.	Probe
17	+
25	-

- 8) Start the engine and let it idle.

9) Check the pattern is the same as the waveform and voltage shown below.

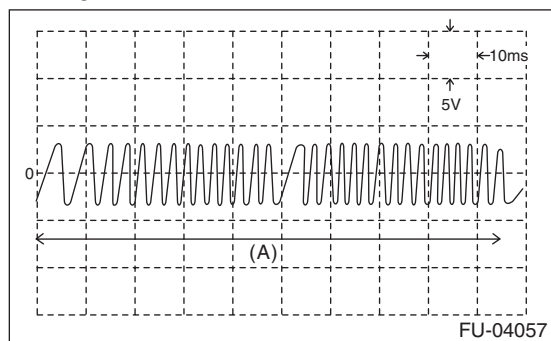

(A) One crankshaft rotation

10) After inspection, install the related parts in the reverse order of removal.

Tightening torque:

7.5 N·m (0.8 kgf-m, 5.5 ft-lb)

3. OTHER INSPECTIONS

Check that the crankshaft position sensor has no deformation, cracks or other damages.