

Camshaft Position Sensor

FUEL INJECTION (FUEL SYSTEMS)

6. Camshaft Position Sensor

A: REMOVAL

1. INTAKE SIDE

- 1) Remove the collector cover.
- 2) Release the fuel pressure. <Ref. to FU(H6DO)-58, RELEASING OF FUEL PRESSURE, PROCEDURE, Fuel.>
- 3) Remove the battery and battery carrier. <Ref. to SC(H6DO)-18, REMOVAL, Battery.>
- 4) Open the fuel filler lid and remove the fuel filler cap.
- 5) Remove the securing clips from the two locations on the fuel pipe protector LH.

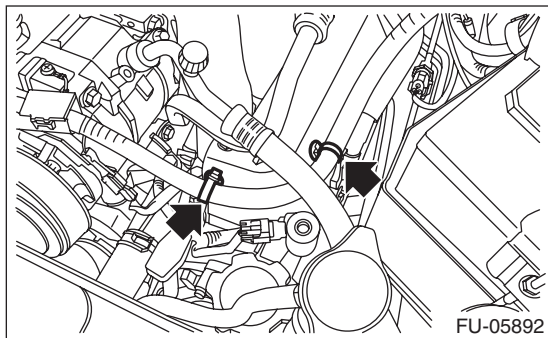

- 6) Disconnect the PCV hose.

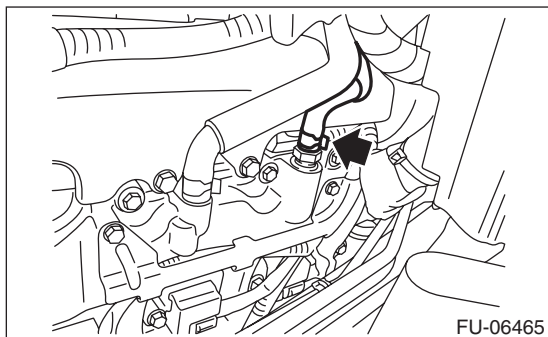

- 7) Remove the fuel pipe protector LH.

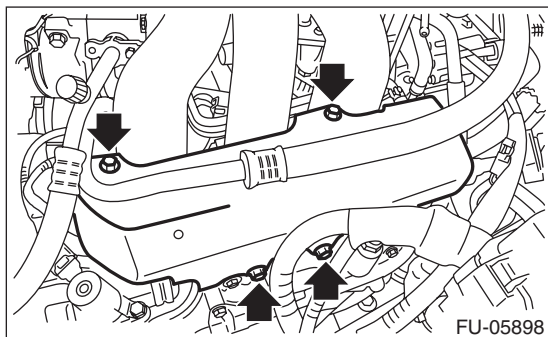

- 8) Disconnect the connectors of the oil temperature sensor, engine coolant temperature sensor and intake oil flow control solenoid valve LH.

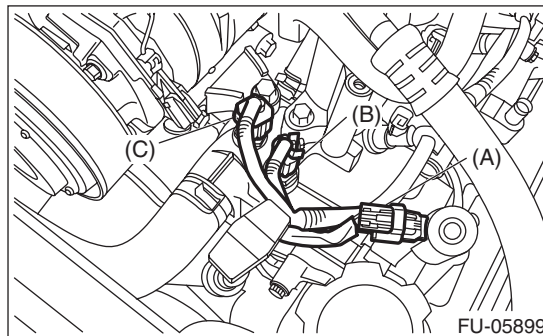

- (A) Intake oil flow control solenoid valve LH
- (B) Oil temperature sensor
- (C) Engine coolant temperature sensor

- 9) Remove the bolts which hold fuel injector pipe LH to cylinder head.

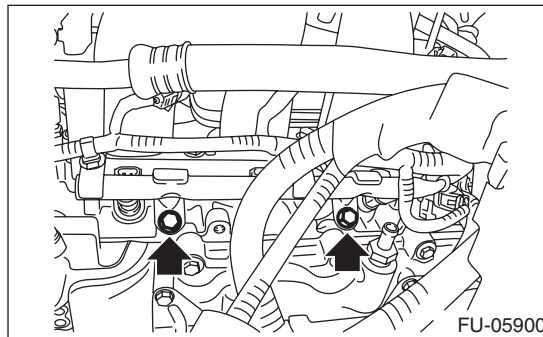

- 10) Slightly raise the fuel injector pipe LH.
- 11) Disconnect the connector from intake camshaft position sensor LH.

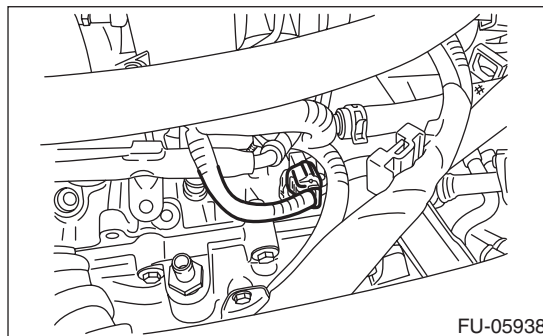

- 12) Remove the intake camshaft position sensor LH.

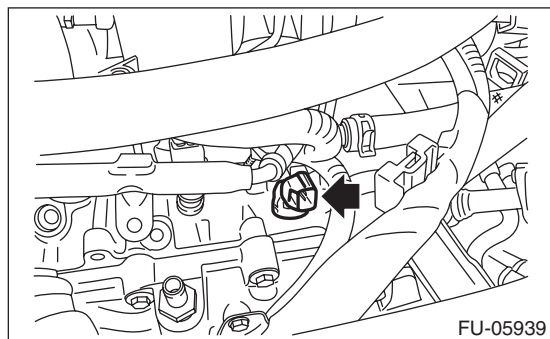

- 13) Remove the intake camshaft position sensor RH in the same procedure as LH side.

2. EXHAUST SIDE

- 1) Disconnect the ground cable from battery.
- 2) Lift up the vehicle.
- 3) Remove the under cover. <Ref. to EI-18, REMOVAL, Front Under Cover.>
- 4) Disconnect the connector from exhaust camshaft position sensor LH.

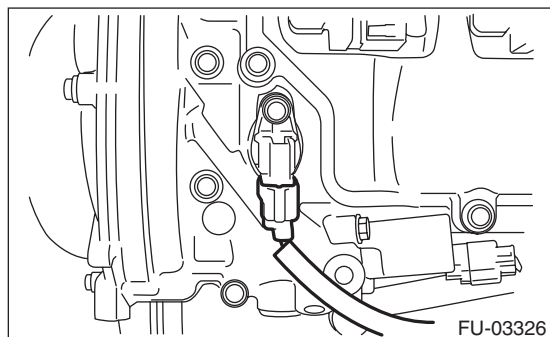

- 5) Remove the exhaust camshaft position sensor LH.

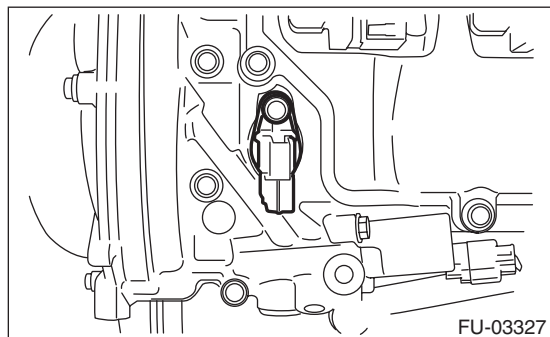

- 6) Remove the exhaust camshaft position sensor RH in the same procedure as LH side.

B: INSTALLATION

1. INTAKE SIDE

Install in the reverse order of removal.

Tightening torque:

Intake camshaft position sensor
6.4 N·m (0.7 kgf-m, 4.7 ft-lb)

Fuel pipe protector
19 N·m (1.9 kgf-m, 14.0 ft-lb)

2. EXHAUST SIDE

Tightening torque:

Exhaust camshaft position sensor
6.4 N·m (0.7 kgf-m, 4.7 ft-lb)

C: INSPECTION

1. CAMSHAFT POSITION SENSOR (METHOD WITH OSCILLOSCOPE)

- 1) Prepare an oscilloscope.
- 2) Disconnect the ground cable from battery.
- 3) Remove the front pillar lower trim and console side panel lower RH of passenger's side.
- 4) Detach the floor mat of passenger's seat.
- 5) Remove the protect cover.

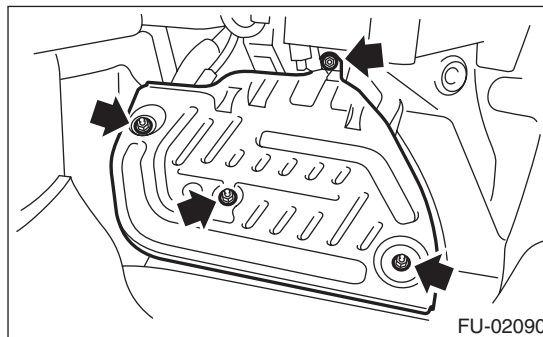

- 6) Remove the ECM from vehicle.

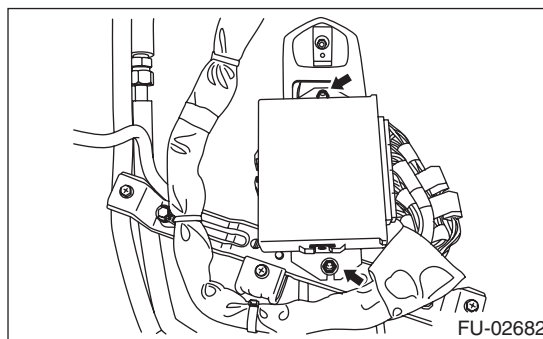

Camshaft Position Sensor

FUEL INJECTION (FUEL SYSTEMS)

7) Connect the probe to ECM connector.

- Intake camshaft position sensor

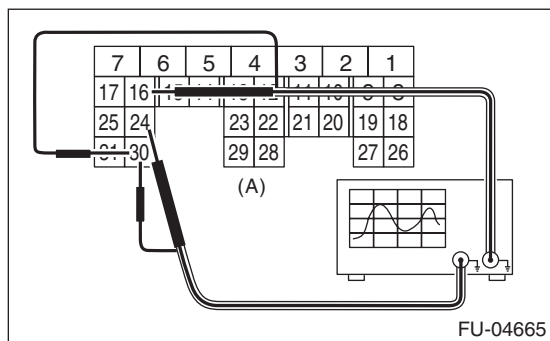

(A) To ECM connector

9) Check the pattern is the same as the waveform and voltage shown below.

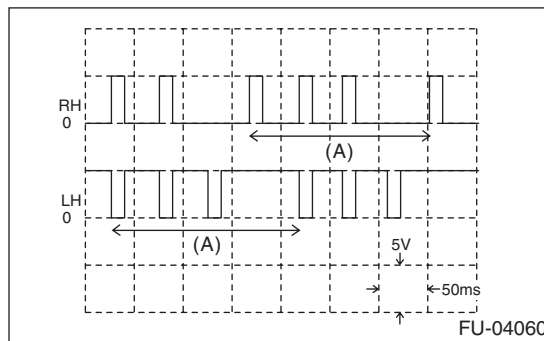

(A) One camshaft rotation

Camshaft position sensor	Terminal No.	Probe
RH	24	+
LH	16	+
RH and LH	30	-

10) After inspection, install the related parts in the reverse order of removal.

Tightening torque:
7.5 N·m (0.8 kgf·m, 5.5 ft·lb)

2. OTHER INSPECTIONS

Check that the camshaft position sensor has no deformation, cracks or other damages.

- Exhaust camshaft position sensor

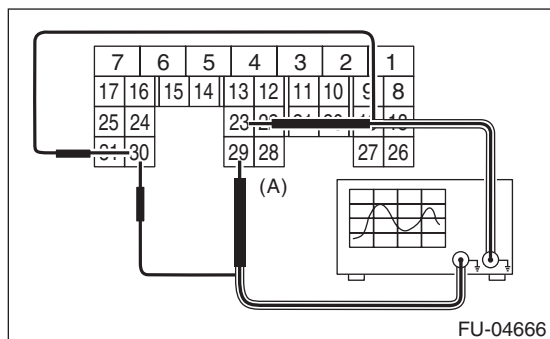

(A) To ECM connector

Camshaft position sensor	Terminal No.	Probe
RH	23	+
LH	29	+
RH and LH	30	-

8) Start the engine and let it idle.