

# Spark Plug

## IGNITION

### 2. Spark Plug

#### A: REMOVAL

##### Spark plug:

<Ref. to IG(H6DO)-2, SPECIFICATION, General Description.>

##### 1. RH SIDE

- 1) Remove the collector cover.
- 2) Disconnect the ground cable from battery.
- 3) Remove the air cleaner case. <Ref. to IN(H6DO)-5, REMOVAL, Air Cleaner Case.>
- 4) Remove the engine harness stay (A).
- 5) Disconnect the connector (B) from ignition coil.

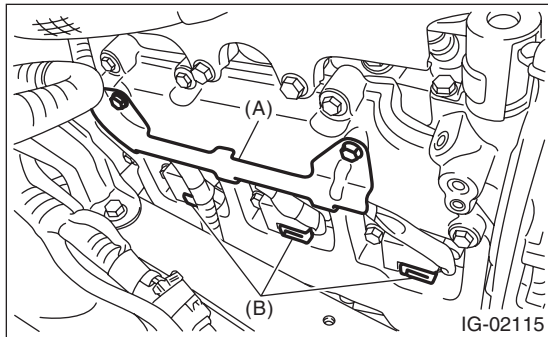

- 6) Remove the ignition coil.

##### NOTE:

Turn the #5 ignition coil to remove it.

- 7) Remove the spark plug with a spark plug socket.

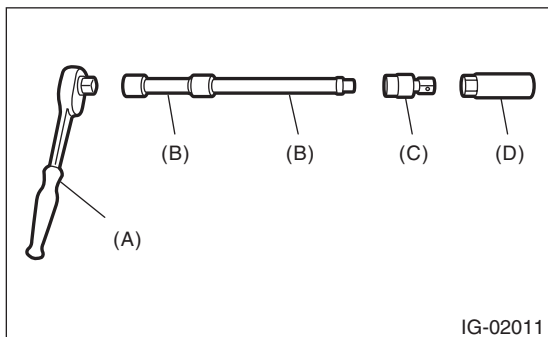
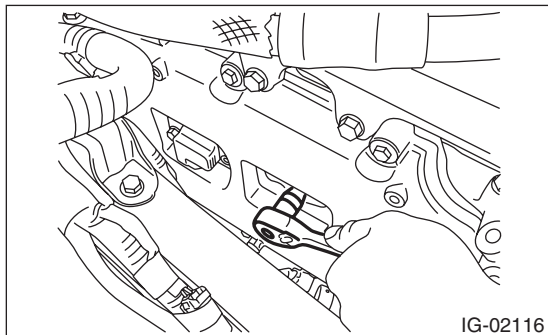

- (A) Ratchet handle
- (B) Extension bar
- (C) Universal joint
- (D) Spark plug socket

##### 2. LH SIDE

- 1) Remove the collector cover.
- 2) Remove the battery and battery carrier. <Ref. to SC(H6DO)-18, REMOVAL, Battery.>
- 3) Remove the engine harness stay (A).
- 4) Disconnect the connector (B) from ignition coil.

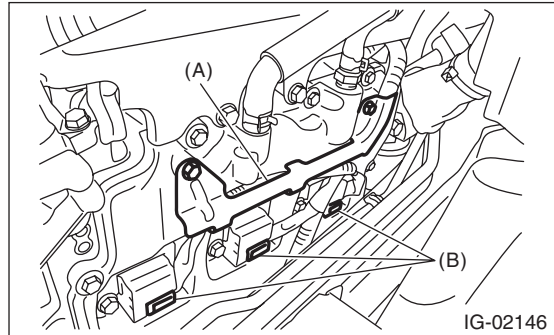

- 5) Remove the ignition coil.

##### NOTE:

Turn the #6 ignition coil to remove it.

- 6) Remove the spark plug with a spark plug socket.

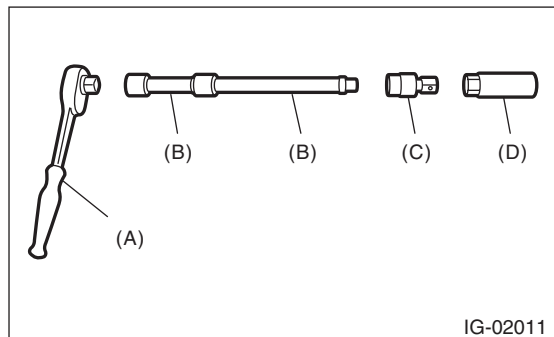
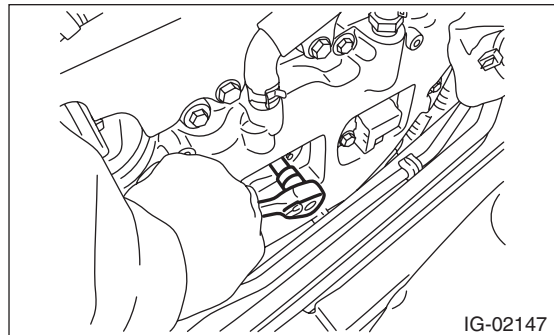

- (A) Ratchet handle
- (B) Extension bar
- (C) Universal joint
- (D) Spark plug socket

## B: INSTALLATION

### 1. RH SIDE

Install in the reverse order of removal.

**Tightening torque:**

**Spark plug**

21 N·m (2.1 kgf-m, 15.5 ft-lb)

**Ignition coil**

16 N·m (1.6 kgf-m, 11.8 ft-lb)

**Engine harness stay**

6.4 N·m (0.7 kgf-m, 4.7 ft-lb)

### 2. LH SIDE

Install in the reverse order of removal.

**Tightening torque:**

**Spark plug**

21 N·m (2.1 kgf-m, 15.5 ft-lb)

**Ignition coil**

16 N·m (1.6 kgf-m, 11.8 ft-lb)

**Engine harness stay**

6.4 N·m (0.7 kgf-m, 4.7 ft-lb)

## C: INSPECTION

1) Check the spark plug for abnormalities. If defective, replace the spark plug.

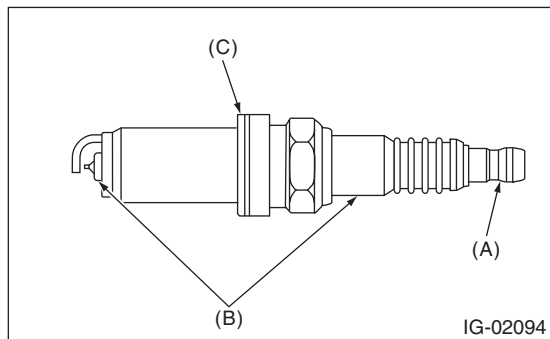

- (A) Terminal damage
- (B) Crack or damage in insulator
- (C) Damaged gasket

2) Check the spark plug electrode and condition of the insulator. If abnormal, check and repair the cause and replace the spark plug.

(1) Normal:

Brown to grayish-tan deposits and slight electrode wear indicate correct spark plug heat range.

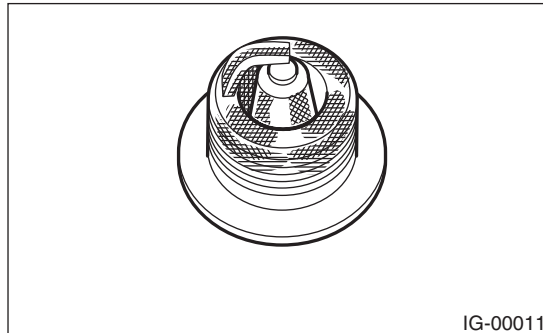

(2) Carbon fouled:

Dry fluffy carbon deposits on the insulator and electrode are mostly caused by slow-speed driving in town, weak ignition, too rich fuel mixture, etc.

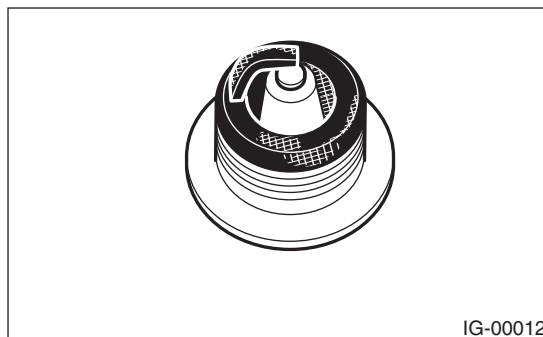

(3) Oil fouled:

Wet black deposits show oil entrance into combustion chamber through worn piston rings or increased clearance between valve guides and valve stems.

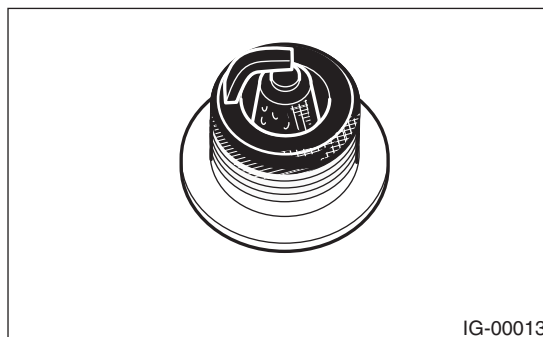

# Spark Plug

## IGNITION

---

### (4) Overheating:

A white or light gray insulator with black or brown spots and bluish burnt electrodes indicate engine overheating, wrong selection of fuel, or loose spark plugs.

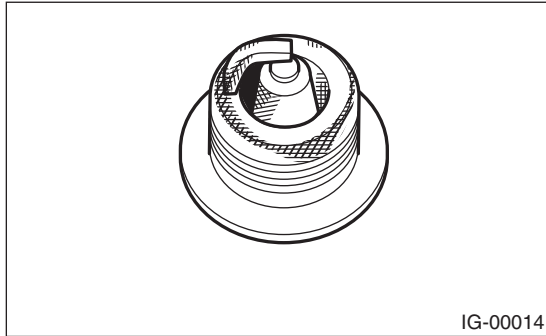

3) Using a nylon brush, etc., clean and remove the carbon or oxide deposits from the spark plug. If deposits are too stubborn, replace the spark plugs. After cleaning the spark plugs, check the spark plug gap "L" using a gap gauge. If it is not within the standard, replace the spark plug.

### NOTE:

- Never use a plug cleaner.
- Do not use a metal brush as it may damage the electrode area.

### **Spark plug gap L:**

#### **Standard**

**1.0 — 1.1 mm (0.039 — 0.043 in)**

