

3. Air Cleaner Case

A: REMOVAL

- 1) Disconnect the ground cable from battery.
- 2) Disconnect the power steering oil pressure hose (suction hose) from the clip on the side of air cleaner case (rear).

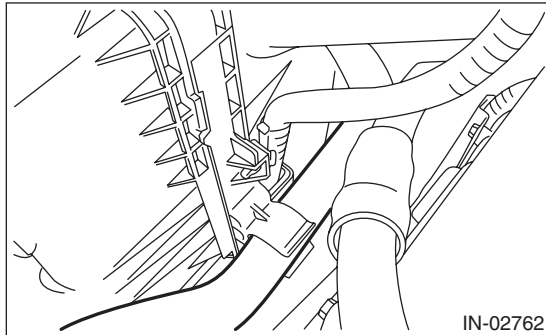

- 3) Disconnect the connectors from the mass air flow and intake air temperature sensor.

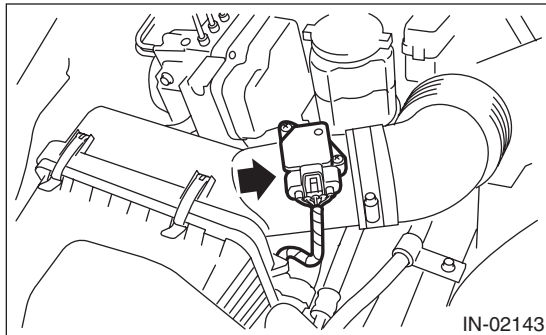

- 4) Loosen the clamp (A) which connects the air cleaner case (rear) to intake duct.
- 5) Remove the clips (B) securing the upper side of the air cleaner case.

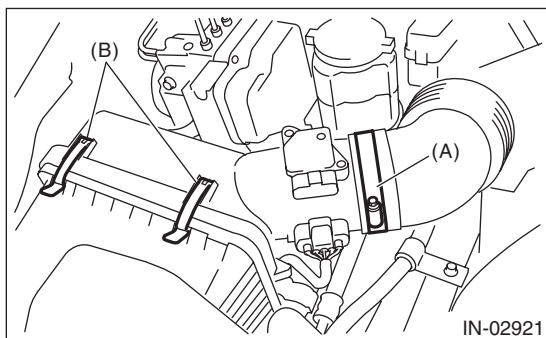

- 6) Remove the air cleaner case (rear) and air cleaner element.

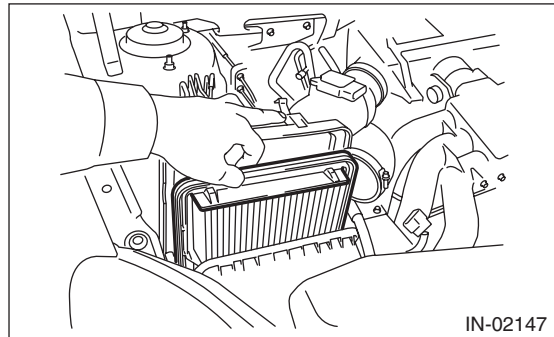

- 7) Remove the air intake duct. <Ref. to IN(H6DO)-8, REMOVAL, Air Intake Duct.>
- 8) Remove the bolts (A) and nut (B) which secure the air cleaner case to body.

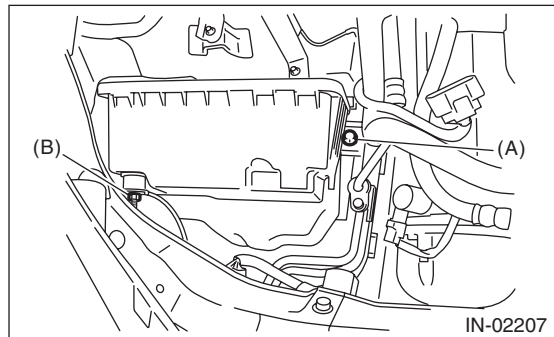

- 9) Remove the air cleaner case (front).

Air Cleaner Case

INTAKE (INDUCTION)

B: INSTALLATION

Install in the reverse order of removal.

Tightening torque:

Bolt (A):

6 N·m (0.6 kgf-m, 4.4 ft-lb)

Nut (B):

7.5 N·m (0.8 kgf-m, 5.5 ft-lb)

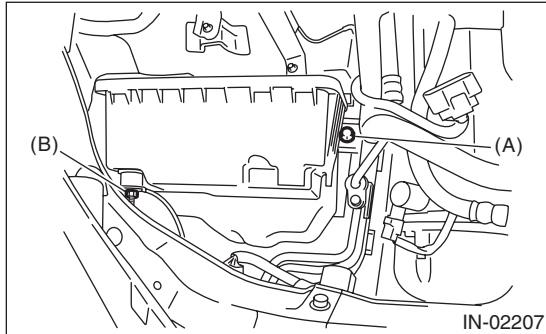

NOTE:

When installing the air cleaner case (rear), align the protrusion of the air cleaner case (rear) to the hole on the air cleaner case (front) to install.

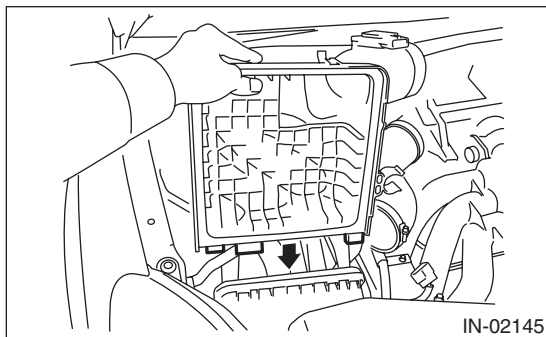

Tightening torque:

3 N·m (0.3 kgf-m, 2.2 ft-lb)

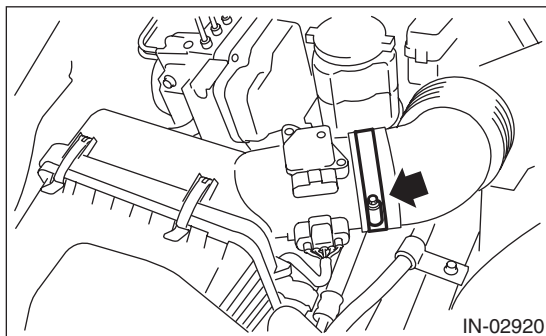

C: INSPECTION

- 1) Check that the air cleaner case has no deformation, cracks or other damages.
- 2) Check the intake boot for cracks, damage or looseness.