

6. Oil Pressure Switch

A: REMOVAL

- 1) Disconnect the ground cable from battery.
- 2) Lift up the vehicle.
- 3) Remove the under cover. <Ref. to EI-18, REMOVAL, Front Under Cover.>
- 4) Drain the engine oil. <Ref. to LU(H6DO)-10, REPLACEMENT, Engine Oil.>
- 5) Disconnect the terminal from oil pressure switch.

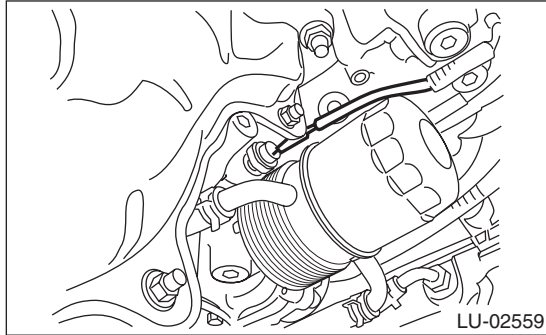

- 6) Remove the oil pressure switch.

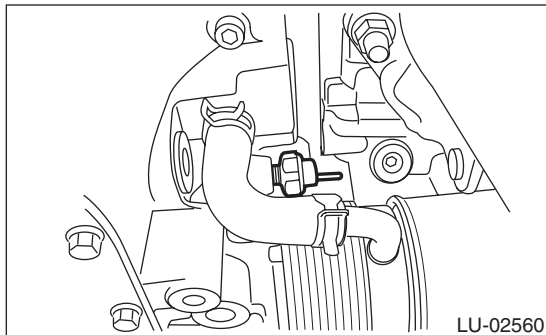

B: INSTALLATION

- 1) Apply liquid gasket to the oil pressure switch threads.

Liquid gasket:

THREE BOND 1324 (Part No. 004403042) or equivalent

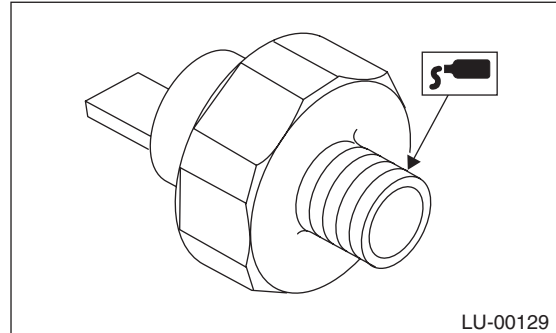

- 2) Install the oil pressure switch.

Tightening torque:

25 N·m (2.5 kgf-m, 18.4 ft-lb)

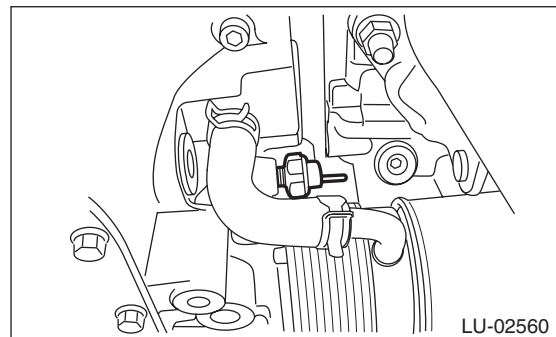

- 3) Connect the terminal of the oil pressure switch.

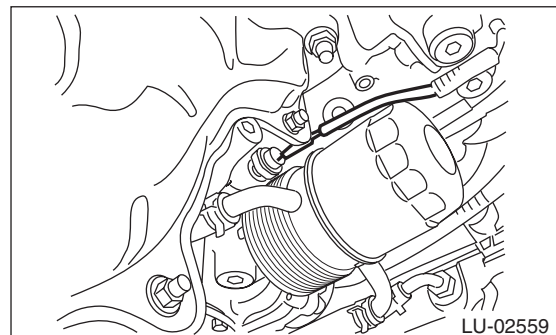

- 4) Install the under cover. <Ref. to EI-18, INSTALLATION, Front Under Cover.>
- 5) Refill the engine oil. <Ref. to LU(H6DO)-10, REPLACEMENT, Engine Oil.>
- 6) Check the engine oil level. <Ref. to LU(H6DO)-10, INSPECTION, Engine Oil.>

C: INSPECTION

- 1) Check that the oil pressure switch does not have deformation, cracks or damage.
- 2) Check that there are no oil leaks or oil oozing from the oil pressure switch installation portion.