

Timing Chain Assembly

MECHANICAL

15. Timing Chain Assembly

A: LOCATION

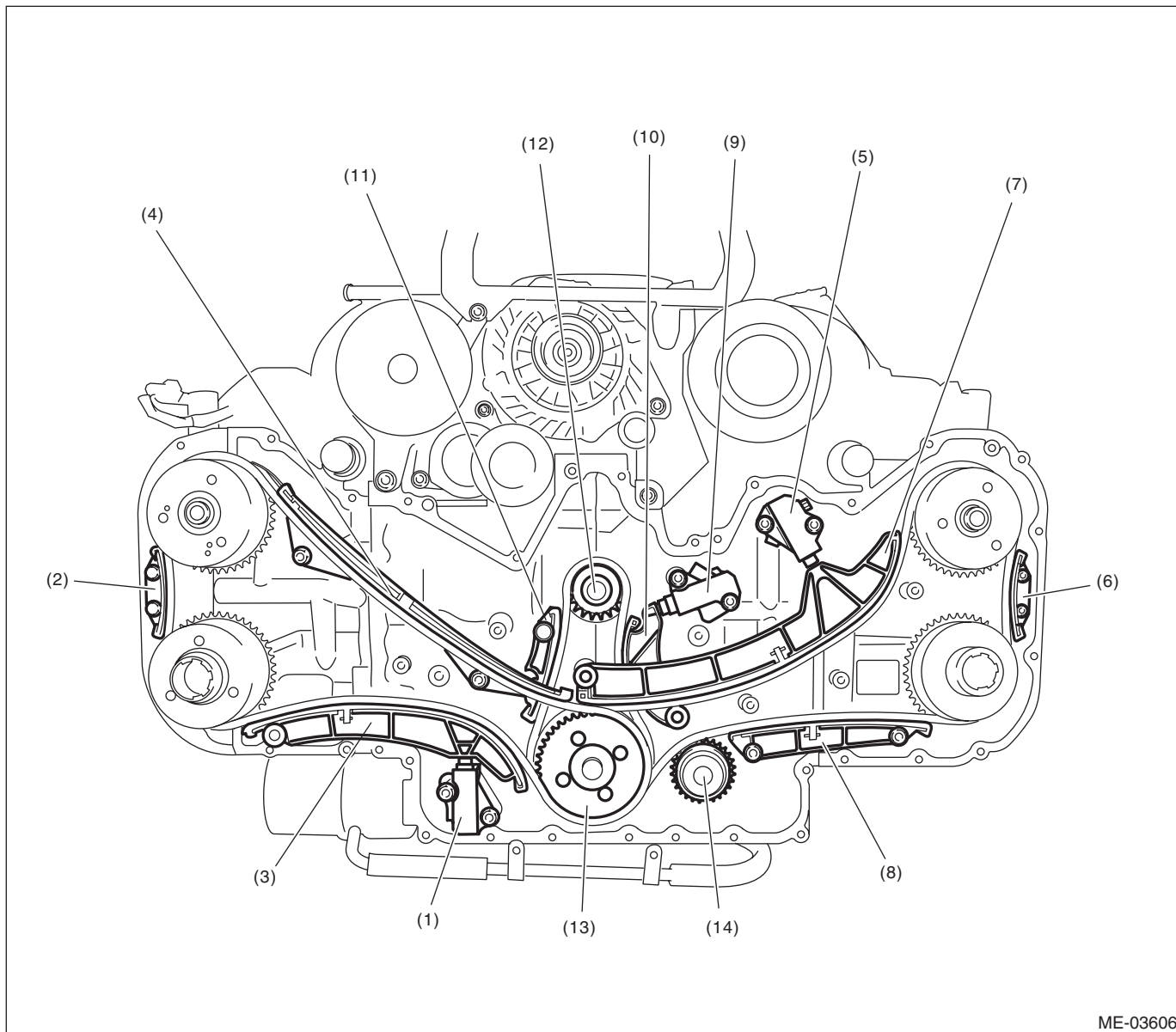

- | | | |
|------------------------------------|------------------------------------|--------------------------|
| (1) Chain tensioner (RH) | (6) Chain guide (LH: between cams) | (11) Chain guide (main) |
| (2) Chain guide (RH: between cams) | (7) Chain tensioner lever (LH) | (12) Crank sprocket |
| (3) Chain tensioner lever (RH) | (8) Chain guide (LH) | (13) Idler sprocket |
| (4) Chain guide (RH) | (9) Chain tensioner (main) | (14) Water pump sprocket |
| (5) Chain tensioner (LH) | (10) Chain tensioner lever (main) | |

B: REMOVAL

NOTE:

To avoid mixing the timing chain component parts, separate each part after their removal.

- 1) Drain the engine oil. <Ref. to LU(H6DO)-10, REPLACEMENT, Engine Oil.>
- 2) Remove the radiator. <Ref. to CO(H6DO)-17, REMOVAL, Radiator.>
- 3) Remove the V-belts. <Ref. to ME(H6DO)-46, REMOVAL, V-belt.>
- 4) Remove the crank pulley. <Ref. to ME(H6DO)-47, REMOVAL, Crank Pulley.>
- 5) Remove the chain cover. <Ref. to ME(H6DO)-48, REMOVAL, Chain Cover.>
- 6) Remove the chain tensioner (RH).

NOTE:

During removal of chain tensioner (RH) from chain tensioner lever (RH), press the plunger by hand to prevent it from popping out.

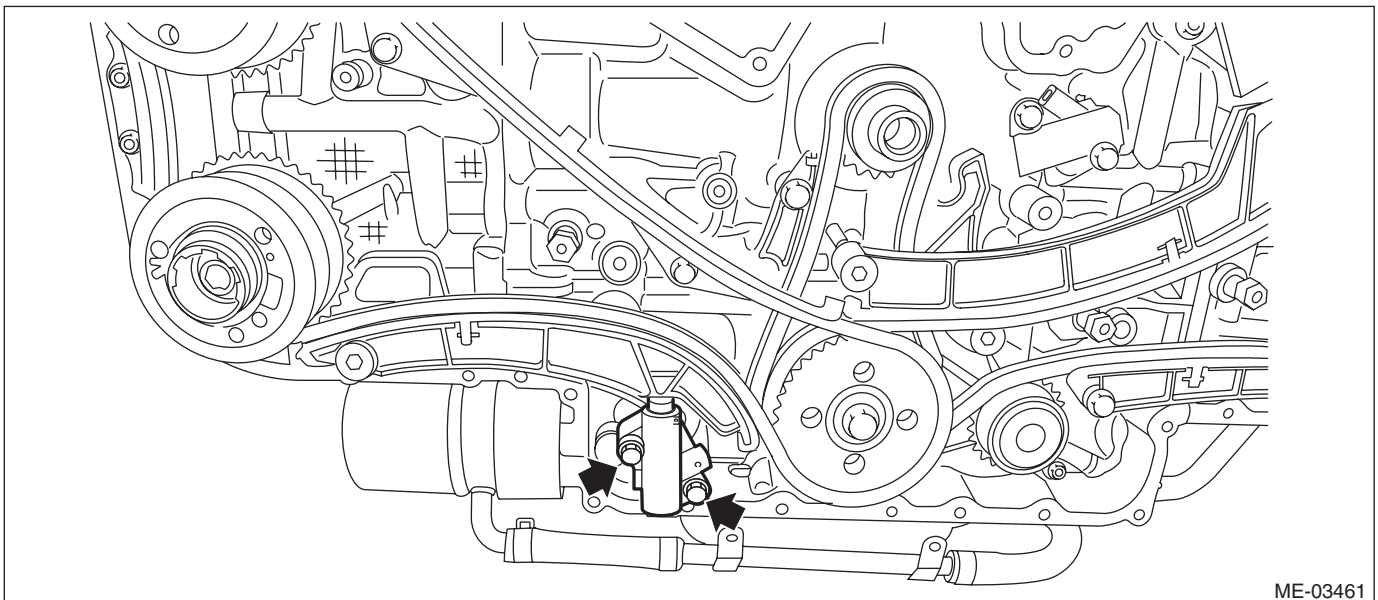

- 7) Remove the chain guide (RH: between cams).

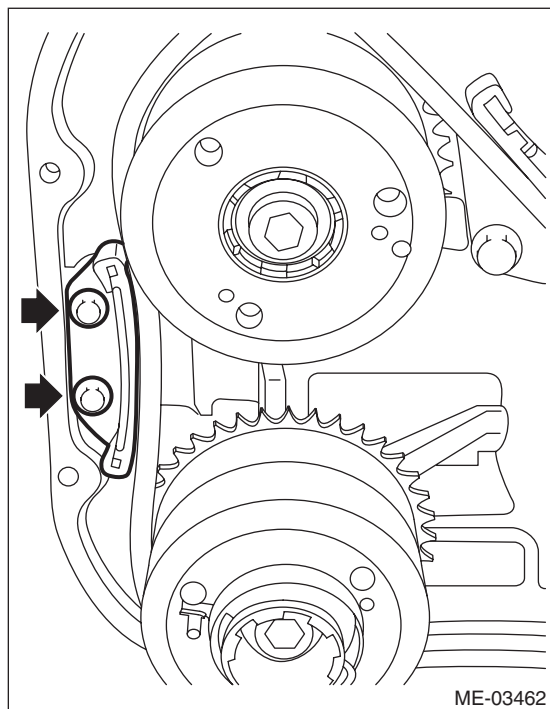

Timing Chain Assembly

MECHANICAL

8) Remove the chain tensioner lever (RH).

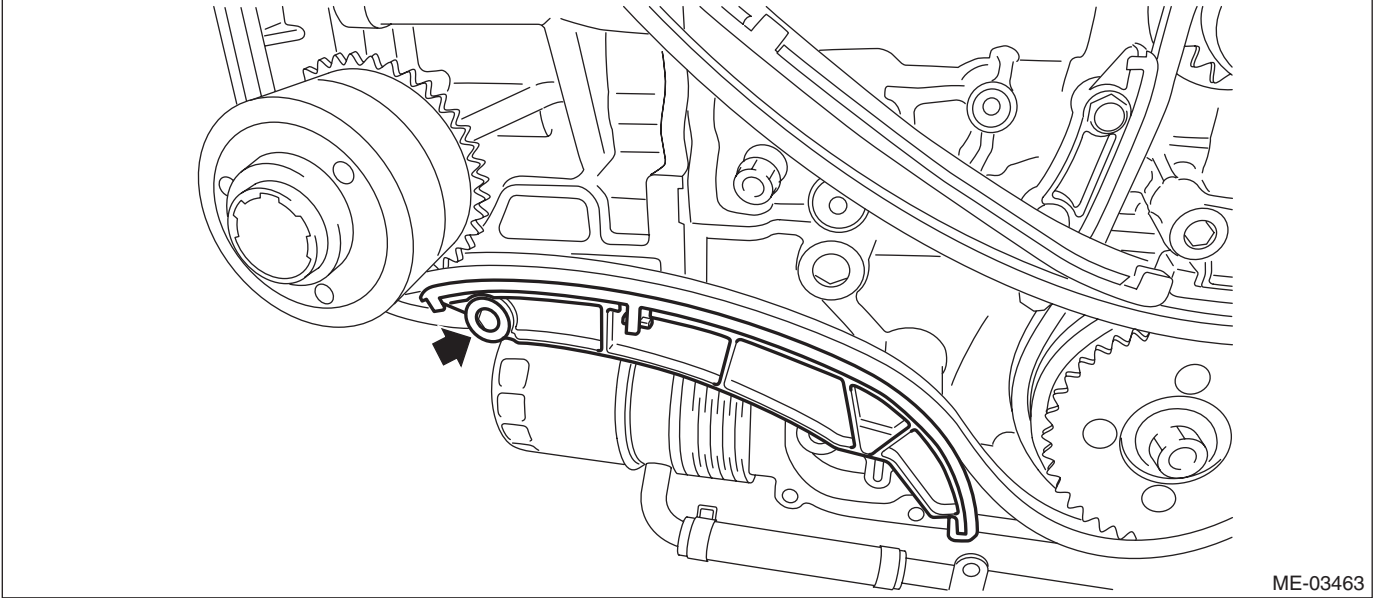

ME-03463

9) Remove the chain guide (RH).

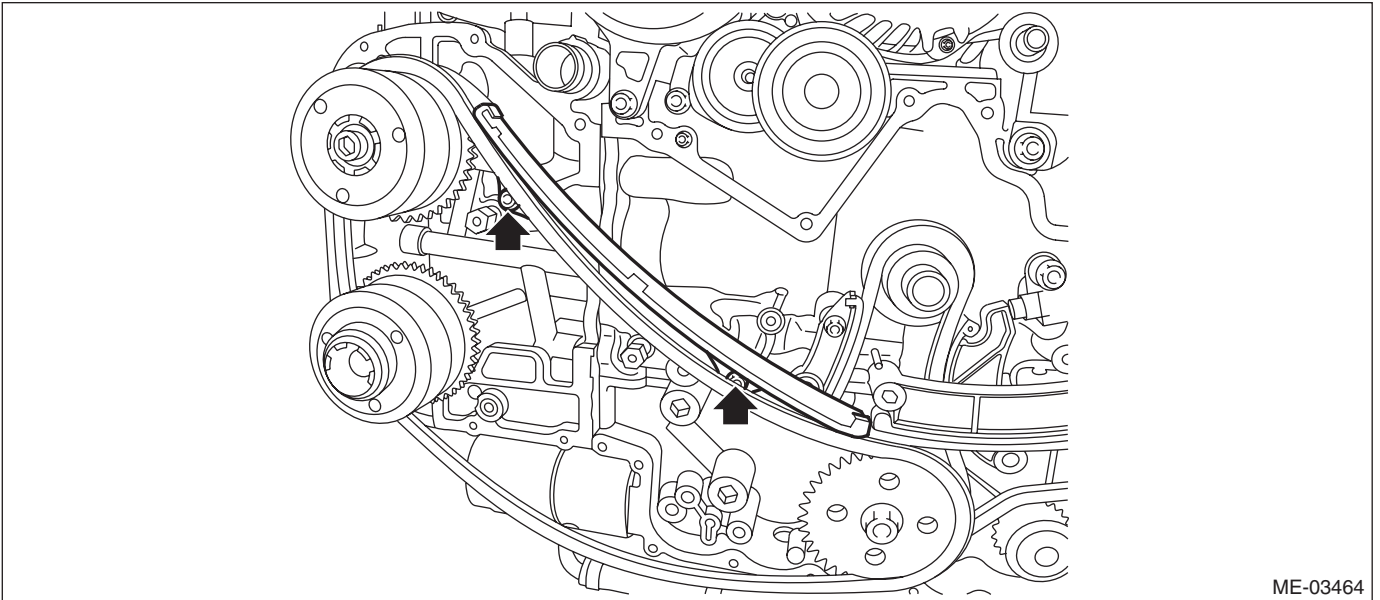

ME-03464

10) Remove the timing chain (RH).

Timing Chain Assembly

MECHANICAL

11) Remove the chain tensioner (LH).

NOTE:

During removal of chain tensioner (LH) from chain tensioner lever (LH), press the plunger by hand to prevent it from popping out.

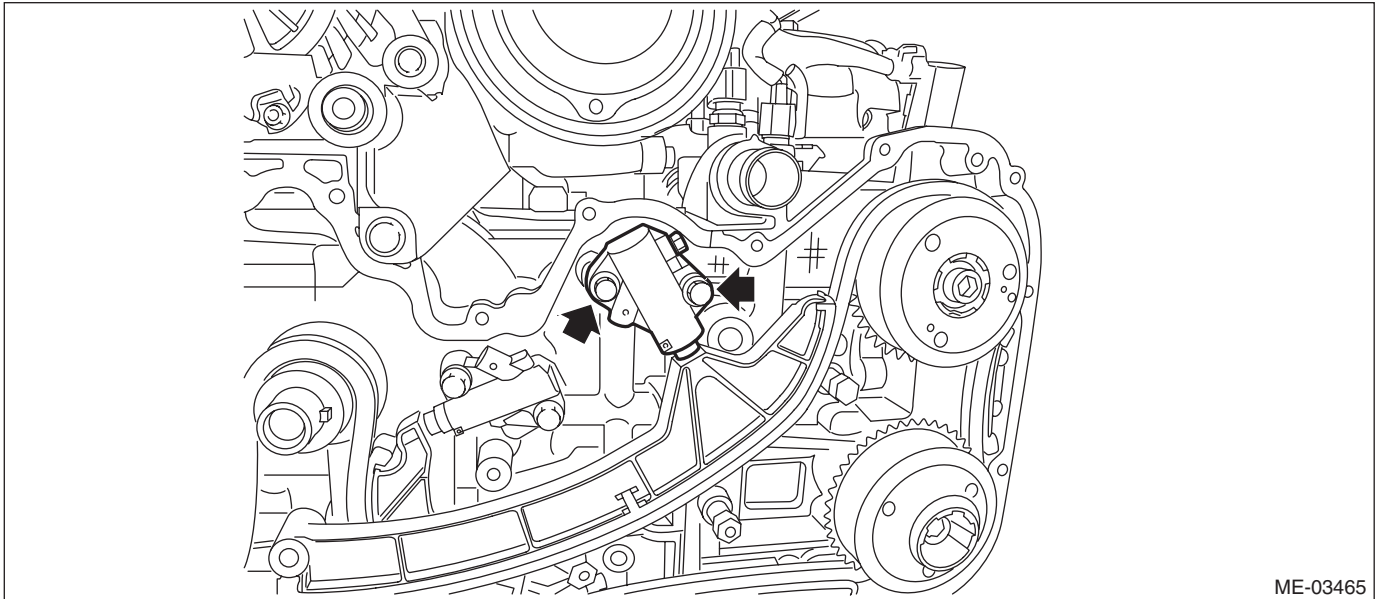

12) Remove the chain guide (LH: between cams).

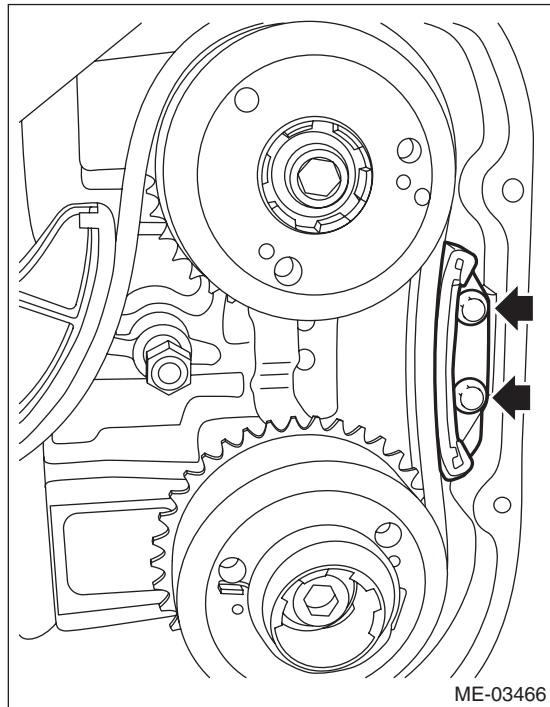

Timing Chain Assembly

MECHANICAL

13) Remove the chain tensioner lever (LH).

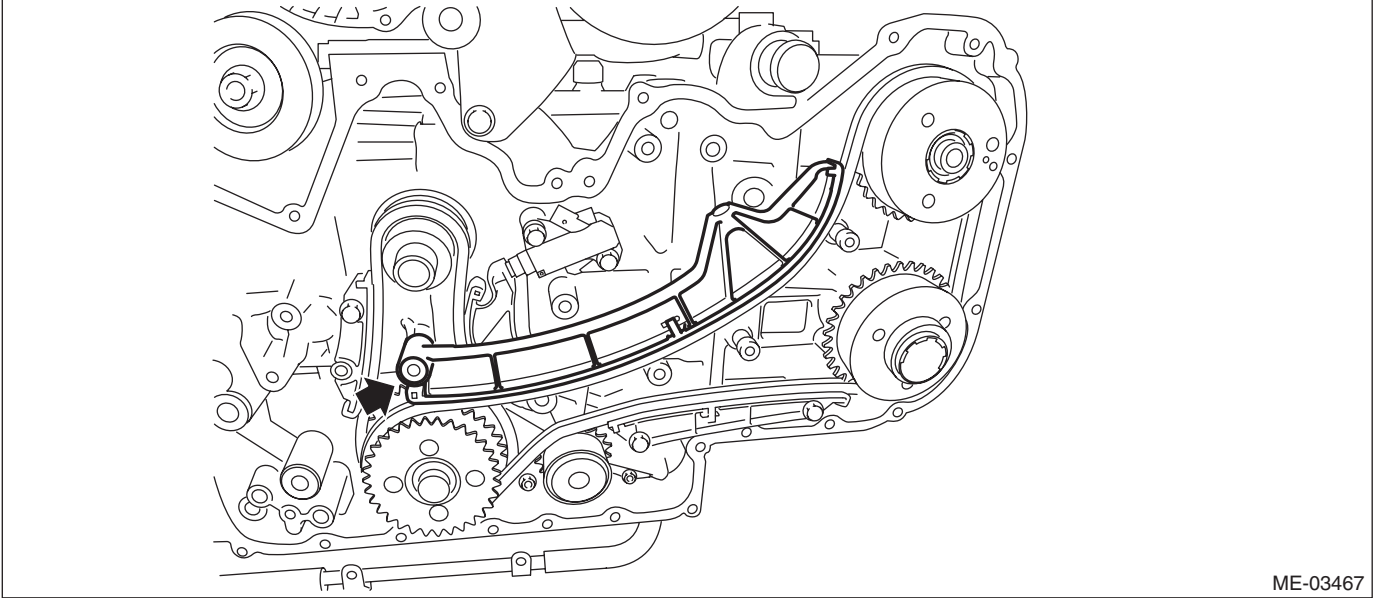

14) Remove the chain guide (LH).

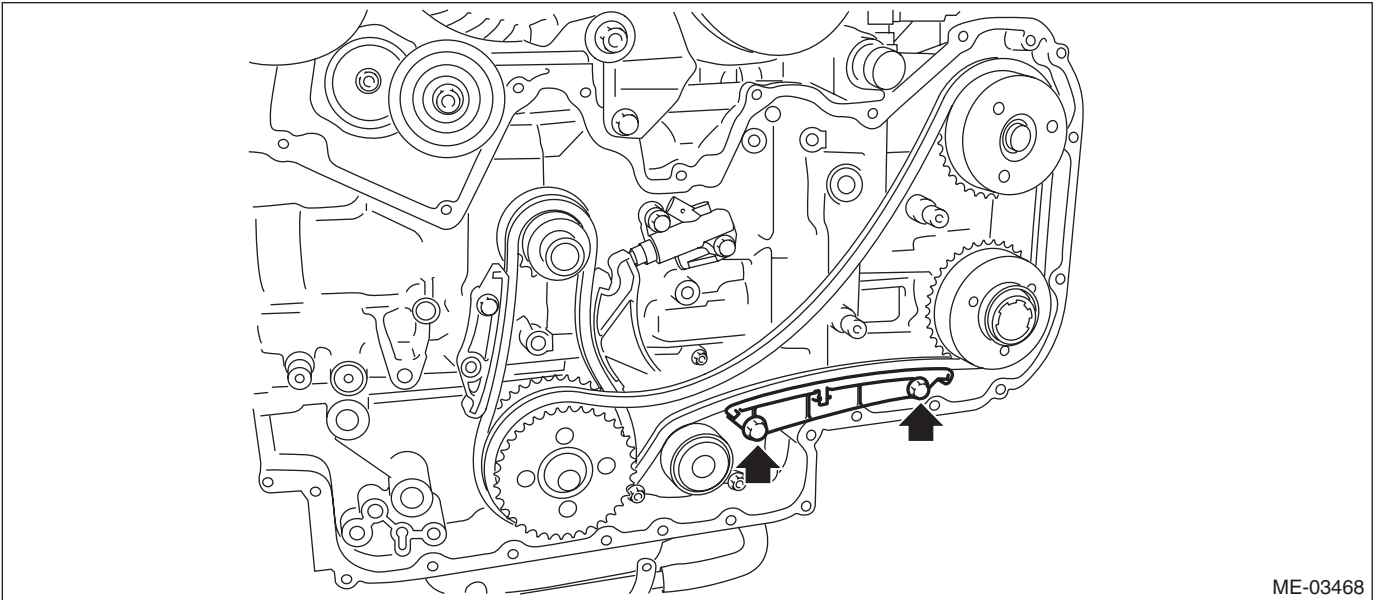

15) Remove the timing chain (LH).

Timing Chain Assembly

MECHANICAL

16) Remove the chain tensioner (main).

NOTE:

During removal of chain tensioner (main) from chain tensioner lever (main), press the plunger by hand to prevent it from popping out.

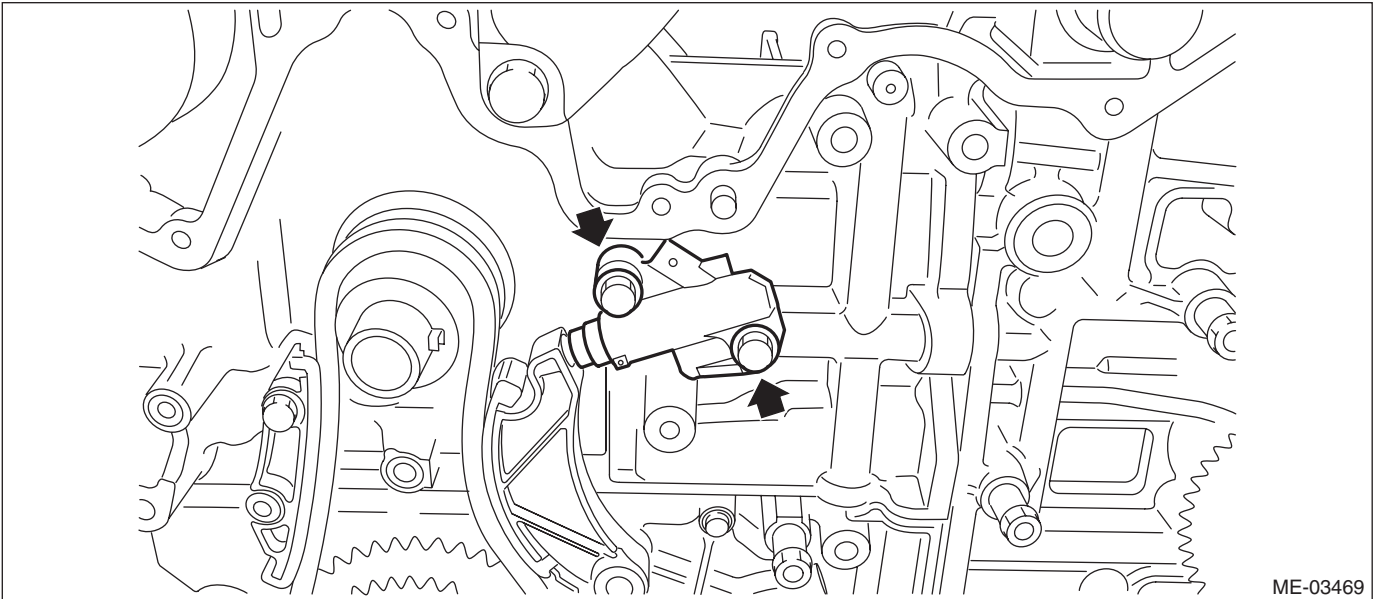

17) Remove the chain guide (main).

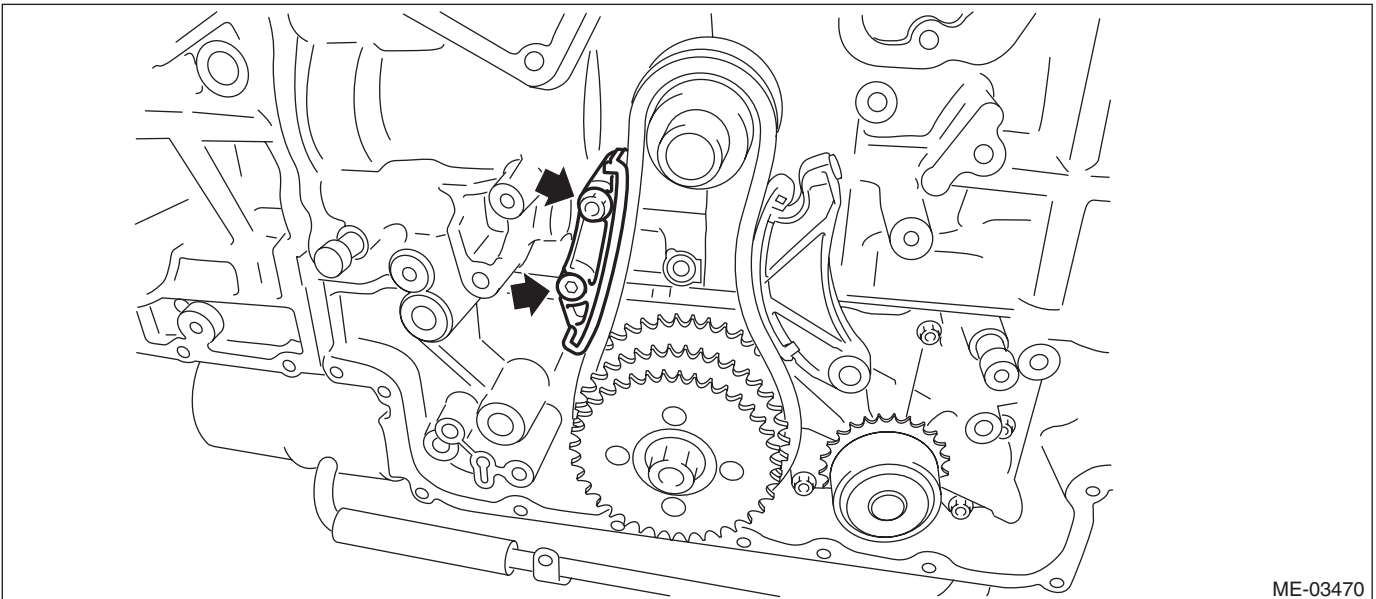

Timing Chain Assembly

MECHANICAL

18) Remove the chain tensioner lever (main).

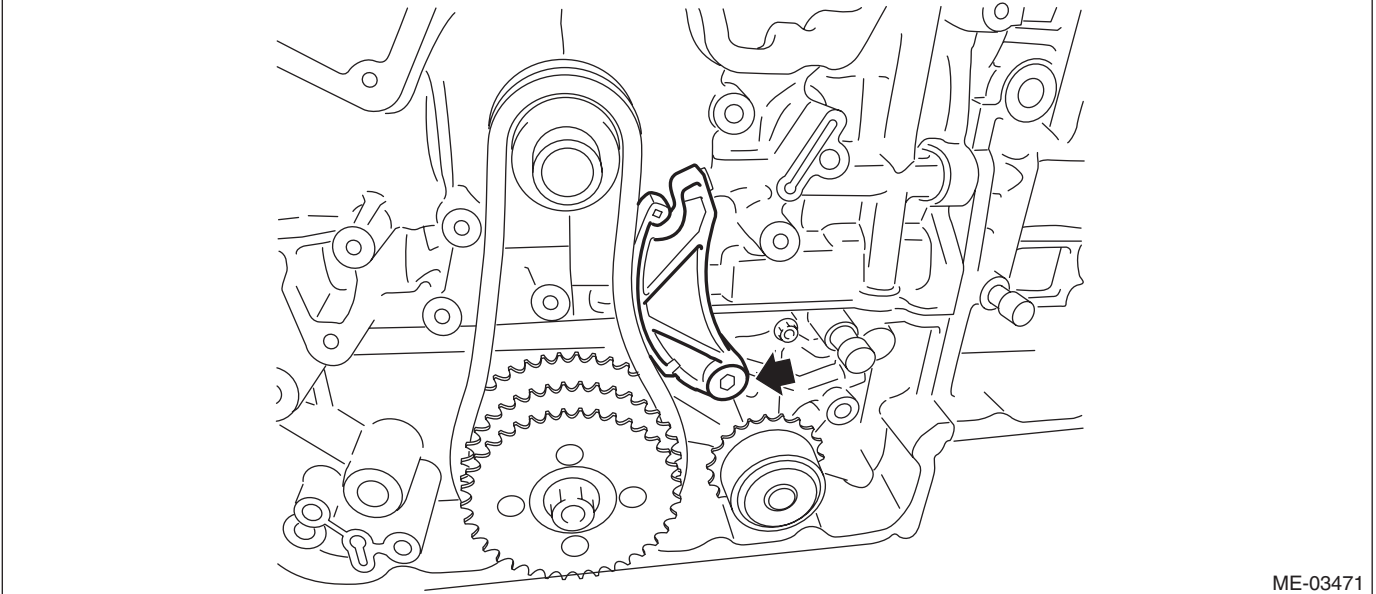

ME-03471

19) Use the ST to lock the idler sprocket, and loosen the idler sprocket bolt.

ST1 18355AA000 PULLEY WRENCH

ST2 18334AA000 PULLEY WRENCH PIN SET

20) Remove the idler sprocket, and then remove the idler sprocket and timing chain (main).

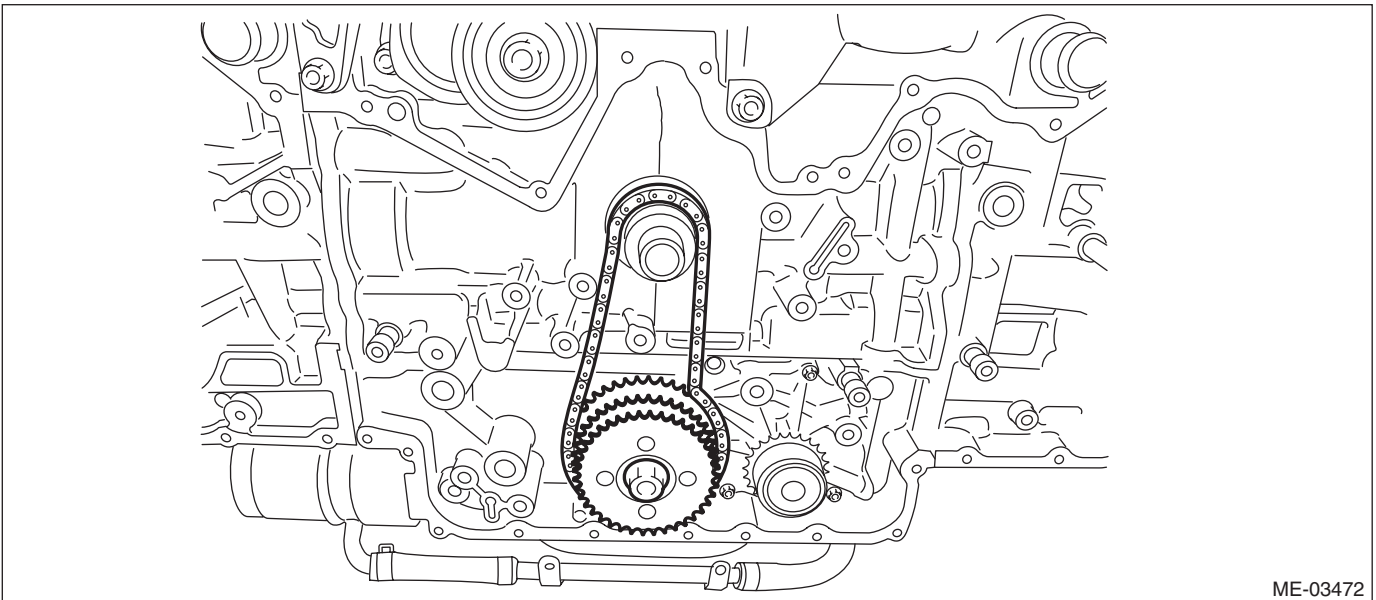

ME-03472

C: INSTALLATION

NOTE:

- Be careful that the foreign matter is not into or onto assembled component during installation.
- Apply engine oil to all component parts of the timing chain.

1) Prepare to attach the chain tensioner.

(1) Insert the screw, spring pin and plunger into the tensioner body.

(2) As shown in the figure, turn the rubber mat counterclockwise while holding the chain tensioner from above by hand.

NOTE:

Degrease the contact surface between the plunger head and rubber mat, so that they do not slip.

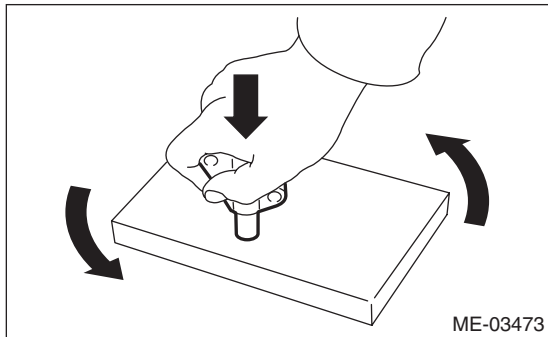

(3) Insert the stopper pin into the hole on the chain tensioner body.

2) Align the position of oil pump shaft knock pin to six o'clock position as shown in the figure.

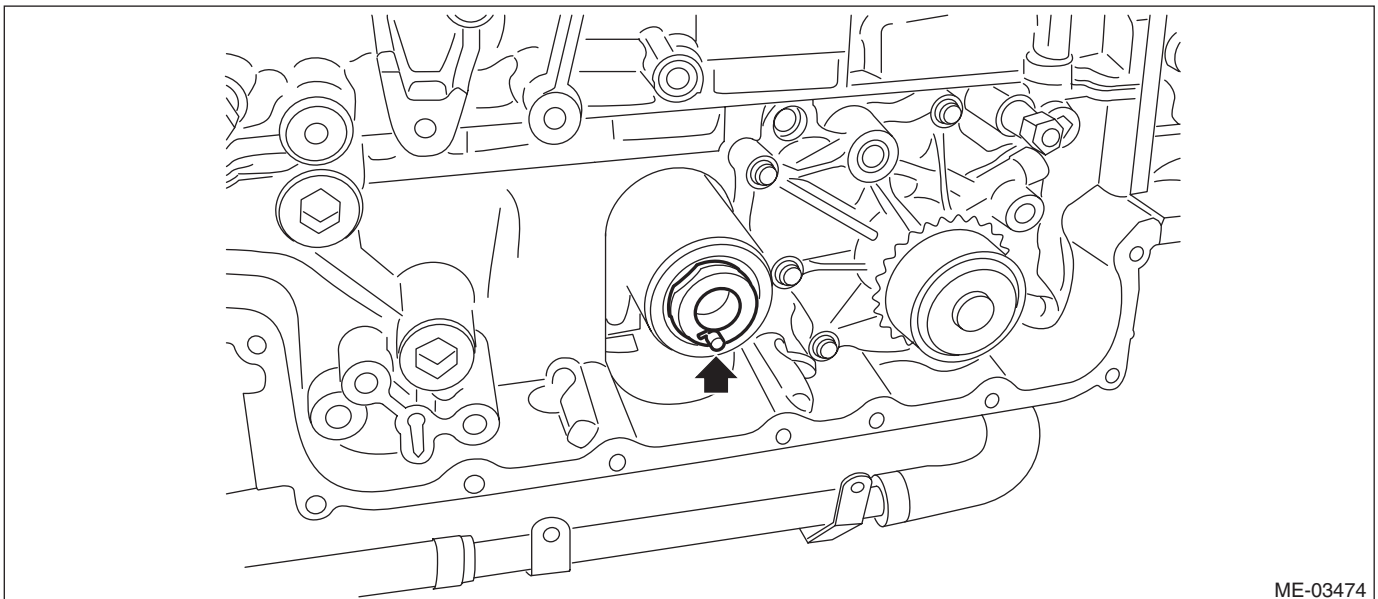

Timing Chain Assembly

MECHANICAL

3) Using ST, align the "Top mark" on crank sprocket to nine o'clock position as shown in the figure.
ST 18252AA000 CRANKSHAFT SOCKET

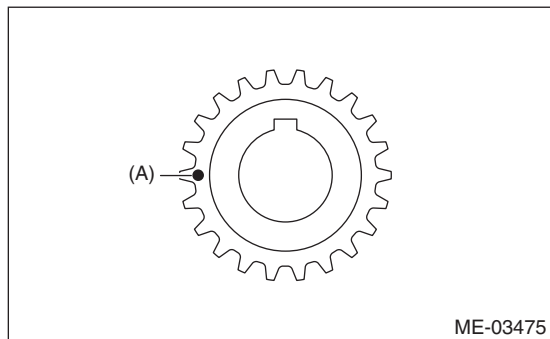

(A) Top mark

4) Align the intake cam sprocket to twelve o'clock position as shown in the figure.
ST 499977500 CAM SPROCKET WRENCH

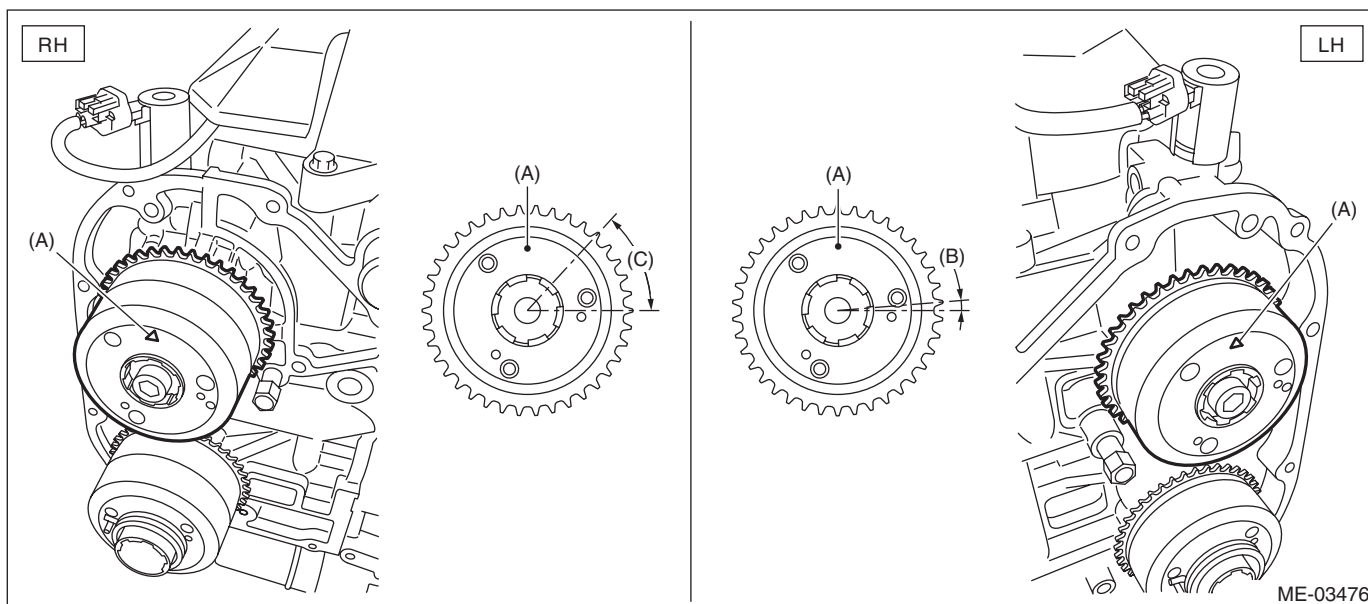

(A) Align the marking (top mark) to twelve o'clock position.

(B) 6°

(C) 47°

Timing Chain Assembly

MECHANICAL

5) Align the exhaust cam sprocket to twelve o'clock position as shown in the figure.

ST 499977500 CAM SPROCKET WRENCH

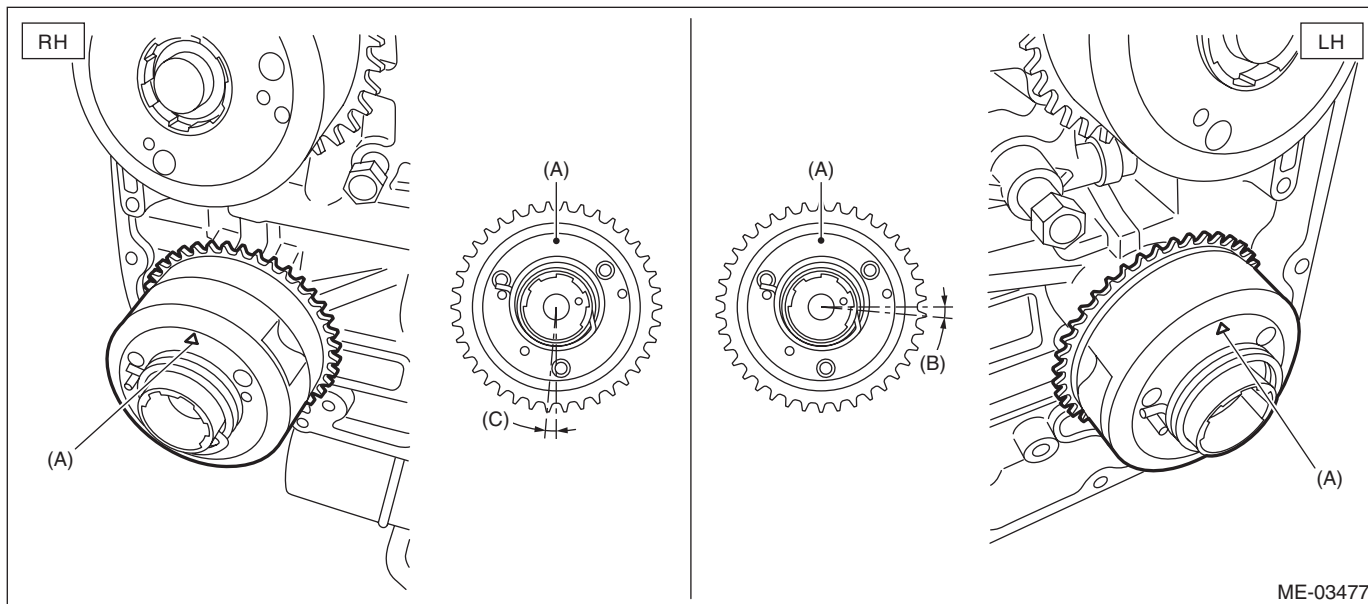

(A) Align the marking (top mark) to twelve o'clock position.

(B) 5.5°

(C) 3.5°

6) Using ST, align the "Top mark" on crank sprocket to twelve o'clock position as shown in the figure.

NOTE:

- The #1 piston is positioned at TDC.
- Do not rotate the crankshaft and cam sprocket before completing timing chain installation.
- Crank sprocket key is located at three o'clock position.

ST 18252AA000 CRANKSHAFT SOCKET

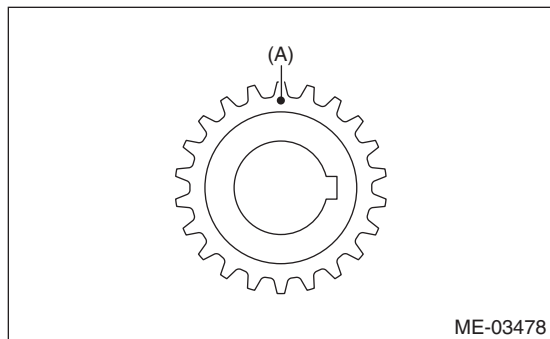

(A) Top mark

Timing Chain Assembly

MECHANICAL

7) Install the chain guide (main).

Tightening torque:

16 N·m (1.6 kgf·m, 11.8 ft·lb)

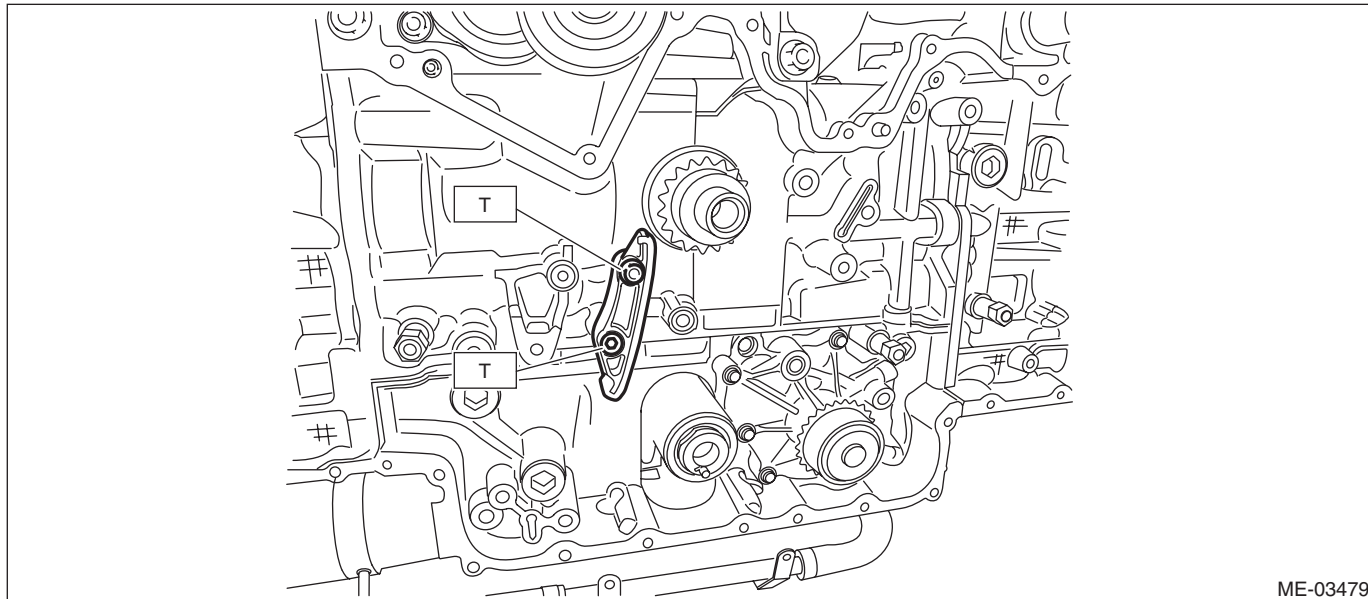

8) Install the idler sprocket and timing chain (main).

- (1) Match the timing chain mark (gold) to the timing mark position of the idler sprocket.
- (2) Align the idler sprocket timing mark at six o'clock position, and install the idler sprocket and timing chain.
- (3) Make sure that the timing chain mark (gold) is located at twelve o'clock position on the crank sprocket.
- (4) Use the ST1 and ST2 to lock the idler sprocket, and install the idler sprocket bolt.

ST1 18355AA000 PULLEY WRENCH

ST2 18334AA000 PULLEY WRENCH PIN SET

Tightening torque:

120 N·m (12.2 kgf·m, 88.5 ft·lb)

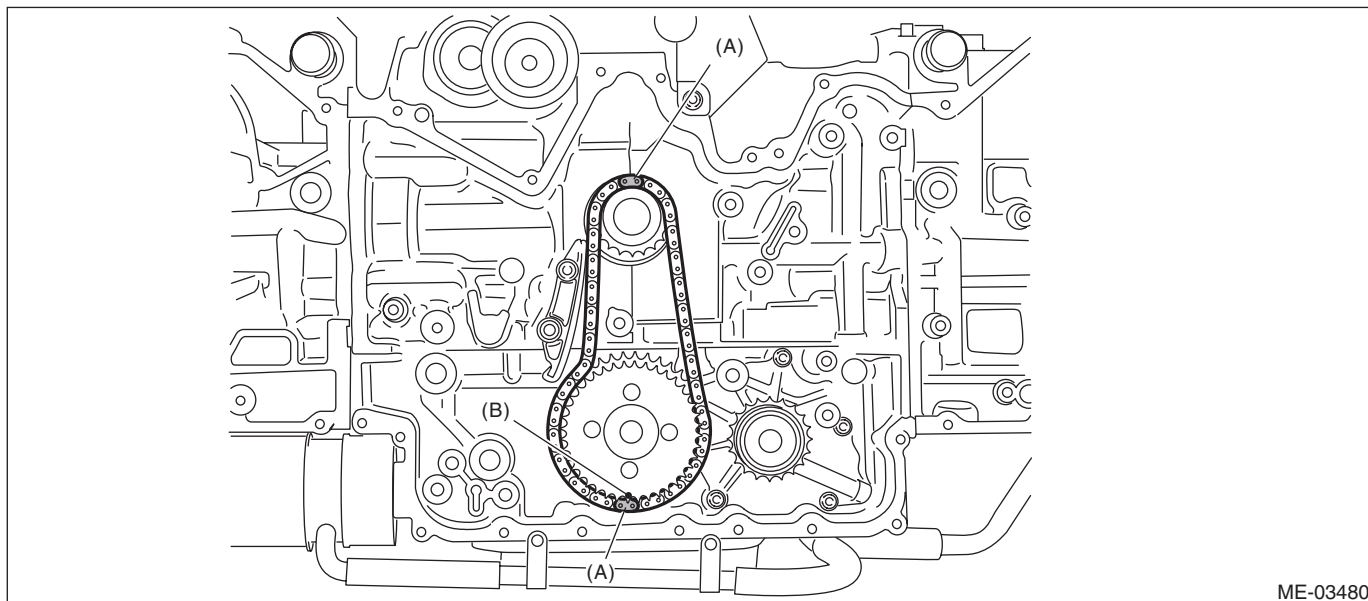

(A) Gold

(B) Timing mark

Timing Chain Assembly

MECHANICAL

9) Install the chain tensioner lever (main).

Tightening torque:

16 N·m (1.6 kgf·m, 11.8 ft·lb)

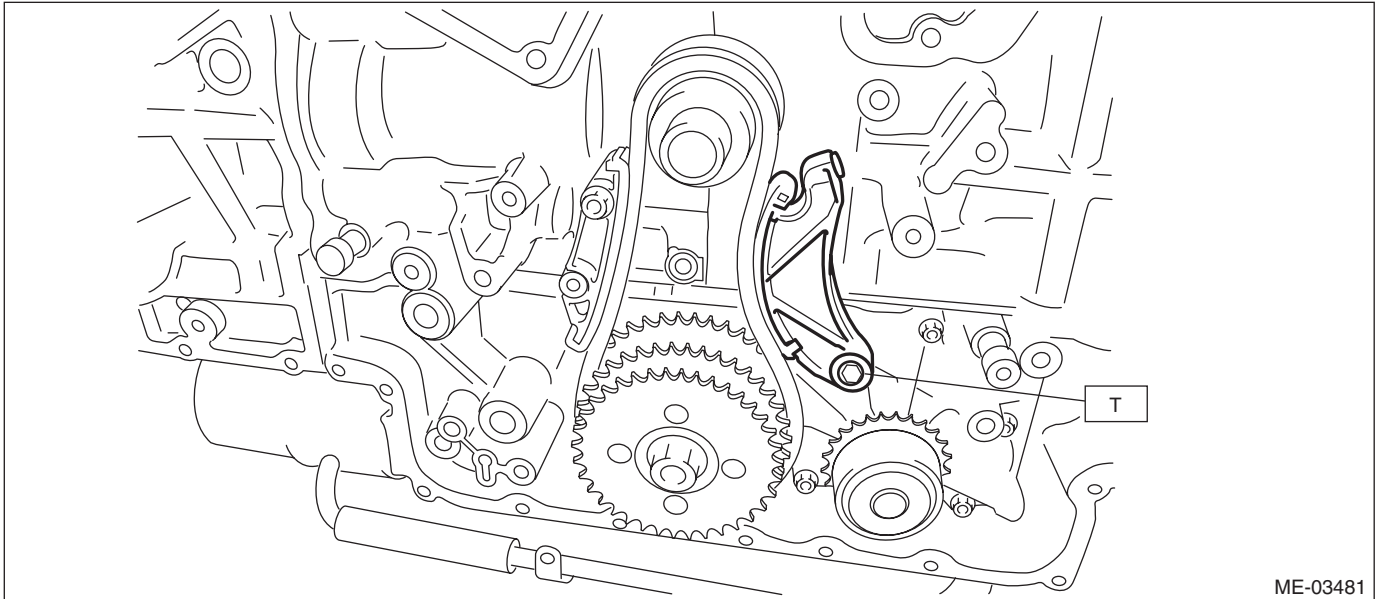

ME-03481

10) Install the chain tensioner (main) and pull out the stopper pin.

NOTE:

The timing chain (main) line will be complete.

Tightening torque:

16 N·m (1.6 kgf·m, 11.8 ft·lb)

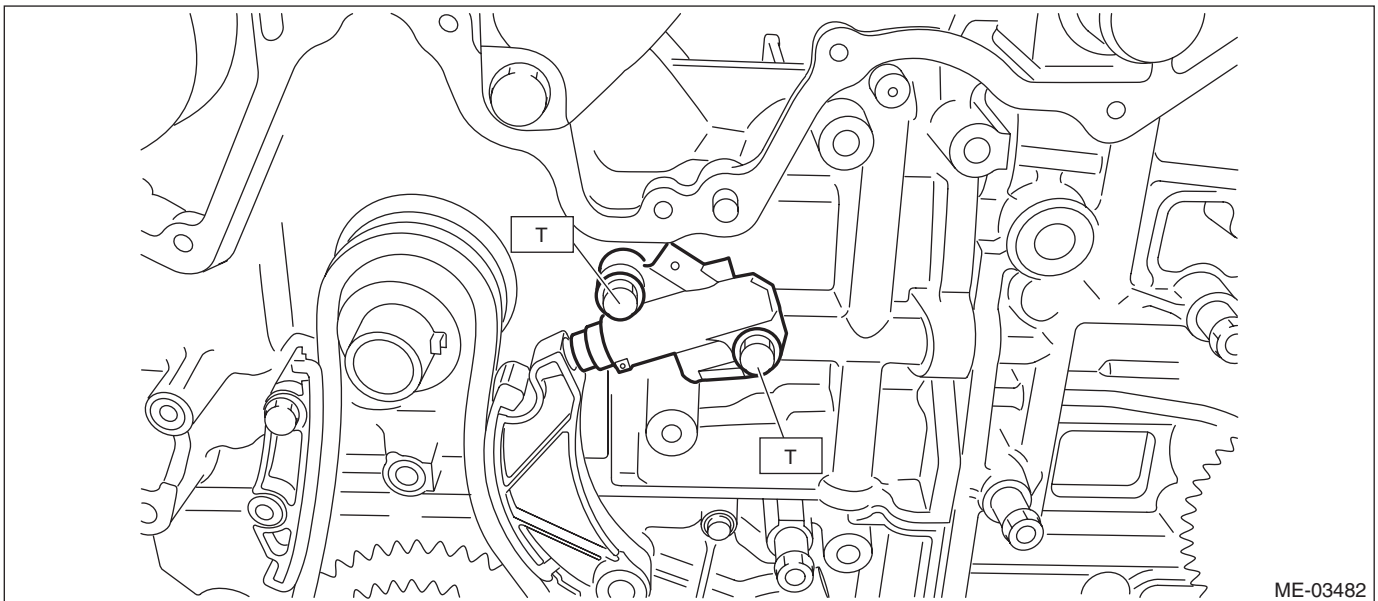

ME-03482

Timing Chain Assembly

MECHANICAL

11) Install the chain guide (LH).

Tightening torque:

16 N·m (1.6 kgf-m, 11.8 ft-lb)

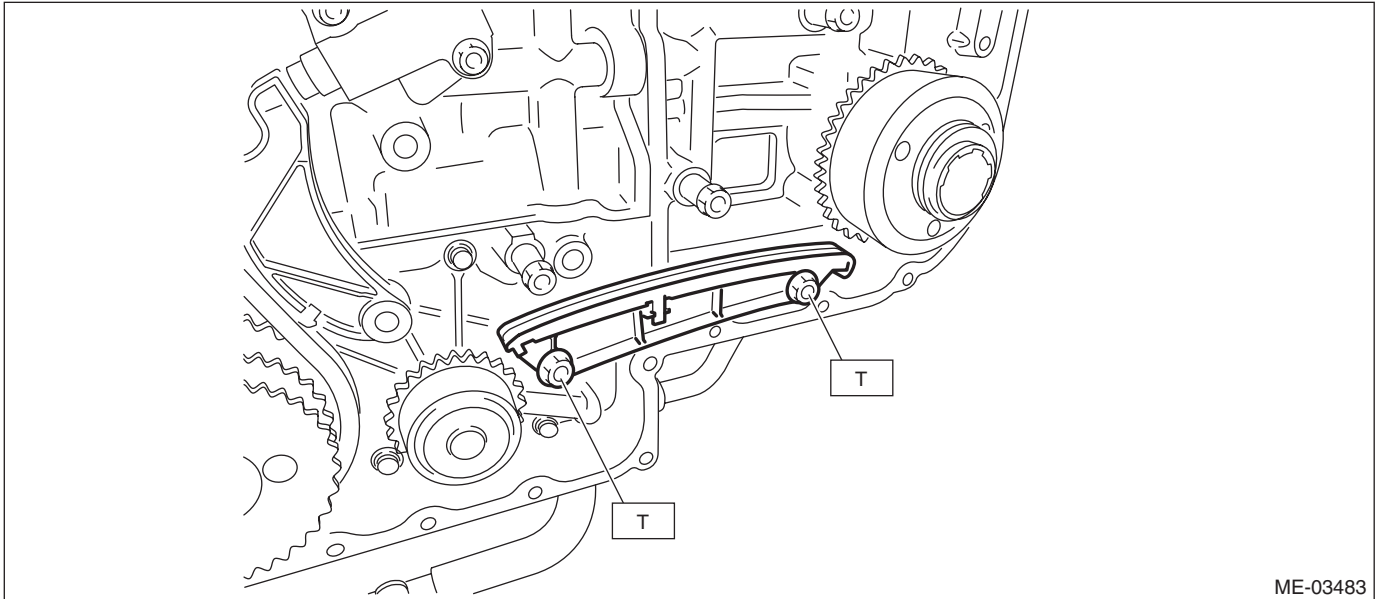

ME-03483

12) Install the chain guide (LH: between cams).

Tightening torque:

6.4 N·m (0.7 kgf-m, 4.7 ft-lb)

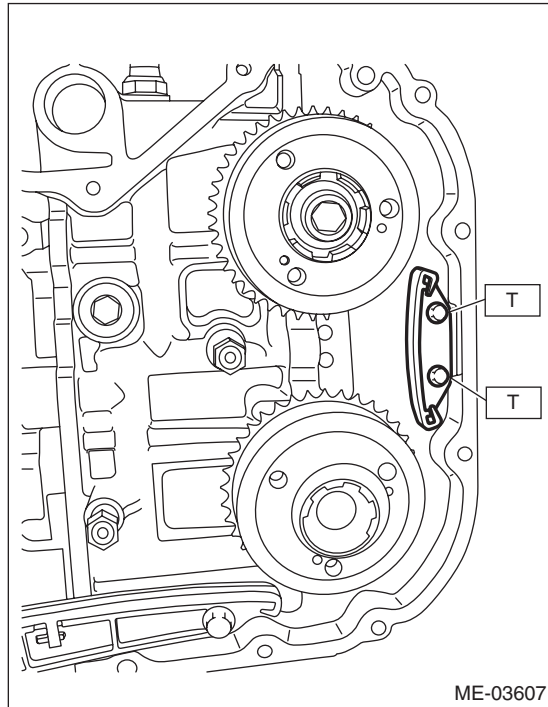

ME-03607

13) Install timing chain (LH).

(1) Match the timing mark of intake cam sprocket (LH) to the timing chain mark (blue).

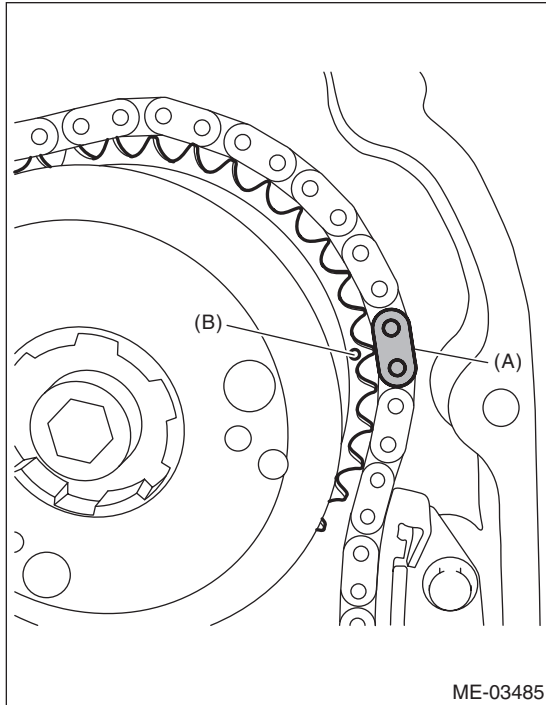

- (A) Blue
- (B) Timing mark

(2) Match the timing mark of exhaust cam sprocket (LH) to the timing chain mark (blue).

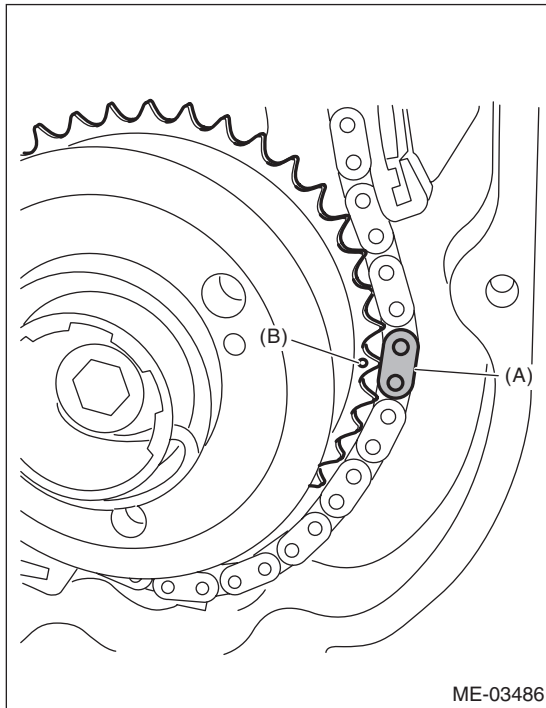

- (A) Blue
- (B) Timing mark

Timing Chain Assembly

MECHANICAL

(3) Install the timing chain to the water pump sprocket.

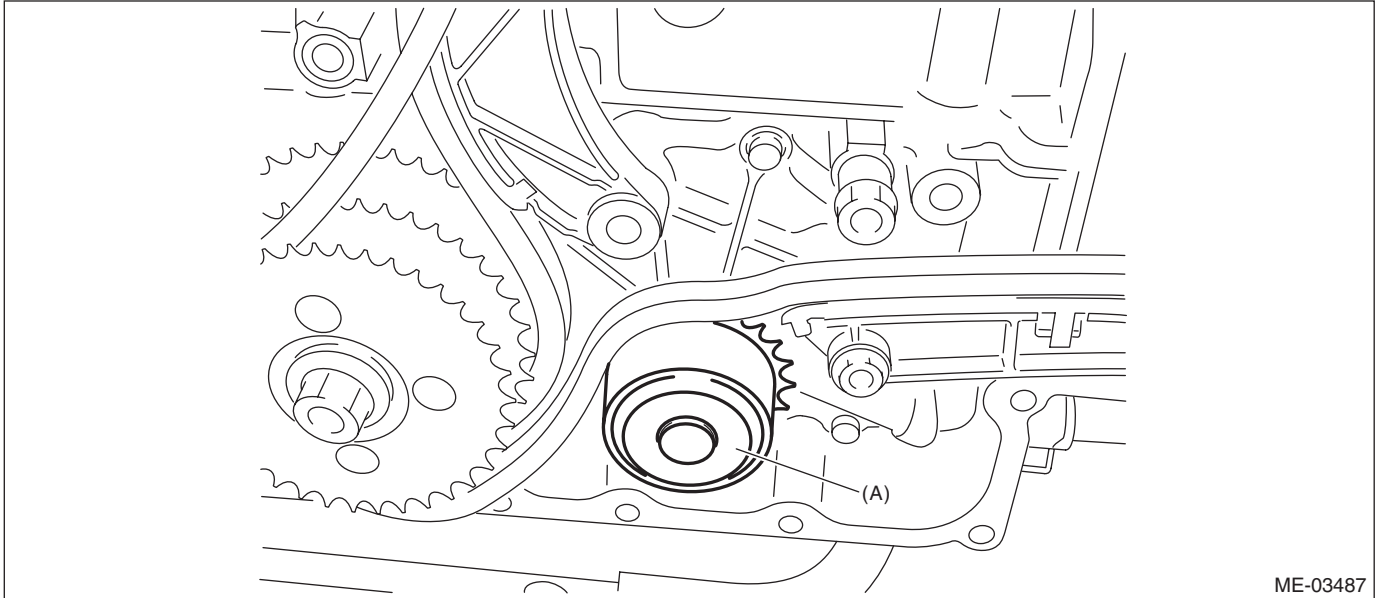

ME-03487

(A) Water pump sprocket

(4) Match the timing mark of idler sprocket to the timing chain mark (gold).

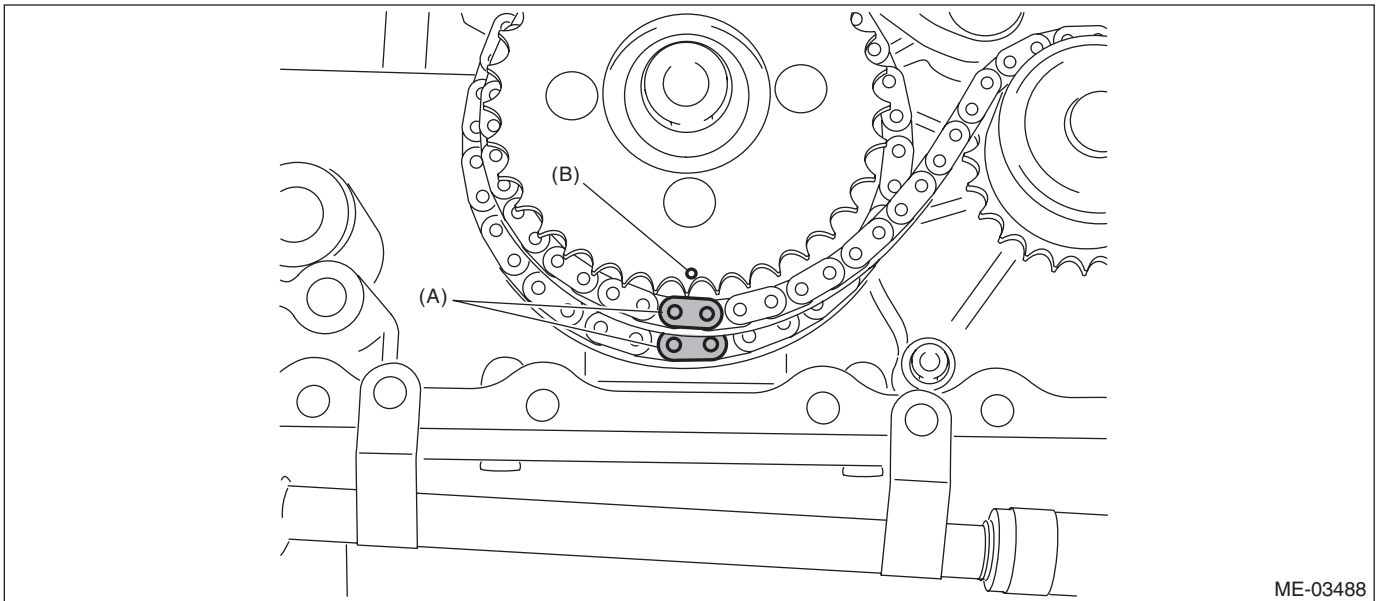

ME-03488

(A) Gold

(B) Timing mark

Timing Chain Assembly

MECHANICAL

14) Install the chain tensioner lever (LH).

Tightening torque:

16 N·m (1.6 kgf·m, 11.8 ft·lb)

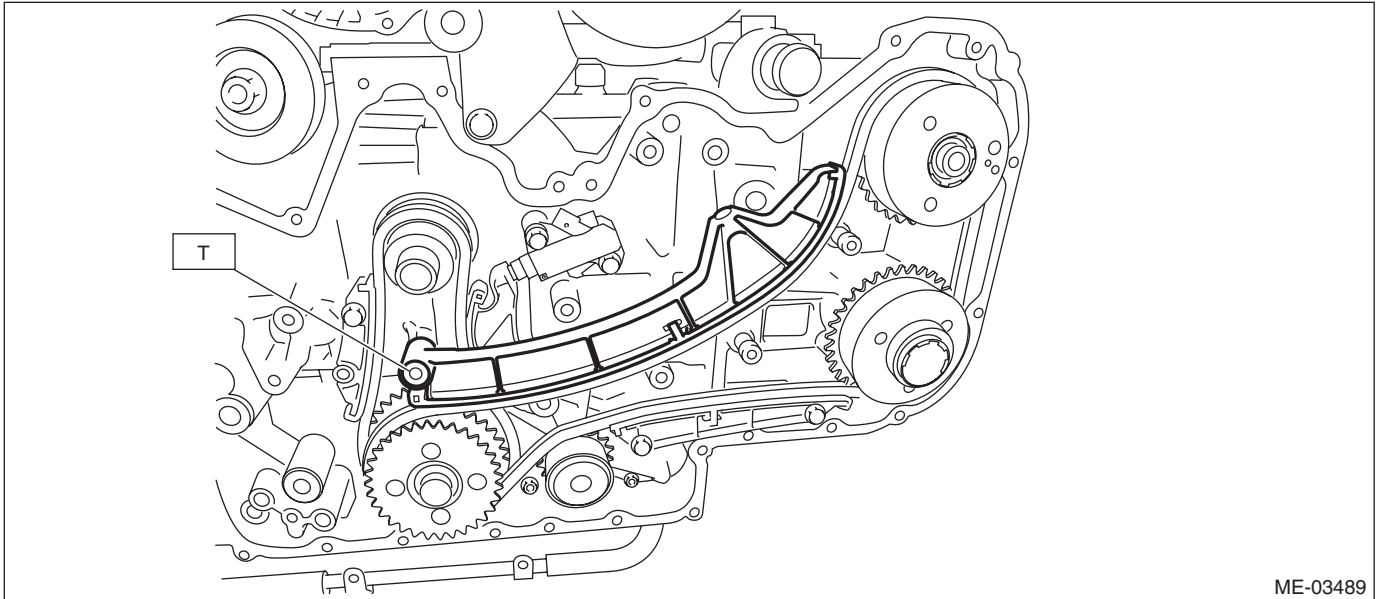

ME-03489

15) Install the chain tensioner (LH) and pull out the stopper pin.

NOTE:

- Make sure that there is a bolt attached on the side face of the chain tensioner housing.
- The timing chain (LH) line will be complete.

Tightening torque:

16 N·m (1.6 kgf·m, 11.8 ft·lb)

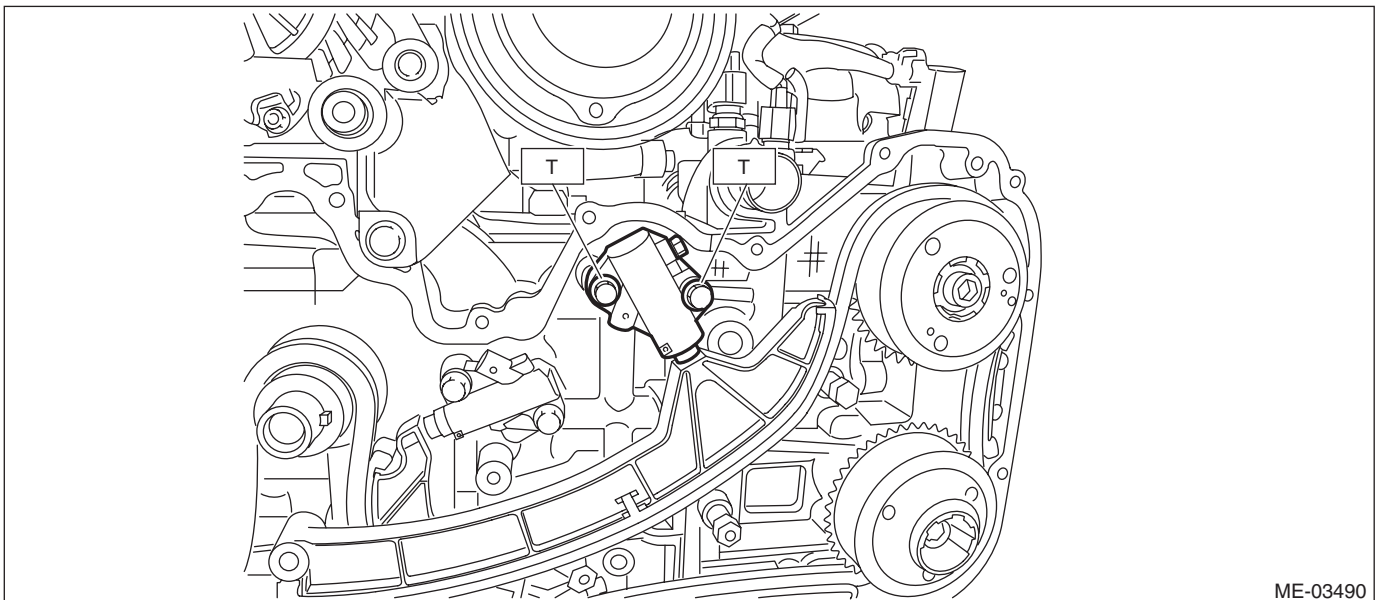

ME-03490

Timing Chain Assembly

MECHANICAL

16) Install the chain guide (RH).

Tightening torque:

16 N·m (1.6 kgf-m, 11.8 ft-lb)

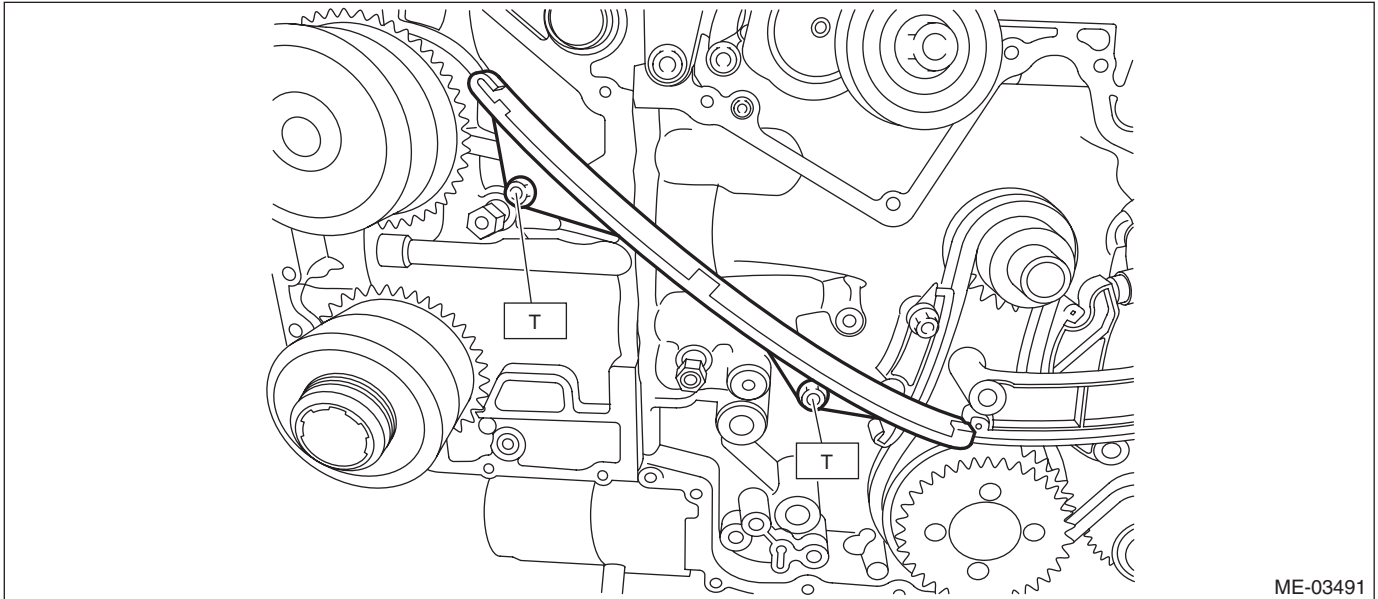

ME-03491

17) Install the chain guide (RH: between cams).

Tightening torque:

6.4 N·m (0.7 kgf-m, 4.7 ft-lb)

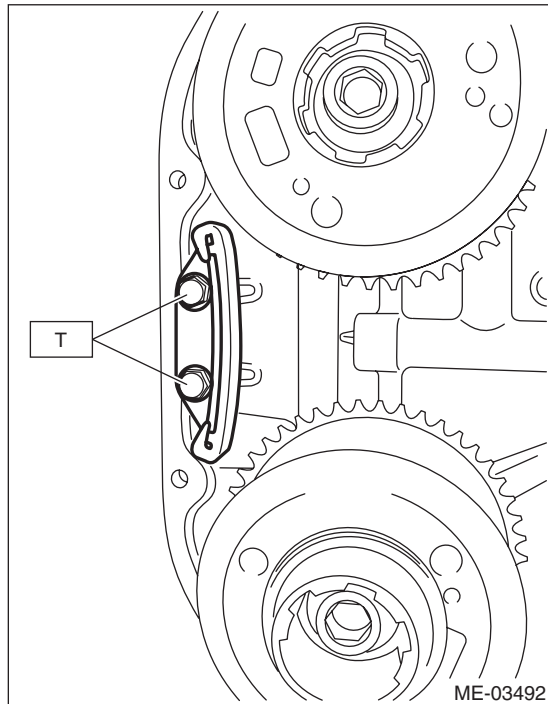

ME-03492

Timing Chain Assembly

MECHANICAL

18) Install timing chain (RH).

(1) Match the timing mark of intake cam sprocket (RH) to the timing chain mark (blue).

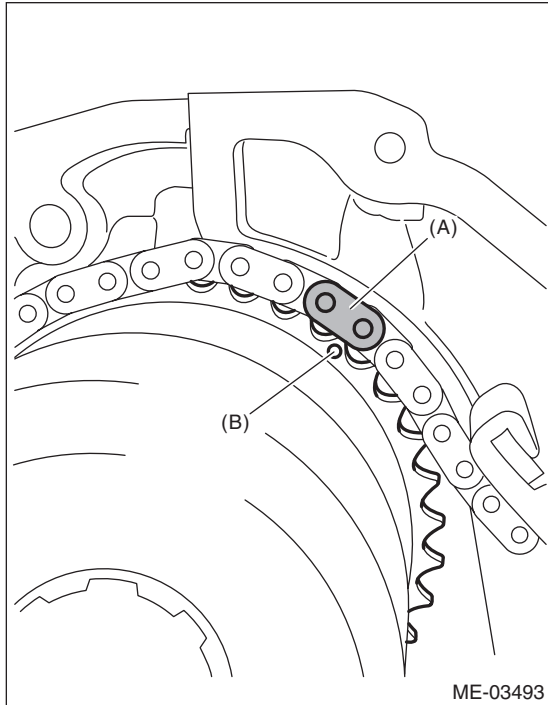

(A) Blue

(B) Timing mark

(2) Match the timing mark of exhaust cam sprocket (RH) to the timing chain mark (blue).

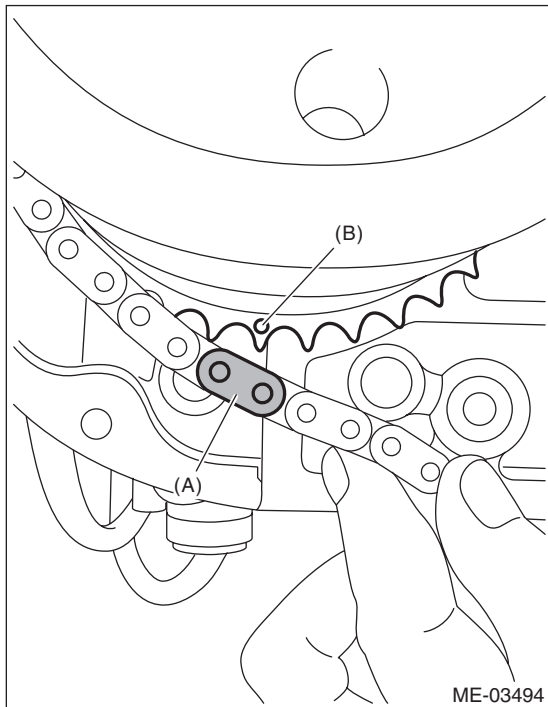

(A) Blue

(B) Timing mark

Timing Chain Assembly

MECHANICAL

(3) Match the timing mark of idler sprocket to the timing chain mark (gold).

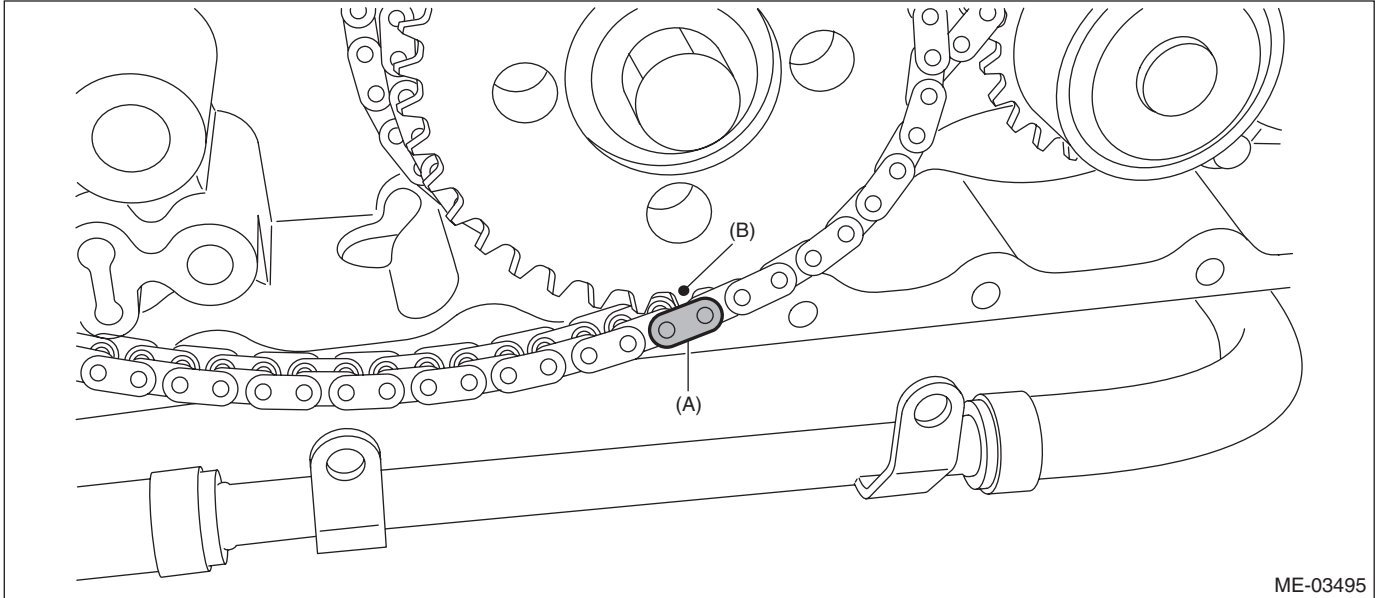

ME-03495

(A) Gold

(B) Timing mark

19) Install the chain tensioner lever (RH).

Tightening torque:

16 N·m (1.6 kgf·m, 11.8 ft·lb)

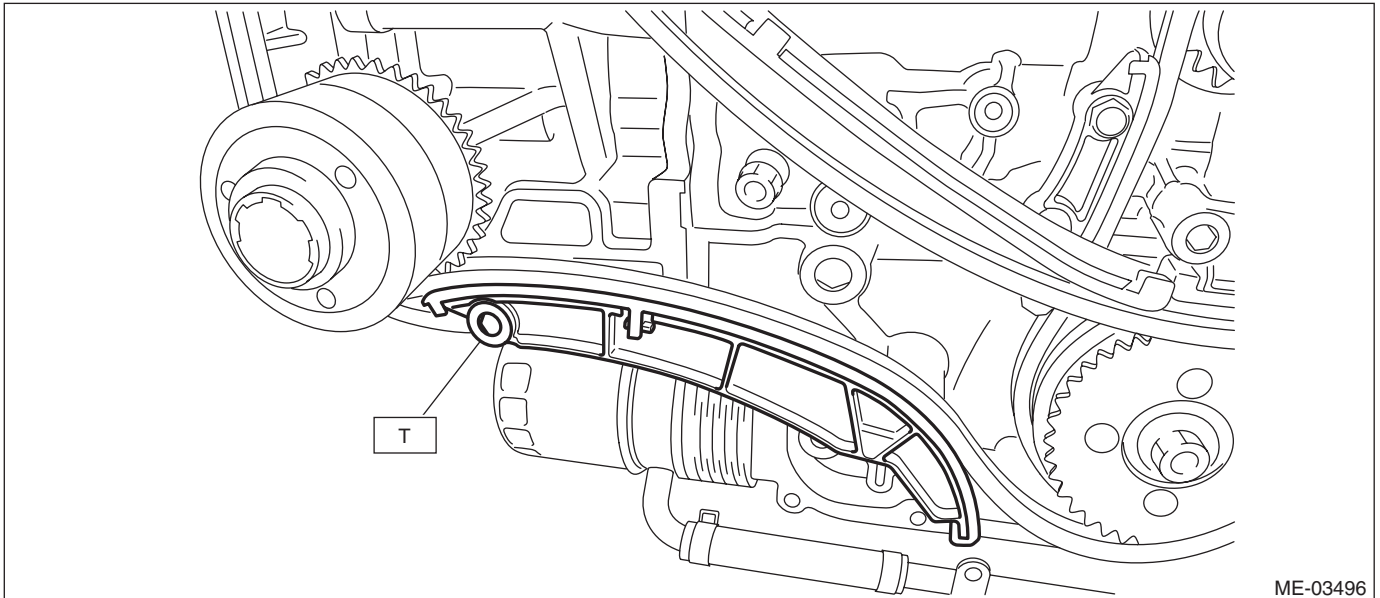

ME-03496

20) Install the chain tensioner (RH) and pull out the stopper pin.

NOTE:

The timing chain (RH) line will be complete.

Tightening torque:

16 N·m (1.6 kgf·m, 11.8 ft·lb)

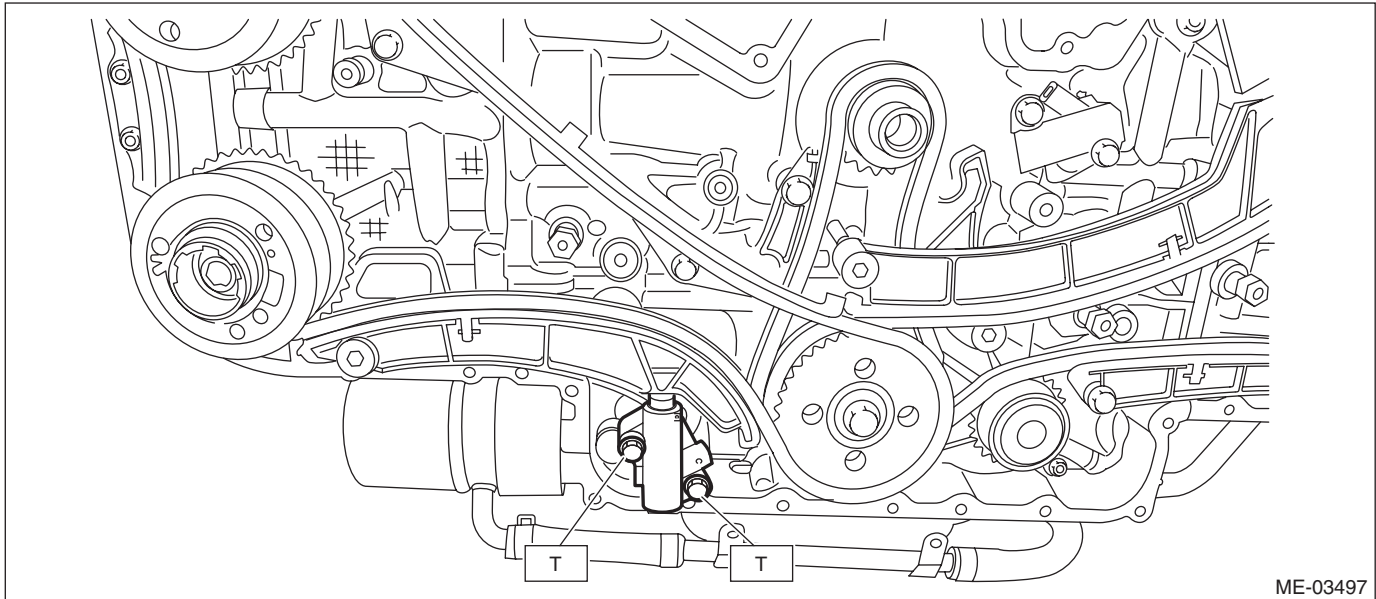

21) After installation, perform the following confirmations.

CAUTION:

Always make sure to perform this confirmation.

- (1) Make sure that the timing mark of idler sprocket is aligned to three timing chain marks (gold).
 - (2) Make sure that the twelve o'clock position on the crank sprocket is aligned to the timing chain (main) mark (gold).
 - (3) Make sure that the LH side cam sprocket timing mark is aligned to the timing chain mark (blue).
 - (4) Make sure that the RH side cam sprocket timing mark is aligned to the timing chain mark (blue).
 - (5) Make sure that all bolts are tightened at the specified torque.
- 22) Using the ST, turn the crankshaft in the direction of engine rotation, and make sure that there are no abnormal conditions.

CAUTION:

Always make sure to perform this confirmation.

- 23) Install the chain cover. <Ref. to ME(H6DO)-50, INSTALLATION, Chain Cover.>
- 24) Install the crank pulley. <Ref. to ME(H6DO)-47, INSTALLATION, Crank Pulley.>
- 25) Install the V-belts. <Ref. to ME(H6DO)-46, INSTALLATION, V-belt.>
- 26) Fill engine oil. <Ref. to LU(H6DO)-10, REPLACEMENT, Engine Oil.>
- 27) Make sure there is no oil leaks in the chain cover mating surface.
- 28) Install the radiator. <Ref. to CO(H6DO)-19, INSTALLATION, Radiator.>