

17. Crank Sprocket

A: REMOVAL

- 1) Remove the V-belts. <Ref. to ME(H6DO)-46, REMOVAL, V-belt.>
- 2) Remove the crank pulley. <Ref. to ME(H6DO)-47, REMOVAL, Crank Pulley.>
- 3) Remove the chain cover. <Ref. to ME(H6DO)-48, REMOVAL, Chain Cover.>
- 4) Remove the timing chain assembly. <Ref. to ME(H6DO)-55, REMOVAL, Timing Chain Assembly.>
- 5) Remove the crank sprocket (A).

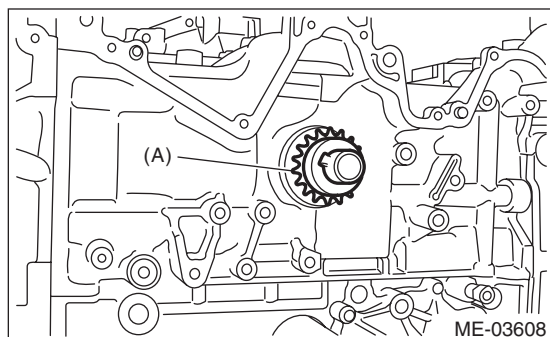

B: INSTALLATION

- 1) Install the crank sprocket (A).

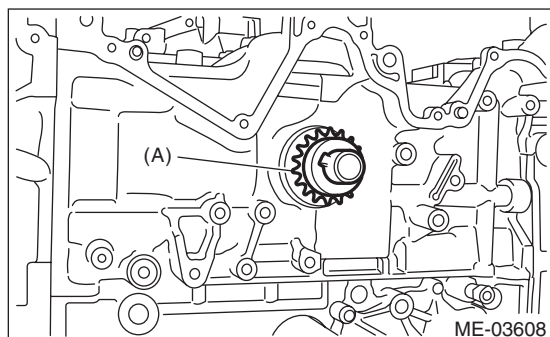

- 2) Install the timing chain assembly. <Ref. to ME(H6DO)-61, INSTALLATION, Timing Chain Assembly.>
- 3) Install the chain cover. <Ref. to ME(H6DO)-50, INSTALLATION, Chain Cover.>
- 4) Install the crank pulley. <Ref. to ME(H6DO)-47, INSTALLATION, Crank Pulley.>
- 5) Install the V-belts. <Ref. to ME(H6DO)-46, INSTALLATION, V-belt.>

C: INSPECTION

- 1) Check the crank sprocket teeth for abnormal wear and scratches.
- 2) Make sure there is no free play between crank sprocket and key.