

# Camshaft

MECHANICAL

## 18. Camshaft

### A: REMOVAL

- 1) Remove the engine from vehicle. <Ref. to ME(H6DO)-36, REMOVAL, Engine Assembly.>
- 2) Remove the crank pulley. <Ref. to ME(H6DO)-47, REMOVAL, Crank Pulley.>
- 3) Remove the chain cover. <Ref. to ME(H6DO)-48, REMOVAL, Chain Cover.>
- 4) Remove the timing chain assembly. <Ref. to ME(H6DO)-55, REMOVAL, Timing Chain Assembly.>
- 5) Remove the cam sprocket. <Ref. to ME(H6DO)-74, REMOVAL, Cam Sprocket.>
- 6) Remove the crank sprocket. <Ref. to ME(H6DO)-75, REMOVAL, Crank Sprocket.>
- 7) Remove the exhaust oil flow control solenoid valve. <Ref. to FU(H6DO)-45, REMOVAL, Oil Flow Control Solenoid Valve.>
- 8) Remove the camshaft position sensor. <Ref. to FU(H6DO)-34, REMOVAL, Camshaft Position Sensor.>
- 9) Loosen the rocker cover bolts in the order indicated in the figure, and remove the rocker cover.
  - LH side

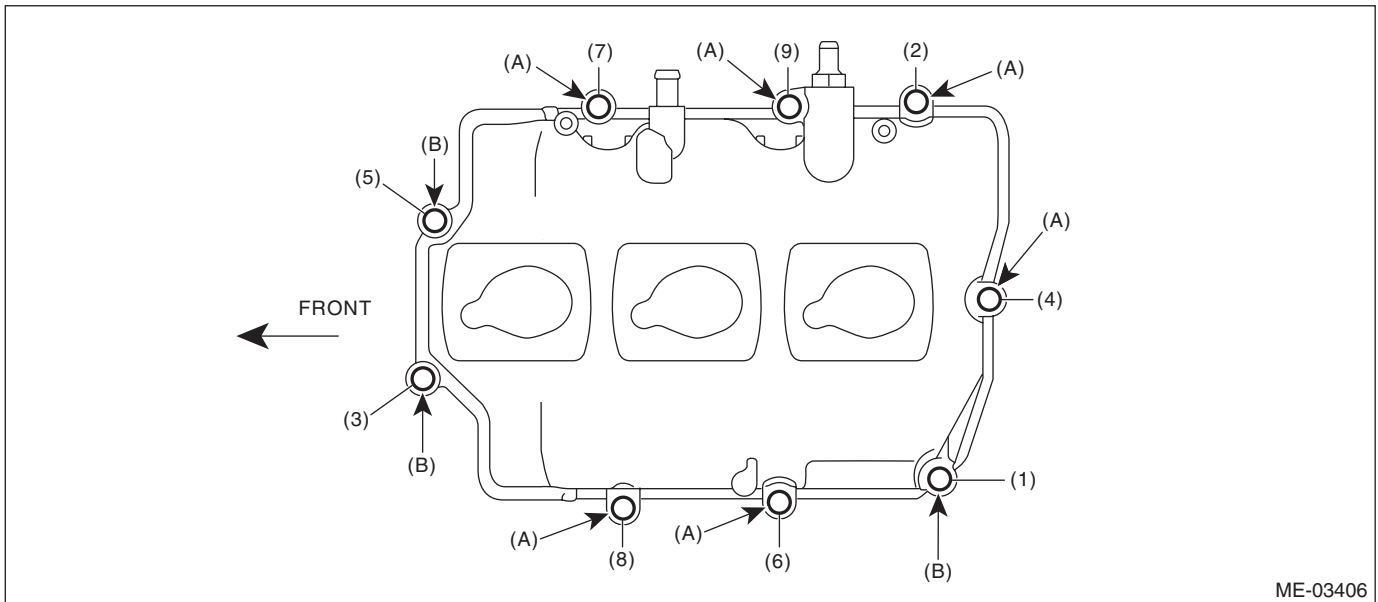

ME-03406

(A) M6 × 39.5

(B) M6 × 26.3

- RH side

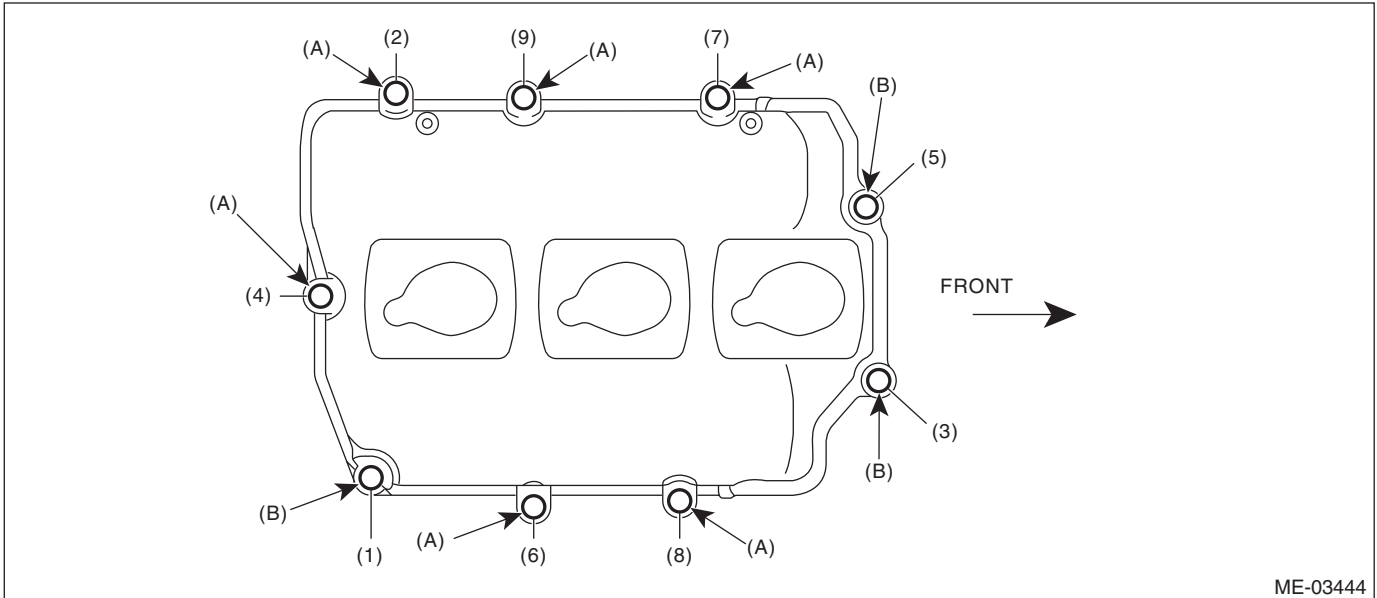

ME-03444

(A) M6 × 39.5

(B) M6 × 26.3

10) Loosen the camshaft cap bolts equally, a little at a time in numerical sequence as shown in the figure.

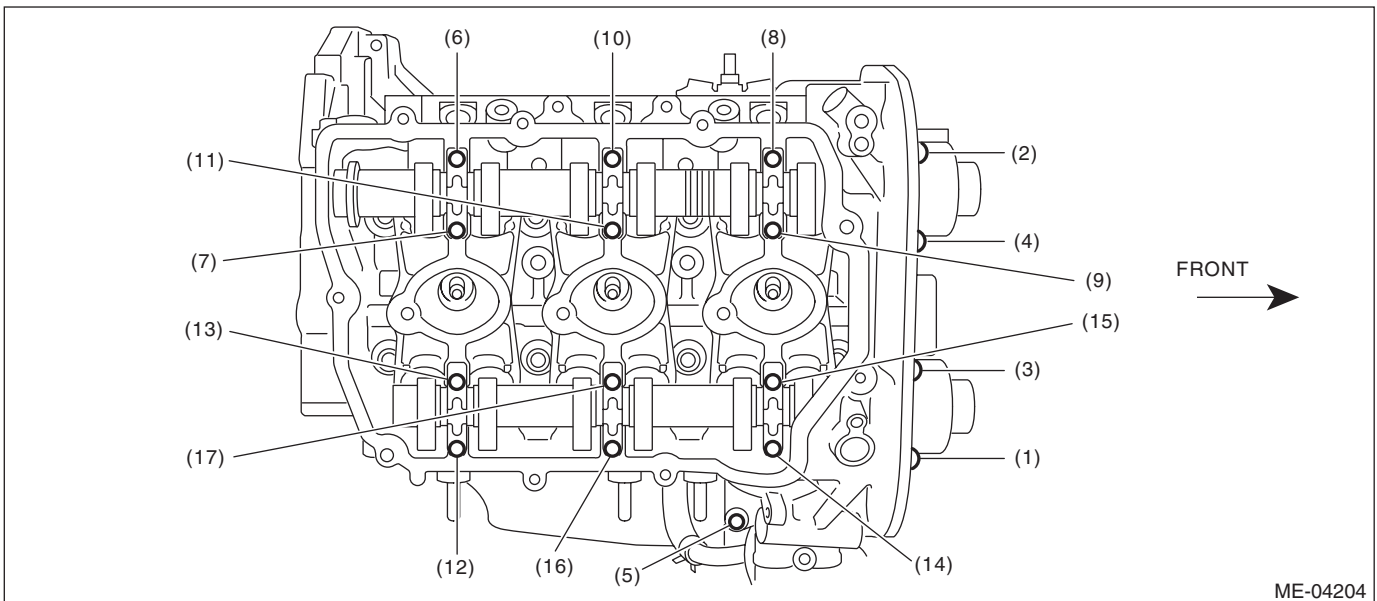

ME-04204

11) Remove the camshaft caps and camshaft (RH).

**NOTE:**

Arrange camshaft caps in order so that they can be installed in their original positions.

12) Similarly, remove the camshafts (LH) and related parts.

# Camshaft

MECHANICAL

## B: INSTALLATION

- 1) Apply engine oil to camshaft journals, and install the camshaft.
- 2) Install the camshaft cap.

(1) Apply liquid gasket sparingly to back side of the front camshaft cap as shown in the figure.

NOTE:

- Install within 5 min. after applying liquid gasket.
- Do not apply liquid gasket excessively. Applying excessively may cause excess gasket to come out and flow toward cam journal, resulting in engine seizure.

**Liquid gasket:**

**THREE BOND 1217G (Part No. K0877Y0100) or equivalent**

**Liquid gasket applying diameter:**

**$2.0 \pm 0.5$  mm ( $0.079 \pm 0.020$  in)**

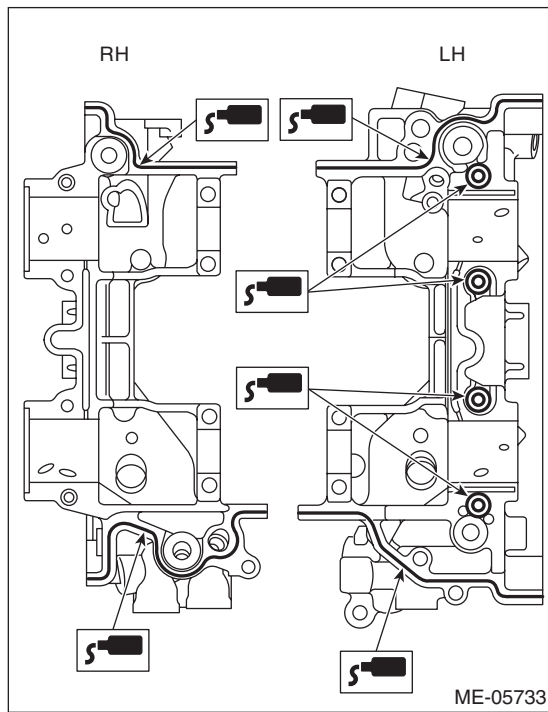

(2) Install the O-ring to the front camshaft cap.

**NOTE:**

Use new O-rings.

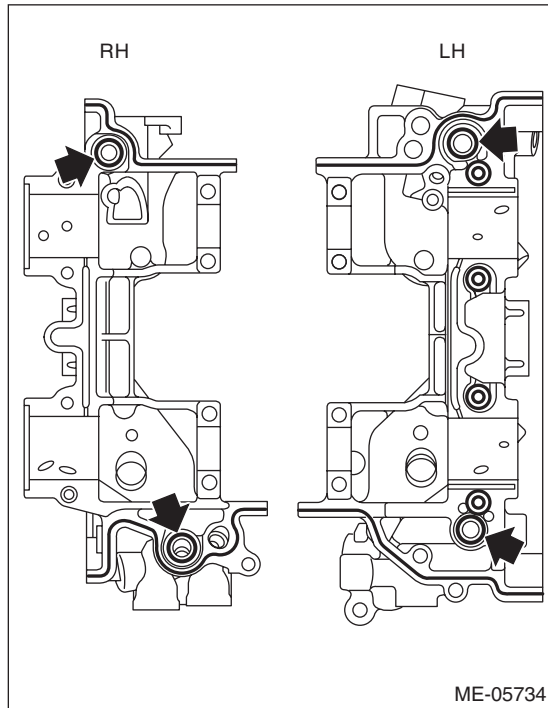

(3) Apply a thin coat of engine oil to the cap journal surface, and install the camshaft cap to the camshaft.

(4) Gradually tighten the camshaft cap in at least two stages in the numerical order shown in the figure, then tighten to specified torque.

**Tightening torque:**

**(1) — (12): 16 N·m (1.6 kgf·m, 11.8 ft·lb)**

**(13) — (17): 9.75 N·m (1.0 kgf·m, 7.2 ft·lb)**

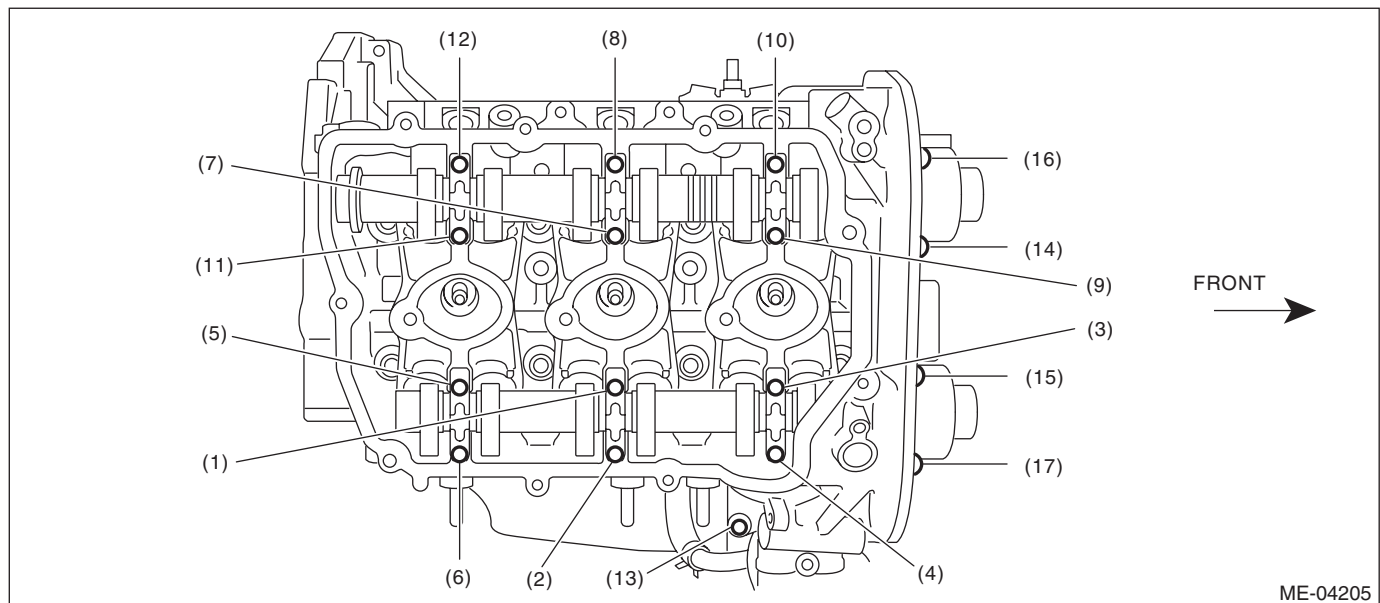

(5) After tightening the camshaft cap, ensure the camshaft rotates only slightly while holding it at base circle.

3) Install the rocker cover.

(1) Install the rocker cover gasket to the rocker cover.

**NOTE:**

Use a new rocker cover gasket.

# Camshaft

## MECHANICAL

(2) Apply liquid gasket sparingly to the mating surface of cylinder head and rocker cover as shown in the figure.

### NOTE:

- Install within 5 min. after applying liquid gasket.
- Do not apply liquid gasket excessively. Applying excessively may cause excess gasket to come out and flow toward cam journal, resulting in engine seizure.

### Liquid gasket:

**THREE BOND 1217G (Part No. K0877Y0100) or equivalent**

### Liquid gasket applying diameter:

**$3.5 \pm 0.5$  mm ( $0.138 \pm 0.020$  in)**

- LH side

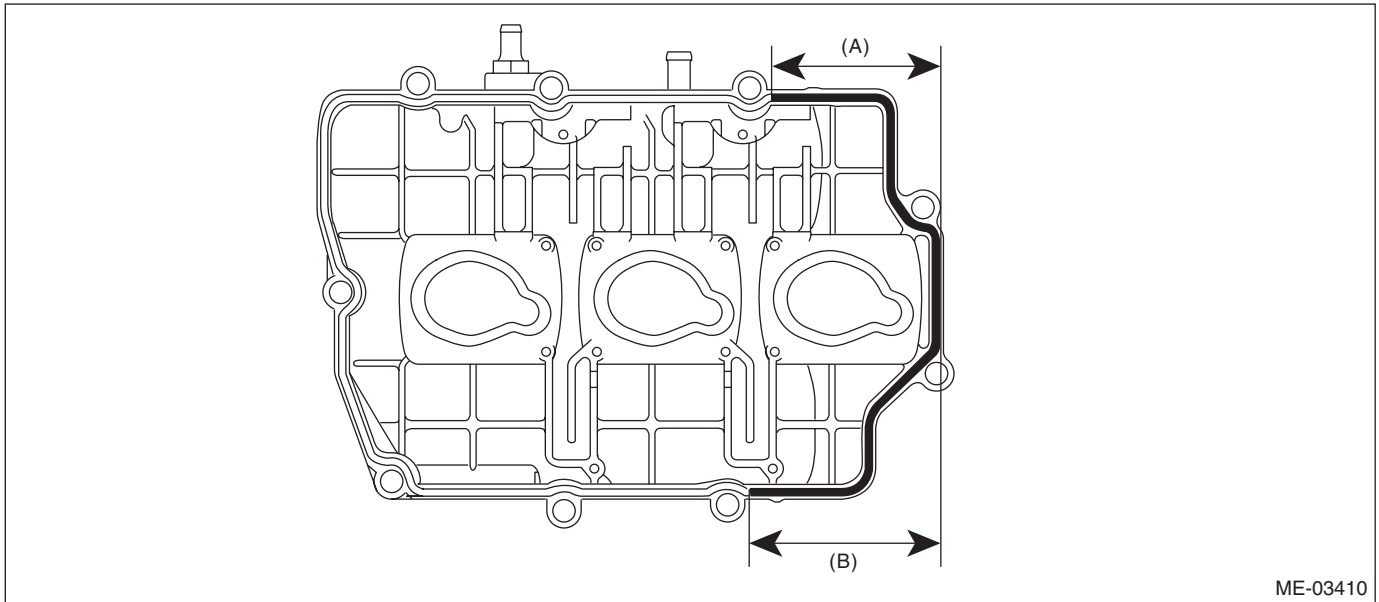

(A) 90 mm (3.543 in) or more

(B) 105 mm (4.134 in) or more

- RH side

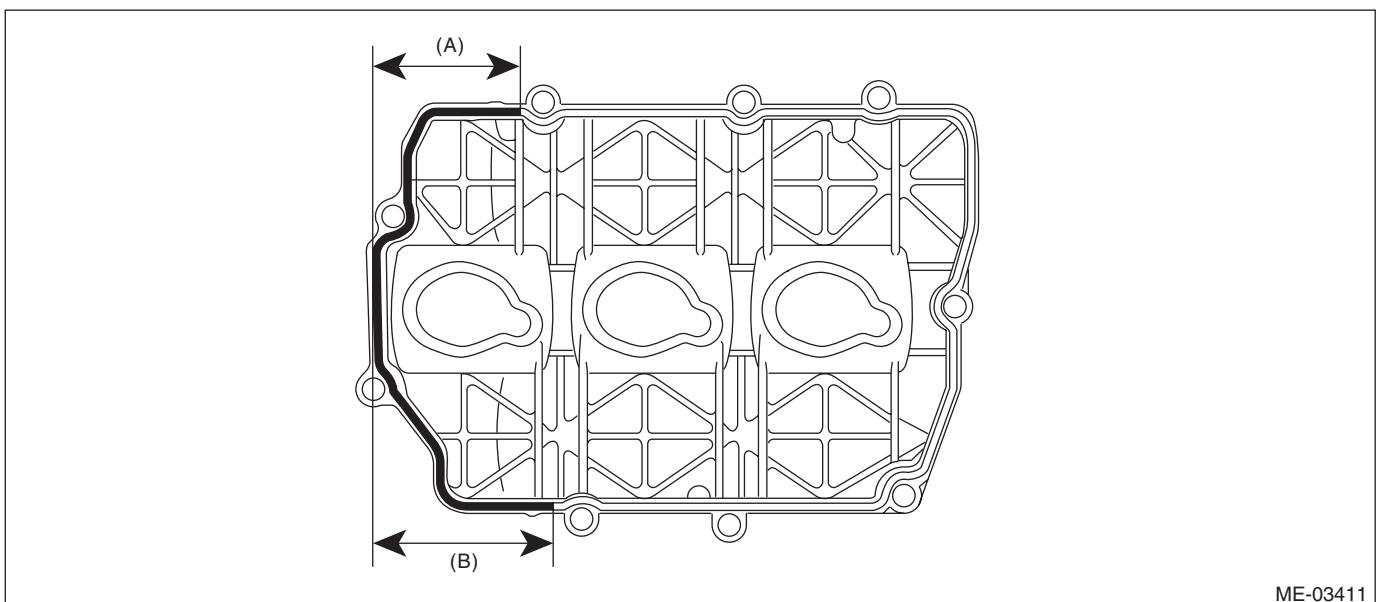

(A) 80 mm (3.150 in) or more

(B) 100 mm (3.937 in) or more

(3) Tighten the rocker cover bolts in the numerical order as shown in the figure.

**Tightening torque:**

**6.4 N·m (0.7 kgf-m, 4.7 ft-lb)**

- LH side

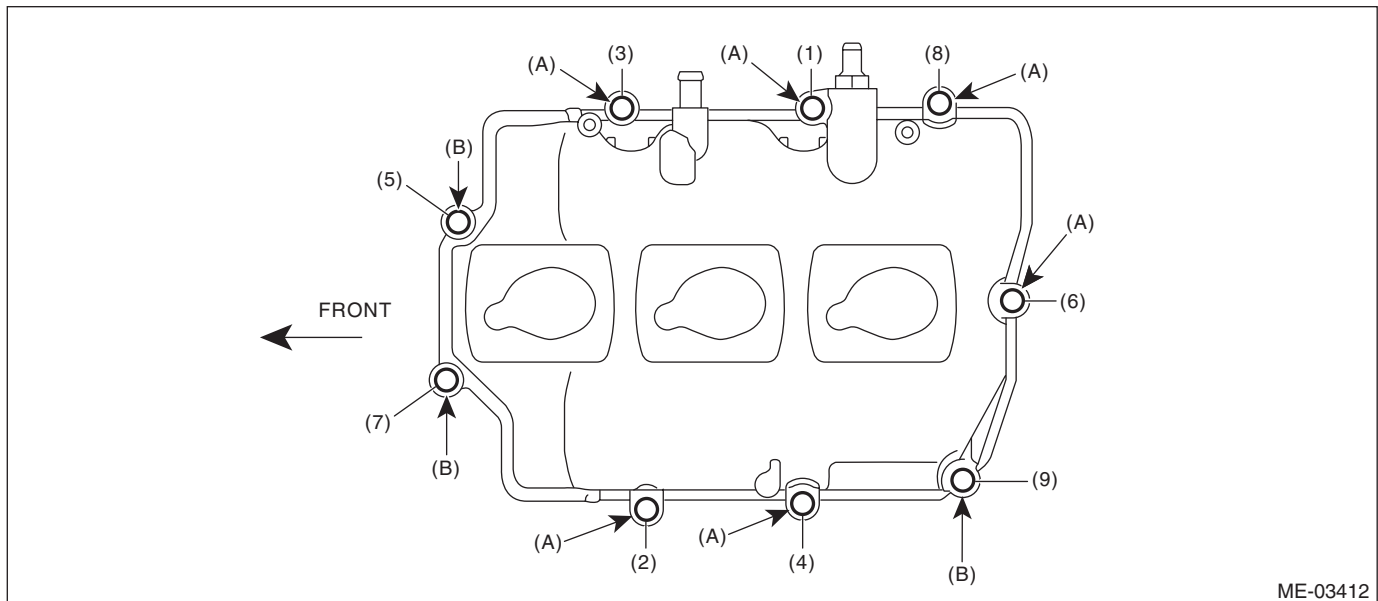

(A) M6 × 39.5

(B) M6 × 26.3

- RH side

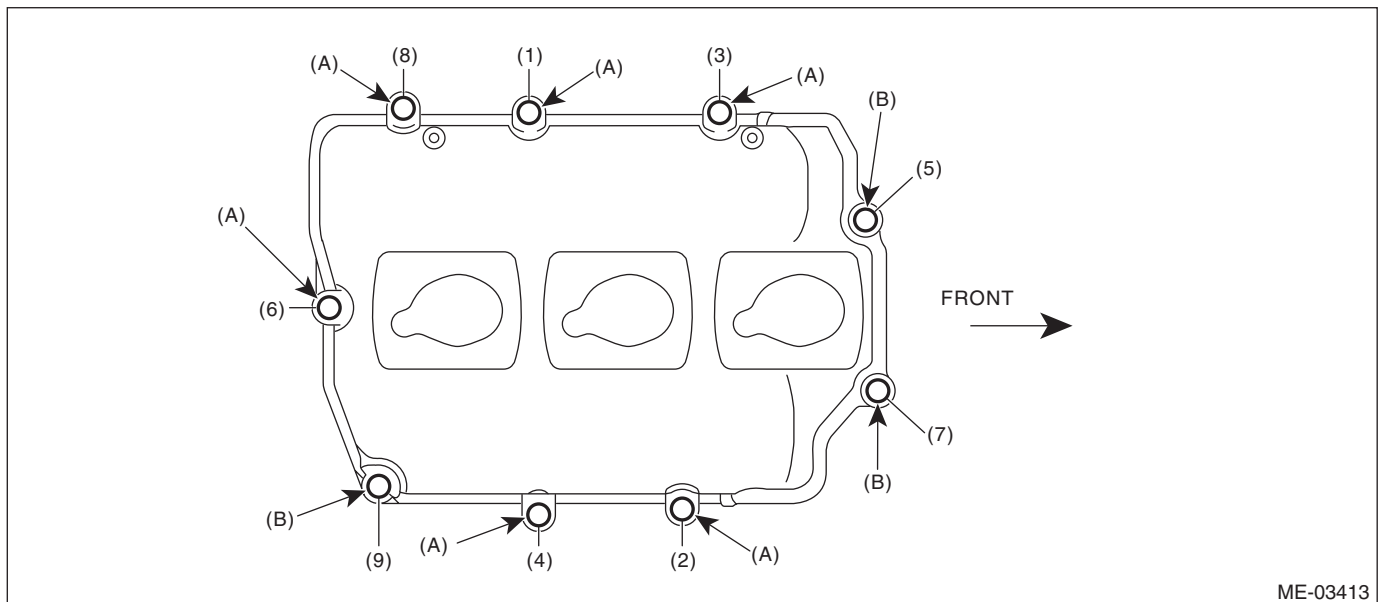

(A) M6 × 39.5

(B) M6 × 26.3

- 4) Install the crank sprocket. <Ref. to ME(H6DO)-75, INSTALLATION, Crank Sprocket.>
- 5) Install the cam sprocket. <Ref. to ME(H6DO)-74, INSTALLATION, Cam Sprocket.>
- 6) Install the timing chain assembly. <Ref. to ME(H6DO)-61, INSTALLATION, Timing Chain Assembly.>
- 7) Install the chain cover. <Ref. to ME(H6DO)-50, INSTALLATION, Chain Cover.>
- 8) Install the crank pulley. <Ref. to ME(H6DO)-47, INSTALLATION, Crank Pulley.>
- 9) Install the engine to the vehicle. <Ref. to ME(H6DO)-40, INSTALLATION, Engine Assembly.>

# Camshaft

## MECHANICAL

### C: INSPECTION

1) Measure the bend, and repair or replace if necessary.

**Camshaft bend limit:**  
**0.020 mm (0.00079 in)**

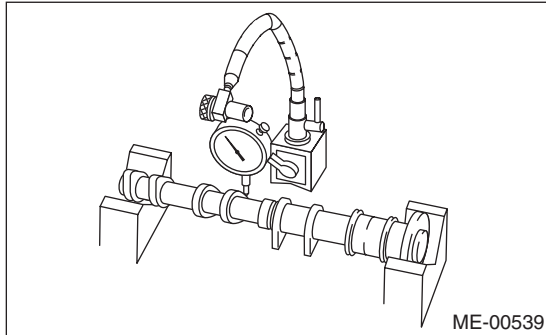

2) Check the journal for damage and wear. Replace if faulty.

3) Check the cutout portion used for camshaft sensor for damage. Replace if faulty.

4) Check the cam face condition; remove the minor faults by grinding with oil stone. Replace if there is uneven wear or others.

5) Measure the cam lobe height "H" and cam base circle diameter "A". If it exceeds the standard or offset wear occurs, replace it.

**Cam lobe height H:**

**Standard**

**Intake**

**45.90 — 46.00 mm (1.8071 — 1.8110 in)**

**Exhaust**

**44.65 — 44.75 mm (1.7579 — 1.7618 in)**

**Cam base circle diameter A:**

**Standard**

**Intake**

**36.00 mm (1.4173 in)**

**Exhaust**

**36.00 mm (1.4137 in)**

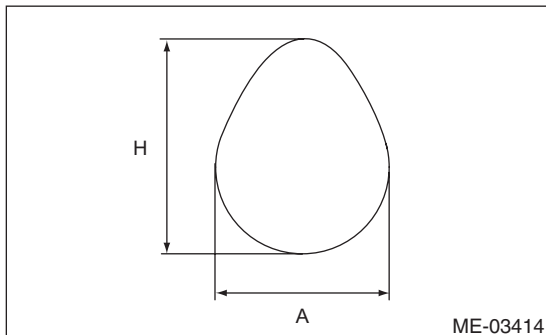

6) Measure the outside diameter of camshaft journal. If the journal diameter is not within specification, check the oil clearance.

	Camshaft journal	
	Front	Except for front
Standard mm (in)	37.946 — 37.963 (1.4939 — 1.4946)	25.946 — 25.963 (1.0215 — 1.0222)

7) Measure the oil clearance of camshaft journal.

- (1) Clean the camshaft cap and cylinder head camshaft journal.
- (2) Place the camshaft on cylinder head. (Without installing the valve lifter)
- (3) Place a plastigauge across each camshaft journals.
- (4) Gradually tighten the camshaft cap in at least two stages in the numerical order shown in the figure, then tighten to specified torque. Do not turn the camshaft.

**Tightening torque:**

- (1) — (12): 16 N·m (1.6 kgf·m, 11.8 ft·lb)**  
**(13) — (17): 9.75 N·m (1.0 kgf·m, 7.2 ft·lb)**

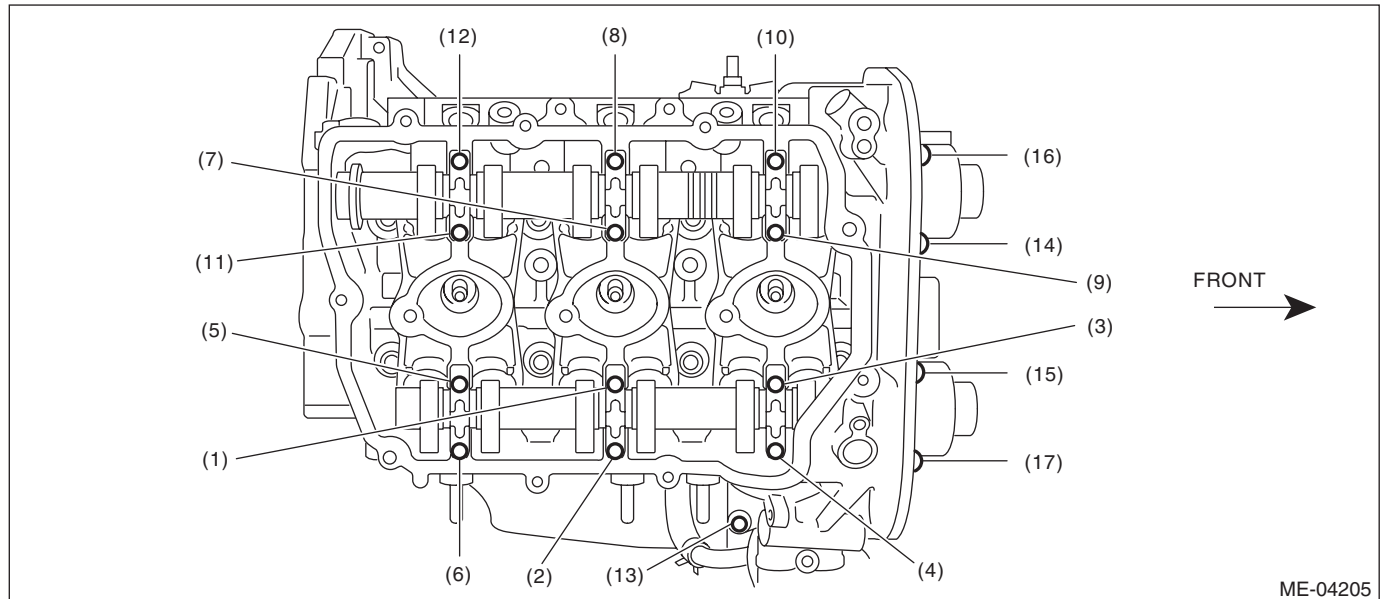

- (5) Remove the camshaft cap.
- (6) Measure the widest point of the plastigauge on each journal. If oil clearance exceeds the standard, replace the camshaft. If necessary, replace the camshaft caps and cylinder head as a set.

- 8) Measure the thrust clearance with setting the dial gauge at end surface of camshaft. If the thrust clearance is not within the standard or there is off-set wear, replace the camshaft caps and cylinder head as a set. If necessary replace the camshaft.

**Camshaft thrust clearance:**

**Standard**

**Intake**

**0.075 — 0.135 mm (0.0030 — 0.0053 in)**

**Exhaust**

**0.075 — 0.135 mm (0.0030 — 0.0053 in)**

**Camshaft oil clearance:**

**Standard**

**0.037 — 0.072 mm (0.0015 — 0.0028 in)**

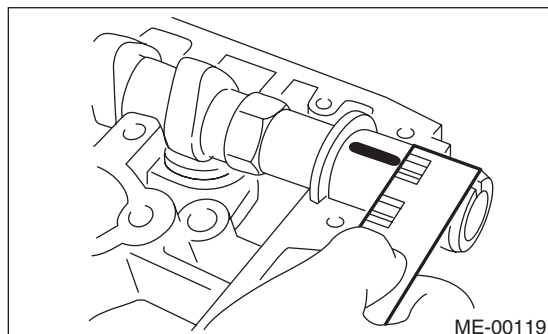

- (7) Completely remove the plastigauge.