

4. Ignition Timing

A: INSPECTION

CAUTION:

After warming-up, engine becomes very hot. Be careful not to burn yourself at measurement.

1. METHOD WITH SUBARU SELECT MONITOR

1) Before checking the ignition timing, check the following item:

- (1) Check the air cleaner element is free from clogging, spark plugs are in good condition, and hoses are connected properly.
- (2) Check the malfunction indicator light does not illuminate.

2) Warm up the engine.

3) Read the ignition timing using Subaru Select Monitor. <Ref. to EN(H6DO)(diag)-38, READ CURRENT DATA FOR ENGINE (NORMAL MODE), OPERATION, Subaru Select Monitor.>

NOTE:

If ignition timing is out of standard, check the ignition control system. Refer to "Engine Control System". <Ref. to EN(H6DO)(diag)-2, Basic Diagnostic Procedure.>

Ignition timing [BTDC/rpm]:

Standard

$15^{\circ} \pm 8^{\circ} / 700$

2. METHOD WITH TIMING LIGHT

1) Before checking the ignition timing, check the following item:

- (1) Check the air cleaner element is free from clogging, spark plugs are in good condition, and hoses are connected properly.
- (2) Check the malfunction indicator light does not illuminate.

2) Warm up the engine.

3) Stop the engine, and turn the ignition switch to OFF.

4) Remove the collector cover.

5) Disconnect the ground cable from battery.

6) Remove the air intake duct. <Ref. to IN(H6DO)-8, REMOVAL, Air Intake Duct.>

7) Disconnect the connector from mass air flow and intake air temperature sensor.

8) Remove the air cleaner case and element.

9) Connect the timing light to the power wire of #1 ignition coil.

10) Install the connectors of air cleaner case, element, and the mass air flow and intake air temperature sensor.

11) Connect the battery ground terminal.

12) Start the engine, turn the timing light to the crank pulley, and check the ignition timing through the chain cover gauge.

NOTE:

If ignition timing is out of standard, check the ignition control system. Refer to "Engine Control System". <Ref. to EN(H6DO)(diag)-2, Basic Diagnostic Procedure.>

Ignition timing [BTDC/rpm]:

Standard

$15^{\circ} \pm 8^{\circ} / 700$

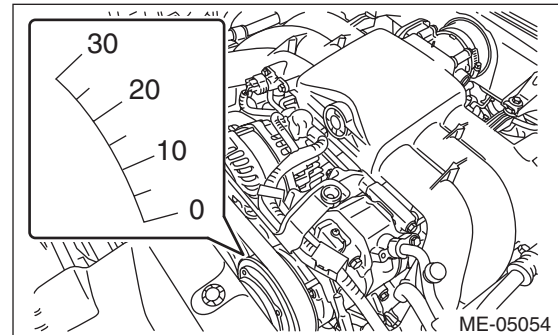

13) After inspection, install the related parts in the reverse order of removal.