

Valve Clearance

MECHANICAL

8. Valve Clearance

A: INSPECTION

CAUTION:

If engine oil is spilt onto the exhaust pipe, wipe it off with cloth to avoid emission of smoke or causing a fire.

NOTE:

Inspection of valve clearance should be performed while engine is cold.

- 1) Remove the collector cover.
- 2) Disconnect the ground cable from battery.
- 3) Lift up the vehicle.
- 4) Remove the under cover. <Ref. to EI-18, REMOVAL, Front Under Cover.>
- 5) Lower the vehicle.
- 6) When inspecting the valve clearances for #1, #3 and #5

- (1) Disconnect the brake booster vacuum hose from the intake manifold.

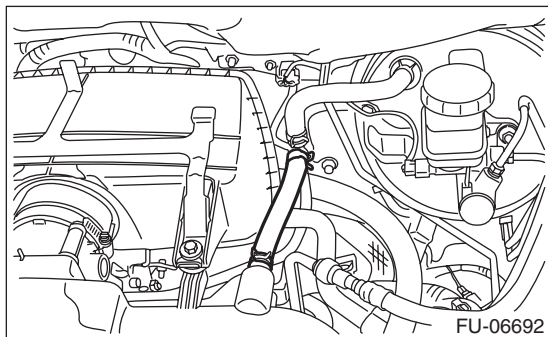

- (2) Loosen the clamp (A) which connects air intake chamber to throttle body.
- (3) Loosen the clamp (B) which connects intake boot to air intake chamber.
- (4) Loosen the bolt (C) which secures air intake chamber and collector cover bracket to the stay.

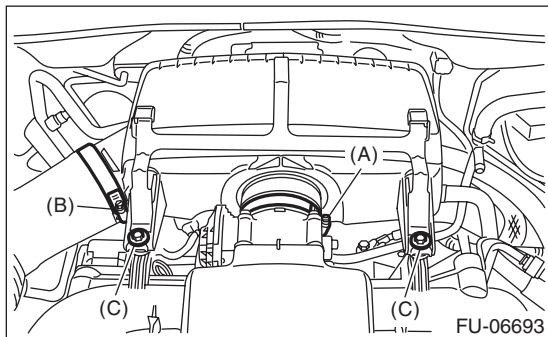

- (5) Remove the air intake chamber, and move it to the left side wheel apron.

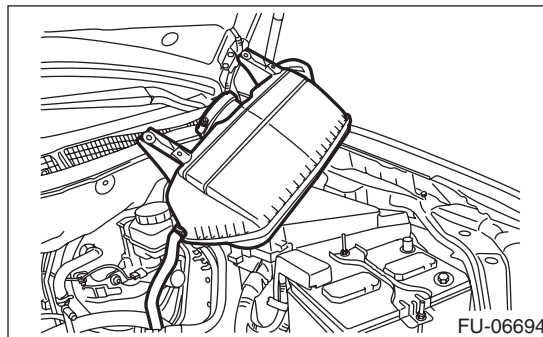

- (6) Remove the air cleaner case and intake boot. <Ref. to IN(H6DO)-5, REMOVAL, Air Cleaner Case.>
- (7) Remove the feed hose from the fuel pipe protector (RH).

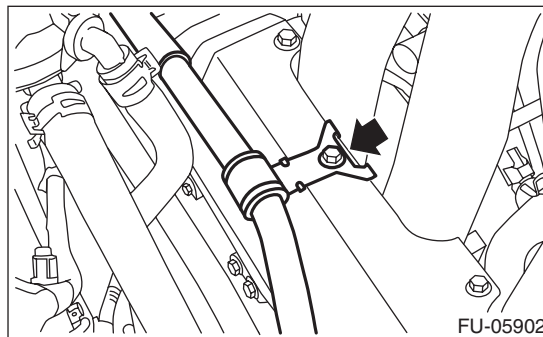

- (8) Remove the fuel pipe protector (RH).

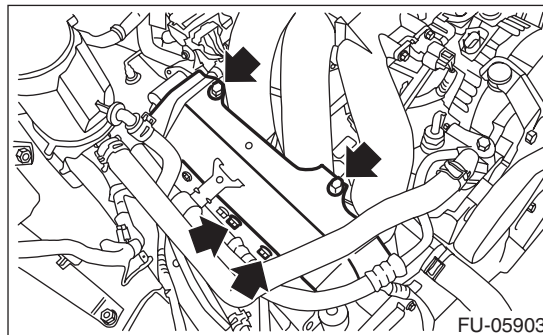

- (9) Disconnect the connector of oil pressure switch.
- (10) Remove the ignition coil. <Ref. to IG(H6DO)-7, REMOVAL, Ignition Coil.>
- (11) Remove the rocker cover (RH). <Ref. to ME(H6DO)-76, REMOVAL, Camshaft.>

7) When inspecting the valve clearances for #2, #4 and #6

- (1) Remove the battery and battery carrier. <Ref. to SC(H6DO)-18, REMOVAL, Battery.>
- (2) Remove two fixing clips on the fuel pipe protector (LH).

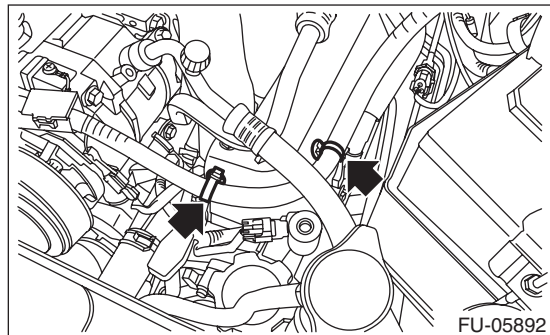

- (3) Generator connector
- (4) Generator terminal B
- (5) Remove the harness cover from collector cover bracket.
- (6) Magnet clutch connector

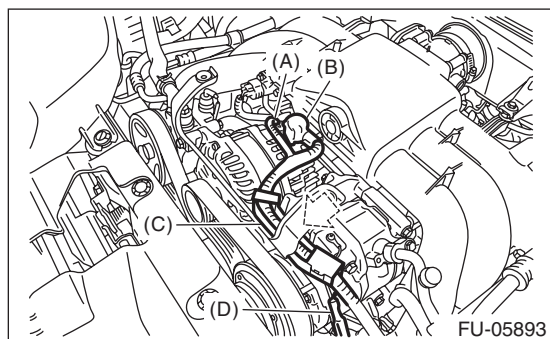

- (A) Generator connector
- (B) Terminal B
- (C) Remove the harness cover from collector cover bracket.
- (D) Magnet clutch connector

(7) Slide the harness and connector to the battery side.

(8) Disconnect the PCV hose from rocker cover (LH).

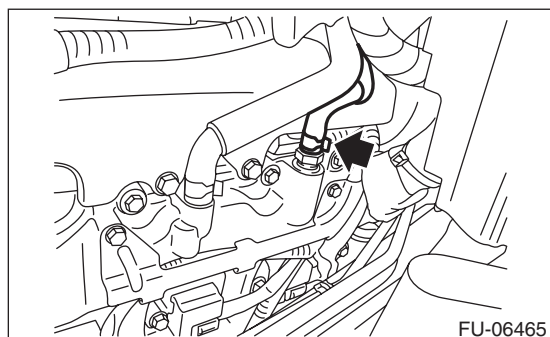

(9) Remove the fuel pipe protector (LH).

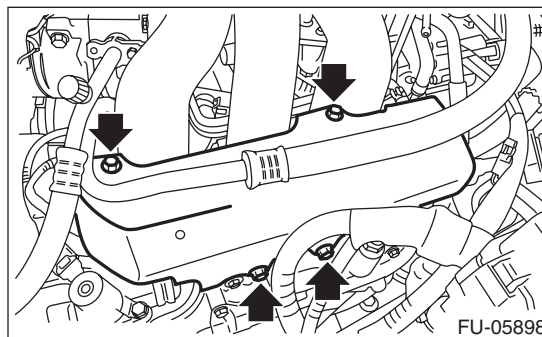

(10) Remove the ignition coil. <Ref. to IG(H6DO)-7, REMOVAL, Ignition Coil.>

(11) Remove the rocker cover (LH). <Ref. to ME(H6DO)-76, REMOVAL, Camshaft.>

8) Turn the crankshaft clockwise until the camshaft is set to position shown in the figure.

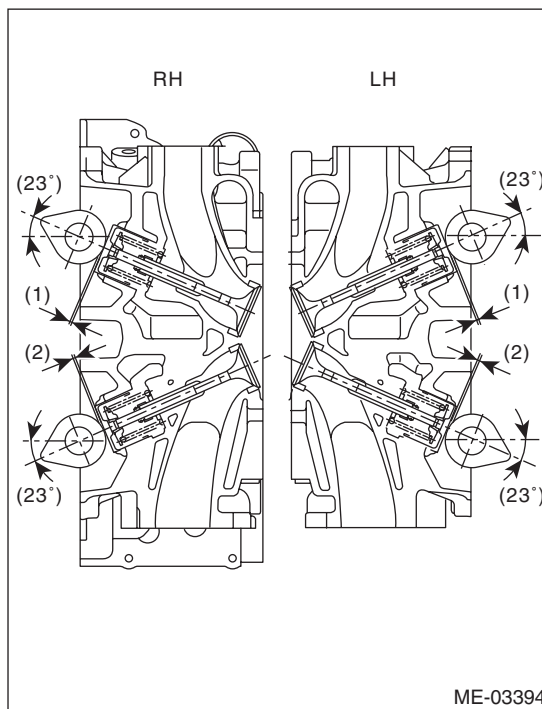

- (1) Valve clearance (intake side)
- (2) Valve clearance (exhaust side)

Valve Clearance

MECHANICAL

9) Measure the clearance of intake valve and exhaust valve using thickness gauge (A).

NOTE:

- Measure it within the range of $\pm 30^\circ$ from specified position shown in the figure.
- Insert a thickness gauge in a direction as horizontal as possible with respect to the valve lifter.
- If the measured value is not within specification, take notes of the value in order to adjust the valve clearance later on.

Valve clearance (inspection value):

Intake

$0.20^{+0.04}_{-0.06}$ mm ($0.0079^{+0.0016}_{-0.0024}$ in)

Exhaust

0.35 ± 0.05 mm (0.0138 ± 0.0020 in)

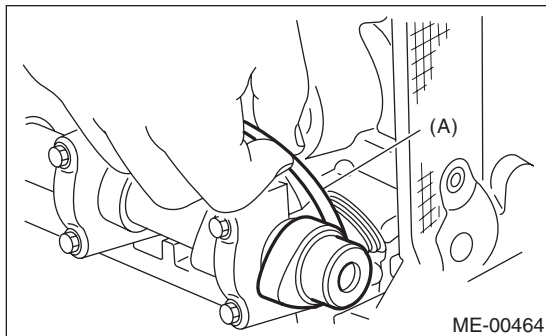

10) If necessary, adjust the valve clearance. <Ref. to ME(H6DO)-34, ADJUSTMENT, Valve Clearance.>

11) Further turn the crank pulley clockwise and then measure the valve clearances again.

12) After inspection, install the related parts in the reverse order of removal. <Ref. to ME(H6DO)-78, INSTALLATION, Camshaft.>

B: ADJUSTMENT

1. INTAKE SIDE

1) Remove the engine from vehicle. <Ref. to ME(H6DO)-36, REMOVAL, Engine Assembly.>

2) Measure all the valve clearances. <Ref. to ME(H6DO)-32, INSPECTION, Valve Clearance.>

NOTE:

Record each valve clearance after measurement.

3) Remove the timing chain assembly. <Ref. to ME(H6DO)-55, REMOVAL, Timing Chain Assembly.>

4) Remove the cam sprocket. <Ref. to ME(H6DO)-74, REMOVAL, Cam Sprocket.>

5) Remove the camshaft. <Ref. to ME(H6DO)-76, REMOVAL, Camshaft.>

6) Remove the valve lifter.

7) Measure the thickness of valve lifter using micrometer.

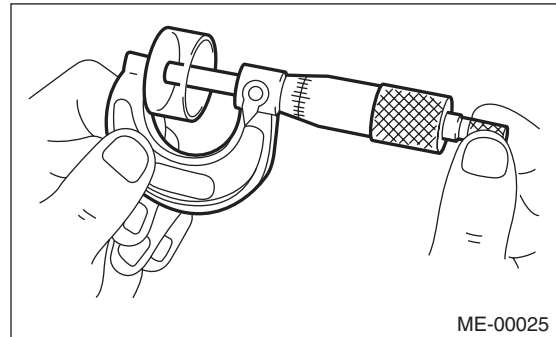

8) Select a valve lifter of suitable thickness using the measured valve clearance and valve lifter thickness, and install it.

NOTE:

Use a new valve lifter.

Unit: mm (in)
$S = (V + T) - 0.20$ (0.0079)
S: Valve lifter thickness required
V: Measured valve clearance
T: Current valve lifter thickness

9) Install the camshaft. <Ref. to ME(H6DO)-78, INSTALLATION, Camshaft.>

10) Install the cam sprocket. <Ref. to ME(H6DO)-74, INSTALLATION, Cam Sprocket.>

11) Install the timing chain assembly. <Ref. to ME(H6DO)-61, INSTALLATION, Timing Chain Assembly.>

12) Measure all valve clearance again at this time. If the valve clearance is not within the adjustment value, repeat the procedure from step 3).

Valve clearance (adjustment value):

$0.20^{+0.04}_{-0.06}$ mm ($0.0079^{+0.0016}_{-0.0024}$ in)

13) After adjustment, install the related parts in the reverse order of removal.

NOTE:

Refer to "Camshaft" when installing the rocker cover. <Ref. to ME(H6DO)-78, INSTALLATION, Camshaft.>

2. EXHAUST SIDE

- 1) Remove the engine from vehicle. <Ref. to ME(H6DO)-36, REMOVAL, Engine Assembly.>
- 2) Measure all the valve clearances. <Ref. to ME(H6DO)-32, INSPECTION, Valve Clearance.>

NOTE:

- Record each valve clearance after measurement.
- 3) Remove the camshaft. <Ref. to ME(H6DO)-76, REMOVAL, Camshaft.>
 - 4) Remove the valve lifter.
 - 5) Measure the thickness of valve lifter using micrometer.

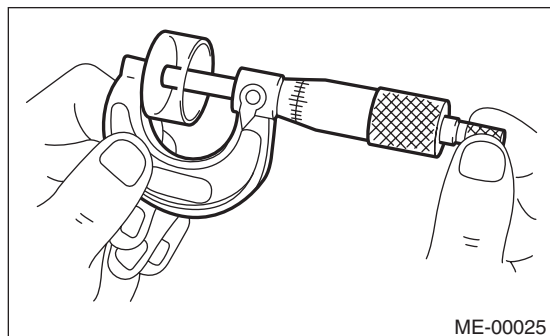

- 6) Select a valve lifter of suitable thickness using the measured valve clearance and valve lifter thickness, and install it.

NOTE:

Use a new valve lifter.

Unit: mm (in)
$S = (V + T) - 0.35$ (0.0138)
S: Valve lifter thickness required V: Measured valve clearance T: Current valve lifter thickness

- 7) Install the camshaft. <Ref. to ME(H6DO)-78, INSTALLATION, Camshaft.>
- 8) Install the cam sprocket. <Ref. to ME(H6DO)-74, INSTALLATION, Cam Sprocket.>
- 9) Install the timing chain assembly. <Ref. to ME(H6DO)-61, INSTALLATION, Timing Chain Assembly.>
- 10) Measure all valve clearance again at this time. If the valve clearance is not within the adjustment value, repeat the procedure from step 3).

Valve clearance (adjustment value):

0.35 ± 0.05 mm (0.0138 ± 0.0020 in)

- 11) After adjustment, install the related parts in the reverse order of removal.

NOTE:

Refer to “Camshaft” when installing the rocker cover. <Ref. to ME(H6DO)-78, INSTALLATION, Camshaft.>