

# Accelerator Pedal

## SPEED CONTROL SYSTEMS

### 2. Accelerator Pedal

#### A: REMOVAL

- 1) Disconnect the ground cable from battery.
- 2) Disconnect the connector.
- 3) Remove the nut securing accelerator pedal assembly, and remove the accelerator pedal assembly.

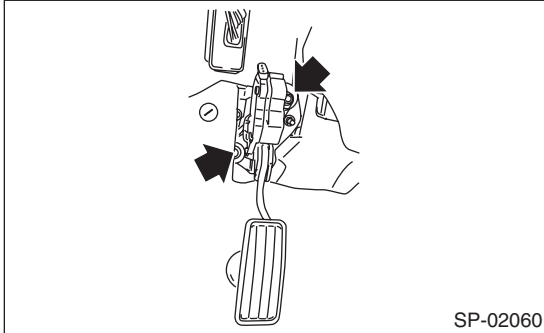

#### B: INSTALLATION

Install in the reverse order of removal.

#### Tightening torque:

**18 N·m (1.8 kgf·m, 13.3 ft·lb)**

#### C: DISASSEMBLY

NOTE:

The accelerator pedal cannot be disassembled.

#### D: INSPECTION

##### 1. CHECK ACCELERATOR PEDAL SENSOR AREA (METHOD WITH CIRCUIT TESTER)

- 1) Remove the front pillar lower trim and console side panel lower RH of passenger's side.
- 2) Detach the floor mat of passenger's seat.
- 3) Remove the protect cover.

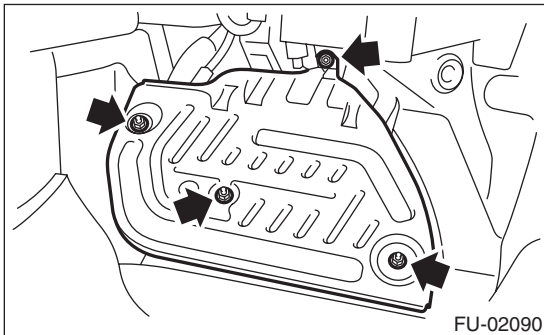

- 4) Remove the ECM from vehicle.

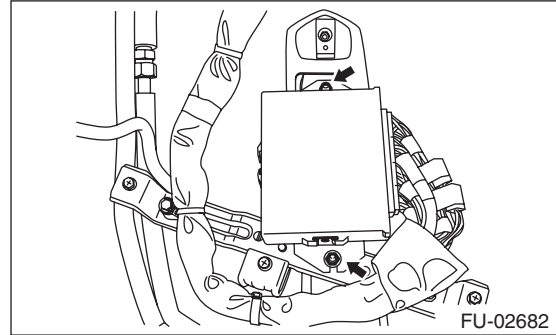

- 5) Turn the ignition switch to ON. (engine OFF)
- 6) Measure the voltage between ECM connector terminals.

Main sensor side

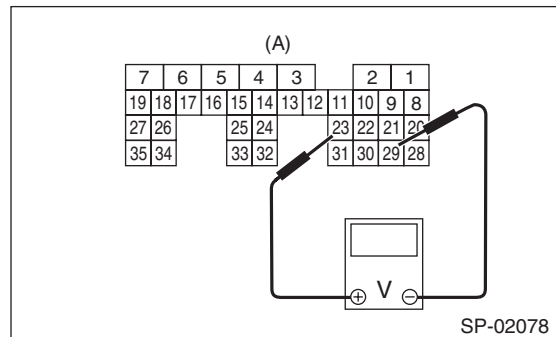

Sub sensor side

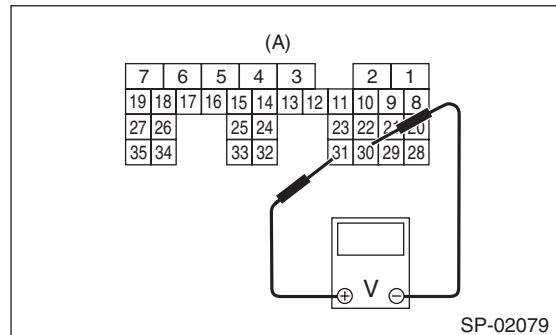

(A) To ECM connector

Accelerator pedal sensor	Accelerator pedal	Terminal No.	Standard
Main	Not depressed (Full closed)	23 (+) and 29 (-)	0.4 — 1.0 V
	Depressed (Full opened)		2.4 — 3.7 V
Sub	Not depressed (Full closed)	31 (+) and 30 (-)	0.3 — 1.1 V
	Depressed (Full opened)		2.3 — 3.8 V

- 7) After inspection, install the related parts in the reverse order of removal.

#### Tightening torque:

**7.5 N·m (0.8 kgf·m, 5.5 ft·lb)**

## 2. CHECK ACCELERATOR PEDAL SENSOR AREA (METHOD WITH SUBARU SELECT MONITOR)

- 1) Turn the ignition switch to ON. (engine OFF)
- 2) Read the accelerator pedal opening angle signal and voltage of accelerator pedal sensor using Subaru Select Monitor. <Ref. to EN(H6DO)(diag)-38, READ CURRENT DATA FOR ENGINE (NORMAL MODE), OPERATION, Subaru Select Monitor.>

Accelerator pedal sensor	Accelerator pedal opening angle signal	Standard
Main	0.0%	0.4 — 1.0 V
	100.0%	2.4 — 3.7 V
Sub	0.0%	0.3 — 1.1 V
	100.0%	2.3 — 3.8 V

## 3. OTHER INSPECTIONS

- 1) Check that the accelerator pedal does not have deformation, cracks or damage.
- 2) Check for smooth operation when the accelerator pedal is depressed.
- 3) Check if the accelerator pedal returns to its original position smoothly when the pedal is released.

# Accelerator Pedal

SPEED CONTROL SYSTEMS

---

# IGNITION

# *IG(H6DO)*

---

	<b>Page</b>
1. General Description .....	2
2. Spark Plug .....	4
3. Ignition Coil .....	7